



**E**UROPEAN  
**T**ELECOMMUNICATION  
**S**TANDARD

**ETS 300 604**

May 1997

Sixth Edition

---

Source: ETSI TC-SMG

Reference: RE/SMG-040907PR5

ICS: 33.020

**Key words:** Digital cellular telecommunications system, Global System for Mobile communications (GSM)



**Digital cellular telecommunications system (Phase 2);  
General requirements on interworking between the Public Land  
Mobile Network (PLMN) and the Integrated Services Digital  
Network (ISDN) or Public Switched Telephone Network (PSTN)  
(GSM 09.07)**

**ETSI**

European Telecommunications Standards Institute

**ETSI Secretariat**

**Postal address:** F-06921 Sophia Antipolis CEDEX - FRANCE

**Office address:** 650 Route des Lucioles - Sophia Antipolis - Valbonne - FRANCE

**X.400:** c=fr, a=atlas, p=etsi, s=secretariat - **Internet:** secretariat@etsi.fr

Tel.: +33 4 92 94 42 00 - Fax: +33 4 93 65 47 16

---

**Copyright Notification:** No part may be reproduced except as authorized by written permission. The copyright and the foregoing restriction extend to reproduction in all media.

© European Telecommunications Standards Institute 1997. All rights reserved.



## Contents

Foreword .....		7
1	Scope .....	9
2	Normative references .....	9
3	Definitions and abbreviations .....	12
4	Introduction.....	13
5	Not used .....	14
6	Network Characteristics .....	14
6.1	Key Characteristics of Networks Concerned .....	14
6.1.1	Characteristics of PLMNs.....	14
6.1.2	Characteristics of PSTNs .....	14
6.1.3	Characteristics of ISDN .....	15
7	Interworking classifications .....	15
7.1	Service interworking.....	15
7.2	Network interworking .....	15
7.3	Signalling interworking .....	18
7.4	Numbering .....	18
7.5	Supplementary service interworking .....	18
8	Compatibility and subscription checking .....	18
9	Interworking to PSTN .....	18
9.1	Speech Calls.....	18
9.1.1	Interworking indications to PLMN terminal .....	18
9.1.2	Transmission aspects .....	18
9.1.3	Generation of In-band Tones and Announcements (PLMN-PSTN).....	18
9.2	Data Calls .....	19
9.2.1	Network interworking mobile originated .....	19
9.2.1.1	Selection of interworking function .....	19
9.2.1.2	Modem Selection.....	19
9.2.1.3	DTE/Modem interface (Filtering) .....	20
9.2.1.4	Mapping of BC-IE from GSM 04.08 to ISUP (or other).....	21
9.2.2	Network Interworking Mobile terminated PSTN Originated.....	21
9.2.3	Transparent service support .....	25
9.2.3.1	Not used .....	25
9.2.3.2	Rate adaptation process in MSC/IWF .....	25
9.2.3.3	Mapping of signalling MS/MSC/IWF to modem interface requirements.....	25
9.2.3.4	Establishment of end-to-end terminal synchronizations .....	26
9.2.3.5	Network Independent Clocking (NIC) .....	27
9.2.4	Non-transparent service support.....	27
9.2.4.1	MSC-IWF Rate adaptation scheme.....	27
9.2.4.2	Protocol layer structure in the MSC/IWF .....	27
9.2.4.3	Re-constitution of user data.....	27
9.2.4.4	Layer 2 relay functionality .....	28
9.2.4.5	In band signalling mapping flow control.....	28
9.2.4.5.1	Conditions requiring flow control towards the fixed network .....	28
9.2.4.5.2	Conditions requiring flow control towards the MS .....	29

	9.2.4.6	Data buffers .....	29
	9.2.4.6.1	Transmit buffers (towards MS).....	29
	9.2.4.6.2	Receive buffers (from MS) .....	29
	9.2.4.7	Transportation of the Break condition .....	29
	9.2.4.8	In band signalling mapping modem status information.....	29
	9.2.4.9	Support of out-band flow control .....	30
	9.2.4.10	Establishment of end-to-end terminal synchronizations .....	30
9.3	Interworking Alternate Speech / Data Calls.....		31
9.3.1	Alternate Speech/Data Interworking .....		31
	9.3.1.1	General .....	31
	9.3.1.2	Mobile originated PSTN terminated calls.....	31
	9.3.1.3	PSTN originated mobile terminated calls.....	31
9.3.2	Speech followed by data interworking .....		32
	9.3.2.1	General .....	32
10	Interworking to the ISDN.....		32
10.1	Speech Calls .....		32
10.2	Data Calls.....		32
	10.2.1	Network interworking mobile originated.....	33
	10.2.1.1	Circuit switched calls.....	33
	10.2.1.2	Packet calls.....	33
	10.2.2	Network interworking mobile terminated .....	33
	10.2.2.1	Circuit switched calls.....	48
	10.2.2.2	Packet calls.....	48
	10.2.3	Transparent service support (see GSM 03.10) .....	48
	10.2.3.1	MSC - IWF rate adaptation scheme .....	48
	10.2.3.2	Rate adaptation process in MSC/IWF .....	48
	10.2.3.3	Mapping of signalling MS/MSC/IWF to modem interface requirements .....	48
	10.2.3.4	Establishment of end-to-end terminal synchronizations .....	49
	10.2.3.5	Network independent Clocking (NIC).....	50
	10.2.4	Non-transparent service support (see GSM 03.10).....	50
	10.2.4.1	MSC - IWF Rate adaptation scheme .....	50
	10.2.4.2	Protocol layer structure in the MSC/IWF.....	50
	10.2.4.3	Re-constitution of user data .....	50
	10.2.4.4	Layer 2 relay functionality.....	50
	10.2.4.5	In band signalling mapping flow control .....	51
	10.2.4.5.1	Conditions requiring flow control - if flow control is provided - towards the fixed network.....	51
	10.2.4.5.2	Conditions requiring flow control towards the MS .....	51
	10.2.4.6	Data buffers .....	52
	10.2.4.6.1	Transmit buffers (towards MS).....	52
	10.2.4.6.2	Receive buffers (from MS) .....	52
	10.2.4.7	BREAK Indication.....	52
	10.2.4.8	Signalling mapping modem status information or in band rate adapted frame information.....	52
	10.2.4.9	Support of out-band flow control .....	52
	10.2.4.10	Synchronizations.....	52
	10.2.4.10.1	V110 Frame synchronizations.....	52
	10.2.4.10.2	RLP Frame start indication.....	52
	10.2.4.10.3	L2R Frame synchronizations.....	52
	10.2.4.10.4	Establishment of end-to-end terminal synchronizations.....	53
	10.2.5	DTE/Modem interface (Filtering) .....	53
10.3	Interworking Alternate speech data calls .....		54
10.3.1	Alternate speech data bearer interworking .....		55
	10.3.1.1	General .....	55
	10.3.1.2	Mobile originated ISDN terminated .....	55
	10.3.1.3	ISDN originated mobile terminated .....	55
10.3.2	Speech followed by data interworking .....		56
	10.3.2.1	General .....	56

- 11 V.110 Frame Synchronization ..... 56
  - 11.1 Initial V.110 frame synchronization ..... 56
  - 11.2 Action on loss of V.110 frame synchronization for non transparent services ..... 56
  - 11.3 Action on loss of V.110 frame synchronization for transparent services ..... 56
  
- Annex A (informative): SDLs..... 58
  
- History..... 60

Blank page

## Foreword

This European Telecommunication Standard (ETS) has been produced by the Special Mobile Group (SMG) Technical Committee of the European Telecommunications Standards Institute (ETSI).

This ETS identifies the Mobile-services Switching Centre (MSC) Interworking Functions (IWFs) and requirements to support interworking between:

- a) Public Land Mobile Network (PLMN) and Public Switched Telephone Network (PSTN);
- b) PLMN and Integrated Services Digital Network (ISDN).

This ETS corresponds to GSM technical specification GSM 09.07 version 4.12.1

The specification from which this ETS has been derived was originally based on CEPT documentation, hence the presentation of this ETS may not be entirely in accordance with the ETSI/PNE Rules.

Reference is made within this ETS to GSM-TSs (note).

Reference is also made within this ETS to GSM xx.xx. series. The specifications in the series can be identified, with their full title, within the normative reference clause of this ETS by the first two digits of their GSM reference number e.g. GSM 09.xx series, refers to GSM 09.01, GSM 09.02, etc.

<b>Transposition dates</b>	
Date of adoption:	4 April 1997
Date of latest announcement of this ETS (doa):	31 August 1997
Date of latest publication of new National Standard or endorsement of this ETS (dop/e):	28 February 1998
Date of withdrawal of any conflicting National Standard (dow):	28 February 1998

Blank page



## 1 Scope

The purpose of this European Telecommunication Standard (ETS) is to identify the Mobile-services Switching Centre (MSC)/Interworking Functions (IWFs) and requirements to support interworking between:

- i) PLMN and PSTN;
- ii) PLMN and ISDN.

It is not possible to treat ISDN and PSTN as one type of network, even when both ISDN and PSTN subscribers are served by the same exchange because of the limitations of the PSTN subscribers access i.e. analogue connection without D-channel signalling.

Within this ETS, the requirements for voice and non-voice (data) calls are considered separately.

## 2 Normative references

This ETS incorporates by dated and undated reference, provisions from other publications. These normative references are cited at the appropriate places in the text and the publications are listed hereafter. For dated references, subsequent amendments to or revisions of any of these publications apply to this ETS only when incorporated in it by amendment or revision. For undated references, the latest edition of the publication referred to applies.

- [1] CCITT Recommendation G.711: "Pulse code modulation (PCM) of voice frequencies".
- [2] CCITT Recommendation I.460: "Multiplexing, rate adaption and support of existing interfaces".
- [3] CCITT Recommendation V.25: "Automatic answering equipment and/or parallel automatic calling equipment on the general switched telephone network including procedures for disabling of echo control devices for both manually and automatically established calls".
- [4] CCITT Recommendation V.110: "Support of data terminal equipments (DTEs) with V-series interfaces by an integrated services digital network".
- [5] ETS 300 102-1 Edition 1: "Integrated Services Digital Network (ISDN); User-network interface layer 3 Specifications for basic call control".
- [6] ETS 300 121: "Integrated Services Digital Network (ISDN); Application of the ISDN User Part (ISUP) of CCITT Signalling System No.7 for international ISDN interconnections (ISUP version 1)".
- [7] GSM 01.04 (ETR 100): "Digital cellular telecommunications system (Phase 2); Abbreviations and acronyms".
- [8] GSM 02.01 (ETS 300 500): "Digital cellular telecommunications system (Phase 2); Principles of telecommunications services supported by a GSM Public Land Mobile Network (PLMN)".
- [9] GSM 02.02 (ETS 300 501): "Digital cellular telecommunications system (Phase 2); Bearer Services (BS) supported by a GSM Public Land Mobile Network (PLMN)".
- [10] GSM 02.03 (ETS 300 502): "Digital cellular telecommunications system (Phase 2); Teleservices supported by a GSM Public Land Mobile Network (PLMN)".
- [11] GSM 02.04 (ETS 300 503): "Digital cellular telecommunications system (Phase 2); General on supplementary services".

- [12] GSM 02.81 (ETS 300 514): "Digital cellular telecommunications system (Phase 2); Line identification supplementary services - Stage 1".
- [13] GSM 02.82 (ETS 300 515): "Digital cellular telecommunications system (Phase 2); Call Forwarding (CF) supplementary services - Stage 1".
- [14] GSM 02.83 (ETS 300 516): "Digital cellular telecommunications system (Phase 2); Call Waiting (CW) and Call Hold (HOLD) supplementary services - Stage 1".
- [15] GSM 02.84 (ETS 300 517): "Digital cellular telecommunications system (Phase 2); MultiParty (MPTY) supplementary services - Stage 1".
- [16] GSM 02.85 (ETS 300 518): "Digital cellular telecommunications system (Phase 2); Closed User Group (CUG) supplementary services - Stage 1".
- [17] GSM 02.86 (ETS 300 519): "Digital cellular telecommunications system (Phase 2); Advice of charge (AoC) supplementary services - Stage 1".
- [18] GSM 02.88 (ETS 300 520): "Digital cellular telecommunications system (Phase 2); Call Barring (CB) supplementary services - Stage 1".
- [19] GSM 03.03 (ETS 300 523): "Digital cellular telecommunications system (Phase 2); Numbering, addressing and identification".
- [20] GSM 03.08 (ETS 300 526): "Digital cellular telecommunications system (Phase 2); Organization of subscriber data".
- [21] GSM 03.11 (ETS 300 529): "Digital cellular telecommunications system (Phase 2); Technical realization of supplementary services".
- [22] GSM 03.45 (ETS 300 538): "Digital cellular telecommunications system (Phase 2); Technical realization of facsimile group 3 transparent".
- [23] GSM 03.46 (ETS 300 539): "Digital cellular telecommunications system (Phase 2); Technical realization of facsimile group 3 non-transparent".
- [24] GSM 03.50 (ETS 300 540): "Digital cellular telecommunications system (Phase 2); Transmission planning aspects of the speech service in the GSM Public Land Mobile Network (PLMN) system".
- [25] GSM 04.08 (ETS 300 557): "Digital cellular telecommunications system (Phase 2); Mobile radio interface layer 3 specification".
- [26] GSM 04.21 (ETS 300 562): "Digital cellular telecommunications system (Phase 2); Rate adaption on the Mobile Station - Base Station System (MS - BSS) Interface".
- [27] GSM 04.22 (ETS 300 563): "Digital cellular telecommunications system (Phase 2); Radio Link Protocol (RLP) for data and telematic services on the Mobile Station - Base Station System (MS - BSS) interface and the Base Station System - Mobile-services Switching Centre (BSS - MSC) Interface".
- [28] GSM 07.01 (ETS 300 582): "Digital cellular telecommunications system (Phase 2); General on Terminal Adaptation Functions (TAF) for Mobile Stations (MS)".
- [29] GSM 07.02 (ETS 300 583): "Digital cellular telecommunications system (Phase 2); Terminal Adaptation Functions (TAF) for services using asynchronous bearer capabilities".

- [30] GSM 07.03 (ETS 300 584): "Digital cellular telecommunications system (Phase 2); Terminal Adaptation Functions (TAF) for services using synchronous bearer capabilities".
- [31] GSM 07.05 (ETS 300 585): "Digital cellular telecommunications system (Phase 2); Use of Data Terminal Equipment - Data Circuit terminating Equipment (DTE - DCE) interface for Short Message Service (SMS) and Cell Broadcast Service (CBS)".
- [32] GSM 08.20 (ETS 300 591): "Digital cellular telecommunications system (Phase 2); Rate adaption on the Base Station System - Mobile-services Switching Centre (BSS - MSC) interface".
- [33] GSM 08.60 (ETS 300 597): "Digital cellular telecommunications system (Phase 2); Inband control of remote transcoders and rate adaptors for full rate traffic channels".
- [34] GSM 09.02 (ETS 300 599): "Digital cellular telecommunications system (Phase 2); Mobile Application Part (MAP) specification".
- [35] GSM 09.03 (ETS 300 600): "Digital cellular telecommunications system (Phase 2); Signalling requirements on interworking between the Integrated Services Digital Network (ISDN) or Public Switched Telephone Network (PSTN) and the Public Land Mobile Network (PLMN)".
- [36] GSM 09.05 (ETS 300 602): "Digital cellular telecommunications system (Phase 2); Interworking between the Public Land Mobile Network (PLMN) and the Packet Switched Public Data Network (PSPDN) for Packet Assembly/Disassembly facility (PAD) access".
- [37] GSM 09.06 (ETS 300 603): "Digital cellular telecommunications system (Phase 2); Interworking between a Public Land Mobile Network (PLMN) and a Packet Switched Public Data Network/Integrated Services Digital Network (PSPDN/ISDN) for the support of packet switched data transmission services".

NOTE: As regards ETS 300 102-1 [5], the edition 1 of this ETS from 1990 shall be used, with one exception: the encoding of the field modem type in the ISDN BC-IE shall be handled as specified in table 6A and 6B of GSM 09.07.

### 3 Definitions and abbreviations

Use is made of the following terms within this ETS. These terms refer to information requirements necessary to support interworking functions, some of these terms will be identifiable with their use in other GSM specifications.

For the purposes of this ETS, the following definitions apply:

**bearer capability information:** Specific information defining the lower layer characteristics required within the network.

**low layer compatibility information:** Information defining the lower layer characteristics of the terminal.

**high layer compatibility information:** Information defining the higher layer characteristics of the terminal.

**compatibility information:** This term subsumes the entirety of Bearer Capability, Low Layer Compatibility, High Layer Compatibility, Progress Indicator and Address Information conveyed out-of-band prior to call establishment for the support of compatibility checking and terminal/function/service selection at the ISDN-type user-network interface.

**protocol identifier:** Information defining the specific protocols utilized for the support of data transfer by a terminal.

**progress indicator:** Information supplied to indicate to the terminal that network interworking has taken place.

**out-of-band parameter exchange:** Information exchanged via an associated or non-associated signalling link e.g. SS No 7.

**PSTN:** Subscriber to network interface supports only analogue terminals.

**ISDN:** Subscriber to network interface supports digital or analogue terminals, plus a standardized user to network associated signalling system and a standardized internetwork signalling system.

**autobauding type 1:** This information element value may be contained in the setup or call confirm messages from the mobile station in association with a non transparent data service. This implies that the MSC/IWF may select any speed and modem type according to what it can negotiate with the remote modem on the PSTN/ISDN. The maximum speed to be used by the MSC/IWF is the user speed indicated in the setup/call confirm message.

**multi self selecting speed modem:** This term applies to V series modems capable of handling one or more lower speeds as a fall back position. When such a modem is requested in the call setup or call confirm message from the MS in association with a non transparent service, the MSC/IWF may select any of the speeds supported according to the negotiation with the remote modem on the PSTN/ISDN. In this instance the maximum starting negotiation speed to be used by the MSC/IWF is the one indicated by the user speed in the setup/call confirm message.

In addition to those below abbreviations used in this ETS are listed in GSM 01.04.

ADPCM	Adaptive Differential Pulse Coded Modulation
DP	Dial Pulse
ITC	Information Transfer Capability
LE	Local Exchange
NT	Network Termination
PABX	Private Automatic Branch Exchange
SPC	Stored Program Control
SS No.7	Signalling System No.7
TE	Terminal Equipment
TA	Terminal Adaptor
TUP	Telephone User Part (of Signalling System No.7)
DSS1	Digital Subscriber Signalling 1
UNI	User Network Interface

## 4 Introduction

General Network Interworking Scenarios are described in GSM 09.01. Since the numbering plan for the ISDN era (E.164) includes the numbering plan for the telephone network (E.163), it is not possible to distinguish by the number whether a given subscriber is a PSTN or ISDN subscriber. Further, in some countries both PSTN and ISDN subscribers will be connected to the same exchange, so the only difference for this type of combined network will be in the nature of the customer access. In this document a PSTN is considered to support only an analogue interface towards the subscriber. An ISDN shall be considered to support digital interface towards the subscriber. In addition, the ISDN is considered to support a standardized outband signalling protocol both between the subscriber and the network and within the network, i.e. DSS1 and ISUP, thus enabling the generation and transport of Compatibility Information for compatibility checking and terminal/function/service selection at the user-network interface as well as for MSC/IWF selection.

There now exist networks which do not fall into either of these categories in that they provide for digital connectivity from subscriber to subscriber through the network. The subscribers have access to a wide range of services by a limited set of standard multi-purpose user network interfaces. However, these networks do not support the standardized inter-exchange signalling protocol throughout, in that they are e.g. using TUP or National User Part (NUP). These types of network support 64 kbit/s connections, so in service support are comparable to ISDN, however, the signalling system provided may not support transport of all Compatibility Information allowed for in the standardized ISDN signalling. This document will therefore identify interworking to PSTN and ISDN on the principle of the network characteristics as identified in the previous paragraph. The aforementioned existing networks then constitute one particular case in the ISDN interworking scenarios. These cases will be itemized when the implication of the various degrees of exhaustiveness of the Compatibility Information - delivered via the ISDN - used for deducting a GSM Basic Service needs to be set forth.

When two dissimilar networks are required to interwork in order to support a communication between two subscribers, one on each network, a number of Interworking Functions (MSC/IWFs) are required to support the communication. Some of these are related to the differences in signalling and are dealt with in GSM 09.03.

Examples of other aspects of interworking are:

- i) the need or otherwise of echo control devices;
- ii) the need or otherwise of modem pools and network-based rate adaptation.

For the purposes of determining the required MSC/IWFs, it is necessary, however, to consider separately each type of interworking (i.e. PLMN-ISDN and PLMN-PSTN) since, in the worst case, "PSTN" could refer to an essentially analogue network with electromechanical switching not controlled by software and without common-channel signalling.

Some facilities associated with alternate speech and data may not be available with version 1 of the MAP. Version 1 of the Mobile Application Part (MAP) does not support transfer between the HLR and VLR, and VLR and VMSC of multiple bearer capabilities. In addition, version 1 of the MAP does not support in-call modification and channel mode modification following an inter-MSC handover.

**5 Not used**

**6 Network Characteristics**

**6.1 Key Characteristics of Networks Concerned**

**Table 1/09.07: Key Characteristics of Networks Concerned**

Characteristic	GSM PLMN	ISDN	PSTN
Subscriber Interface	Digital	Digital	Analogue
User-network signalling	GSM 04.08	DSS1, other UNIs	loop-disconnect and DTMF
User-terminal equipment supported	MT0, MT1 or MT2 functions (see GSM 04.02)	Digital TE (ISDN NT, TE1 or TE2+TA) see e.g. I.411	Analogue TE (e.g. dial pulse telephones PABXs modem equipped DTEs)
Inter-exchange signalling	SS No.7 ISUP TUP+, MAP	SS No.7 ISUP TUP+, TUP, NUP	Channel associated (e.g. R2, No.4, No.5) or common channel (e.g. No.6)
Transmission facilities	Digital	Digital	Analogue
Exchange types	Digital	Digital	Analogue/digital
Information transfer mode	Circuit	Circuit/Packet	Circuit
Information transfer capability	Speech, digital unrestricted, alternate speech/ group 3 fax etc.	Speech, digital unrestricted, 3.1 kHz audio, video etc.	3.1 kHz audio (voice/voice- band data)

**6.1.1 Characteristics of PLMNs**

The GSM PLMN is fully defined in the GSM Technical Specifications.

**6.1.2 Characteristics of PSTNs**

Because of the efforts at an early stage to standardize ISDNs in different countries, the differences between any two ISDNs will be small compared with the differences between PSTNs, which have evolved in different ways in different countries. In some cases the evolution has occurred over many decades, and therefore each PSTN is distinct, and for a recommendation on interworking, it is necessary to make certain assumptions about a generalized PSTN.

Whilst the key characteristics of PSTNs are given in table 1 above, the specific MSC/IWFs needed to allow interworking between a PLMN and a PSTN will depend on the nature of the PSTN concerned.

Table 2/09.07 below gives a number of categories that can be used to classify PSTNs and a number of possibilities within each category.

**Table 2/09.07: Characteristics of PSTNs**

Category	Possibilities within Category
Type of subscriber signalling	a) PSTN with loop disconnect subscriber signalling (10 pps)
	b) PSTN with DTMF subscriber signalling
Type of interexchange signalling	a) PSTN with channel-associated signalling
	b) PSTN with common-channel signalling
Type of interexchange transmission	a) Analogue
	b) Digital
Type of exchange switching	a) PSTN with electro-mechanical switching
	b) PSTN with electronic (non-digital) switching
	c) PSTN with electronic digital switching
Type of exchange control	a) Non-SPC
	b) SPC

NOTE: Under each category, it is possible that a PSTN will have a combination of the possibilities rather than only one.

### 6.1.3 Characteristics of ISDN

For the "standardized ISDN" in principle taken into account here, these are defined in the ETS-series.

## 7 Interworking classifications

### 7.1 Service interworking

Service interworking is required when the Teleservices at the calling and called terminals are different. No service interworking, except for facsimile group 3 (GSM Teleservice 61 or 62 interworking with standard facsimile group 3 service), has been identified as a requirement of the GSM system for PSTN/ISDN network based services.

### 7.2 Network interworking

Network interworking is required whenever a PLMN and a non-PLMN together are involved to provide an end-to-end connection and may be required in instances of PLMN to PLMN connections.

The concept of Bearer Services was developed for the ISDN and has been extended to the PLMN. A bearer service is defined (in GSM 02.01) as:

A type of telecommunication service that provides the capability for the transmission of signals between user-network interfaces.

Bearer services are described by a number of attributes, where an attribute is defined as a specified characteristic of an object or element whose values distinguish that object or element from others.

For the purpose of this TS, a PSTN is assumed to provide a bearer service which equates to an ISDN 3.1 kHz audio bearer service.

Refer to GSM 02.02 for complete list of bearer services. Refer to GSM 04.08 for coding of Bearer Capabilities.

**Table 3/09.07: Bearer Service Interworking**

Bearer service category in GSM PLMN	Bearer Service in GSM	Bearer service in ISDN	Service in PSTN
Circuit mode unstructured with unrestricted digital capability  Transparent and Non transparent	Asynchronous Data 300 bit/s	Cct mode structured 64 kbit/s unrestricted	Not Applicable
	Asynchronous Data 1.2 kbit/s		
	Asynchronous Data 1 200/75 bit/s		
	Asynchronous Data 2.4 kbit/s		
	Asynchronous Data 4.8 kbit/s		
	Asynchronous Data 9.6 kbit/s		
Circuit mode unstructured with unrestricted digital capability Transparent	Synchronous Data 1.2 kbit/s		
	Synchronous Data 2.4 kbit/s		
	Synchronous Data 4.8 kbit/s		
	Synchronous Data 9.6 kbit/s		
Circuit mode unstructured with unrestricted digital capability. Non-transparent	Packet Services see GSM 09.06	Packet Services See GSM 09.06	
3.1 kHz Audio Ex PLMN Transparent and Non-transparent	Asynchronous Data 300 bit/s	Cct Mode  3.1 kHz Audio	Cct Mode  3.1 kHz Audio
	Asynchronous Data 1.2 kbit/s		
	Asynchronous Data 1 200/75 bit/s		
	Asynchronous Data 2.4 kbit/s		
	Asynchronous Data 4.8 kbit/s		
	Asynchronous Data 9,6 kbit/s		
3.1 kHz Audio Ex PLMN  Transparent	Synchronous Data 1.2 kbit/s		
	Synchronous Data 2.4 kbit/s		
	Synchronous Data 4.8 kbit/s		
	Synchronous Data 9.6 kbit/s		
3.1 kHz Audio Ex PLMN Non Transparent	See GSM 09.06	See GSM 09.06	



Table 3/09.07: Bearer Service Interworking (concluded)

Bearer service category in GSM PLMN	Bearer Service in GSM PLMN	Bearer service in ISDN	Service in PSTN
Alternate speech /data circuit mode unstructured with 3.1 kHz audio ex PLMN Transparent	alternate speech/ asynchronous (with user rates 300 to 9 600 bit/s as above)  alternate speech/ synchronous (with user rates 1 200 to 9 600 bit/s as above)		
Alternate speech/data circuit mode unstructured with 3.1 kHz audio ex PLMN non transparent	alternate speech/ asynchronous (with user rates 300 to 9 600 bit/s as above)	Cct mode 3.1 kHz Audio	Cct mode 3.1 kHz Audio
Circuit mode with speech followed by data Transparent and Non transparent	Cct mode speech followed by data 300 to 9 600 bit/s asynchronous as above	Cct mode 3.1 kHz audio	

Table 4/09.07: Network interworking of GSM Teleservices

Teleservice in GSM PLMN	Lower layer capabilities addressed in the GSM Bearer Capabilities IE	Bearer service in ISDN	Service in PSTN
Telephony	Unstructured with speech capability	Speech or Cct mode	Cct Mode
Emergency calls	Unstructured with speech capability	3.1 kHz audio	3.1 kHz audio
Alternate speech/ facsimile group 3	Data Cct duplex synchronous access alternate speech group 3 fax	Cct mode 3.1 kHz audio	Cct mode 3.1 kHz audio
Automatic Facsimile group 3	Data Cct duplex synchronous access group 3 fax	Cct mode 3.1 kHz audio	

This table does not identify any relationship between Teleservices in the GSM PLMN with those in the ISDN/PSTN, it is merely to identify the interworking of the lower network layers of that teleservice with the network layers i.e. bearer service in the ISDN/PSTN.

### 7.3 Signalling interworking

See GSM 09.03.

### 7.4 Numbering

See GSM 03.03.

### 7.5 Supplementary service interworking

For general aspects of supplementary services refer to GSM 03.11, GSM 03.8x and 03.9x series.

Not every supplementary service may be used in combination with each basic service. The applicability of each supplementary service for a basic service is defined in GSM 02.8x and 02.9x-series. Certain application rules are also set out in GSM 02.03, 09.05 and 09.06.

This clause only deals with data service specific aspects of supplementary services, i.e. MSC/IWF functions concerned in combination with supplementary services. This interworking is described in GSM 02.04, GSM 02.8x, and 02.9x-series, GSM 03.11, GSM 03.8x and GSM 03.9x-series, if applicable.

## 8 Compatibility and subscription checking

Compatibility checking is carried out on the following items:

- a) Low layer compatibility - utilizing low layer compatibility and bearer capability information elements.
- b) High layer compatibility - utilizing high layer compatibility information element.

The use of the progress indicator for compatibility checking is outside the scope of this ETS.

Indication of compatibility requirements is carried out as described in subclause 9.2.2 under "a) Functional operation" or "b) Mobile subscriber indicates requirement in call confirmation message" and subclause 10.2.2 "Network interworking mobile terminated".

For subscription checking, relevant for the interworking described in clauses 9 and 10 of this ETS, refer to GSM 02.01.

## 9 Interworking to PSTN

### 9.1 Speech Calls

#### 9.1.1 Interworking indications to PLMN terminal

An indication to inform the PLMN terminal that:

- i) instead of receiving out-of-band indications for certain types of failure conditions, a tone or announcement will be received in-band from the PSTN;
- ii) the available compatibility information will be not exhaustive for deducing a GSM Basic Service and there will be a limitation on address - the terminal may be required to accept the call on the basis of indicating its compatibility requirements;
- iii) (if a DTE) in-band handshaking signals should be anticipated.

#### 9.1.2 Transmission aspects

Includes control of Speech Processing and Echo Control Devices, see GSM 03.50.

#### 9.1.3 Generation of In-band Tones and Announcements (PLMN-PSTN)

In-band tones and announcements shall be provided for all speech and 3.1 kHz audio bearer services between a PLMN and a PSTN.

## 9.2 Data Calls

Low Layer Compatibility Checking on the received GSM bearer capability information element will be carried out by the MSC/IWF to check if the call setup is compatible to the bearer service (3.1 kHz audio) provided by a PSTN and to the IWFs provided by the PLMN.

In case the call setup does not conform to these requirements (e.g. an information transfer capability value "unrestricted digital information" is requested), the call shall fail with an error cause indicating that the network is unable to support the service requested.

As well as compatibility checking subscription checking shall be performed. If the subscription check fails the call setup shall be rejected.

For the case where the MS offers negotiable values in the GSM bearer capability information element (e.g. both transparent and non-transparent connection element) refer to the definitions specified in GSM 07.01.

For interworking of data calls between a PLMN and a PSTN a modem will be utilized to provide the interworking function.

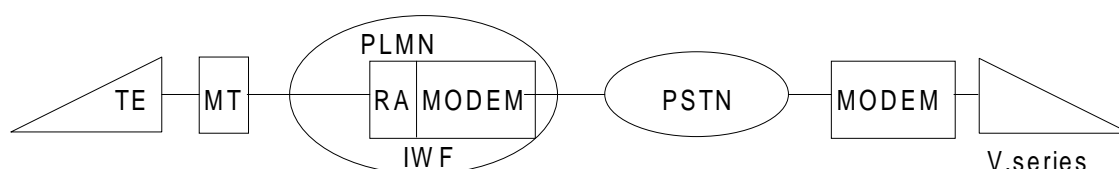

Figure 1: PLMN PSTN interworking for circuit switched calls

### 9.2.1 Network interworking mobile originated

#### 9.2.1.1 Selection of interworking function

The interworking function will need to negotiate with the user to establish the appropriate modem selection e.g. data rate, modulation scheme, etc. In addition, it will also be required to convert the signalling format, from a combination of out of band and in band, to that suitable for controlling the modem and the autodialling line procedure function where applicable. In the following modem selection procedures it is assumed that the interworking function and modems will be associated with each MSC. As an alternative, a centralized modem resource is possible as a network provider option. Signalling between the MSC and the centralized modem resource is outside the scope of this ETS.

For a data call originated by a circuit mode data terminal on the PLMN, the modem selection is done by using the element "modem type" in the call set-up message (bearer capability).

In addition, other elements of the call setup will indicate the user rate, etc. to be used via that modem. The use of this information however means that the network is only able to select a modem from the modem pool which conforms to the speed which the terminal is utilizing at the DTE/DCE interface at the mobile station (e.g. V.22 for 1 200bps). The exception to this is where the user has selected the non transparent service in which case either an autobauding or multi self selecting speed modem (e.g. V.32) may be used.

#### 9.2.1.2 Modem Selection

In general terms the indication of the bearer capability parameter "Information Transfer Capability" will be utilized in the call set-up message to determine when the modem should be selected in the call.

In case of single calls, the modem function shall operate in the calling mode in case of mobile originated calls and in the answering mode in case of mobile terminated calls.

In case of dual data calls (alternate speech/data, speech followed by data) the operation mode of the modem (working in calling or answering mode) depend on the initial call setup direction and on the optional parameter "Reverse Call Setup Direction" information element of the MODIFY message. If this information element is omitted the direction is derived from the initial call setup direction, i.e. the mode is the same as in case of single calls.

For the attribute value "3.1 kHz audio Ex PLMN" and "facsimile group 3", the modem will be selected immediately. The line procedure according to V.25 will then be carried out using the appropriate modem functions.

For the Bearer Service 61 "Alternate speech/data" or the Teleservice 61 "Alternate speech/facsimile group 3", (if speech is selected as the first service) and the Bearer Service 81 "Speech followed by data", the modem is made available but not selected until the subscriber indicates the change of service request (see subclause 9.3).

In case of the Bearer Service 61 "Alternate speech/data" and the Bearer Service 81 "Speech followed by data", instead of the line procedures for the autocalling mode according to CCITT rec. V.25 (i.e. 1 300 Hz tone sending and 2 100 Hz tone recognition for mobile originated single calls) the manual data calling procedure shall apply. For mobile terminated single calls the modem function shall send the 2 100 Hz answering tone.

For "alternate speech/facsimile group 3" calls refer to GSM 03.45 and 03.46.

### 9.2.1.3 DTE/Modem interface (Filtering)

The DTEs taken into account for the PLMN at the MS side conform to CCITT's DTE/Modem interface specifications, which assume basically an error-free environment, i.e.:

- limited distance, point-to-point local interconnection of the interface circuits for data and status;
- steady state signalling.

The envisaged use of these DTEs in the PLMN environment leads to the exposure of these "interconnections" to the PLMN Radio Channel. To assure proper operation even under these conditions appropriate measures have to be taken. In the "non-transparent case" the RLP satisfies the requirement for both data and status lines. In the "transparent" case, the:

- data line aspects have to be dealt with end-to-end between the users; while
- status line aspects are of concern to the network which are dealt with in the following.

The use of the channel control information for the remote control of the DTE/Modem control interchange-circuits between the MS and the MSC/IWF (the conveyance of which is supported by the rate adaptation scheme adopted for PLMN application) requires alignment to the particular transmission occurrences in the traffic channel to be taken into account within the PLMN. In principle this can be best achieved by:

- relying only on the PLMN outband signalling as far as connection control is concerned;
- eliminating the dependence upon the transmission of channel control information via the radio link.

Support for this strategy is given to a certain extent by the confinement of PLMN data connection to:

- full duplex operation;
- switched service (demand access);
- mapping of connection-control relevant conditions of the DTE/DCE control interchange-circuits to/from outband PLMN signalling according to GSM 04.08 after successful traffic channel synchronization (refer to subclause 9.2.3.4);
- flow control by a network entity supported only in non-transparent mode;
- support of connections with the same user data rate only (no TA end-to-end flow control in case of transparent mode).

The only DTE/Modem control interchange-circuit conditions, which actually are not covered by the above confinements, are the indications of readiness for data transmission, i.e. CT106/109 in case of V.-series interface and I-circuit in case of X.-series interface. As the effect of a conditions change of the aforementioned DTE/Modem interchange-circuits depends on the:

- phase within the course of the connection;
- direction of change (ON-OFF or OFF-ON).

The required precaution to be applied (Filtering) must be determined individually in view of:

- function deduced from the change;
- resilience of the connection needed;
- error condition possibly invoked due to a delay in performing the condition change of the control interchange circuit;
- potential loss of performance in connection usage.

The details of the filtering function are laid down in GSM 07-series. Filtering of channel control information is only relevant at the MS side in the transparent mode of operation.

#### **9.2.1.4 Mapping of BC-IE from GSM 04.08 to ISUP (or other)**

As it cannot be determined from the called address whether the distant network is a PSTN or an ISDN the same mapping takes place as for ISDN calls (see table 6a), if ISDN signalling is used between different MSCs (e.g. on the link VMSC - GMSC).

#### **9.2.2 Network Interworking Mobile terminated PSTN Originated**

This clause describes the interworking of calls where the calling subscriber cannot generate or communicate Compatibility Information exhaustive for deducing a GSM Basic Service to a PLMN (gateway MSC/interrogating node) because of lack of ISDN signalling capability. Thus the HLR is relieved from any compatibility checking for such calls.

Two methods of allocating MS International ISDN Numbers (MSISDNs) are allowed: Firstly, a separate MSISDN may be allocated for each service, or service option, which a subscriber uses for incoming calls; or, alternatively, a single number, applicable for all incoming calls is used.

It should be noted that it is possible for both schemes to co-exist within the PLMN and that they are not mutually exclusive.

- a) Multiple MSISDNs are used ("The Multi-numbering Scheme"). See figure 2.

In this scheme, the HPLMN will allocate a number of MSISDNs to a subscriber and associate with each of these numbers some interworking information ("IWI"). According to GSM 03.08 this IWI comprises of either one or two complete GSM Bearer Capability (GSM BC) information element(s) (Contents according to GSM 07.01 and coded as per GSM 04.08). In either case, when the HLR receives an interrogation relating to an incoming call (i.e. the MAP "Send Routing Information" procedure), it requests a roaming number (MSRN) from the VLR. This request will contain the GSM BC(s) reflecting the service associated with the called MSISDN, i.e. the GSM BC(s) are passed to the VLR.

If two GSM BC-IE have to be sent to the VLR they are preceded by a repeat indicator information element according to GSM 04.08. These three information elements shall be included within the MAP parameter "GSM Bearer Capability" of the message "Provide Roaming Number".

At the VMSC, when the incoming call arrives, the GSM BC(s) associated with the MSRN are retrieved from the VLR and sent to the MS at call set-up.

Where the PLMN specific parameters "connection element" and "radio channel" requirements contained in the retrieved GSM BC-IE, indicate dual capabilities then the VMSC shall set them according to its capabilities/preferences. Additionally the parameters correlated to those mentioned above may have to be modified in accordance with GSM 07.01.

The same applies to the parameter modem type if "autobauding type 1" is indicated but the IWF does not support this feature.

Where single capabilities are indicated then the VMSC shall use the requested values if it is able to support the service requested. If it is unable to support the requested service then it shall set them according to its capabilities/preferences.

Where the Compatibility Information is provided in a degree exhaustive to deduce a GSM Basic Service (see application rules in subclause 10.2.2), then the VMSC in providing the GSM BC IE in the setup message shall set the PLMN specific parameters to its capabilities/preferences.

On receipt of a Set-up message containing the compatibility information, the MS will analyse the contents to decide whether the service can be supported (with or without modification, see GSM 07.01) and the call will be accepted or rejected as appropriate.

These negotiable parameters in the GSM BC-IE are: Connection Element (Transparent/non-transparent), Radio Channel Requirements (Half/Full Rate), number of data bits, number of stop bits and parity as well as the correlated parameters Structure, Intermediate Rate, Modem Type and User Information Layer 2 Protocol, see GSM 07.01. This negotiation takes place by means of the MS reflecting back to the MSC a complete bearer capability information element in the call confirm message, with the relevant parameters changed. If this does not take place (i.e. if there is no GSM BC present in the call confirmed message), then the MSC will assume that the values originally transmitted to the MS are accepted.

In addition the MS may propose to the network to modify the user Rate, Modem Type, Intermediate Rate in the CALL CONFIRMED message. The network may accept or release the call.

- b) A Single MSISDNs is used ("The Single-numbering Scheme"). See figure 3.

In the single-numbering scheme, the HPLMN will allocate one MSISDN to a subscriber, applicable to all services.

In this case, when the HLR receives an interrogation relating to an incoming call without compatibility information exhaustive for deducing a GSM Basic Service (i.e. the MAP "Send Routing Information" procedure), the request to the VLR for a roaming number will not contain compatibility information i.e. a GSM BC.

At the VLR, when the incoming call arrives, there is no GSM BC associated with the MSRN and so the call set-up to the mobile will not contain the GSM BC element.

In this case, the MS will return a complete single or dual GSM BC in the Call Confirmed message, indicating the service required by the mobile subscriber. The VMSC will analyse this GSM BC(s) and optionally perform subscription checking (see GSM 02.01). If the requested GSM BC can be supported the call is established, otherwise the call will be released.

Mobile terminated, PSTN originated call compatibility information provided not exhaustive for deducing a GSM Bearer Service; HLR uses multiple MSISDN numbers with corresponding BCs.

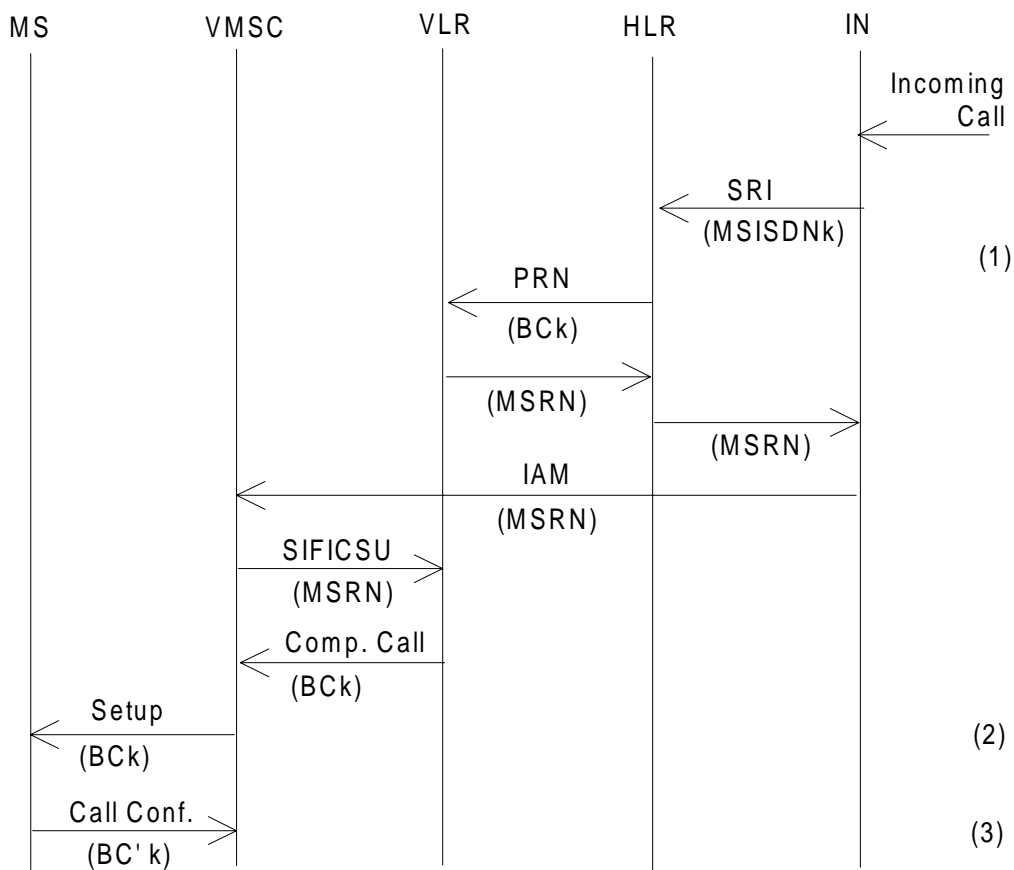

- NOTES:
- (1) The HLR translates the received MSISDN\_ called address (MSISDNk) into the relevant bearer capability information (Bck).
  - (2) The parameters "connection element" and "radio channel requirements" of Bck may be provided/modified according to MSC's capabilities/preferences.
  - (3) In the "Call Confirm" message, the MS may modify some parameters of the BC. See subclause 9.2.2.

Abbr.:

- SRI - Send Routing Information.
- PRN - Provide Roaming Number.
- MSRN - Mobile Station Roaming Number.
- IAM - Initial Address Message.
- SIFICSU - Send Information For Incoming Call Set Up.

Figure 2

Mobile terminated, PSTN originated call Compatibility Information provided not exhaustive for deducing a GSM Bearer Service; HLR uses single MSISDN numbers (no corresponding BC stored). Per call MSRN allocation.

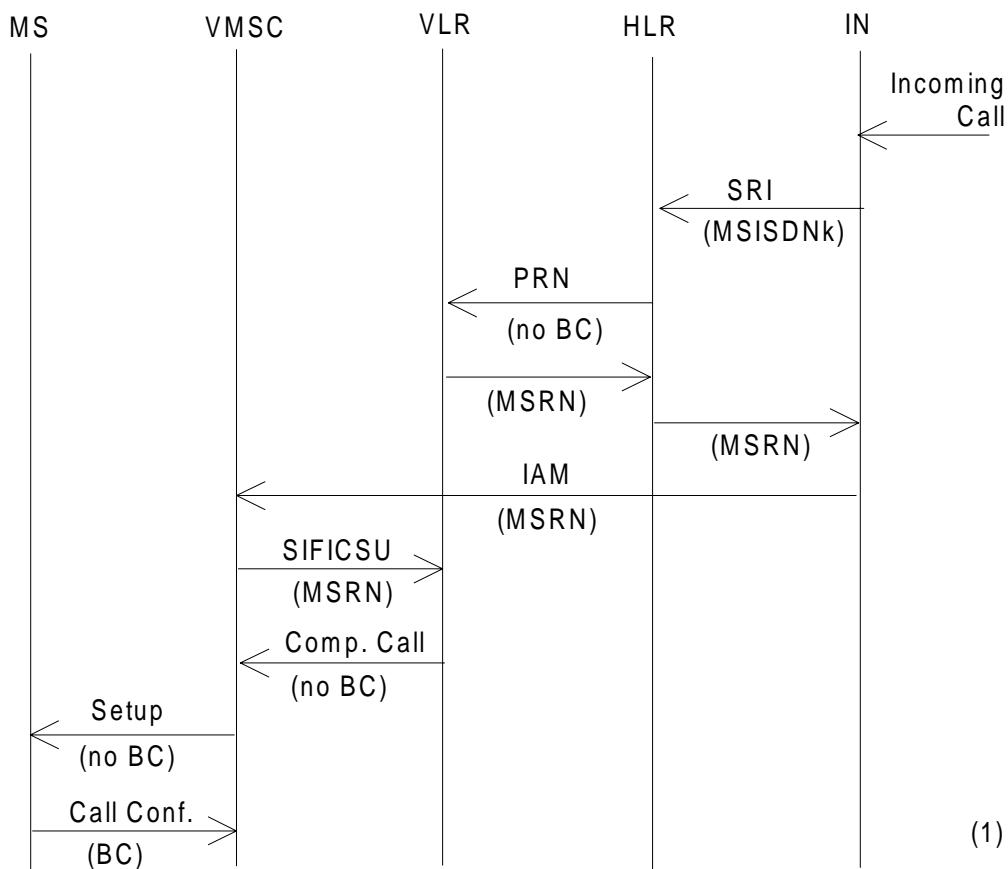

NOTE: (1) This BC is derived from information stored in the Mobile Station, according to its configuration.

Abbreviations: See figure 2.

Figure 3



### 9.2.3 Transparent service support

NOTE: See GSM 03.10.

GSM 08.20 identifies the rate adaptation scheme to be utilized on the BS to MSC link. The transcoding function will generate the 64 kbit/s rate adapted format utilizing the 8 and 16 kbit/s intermediate data rates. The MSC to MSC/IWF link (e.g. in the case of handover) will utilize the same 64 kbit/s rate adaptation scheme as that indicated in GSM 08.20.

For the transparent service support the MSC/IWF will select the modem and speed based on the Compatibility information contained in either the call set-up or call confirmed message reference subclauses 9.2.1 and 9.2.2. Where the modem type indicated is one of the multi-speed versions, e.g. V.32, then the MSC/IWF will restrict the modem to the speed indicated in the call set-up and call confirmed message, respectively, i.e. will inhibit the modem from changing speed, irrespective of the conditions, error rate, encountered on the PSTN link. This scenario is also applicable for the use of "autobauding" modems, in that only the specifically requested modem type and speed will be selected at the MSC/IWF (however Facsimile Gp 3 can use channel mode modify).

#### 9.2.3.1 Not used

#### 9.2.3.2 Rate adaptation process in MSC/IWF

This process is a reverse - related to the CCITT V.110 80 bit frame part - of that provided in the Terminal Adaptation function of the MS. GSM 04.21 refers to the rate adaptation mechanism to be provided.

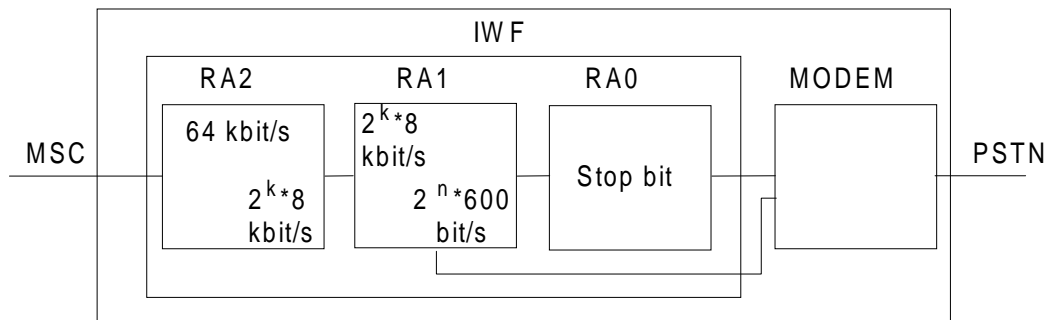

Figure 4: Rate adaptation schematic

In case of asynchronous bearer services and the facsimile teleservices in the transparent mode, the IWF shall disregard the value of bits E4, E5, E6 and E7 in the data transmission phase.

#### 9.2.3.3 Mapping of signalling MS/MSC/IWF to modem interface requirements

This process also is a reverse of the function provided in the Terminal Adaption function of the MS for the mapping of DTE/DCE signalling information to Dm channel and in band signalling information. GSM 07.02 and 07.03 refer.

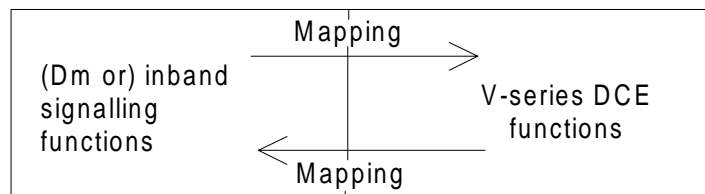

Figure 5: Signalling mapping schematic

In general it is not required for the modem in the MSC/IWF to support a "remote looping" request from a modem in the PSTN. In addition the invocation of a "remote looping" request from the mobile subscriber to a modem in the PSTN need not be supported (see also GSM 07.01). Specific test loops for mobile subscribers to contact may be provided at the network operators discretion.

#### 9.2.3.4 Establishment of end-to-end terminal synchronizations

Prior to exposing the traffic channel of a PLMN connection to transmission of user data, the controlling entities of the connection have to assure of the availability of the traffic channel. This is done by a so called synchronizations process:

- starting on the indication of "physical connection established" resulting from the PLMN-inherent outband signalling procedure. This indication is given on sending the message CONNECT in case of MOC, CONNECT ACKNOWLEDGEMENT in case of MTC and MODIFY COMPLETE (which is sent after reception of the ASSIGN COMPLETE message) in case of in-call modification;
- ending by indicating the successful execution of this process to the controlling entity, which then takes care of the further use of the inband information (data, status).

Network interworking within an MSC/IWF is concerned with the terminating side (to the MS) and the transit side (to the fixed network) of a connection. Both sides have to be treated individually related to the synchronizations process.

With respect to the terminating side the procedure is as follows:

- sending of synchronizations pattern 1/OFF (all data bits "1"/all status bits "OFF") to the MS using the RA1/RA2 rate adaptation function;
- searching for detection of the synchronizations pattern 1/OFF from the MS within valid V.110 frames. This implies that the E1, E2 and E3 bit of the V.110 frame shall be checked for the appropriate user rate in order to distinguish the synchronization pattern from the BSS idle data frame.

With respect to the transit side the procedure is as follows:

- Holding the modem interchange circuits (with the exception of CT108) in the OFF condition until timer T (see below) expires, when they are switched to ON.

When the 1/OFF from the MS has been recognized as a steady state, the MSC/IWF continues sending the synchronizations pattern 1/OFF to the MS unless a timer T (= 500 ms) expires. From this time the information on CT106 and CT109 from the Local Modem are directly mapped to the Sb and X bits toward the MS. The IWF is allowed to map CT 104 to the data bits sent towards the MS and to map data bits received from the MS to CT 103.

##### Mobile Originated

At the start of timer T, i.e. on receipt of the synchronizations pattern from the MS, circuit 108 to the selected modem associated with the connection will be switched from the "OFF" to "ON" condition, thus initiating the auto calling sequence.

##### Mobile Terminated

At the start of timer T, i.e. on receipt of the synchronizations pattern from the MS, circuit 108 to the selected modem associated with the connection will be switched from the "OFF" to "ON" condition, thus initiating the establishment of the modem connection.

It should be noted that in a GSM-PLMN V.-series and X.-series interfaces are only supported in full duplex mode. Thus the call control phase can be mapped almost completely to the signalling procedure (the S-bits during the call control phase are irrelevant). However, the "ready for data" condition (i.e. CT106/109, in case of V.-series interface, and I-circuit, in case of X.-series interface) is mapped directly to the applicable status bits of a V.110 frame towards the MS (see also filtering of channel control information).

### 9.2.3.5 Network Independent Clocking (NIC)

The network independent clocking function is invoked by the VMSC/IWF when the service requested (MO or MT) is 3.1 kHz Ex PLMN and synchronous. The above rule applies irrespective of the information contained in the GSM 04.08 setup message regarding NIC. For all other services NIC is not used.

Within the GSM network the coding of the values for bits associated with NIC is specified in GSM 04.21/08.20. In the forward (transmitting) direction the multiframes shall be coded in exact accordance with that specified in those GSM. Bit E6 is set to "1" in alternate modified V.110 frames at the transmitter. However, the use of this bit at the receiver for monitoring frame Synchronization, or any other purpose, is not specified and is left to the discretion of the implementor.

A "perfect linear block Code" is used in C1-C5, whose error correction properties may be utilized in the receiver, in order to ensure reliable operation of NIC.

The NIC sending function has to recognize when the difference between the applicable clock speed of the GSM network and the interface speed generates a positive or negative whole bit requirement. When this positive or negative condition occurs, the NIC codewords specified in GSM 04.21 are used to transport this condition to the receiving NIC function. Transmission of the codeword shall clear the positive or negative condition related to that codeword at the sending function. The sending function shall not send more than one positive or negative compensation within a contiguous period of time corresponding to 10 000 user data bits minus the number of user data bits necessary to make up an even number of V.110 frames between compensation (NIC compensation is coded in two V.110 frames). This results from the requirements to compensate for maximum clock differences of  $\pm 100$  parts per million. If the receiving function receives NIC compensations more often than a contiguous period of time corresponding to 10 000 user data bits, there is no guarantee that data will not be lost.

The NIC receiving function has to provide the capability to support the compensation requirements of the sending function. This compensation is managed by manipulating the clock speed of the interface, within the standard constraints of that interface.

Overall, the compensation functions have to be capable of managing clock tolerances of  $\pm 100$  parts per million.

Action on loss of synchronization.

If five consecutive NIC multiframes have incorrect framing bit values in E7, the receiver shall stop applying clocking compensation to the received data. Resynchronization will be attempted and compensation will resume when synchronization is achieved.

### 9.2.4 Non-transparent service support

NOTE: See GSM 03.10.

GSM 08.20 identifies the corresponding necessary support concerning the rate adaptation scheme to be utilized on the BS-MSC link.

#### 9.2.4.1 MSC-IWF Rate adaptation scheme

This will be the same as for the transparent case.

#### 9.2.4.2 Protocol layer structure in the MSC/IWF

GSM 03.10 identifies the protocol layer structures for the non-transparent case, the physical layer to the PSTN is provided by means of a modem.

#### 9.2.4.3 Re-constitution of user data

GSM 04.22 refers to the frame of user data in the radio link protocol. The layer 2 relay functions in the MS and the MSC/IWF (identified in GSM 03.10) contain the mechanism for packing and unpacking the user data into the L2R protocol data units.

#### 9.2.4.4 Layer 2 relay functionality

Specific functionality is required of the L2R dependant upon the service which is being requested to be supported. The selection of the appropriate L2R function will be determined by the MSC/IWF on the basis of the bearer capability information signalled in either the call set-up request, or call confirmation messages. The prime information element being transparent or non transparent service indication. In addition the particular L2R function will be selected on the basis of the users layer 2 indication - type of protocol to be terminated and mode of flow control to be applied (see appropriate clauses of the 07 series).

The specific interaction between the L2R function and the RLP function and the L2R frame structure will be the same as that detailed in the annex to the appropriate GSM 07 series.

#### 9.2.4.5 In band signalling mapping flow control

This entails the L2R function providing the means of controlling and responding to flow control functions of the modem plus any synchronization requirements related to flow control. For synchronous services flow control is covered by the protocol indicated, whereas for asynchronous services a specific rule applies for flow control (see GSM 07.01).

The flow control function chosen will be dependent upon the information contained or not contained in the "user information layer 2" information element of the GSM BC received from the MS.

If flow control is provided, irrespective of the type used the L2R function must:

- (a) provide immediate indication of flow control to the fixed network on receipt of flow control request from the MS;

and/or

- (b) provide immediate indication of flow control to the MS on receipt of flow control request from the fixed network i.e. in the next available L2R status octet to be transmitted.

Where in-band (X-on/X-off) flow control is in use, then the X-on/X-off characters will not be passed across the radio interface.

For outband flow control refer to subclause 9.2.4.9.

If no flow control is provided, the involved end systems are responsible for performing in-band flow control on their own by taking into account the buffer capacity of the MSC/IWF stated below.

##### 9.2.4.5.1 Conditions requiring flow control towards the fixed network

The L2R function will initiate flow control - if flow control is present - in the following circumstances:

- 1) The transmit buffer reaches a preset threshold (BACK PRESSURE).
- 2) The L2R function receives an explicit "flow control active" indication.

No flow control initiation/removal will take place at the L2R function and loss of data may occur if no flow control is provided.

On removal of buffer congestion or receipt of L2R "flow control inactive" the flow control will be removed.

#### **9.2.4.5.2 Conditions requiring flow control towards the MS**

The L2R function will transmit to the MS an explicit "flow control active indication" if flow control is provided in the following circumstances:

- 1) If the receive buffer from the radio side reaches a preset threshold (BACK PRESSURE).
- 2) If a flow control indication is received from the fixed network customer. On receipt of this flow control indication, transmission of data from the receive buffers towards the fixed network terminal is halted.

On removal of the buffer congestion or fixed network flow control indication, the L2R function will send a "flow control inactive" indication towards the MS. In addition, for the fixed network indication, transmission of data from the receive buffers will be restarted.

If no flow control is provided at the L2R function, no flow control initiation/removal will take place by the MSC/IWF. Data might be lost without any indication by the MSC/IWF to the end systems involved.

#### **9.2.4.6 Data buffers**

##### **9.2.4.6.1 Transmit buffers (towards MS)**

Incoming data from the fixed network customer shall be buffered such that if the MSC/IWF is unable to transfer data over the radio path the data is not lost.

The buffer shall be capable of holding [16-32 kbits]. When the buffer is half full flow control towards the fixed network shall be initiated if flow control is provided as per subclause 9.2.4.5.1.

##### **9.2.4.6.2 Receive buffers (from MS)**

Incoming data from the MS is buffered such that if the fixed network terminal is unable to accept the data then it is not lost.

The buffer shall be capable of holding [16-32 kbits] of data. When the buffer becomes half full, the L2R function will send a "flow control active" indication towards the MS if flow control is provided at the L2R function, as per subclause 9.2.4.5.2.

#### **9.2.4.7 Transportation of the Break condition**

The "BREAK" condition must be recognized by the L2R function and passed immediately to the MS. The L2R will generate a "BREAK" condition towards the fixed network on receipt of a break indication from the MS. The action of the "BREAK" on the L2R transmit and receive and the length of the "BREAK" signal to be generated towards the fixed network is described in GSM 07.02.

#### **9.2.4.8 In band signalling mapping modem status information**

Status information from the modem will be carried by the L2R function to/from the L2R function in the terminal adaptation function. The MSC/IWF is not intended to utilize this information for any purpose. The use of "Data carrier detect" or "clear to send" by the terminal adaptation function to determine PSTN link establishment or failure is not utilized by the MSC/IWF; e.g. call clearing, in event of line failure, will be generated normally by the MS and not by the MSC/IWF.

#### 9.2.4.9 Support of out-band flow control

Out-band flow control in case of PSTN requires V.42 functionality of the modem (refer to GSM 07.01).

If this functionality is requested by the MS but cannot be provided by the MSC/IWF or the remote (fixed network) modem for any reason, the call shall be supported without V.42 functionality (fall back to the non-error correction mode according to V.42).

This implies that no flow control initiation/removal (refer to subclause 9.2.4.5.1) is possible towards the fixed network. In this case the L2R transmit buffers in the IWF (towards the MS, refer to subclause 9.2.4.6.1) shall overbridge temporary throughput problems on the radio interface and the case where the MS initiates flow control. The IWF however shall release the connection if an overflow of these buffers occurs in order to prevent loss of data.

#### 9.2.4.10 Establishment of end-to-end terminal synchronizations

Prior to exposing the traffic channel of a PLMN connection to transmission of user data, the controlling entities of the connection have to assure of the availability of the traffic channel. This is done by a so called synchronization process:

- starting on the indication of "physical connection established" resulting from the PLMN-inherent outband signalling procedure. This indication is given on sending the message CONNECT in case of MOC, CONNECT ACKNOWLEDGEMENT in case of MTC and MODIFY COMPLETE (which is sent after reception of the ASSIGN COMPLETE message) in case of in-call modification;
- ending by indicating the successful execution of this process to the controlling entity, which then takes care of the further use of the in-band information (data, status).

Network interworking within an MSC/IWF is concerned with the terminating side (to the MS) and the transit side (to the fixed network) of a connection. Both sides have to be treated individually related to the synchronization process.

With respect to the terminating side the procedure is as follows:

- Waiting for the RLP link establishment by the MT (in addition the MSC/IWF may initiate the RLP establishment).

Depending upon implementation - CT108 will be turned ON to enable the autocalling/autoanswering function of the selected modem either when the RLP has been established or in parallel to RLP establishment. If CT 108 is turned ON in parallel to the RLP establishment, the modem connection may be established before the RLP is established. In this case, data received from the transit side during RLP establishment shall be stored within the L2R buffers until the RLP establishment at the terminating side has been finished. When the RLP has been established, the information from/to the RLP including status changes will be mapped by the L2R entity applicable to the particular bearer capability.

It should be noted that in a GSM-PLMN V.-series and X.-series interfaces are only supported in full duplex mode. Thus the call control phase can be mapped almost completely to the signalling procedure (the S-bits during the call control phase are irrelevant). However, the "ready for data" condition (i.e. CT106/109, in case of V.-series interface, and I-circuit, in case of X.-series interface) is derived directly from the traffic channel (see also filtering of channel control information).

### 9.3 Interworking Alternate Speech / Data Calls

Data in this context is defined here to mean 3.1 kHz Ex PLMN, or Facsimile Group 3.

#### 9.3.1 Alternate Speech/Data Interworking

##### 9.3.1.1 General

The procedure for the alternate speech/data bearer services is invoked at MS-MSC link during the call set-up phase. This service is invoked by indication of repeated bearer capability information elements in the setup message and/or call confirmed message respectively (preceded by a repeat indicator "circular"), one indicating speech and the other indicating the specific data service, as for normal data calls. The data service requested will be indicated by the information transfer capability, either "3.1 kHz audio Ex PLMN" and the specific user data rate etc. or "facsimile group 3", as for normal data calls. The bearer capability first indicated i.e. speech or 3.1 kHz Audio Ex PLMN, etc. determines the first selection required of the network by the subscriber. Depending on the type of service requested and direction of call establishment (MO/MT, see relevant clauses of GSM 07 series) low layer and high layer capabilities may also be included. The MSC/IWF will perform both compatibility checking and subscription checking on both sets of capabilities as for normal data calls. If either the subscription check or the compatibility check fails then the call will be rejected. The only exception to this is when TS61/TS62 negotiation takes place, see GSM 07.01.

The applicable rules for provision of supplementary services are laid down in GSM 02.04.

The "speech" phase of the call, when invoked is handled by the transcoder and will utilize normal telephony teleservice interworking requirements and mobile network capabilities. This includes any requirements for echo cancellers etc. as indicated in subclause 9.1. The "3.1 kHz Audio Ex PLMN" and "facsimile group 3" phase of the call, when invoked, will utilize the appropriate data interworking capability (IWF including modem) and may use either the transparent or non-transparent mobile network capability.

The network shall provide, for service and operational reasons, a rapid and reliable changeover of capability upon request from the mobile user. This changeover may involve the disabling, by-passing or introduction of particular network functions (e.g. speech coder, modem etc.) and change of the channel configuration on the radio interface. This changeover is initiated on the receipt of the "MODIFY" message (see GSM 04.08) from the mobile station. The network itself will not initiate a changeover.

##### 9.3.1.2 Mobile originated PSTN terminated calls

The call is set up in the normal manner (but with repeated bearer capability information elements as described in subclause 9.3.1.1 and handled by the MSC/IWF as indicated in the general subclause.

##### 9.3.1.3 PSTN originated mobile terminated calls

The call set up request for this particular service is performed in a similar manner to that indicated in subclause 9.2 for normal PSTN originated calls.

When multiple MSISDNs are used by the HLR ("Multi-numbering scheme"), two GSM BC-IE (contents in principle according to GSM 07.01, facsimile group 3 constitutes an exception, coded as per GSM 04.08) preceded by a repeat indicator "circular" are passed to the VLR in the MAP operation "provide roaming number" exceptionally for facsimile group 3 where only one GSM BC-IE with the ITC value set to "alternate speech/facsimile group 3, starting with speech" is needed. The VLR stores this information against the MSRN.

When the call arrives at the visited MSC this information is retrieved from the VLR and sent to the MS in the setup message as defined in GSM 07.01.

If the ITC of the GSM BC-IE retrieved from the VLR has the value "alternate speech/facsimile group 3, starting with speech" this GSM BC-IE has to be mapped to two GSM BC-IEs (preceded by a repeat indicator "circular"), one representing speech, the other representing facsimile group 3. The order in which these two GSM BC-IEs are sent towards the MS, in the setup message, is a network option.

In order to allow auto answering mode for the data phase (i.e. the call starts automatically with the data phase), the MS can reflect back to MSC the dual Bearer Capability in the Call Confirm message with the BC elements interchanged to those in the original Call Set-up message (i.e. data element first or negotiate to facsimile only, see subclause 9.2.2 and GSM 07.01). In all other aspects it is handled as indicated for mobile originated.

NOTE: However, the PLMN specific parameters "connection element" and "radio channel requirements" of the retrieved GSM BC-IE may be modified, or added in line with the principles identified in subclause 9.2.2.

When a single MSISDN is allocated to the subscriber ("single numbering scheme"), the call is handled as described in case b) of subclause 9.2.2. In the "call confirmed" message, however, two GSM BC-IEs are preceded by a repeat indicator "circular", with the first GSM BC-IE indicating the initial phase of the connection.

### 9.3.2 Speech followed by data interworking

#### 9.3.2.1 General

The set up and selection of interworking function for this service is the same as that indicated for the alternate speech/data service. The service will be indicated by repeated GSM BC-IEs, (the first indicating speech and the second indicating the data service) with the information transfer capability "3.1 kHz audio Ex PLMN" and the specific data service parameters as for normal data calls. The GSM BC-IEs are preceded by a repeat indicator "sequential". The only difference in this service is that speech will always be the first bearer capability selection and once the changeover command "MODIFY" message is received from the mobile station then all network resources associated with the handling of the speech call may be released for reallocation to other calls, i.e. they will not be required again in the handling of this call. Both mobile originated and terminated are dealt with as detailed in subclauses 9.3.1.2 and 9.3.1.3.

## 10 Interworking to the ISDN

The interworking to the ISDN is specified on the principle of the network supporting standardized associated signalling protocol as outlined in clause 2, i.e. DSS1 and ISUP. An ISDN not complying with this definition differs - for the purpose of this TS - in that it does not support the compatibility information to that degree necessary for deducing a GSM Basic Service. These networks will find their reflection in the following where those implications are to be set out.

The calling address sent in a mobile originated call to the ISDN is always the basic MSISDN even if the ISDN user has to use a different MSISDN (multi numbering scheme, see subclause 9.2.2 case a) for a mobile terminated call (call back) as only the basic MSISDN is available at the VLR (see GSM 09.02).

The scope of this clause is to describe the handling of the content of the Information Elements where "content" is understood to be the value of the parameter fields of the Information Elements, namely BC-IE, HLC and LLC, after the length indicator. For the transport of these Information Elements within the PLMN refer to GSM 09.02.

### 10.1 Speech Calls

Since at the interworking point the transcoder provides for A law PCM at 64 kbit/s, no particular interworking is required. It is anticipated that the ISDN Teleservice Telephony and ISDN Bearer Service speech, respectively would be used. Transmission aspects are covered in GSM 03.50. Any further requirements are a national matter.

### 10.2 Data Calls

In this case it is assumed that the ISDN bearer service 3.1 kHz audio shall only be interworked by means of a modem pool in the PLMN. If a network operator provides this facility, then the MSC/IWF operation will be similar to that described for interworking to the PSTN.



## 10.2.1 Network interworking mobile originated

Low layer compatibility checking of the mobile originated call is carried out by the MSC/IWF to determine the appropriate bearer service selection in the ISDN. This will entail the MSC/IWF in mapping appropriately the GSM BC-IE to the ISDN BC-IE (bearer capability information element). If it is not possible for the MSC/IWF to provide a bearer service match, then the MSC/IWF shall fail the call and indicate the reason to the user.

The MS shall provide further compatibility information (LLC/HLC-IEs) if required for defining end-to-end compatibility.

As well as compatibility checking, subscription checking should be performed.

### 10.2.1.1 Circuit switched calls

Where the bearer capability information indicates that the call is a circuit switched unrestricted digital call, then the MSC/IWF shall select the appropriate rate adapted ISDN bearer service.

The selection of the MSC/IWF will be by means of the bearer capability information within the call set up message. The mobile subscriber shall be able to select the unrestricted digital capability, which the MSC/IWF will map to the same capability in the ISDN call set up message. If an interworking point is encountered within the ISDN which does not support this service request, then either a call release message including an appropriate error cause or progress message is returned to the PLMN, indicating that the ISDN network is unable to support the service requested. In the case of a call release message the network shall release the call. In the case of progress message the network releases the call or forwards it (see GSM 04.08) to the mobile which will release the call.

### 10.2.1.2 Packet calls

The mobile network offers only Bm channel access for the packet mode service. The ISDN offers both B and D channel access for the packet mode service. The interworking of mobile packet service calls is described in GSM 09.06.

## 10.2.2 Network interworking mobile terminated

This clause describes the interworking of calls where the calling subscriber can communicate ISDN compatibility information with exhaustive contents for deducing a GSM Basic Service to a PLMN (gateway MSC/interrogating node) i.e. by means of ISDN signalling.

The GMSC has to perform a mapping of the received Basic Service Information for the transport to the HLR, for details of this transport refer to GSM 09.02.

Compatibility checking of the low layers of the ISDN originated call is carried out by the MSC/IWF to determine the appropriate bearer service selection in the PLMN. This will entail the MSC/IWF in mapping appropriately the ISDN BC/LLC-IE to the GSM BC-IE.

As well as compatibility checking, subscription checking should be performed. If either the subscription check or the compatibility check fails then the call will be rejected.

For ISDN originated calls it will not be possible to signal mobile specific requirements e.g. transparent/non transparent, full/half rate channel. Therefore the MSC/IWF shall select a default setting appropriate to the visited PLMN's network capabilities. In general it will be beneficial, where a network supports both full and half rate channels and transparent/non transparent capabilities, to indicate so in the appropriate GSM BC field of GSM 04.08. The mobile subscriber has the option to indicate in the call confirmation message a change to this default setting according to the rules specified in GSM 07.01. The appropriate MSC/IWF shall be selected on the basis of this requirement.

At call Set-up, the interrogating node passes in the "send routing information" to the HLR, the ISDN BC1, LLC and HLC received in the initial address message. The coding of these parameters must comply with ETS 300 102-1 edition 1, with one exception: for the mapping of the parameter modem type to/from the ISDN BC-IE, refer to tables 6A and 6B.

According to the contents of the Compatibility Information, i.e. the ISDN BC, LLC and HLC received, the HLR applies one of the following alternatives:

1. No ISDN BC is received, or one from which a GSM Basic Service cannot be deduced with the information Transfer Capability field set to "3.1 kHz audio" but without any associated modem type<sup>1</sup> in the ISDN BC or LLC, or without HLC indication of group 3 facsimile. Two cases have to be considered:

- a) The called MSISDN has one or two corresponding GSM BC-IE(s) stored in the HLR (see option a) of 9.2.2); then the service attached to this number in the HLR tables is applicable and the corresponding GSM BC-IE(s) is passed to the VLR in "provide roaming number". See figure 6.

If two GSM BC-IE have to be sent to the VLR they are preceded by a repeat indicator information element according to 04.08. These three information elements shall be included within the MAP parameter "GSM Bearer Capability" of the message "Provide Roaming Number".

NOTE: For the case of two GSM BC-IEs see subclause 10.3.

- b) The called MSISDN has no corresponding GSM BC-IE(s) stored in the HLR (see option b in subclause 9.2.2). In this case no GSM BC is passed to the VLR in the "provide roaming number" message.

2. Compatibility Information is received from which a GSM Basic Service can be deduced, i.e. the ITC field in the ISDN BC received is "unrestricted digital" and the fields for the applicable user layer 1 protocol and user rate are available (either in the ISDN BC or LLC), or the ITC field is "3.1 kHz audio", and a modem type, user rate, etc. is indicated but the HLC does not indicate "facsimile group 3". The received ISDN BC (and possibly LLC plus HLC) is then considered applicable regardless of the kind of MSISDN received (GSM BC associated or not) and either the equivalent GSM BC or the original ISDN BC/LLC is sent to the VLR. Additionally in both cases the originally received HLC may also be sent to the VLR, see figure 7.

When the HLR interworks with a phase 1 VPLMN (VLR/VMSC), then the HLR shall convert the ISDN BC to the equivalent GSM BC, and forward to the VLR. In this case however no LLC can be forwarded.

3. Compatibility Information is received from which the GSM Teleservice category Facsimile transmission can be deduced i.e. the ITC field in the ISDN BC received is "3.1 kHz audio" and the HLC indicates "facsimile group 3" (see figure 7), the following two cases have to be considered:

- a) The called MSISDN has a corresponding GSM BC stored in the HLR (either stating TS 61 or TS 62). In this case the service attached to the MSISDN in the HLR tables is applicable and the corresponding GSM BC is passed to the VLR in the "provide roaming number" message, see also subclause 10.3.1.3.
- b) The called MSISDN has no corresponding GSM BC stored in the HLR. In this case the HLR shall forward the appropriate GSM BC to the VLR in line with the subscribers subscription to teleservice 61 or 62.

For TS 61 the value of the GSM BC-IE parameter "Information Transfer Capability" shall be set to "alternate speech/facsimile group 3, starting with speech".

In both cases the HLC IE should be passed to the VLR in the "provide roaming number" message.

Alternatively the HLR may forward the originally received ISDN/LLC/HLC, when interworking with a phase 2 VLR.

---

<sup>1</sup> "Modem type" in connection with the ITC value "3.1 kHz audio" means hereafter that either an ISDN BC modem type value is present or the autobaoding modem function is indicated (see note 16 of table 6B)

4. In the case where Compatibility Information received does not allow for deducing a GSM Bearer Service but an ISDN BC is received with the ITC field indicating "unrestricted digital", but without the fields indicating applicable "user layer 1 protocol", user rate, etc., neither in the ISDN BC or the ISDN LLC then the following shall apply. The call is managed as an udi call according to subclause 9.2.2, i.e. either the "multi numbering" or "single numbering" scenario is applied depending on which capability is provided by home PLMN/HLR.

At the VMSC, when the incoming call arrives, the LLC/HLC and the GSM or ISDN BC associated with the MSRN is retrieved from the VLR. LLC and HLC are sent with the GSM BC in general to the MS at call set-up. In particular, however the following rules apply:

1. If the Initial Address Message (IAM) contains no ISDN BC and there is no GSM or ISDN BC/LLC/HLC retrieved from the VLR, the call is handled as subclause 9.2.2 case b.
2. If there is no ISDN BC in the IAM but a GSM or ISDN BC/LLC/HLC was signalled in the "provide roaming number" message, the retrieved GSM or ISDN BC/LLC/HLC applies.
3. If there is an ISDN BC in the IAM with the ITC field set to "3.1 kHz audio" but without any associated modem type or indication of facsimile group 3 in the HLC, the GSM or ISDN BC/LLC/HLC retrieved from the VLR is considered as applicable when it exists. If no GSM or ISDN BC is retrieved from the VLR, the call is handled as in subclause 9.2.2 case b.
4. If the ISDN BC received in the IAM has the ITC field set to the value "unrestricted digital information" and the fields for the applicable "user layer 1 protocol" and "user rate" are available (either in the ISDN BC or ISDN LLC), or if 3.1 kHz audio and a modem type is indicated, this ISDN BC is applicable regardless of what has been retrieved from the VLR. In this case the ISDN BC has to be mapped to an appropriate GSM BC (refer to table 6B-09.07).
5. If the ISDN BC received in the IAM has the ITC field set to the value "3.1 kHz audio" and a HLC "facsimile group 3" is indicated, the GSM BC retrieved from the VLR is applicable when it exists. If a GSM BC-IE with the parameter "information transfer capability" set to "alternate speech/facsimile group 3, starting with speech" (stating TS61) is retrieved from the VLR, this shall be mapped to two GSM BC-IE preceded by a repeat indicator, one representing speech, the other representing facsimile group 3.

When no GSM BC is retrieved from the VLR, either two GSM BCs preceded by a repeat indicator (stating teleservice 61), or a single GSM BC-IE (stating TS 62), are sent in the setup message, depending whether TS 61 or TS 62 is subscribed (see also subclause 10.3.1.3).

In case of TS 61, the order in which the two GSM BC-IEs are sent towards the MS, in the setup message, is a network option.

6. If the ISDN BC received in the IAM has a ITC value "unrestricted digital information" but without applicable "user layer 1 protocol" and "user rate", etc. fields, neither in the ISDN BC nor ISDN LLC, then the GSM or ISDN BC/LLC retrieved from the VLR is applicable, if available otherwise subclause 9.2.2 case b applies.

In case of an ISDN BC/LLC/HLC was attached to the MSRN this has to be mapped to an appropriate GSM BC (refer to table 6B-09.07). However in both cases (GSM or ISDN BC attached) the PLMN specific parameters of the GSM BC-IEs may be added/modified in line with procedures identified in subclause 9.2.2.

In all cases when no GSM or ISDN BC is retrieved from the VLR and no ISDN Compatibility information allowing deduction of a GSM Bearer Service is available, then no GSM BC is inserted by the VMSC and subclause 9.2.2 case b applies.

The mapping between GSM and ISDN BCs is shown in table 6/09.07.

Mobile terminated, ISDN originated call compatibility Information provided not exhaustive for deducing a GSM Bearer Service, but Information Transfer Capability = 3.1 kHz audio, no modem type and no HLC IE indicating facsimile group 3. HLR stores GSM BC against MSISDN number multi-numbering scheme.

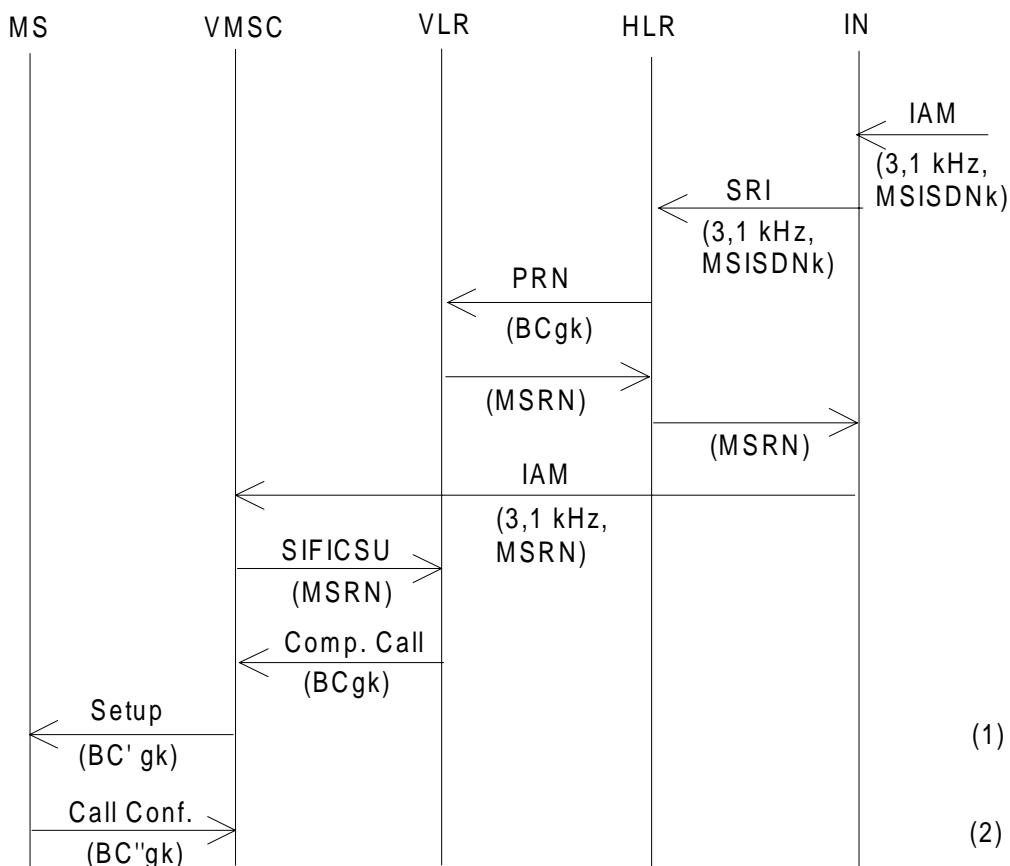

Abbreviations: see figure 2.

- NOTES:
- (1) The parameters "connection element" and "radio channel requirements" of BCgk may be provided/modified according to MSC's capabilities/preferences.
  - (2) In the "Call Confirm" message, the MS may modify some parameters of the GSM BC. See subclause 9.2.2.

Figure 6

Mobile terminated, ISDN originated call compatibility Information provided not exhaustive for deducing:

- a GSM Bearer Service; or
- Information Transfer Capability = 3.1 kHz audio with HLC IE indicating facsimile group 3.

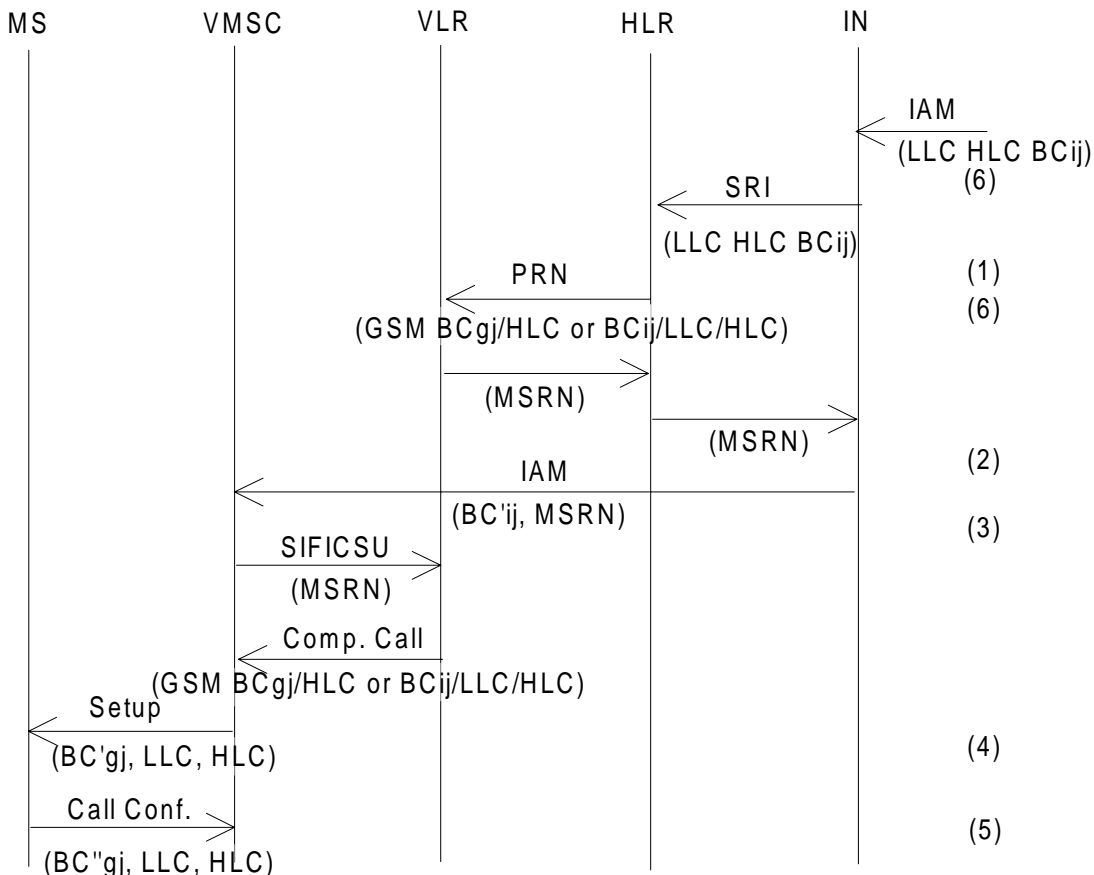

- NOTES:
- (1) BCij denotes ISDN ETS 300 102-1 BC\*; BCgj is the corresponding GSM BC.
  - (2) Assumes signalling capabilities permit the transfer of BC between IN and VMSC. If this is not the case, the VLR uses the stored BC/LLC/HLC.
  - (3) BC'ij denotes BCij as maybe modified by intervening networks.
  - (4) The parameters "connection element" and "radio channel requirements" of BCgj may be provided/modified according to MSC's capabilities/preferences.
  - (5) In the "Call Confirm" message, the MS may modify some parameters of the BC. See subclause 9.2.2.
  - (6) For details on how the BC, HLC, and LLC are transported, refer to GSM 09.02.

\* HLC and LLC refers to ISDN values.

Abbreviations: See figure 2.

Figure 7

The following tables (6A + 6B) show that only the ISDN BC is used for mapping (exceptions are indicated).

NOTE: The ISDN/GSM BC-IE mapping shall be performed as specified in tables 6A and 6B. This must be done to allow setup of a compatible end-to-end connection between two Mobile Stations or one Mobile Station and an ISDN terminal.

It is to be noted that this mapping for some services (e.g. modem calls) will mean that more octets than allowed according to ETS 300 102-1 edition 1 will be sent towards the ISDN. Some calls might therefore fail, depending on the ISDN network/terminal implementation.

In the following table the comparison is drawn between parameters in the GSM call set up request message and that of the ISDN call set up request message. In some cases no comparable values are available and these will be marked as such. In these cases reference will need to be made to the table of network interworking in GSM 09.07 to identify the appropriate choice. In some cases it is not necessary to support a particular option, and in this case those parameters will be annotated appropriately.

**Table 6A-09.07: Comparable setting of parameters in GSM 04.08 and ETS 300 102-1 (ETSI ISDN user to network signalling) Mobile Originated**

Octet	GSM 04.08 parameter value as in GSM 07.01	Octet	ETS 300 102-1 parameter value
1	<b>Bearer Capability IEI</b>	1	<b>Bearer Capability IEI</b>
2	<b>Length of BC contents</b>	2	<b>Length of BC contents</b>
3 #7..6	<b>Radio channel requirement</b> half rate channel full rate channel dual, full, rate preferred dual, half rate preferred		No comparable field
3 #4	<b>Coding Standard</b> GSM standard coding	3 #7..6	<b>Coding Standard</b> CCITT standardized coding
3 #4	<b>Transfer mode</b> circuit mode packet mode (note7)	4 #7..6	Transfer mode circuit mode packet mode
3 #3..1	<b>Information transfer capability</b> speech unrestric. digital 3.1 kHz audio ex PLMN facsimile group 3 (note 1)	3 #5..1	<b>Information transfer capability</b> speech unrestricted digital 3.1 kHz audio see table 4 in GSM 09.07
4 #6..5	<b>Structure</b> SDU integrity unstructured	4a #7..5	<b>Structure</b> (note 4)

Table 6A-09.07 (continued)

4 #4	<b>Duplex mode</b> half duplex full duplex	5d #7	<b>Duplex mode</b> half duplex full duplex
4 #3	<b>Configuration</b> point-to-point	4a #4..3	<b>Configuration</b> (note 4) point-to-point
4 #1	<b>Establishment</b> demand	4a #2..1	<b>Establishment</b> (note 4) demand
4	<b>NIRR</b> (note 12) meaning Data $\leq$ 4.8kbps, FR nt, 6kbps radio interface is requested		No comparable field
5 #5..4	<b>Rate adaptation</b> no rate adaptation (note 2) V.110/X.30 rate adaptation  CCITT X.31 flag stuffing  No comparable value (note 11)	5 #5..1	<b>User information layer 1 protocol</b> no comparable value CCITT standardized rate adaption V.110/X.30 CCITT standardized rate adaption X.31 flag stuffing Recommendation G.711 $\mu$ law Recommendation G.711 A law (note 3) Recommendation G.721 32 kbit/s ADPCM and I.460
5 #3..1	<b>Signalling access protocol</b> I.440/I.450 X.21 X.28, ded.PAD, indiv.NUI X.28, ded PAD, univ.NUI X.28, non-ded PAD X.32		No comparable field
6 #1	<b>Synchronous/asynchronous</b> synchronous asynchronous	5a #7	<b>Synchronous/asynchronous</b> synchronous asynchronous
6 #5..2	<b>User info. layer 1 protocol</b> default layer 1 protocol	5 #5..1	<b>User info. layer 1 protocol</b> see clause under rate adaptation for GSM 04.08 above
6a #7	<b>Number of stop bits</b> 1 bit 2 bits	5c #7..6	<b>Number of stop bits</b> 1 bit 2 bits
6a #6	<b>Negotiation</b> In band neg. not possible no comparable value	5a #6	<b>Negotiation</b> In band neg. not possible In band neg. possible (note 10)
6a #5	<b>Number of data bits</b>  7 bits 8 bits	5c #5..4	<b>Number of data bits excluding parity if present</b> 7 bits 8 bits

Table 6A-09.07 (concluded)

6a #4..1	<b>User rate</b> 0.3 kbit/s 1.2 kbit/s 2.4 kbit/s 4.8 kbit/s 9.6 kbit/s 12 kbit/s (note 7) 1.2 kbit/s / 75 bit/s no comparable value	5a #5..1	<b>User rate</b> 0.3 kbit/s 1.2 kbit/s 2.4 kbit/s 4.8 kbit/s 9.6 kbit/s 12 kbit/s 75 bit/s / 1.2 kbit/s Ebits or inband negotiation (note 10)
6b #7..6	<b>Intermediate rate</b> 8 kbit/s 16 kbit/s	5b #7..6	<b>Intermediate rate (note 13)</b> 8 kbit/s or not used 16 kbit/s or not used
6b #5	<b>NIC on Tx</b> does not require requires (note7)	5b #5b	<b>NIC on Tx</b> does not require requires (note 8)
6b #4	<b>NIC on Rx</b> cannot accept can accept (note 7)	5b #4	<b>NIC on Rx</b> cannot accept can accept (note 8)
6b #3..1	<b>Parity information</b> odd even none forced to 0 forced to 1	5c #3..1	<b>Parity information</b> odd even none forced to 0 forced to 1
6c #7..6	<b>Connection element</b> transparent non-transparent (RLP) both, transp. preferred both, non-transp. preferred		No comparable field
6c #5..1	<b>Modem type</b> none V.21 V.22 V.22bis V.23 V.26ter V.32 modem for undef. interface autobauding type 1	5d #6..1	<b>Modem type (note 9)</b> no comparable value (note 5) V.21 V.22 V.22bis V.23 V.26ter V.32 No comparable value (note 5) No comparable value (note 5, note 10)
7 #5..1	<b>User info. layer 2 protocol</b> X.25 link level ISO 6 429, codeset 0 COPnoFICt videotex profile 1 (note 7) X.75 layer 2 modified (note 7)	6	<b>User info. layer 2 protocol (note 6)</b> X.25 link level no comparable value no comparable value no comparable value no comparable value

The application rules for coding the information elements ISDN-BC/LLC/HLC as set out in ETR 018 and ETS 300 102-1 shall apply.



Other field values in the ISDN BC-IE of ETS 300 102-1 not supported in GSM 04.08 are:

Information transfer rate: In this case default 64 kbit/s is selected.

Symmetry: In this case default bi-directional symmetric is selected for all user data rates (note 5).

Flow control on transmission: This shall be selected if outband flow control applies.

Flow control on reception: This shall be selected if outband flow control applies.

NOTE: Outband flow control is indicated by the absence of the UIL2P parameter for non-transparent connections.

V120 rate adaption octets: Rate adaptation header, multiple frame establishment, mode of operation, logical link identifier negotiation, assignor/assignee, in band/out band negotiation - This protocol is not supported by GSM.

User information layer 3 protocol:

Octet 7 shall not be sent unless specific application rules are given for particular cases (to be defined by GSM). End-to-end significant User Information layer 3 protocol shall be sent by LLC.

NOTE 1: In the case where GSM BC "Information Transfer Capability" indicates "Facsimile group 3" and only a single GSM BC is contained in the call set-up request then this shall be mapped to an ISDN BC with:

Coding standard:	CCITT
Information Transfer capability	3.1 kHz audio
Transfer mode	circuit
Information transfer rate	64 kbit/s
User layer 1 protocol	G711 A Law

and

- If an HLC is not present, the network will insert a "Facsimile group 2/3" HLC.
- If an HLC element is present, the network will pass it through unmodified.

In the case where GSM BC "Information Transfer Capability" indicates "Facsimile group 3" and two GSM BCs are contained in the call set-up request, then the same ISDN BC as mentioned above is created. If the first GSM BC indicates "facsimile group 3" an HLC "facsimile group 2/3" will be inserted by the network (if not received from the MS). However if the first GSM BC indicates "speech", the network will not send a HLC, irrespective where a HLC was received from the MS or not.

NOTE 2: This value is present in combination with information transfer capability parameter value "3.1 kHz audio Ex PLMN" or "facsimile group 3" and will therefore be mapped to the value "CCITT Recommendation G.711 A Law" of the ETS 300 102-1 parameter user layer 1 protocol (see note 3).

NOTE 3: The value "CCITT Recommendation G.711 A Law" applies only when the ETS 300 102-1 parameter information transfer capability indicates "3.1 kHz audio" or "speech".

NOTE 4: Octets 4a and 4b shall not be included because default values apply.

NOTE 5: In this case octet 5d shall not be included.

NOTE 6: Octet 6 shall not be sent unless specific application rules are given for a particular case (GSM specified). End-to-end significant user information layer 2 protocol shall be sent by LLC.

- NOTE 7: Not used for currently defined Bearer Services and Teleservices.
- NOTE 8: These values will only be set if the "Information Transfer Capability" indicates "3.1 kHz audio", synchronous data transmission is used and octet 5b of the ISDN BC is present.
- NOTE 9: The mapping of the modem type shall be according to ETS 300 102-1/prA1.
- NOTE 10: The GSM BC-IE parameter value "autobauding modem type 1" will be mapped to the ISDN BC-IE parameter values "inband negotiation possible" and "user rate indicated by E-bits specified in CCITT Rec I.460 or may be negotiated inband" (octet 5a of ISDN BC-IE).
- NOTE 11: The ITC value of the GSM BC-IE "speech", "3.1 kHz audio Ex PLMN" will indicate these requirements.
- NOTE 12: For the use of NIRR see GSM 07.01.
- NOTE 13: The value of the Intermediate Rate field of the ISDN Bearer Capability information element shall only depend on the values of the User Rate and the Information Transfer Capability in the same information element. The correspondence is:

Intermediate Rate = 16 kbit/s if User Rate = 9.6 kbit/s.

Intermediate Rate = 8 kbit/s otherwise.

In case of Audio calls the value of the Intermediate Rate may be set to "not used".

Table 6B-09.07: Comparability and Mapping of bearer capability parameter values according to ETS 300 102-1 and GSM 04.08 within the HLR for a mobile terminated Call

Octet	ETS 300 102-1 parameter value	Octet	GSM 04.08 parameter value
1	<b>Bearer Capability IEI</b>	1	<b>Bearer Capability IEI</b>
2	<b>Length of BC contents</b>	2	<b>Length of BC contents</b>
	no comparable field	3 #7..6	<b>Radio channel requirement</b> (note 1) half rate channel full rate channel both, half rate preferred both, full rate preferred
3 #7..6	<b>Coding standard</b> CCITT standardized coding	3 #5	<b>Coding standard</b> GSM standardized coding
3 #5..1	<b>Information transfer capability</b> speech unrestricted digital 3.1 kHz audio no comparable value restricted digital inform. 7 kHz audio video	3 #3..1	<b>Information transfer capability</b> speech unrestricted digital 3.1 kHz audio ex PLMN (note 2) facsimile group 3 (note 3) not supported
4 #7..6	<b>Transfer mode</b> circuit mode packet mode	3 #4	<b>Transfer mode</b> circuit mode circuit mode
4 #5..1	<b>Information transfer rate</b> 64 kbit/s		no comparable field
4a #7..5	<b>Structure</b> default 8 kHz integrity SDU integrity unstructured	(4) 4 #6..5	<b>Structure</b> no comparable value no comparable value SDU integrity (note 9) unstructured (note 5)
4a #4..3	<b>Configuration</b> point-to-point	4 #3	<b>Configuration</b> point-to-point (*)
	No comparable field	4 #2	<b>NIRR</b> (note 17) No meaning Data ≤ 4.8kbps, FR nt, 6 kbps radio interface requested
4a #2..1	<b>Establishment</b> demand	4 #1	<b>Establishment</b> demand (*)
4b #7..6	<b>Symmetry</b> bi-directional symmetric		no comparable field
4b #5..1	<b>Information transfer rate (dest-&gt;orig.)</b> - 64 kbit/s		no comparable field

Table 6B-09.07 (continued)

5 #5..1	<b>User information layer 1 protocol</b> no comparable value CCITT V.110 / X.30 CCITT G.711 A-law CCITT X.31 flag stuffing	5 #5..4	<b>Rate adaption</b> no rate adaption (note 11) V.110/X.30 rate adaption no comparable value CCITT X.31 flag stuffing
	no comparable field	5 #3..1	<b>Signalling access protocol</b> I.440/I.450 X.21 X.28, ded.PAD, indiv.NUI X.28, ded.PAD, univ.NUI X.28, non-ded.PAD X.32
	see above	6 #5..2	<b>User information layer 1 protocol</b> default layer 1 protocol
5a #7	<b>Synchronous / asynchronous</b> synchronous asynchronous	6 #1	<b>Synchronous/asynchronous</b> synchronous asynchronous
5a #6	<b>Negotiation</b> not possible inband neg, possible (note 16)	6a #6	<b>Negotiation</b> not possible no comparable value
5a #5..1	<b>User rate</b> 0,3 kbit/s 1,2 kbit/s 2,4 kbit/s 4,8 kbit/s 9,6 kbit/s 12 kbit/s rate is indicated by Ebit as specified in CCITT rec. I.460 0.6 kbit/s 3.6 kbit/s 7.2 kbit/s 8 kbit/s 14.4 kbit/s 16 kbit/s 19.2 kbit/s 32 kbit/s 48 kbit/s 56 kbit/s 64 kbit/s 0.1345 kbit/s 0.1 kbit/s 75 bit/s / 1.2 kbit/s 1.2 kbit/s / 75 bit/s 0.110 kbit/ 0.115 kbit/s 0.2 kbit/s	6a #4..1	<b>User rate</b> 0,3 kbit/s 1,2 kbit/s 2,4 kbit/s 4,8 kbit/s 9,6 kbit/s 12 kbit/s (note 13) (note 16)  not supported

Table 6B-09.07 (continued)

5b #7..6	<b>Intermediate rate</b> not used (note 18) 8 kbit/s 16 kbit/s 32 kbit/s	6b #7..6	<b>Intermediate rate</b> (note 6) 8 or 16 kbit/s 16 kbit/s not supported
5b #5	<b>NIC on Tx</b> (note 14) does not require requires	6b #5	<b>NIC on Tx</b> does not require requires (note 13)
5b #4	<b>NIC on Rx</b> (note 14) cannot accept can accept	6b #4	<b>NIC on Rx</b> cannot accept can accept (note 13)
5b #3	<b>Flow control on Tx</b> (note 15) Not Required Required		no comparable field
5b #2	<b>Flow control on Rx</b> (note 15) Cannot Accept Accept		no comparable field
5c #7..6	<b>Number of stop bits</b> 1 bit 2 bits not used 1.5 bits	6a #7	<b>Number of stop bits</b> 1 bit 2 bits no comparable value not supported
5c #5..4	<b>Number of data bits</b> 7 bits 8 bits not used 5 bits	6a #5	<b>Number of data bits</b> 7 bits 8 bits no comparable value not supported
5c #3..1	<b>Parity information</b> odd even none forced to 0 forced to 1	6b #3..1 odd	<b>Parity information</b> even none forced to 0 forced to 1
	no comparable field	6c #7..6	<b>Connection element</b> (note 1) transparent non-transparent (RLP) both, transp. preferred both, non-transp preferred
5d #7	<b>Duplex mode</b> half duplex full duplex	4 #4	<b>Duplex mode</b> half duplex (note 13) full duplex (*)

Table 6B-09.07 (concluded)

5d #6..1	<b>Modem type</b> reserved V.21 V.22 V.22bis V.23 V.26ter V.32 V.26 V.26bis V.27 V.27bis V.29 V.35 no comparable value	6c #5..1	<b>Modem type</b> (note 12) none (note 7) V.21 V.22 V.22bis V.23 V.26ter V.32 not supported  autobauding type 1 (note 16)
6 #5..1	<b>User information layer 2 protocol</b> (note 10) Q.921 (I.441) X.25, link level no comparable value	7	<b>User information layer 2 protocol</b> (note 8) no comparable value X.25, link level ISO 6 429, codeset 0
7	<b>User information layer 3 protocol</b> (note 10) Q.931 (I.451) X.25, packet level		not supported

General notes:

1. Other ETS 300 102-1 parameter values than those listed in the table, if indicated in the BC-IE, will be rejected by clearing the call.
2. Only the GSM 04.08 parameter values listed in the table may be generated (comparable values) during a mobile-terminated call by mapping the ETS 300 102-1 parameter values, exception see (10).
3. According to ETS 300 102-1 and GSM 04.08, respectively, the octets are counted from 1 to n onwards; the bit position in a particular octet is indicated by #x..y, with {x,y} = 1..8 (bit 1 is the least and bit 8 the most significant bit).
4. If octets 5 to 5d of the ISDN BC are absent but present in the LLC, the LLC octets should apply for the mapping as indicated above.
5. If within the ISDN BC the parameters information transfer capability indicates "3.1 kHz audio" and user layer 1 protocol indicates "G711 A Law" but no modem type is available and the HLC does not indicate "facsimile group 3", octets 5 to 5d of the LLC, if available, apply for the above mapping procedure.
6. The number of octets which shall be encoded for the GSM BC-IE must comply to encoding rules in GSM 04.08 and the combination of the different parameter values shall be in accordance to GSM 07.01.

Notes regarding the mapping:

- (\*) This GSM 04.08 parameter value is inserted, if the comparable ETS 300 102-1 parameter value is missing.
- (1) This GSM 04.08 parameter value is inserted according to user rate requirements and network capabilities / preferences.
- (2) This GSM 04.08 parameter value is inserted, if the information transfer capability in ISDN BC is "3.1 kHz audio" and a comparable modem type is specified.
- (3) This GSM 04.08 parameter value is inserted, if the information transfer capability is "3.1 kHz audio" and the content of the HLC-IE, if any, indicates "facsimile group 2/3", (for details refer to subclause 10.2.2 case 3 for HLR action and case 5 for VMSC action). Note that via MAP the value "alternate speech/facsimile group 3 - starting with speech" shall be used, when TS 61 applies.
- (4) If octet 4a is omitted the default condition according to ETS 300 102-1 applies.
- (5) The GSM 04.08 parameter value shall be set to "unstructured" where the network indicates connection element "transparent".
- (6) The value of the Intermediate Rate field of the GSM Bearer Capability information element shall only depend on the values of the user rate or the radio channel requirement in the same information element. If the connection element is "transparent", the value is 16 kbit/s and 8 kbit/s otherwise. For any other connection element setting the value is 16 kbit/s, if the radio channel requirements are "full rate" or "dual, full rate preferred", or "dual, half rate preferred", and 8 kbit/s, if the radio channel requirements is "half rate".
- (7) This GSM 04.08 parameter value is inserted, if the GSM BC parameter "Information Transfer Capability" indicates "Unrestricted digital information", "facsimile group 3" or "alternate speech/facsimile group 3, starting with speech".
- (8) Where the network indicates "asynchronous" and connection elements "non-transparent", "both, transparent preferred" or "both, non-transparent preferred", then the GSM BC should be forwarded without parameter user information layer 2 protocol, see also (10).
- (9) Where the network indicates connection elements "non transparent" "both, transparent preferred" or "both, non transparent preferred" the value of the parameter structure shall be set to "SDU Integrity".
- (10) Mapping of parameter values of this octet to GSM BC parameters and values are subject to specific application rules, i.e. unless otherwise explicitly stated in an appropriate TS mapping to GSM BC parameters shall not take place.
- (11) This value shall be used when the value of the GSM BC parameter "Information Transfer Capability" indicates the value "3.1 kHz audio ex PLMN", "facsimile group 3" or "alternate speech/facsimile group 3, starting with speech" which is reserved for MAP operations.
- (12) The modem encoding of both ETS 300 102-1/prA1 and ETS 300 102-1 version 1 shall be accepted and mapped according to GSM 04.08.
- (13) Value not used for currently defined bearer services and Teleservices.
- (14) NIC is only supported for "3.1 kHz Ex PLMN audio" interworking with synchronous data transmission.
- (15) Because the required flow control mechanism can not be indicated to the MS (refer to GSM 07.01), the network shall check if the flow control mechanism selected by the MS and indicated in the CALL CONFIRMED message suits to the requirements requested by the ISDN terminal adaptor. In case of a mismatch the call shall be released in the IWF.

Because an asymmetric flow control mechanism (with respect to transmitting and receiving side) is not supported in GSM PLMNs, the different values of the ISDN BC-IE parameters "flow control on Tx" and "flow control on Rx" shall be interpreted in the following way:

- "Flow control on Rx" set to "accepted" matches with "outband flow control", irrespective of the value of the parameter "flow control on Tx";
  - "Flow control on Rx" set to "not accepted" and "flow control on Tx" set to "not required" matches with "inband flow control" and "no flow control";
  - where "Flow control on Rx" is set to "not accepted" and "flow control on Tx" to "required" the call shall be released by the IWF.
- (16) If in case of 3.1 kHz audio interworking "inband negotiation possible" is indicated and the parameter user rate is set to "rate is indicated by E bits specified in Rec I.460 or may be negotiated inband" the user rate in the GSM BC-IE shall be set according to a network preferred value, whereas the preferred value of the Radio Channel Requirement shall be considered. If parameter ISDN-BC modem type is present, its value shall be ignored. The parameter GSM-BC modem type shall be set according to the user rate in case of connection element "transparent" and to "autobauding type 1" in case of connection element "non transparent", "both, transparent preferred" or "both, non transparent preferred".  
For unrestricted digital interworking the call shall be rejected if these values are indicated.
- (17) For the use of NIRR see GSM 07.01. The VMSC shall set this parameter dependent upon its capabilities and preferences.
- (18) Only applicable if the parameter ISDN-BC ITC indicates "3.1 kHz audio".

#### **10.2.2.1 Circuit switched calls**

Where the bearer capability information indicated that the call is a circuit switched unrestricted digital call, then the MSC/IWF shall select the appropriate rate adapted PLMN bearer service.

#### **10.2.2.2 Packet calls**

The mobile network offers only Bm channel access for the packet mode service. The ISDN offers both B and D channel access for the packet mode service. The interworking of mobile packet calls is described in GSM 09.06.

#### **10.2.3 Transparent service support (see GSM 03.10)**

GSM 08.20 identifies the rate adaptation scheme to be utilized on the BS to MSC link. The transcoding function will generate the 64 kbit/s rate adapted format utilizing the 8 and 16 kbit/s intermediate data rates. The MSC - MSC/IWF will utilize the same rate adaptation scheme as that indicated in GSM 08.20, i.e. adapted to 64 kbit/s.

##### **10.2.3.1 MSC - IWF rate adaptation scheme**

This link consists of a 64 kbit/s channel with the information, both user data and in band parameter information (where provided) rate adapted in conformance to GSM 08.20.

##### **10.2.3.2 Rate adaptation process in MSC/IWF**

When interworking to the unrestricted digital bearer service then no further rate adaptation will be necessary within the MSC/IWF. When interworking to the 3.1 kHz audio service, then the same process as for the PSTN case is necessary.

##### **10.2.3.3 Mapping of signalling MS/MSC/IWF to modem interface requirements**

Only necessary for the 3.1 kHz audio interworking case (see subclause 9.2.3.3).



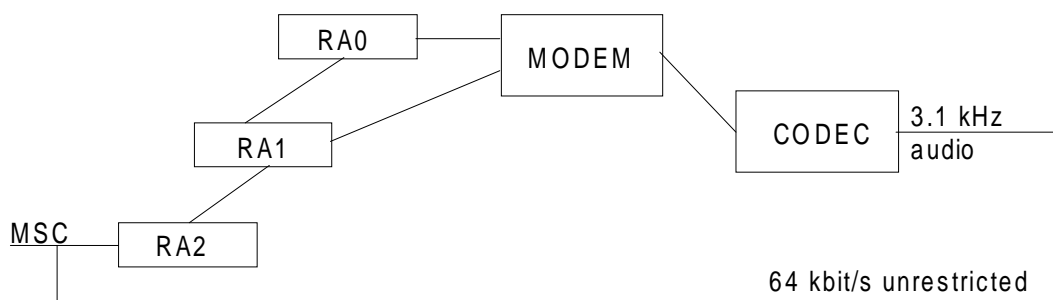

**Figure 8: Protocol structure in the MSC/IWF (transparent)**

#### 10.2.3.4 Establishment of end-to-end terminal synchronizations

Prior to exposing the traffic channel of a PLMN connection to transmission of user data, the controlling entities of the connection have to assure of the availability of the traffic channel. This is done by a so called synchronizations process:

- starting on the indication of "physical connection established" resulting from the PLMN-inherent outband signalling procedure. This indication is given on sending the message CONNECT in case of MOC, CONNECT ACKNOWLEDGEMENT in case of MTC and MODIFY COMPLETE (which is sent after reception of the ASSIGN COMPLETE message) in case of in-call modification;
- ending by indicating the successful execution of this process to the controlling entity, which then takes care of the further use of the inband information (data, status).

Network interworking within an MSC/IWF is concerned with the terminating side (to the MS) and the transit side (to the fixed network) of a connection. Both sides have to be treated individually related to the synchronizations process.

With respect to the terminating side the procedure is as follows:

- sending of synchronizations pattern 1/OFF (all data bits "1"/all status bits "OFF") to the MS using the RA1/RA2 rate adaptation function;
- searching for detection of the synchronizations pattern 1/OFF from the MS within valid V.110 frames. This implies that the E1, E2 and E3 bit of the V.110 frame shall be checked for the appropriate user rate in order to distinguish the synchronization pattern from the BSS idle data frame.

In case of interworking to the ISDN "3.1 kHz audio" bearer service the synchronization process is as for the PSTN interworking case (see subclause 9.2.3.4). In case of interworking to the ISDN unrestricted digital bearer service the following synchronization process has to be performed:

When the 1/OFF from the MS has been recognized as a steady state, the MSC/IWF continues sending the synchronizations pattern 1/OFF to the MS unless a timer T expires. From this time the information on the receiving lines from the MS and from the fixed network are directly mapped to the respective sending lines.

During the synchronizations process described above, i.e. while the synchronizations pattern is being sent by the MSC/IWF, the MSC/IWF will not send the V110 frame structure to the ISDN transit network. Once timer "T" expires the synchronizations pattern will continue to be transmitted from the MSC/IWF to the MS, however, the MSC/IWF will start sending the V110 frames received from the MS to the ISDN transit network. The MSC/IWF will start looking for the ISDN frame alignment to be received from the ISDN. On recognizing frame alignment the MSC/IWF will cease sending its synchronizations pattern to the MS and connect the ISDN through to the MS.

It should be noted that in a GSM PLMN V.-series and X.-series interfaces are only supported in full duplex mode. Thus the call control phase can be mapped almost completely to the signalling procedure (the S-bits during the call control phase are irrelevant). However, the "ready for data" condition (i.e. CT106/109, in case of V.-series interface, and I-circuit, in case of X.-series interface) is derived directly from the traffic channel (see also filtering of channel control information).

**10.2.3.5 Network independent Clocking (NIC)**

Due to the incompatibility between the ISDN and the GSM requirements for NIC interworking is not provided between these two formats. As such no NIC function is required in providing interworking to the ISDN. In this case, the IWF shall disregard the value of bits E4, E5, E6 and E7 in the data transmission phase.

**10.2.4 Non-transparent service support (see GSM 03.10)**

GSM 08.20 identifies the corresponding necessary support concerning the rate adaptation scheme to be utilized on the BS-MSC link.

**10.2.4.1 MSC - IWF Rate adaptation scheme**

This will be the same as for the transparent case.

**10.2.4.2 Protocol layer structure in the MSC/IWF**

GSM 03.10 identifies the protocol layer structure for the non-transparent case, the MSC/IWF provides the inverse of the action in the terminal adaptation function.

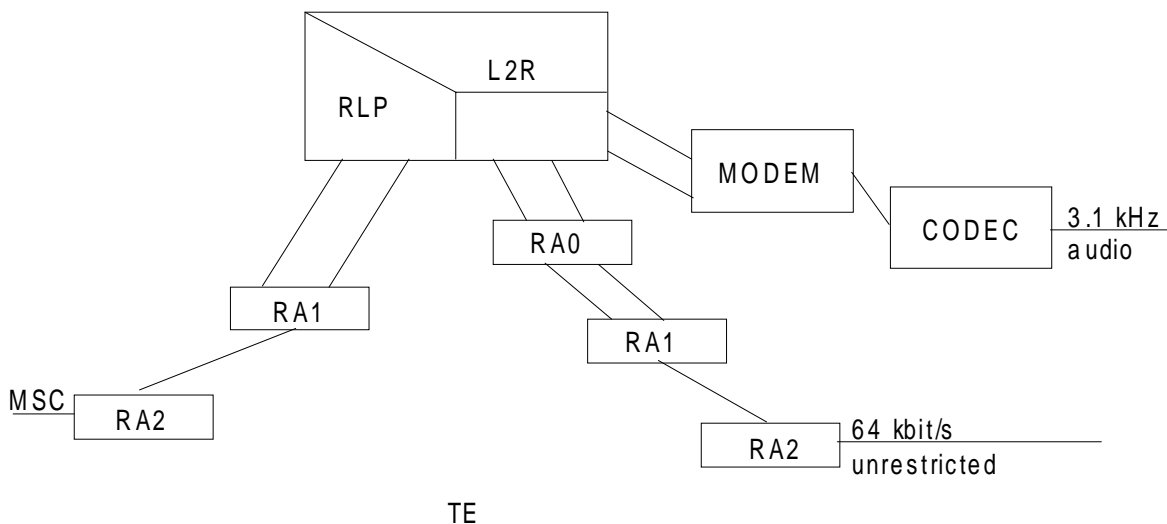

**Figure 9: Protocol structure in the MSC/IWF (non-transparent)**

**10.2.4.3 Re-constitution of user data**

GSM 04.22 refers to the frame of user data in the radio link protocol. The layer 2 relay functions in the MS and the MSC/IWF (identified in GSM 03.10) contain the mechanism for packing and unpacking the user data into the L2R protocol data units.

**10.2.4.4 Layer 2 relay functionality**

Specific functionality is required on the L2R dependant upon the service which is being requested to be supported. The selection of the appropriate L2R function will be determined by the MSC/IWF on the basis of the bearer capability information signalled in the call set-up request, or call confirmation message. The prime information element being transparent or non transparent service indication. In addition the particular L2R function - type of protocol to be terminated and mode of flow control to be applied (see appropriate clauses in 07 series) - will be selected on the basis of the user's layer 2 indication.

The specific interaction between the L2R function and the RLP function and the L2R frame structure will be the same as that detailed in the annex to the appropriate GSM 07 series.

#### 10.2.4.5 In band signalling mapping flow control

This entails the L2R function providing the means of controlling and responding to flow control function of the modem (or in the rate adapted frame) plus any synchronizations requirements related to flow control. for synchronous services flow control is covered by the protocol indicated whereas for asynchronous services a specific rule applies for flow control (see GSM 07.01).

In case of interworking to the ISDN "3.1 kHz audio" bearer service the flow control process is as for the PSTN interworking case (see subclause 9.2.4.5). In case of interworking to the ISDN unrestricted digital bearer service the following procedures apply:

The flow control function chosen will be dependent upon the availability of the "user information layer 2" information element of the GSM BC and if available its value.

The outband flow control will be by means of the "X" bit in the V.110 frame to the ISDN.

If flow control is provided irrespective of the type used, the L2R function must:

- (a) provide immediate indication of flow control to the fixed network on receipt of flow control request from the MS;

and/or

- (b) provide immediate indication of flow control to the MS on receipt of flow control request from the fixed network i.e. in the next available L2R status octet to be transmitted.

Where in band (X-on/X-off) flow control is in use, then the X-on/X-off characters will not be passed across the radio interface.

If no flow control is provided the involved end systems are responsible for performing in-band flow control on their own by taking into account the buffer capacity of the MSC/IWF as stated below.

##### 10.2.4.5.1 Conditions requiring flow control - if flow control is provided - towards the fixed network

The L2R function will initiate flow control in the following circumstances:

- 1) The transmit buffer reaches a preset threshold (BACK PRESSURE).
- 2) The L2R function receives a "flow control active" indication.

On removal of buffer congestion or receipt of L2R "flow control inactive" the flow control will be removed.

No flow initiation/removal will take place at the L2R function and loss of data may occur, if no flow control is provided.

##### 10.2.4.5.2 Conditions requiring flow control towards the MS

The L2R function will transmit to the MS a "flow control active indication", if flow control is provided, in the following circumstances:

- 1) If the receive buffer from the radio side reaches a preset threshold (BACK PRESSURE).
- 2) If a flow control indication is received from the fixed network customer. On receipt of this flow control indication, transmission of data from the receive buffers towards the fixed network terminal is halted.

On removal of the buffer congestion or fixed network flow control indication, the L2R function will send a "flow control inactive" indication towards the MS. In addition, for the fixed network indication, transmission of data from the receive buffers will be restarted.

If no flow control is provided at the L2R function, no flow control initiation/removal will take place by the MSC/IWF. Data might be lost without any indication by the MSC/IWF to the end systems involved.

#### **10.2.4.6 Data buffers**

##### **10.2.4.6.1 Transmit buffers (towards MS)**

Incoming data from the fixed network customer shall be buffered such that if the MSC/IWF is unable to transfer data over the radio path the data is not lost.

The buffer shall be capable of holding [16-32 kbits]. When the buffer is half full flow control towards the fixed network shall be initiated if flow control is provided as per subclause 10.2.4.5.1.

##### **10.2.4.6.2 Receive buffers (from MS)**

Incoming data from the MS is buffered such that if the fixed network terminal is unable to accept the data then it is not lost.

The buffer shall be capable of holding [16-32 kbits] of data. When the buffer becomes half full, the L2R function will send a "flow control active" indication towards the MS if flow control is provided at the L2R function, as per subclause 10.2.4.5.2.

#### **10.2.4.7 BREAK Indication**

The BREAK indication is managed as detailed in subclause 9.2.4.7.

#### **10.2.4.8 Signalling mapping modem status information or in band rate adapted frame information**

Status information from the modem or within the rate adapted frame, will be carried by the L2R function, in the MSC/IWF, to/from the L2R function in the terminal adaptation function. The MSC/IWF is not intended to utilize this information for any purpose. The use of "Data carrier detect" or "clear to send" by the terminal adaptation function to determine ISDN link establishment or failure is not utilized by the MSC/IWF e.g. call clearing, in event of line failure, will be generated normally by the MS not the MSC/IWF.

#### **10.2.4.9 Support of out-band flow control**

Out-band flow control in case of unrestricted digital requires V.110 TA to TA "end-to-end flow control" as defined therein. If this functionality is requested by MS but cannot be supported by the MSC/IWF for any reason (refer also to note 15 of table 6B-09.07) the call pending shall be released.

#### **10.2.4.10 Synchronizations**

In case of interworking to the ISDN "3.1 kHz audio" bearer service the synchronization process is as for the PSTN interworking case (see subclause 9.2.3.4). In case of interworking to the ISDN unrestricted digital bearer service the following synchronization process has to be performed:

##### **10.2.4.10.1 V110 Frame synchronizations**

The ISDN frame synchronizations will need to be mapped to the frame synchronizations utilized on the MSC/IWF to MSC link.

##### **10.2.4.10.2 RLP Frame start indication**

The frame start indication is defined in GSM 08.20. Link establishment and frame error recovery are defined in GSM 04.22.

##### **10.2.4.10.3 L2R Frame synchronizations**

The synchronizations of user data and its interaction between the L2R function and RLP function are defined in GSM 07 series.

#### 10.2.4.10.4 Establishment of end-to-end terminal synchronizations

Prior to exposing the traffic channel of a PLMN connection to transmission of user data, the controlling entities of the connection have to assure of the availability of the traffic channel. This is done by a so called synchronization process:

- starting on the indication of "physical connection established" resulting from the PLMN-inherent outband signalling procedure. This indication is given on sending the message CONNECT in case of MOC, CONNECT ACKNOWLEDGEMENT in case of MTC and MODIFY COMPLETE (which is sent after reception of the ASSIGN COMPLETE message) in case of in-call modification;
- ending by indicating the successful execution of this process to the controlling entity, which then takes care of the further use of the in-band information (data, status).

Network interworking within an MSC/IWF is concerned with the terminating side (to the MS) and the transit side (to the fixed network) of a connection. Both sides have to be treated individually related to the synchronization process.

With respect to the terminating side the procedure is as follows:

- Waiting for RLP link establishment by the MT (in addition the MSC/IWF may initiate the RLP link establishment).

Depending upon implementation the sending of V.110 frame structure to the ISDN transit network and the start of looking for ISDN frame synchronization may be performed either RLP establishment or in parallel to the RLP establishment. In case of the parallel establishment, data received from the transit side during RLP establishment shall be stored within the L2R buffers until the RLP establishment at the terminating side has been finished. When the RLP has been established and on recognizing frame alignment the information from/to the RLP is mapped by the L2R entity applicable to this particular bearer capability.

It should be noted that in a GSM/PLMN, V.-series and X.-series interfaces are only supported in full duplex mode. Thus the call control phase can be mapped almost completely to the signalling procedure (the S-bits during the call control phase are irrelevant). However, the "ready for data" condition (i.e. CT106/109, in case of V.-series interface, and I-circuit, in case of X.-series interface) is derived directly from the traffic channel (see also filtering of channel control information).

#### 10.2.5 DTE/Modem interface (Filtering)

The DTEs taken into account for the PLMN at the MS side conform to CCITT's DTE/Modem interface specifications, which assume basically an error-free environment, i.e.:

- limited distance, point-to-point local interconnection of the interface circuits for data and status;
- steady state signalling.

The envisaged use of these DTE's in the PLMN environment leads to the exposure of these "interconnections" - which may, in the ISDN case, lead to the ISDN Rate Adaptation rather than to a Modem in the MSC/IWF - to the PLMN Radio Channel. To assure proper operation even under these conditions appropriate measures have to be taken. In the "non-transparent case" the RLP satisfies the requirement for both data and status lines. In the "transparent" case, the:

- data line aspects have to be dealt with end-to-end between the users; while
- status line aspects are of concern to the network which are dealt with in the following.

The use of the channel control information for the remote control of the DTE/Modem control interchange-circuits between the MS and the MSC/IWF (the conveyance of which is supported by the rate adaptation scheme adopted for PLMN application) requires alignment to the particular transmission occurrences in the traffic channel to be taken into account within the PLMN. In principle this can be best achieved by:

- relying only on the PLMN outband signalling as far as connection control is concerned;
- eliminating the dependence upon the transmission of channel control information via the radio link.

Support for this strategy is given to a certain extent by the confinement of PLMN data connections to:

- full duplex operation;
- switched service (demand access);
- mapping of connection-control relevant conditions of the DTE/DCE control interchange-circuits to/from outband PLMN signalling according to GSM 04.08 after successful traffic channel synchronization (refer to subclause 10.2.3.4);
- flow control by a network entity supported only in non-transparent mode;
- support of connections with the same user data rate only (no TA to TA end-to-end flow control in case of transparent mode).

The only DTE/Modem control interchange-circuit conditions, which actually are not covered by the above confinements, are the indications of readiness for data transmission, i.e. CT106/109 in case of V.-series interface and I-circuit of X.-series interface. As the effect of a condition change of the afore-mentioned DTE/Modem interchange-circuits depends on the:

- phase within the course of the connection;
- direction of change (ON-OFF or OFF-ON).

The required precaution to be applied (Filtering) must be determined individually in view of:

- function deduced from the change;
- resilience of the connection needed;
- error condition possibly invoked due to a delay in performing the condition change of the control interchange circuit;
- potential loss of performance in connection usage.

The details of the filtering function are laid down in GSM 07- series.

### **10.3 Interworking Alternate speech data calls**

Alternation between speech and unrestricted digital (BS61) and speech followed by unrestricted digital (BS 81) are not applicable for interworking with the ISDN, since the alternate speech/unrestricted bearer service is currently not specified in the ISDN.

A BS 61 or BS 81 call where one of the two bearer capability information elements indicates the ITC value "unrestricted digital information" shall therefore be rejected.

### **10.3.1 Alternate speech data bearer interworking**

#### **10.3.1.1 General**

The procedure for the alternate speech/data service is invoked at the MS-MSC link during the call set-up phase. This service is invoked by indication of repeated bearer capability information elements in the setup message and/or call confirmed message, respectively (preceded by a repeat indicator "circular"), one indicating speech and the other indicating the specific data service with the ITC, "3.1 kHz audio Ex PLMN" or "facsimile group 3" plus user rate etc., as for normal data calls. The bearer capability first indicated i.e. speech or 3.1 kHz Ex PLMN, etc. determines the first selection required of the network by the subscriber. Depending on the type of service requested and direction of call establishment (MO/MT, see relevant clauses of the 07 series) low layer and high layer capabilities may also be included. The MSC/IWF will perform both compatibility checking and subscription checking for mobile originated calls and optionally for mobile terminated calls (single numbering scheme) on both sets of capabilities as for normal data calls. If either the subscription check or the compatibility check fails then the call shall be rejected. The only exception to this is when TS61/TS62 negotiation takes place, see GSM 07.01.

As regards the supplementary services the application rules are laid down in GSM 02.04.

The speech phase of the call, when invoked, is handled by the transcoder and will utilize the normal telephony teleservice interworking requirements and mobile network capabilities. The 3.1 kHz audio Ex PLMN and Facsimile group 3 phase of the call, when invoked, will utilize the appropriate data interworking capability (e.g. IWF) and may use either the transparent or non-transparent mobile network capability.

The network shall provide, for service and operational reasons, a rapid and reliable changeover of capability upon request from the mobile user. This changeover may involve the disabling, by-passing or introduction of particular network functions (e.g. speech coder, modem etc.) and change of the channel configuration on the radio interface. This changeover is initiated on the receipt of the "MODIFY" message (see GSM 04.08) from the mobile station. The network itself will not initiate a changeover.

#### **10.3.1.2 Mobile originated ISDN terminated**

If one bearer capability information element indicates the ITC value "3.1 kHz audio Ex PLMN" or "facsimile group 3", the call set up is as for the PSTN case. Interworking is provided to the ISDN bearer service 3.1 kHz audio for the whole connection, including the speech phase. The MODIFY message (see GSM 04.08) will be generated by the mobile subscriber. This message is not transmitted to the ISDN, i.e. no outband correlation between the user on the fixed network and the mobile user will be possible. In this instance it is necessary for change of network capabilities to be carried out in the mobile network.

#### **10.3.1.3 ISDN originated mobile terminated**

In principle this is handled as for normal ISDN originated call. In the following however, the different cases are described in more detail:

- a) When the calling user indicates an ISDN BC-IE with an ITC value "3.1 kHz audio" with no other ISDN BC information such as modem type, etc. and the HLC is not "facsimile group 3", i.e. the calls arrive at the GMSC with compatibility information not exhaustive to deduce a GSM Bearer Service the call setup is as for the PSTN case described in subclause 9.2.1.3.
- b) When the calling user however indicates an ISDN BC-IE with an ITC value "3.1 kHz audio" and a HLC "facsimile group 3", i.e. the call arrives at the GSM with compatibility information allowing for deducing the Teleservice "Facsimile transmission", the call setup is as described in subclause 10.2.2 (case 3 in HLR, case 5 in VMSC).

In the information transfer phase the call is dealt with as indicated in the previous clause.

## 10.3.2 Speech followed by data interworking

### 10.3.2.1 General

The set up and selection of interworking function for this service is the same as that indicated for the alternate speech/data service. The service will be indicated by repeated BC-IEs (the first indicating speech and the second indicating the appropriate data service with the ITC "3.1 kHz audio Ex PLMN") and the specific data user rate, etc. as for normal data calls, preceded by a repeat indicator "sequential". The only difference in this service is that speech will always be the first bearer capability selection and once the MODIFY message, see GSM 04.08, is received from the mobile station then all network resources associated with the handling of the speech call may be released for reallocation to other calls, i.e. they will not be required again in the handling of this call. Both mobile originated and terminated are dealt with as detailed in subclauses 10.3.1.2 and 10.3.1.3.

## 11 V.110 Frame Synchronization

Potentially two links are involved in the MSC/IWF regarding the need for V.110 frame synchronization, i.e. the MSC/IWF-BSS interface and the MSC/IWF-ISDN network interface. The MSC/IWF-BSS links are covered by the TSs dealing with the GSM transcoder function (e.g. GSM 08.60). For the MSC/IWF-ISDN network in principle the respective clauses of V.110 apply and are as defined below in subclause 11.2.

### 11.1 Initial V.110 frame synchronization

For transparent/non-transparent and interworking to the PSTN or ISDN the interface to the BSS is managed as follows. As soon as the outband signalling exchange indicates that the traffic channel is available the MSC/IWF will start sending V.110 frames with the frame contents set as indicated in subclause 9.2.3.4 towards the BSS. The MSC/IWF will seek to attain V.110 frame synchronization on the incoming data from the BSS. V.110 synchronization will be considered to be completed in line with the V.110 procedures. The incoming data will only be considered valid once this V.110 frame synchronization procedure is complete.

In the case of interworking to the PSTN V.110 framing is not used towards the PSTN.

In the case of interworking to the ISDN the procedures for initial synchronization for the transparent services are covered in subclause 10.2.3.4 and the non transparent services in subclause 10.2.4.10.4.

### 11.2 Action on loss of V.110 frame synchronization for non transparent services

If loss of frame synchronization is detected from the ISDN, in line with the procedures specified in CCITT V.110, then re-synchronization is initiated on that link in line with the procedures specified in CCITT V.110. No action should be taken by the L2R/RLP on the BSS/MSC link.

If loss of synchronization is detected on the BSS/MSC link then a re-synchronization process should be initiated. However for this link to the MSC/BSS it is only necessary to search for the frame alignment pattern incoming from the MSC/BSS. There shall be no action regarding the outgoing frame towards the BSS/MSC, other than to continue sending the rate adapted RLP frames. Once synchronization has been re-attained the RLP will recover any possible loss of data on the BSS/MSC link. No action shall be taken regarding the frames generated towards the ISDN during the re-synchronization process. L2R function will continue to act as an interface to the ISDN terminal until the link to the MS is re-established.

### 11.3 Action on loss of V.110 frame synchronization for transparent services

If loss of frame synchronization is detected from the ISDN, in line with the procedures specified in CCITT V.110, then re-synchronization is initiated on that link in line with the procedures specified in CCITT V.110. No further action should be taken by the MSC/IWF on the BSS/MSC link or on the outgoing V.110 frames towards the ISDN.

For both PSTN and ISDN, if loss of synchronization is detected on the BSS/MSC link then a re-synchronization process should be initiated. However for this link to the MSC/BSS it is only necessary to search for the frame alignment pattern incoming from the MSC/BSS. There shall be no action regarding the outgoing frame towards the BSS/MSC, other than to continue sending the rate adapted frames made up of the incoming data from the fixed network. Additionally the status bits should continue to be mapped



to the modem/incoming V.110 frame. The data and status bit information will continue to be extracted from the information stream incoming from the BSS as if V.110 frame synchronization was still available. The data stream is passed on towards the fixed network either via the modem (PSTN), or the V.110 frame (ISDN). No action shall be taken regarding the frames generated towards the ISDN during the re-synchronization process.

**Annex A (informative): SDLs**

The following SDLs are intended to assist in the interpretation of the text in subclause 10.2.2 and are not intended to indicate implementation requirements. Therefore these SDLs are informative only.

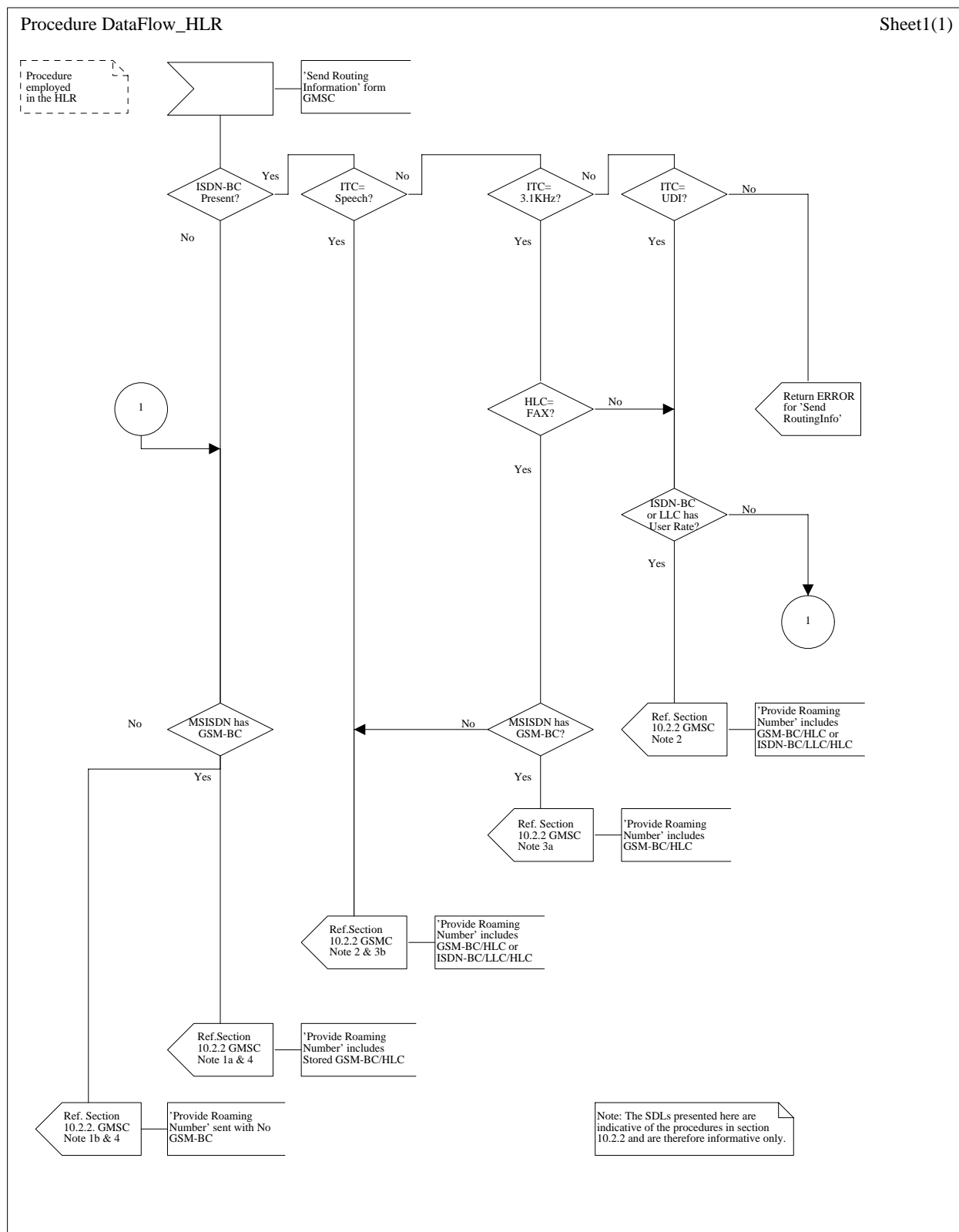

**Figure A-1 (Sheet 1 of 1): Procedures in the HLR**

Procedure DataFlow\_MSC\_VLR

Sheet1(1)

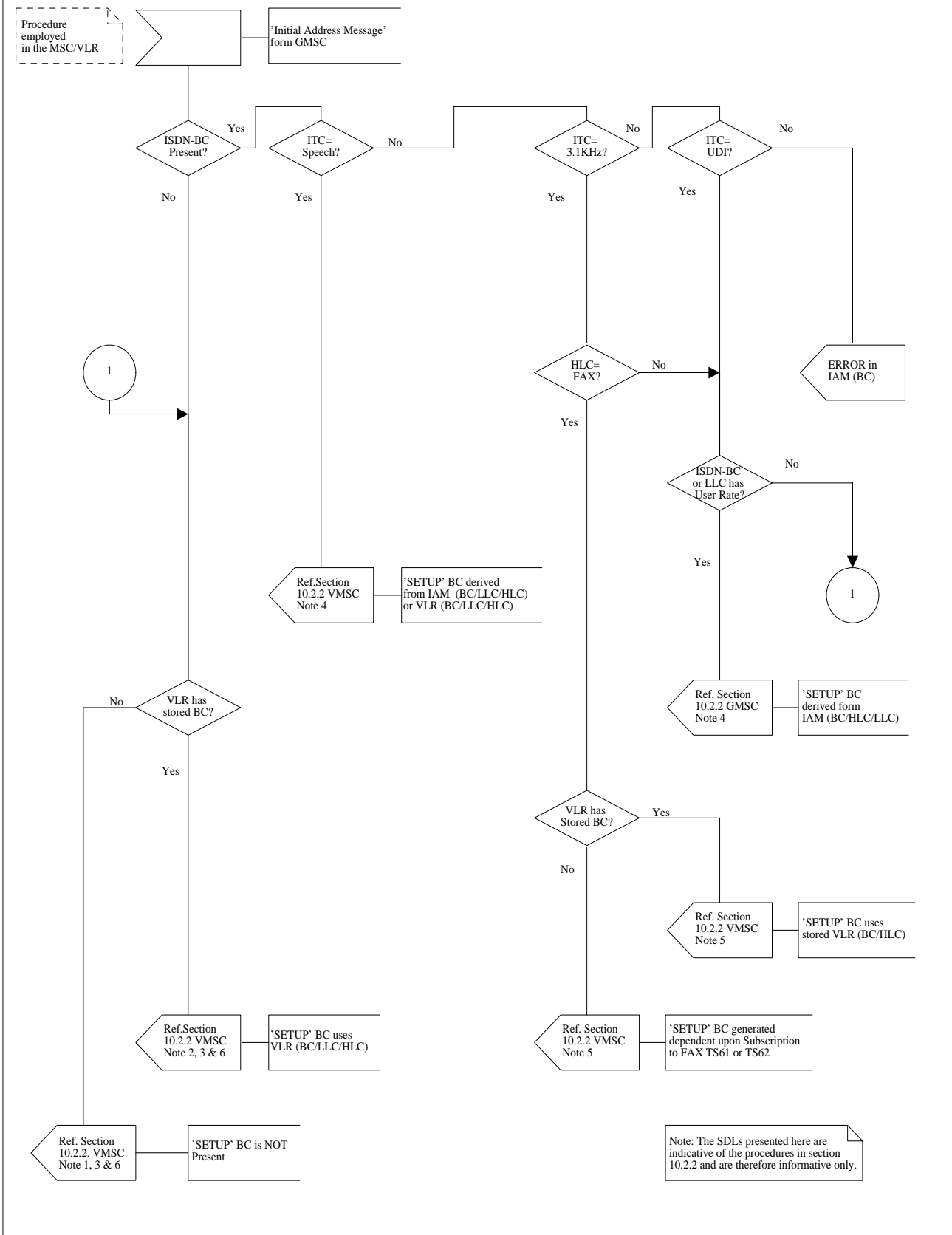

Figure A-2 (Sheet 1 of 1): Procedures in the MSC/VLR

## History

Document history			
October 1994	First Edition		
March 1995	Unified Approval Procedure (Second Edition)	UAP 26:	1995-03-06 to 1995-06-30
May 1995	Unified Approval Procedure (Third Edition)	UAP 29:	1995-05-22 to 1995-09-15
July 1995	Second Edition		
September 1995	Third Edition		
December 1995	Unified Approval Procedure (Fourth Edition)	UAP:40	1995-12-04 to 1996-03-29
May 1996	Fourth Edition		
June 1996	Unified Approval Procedure (Fifth Edition)	UAP 48:	1996-06-03 to 1996-09-27
October 1996	Fifth Edition		
December 1996	Unified Approval Procedure (Sixth Edition)	UAP 60:	1996-12-02 to 1997-03-28
May 1997	Sixth Edition		