



**E**UROPEAN  
**T**ELECOMMUNICATION  
**S**TANDARD

**DRAFT**  
pr **ETS 300 563**

May 1998

**Second Edition**

---

Source: SMG

Reference: RE/SMG-040422PR1

ICS: 33.020

**Key words:** Digital cellular telecommunications system, Global System for Mobile communications (GSM)



**Digital cellular telecommunications system (Phase 2);  
Radio Link Protocol (RLP) for data and telematic services on the  
Mobile Station - Base Station System (MS - BSS) interface  
and the Base Station System - Mobile-services Switching Centre  
(BSS - MSC) interface  
(GSM 04.22 version 4.5.0)**

**ETSI**

European Telecommunications Standards Institute

**ETSI Secretariat**

**Postal address:** F-06921 Sophia Antipolis CEDEX - FRANCE

**Office address:** 650 Route des Lucioles - Sophia Antipolis - Valbonne - FRANCE

**Internet:** [secretariat@etsi.fr](mailto:secretariat@etsi.fr) - <http://www.etsi.fr> - <http://www.etsi.org>

Tel.: +33 4 92 94 42 00 - Fax: +33 4 93 65 47 16

---

**Copyright Notification:** No part may be reproduced except as authorized by written permission. The copyright and the foregoing restriction extend to reproduction in all media.

© European Telecommunications Standards Institute 1998. All rights reserved.



## Contents

Foreword .....	5
1 Scope .....	7
2 Normative references .....	7
2.1 Definitions and abbreviations .....	9
3 Introduction .....	9
4 Frame Structure .....	10
4.1 Basic frame structure .....	10
4.2 RLP header .....	10
4.3 Order of transmission .....	10
4.4 Frame check sequence .....	10
5 Elements and procedure .....	11
5.1 Modes .....	11
5.1.1 Asynchronous Balanced Mode (ABM) .....	11
5.1.2 Asynchronous Disconnected Mode (ADM) .....	11
5.2 Header and parameters .....	11
5.2.1 Generally used bits .....	11
5.2.1.1 Command/response bit, C/R .....	12
5.2.1.2 Poll/Final bit, P/F .....	12
5.2.2 Unnumbered frames, U .....	12
5.2.2.1 Set asynchronous balanced mode SABM (11100) .....	12
5.2.2.2 Unnumbered Acknowledge. UA (00110) .....	13
5.2.2.3 Disconnect, DISC (00010) .....	13
5.2.2.4 Disconnected Mode, DM (11000) .....	13
5.2.2.5 Unnumbered Information, UI (00000) .....	13
5.2.2.6 Exchange Identification, XID (11101) .....	13
5.2.2.7 Test, TEST (00111) .....	15
5.2.2.8 Null information, NULL (11110) .....	15
5.2.3 Supervisory frames, S, and numbered information transfer and supervisory frames combined, I+S .....	15
5.2.3.1 Send Sequence number, N(S) .....	15
5.2.3.2 Receive sequence number, N(R) .....	15
5.2.3.3 Receive ready, RR (00) .....	16
5.2.3.4 Reject, REJ (01) .....	16
5.2.3.5 Receive not ready, RNR (10) .....	16
5.2.3.6 Selective reject, SREJ (11) .....	16
5.3 Error Recovery .....	17
5.3.1 Improper frames .....	17
5.3.2 N(S) sequence error .....	17
5.3.3 Time-out and checkpointing .....	17
5.3.3.1 Treatment of errors during link establishment, link reset and link disconnect .....	17
5.3.3.2 Treatment of errors during numbered information transfer .....	18
5.3.4 Contentious situations .....	18
5.4 List of system parameters .....	18
5.4.1 Timer T1 .....	18
5.4.2 Maximum number of retransmissions N2 .....	18
5.4.3 Maximum number of outstanding I frames k .....	19
5.5 Support for discontinuous transmission (DTX) .....	19
6 Service Definitions .....	20
6.1 Introduction .....	20
6.2 Conventions .....	20

6.3	Queue Model.....	21
6.4	List of Primitives .....	22
6.5	Possible RLP time sequence diagrams .....	23
Annex A (Informative): RLP SDL Diagrams .....		26
A.1	List of RLP entity states .....	27
A.1.1	(main) states .....	27
A.1.2	state variables .....	27
A.2	List of RLP entity events .....	31
Annex B (Informative): Change history .....		63
History .....		64

## Foreword

This draft European Telecommunication Standard (ETS) has been produced by the Special Mobile Group (SMG) of the European Telecommunications Standards Institute (ETSI) and is now submitted for the One-step Approval Procedure (OAP) of the ETSI standards approval process.

This ETS specifies the Radio Link Protocol (RLP) for data transmission over within the digital cellular telecommunications system.

The specification from which this ETS has been derived was originally based on CEPT documentation, hence the presentation of this ETS may not be entirely in accordance with the ETSI rules.

<b>Proposed transposition dates</b>	
Date of latest announcement of this ETS (doa):	3 months after ETSI publication
Date of latest publication of new National Standard or endorsement of this ETS (dop/e):	6 months after doa
Date of withdrawal of any conflicting National Standard (dow):	6 months after doa

Blank page

## 1 Scope

This Specification specifies the Radio Link Protocol (RLP) for data transmission over the GSM PLMN. RLP covers the Layer 2 functionality of the ISO OSI Reference Model (IS 7498). It is based on ideas contained in IS 3309, IS 4335 and IS 7809 (HDLC of ISO) as well as X.25 and Q.92x (LAP-B and LAP-D of CCITT, resp.) RLP has been tailored to the special needs of digital radio transmission. RLP provides to its users the OSI Data Link Service (IS 8886).

RLP is intended for use with non-transparent data-transfer. Protocol conversion may be provided for a variety of protocol configurations. Those foreseen immediately are:

- Character-mode protocols using start-stop transmission (IA5)
- X.25 LAP-B.

For reasons of better presentation, material about protocol conversion has been placed within those Specifications concerned with the relevant Terminal Adaptors, i.e. GSM 07.02 for the asynchronous case and GSM 07.03 for the synchronous case. Care must be taken that that material also applies to Interworking Functions; see GSM 09.04 - 09.07.

## 2 Normative references

This ETS incorporates by dated and undated reference, provisions from other publications. These normative references are cited at the appropriate places in the text and the publications are listed hereafter. For dated references, subsequent amendments to or revisions of any of these publications apply to this ETS only when incorporated in it by amendment or revision. For undated references, the latest edition of the publication referred to applies.

- [1] GSM 01.04 (ETR 100): "Digital cellular telecommunication system (Phase 2); Definitions, abbreviations and acronyms".
- [2] GSM 04.21 (ETS 300 562): "Digital cellular telecommunication system (Phase 2); Rate adaption on the Mobile Station - Base Station System (MS - BSS) interface".
- [3] GSM 07.02 (ETS 300 583): "Digital cellular telecommunication system (Phase 2); Terminal Adaptation Functions (TAF) for services using asynchronous bearer capabilities".
- [4] GSM 07.03 (ETS 300 584): "Digital cellular telecommunication system (Phase 2); Terminal Adaptation Functions (TAF) for services using synchronous bearer capabilities".
- [5] GSM 09.04 (ETS 300 601): "Digital cellular telecommunication system (Phase 2); Interworking between the Public Land Mobile Network (PLMN) and the Circuit Switched Public Data Network (CSPDN)".
- [6] GSM 09.05 (ETS 300 602): "Digital cellular telecommunication system (Phase 2); Interworking between the Public Land Mobile Network (PLMN) and the Packet Switched Public Data Network (PSPDN) for Packet Assembly/Disassembly facility (PAD) access".
- [7] GSM 09.06 (ETS 300 603): "Digital cellular telecommunication system (Phase 2); Interworking between a Public Land Mobile Network (PLMN) and a Packet Switched Public Data Network/Integrated Services Digital Network (PSPDN/ISDN) for the support of packet switched data transmission services".
- [8] GSM 09.07 (ETS 300 604): "Digital cellular telecommunication system (Phase 2); General requirements on interworking between the Public Land Mobile Network (PLMN) and the Integrated Services Digital Network (ISDN) or Public Switched Telephone Network (PSTN)".

- [9] CCITT Recommendation I.440 (Redbook): "ISDN user-network interface data link layer - General aspects".
- [10] CCITT Recommendation I.441 (Redbook): "ISDN user-network interface, data link".
- [11] CCITT Recommendation Q.920 (Redbook): "ISDN user-network interface data link layer - General aspects".
- [12] CCITT Recommendation Q.921 (Redbook): "ISDN user-network interface - data link".
- [13] CCITT Recommendation Q.921bis: "Abstract test suites for LAPD conformance tests".
- [14] CCITT Recommendation Q.922: "ISDN data link layer specification for frame mode bearer services".
- [15] CCITT Recommendation X.25 (Redbook): "Interface between Data Terminal Equipment (DTE) and Data Circuit Terminating Equipment (DCE) for terminals operating in Packet Mode and connected to Public Data Networks by dedicated Circuit".
- [16] ISO/IEC Recommendation 4335: "Information technology - Telecommunications and information exchange between systems - High level data link control (HDLC) procedures - Elements of procedures".
- [17] ISO Recommendation 3309: "Information technology - Telecommunications and information exchange between systems - High level data link control (HDLC) procedures - Frame structure".
- [18] ISO Recommendation 7498: "Information processing systems - Open Systems Interconnection - Basic Reference Model".
- [19] ISO Recommendation 8885: "Information technology - Telecommunication and information exchange between systems - High-level data link control (HDLC) procedures - General purpose XID frame information field content and format".
- [20] ISO Recommendation 8886: "Information technology - Telecommunication and information exchange between systems - Data link service definitions for Open Systems interconnection".
- [21] ISO Recommendation 8509: "Information processing systems - Open Systems Interconnection - Service conventions".
- [22] ISO/IEC Recommendation 7809: "Information technology - Telecommunication and information exchange between systems - High-level data link control (HDLC) procedures - Classes of procedures".
- [23] ISO Recommendation 7776: "Information processing systems - High-level data link control procedures - Description of the X.25 LAPB-compatible DTE data link procedures".



## 2.1 Definitions and abbreviations

Abbreviations used in this specification are listed in GSM 01.04.

### Definitions:

**command:** An instruction represented in the RLP header, causing the receiving RLP entity to execute a specific function.

**frame check sequence:** A field of redundant information based on a cyclic code, used for error detection.

**I + S frame:** An RLP frame that is used for user information transfer, carrying supervisory information piggyback.

**improper frame:** An RLP frame having an FCS error or having a header the contents of which is inconsistent with this Specification.

**non-transparent:** In PLMN data transmission, a configuration where at layer 2, protocol information of the fixed network is mapped on RLP elements, and vice versa.

**piggybacking:** Means by which one and the same frame can carry both user information and RLP related supervisory information.

**response:** A reply represented in the RLP-header, by which the sending RLP entity reports back about its status.

**RLP frame:** A sequence of contiguous bits, representing an RLP procedural element.

**RLP header:** That part of an RLP frame that encodes either a command or a response, located at the beginning of the RLP frame.

**S frame:** An RLP frame that contains supervisory information in the absence of user information.

**transparent:** In PLMN data transmission, a configuration where at layer 2 (and also at the layers above) no protocol conversion takes place.

**U frame:** An RLP frame that contains unnumbered protocol control information.

## 3 Introduction

RLP makes use of an underlying FEC (Forward Error Correction) mechanism. For RLP to perform adequately it is assumed that the basic radio channel together with FEC provides for a block error rate of less than 10 %, where a block consists of 240 bits.

RLP frames are sent in strict alignment with the radio transmission. (For details, see GSM 04.21). RLP frames are of fixed size of 240 bits. Whenever such a 240 bit frame is to be sent, the RLP entity has to provide the necessary protocol information to be contained in it. Provision is made for discontinuous transmission (DTX).

RLP spans from the mobile station (MS) to the interworking function (IWF), located at the nearest mobile switching centre (MSC), or beyond. Depending on the exact location of the IWF, handover of the MS may result in link-reset or even total loss of the connection.

The MS shall initiate the RLP link. In addition the MSC/IWF may initiate the RLP link.

In the terminology of HDLC, RLP is used in a balanced configuration, employing asynchronous operation, i.e. either station has the right to set-up, reset, or disconnect a link at any time. Procedural means are provided for to deal with contentious situations, should they ever occur.

RLP is full-duplex in the sense that it allows for information to be transferred in both directions simultaneously.

## 4 Frame Structure

### 4.1 Basic frame structure

An RLP-frame has a fixed length of 240 bits consisting of a header (16 bits), an information field (200 bits), and an FCS (frame check sequence) field (24 bits). As a benefit of using strict alignment with underlying radio transmission there is no need for frame delimiters (like flags etc.) in RLP. In consequence, there is no "bit-stuffing" necessary in order to achieve code transparency. Frames cannot be aborted while being transmitted.

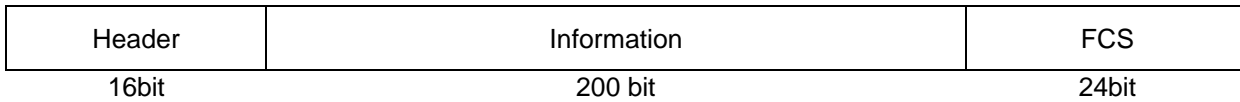

Figure 1: Frame structure

### 4.2 RLP header

An RLP-header carries one of three types of control information, the first being unnumbered protocol control information (U frames), the second being supervisory information (S frames), the third being user information carrying supervisory information piggybacked (I + S frames).

### 4.3 Order of transmission

The header, as defined in section 5.2, shall be transmitted from left to right. The FCS shall be transmitted commencing with the highest order term. The order of bit transmission for the information field is from left to right.

### 4.4 Frame check sequence

The FCS shall be the ones complement of the modulo 2 sum of

a) the remainder of

$$x^{216} (x^{23} + x^{22} + x^{21} + x^{20} + x^{19} + x^{18} + x^{17} + x^{16} + x^{15} + x^{14} + x^{13} + x^{12} + x^{11} + x^{10} + x^9 + x^8 + x^7 + x^6 + x^5 + x^4 + x^3 + x^2 + x + 1)$$

divided modulo 2 by the generator polynomial

$$x^{24} + x^{23} + x^{21} + x^{20} + x^{19} + x^{17} + x^{16} + x^{15} + x^{13} + x^8 + x^7 + x^5 + x^4 + x^2 + 1$$

and

b) the remainder of the division modulo 2 by the generator polynomial

$$x^{24} + x^{23} + x^{21} + x^{20} + x^{19} + x^{17} + x^{16} + x^{15} + x^{13} + x^8 + x^7 + x^5 + x^4 + x^2 + 1$$

of the product of  $x^{24}$  by the content of the frame, excluding the FCS field. (The first bit transmitted corresponds to the highest order term.)

Implementation note: As a typical implementation, at the transmitter, the initial content of the register of the device computing the remainder of the division is preset to all ones and is then modified by division by the generator polynomial (as described above) of the header and information field; the ones complement of the resulting remainder is transmitted as the 24 bit FCS sequence.

At the receiver, the initial content of the register of the device computing the remainder is preset to all ones. The final remainder after multiplication by  $x^{24}$  and then division (modulo 2) by the generator polynomial

$$x^{24} + x^{23} + x^{21} + x^{20} + x^{19} + x^{17} + x^{16} + x^{15} + x^{13} + x^8 + x^7 + x^5 + x^4 + x^2 + 1$$

of the serial incoming protected bits and the FCS will be

0 1 1 0 1 1 0 1 1 0 0 0 1 0 0 1 0 0 1 1 0 0 0 0 (x23 to x0, resp.)

in the absence of transmission errors.

## 5 Elements and procedure

### 5.1 Modes

An RLP entity can be in one of two modes:

- Asynchronous Balanced Mode (ABM)
- Asynchronous Disconnected Mode (ADM)

#### 5.1.1 Asynchronous Balanced Mode (ABM)

In ABM, which is the data link operational mode, either RLP entity may send commands at any time and may initiate response frame transmission without receiving explicit permission to do so from the other RLP-station. In ABM, frames shall be used for information field transfer and/or to indicate status changes in the RLP-station.

#### 5.1.2 Asynchronous Disconnected Mode (ADM)

In ADM, which is the data-link non-operational mode, the RLP entity shall be logically disconnected from the data link and shall, therefore, neither transmit nor accept numbered information frames.

The RLP entity shall, however, be permitted to transmit and accept NULL, DM, UI, TEST and XID frames. Either RLP entity can issue an SABM command at any time, in order to terminate the ADM state. In that case, entrance of the ABM state will be indicated by a UA response from the opposite station. If the opposite station is not able to enter ABM, it will indicate this by a DM response. All commands other than those mentioned above and any unsolicited response will be ignored in ADM under all circumstances.

### 5.2 Header and parameters

The formats defined for the header are listed in Figure 2 below.

#### 5.2.1 Generally used bits

NOTES: C/R = COMMAND/RESPONSE BIT  
 X = DON'T CARES  
 N(S) : Bit 4 low order bit  
 N(R) : Bit 11 low order bit

U	C/R	X	X	1	1	1	1	1	1	P/F	M1	M2	M3	M4	M5	X
S	C/R	S1	S2	0	1	1	1	1	1	P/F	N (R)					
I+S	C/R	S1	S2	N (S)						P/F	N (R)					
bit	1	2	3	4	5	6	7	8	9	10	11	12	13	14	15	16

S <sub>1</sub>	S <sub>2</sub>	
0	0	RR
0	1	REJ
1	0	RNR
1	1	SREJ

M <sub>1</sub> M <sub>2</sub> M <sub>3</sub> M <sub>4</sub> M <sub>5</sub>	
1 1 1 0 0	SABM
0 0 1 1 0	UA
0 0 0 1 0	DISC
1 1 0 0 0	DM
1 1 1 1 0	NULL
0 0 0 0 0	UI
1 1 1 0 1	XID
0 0 1 1 1	TEST

Figure 2 Header format

### 5.2.1.1 Command/response bit, C/R

The C/R-bit is used to indicate whether the frame is a command or response frame and whether the P/F-bit is to be interpreted as a poll or final bit, resp. For commands, the C/R bit shall be set to "1", for responses it shall be set to "0".

### 5.2.1.2 Poll/Final bit, P/F

The P/F-bit is used to mark a special instance of command/response exchange. With a command, it is called the P-bit, with a response, it is called the F-bit. In any one direction, only one P/F-bit exchange may be outstanding at any time. A response with the F-bit set to "1" shall always reflect the latest receive status of the RLP entity.

A P/F-bit exchange always starts with a command frame with the P-bit set to "1", which shall be answered by a response frame with the F-bit set to "1" at the earliest response opportunity.

No unsolicited F-bit = "1" is allowed. Such a frame shall be considered "improper" (see 5.3.1). In ABM, the use of the P/F-bit with numbered information exchange is only allowed for checkpoint-recovery (see 5.3.3).

## 5.2.2 Unnumbered frames, U

### 5.2.2.1 Set asynchronous balanced mode SABM (11100)

The SABM encoding is used as a command only. It is always used with the P-bit set to 1.

The SABM command is used either to initiate a link for numbered information transfer, i.e. to go from ADM to ABM, or to reset a link already established for numbered information transfer. With an SABM command, no information transfer is allowed.

When issuing an SABM, the RLP entity has set to zero its internal variables for sending and receiving numbered information. The other RLP entity, on receiving an SABM command, will either confirm it by setting to zero its internal variables for sending and receiving numbered information and then issuing an UA (unnumbered acknowledgement) response or reject it by sending a DM (disconnected mode) response. In the former case, both entities have entered ABM and numbered information transfer may commence. In the latter case, both entities are in ADM.

When an SABM command is issued, a loss of information may occur. Appropriate action is in the responsibility of the layers above.

#### **5.2.2.2 Unnumbered Acknowledge, UA (00110)**

The UA encoding is used as a response only. It is used to positively acknowledge an SABM or DISC command. With the UA response, no information transfer is allowed.

#### **5.2.2.3 Disconnect, DISC (00010)**

The DISC encoding is used as a command only. It is used to disestablish a link, previously established for numbered information transfer, i.e. to terminate ABM and go into ADM. With the DISC command, no information transfer is allowed.

The other RLP-entity shall answer with a UA response before actioning the DISC command. When a DISC command is actioned, loss of information may occur. It is the responsibility of the layers above, to provide for a "graceful" disconnect.

#### **5.2.2.4 Disconnected Mode, DM (11000)**

The DM encoding is used as a response only. It is used by RLP entity to report that it is in ADM and, as an answer to SABM, that it is unable to action a mode setting command. With the DM response, no information transfer is allowed.

#### **5.2.2.5 Unnumbered Information, UI (00000)**

The information field is to be interpreted as unnumbered information. Unnumbered information (UI) frames can be sent in both ADM and ABM. There is no acknowledgement of receipt of UI-frames within RLP.

#### **5.2.2.6 Exchange Identification, XID (11101)**

The information field is to be interpreted as exchange identification. This frame is used to negotiate and renegotiate parameters of RLP and layer 2 Relay function. XID frames can be sent in both ADM and ABM.

The negotiation procedure is one step i.e. one side will start the process by sending an XID command, offering a certain set of parameters from the applicable parameter repertoire (see table 1) the sending entity wants to negotiate proposing values within the allowed range. In return, the other side will send an XID response, either confirming these parameter values by returning the requested values, or offering higher or lower ones in their place (see Table 1 for sense of negotiation), except when the indicated RLP version is a lower one where a limited set of those parameters presented in the XID command may be answered according to the negotiated version. This normally will end the negotiation process. XID frames are always used with the P/F-bit set to "1".

Without any prior XID exchange, default values will apply (see section 5.4).

In the case of a collision of XID commands, all XID commands shall be ignored. The Mobile Station shall restart the parameter negotiation on expiry of T1, while the Interworking Function shall do so on expiry of twice the value of T1. An unsuccessful XID exchange shall be repeated on expiry of T1. After N2 times of unsuccessful repetition, the link shall be disconnected.

In the following, a list of parameters is given which constitute the parameter repertoire for this RLP version. In addition, the format of the XID information field is given.

Parameter Name	Type	Length	Range (octets)	Units	Sense of Negotiation
RLP version N°*	1	1	0..255	./.	down
IWF to MS window size	2	1	0..61	./.	down
MS to IWF window size	3	1	0..61	./.	down
Acknowledgement timer(T1)	4	1	0..255	10ms	up
Retransmission attempts (N2)	5	1	0..255	./.	up
Reply delay (T2)**	6	1	0..255	10ms	up

\* Note 1: The current version of RLP is "0". This is also the default value for the version N°. It is assumed that future versions of RLP will be backwards-compatible with former ones.

\*\* Note 2: In case of negotiation of this parameter it may be necessary to negotiate also the "Acknowledgement timer" (T1).

**Table 1   XID parameters**

The type and length are encoded within one octet, the type field occupying bits 8 to 5 and the length field occupying bits 4 to 1; 1 resp. 5 being the least significant bit. The least significant bit shall always be transmitted first.

A parameter item consists of the type/length-octet followed by the value of that parameter, where the length-indicator gives the number of octets the value actually occupies. Such parameter items may be arranged in arbitrary order, but must begin in the first octet of the XID-information field and follow on contiguously. The parameter list is delimited by parameter type zero.

#### **5.2.2.7 Test, TEST (00111)**

The information field of that frame is to be interpreted as test information. Test frames can be sent in both ADM and ABM. A test sequence is always initiated by sending a TEST command in one direction and completed by sending a TEST response in the other direction.

#### **5.2.2.8 Null information, NULL (11110)**

In ADM, null-frames shall be sent each time there is a send opportunity but no UI, TEST or XID frame is awaiting transmission.

In ABM, null-frames shall be sent in reset state if there is a send opportunity and no unnumbered frames are to be sent.

The information field is to be interpreted as null information i.e. the information field is not used and its contents may be arbitrary.

#### **5.2.3 Supervisory frames, S, and numbered information transfer and supervisory frames combined, I+S**

In ABM, there are cases where there is no user information pending transmission. In consequence, supervisory (S) frames alone must be conveyed. In such cases, the information field is to be interpreted as null information, i.e. the information field is not used and may be of arbitrary contents.

For reasons of optimization in the special situation of digital radio transmission, numbered information transfer frames carry also supervisory type information ("piggy-backing"). Numbered information can be exchanged only in ABM.

NOTE: The extent to which piggy-backing is used by the sending RLP entity is optional. An RLP entity receiving any of allowed piggy-backed formats, however, shall take the appropriate actions. Implementors should be aware that not using the full capability of piggy-backing could, in certain circumstances, result in a less than optimal performance.

##### **5.2.3.1 Send Sequence number, N(S)**

The sequence number contains the number of the I frame. As far as N(S) is concerned, modulus 62 arithmetic is applied for frame numbering, thus allowing for a maximum window size of 61. On mutual agreement between the communicating parties, a smaller window size may be established. With the exception of SREJ conditions, information frames are transmitted in numerical order of their N(S). Normal information transfer is halted, when the number of outstanding, unacknowledged frames is equal to the currently established window size.

##### **5.2.3.2 Receive sequence number, N(R)**

The N(R) field is used in ABM to designate the next information frame to be sent by the other RLP entity and to confirm that all frames up to and including N(R) - 1 have been received properly. As an exception to this, in the case of SREJ (selective reject), N(R) designates the information frame that is selectively rejected and thus requested for retransmission. In this case, no previously received frames are confirmed.

N(R) provides for a modulus of 62, thereby allowing for a maximum window size of 61, i.e. a maximum of 61 information frames may be outstanding at any time.

### 5.2.3.3 Receive ready, RR (00)

The RR encoding can be used either as command or response. In ABM, it is used by an RLP entity to confirm all information frames up to and including N(R)-1. In doing so, the RLP-station allows the other station to transmit up to k additional information frames, counting from N(R) onwards. The issue of an RR command/response clears any previous busy condition in that direction.

### 5.2.3.4 Reject, REJ (01)

The REJ encoding can be used either as command or response. It is used by an RLP entity to indicate that in numbered information transfer one or more out-of sequence frames have been received. Frames up to and including N(R)-1 have been received correctly, frames N(R) and following are requested to be retransmitted. Following retransmission of those frames, further frames awaiting initial transmission may be sent. With respect to each direction of transmission, only one REJ condition may exist at any given time.

A REJ condition is cleared on

- receipt of the frame numbered N(R)
- on time-out
- or on reset (SABM)

An REJ shall be sent at the earliest opportunity. On time-out, REJ frames shall not be repeated. An RLP-entity receiving an REJ frame with the same N(R), which has already been the starting frame of a retransmission sequence due to P/F-bit checkpointing, shall inhibit the retransmission due to that particular REJ frame.

### 5.2.3.5 Receive not ready, RNR (10)

The RNR encoding can be used either as command or response. It is used by an RLP entity to indicate that it is temporarily not ready to receive numbered information frames. In that case, the RLP entity is said to be in the busy condition. All frames up to and including N(R)-1 shall be considered acknowledged. Subsequent frames, if any, shall not be considered confirmed. The acceptance status of those is a matter of further status exchange.

### 5.2.3.6 Selective reject, SREJ (11)

The SREJ encoding can be used either as command or response. The SREJ command/response is used to request retransmission of a single frame, thus, under certain circumstances, providing for more efficient error recovery than by REJ. No acknowledgement of received I frames is indicated by an SREJ frame, thus allowing an RLP entity to transmit one or more SREJ frames with a different N(R) before earlier SREJ conditions have been cleared.

An SREJ condition shall be cleared

- on receipt of an information frame with N(S) equal N(R) of the SREJ
- on time out
- on reset (SABM)

No SREJ shall be issued during a pending REJ condition. For each frame, only one SREJ condition may exist at any time.

SREJ frames shall be sent at the earliest possibility. On time-out, SREJ frames may be repeated.

NOTE: Sending SREJ commands/responses is not mandatory.



### 5.3 Error Recovery

#### 5.3.1 Improper frames

Frames containing an FCS error or having a control field the contents of which is not implemented or inconsistent with those defined in this Specification are called improper frames. Improper frames shall be ignored, i.e. the receiving RLP station shall not make any use of their contents.

#### 5.3.2 N(S) sequence error

In numbered information transfer, any information frame with an N(S) out of the normal sequence shall lead to an N(S) sequence error condition, unless that frame is requested for retransmission by an SREJ, sent at an earlier time. There are three mechanisms to deal with N(S) sequence errors.

- REJ recovery
- SREJ recovery
- P/F-bit recovery (checkpointing),

the first two being the responsibility of the receiving station, the last being the responsibility of the sending station. There are no strict rules as to whether REJ or SREJ recovery shall be applied, however, if a station decides to initiate REJ or SREJ recovery, it shall do so at the earliest opportunity. The information part of out-of sequence frames shall be discarded, unless the receiving station intends to initiate SREJ recovery.

#### 5.3.3 Time-out and checkpointing

All frames requiring a response or acknowledgement shall be guarded by time-out. (Timer T1) In detail, those frames are those containing

- SABM
- DISC
- REJ
- SREJ
- numbered information (see note)
- any frame with the P-bit set to "one" in ABM, i.e. checkpointing

NOTE: T1 started, or restarted if already running, on the transmission of every numbered information frame.

##### 5.3.3.1 Treatment of errors during link establishment, link reset and link disconnect

An SABM, which is not answered by either UA or DM within the timer period, shall be repeated up to N2 times. A DISC, which is not answered by UA within the timer period, shall be repeated up to N2 times.

If the SABM or DISC, respectively, is finally unanswered, the RLP station will go into ADM in any case. For this reason, it is the responsibility of the management of any RLP entity to put the RLP entity into ADM, should there be an indication of a permanent outage, i.e. a loss of connectivity longer than N2 times the timer value.

### 5.3.3.2 Treatment of errors during numbered information transfer

The last frame of a sequence of numbered information frames shall also be guarded by time-out. If neither a positive acknowledgement nor a REJ is received, the RLP entity will start checkpoint recovery, i.e. the station will send a frame with the P-bit set to "1", requesting the latest status information from the other entity, indicated by the F-bit set to "1". In that case, status information is carried either by RR or RNR responses and all frames currently held by the responding RLP entity which are not delivered because of missing frames shall be discarded. A P-bit set to "1" shall only be sent with a Supervisory Frame.

Awaiting the latest status information from the other RLP entity, the sending entity does not react on REJ and SREJ frames received during this time. If such status information is received, retransmission from N(R) onwards will be performed if appropriate. However, no frame sequence starting with a given N(R) shall be retransmitted more than N2 times. If there is a frame sequence that cannot be transmitted successfully after N2 repetitions, the RLP link shall be reset or disconnected.

If no status information is received during the time-out period, this request will be repeated up to N2 times. If still there is no valid status reported back, the RLP link shall be reset or disconnected.

### 5.3.4 Contentious situations

Due to the asynchronous procedure, various contentious situations may arise. A contention of SABMs shall result into both entities be set into ABM or be reset. A contention of DISC's shall result into both entities be disconnected. A contention of SABM and DISC shall result into both entities be disconnected.

## 5.4 List of system parameters

The system parameters are as follows:

### 5.4.1 Timer T1

The period of Timer T1 is regarded to start at the beginning of the transmission of the relevant frame.

The negotiation (or default) value is defined to be the earliest instant to enter recovery.

The period of Timer T1 at the end of which retransmission of a frame may be initiated according to the procedures described in 5.3 above, is a system parameter agreed for a period of time.

The proper operation of the procedure requires that Timer T1 be greater than the maximum time between transmission of frames (SABM, DM, DISC, I or supervisory commands) and the reception of the corresponding frame returned as a response to this frame (UA, DM or acknowledging frame). Therefore, the RLP entity should not delay the response or acknowledging frame returned to the above frame by more than a value T2. T2 is a system parameter, which is less than T1.

### 5.4.2 Maximum number of retransmissions N2

The value of the maximum number of retransmissions N2 of a frame following the running out of Timer T1 is a system parameter agreed for a period of time.

### 5.4.3 Maximum number of outstanding I frames k

The maximum number (k) of sequentially numbered I frames that may be outstanding (i.e. unacknowledged) at any given time is a system parameter which can never exceed 61. It shall be agreed for a period of time.

Name	Range of values	Default and recommended value
k MS > IWF	0 - 61	61
k IWF > MS	0 - 61	61
T1	> 380 ms > 440 ms > 600 ms	480 ms (fullrate on 12 kbit/s) 540 ms (fullrate on 6 kbit/s) 780 ms (halfrate)
T2		<80 ms (fullrate on 12 kbit/s) <80 ms (fullrate on 6 kbit/s) <80 ms (halfrate)
N2	> 0	6

$T2 < T1 - (2 * \text{transmission delay})$

**Table 2 RLP parameter values**

### 5.5 Support for discontinuous transmission (DTX)

In both ADM and ABM, whenever the RLP entity has no numbered or unnumbered supervisory commands/responses and no information transfer frames pending transmission, the RLP entity shall indicate to the lower layer that the DTX function may be invoked.

NOTE: In case DTX is invoked, in ADM a NULL-frame will be sent, and in ABM an RR or RNR S-frame will be sent.

## 6 Service Definitions

### 6.1 Introduction

This chapter defines the service provided by the RLP-sublayer to the L2R-sublayer at the boundary between the RLP-sublayer and the L2R-sublayer.

The relationships between RLP-sublayer, L2R-sublayer and RLP-protocol are shown in figure 3.

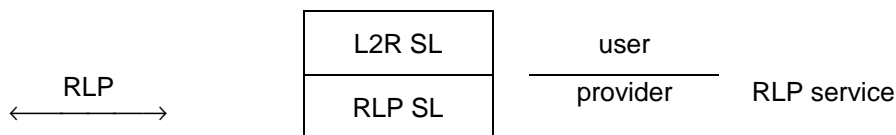

**Figure 3 Basic relationship between RLP and L2R**

The RLP service is defined in terms of

- the primitive actions and events of the service.
- the parameters associated with each primitive action and event.
- the inter-relationship between, and the valid sequence of, these actions and events.

### 6.2 Conventions

For the description of the Data Link Service, the following conventions are used with time-sequence diagrams:

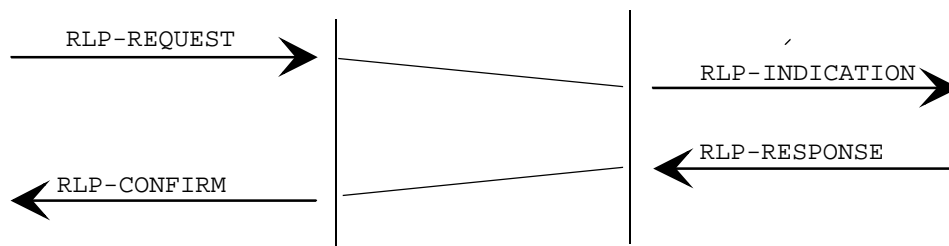

**Figure 4 Confirmed service with acknowledgement**

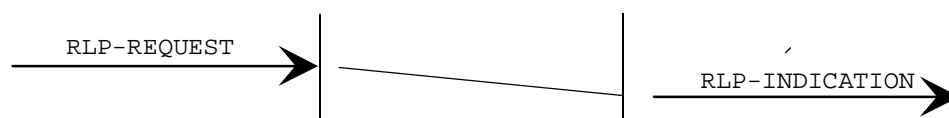
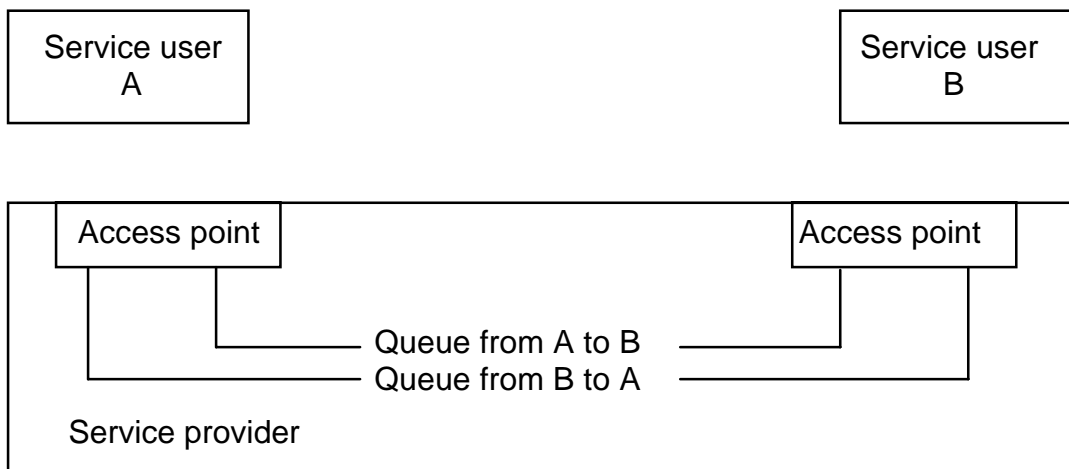

**Figure 5 Unconfirmed service**

In time-sequence diagrams, time moves from top to bottom. Arrows indicate the flow of information. Such flow of information may be subject to implicit flow-control. Skewed lines indicate a logical relationship between arrows. For clarity, the absence of such a relation may be marked by the symbol "~" (tilde).

### 6.3 Queue Model

Between the two endpoints of an RLP-connection, there exists a flow control function. As a means of specifying this flow control feature and its relationship with other capabilities of the RLP, the following queue model is provided.



**Figure 6 Queue Model**

The following objects may be placed in a queue by a service user:

- a) connect
- b) connection-mode data (numbered information)
- c) reset
- d) disconnect

The following objects may be placed in a queue by a service provider:

- a) reset
- b) synchronization mark
- c) disconnect

NOTE: Other possible objects (i.e. unnumbered information, identification, test) are irrelevant (-) to the queue model and for reasons of simplicity are not shown.

The relation between these objects is shown in the following table:

Preceding	Following	Connect	Data	Reset	Sync Mark	Disconnect
Connect		NA	----	-----	NA	DES
Data		NA	----	DES	NA	DES
Reset		NA	----	DES	----	DES
Synchronization Mark		NA	----	DES	NA	DES
Disconnect		NA	NA	NA	NA	DES

Legend:

NA : Not applicable

-- : not destructive, not able to advance ahead of the preceding object

DES : Destructive to the preceding object

## 6.4 List of Primitives

Link establishment

RLP-CONNECT-REQUEST  
 RLP-CONNECT-INDICATION  
 RLP-CONNECT-RESPONSE (-NEG)  
 RLP-CONNECT-CONFIRM (-NEG)

Normal Data Transfer

RLP-DATA-REQUEST (INF)  
 RLP-DATA-INDICATION (INF)

Reset

RLP-RESET-REQUEST  
 RLP-RESET-INDICATION  
 RLP-RESET-RESPONSE  
 RLP-RESET-CONFIRM

Release

RLP-DISCONNECT-REQUEST  
 RLP-DISCONNECT-INDICATION

Miscellaneous

unnumbered information

RLP-UNITDATA-REQUEST (INF)  
 RLP-UNITDATA-INDICATION (INF)

Exchange Identification

RLP-XIDDATA-REQUEST (INF)  
 RLP-XIDDATA-INDICATION (INF)

Test

RLP-TESTDATA-REQUEST (INF)  
 RLP-TESTDATA-CONFIRM (-NEG) (INF)

**6.5 Possible RLP time sequence diagrams**

a) Connection establishment (without collision)

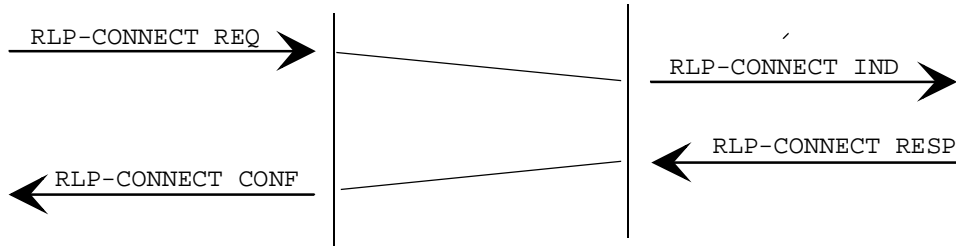

b) Connection establishment (with collision)

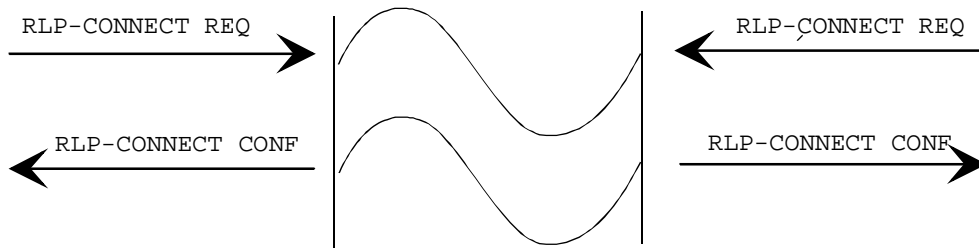

c) User invoked release (without collision)



d) Collision of user invoked releases

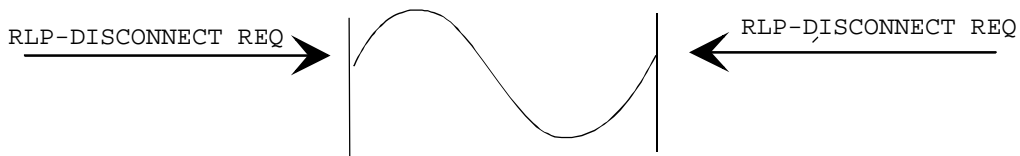

e) Simultaneous user and provider invoked release

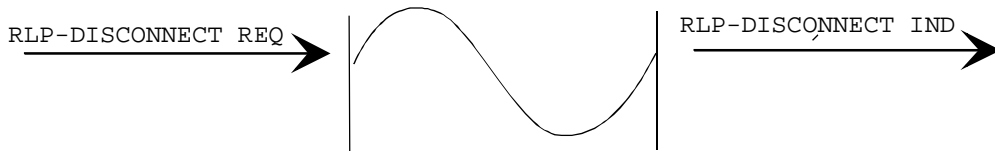

f) Provider invoked release

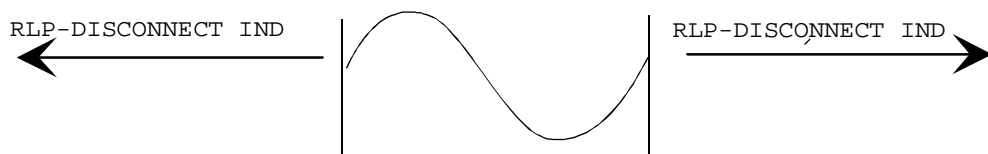

g) Provider rejection of establishment

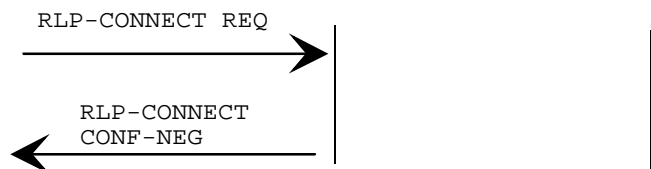

h) Normal data transfer



i) User invoked reset



j) Collision of user invoked resets

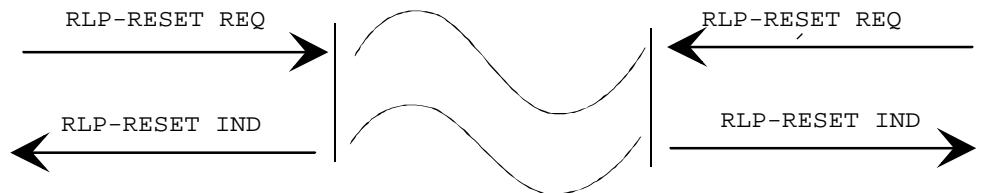

k) provider invoked reset

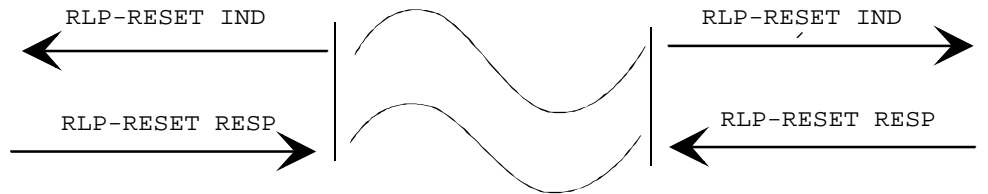

l) simultaneous user and provider invoked reset





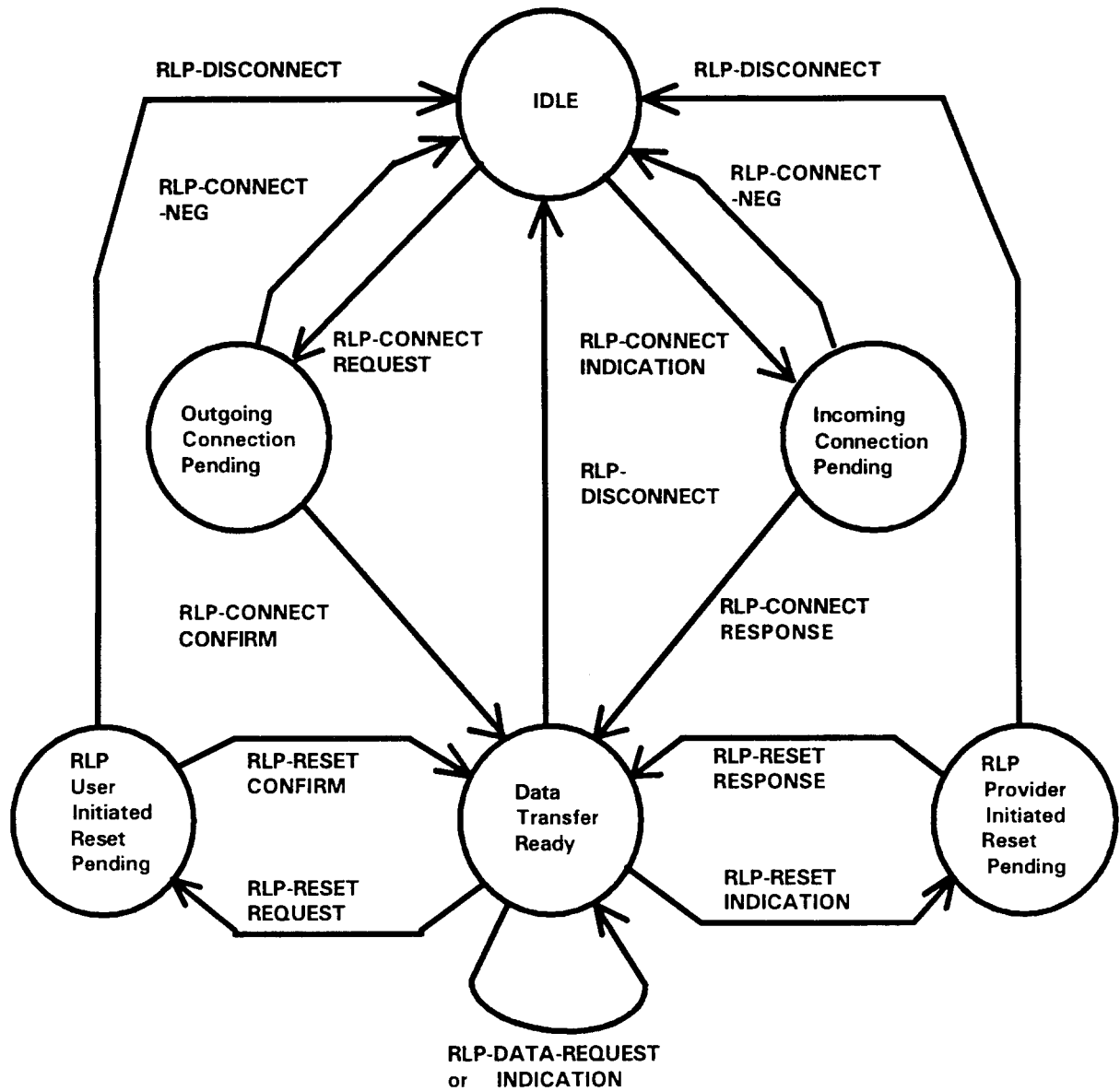

Figure 7 State transition diagram for sequence of RLP connection-mode service primitives

## Annex A (Informative): RLP SDL Diagrams

This annex describes a model implementation of an RLP entity.

The description should help to clarify GSM Specification 04.22, the RLP service and protocol definition.

However, it is not intended to restrict any implementation of an RLP entity in any way, on condition the implementation shows the correct behaviour at the RLP protocol level.

The model implementation consists of three processes. Process "SEND\_PDU" adds the CRC to a given PDU and hands it to the lower layer entity for transmission. Process "RECEIVE\_PDU" gets a received PDU block, checks the value of the CRC and the bits of the PDU header. If the CRC has the right value and if the header is syntactically correct, the receipt event is signalled to the "RLP\_KERNEL" process, which is the protocol handling automaton.

Each process is described as an extended finite state machine (using SDL-Diagrams).

Each state of the automaton is described by a (main-)state number and a corresponding (main-)state name. The state may further be distinguished by the value of other state variables. This scheme is used because not every state variable needs to be defined in every state. The states are defined in chapter A.1.

The RLP machine reacts on events, which may be classified as

- lower layer interface events
- upper layer interface events
- and
- station management or internal events

The events of the RLP-Kernel are described in section A.2.

## A.1 List of RLP entity states

### A.1.1 (main) states

state number	state symbol	state name
0	S0	ADM and Detached
1	S1	ADM and Attached
2	S2	Pending Connect Request
3	S3	Pending Connect Indication
4	S4	ABM and Connection Established
5	S5	Disconnect Initiated
6	S6	Pending Reset Request
7	S7	Pending Reset Indication

### A.1.2 state variables

The main states are further distinguished by the values of the state variables.

However, not every state variable is used (evaluated/ defined) in every state.

First some constants need to be defined:

M = 62	number of different sequence numbers (modulus)
Nmin = 0	smallest sequence number
Nmax = 61	largest sequence number (= M - 1)
N2 = 6	maximum number of retransmissions

variable name	variable type and range	semantic
Ackn_FBit	(0, 1)	Value of the F-Bit used in the next acknowledging PDU.
Ackn_State	(idle, send)	Ackn_State = send means, an acknowledging PDU (Supervisory or Data) has to be sent.
C	(0, 1)	to store the C/R-Bit value of a received S- or I-frames
Data	char[25]	to store temporarily the information part (user data) of a received I-frame.
DISC_Count	(0, 1,..., N2)	to count the transmissions of DISC.
DISC_PBit	(0, 1)	The value of the P-bit in the next DISC command PDU.
DISC_State	(idle,send,wait)	if (DISC_State = send) the DISC command PDU has to be sent at the next possible opportunity.  if (DISC_State = wait) the RLP entity waits for the corresponding response.
DM_FBit	(0, 1)	Value of the F-Bit used in the next DM response PDU.
DM_State	(idle, send)	if (DM_State = send) the PDU DM has to be sent.

DTX_SF	(N, RR, RNR)	to store the last Supervisory frame for DTX (only RR or RNR can be suppressed)
DTX_VR	(0, 1,..., Nmax)	to store the last transmitted value of VR (used to decide the DTX condition)
F	(0, 1)	to store temporarily the F-bit of a received response PDU.
NR	(0, 1,..., Nmax)	to store temporarily the receive sequence number of a received S- or I-frame.
NS	(0, 1,..., Nmax)	to store temporarily the send sequence number of a received I-frame.
P	(0, 1)	to store temporarily the P-bit of a received command PDU
P_F	(0, 1)	to store temporarily the P- or F-bit of received command or response PDUs.
Poll_Count	(0, 1,..., N2)	to count the transmissions of poll requests.
Poll_State	(idle,send,wait)	(Poll_State = send) means, a supervisory PDU with P-bit set to one has to be sent.  (Poll_State = wait) means, the RLP entity waits for the response with F-bit set to one.
Poll_xchg	(idle, wait)	(Poll_xchg = idle) means, sending of a frame with P-bit set is allowed.  (Poll_xchg = wait) means, an acknowledgement of a previous P-bit is outstanding.
R[M]	record array	Receiver slots (M slots, numbered 0 to M-1)
R[n].Data	char[25]	to store user information
R[n].State	(idle, rcvd, ackn, srej, wait)	(R[n].State = rcvd) means, data has been received (with sequence number n). (R[n].State = ackn) means, data has been received and acknowledged.  (R[n].State = srej) means, the retransmission of data has to be requested using srej(n).  (R[n].State = wait) means, the entity waits for the requested retransmitted data.
REJ_State	(idle, send, wait)	The REJ_State is send if and only if a REJ PDU has to be sent.
returncode	Integer	used in procedures to report a result
RRReady	Boolean	Remote Receiver Ready
SABM_Count	(0, 1,..., N2)	to count the transmissions of SABM.
SABM_State	(idle, send, wait)	if (...State = send) the SABM PDU has to be sent.

		if (.._State = wait) the RLP entity waits for the UA response.
S[M]	record array	Sender Slots (M slots, numbered 0 to M-1)
S[n].Data	char[25]	user information to be sent.
S[n].State	(idle, send, wait)	(S[n].State = send) means, data has to be sent (with sequence# n).
SF	(RR,RNR,REJ,SREJ)	to store the last superv. PDU type
T	Timer	used by the data sender if waiting for I-frame acknowledgements or F-bits.
TEST_Count	(0, 1,...,N2)	to count the transmissions of TEST.
TEST_C_Data	char [25]	data to be sent in the next TEST command PDU.
TEST_C_PBit	(0, 1)	value of the P-Bit used in the next TEST command PDU.
TEST_C_State	(idle, send, wait)	if (.._State = send) the TEST command PDU has to be sent.
		if (.._State = wait) the RLP entity waits for the next TEST reponse.
TEST_R_Data	char[25]	data to be sent in the next TEST response PDU.
TEST_R_FBit	(0, 1)	value of the P-Bit used in the next TEST response PDU.
TEST_R_State	(idle, send)	if (.._State = send) the TEST response PDU has to be sent.
T_RCVR	Timer	used by the receiver to timeout a REJ condition.
T_RCVS(n)	Timer	used by the receiver to timeout a SREJ condition for Slot n.
T_TEST	Timer	used by the sender of a TEST frame if waiting for a TEST response.
T_XID	Timer	used by the sender of a XID frame if waiting for the XID response.
UA_FBit	(0, 1)	value of the F-Bit used in the next UA response.
UA_State	(idle, send)	if (UA_State = send) an UA PDU has to be sent.
UI_Data	char[25]	data to be sent in the next UI PDU.
UI_PBit	(0, 1)	value of the P-Bit used in the next UI PDU.
UI_State	(idle, send)	if (UI_State = send) a UI PDU has to be sent.
VA	(0, 1,..., Nmax)	frame sequence number of oldest not yet acknowledged I-frame (if VA = VS then there are no unacknowledged frames).

VD	(0, 1, ..., Nmax)	slot number used in the next Data_Req.
VR	(0, 1, ..., Nmax)	receiver sequence number (the next received I-frame is expected to carry this sequence number).
VS	(0, 1, ..., Nmax)	sender sequence number (under normal operating conditions the next I-frame is assigned this number).
XID_Count	(0, 1,...,N2)	to count the transmissions of XID commands.
XID_C_Data	char [25]	data to be sent in the next XID command PDU.
XID_C_PBit	(0, 1)	value of the P-Bit used in the next XID command PDU.
XID_C_State	(idle, send, wait)	if (.._State = send) the XID command PDU has to be sent.  if (.._State = wait) the RLP entity waits for the next XID reponse.
XID_R_FBit	(0, 1)	value of the P-Bit used in the next XID response PDU.
XID_R_State	(idle, send)	if (.._State = send) the XID response PDU has to be sent.

## A.2 List of RLP entity events

The interface is indicated by l:lower, u:upper and m:management. From the formal definition point of view this distinction of course is unnecessary.

event#	name	semantic	interface
1	Attach_Req	Switch to "ADM and Attached"	m
2	Conn_Ind	Connect indication	u
3	Conn_Conf	Connect confirm	u
4	Conn_Conf_Neg	Connect confirm negative	u
5	Conn_Req	Connect request	u
6	Conn_Resp	Connect response	u
7	Conn_Resp_Neg	Connect response negative	u
8	Data_Ind(Date)	Data transfer indication (user data in data)	u
9	Data_Req(Data)	Data transfer request (user data in data)	u
10	Detach_Req	Switch to "ADM and Detached"	m
11	Disc_Ind	Disconnection indication	u
12	Disc_Req	Disconnect request	u
13	DISC(P)	PDU DISC received (P-bit in P)	l
14	DM(F)	PDU DM received (F-bit in F)	l
15	Error_Ind	Error Indication	u
16	LL_Data_Req	Data request to lower layer	l
17	LL_Data_Ind	Data indication from lower layer	l
18	NULL	PDU NULL received	l
19	Ready_Ind	Indication that a new PDU may be sent	m
20	Reset_Conf	Reset confirm	u
21	Reset_Ind	Reset indication	u
22	Reset_Req	Reset request	u
23	Reset_Resp	Reset response	u
24	RR_I(C,P_F,NR,NS,Data)	I-frame RR received	l
25	RNR_I(C,P_F,NR,NS,Data)	I-frame RNR received	l
26	REJ_I(C,P_F,NR,NS,Data)	I-frame REJ received	l
27	SREJ_I(C,P_F,NR,NS,Data)	I-frame SREJ received	l
28	RR(C,P_F,NR)	S-frame RR received	l
29	RNR(C,P_F,NR)	S-frame RNR received	l
30	REJ(C,P_F,NR)	S-frame REJ received	l
31	SREJ(C,P_F,NR)	S-frame SREJ received	l
32	SABM(P)	PDU SABM received	l
33	UA(F)	PDU UA received (F-bit in F)	l
34	UI_Req(Data)	Unnumbered Information transfer request	u
35	UI(C,P_F,Data)	UI PDU received	l
36	T	Timeout (Timer of the sender expired)	m
37	Test_Conf(Data)	Test confirm (received data in Data)	u
38	Test_Conf_Neg(Data)	Test confirm negative (received data in Data)	u
39	T_RCVR	Timeout (Timer of the receiver for REJ exp.)	m
40	T_RCVS(n)	Timeout (Timer of the receiver for SREJ ep.)	m
41	T_TEST	Timeout (Test timer expired)	m
42	T_XID	Timeout (Xid timer expired)	m
43	Test_Req(Data)	Test request (Test data in Data)	m
44	TEST(C,P_F,Data)	TEST command/response PDU received (C/R-bit in C, P/F-bit in P_F, Data in Data)	l
45	XID_Req(Data)	Exchange ID request	m
46	XID_Ind(Data)	Exchange ID indication	m
47	XID(C,P_F,Data)	XID command/response PDU received	l

## SYSTEM RLP - OVERVIEW

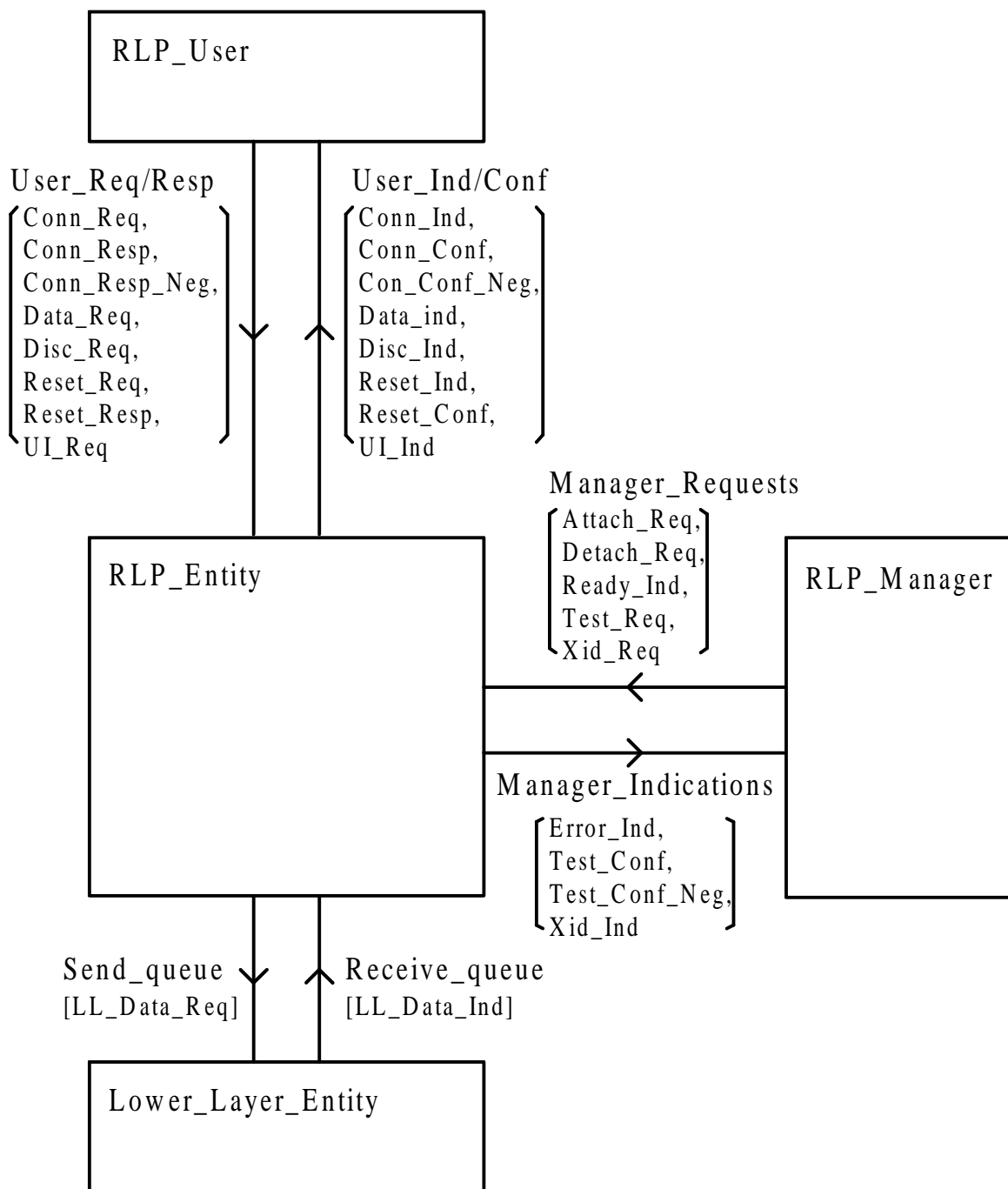

04.22 Annex A, Figure 01



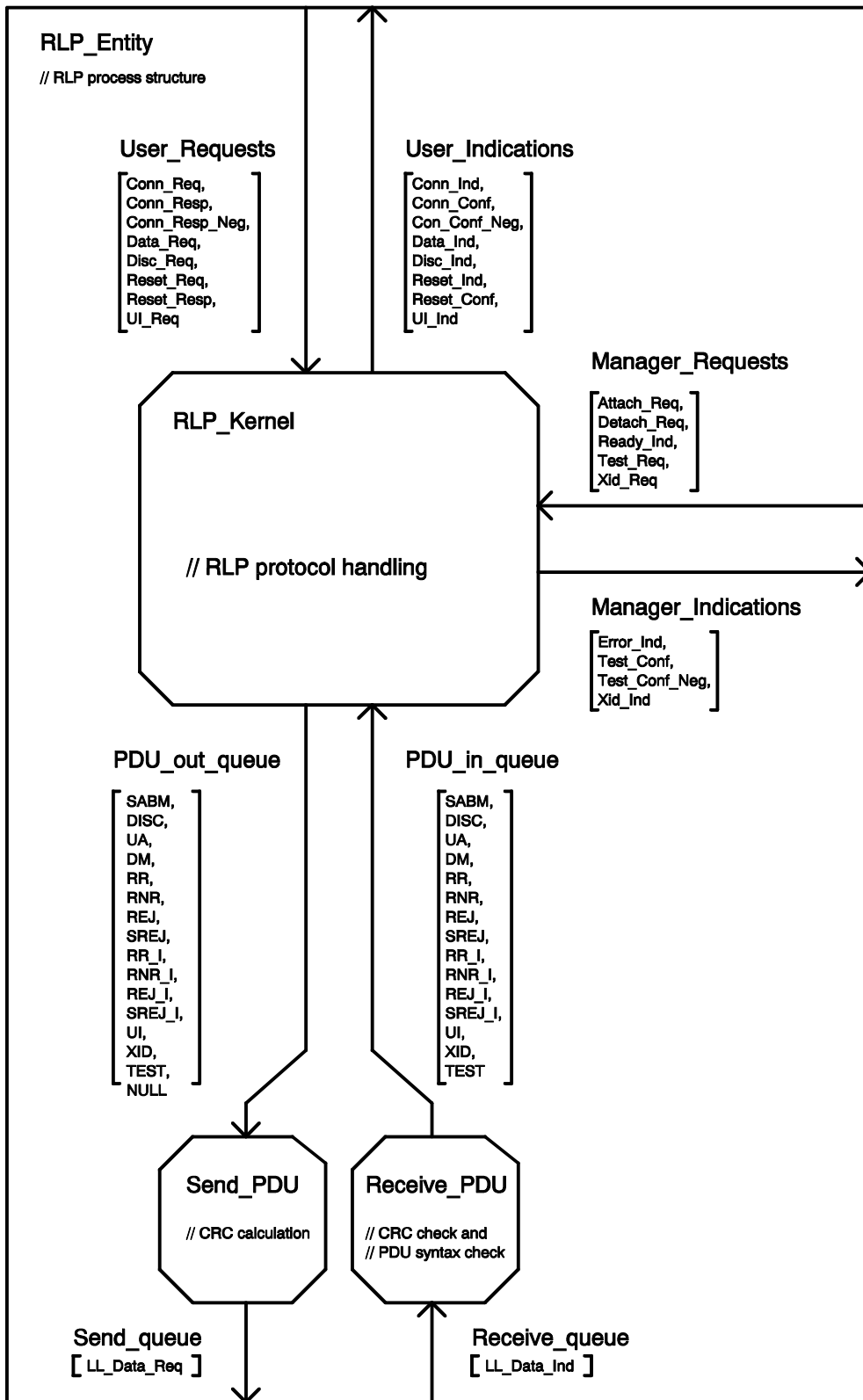

04.22 Annex A, Figure 02

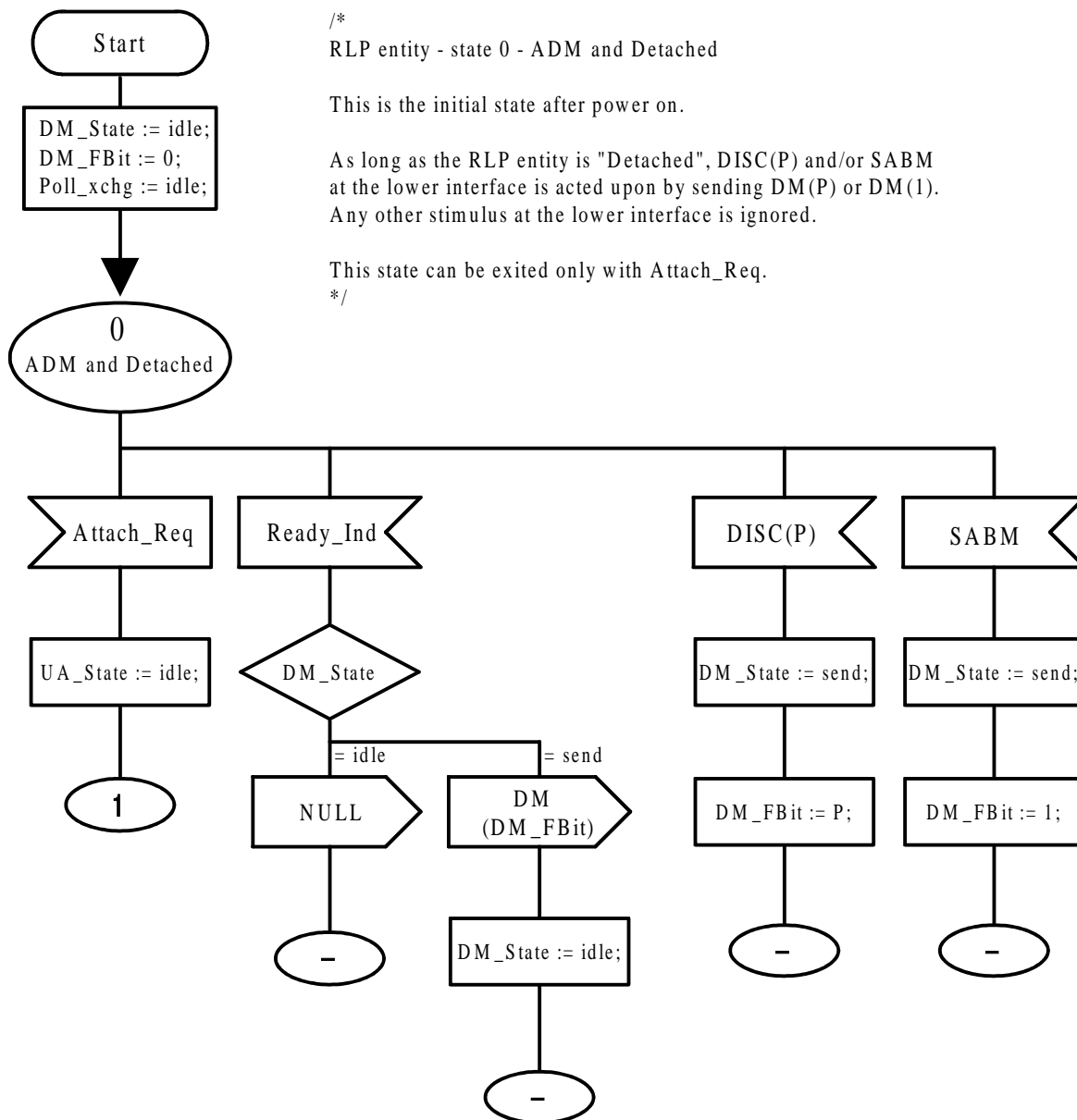

04.22 Annex A, Figure 03

/\*  
 RLP entity - state 1 - ADM and Attached

The RLP entity is ready to establish a connection, either by initiating the connection itself (Conn\_Req) or by responding to an incoming connection request (SABM).

Upon receiving a DISC PDU, the sending of the UA response is initiated.  
 \*/

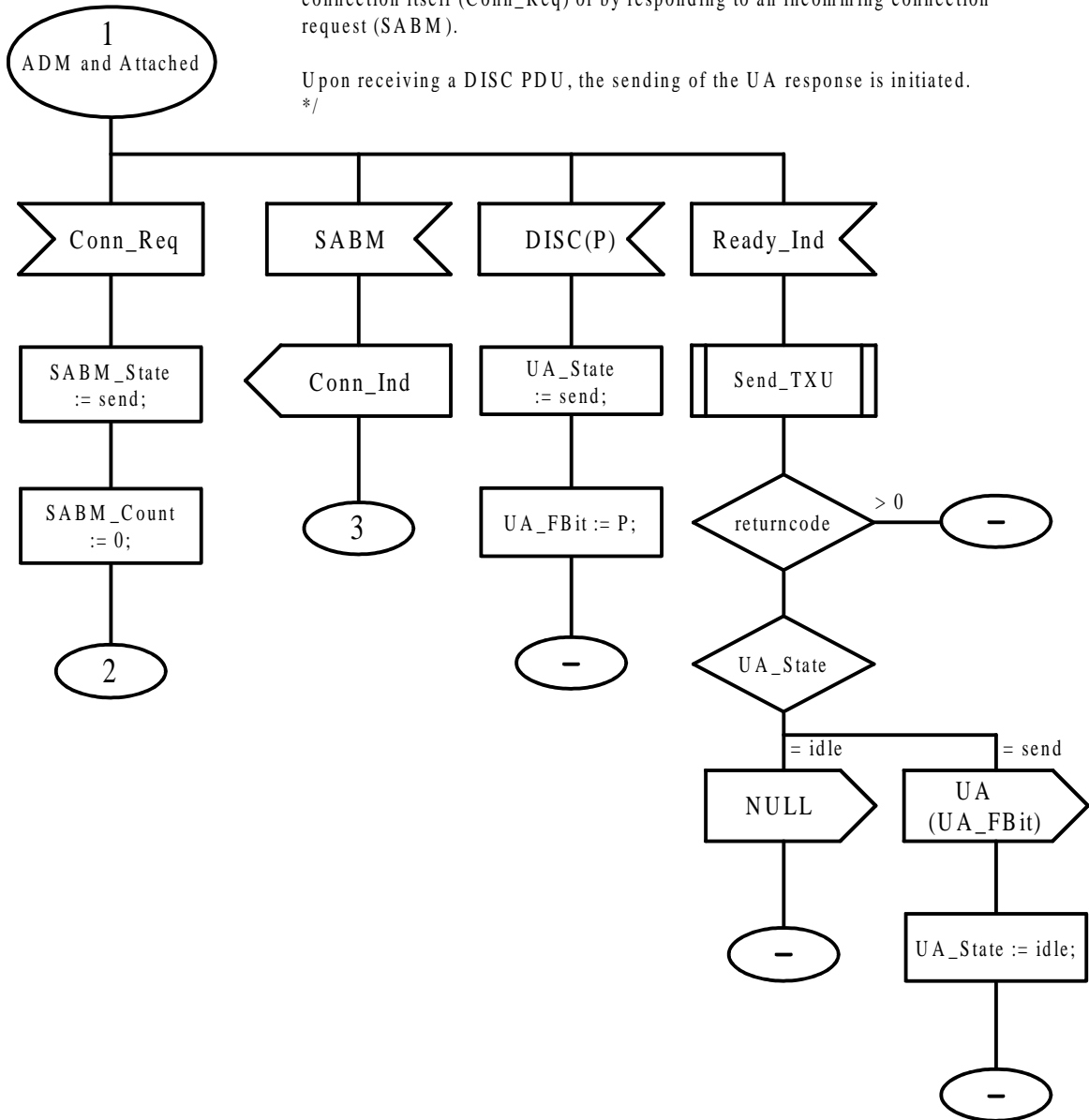

04.22 Annex A, Figure 04

/\*  
 RLP entity - state 2 - Pending connect request

Send (up to N2 repetitions) SABM and wait for the corresponding  
 UA with FBit = 1.

The (sub)state is controlled by the variable SABM\_State  
 (values idle, send, wait) and SABM\_Count (values 0, 1, ..., N2).

This state may be exited with a Disconnect Request (see figure 14).

\*/

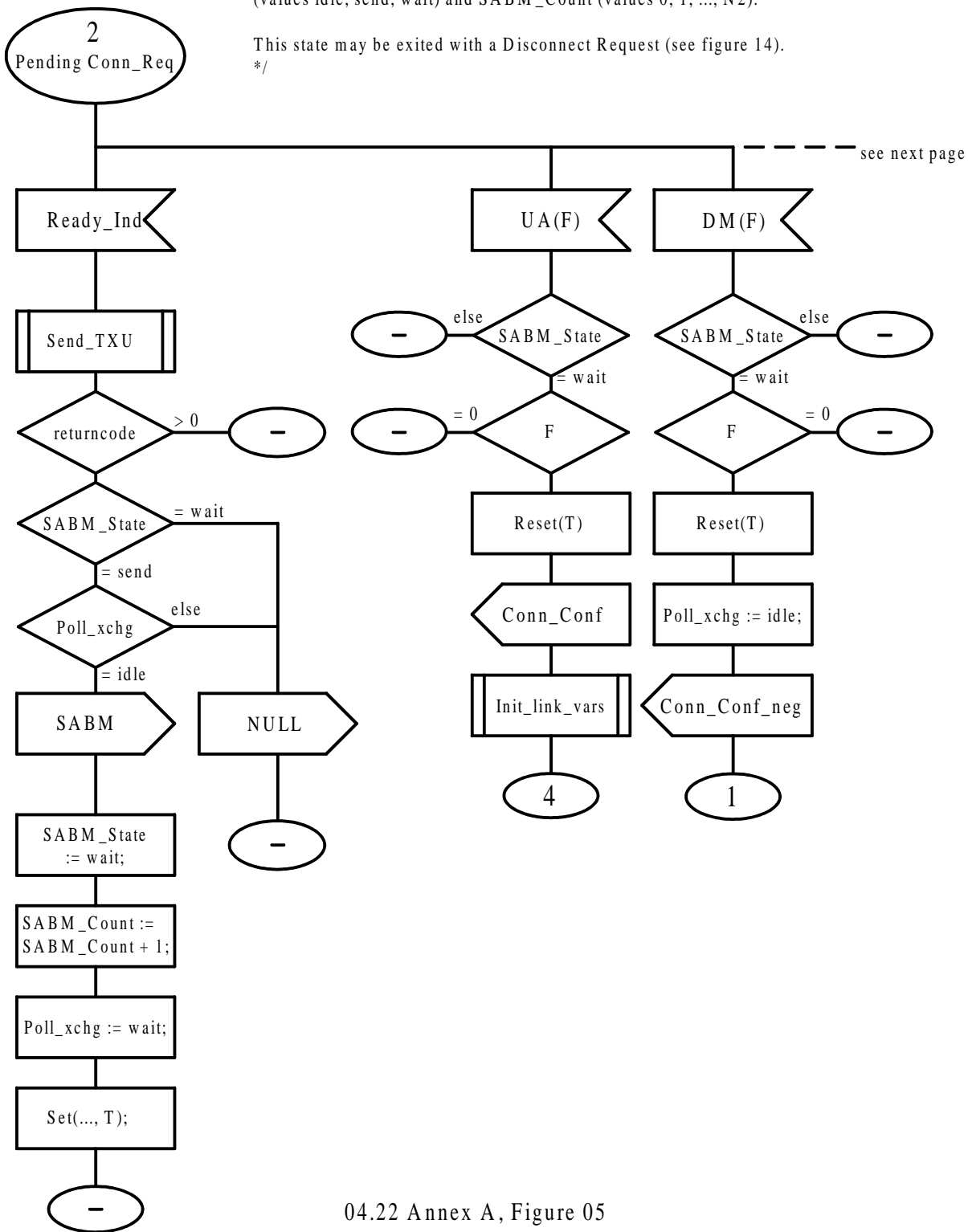

04.22 Annex A, Figure 05

/\*  
 RLP entity - state 2 - Pending connect request

This figure allows up to N2 repetitions of SABM and describes the disconnect and the SABM contention case.  
 \*/

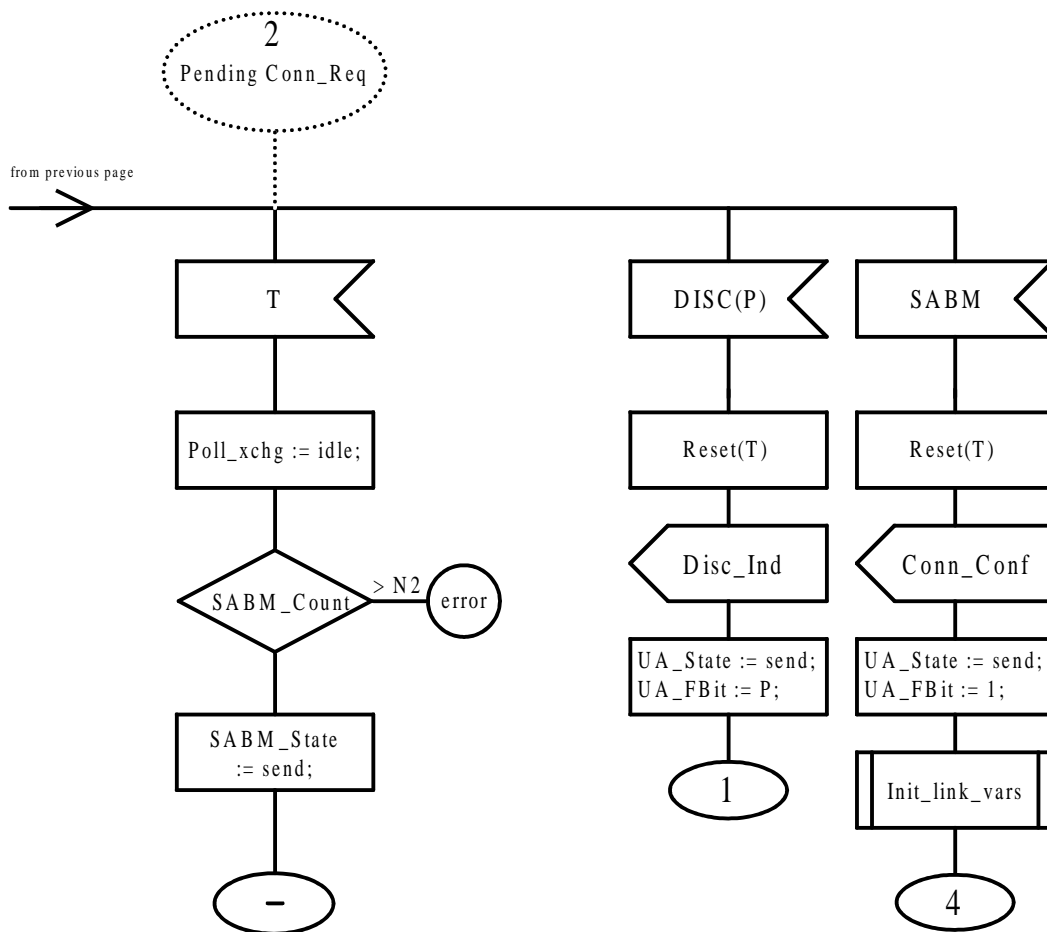

04.22 Annex A, Figure 06

/\*  
 RLP entity - state 3 - pending Connect indication  
 After having received SABM, the RLP entity is waiting for the Connect response.

The upper layer entity may respond with Conn\_Resp or Disc\_Req. It is assumed that the upper layer entity does not delay the response more than T2 msecs.

The Disconnect request exit is described on a following page (see figure 14).  
 \*/

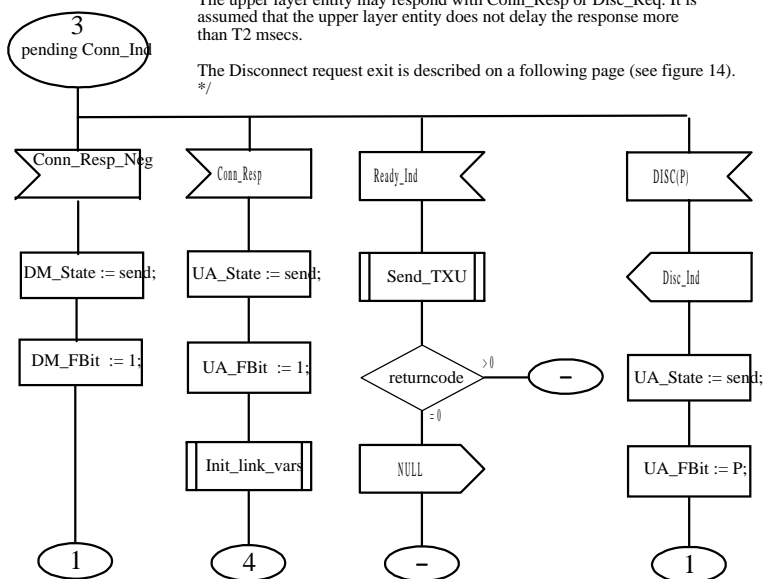

04.22 Annex A, Figure 07

/\*  
 RLP entity - state 4 - Connection established

This is the data transfer state. The user entity may transmit data by firing Data\_Requests. However, he is allowed to do so only if there are idle sender slots.

The data stored in the send slots will be transmitted at the next possible opportunity.

This state may be exited by a Disconnect Request (see Figure 14).

\*/

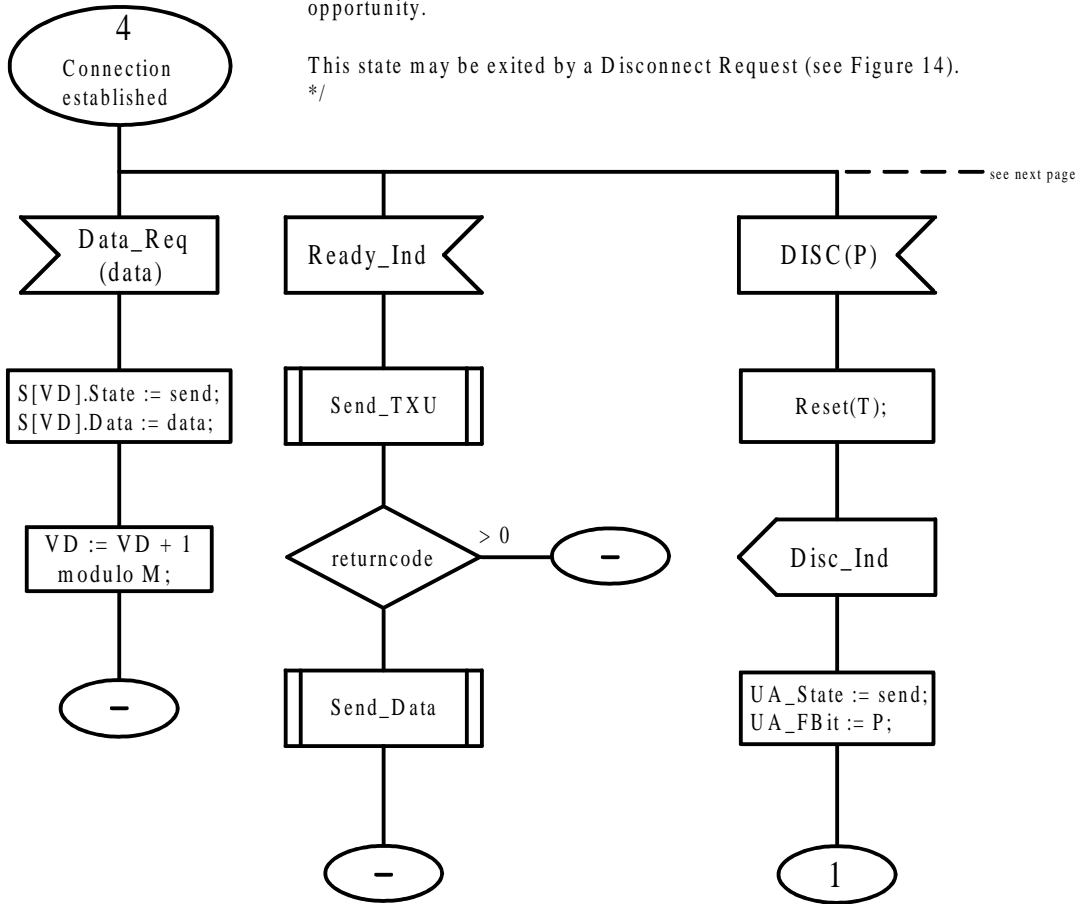

04.22 Annex A, Figure 08

/\*  
 RLP entity - state 4 - Connection established

This diagram describes RESET and the Timeout-handling.

A timeout leads to error recovery by polling. This is controlled by the Poll\_State variable. The Poll\_State transitions are:

idle -> send <-> wait -> idle

Zero up to N2 transitions wait->send may occur.

\*/

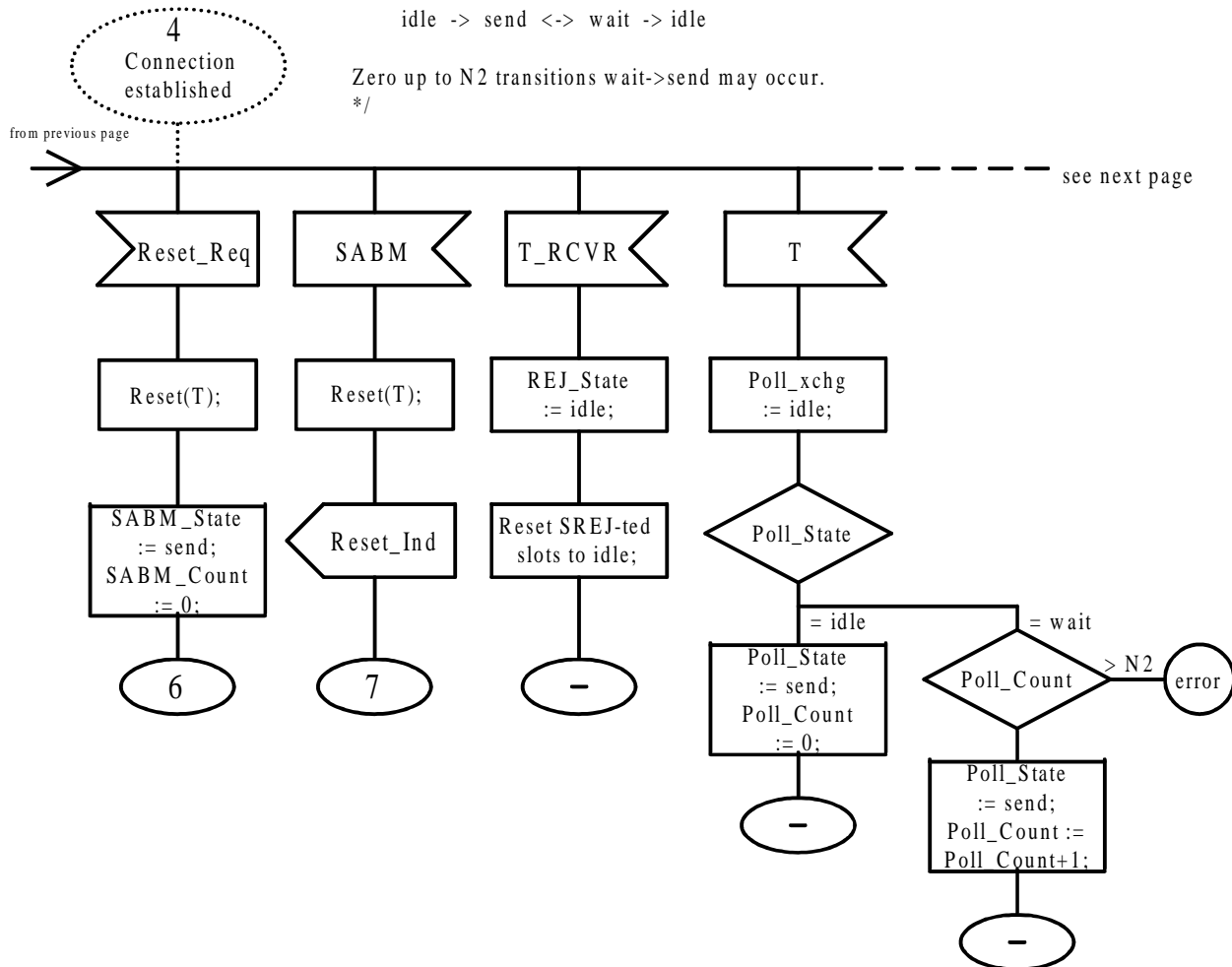

04.22 Annex A, Figure 09



/\*  
RLP entity - state 4 - Connection established

This diagram describes the handling of I-frames and S-frames  
(PDUs RR, RNR, REJ, SREJ and RR\_I, RNR\_I, REJ\_I, SREJ\_I).

If the frame contains user information, this is handled by the I-Handler.  
The supervisory information is handled by the S-handler.

A frame with an unsolicited F-bit is ignored.  
\*/

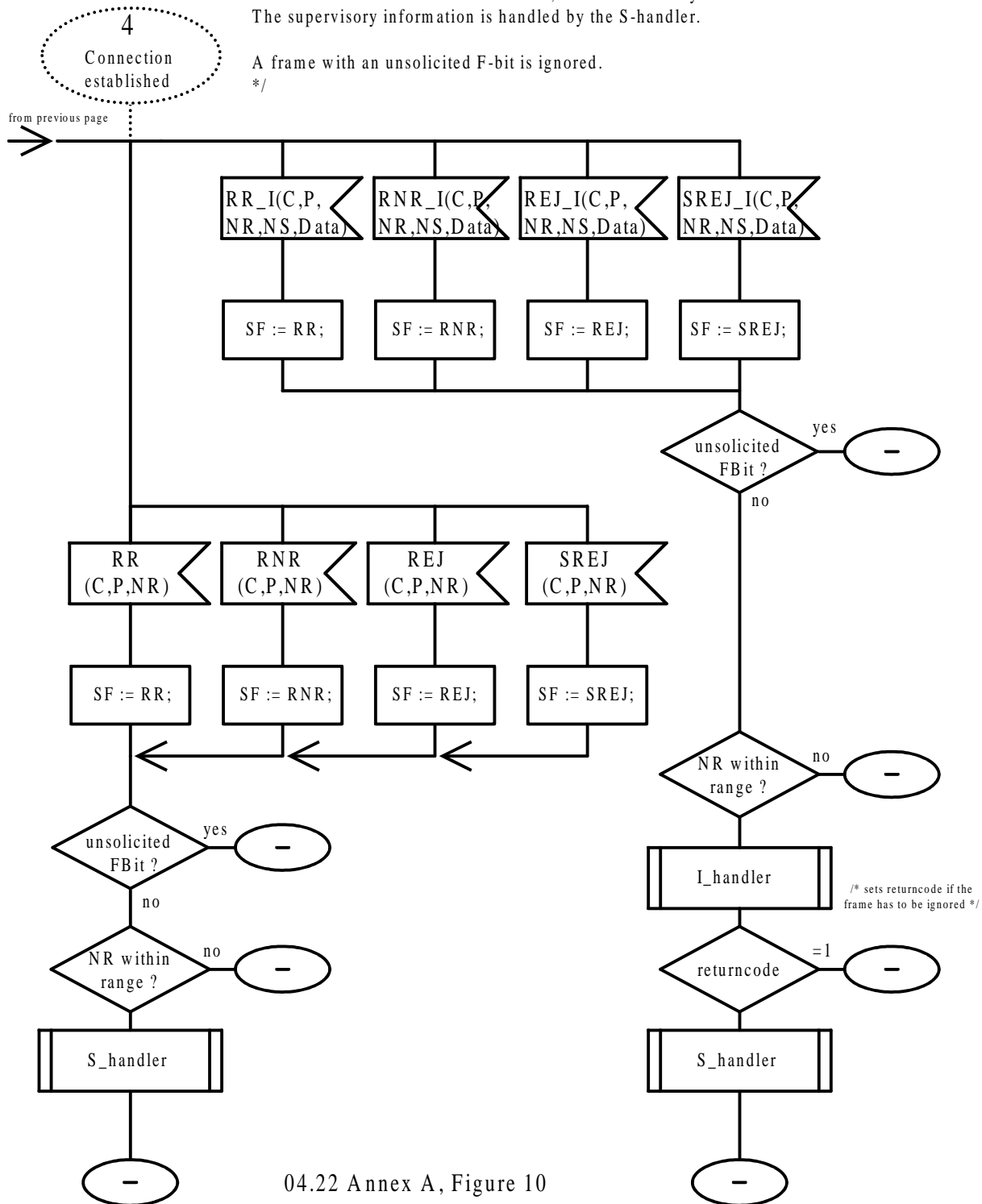

04.22 Annex A, Figure 10

/\*  
 RLP entity - state 5 - Disconnect initiated

This state is exited only after a valid response is received  
 or after N2 timeouts.  
 \*/

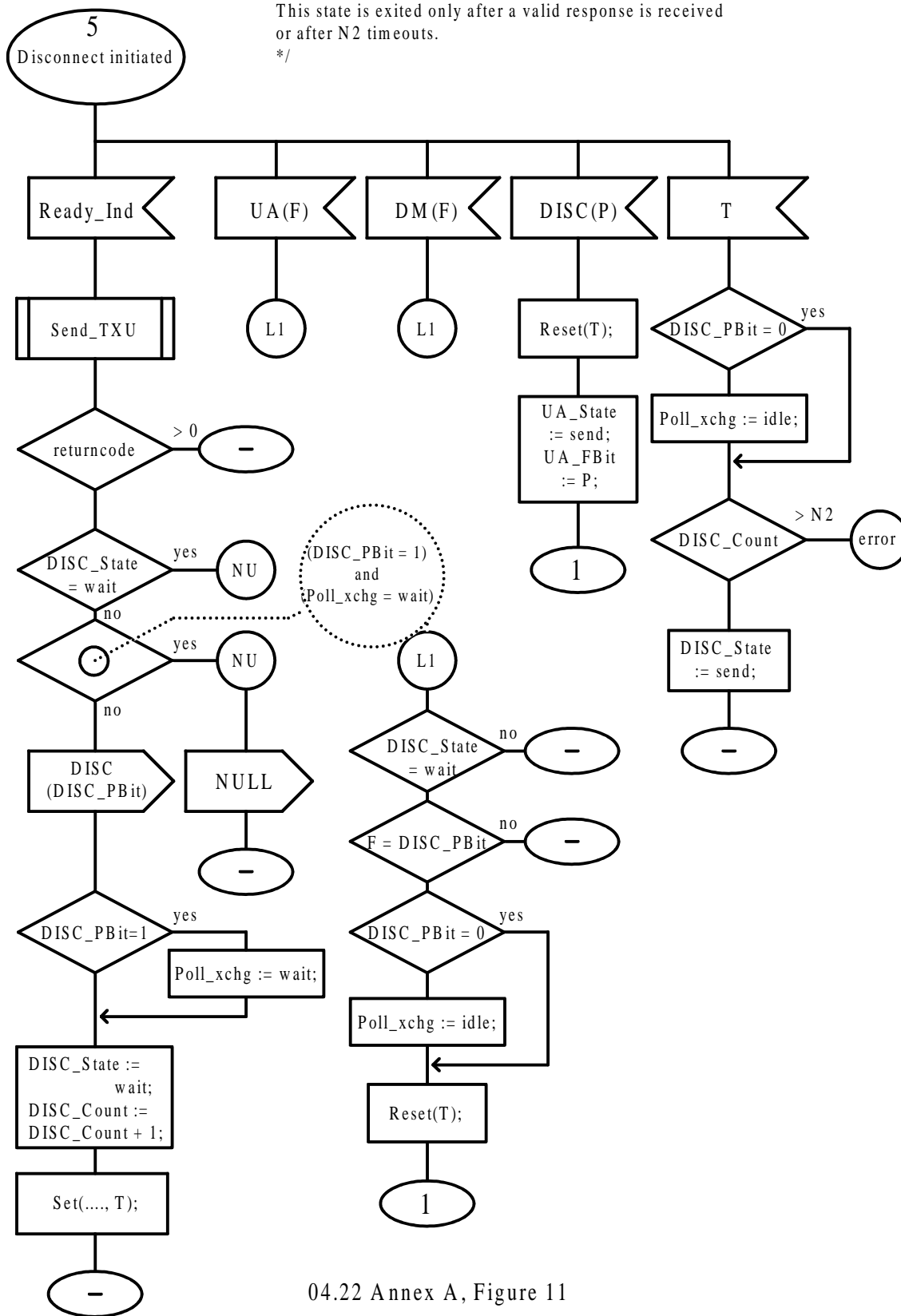

04.22 Annex A, Figure 11

/\*  
RLP entity - state 6 - pending Reset Request

Send (up to N2 repetitions) SABM and wait for the responding UA with FBit=1.

The substate is controlled by the variable SABM\_State (values idle, send, wait) and SABM\_Count (values 0..N2).

This state may be exited with a Disconnect Request (see Figure 14).

\*/

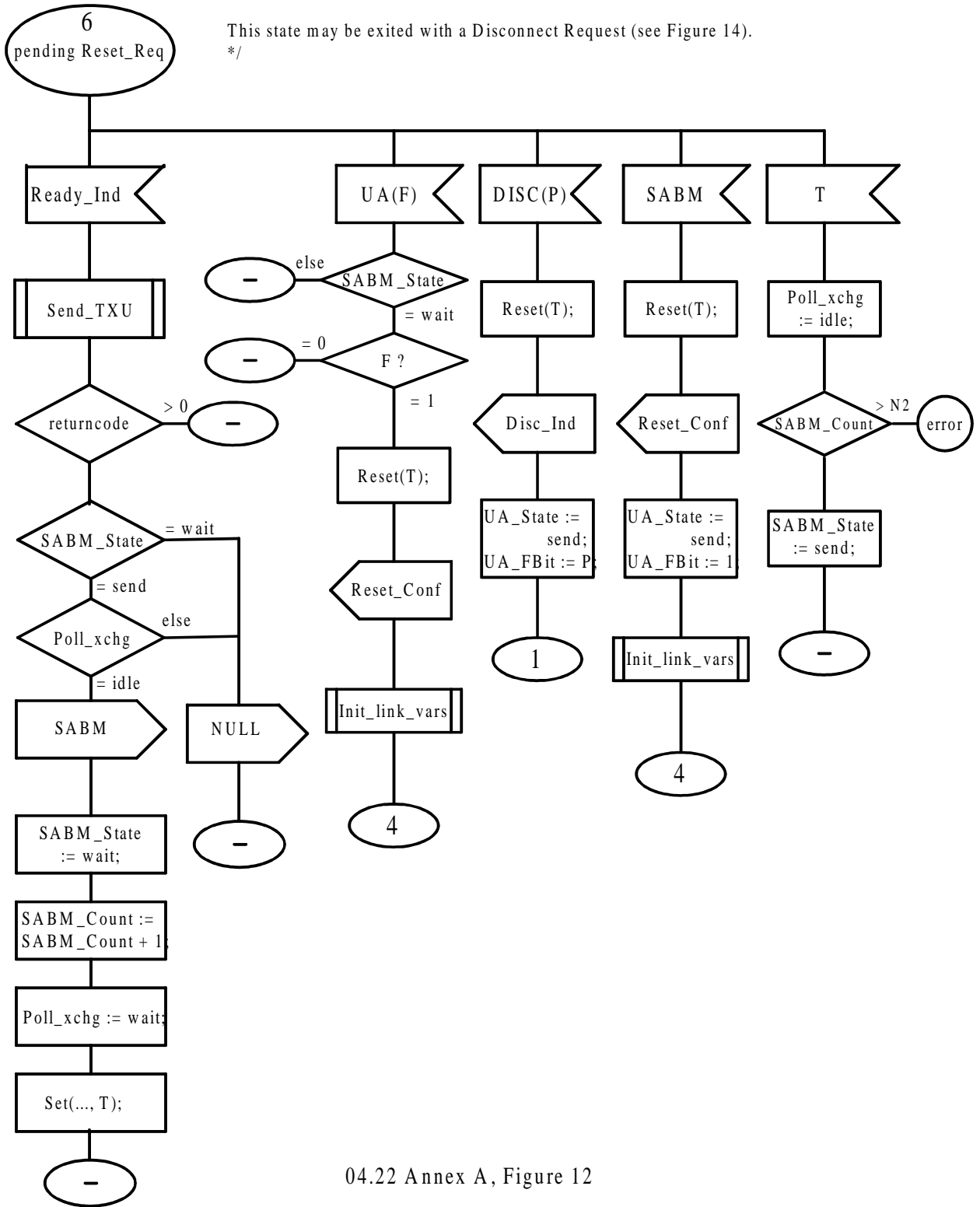

04.22 Annex A, Figure 12

/\*  
 RLP entity - state 7 - pending Reset Indication

After having received SABM and having indicated Reset, the RLP entity is waiting for the Reset\_Response.

The upper layer entity may respond with Reset\_Resp or Disc\_Req. It is assumed, that the upper layer entity does not delay the response more than T2 msec.

The Disconnect Request is described on a following page (see Figure 14).  
 \*/

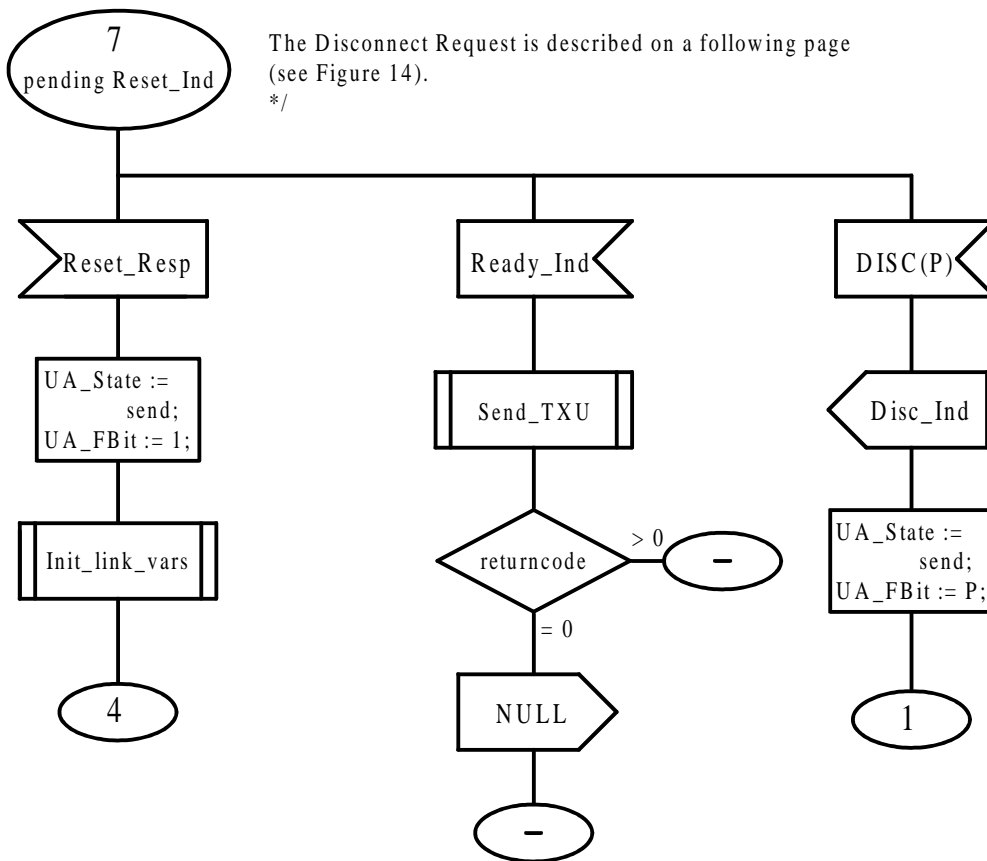

04.22 Annex A, Figure 13

/\*  
 This is the error handling  
 when there is no action  
 from the remote end  
 after N2 repetitions.  
 The error handling  
 and the state transition  
 depends on the situation  
 e.g. ADM in case of DISC  
 \*/

/\*  
 Detach Request  
  
 Detach is allowed at  
 any time.  
  
 The Detach Request  
 is used to reset the RLP  
 entity to state 0, e.g. if  
 the physical connection  
 is lost.  
 \*/

/\*  
 Disconnect Request  
  
 Disconnect is used to release a connection.  
  
 The actions to be executed in these cases are:  
 reset the timer, activate sending of the DISC PDU.  
  
 The P-bit in the DISC command is set to  
 one or zero, depending on the Poll\_xchg state.  
 \*/

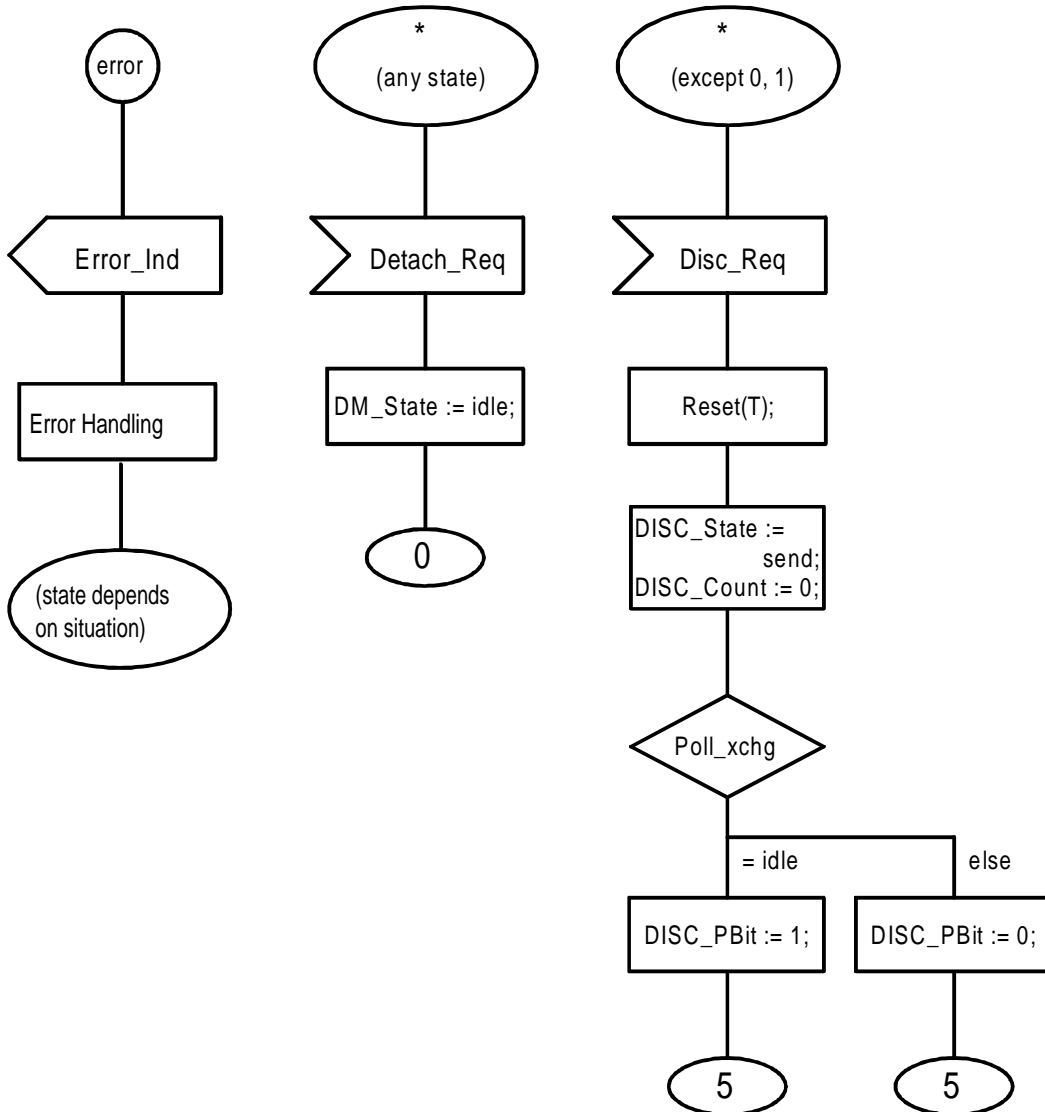

0422AF14.DRW 93-02-25

04.22 Annex A, Figure 14

/\*  
 UI handling (UI\_Req, UI)

UI\_Requests are controlled using the state variable UI\_State. The values (state transitions) are: idle -> send -> idle

It is assumed that the upper layer entity issues an UI\_Req only if the RLP entity's UI\_State is idle. The UI data is stored in the variable UI\_Data.

The UI\_PDU is generated at the next possible opportunity, i.e. after the higher priviledged PDUs (TEST PDUs, XID PDUs, if any) have been transmitted.

\*/

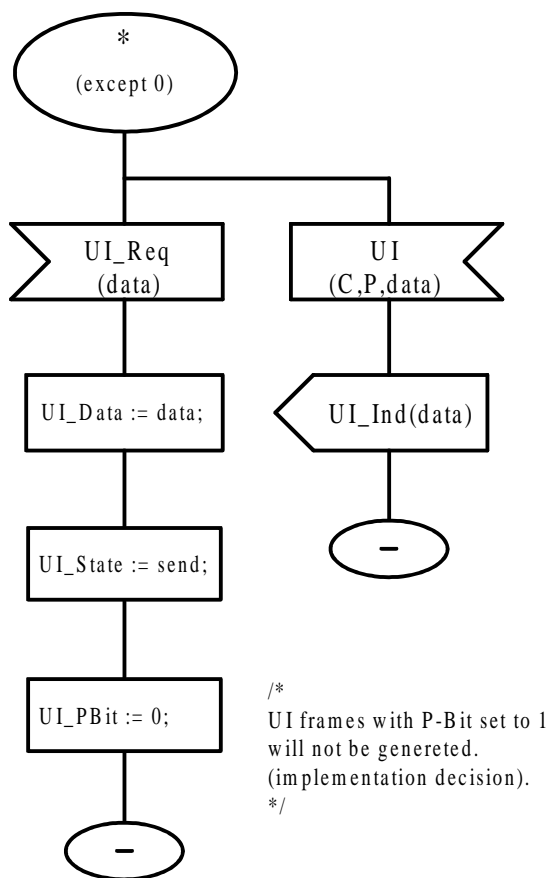

04.22 Annex A, Figure 15

/\*  
XID handling (XID\_Req, XID)

XID requests are controlled using the state variable XID\_C\_State and XID\_R\_State. The state transitions being used are:

idle -> send -> wait -> idle.

The XID data is stored in the variable XID\_C\_Data.

\*/

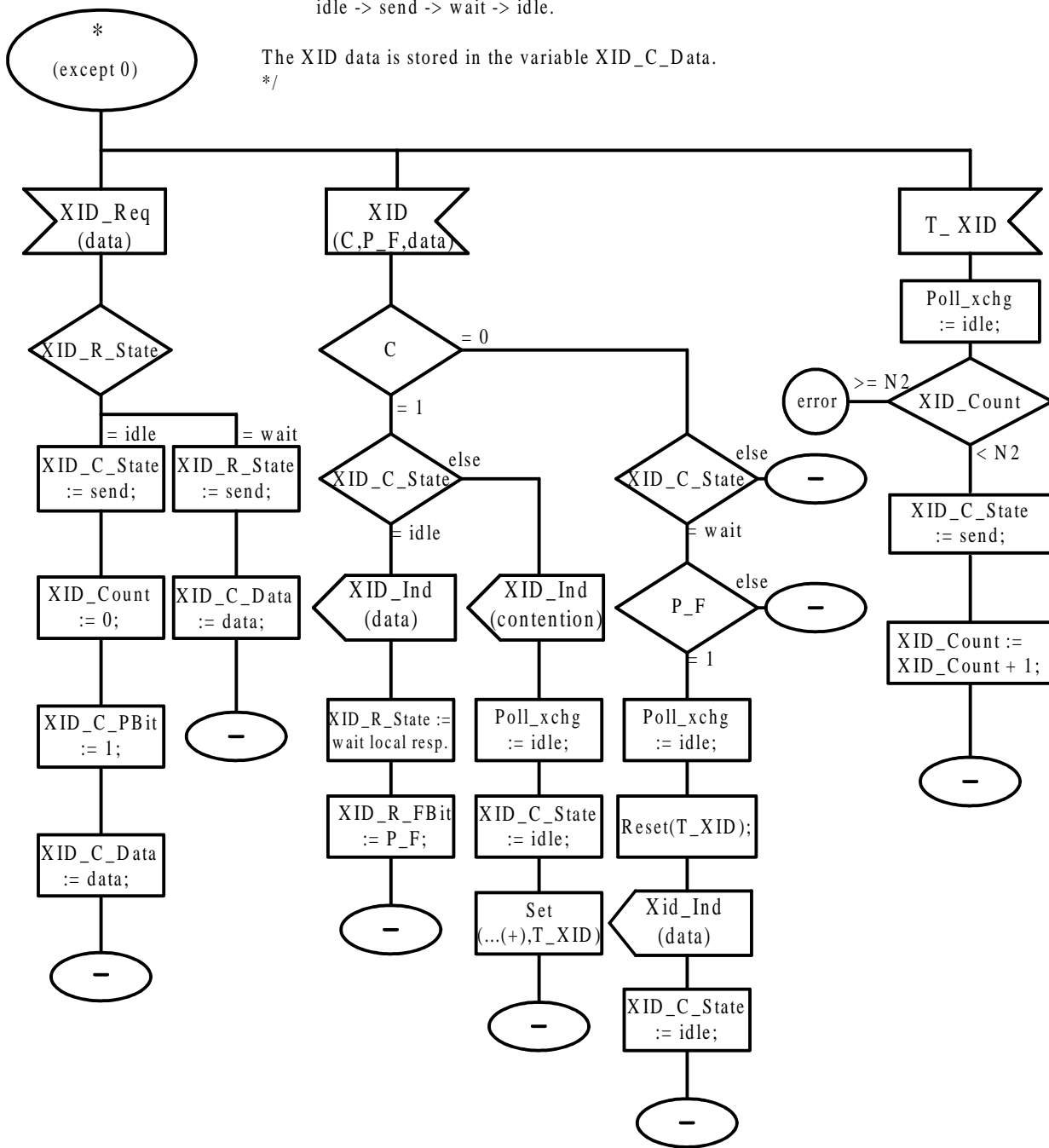

/\*  
The action on a received XID command PDU depends on the state variable XID\_C\_State. In the contention case the XID Command is sent again after a certain delay, depending on the 'location' of the RLP entity.

The XID command/response PDU is sent at the earliest possible opportunity, next after a possible pending TEST PDU (see procedure SEND\_TXU) The value of the timer should be T1 ms in the Mobile Station, it should be twice this value in the Interworking Unit. This scheme is used to avoid repetition of contentions.

\*/

04.22 Annex A, Figure 16

/\*  
 TEST handling (TEST\_Req, TEST\_PDU, TEST\_timeout)  
 \*/

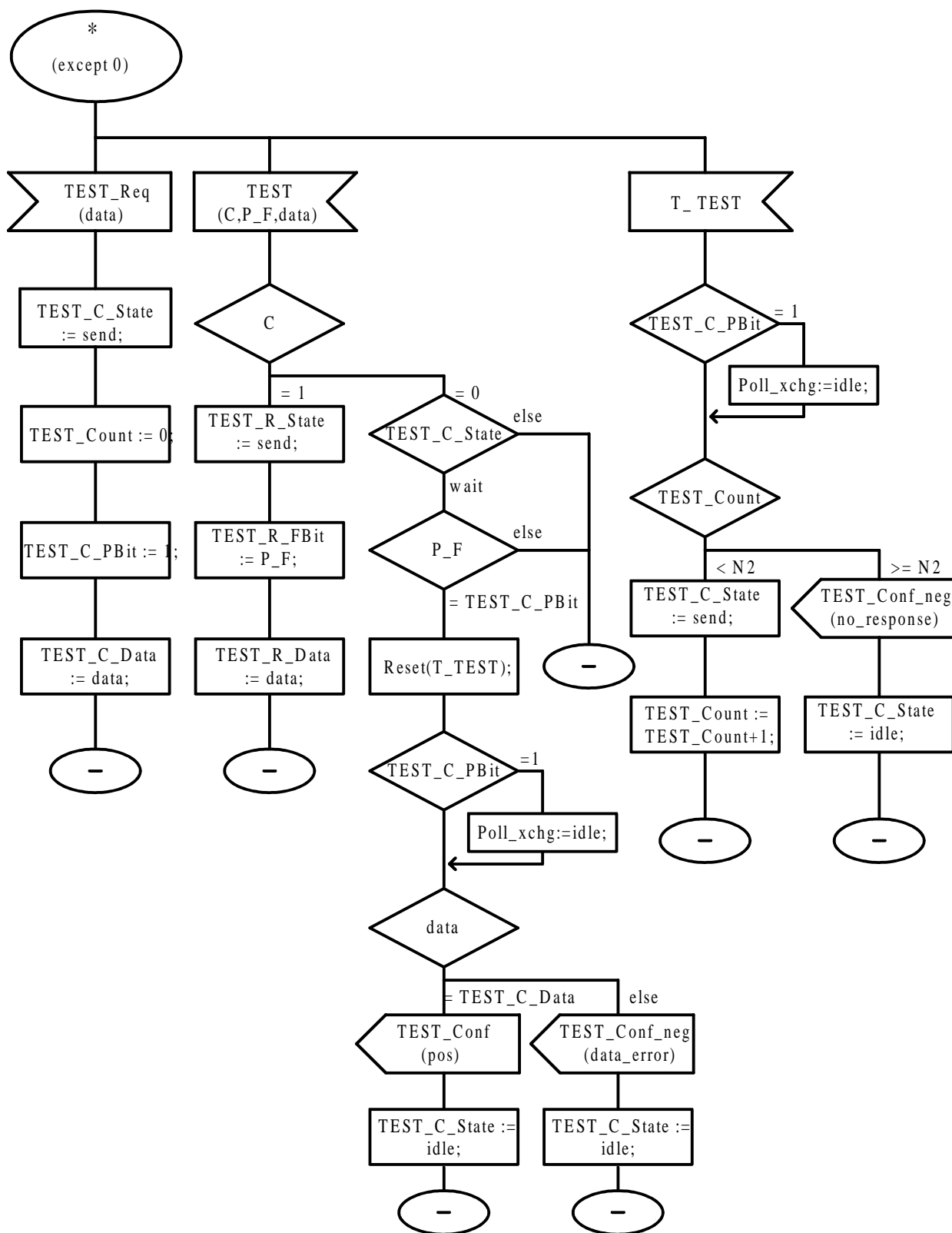

04.22 Annex A, Figure 17



Process Receive\_PDU

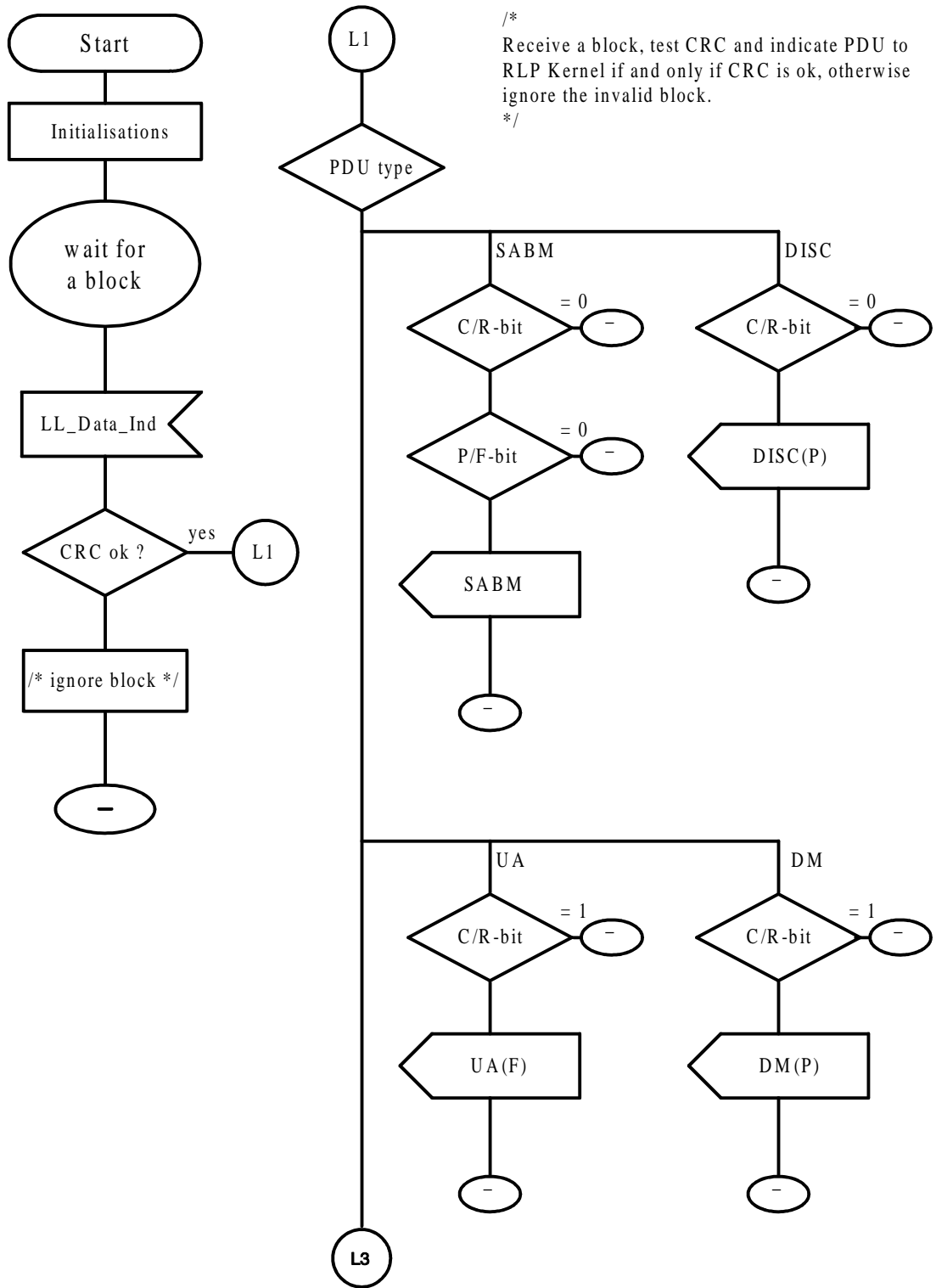

04.22 Annex A, Figure 18

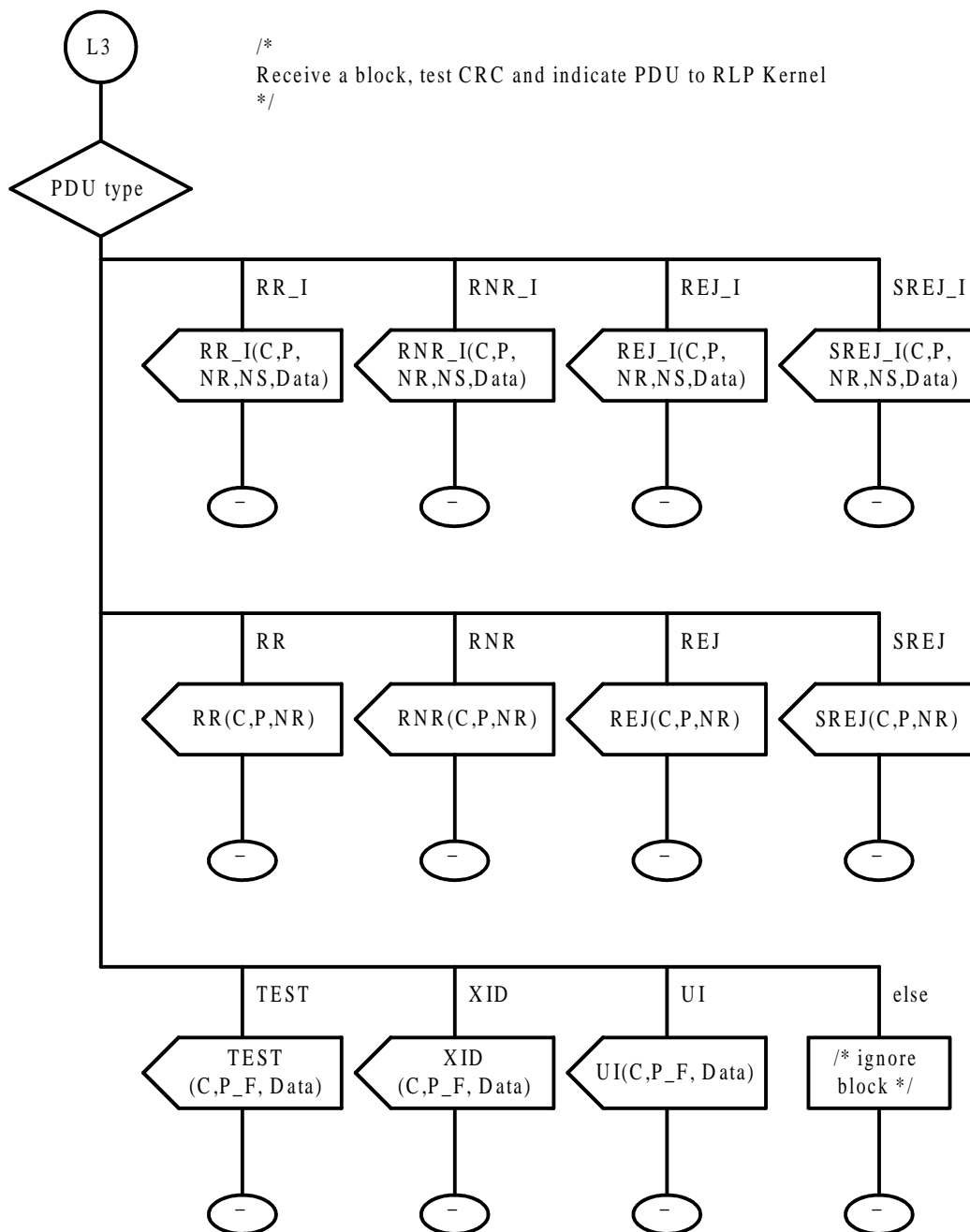

04.22 Annex A, Figure 19

Process Send\_PDU

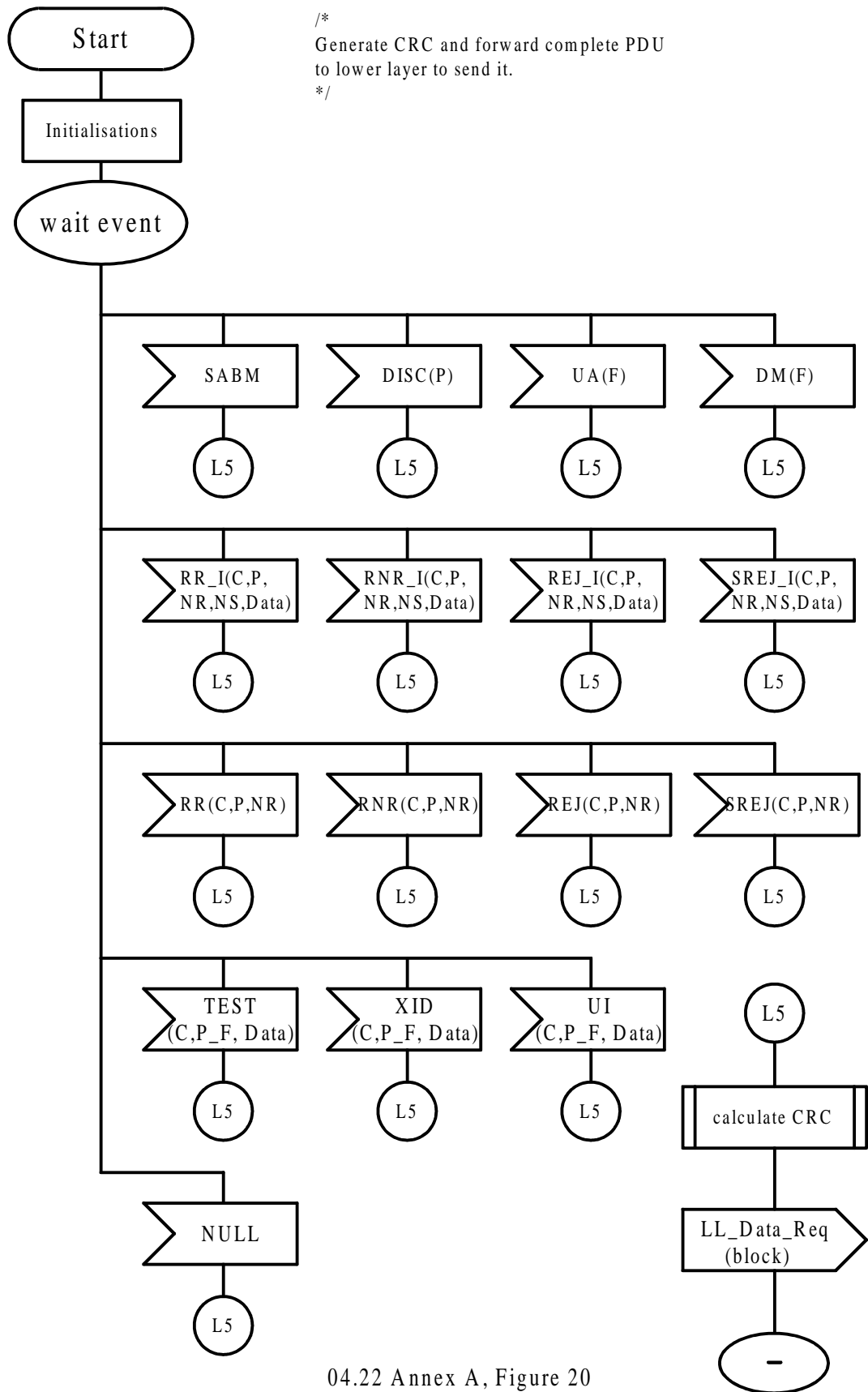

04.22 Annex A, Figure 20

```

/*
Initialise link variables - This procedure is called if the link is established or the link is reset.
*/
    
```

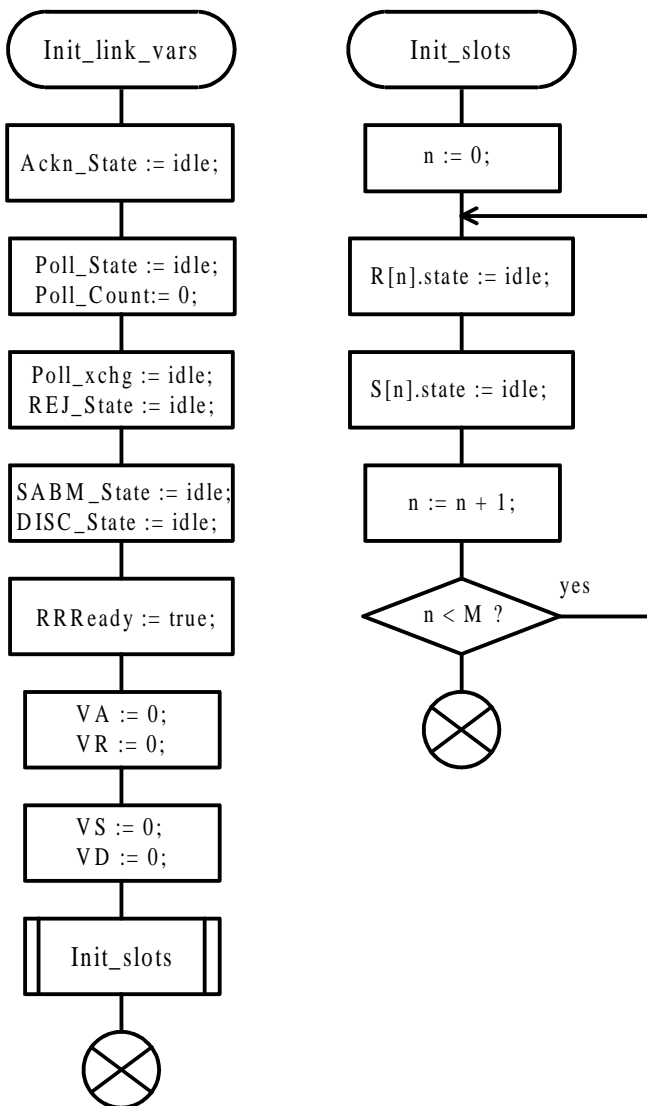

```

/*
There are M data receiver slots and M data sender slots (M <= 62).
    
```

The receiver states are: idle, rcvd, send, wait.

State = idle means: nothing received (with this number),

State = rcvd means: data received, to be delivered and acknowledged only if in sequence.

If delivered, the state becomes idle again.

State = send means: pending retransmission request for this block,

State = wait means : waiting for reception of requested block.

The sender slot states are: idle, send, wait.

State = idle means: nothing to do, slot may be used (again).

State = send means: send data at the next possible opportunity.

State = wait means: wait for the acknowledgement

```

*/
    
```

04.22 Annex A, Figure 21

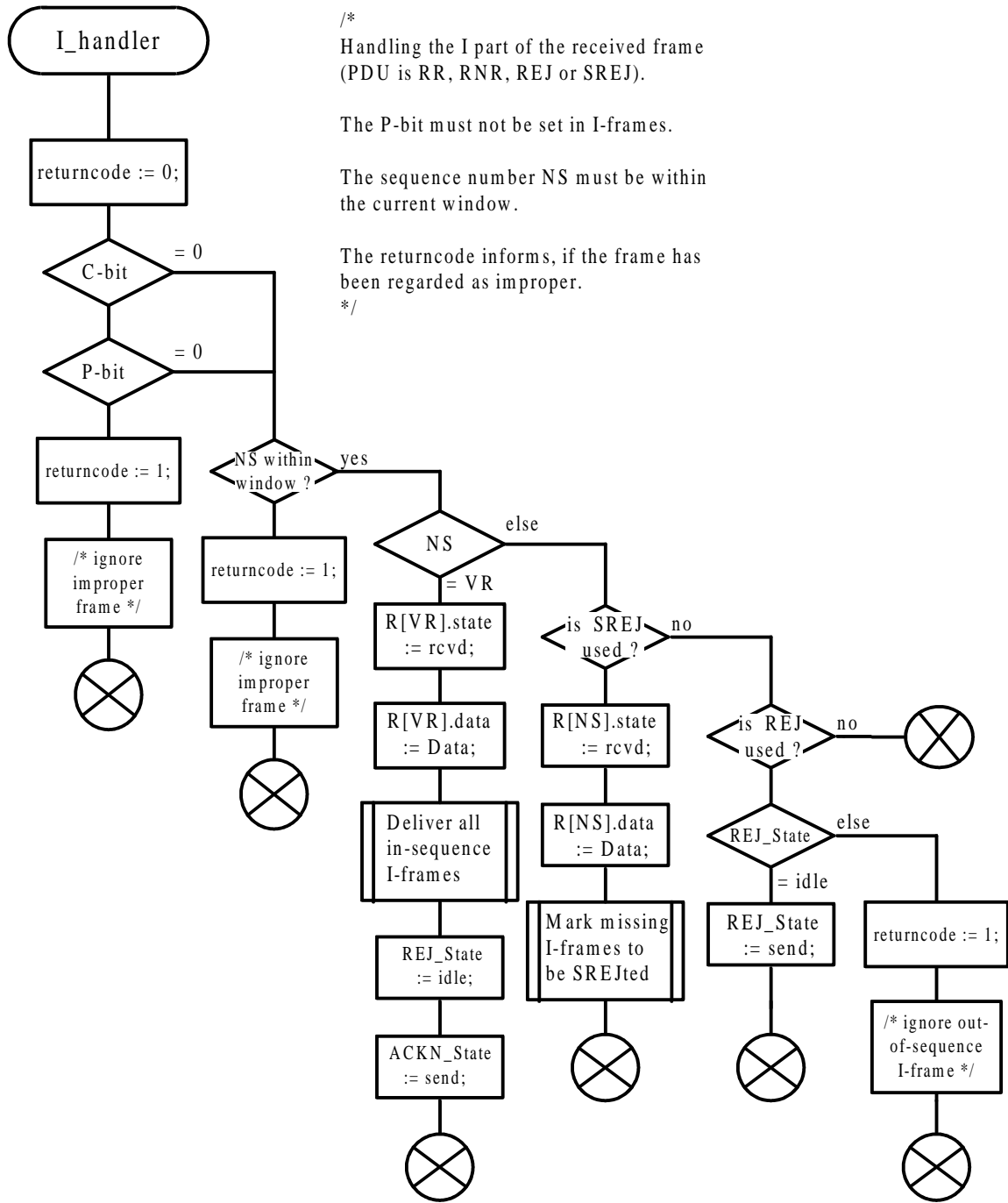

04.22 Annex A, Figure 22

```

/*
Deliver all in-sequence I-frames

Indicate all already received in-sequence
information blocks. There may be more
than one block which has to be indicated
due to successful selective recovery.
*/
    
```

```

/*
mark all missing I-frames

All missing I-frames "between"
VR and NS have to be marked
if their state is idle.
*/
    
```

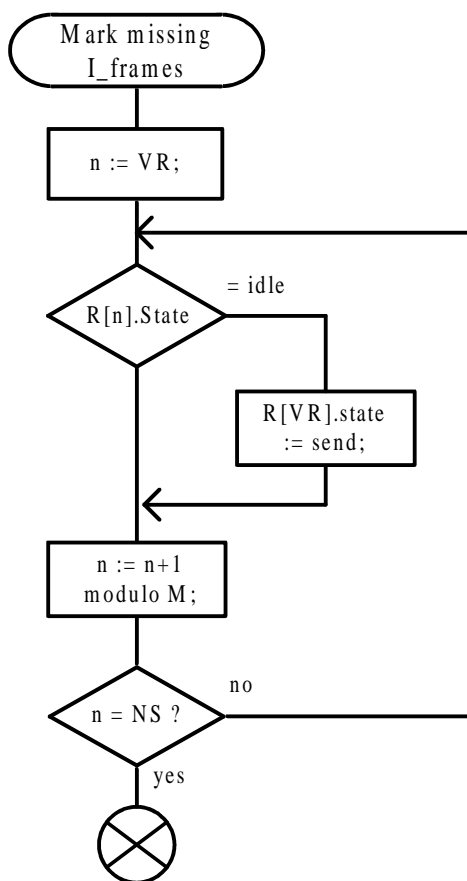
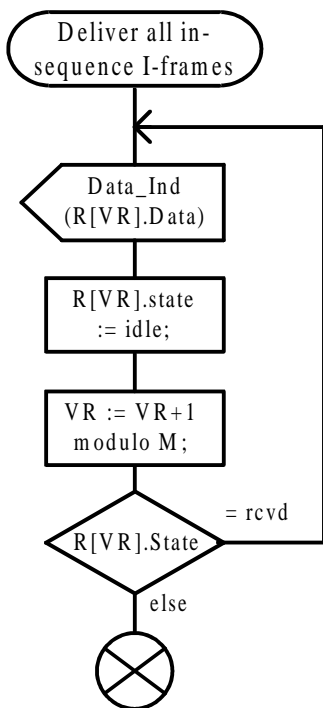

04.22 Annex A, Figure 23

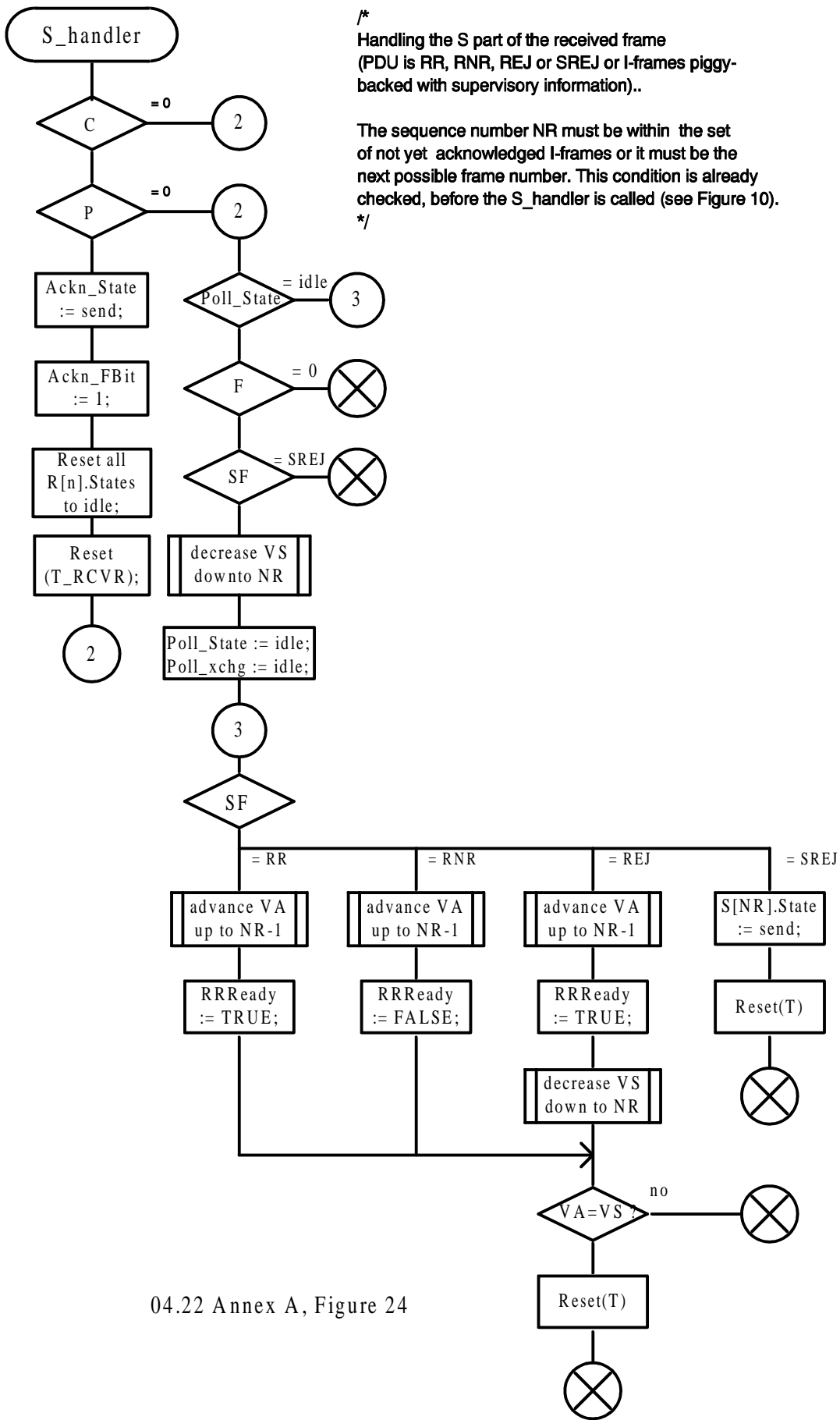

/\*  
 Handling the S part of the received frame  
 (PDU is RR, RNR, REJ or SREJ or I-frames piggy-  
 backed with supervisory information)..

The sequence number NR must be within the set  
 of not yet acknowledged I-frames or it must be the  
 next possible frame number. This condition is already  
 checked, before the S\_handler is called (see Figure 10).

\*/

04.22 Annex A, Figure 24

```
/*  
Advance the lower  
window edge  
*/
```

```
/*  
Set the sender slot  
states to send again  
*/
```

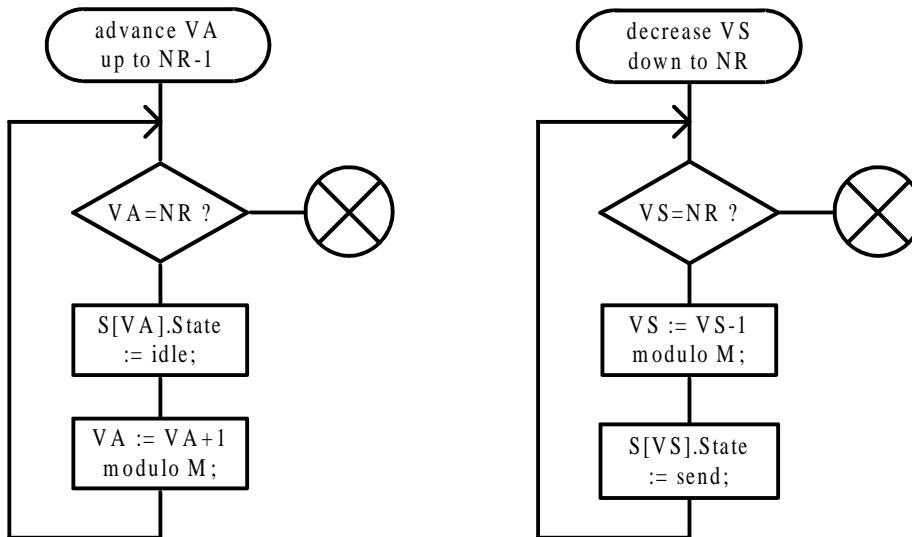

04.22 Annex A, Figure 25



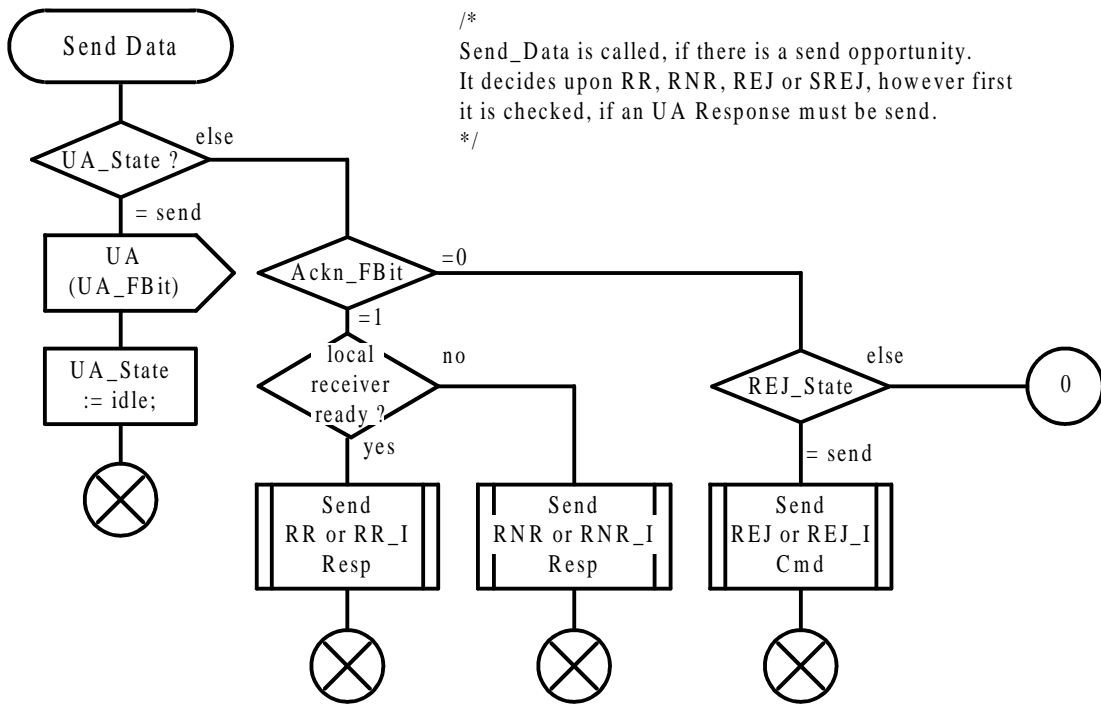

/\*  
 Send\_Data is called, if there is a send opportunity.  
 It decides upon RR, RNR, REJ or SREJ, however first  
 it is checked, if an UA Response must be send.  
 \*/

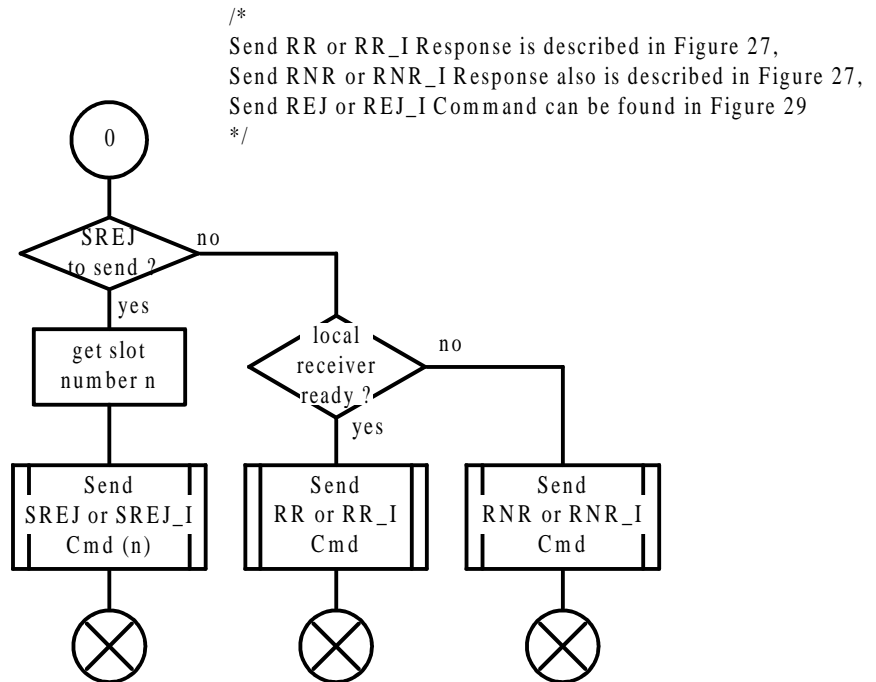

/\*  
 Send RR or RR\_I Response is described in Figure 27,  
 Send RNR or RNR\_I Response also is described in Figure 27,  
 Send REJ or REJ\_I Command can be found in Figure 29  
 \*/

/\*  
 Send SREJ or SREJ\_I Command (n) is described in Figure 30,  
 Send RR or RR\_I Command is described in Figure 28,  
 Send RNR or RNR\_I Command also can be found in Figure 28.  
 \*/

04.22 Annex A, Figure 26

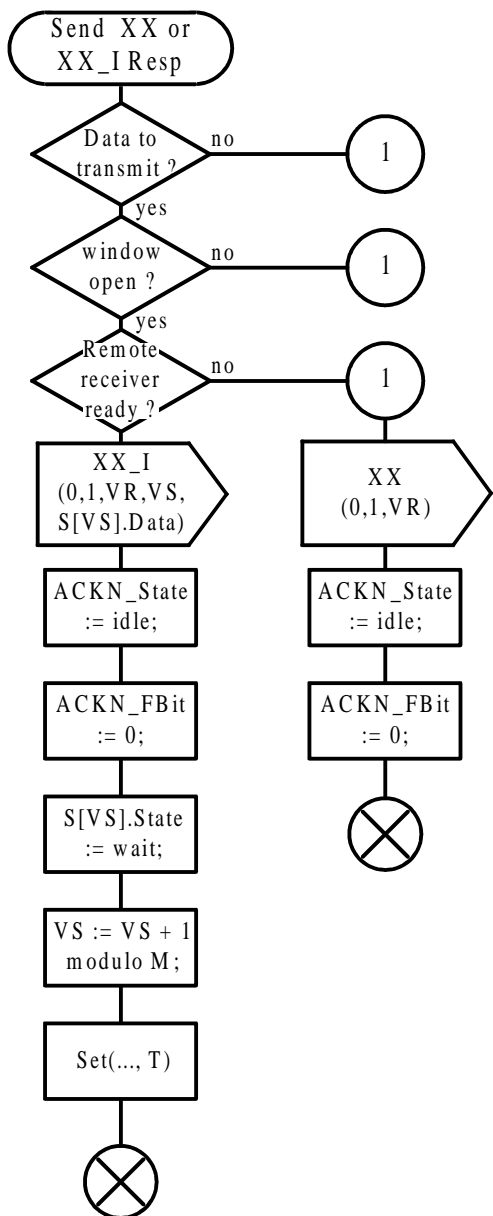

/\*  
 Send XX or XX\_I response PDU with F-Bit set to one.  
 XX may be RR or RNR.  
 \*/

04.22 Annex A, Figure 27

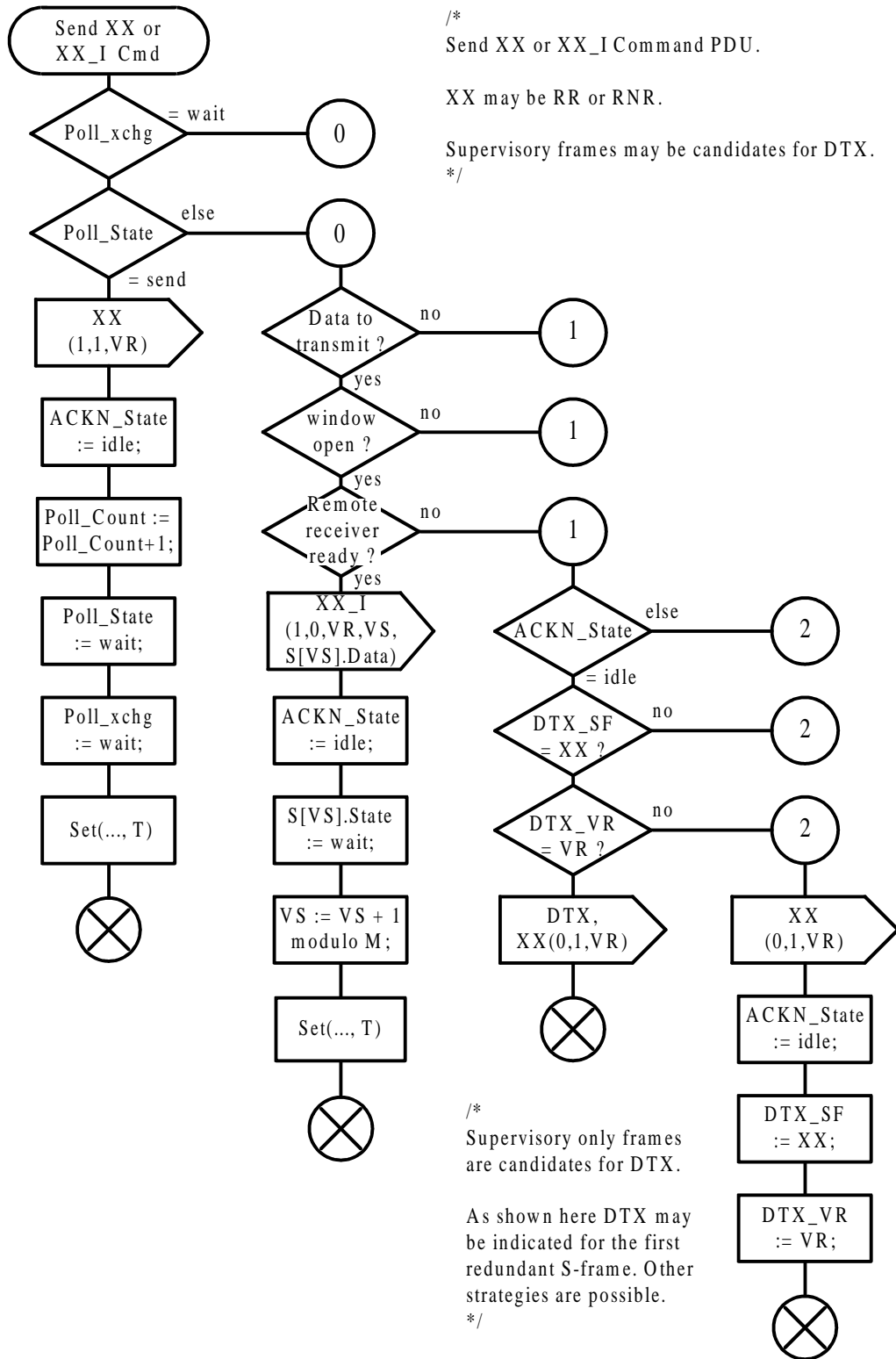

04.22 Annex A, Figure 28

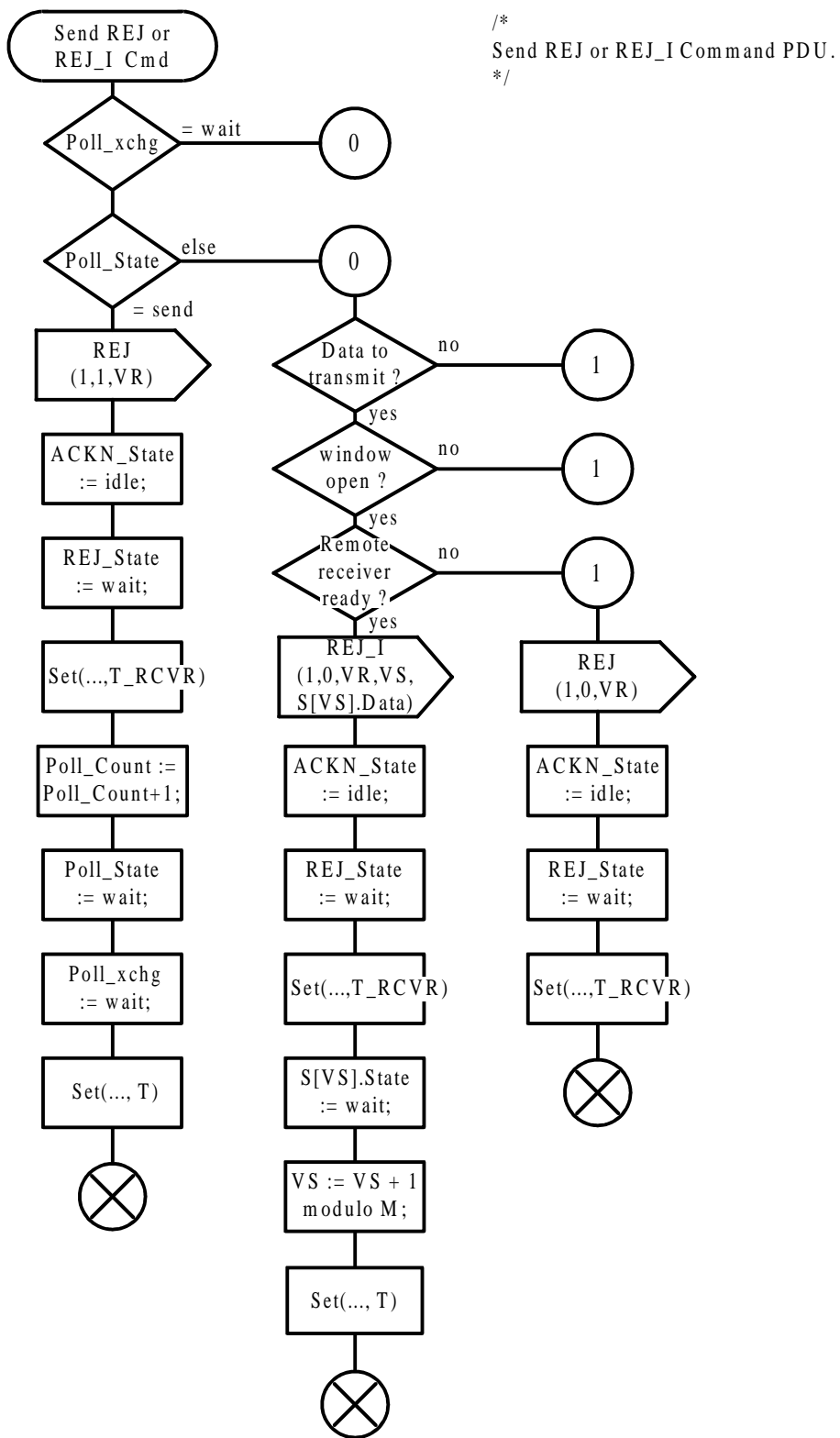

04.22 Annex A, Figure 29

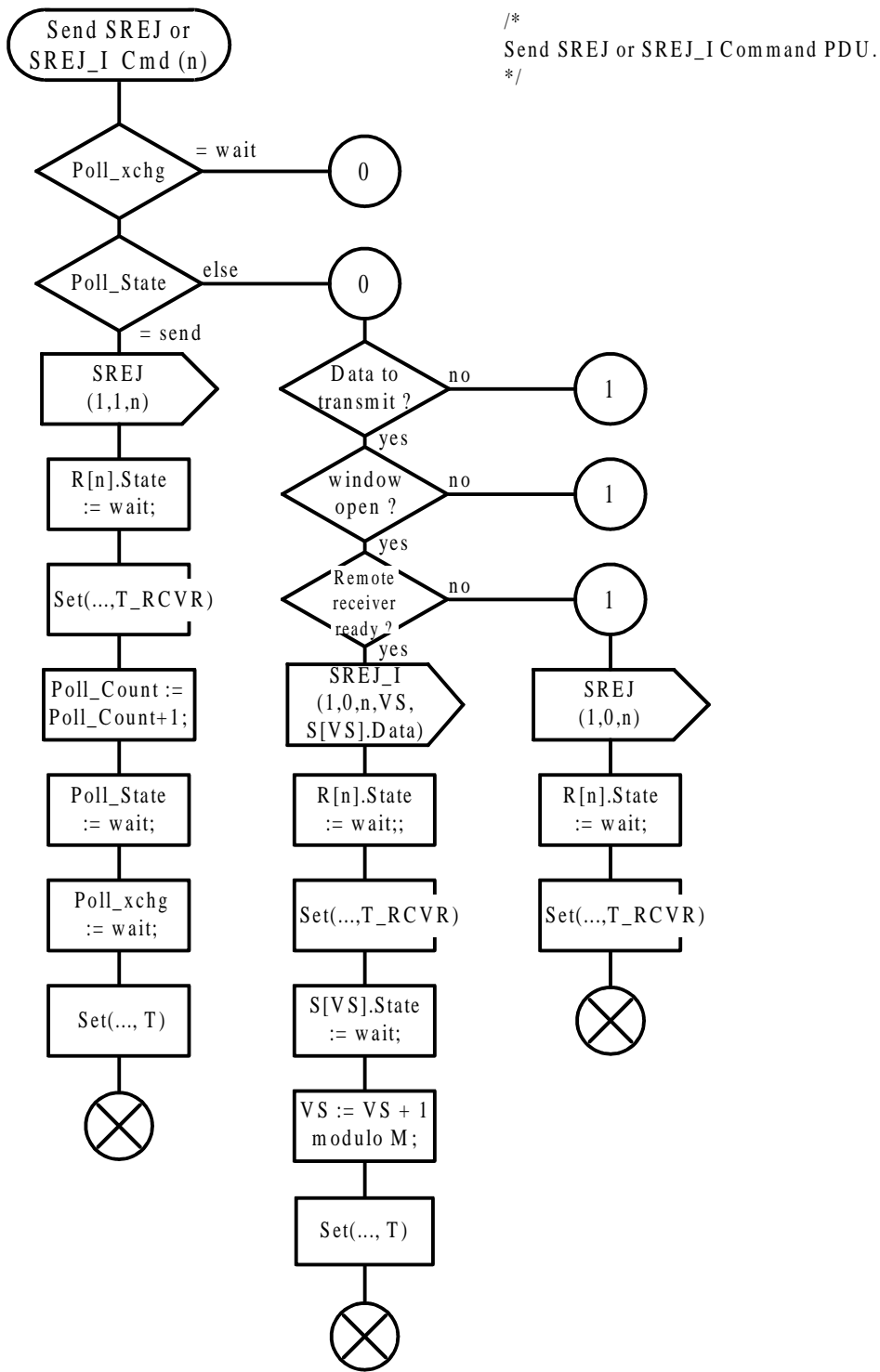

04.22 Annex A, Figure 30

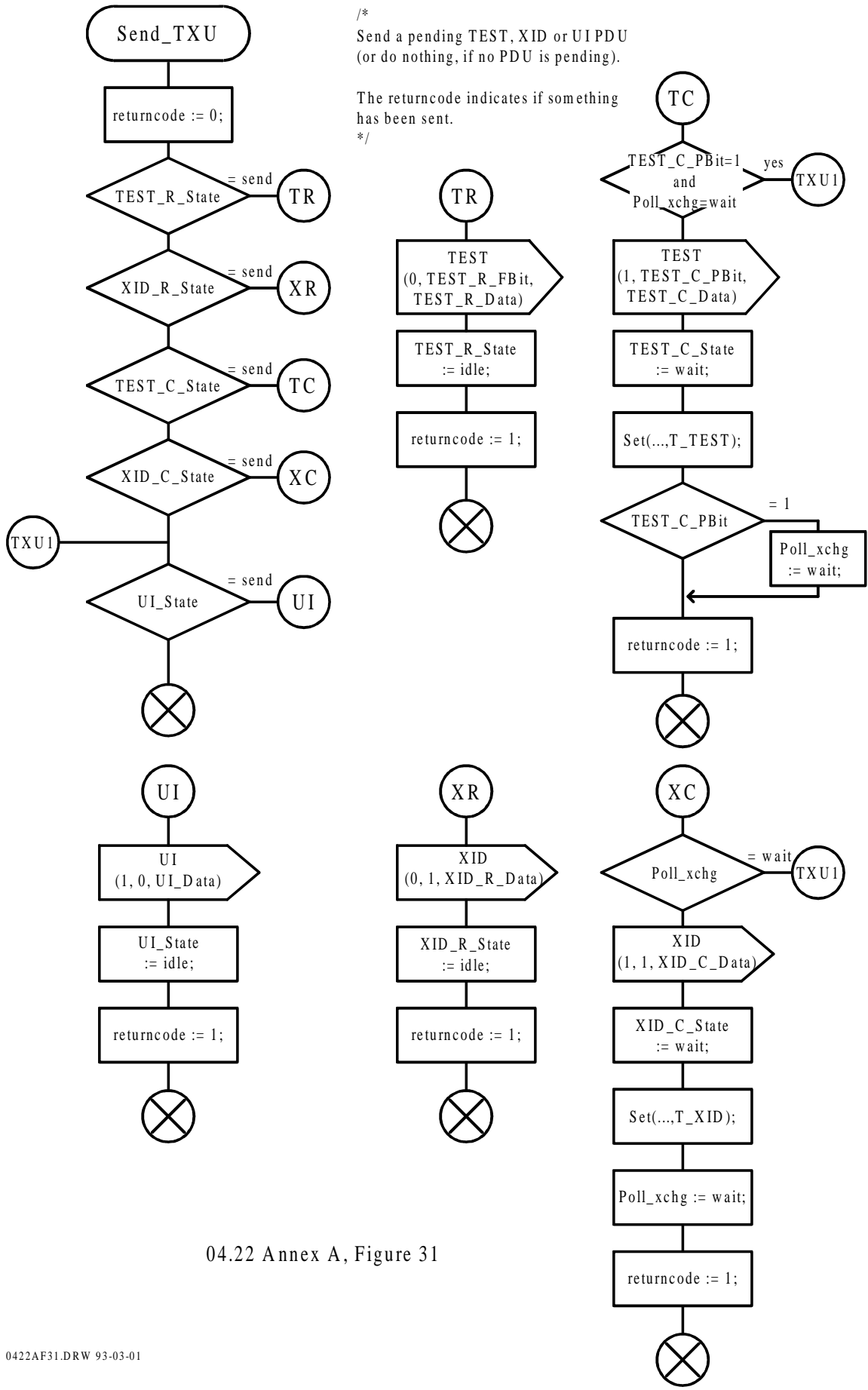

04.22 Annex A, Figure 31

## Annex B (Informative): Change history

SMG	SPEC	CR	PHA	VERS	NEW_VE	SUBJECT
S03	04.22	015	2	4.0.0	4.1.0	Minor editorial corrections and clarifications
S05	04.22	016	2	4.1.0	4.2.0	Using NULL frames in ABM mode
S05	04.22	017	2	4.1.0	4.2.0	Editorial
S06	04.22	018	2	4.2.0	4.2.1	Alignment of SDLs
S07	04.22	019	2	4.2.1		Default value T1
S07	04.22	020	2	4.2.1		Use of P/F bit
S07	04.22	021	2	4.2.1	4.2.2	Correction of SDL's in Annex A
S08	04.22	022	2	4.2.2		Retransmission of SREJ
S08	04.22	023	2	4.2.2		SREJ frames having F bit set to 1
S08	04.22	024	2	4.2.2	4.3.0	Duplication of I frames
S13	04.22	A001				RLP Timer for Full rate on 6 kbit/s
S13	04.22	A002				Editorial
S13	04.22	A003				User Response "ConnRespNeg"
S15	04.22	A004				Data Compression
S25	04.22	A014	2	4.4.0	4.5.0	Improvements requested by SMG7 Phase 2

## History

Document history	
September 1994	First Edition
May 1998	One-step Approval Procedure (Second Edition) OAP 9841: 1998-05-20 to 1998-10-16