



EUROPEAN
TELECOMMUNICATION
STANDARD

ETS 300 562

September 1994

Source: ETSI TC-SMG

Reference: DE/SMG-040421P

ICS: 33.060.30

Key words: European digital cellular telecommunications system, Global System for Mobile communications (GSM)

**European digital cellular telecommunications system (Phase 2);
Rate adaption on the Mobile Station - Base Station System
(MS - BSS) interface
(GSM 04.21)**

ETSI

European Telecommunications Standards Institute

ETSI Secretariat

Postal address: F-06921 Sophia Antipolis CEDEX - FRANCE

Office address: 650 Route des Lucioles - Sophia Antipolis - Valbonne - FRANCE

X.400: c=fr, a=atlas, p=etsi, s=secretariat - **Internet:** secretariat@etsi.fr

Tel.: +33 92 94 42 00 - Fax: +33 93 65 47 16

Copyright Notification: No part may be reproduced except as authorized by written permission. The copyright and the foregoing restriction extend to reproduction in all media.

© European Telecommunications Standards Institute 1994. All rights reserved.

Contents

Foreword.....	5
0 Scope	7
1 Normative references	7
2 Abbreviations	8
3 General Approach	8
4 The RA0 Function.....	8
4.1 Asynchronous-to-Synchronous Conversion (RA0).....	8
4.2 Break Signal	8
4.3 Overspeed/Underspeed.....	9
4.4 Parity Bits.....	9
4.5 Flow Control	9
5 The RA1 Function.....	9
5.1 Network Independent Clocking	10
5.1.1 Multiframe Structure	10
5.1.2 Encoding and compensation	11
6 The RA2 Function.....	11
7 The RA1/RA1' Function.....	12
7.1 Radio Interface rate of 12 kbit/s.....	13
7.2 Radio Interface rate of 6 kbit/s.....	14
7.3 Radio Interface rate of 3.6 kbit/s (transparent services only)	15
7.4 Synchronisation.....	15
7.5 Idle frames	15
8 The RA1' Function	16
9 Support of Non-Transparent Bearer Services	16
ANNEX (Informative) Stacks of rate adaptation	20
History	21

Blank page

Foreword

This European Telecommunication Standard (ETS) has been produced by the Special Mobile Group (SMG) Technical Committee (TC) of the European Telecommunications Standards Institute (ETSI).

This ETS defines the rate adaptation functions to be used in Mobile Stations (MS) for adapting terminal interface data rates to the Mobile Station - Base Station System (MS - BSS) interface data rates, within the European digital cellular telecommunications system (Phase 2).

This ETS correspond to GSM technical specification, GSM 04.21 version 4.4.1.

The specification from which this ETS has been derived was originally based on CEPT documentation, hence the presentation of this ETS may not be entirely in accordance with the ETSI/PNE rules.

Reference is made within this ETS to GSM Technical Specifications (GSM-TS) (NOTE).

Reference is also made within this draft ETS to GSM 07.xx. series. The specifications in the series can be identified, with their full title, within the normative reference Clause of this draft ETS by the first two digits of their GSM reference number e.g. GSM 07.xx series, refers to GSM 07.01, GSM 07.02, .etc.

NOTE: TC-SMG has produced documents which give the technical specifications for the implementation of the European digital cellular telecommunications system. Historically, these documents have been identified as GSM Technical Specifications (GSM-TS). These TSs may have subsequently become I-ETSs (Phase 1), or ETSs (Phase 2), whilst others may become ETSI Technical Reports (ETRs). GSM-TSs are, for editorial reasons, still referred to in current GSM ETSs.

Blank page

0 Scope

This specification defines the rate adaptation functions to be used in GSM PLMN Mobile Stations for adapting terminal interface data rates to the MS-BSS interface data rates in accordance with GSM 03.10.

The provision of these functions will depend on the services a particular station is designed to support.

Note: This Specification should be considered together with GSM Specification 08.20 (Rate Adaptation on the BSS-MSC Interface) to give a complete description of PLMN rate adaptation.

1 Normative references

This ETS incorporates by dated and undated reference, provisions from other publications. These normative references are cited at the appropriate places in the text and the publications are listed hereafter. For dated references, subsequent amendments to or revisions of any of these publications apply to this ETS only when incorporated in it by amendment or revision. For undated references, the latest edition of the publication referred to applies.

- [1] GSM 01.04 : "European digital cellular telecommunication system (Phase 2); Definitions, abbreviations and acronyms".
- [2] GSM 03.10 (ETS 300 528): "European digital cellular telecommunication system (Phase 2); GSM Public Land Mobile Network (PLMN) connection types".
- [3] GSM 05.03 (ETS 300 575): "European digital cellular telecommunication system (Phase 2); Channel coding".
- [4] GSM 07.01 (ETS 300 582): "European digital cellular telecommunication system (Phase 2); General on Terminal Adaptation Functions (TAF) for Mobile Stations (MS)".
- [5] GSM 07.02 (ETS 300 583): "European digital cellular telecommunication system (Phase 2); Terminal Adaptation Functions (TAF) for services using asynchronous bearer capabilities".
- [6] GSM 07.03 (ETS 300 584): "European digital cellular telecommunication system (Phase 2); Terminal Adaptation Functions (TAF) for services using synchronous bearer capabilities".
- [7] GSM 07.05 (ETS 300 585): "European digital cellular telecommunication system (Phase 2); Use of Data Terminal Equipment - Data Circuit terminating Equipment (DTE - DCE) interface for Short Message Service (SMS) and Cell Broadcast Service (CBS)".
- [8] GSM 07.06 (ETS 300 586): "European digital cellular telecommunication system (Phase 2); Use of the V series Data Terminal Equipment - Data Circuit terminating Equipment (DTE - DCE) interface at the Mobile Station (MS) for Mobile Termination (MT) configuration".
- [9] GSM 08.20 (ETS 300 591): "European digital cellular telecommunication system (Phase 2); Rate adaption on the Base Station System - Mobile-services Switching Centre (BSS - MSC) interface".
- [10] CCITT Recommendation V.110: "Support of data terminal equipments (DTEs) with V-Series interfaces by an integrated services digital network".
- [11] CCITT Recommendation X.30: "Support of X.21,X.21 bis and X.20 bis based terminal equipments (DTEs) by integrated services digital network (ISDN)".

2 Abbreviations

Abbreviations used in this specification are listed in GSM 01.04.

3 General Approach

GSM 03.10 defines the PLMN connection types necessary to support the GSM PLMN data and telematic services.

Within the MS there are several different data rate adaptation functions which are combined as shown in GSM 03.10 as part of the connection type.

These functions are RA0, RA1, RA2, RA1' and RA1/RA1'. The RA0, RA1 and RA2 are equivalent to those functions described in CCITT recommendation V.110.

The RA1' function is similar to RA1 but has a reduced bit rate output compatible with the coding scheme proposed for data services on the radio interface.

The RA1/RA1' is a relay function, used as indicated in GSM 03.10.

4 The RA0 Function

4.1 Asynchronous-to-Synchronous Conversion (RA0)

The RA0 Function is only used with asynchronous interfaces. Incoming asynchronous data is padded by the addition of stop elements to fit the nearest channel defined by $(2 \text{ to the power } n)$ times 600 bit/s. Thus both 75 bit/s and 300 bit/s user data signalling rates shall be adapted to a synchronous 600 bit/s stream. The resultant synchronous stream is fed to RA1 or RA1'.

Asynchronous user rate	Synchronous user rate
0.6 kbit/s	0.6 kbit/s
1.2 kbit/s	1.2 kbit/s
2.4 kbit/s	2.4 kbit/s
4.8 kbit/s	4.8 kbit/s
9.6 kbit/s	9.6 kbit/s

4.2 Break Signal

The RA0 shall detect and transmit the break signal in the following fashion:

If the converter detects M to $2M+3$ bits, all of start polarity, where M is the number of bits per character in the selected format including start and stops bits, the converter shall transmit $2M+3$ bits of start polarity.

If the converter detects more than $2M+3$ bits all of start polarity, the converter shall transmit all these bits as start polarity.

The $2M+3$ or more bits of start polarity received from the transmitting sides shall be output to the receiving terminal.

The terminal must transmit on circuit 103 at least $2M$ bits stop polarity after the start polarity break signal before sending further data character. The converter shall then regain character synchronism from the following stop to start transition.

4.3 Overspeed/Underspeed

A RA0 shall insert additional stop elements when its associated terminal is transmitting with a lower than nominal character rate. If the terminal is transmitting characters with an overspeed of up to 1% (or 2.5% in the case of nominal speeds lower than 600 bit/s), the asynchronous-to-synchronous converter may delete stop elements as often as is necessary to a maximum of one for every eight characters at 1% overspeed. The converter on the receiving side shall detect the deleted stop elements and reinsert them in the received data stream (circuit 104).

The nominal length of the start and data elements shall be the same for all characters. The length of the stop elements may be reduced by as much as 12.5% for nominal speeds exceeding 300 bit/s to allow for overspeed in the transmitting terminal. For nominal speeds less than or equal to 300 bit/s a 25% reduction in stop element is allowed.

4.4 Parity Bits

Possible parity bits included in the user data are considered as data bits by the RA0 function (and RA1 function).

4.5 Flow Control

Where applicable, this function is as specified in the relevant terminal adaptation function Specification (GSM 07 series).

5 The RA1 Function

This function is used to adapt between the synchronous user rates, or the output of the RA0 function and the intermediate rate of 8 or 16 kbit/s.

Synchronous user rate	Intermediate rate
2.4 kbit/s	8 kbit/s
4.8 kbit/s	8 kbit/s
9.6 kbit/s	16 kbit/s

A CCITT V.110 80 bits frame is constructed using the user data bits received (from the RA0 in the asynchronous case), the values of the S bits are deduced from the R interface.

Adaptation of 600 bit/s to 8Kbit/s is performed by 8 times consecutive duplication of each user data bit.

Adaptation of 1200 bit/s to 8 Kbit/s is performed by 4 times consecutive duplication of each user data bit.

Adaptation of 2400 bit/s to 8kbit/s is performed by 2 times consecutive duplication of each user data bit.

Adaptation of 4800 bit/s to 8 Kbit/s is performed by transmitting the bit stream with no duplication.

Adaptation of 9600 bit/s to 16 Kbit/s is performed by transmitting the bit stream with no duplication (the emitting period is halved with respect to the 4800 bit/s case).

The CCITT V.110 80 bit frame shown in Figure 3 is used. The D bits are used to convey the user data and the S and X bits are used to convey channel control information according to the relevant terminal adapter function Specification.

The E bits are used to convey the following information:

- i) User Data Rate - E1, E2, E3 (see Figure 4)
- ii) Network Independent Clocking - E4, E5, E6

iii) Multiframe Synchronisation - E7

The order of transmission of the 80 bit frame is from left to right and top to bottom.

5.1 Network Independent Clocking

Synchronous data signals received by the MT from the DTE at the MS or by IWF from the modem on the PSTN may not be synchronised to the PLMN. The following method shall be used to enable transfer of those data signals and the corresponding bit timing information via the V.110 frames. Such a situation would exist where the signals received from the modem at the IWF require its own clock or where the signals received from the DTE at the MS employs its own network independent clock. In any case, the frequency tolerance of the clocks involved is 100 ppm.

5.1.1 Multiframe Structure

The transmitting end of the GSM PLMN connection shall establish a multiframe structure utilising bit E7 consisting of four frames by setting E7 in every fourth frame to binary 0. This structure is identical to the use of E7 in V.110 (and X.30) except that such a multiframe structure will exist for all user data rates. This frame synchronization will be achieved and maintained during the entire call so that corrections for the network independent clocking by the receiving end of the GSM PLMN connection can be easily recognized and applied based on the code words (in c1,c2,c3,c4 and c5) positioned in bits E4, E5 and E6 of two consecutive V.110 frames as illustrated in figure 1. Thus, the multiframe structure allows for one 5-bit code words to be transmitted every two V.110 frames for the purposes of network independent clocking. The two code-words may be different from each other within the multiframe shown in figure 1.

Frame	E4	E5	E6	E7
MF 0a	c1	c2	1	0
MF 1a	c3	c4	c5	1
MF 0b	c1	c2	1	1
MF 1b	c3	c4	c5	1

Figure 1 NIC Multiframe Structure

Once Multiframe synchronization is achieved, each code word is independently evaluated to determine the compensation needed, if any. The compensation is applied as explained in section 3.1.2 in V.110 frames MF 1a and MF 1b.

5.1.2 Encoding and compensation

The V.110 transmitter will use the following 5-bit code words, as shown in figure 2, to indicate the four possible states of compensation required for network independent clocking.

	c1	c2	c3	c4	c5
No compensation	1	1	1	1	1
Negative compensation	1	0	0	1	0
Positive compensation of a zero	0	1	0	0	1
Positive compensation of one	0	0	1	0	0

Figure 2 NIC Code Words

When negative compensation is indicated, one less user data bit than normal is transported in the affected frame (MF1a or MF1b). A negative compensation shall cause the receiver to delete the user data bit occupied by bit position D25, since the transmitter sets this to binary 1 and does not utilize this position for user data. At those user data rates where the user data bit is repeated, all copies of D25 shall be discarded.

When a positive compensation is indicated, one additional user data bit is transferred by means of the code word. At the receiver, a positive compensation will cause a user data bit of binary value 0 or 1, as indicated by the code word, to be inserted between the user data bits carried in bit positions D24 and D25 (in MF1a or MF1b) of the V.110 frame illustrated in figure 3.

When no compensation is necessary, or when NIC is applied, the values of E4, E5, E6, E7, on the 4 multi frame scheme is

Frame	E4	E5	E6	E7
MF 0a	1	1	1	0
MF 1a	1	1	1	1
MF 0b	1	1	1	1
MF 1b	1	1	1	1

6 The RA2 Function

This procedure is based on the RA2 function as specified in CCITT V.110. It is used to rate adapt to/from the intermediate rates of 8 or 16 kbit/s from/to the 64 kbit/s rate used at the S interface.

Intermediate rate	Rate at the S interface
8 kbit/s	64 kbit/s
16 kbit/s	64 kbit/s

It considers the 64 kbit/s stream to consist of octets, bits 1 through 8, with bit 1 being transmitted first.

The procedure requires that:

- i) The 8 kbit/s stream occupies bit position 1;
- ii) The 16 kbit/s bitstream occupies bit positions (1,2);
- iii) The order of transmission of the bits of the subrate stream is identical before and after rate adaptation.
- iv) All unused bits in the 64 kbit/s stream are set to binary "1".

7 The RA1/RA1' Function

The RA1/RA1' function is used to convert between the CCITT V.110 80 bit frames produced at the 8 and 16 kbit/s intermediate rates and the input rate to the channel coder function for transmission by the radio subsystem.

Intermediate rate	Radio interface rate
8 kbit/s	3.6 kbit/s
8 kbit/s	6 kbit/s
16 kbit/s	12 kbit/s

There are three data rates (known as Radio Interface rates) used for data transfer to the channel coder. These are 12 kbit/s, 6 kbit/s and 3.6 kbit/s, and in order to adapt the 8 and 16 kbit/s intermediate rates to these data rates, three processes are used.

Firstly the 17 synchronisation bits are removed.

Secondly the E1, E2 and E3 bits are removed. For transparent services, the values of the E1, E2, E3 bits are determined at the MT and the BTS based on the indication given by outband signalling (either in the User Rate field of the BC-IE of the SETUP message for the MT or in the Channel Type information in the ASSIGNMENT REQUEST message for the BSS). For non transparent services, the coding of the E1, E2 and E3 bits is described in GSM 08.20.

Thirdly, in the 3.6 kbit/s case, half the data bits are discarded. These processes result in modified CCITT V.110 frames of sizes 60,60 and 36 bits for the 12, 6 and 3.6 kbit/s data rates respectively. The resultant modified CCITT V.110 frames for the various user data rates are shown in figures 5-9.

7.1 Radio Interface rate of 12 kbit/s

In this case one modified CCITT V.110 60 bit frame is received/sent from/to the radio subsystem every 5ms (see GSM 05.03). The RA1/RA1' function will add/subtract the 17 bit synchronisation pattern and the EI, E2 and E3 bits to/from each CCITT V.110 80 bit frame as follows:

The modified CCITT V.110 60 bits frame received/sent from/to the air interface at 12 Kbit/s,

D1	D2	D3	D4	D5	D6	S1
D7	D8	D9	D10	D11	D12	X
D13	D14	D15	D16	D17	D18	S3
D19	D20	D21	D22	D23	D24	S4
E4	E5	E6	E7	D25	D26	D27
D28	D29	D30	S6	D31	D32	D33
D34	D35	D36	X	D37	D38	D39
D40	D41	D42	S8	D43	D44	D45
D46	D47	D48	S9			

is converted into the following a CCITT V.110 80 bits frame at 16 Kbit/s:

0	0	0	0	0	0	0	0
1	D1	D2	D3	D4	D5	D6	S1
1	D7	D8	D9	D10	D11	D12	X
1	D13	D14	D15	D16	D17	D18	S3
1	D19	D20	D21	D22	D23	D24	S4
1	E1	E2	E3	E4	E5	E6	E7
1	D25	D26	D27	D28	D29	D30	S6
1	D31	D32	D33	D34	D35	D36	X
1	D37	D38	D39	D40	D41	D42	S8
1	D43	D44	D45	D46	D47	D48	S9

In the case of the non transparent services, bits S1, X, S3, S4, E4, E5, E6, E7, S6, X (second occurrence), S8, and S9 carry bits D'1, D'2, D'3, D'4, D'5, D'6, D'7, D'8, D'9, D'10, D'11, and D'12, respectively.

For a modified CCITT V.110 60 bit frames received from the radio subsystem, the received D, S and X bits or D and D' bits are set to the same value as the transmitted bits. Bits E1, E2, E3 are set according to the user data rate as shown in Figure 4 for the transparent services, or the RLP multiframe and DTX indication as per GSM 08.20 in the non transparent case.

For modified CCITT V.110 60 bit frames transmitted over the radio subsystem, the received D, S, and X bits or D and D' are set to the same value as the transmitted bits. Bits E1, E2, E3 are discarded.

7.2 Radio Interface rate of 6 kbit/s

In this case one modified CCITT V.110 60 bit frame is received/sent from/to the radio subsystem every 10ms (see GSM 05.03). The RA1/RA1' function will add/subtract the 17 bit synchronisation pattern and the E1,E2 and E3 bits to/from each CCITT V.110 80 bit frame as follows:

The modified CCITT V.110 60 bits frame received/sent from/to the air interface at 6 Kbit/s,

D1	D2	D3	D4	D5	D6	S1
D7	D8	D9	D10	D11	D12	X
D13	D14	D15	D16	D17	D18	S3
D19	D20	D21	D22	D23	D24	S4
E4	E5	E6	E7	D25	D26	D27
D28	D29	D30	S6	D31	D32	D33
D34	D35	D36	X	D37	D38	D39
D40	D41	D42	S8	D43	D44	D45
D46	D47	D48	S9			

is converted into the following a CCITT V.110 80 bits frame at 8 Kbit/s:

0	0	0	0	0	0	0	0
1	D1	D2	D3	D4	D5	D6	S1
1	D7	D8	D9	D10	D11	D12	X
1	D13	D14	D15	D16	D17	D18	S3
1	D19	D20	D21	D22	D23	D24	S4
1	E1	E2	E3	E4	E5	E6	E7
1	D25	D26	D27	D28	D29	D30	S6
1	D31	D32	D33	D34	D35	D36	X
1	D37	D38	D39	D40	D41	D42	S8
1	D43	D44	D45	D46	D47	D48	S9

In the case of the non transparent services, bits S1, X, S3, S4, E4, E5, E6, E7, S6, X (second occurrence), S8, and S9 carry bits D'1, D'2, D'3, D'4, D'5, D'6, D'7, D'8, D'9, D'10, D'11, and D'12, respectively.

For a modified CCITT V.110 60 bit frames received from the radio subsystem, the received D, S and X bits or D and D' bits are set to the same value as the transmitted bits. Bits E1, E2, E3 are set according to the user data rate as shown in Figure 4 for the transparent services, or the RLP multiframe and DTX indication as per GSM 08.20 in the non transparent case.

For modified CCITT V.110 60 bit frames transmitted over the radio subsystem, the received D, S, and X bits or D and D' bits are set to the same value as the transmitted bits. Bits E1, E2, E3 are discarded.

It should be noted that this process is identical to that used for the 12 kbit/s case except that the frame repetition rates are halved.

7.3 Radio Interface rate of 3.6 kbit/s (transparent services only)

In this case one modified CCITT V.110 36 bit frame is received/sent from/to the radio subsystem every 10ms (see GSM 05.03). The RA1/RA1' function will add/subtract the 17 bit synchronisation pattern and the E1, E2 and E3 bits to/from each CCITT V.110 80 bit frame as follows:

The modified CCITT V.110 36 bits frame received/sent from/to the air interface at 3.6 Kbit/s,

D1	D2	D3	S1	D4	D5	D6	X
D7	D8	D9	S3	D10	D11	D12	S4
E4	E5	E6	E7	D13	D14	D15	S6
D16	D17	D18	X	D19	D20	D21	S8
D22	D23	D24	S9				

is converted into the following a CCITT V.110 80 bits frame at 8 Kbit/s:

0	0	0	0	0	0	0	0
1	D1	D1	D2	D2	D3	D3	S1
1	D4	D4	D5	D5	D6	D6	X
1	D7	D7	D8	D8	D9	D9	S3
1	D10	D10	D11	D11	D12	D12	S4
1	E1	E2	E3	E4	E5	E6	E7
1	D13	D13	D14	D14	D15	D15	S6
1	D16	D16	D17	D17	D18	D18	X
1	D19	D19	D20	D20	D21	D21	S8
1	D22	D22	D23	D23	D24	D24	S9

For modified CCITT V.110 36 bit frames transmitted by the radio subsystem, E1, E2, E3 are discarded. For modified CCITT V.110 36 bit frames received from the radio subsystem, E1, E2, E3 are set as shown in Figure 2.

Note: The action to be taken in the case where two bits which should have the same value (e.g. bits noted D1 are received with different values is for further study.

7.4 Synchronisation

Synchronisation shall be in accordance with CCITT specification V.110, section 2.1.3.1 "Search of frame synchronisation".

On loss of synchronisation, section 2.1.3.2 of V.110, "Frame synchronisation monitoring and recovery", shall apply. In this case, idle frames with all data, status and E-bits set to binary "1" shall be sent to the air interface.

As the synchronisation process uses the V.110 frame alignment pattern only, the action is the same for Transparent and Non Transparent network support.

7.5 Idle frames

Whenever no data is received from the air interface (e.g. frame stealing applies, layer 2 fill frames are received, etc.) idle frames shall be sent. These are V.110 frames with frame alignment pattern according to CCITT rec. V.110 and all data, status and E-bits set to binary "1".

8 The RA1' Function

This function is used to adapt between the synchronous user data rates, or the output of the RA0 function and the radio interface data rates of 3.6, 6 or 12 kbit/s.

Synchronous user rate	Rate at the air interface
μ 2.4 kbit/s	3.6 kbit/s
4.8 kbit/s	6 kbit/s
9.6 kbit/s	12 kbit/s

The modified CCITT V.110 36 or 60 bit frame structures for each of the user rates is shown in figures 5-9. The meaning of the bits is described in section 5.

9 Support of Non-Transparent Bearer Services

In the case of non-transparent services, the RA1' function provides access to the 12 and 6 kbit/s (alignment of RLP frames with the four TDMA slots makes it physically impossible to provide 3.6 kbit/s) radio interface data rates.

Maximum user rate	Radio interface rate
4.8 kbit/s	6 kbit/s
9.6 kbit/s	12 kbit/s

This access results in the use of a modified CCITT V.110 60 bit frame for non-transparent services (figure 10). In this case, the RA1' function also provides for alignment of four modified CCITT V.110 60 bit frames corresponding with each complete 240 bit frame to be encoded by the radio subsystem as a single unit (see GSM 05.03). The difference between the non-transparent 60 bit frame and the 60 bit frame for the transparent service is that the bit positions used for status in a transparent frame are used to carry data (designated as D' bits in figure 10).

Note: The status bits SA, SB, and the X bit are embedded in the L2R-PDU frames (see GSM 07.01, 07.02, and 07.03).

The first bit of each RLP frame to be transmitted will correspond to the first bit (D1) of the first 60 bit frame in a four frame sequence and the last bit will correspond to the last bit (D'12) of the last 60 bit frame in a four frame sequence. Each 60 bit frame is filled from left to right starting at D1 (see figure 10).

The radio subsystem provides for the synchronous transmission and reception of 240 bit RLP frames every 20 ms (12kb/s radio interface rate) or 40 ms (6kb/s radio interface rate) irrespective of the user rate.

The request to use 6kb/s radio interface rate on a Full Rate Channel is indicated in the BC-IE by setting the NIRR bit to 6 kb/s (Negotiation procedure see GSM 07.01) and selecting a Full Rate Channel and Non-Transparent service. If the entity receiving the BC-IE is unable to support this request then the 12 kb/s radio interface rate shall be provided automatically.

Occasions may arise when there is no RLP frame ready to be transmitted. In this case a frame of 240 zeroes will be transmitted. This frame will be discarded by the distant RLP function, due to FCS failure, but will allow physical link synchronisation to be maintained between the MS and the MSC.

Octet No.	Bit number							
	1	2	3	4	5	6	7	8
0	0	0	0	0	0	0	0	0
1	1	D1	D2	D3	D4	D5	D6	S1
2	1	D7	D8	D9	D10	D11	D12	X
3	1	D13	D14	D15	D16	D17	D18	S3
4	1	D19	D20	D21	D22	D23	D24	S4
5	1	E1	E2	E3	E4	E5	E6	E7
6	1	D25	D26	D27	D28	D29	D30	S6
7	1	D31	D32	D33	D34	D35	D36	X
8	1	D37	D38	D39	D40	D41	D42	S8
9	1	D43	D44	D45	D46	D47	D48	S9

Figure 3 The CCITT V.110 80 bit RA1 frame structure

Intermediate Data Rate				
8 kbit/s	16 kbit/s	E1	E2	E3
600		1	0	0
1200		0	1	0
2400		1	1	0
4800	9600	0	1	1

Note: The 300 bit/s user data rate is carried on the 600 bit/s synchronous stream by adding stop elements, see section 2.1.

Figure 4 Coding of data rates

D1	D2	D3	D4	D5	D6	S1
D7	D8	D9	D10	D11	D12	X
D13	D14	D15	D16	D17	D18	S3
D19	D20	D21	D22	D23	D24	S4
E4	E5	E6	E7	D25	D26	D27
D28	D29	D30	S6	D31	D32	D33
D34	D35	D36	X	D37	D38	D39
D40	D41	D42	S8	D43	D44	D45
D46	D47	D48	S9			

Figure 5 Modified CCITT V.110 60 bit frame for 9.6 kbit/s transparent data

D1	D2	D3	D4	D5	D6	S1
D7	D8	D9	D10	D11	D12	X
D13	D14	D15	D16	D17	D18	S3
D19	D20	D21	D22	D23	D24	S4
E4	E5	E6	E7	D25	D26	D27
D28	D29	D30	S6	D31	D32	D33
D34	D35	D36	X	D37	D38	D39
D40	D41	D42	S8	D43	D44	D45
D46	D47	D48	S9			

Figure 6 Modified CCITT V.110 60 bit frame for 4.8. kbit/s transparent data

D1	D2	D3	S1	D4	D5	D6	X
D7	D8	D9	S3	D10	D11	D12	S4
E4	E5	E6	E7	D13	D14	D15	S6
D16	D17	D18	X	D19	D20	D21	S8
D22	D23	D24	S9				

Figure 7 Modified CCITT V.110 36 bit frame for 2.4 kbit/s transparent data

D1	D1	D2	S1	D2	D3	D3	X
D4	D4	D5	S3	D5	D6	D6	S4
E4	E5	E6	E7	D7	D7	D8	S6
D8	D9	D9	X	D10	D10	D11	S8
D11	D12	D12	S9				

Figure 8 Modified CCITT V.110 36 bit frame for 1.2 kbit/s transparent data

D1	D1	D1	S1	D1	D2	D2	X
D2	D2	D3	S3	D3	D3	D3	S4
E4	E5	E6	E7	D4	D4	D4	S6
D4	D5	D5	X	D5	D5	D6	S8
D6	D6	D6	S9				

Note: The 300 bit/s user data rate is carried on the 600 bit/s synchronous stream by adding stop elements, see section 2.1.

Figure 9 Modified CCITT V.110 36 bit frame for 600 bit/s transparent data

D1	D2	D3	D4	D5	D6	D'1
D7	D8	D9	D10	D11	D12	D'2
D13	D14	D15	D16	D17	D18	D'3
D19	D20	D21	D22	D23	D24	D'4
D'5	D'6	D'7	D'8	D25	D26	D27
D28	D29	D30	D'9	D31	D32	D33
D34	D35	D36	D'10	D37	D38	D39
D40	D41	D42	D'11	D43	D44	D45
D46	D47	D48	D'12			

Figure 10 Modified CCITT V.110 60 bit frame for non-transparent data

ANNEX (Informative) Stacks of rate adaptation

For transparent data services, the following stacks of rate adaption are possible:

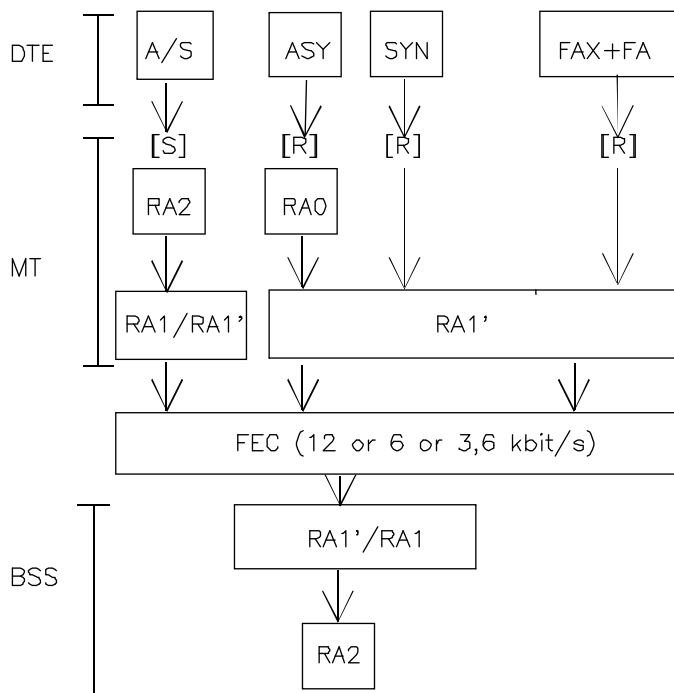

For the non-transparent services, the following stacks of rate adaption and functions are possible:

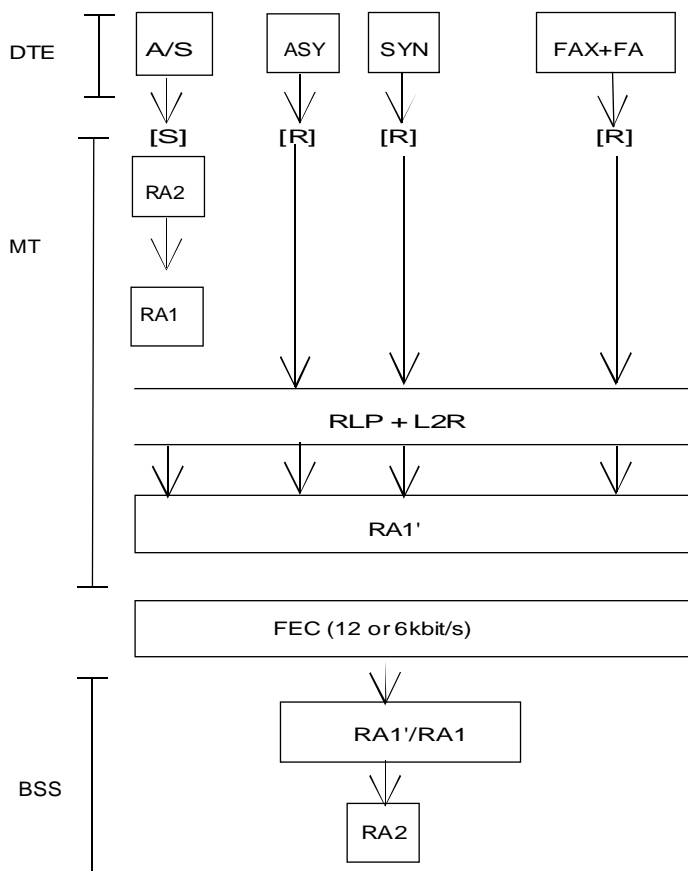

History

Document history	
September 1994	First Edition
April 1996	Converted into Adobe Acrobat Portable Document Format (PDF)