



**E**UROPEAN  
**T**ELECOMMUNICATION  
**S**TANDARD

**ETS 300 550**

September 1994

---

Source: ETSI TC-SMG

Reference: GSM 04.01

ICS: 33.060.30

**Key words:** European digital cellular telecommunications system, Global System for Mobile communications (GSM)

**European digital cellular telecommunications system (Phase 2);  
Mobile Station - Base Station System (MS - BBS) interface  
General aspects and principles  
(GSM 04.01)**

**ETSI**

European Telecommunications Standards Institute

**ETSI Secretariat**

**Postal address:** F-06921 Sophia Antipolis CEDEX - FRANCE

**Office address:** 650 Route des Lucioles - Sophia Antipolis - Valbonne - FRANCE

**X.400:** c=fr, a=atlas, p=etsi, s=secretariat - **Internet:** secretariat@etsi.fr

Tel.: +33 92 94 42 00 - Fax: +33 93 65 47 16

---

**Copyright Notification:** No part may be reproduced except as authorized by written permission. The copyright and the foregoing restriction extend to reproduction in all media.

© European Telecommunications Standards Institute 1994. All rights reserved.



## Contents

Foreword.....	5
0 General.....	7
0.1 Scope.....	7
0.2 Normative references.....	7
0.3 Definitions and abbreviations.....	8
1 General.....	8
1.1.....	8
1.2.....	8
1.3.....	8
2 Interface applications.....	8
3 Interface technical specification objectives.....	9
4 Interface characteristics.....	9
5 Interface capabilities.....	10
6 Technical Specifications on GSM MS-BSS interfaces.....	10
6.1.....	10
6.2.....	10
6.3.....	10
7 Protocol modelling principles.....	11
7.1.....	11
7.2.....	11
7.3.....	12
7.4.....	13
History.....	14

Blank page

## Foreword

This European Telecommunication Standard (ETS) has been produced by the Special Mobile Group (SMG) Technical Committee (TC) of the European Telecommunications Standards Institute (ETSI).

This ETS describes the general aspects of the Mobile Station - Base Station System (MS - BSS) interface within the European digital cellular telecommunications system (Phase 2) and correspond to GSM technical specification, GSM 04.01 version 4.0.4.

The specification from which this ETS has been derived was originally based on CEPT documentation, hence the presentation of this ETS may not be entirely in accordance with the ETSI/PNE rules.

Reference is made within this ETS to GSM Technical Specifications (GSM-TSs) (NOTE).

NOTE: TC-SMG has produced documents which give the technical specifications for the implementation of the European digital cellular telecommunications system. Historically, these documents have been identified as GSM Technical Specifications (GSM-TS). These TSs may have subsequently become I-ETSs (Phase 1), or ETSs (Phase 2), whilst others may become ETSI Technical Reports (ETRs). GSM-TSs are, for editorial reasons, still referred to in GSM ETSs.

Blank page

## 0 General

### 0.1 Scope

This Technical Specification describes the general aspects and principles relating to the Technical Specifications for the GSM MS-BSS interface.

### 0.2 Normative references

This ETS incorporates by dated and undated reference, provisions from other publications. These normative references are cited at the appropriate places in the text and the publications are listed hereafter. For dated references, subsequent amendments to or revisions of any of these publications apply to this ETS only when incorporated in it by amendment or revision. For undated references, the latest edition of the publication referred to applies.

- [1] GSM 01.04 (ETR 100): "European digital cellular telecommunications system (Phase 2); Abbreviations and acronyms".
- [2] GSM 02.30 (prETS 300 511): "European digital cellular telecommunications system (Phase 2); Man-Machine Interface (MMI) of the Mobile Station (MS)".
- [3] GSM 04.02 (prETS 300 551): "European digital cellular telecommunications system (Phase 2); GSM Public Land Mobile Network (PLMN) access reference configuration".
- [4] GSM 04.03 (prETS 300 552): "European digital cellular telecommunications system (Phase 2); Mobile Station - Base Station System (MS - BSS) interface Channel structures and access capabilities".
- [5] GSM 04.04 (prETS 300 553): "European digital cellular telecommunications system (Phase 2); layer 1 General requirements".
- [6] GSM 04.05 (prETS 300 554): "European digital cellular telecommunications system (Phase 2); Data Link (DL) layer General aspects".
- [7] GSM 04.06 (prETS 300 555): "European digital cellular telecommunications system (Phase 2); Mobile Station - Base Station System (MS - BSS) interface Data Link (DL) layer specification".
- [8] GSM 04.07 (prETS 300 556): "European digital cellular telecommunications system (Phase 2); Mobile radio interface signalling layer 3 General aspects".
- [9] GSM 04.08 (prETS 300 557): "European digital cellular telecommunications system (Phase 2); Mobile radio interface layer 3 specification".
- [10] GSM 04.10 (prETS 300 558): "European digital cellular telecommunications system (Phase 2); Mobile radio interface layer 3 Supplementary services specification General aspects".
- [11] GSM 04.11 (prETS 300 559): "European digital cellular telecommunications system (Phase 2); Point-to-Point (PP) Short Message Service (SMS) support on mobile radio interface".
- [12] GSM 04.12 (prETS 300 560): "European digital cellular telecommunications system (Phase 2); Short Message Service Cell Broadcast (SMSCB) support on the mobile radio interface".
- [13] CCITT Recommendation X.200: "Reference Model of Open Systems Interconnection for CCITT Applications".

[14] CCITT Recommendation X.210: "Open Systems Interconnection layer service definition conventions".

### 0.3 Definitions and abbreviations

Abbreviations used in this specification are listed in GSM 01.04.

## 1 General

### 1.1

A GSM PLMN supports a wide range of services which a user accesses by a standard set of interfaces at a mobile station (MS). The mobile station is connected to the PLMN fixed infrastructure via a radio path to a base station, as shown in figure 1.

### 1.2

The MS-BSS interface on this radio path is specified in the 04-series of Technical Specifications in such a way as to permit user and network technologies and configurations to evolve separately.

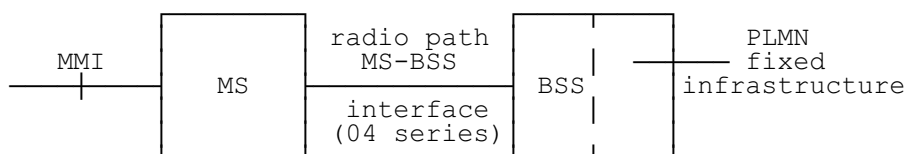

Figure 1: Basic interfaces for user access for a GSM PLMN

### 1.3

The principles and procedures for the man-machine interface (MMI) to the MS are described in Technical Specification GSM 02.30. The user may also use standard terminal interfaces within the MS. The reference configuration for the access is described in Technical Specification GSM 04.02.

## 2 Interface applications

Figure 2 shows some examples of the application of GSM MS-BSS interfaces. The following cases are shown:

- i) access of simple handportable or vehicle mounted MSs;
- ii) access of an MS with multiple terminal equipment installation;
- iii) access of a mobile PBX or LAN;

In addition, the figure identifies internetwork interfaces for connections to:

- iv) land-line ISDN networks;
- v) dedicated service networks.



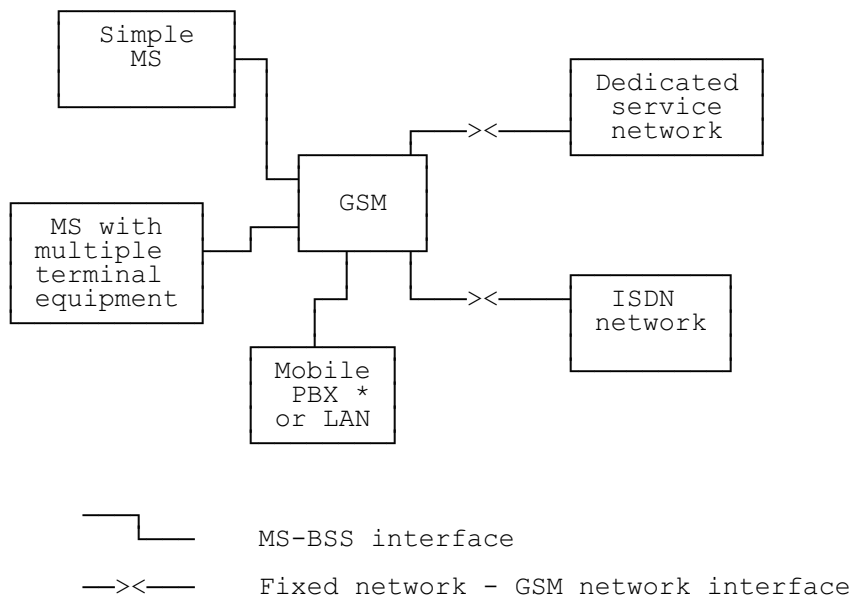

\* This case has not been specified yet.

**Figure 2: Examples of GSM interfaces**

### **3 Interface technical specification objectives**

MS-BSS interface Technical Specifications should allow:

- i) different types of mobile stations and terminal equipment to use the same standard interface;
- ii) portability of MSs within the system area of the GSM system;
- iii) separate evolution of both mobile stations and network equipment technologies and configurations;
- iv) calls to a terminal using the same code (call number) no matter in what country it is actually located;
- v) connections of an MS to the ISDN network so that only the radio channel capacity and the ISDN protocol are limiting factors.

### **4 Interface characteristics**

The MS-BSS interface is specified by a comprehensive set of characteristics, including:

- i) channel structures and access capabilities;
- ii) user-network (MS-BSS) protocols;
- iii) maintenance and operation characteristics;
- iv) performance characteristics;
- v) service characteristics.

## 5 Interface capabilities

In addition to the multiservice capability, the GSM MS-BSS interface may allow for capabilities such as the following:

- i) multidrop and other multiple terminal arrangements;
- ii) choice of information bit rate, circuit or packet switching mode, layer 2 coding method, etc..., on a call-by-call or other basis (e.g. semipermanent, or subscription time option), over the same interface according to the user's need;
- iii) capability for compatibility checking in order to check whether calling and called terminals can communicate with each other.

## 6 Technical Specifications on GSM MS-BSS interfaces

### 6.1

The reference configurations for the GSM MS-BSS interface define the terminology for various reference points. Technical Specification GSM 04.02 contains the GSM PLMN access reference configuration.

### 6.2

Technical Specification GSM 04.03 defines the channel structures and access capabilities for the MS-BSS interface. A distinction is necessary between the logical channel structure supported by the interface and the access capability supported by the radio path of the system.

### 6.3

The MS-BSS interface as defined in Technical Specifications GSM 04.04 through 04.12 is applicable to a wide range of situations.

## 7 Protocol modelling principles

### 7.1

The signalling protocols on the MS-BSS Interface are specified using the concepts of the reference model of Open System Interconnection (OSI) given in CCITT Recommendations X.200 and X.210.

### 7.2

The basic structuring technique in the OSI reference model is layering. According to this technique, communication among application processes is viewed as being logically partitioned into an ordered set of layers represented in a vertical sequence as shown in figure 3.

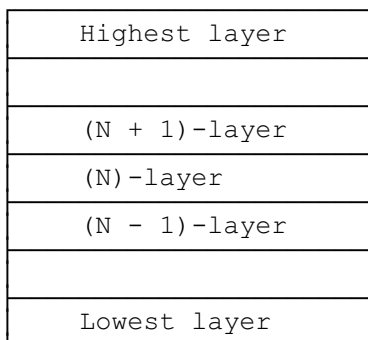

**Figure 3: Layering**

Entities exist in each layer. Entities in the same layer, but in different systems which must exchange information to achieve a common objective are called "peer entities". Entities in adjacent layers interact through their common boundary. The services provided by the (N + 1)-layer are the combination of the services and functions provided by the (N)-layer and all layers below the (N)-layer.

Management functions may also be required. They may include functions which are common for several layers and are not supported by the services provided by a specific layer. Examples of such functions are error reporting, status reporting and management of the operation of certain layers. Such management functions do not require that peer-to-peer messages are sent across the MS-BSS interface.

### 7.3

For signalling on the MS-BSS interface three layers are required as shown in figure 4.

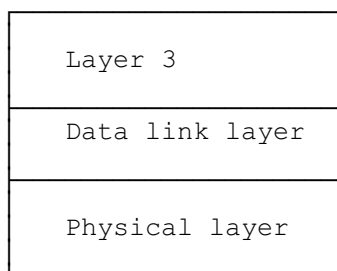

**Figure 4: Layering on the MS-BSS interface**

The layers are:

- PHYSICAL LAYER which corresponds to the lowest layer. The functions and protocols of the physical layer are defined in Technical Specification GSM 04.04.
- DATA LINK LAYER. The functions and protocols of the data link layer are defined in Technical Specifications GSM 04.05 and 04.06.
- LAYER 3. The functions and protocols of layer 3 are defined in Technical Specifications GSM 04.07, 04.08, 04.10, 04.11 and 04.12.

## 7.4

Layer-to-layer interactions are specified in terms of service primitives. The primitives represent, in an abstract way, the logical exchange of information and control between adjacent layers. They do not specify or constrain implementation.

Primitives are also used to describe information exchange between layers and the mobile management entity.

The primitives that are exchanged between the (N + 1)-layer and the (N)-layer are of the following four types (see figure 5).

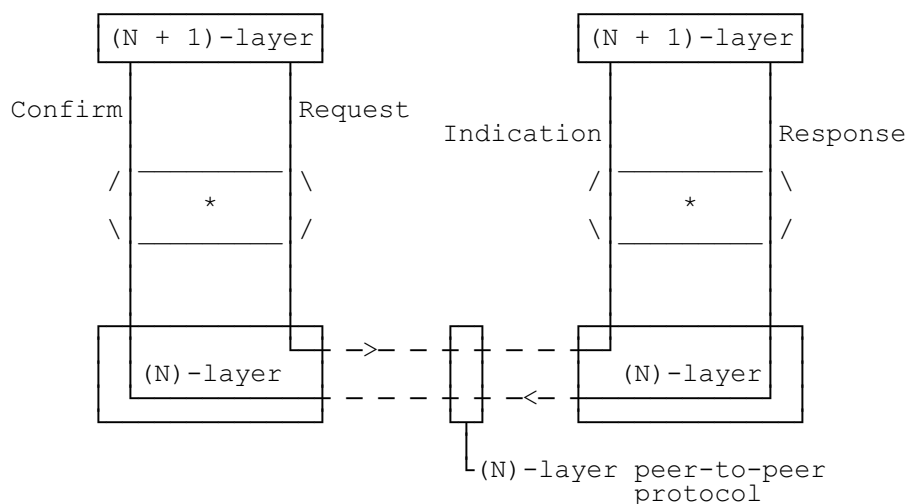

**Figure 5: Primitive action sequence for peer-to-peer communication**

The REQUEST primitive type is used when a higher layer is requesting a service from the next lower layer.

The INDICATION primitive type is used by a layer providing a service to notify the next higher layer of activities related to the primitive type REQUEST.

The RESPONSE primitive type is used by a layer to acknowledge receipt, from a lower layer, of the primitive type INDICATION.

The CONFIRM primitive type is used by the layer providing the requested service to confirm that the activity has been completed.

## History

<b>Document history</b>	
September 1994	First Edition
October 1995	Converted into Adobe Acrobat Portable Document Format (PDF)