



**E**UROPEAN  
**T**ELECOMMUNICATION  
**S**TANDARD

**ETS 300 534**

September 1994

---

Source: ETSI TC-SMG

Reference: GSM 03.20

ICS: 33.060.30

**Key words:** European digital cellular telecommunications system, Global System for Mobile communications (GSM)

**European digital cellular telecommunications system (Phase 2);  
Security related network functions  
(GSM 03.20)**

**ETSI**

European Telecommunications Standards Institute

**ETSI Secretariat**

**Postal address:** F-06921 Sophia Antipolis CEDEX - FRANCE

**Office address:** 650 Route des Lucioles - Sophia Antipolis - Valbonne - FRANCE

**X.400:** c=fr, a=atlas, p=etsi, s=secretariat - **Internet:** secretariat@etsi.fr

Tel.: +33 92 94 42 00 - Fax: +33 93 65 47 16

---

**Copyright Notification:** No part may be reproduced except as authorized by written permission. The copyright and the foregoing restriction extend to reproduction in all media.

© European Telecommunications Standards Institute 1994. All rights reserved.



## Contents

Foreword.....	5
0 Introduction.....	7
0.1 Scope .....	7
0.2 Normative references .....	7
0.3 Definitions and abbreviations.....	9
1 General.....	10
2 Subscriber identity confidentiality .....	11
2.1 Generality.....	11
2.2 Identifying method.....	11
2.3 Procedures.....	12
2.3.1 Location updating in the same MSC area .....	12
2.3.2 Location updating in a new MSCs area, within the same VLR area.....	13
2.3.3 Location updating in a new VLR; old VLR reachable.....	14
2.3.4 Location Updating in a new VLR; old VLR not reachable.....	15
2.3.5 Reallocation of a new TMSI .....	16
2.3.6 Local TMSI unknown .....	17
2.3.7 Location updating in a new VLR in case of a loss of information.....	18
2.3.8 Unsuccessful TMSI allocation .....	18
3 Subscriber identity authentication.....	19
3.1 Generality.....	19
3.2 The authentication procedure .....	19
3.3 Subscriber Authentication Key management .....	20
3.3.1 General authentication procedure .....	20
3.3.2 Authentication at location updating in a new VLR, using TMSI .....	21
3.3.3 Authentication at location updating in a new VLR, using IMSI .....	22
3.3.4 Authentication at location updating in a new VLR, using TMSI, TMSI unknown in 'old' VLR.....	23
3.3.5 Authentication at location updating in a new VLR, using TMSI, old VLR not reachable .....	24
3.3.6 Authentication with IMSI if authentication with TMSI fails .....	24
3.3.7 Re-use of security related information in failure situations.....	25
4 Confidentiality of signalling information elements, connectionless data and user information elements on physical connections .....	26
4.1 Generality.....	26
4.2 The ciphering method .....	26
4.3 Key setting .....	27
4.4 Ciphering key sequence number.....	28
4.5 Starting of the ciphering and deciphering processes.....	28
4.6 Synchronization.....	28
4.7 Handover.....	29
4.8 Negotiation of A5 algorithm .....	29
5 Synthetic summary .....	30
Annex A (informative): Security issues related to signalling schemes and key management .....	31
A.1 Introduction.....	31
A.2 Short description of the schemes.....	31

A.3	List of abbreviations.....	32
A.4	Schemes .....	33
Annex B (informative): Security information to be stored in the entities of the GSM system .....		46
B.1	Introduction.....	46
B.2	Entities and security information.....	46
B.2.1	Home Location Register (HLR).....	46
B.2.2	Visitor Location Register (VLR).....	46
B.2.3	Mobile services Switching Centre (MSC)/Base Station System (BSS).....	46
B.2.4	Mobile Station (MS).....	47
B.2.5	Authentication Centre (AuC).....	47
Annex C (normative): External specifications of security related algorithms.....		48
C.0	Scope.....	48
C.1	Specifications for Algorithm A5.....	48
C.1.1	Purpose.....	48
C.1.2	Implementation indications .....	48
C.1.3	External specifications of Algorithm A5.....	50
C.1.4	Internal specification of Algorithm A5 .....	50
C.2	Algorithm A3 .....	50
C.2.1	Purpose.....	50
C.2.2	Implementation and operational requirements .....	50
C.3	Algorithm A8 .....	51
C.3.1	Purpose.....	51
C.3.2	Implementation and operational requirements .....	51
History .....		52

## Foreword

This European Telecommunication Standard (ETS) has been produced by the Special Mobile Group (SMG) Technical Committee (TC) of the European Telecommunications Standards Institute (ETSI).

This ETS defines the security related network functions for the European digital cellular telecommunications system (Phase 2).

This ETS corresponds to GSM Technical Specification (GSM-TS) GSM 03.20 version 4.3.1.

The specification from which this ETS has been derived was originally based on CEPT documentation, hence the presentation of this ETS may not be entirely in accordance with the ETSI/PNE rules.

Reference is made within this ETS to GSM-TSs (NOTE).

Reference is also made within this ETS to GSM xx.xx. series. The specifications in the series can be identified, with their full title, within the normative reference Clause of this ETS by the first two digits of their GSM reference number e.g. GSM 09.xx series, refers to GSM 09.01, GSM 09.02, etc.

NOTE: TC-SMG has produced documents which give the technical specifications for the implementation of the European digital cellular telecommunications system. Historically, these documents have been identified as GSM Technical Specifications (GSM-TSs). These TSs may have subsequently become I-ETSs (Phase 1), or ETSs (Phase 2), whilst others may become ETSI Technical Reports (ETRs). GSM-TSs are, for editorial reasons, still referred to in GSM ETSs.

Blank page

## 0 Introduction

### 0.1 Scope

This technical specification specifies the network functions needed to provide the security related service and functions specified in technical specification GSM 02.09.

This technical specification does not address the cryptological algorithms that are needed to provide different security related features. This topic is addressed in Annex C. Wherever a cryptological algorithm or mechanism is needed, this is signalled with a reference to Annex C. The references refers only to functionalities, and some algorithms may be identical or use common hardware.

### 0.2 Normative references

This ETS incorporates by dated and undated reference, provisions from other publications. These normative references are cited at the appropriate places in the text and the publications are listed hereafter. For dated references, subsequent amendments to or revisions of any of these publications apply to this ETS only when incorporated in it by amendment or revision. For undated references, the latest edition of the publication referred to applies.

- [1] GSM 01.04 (ETR 100): "European digital cellular telecommunications system (Phase 2); "Abbreviations and acronyms".
- [2] GSM 02.09 (ETS 300 506): "European digital cellular telecommunications system (Phase 2); Security aspects".
- [3] GSM 02.17 (ETS 300 509): "European digital cellular telecommunications system (Phase 2); Subscriber identity modules Functional characteristics".
- [4] GSM 03.03 (ETS 300 523): "European digital cellular telecommunications system (Phase 2); Numbering, addressing and identification".
- [5] GSM 04.01 (ETS 300 550): "European digital cellular telecommunications system (Phase 2); Mobile Station - Base Station System (MS - BSS) interface General aspects and principles".
- [6] GSM 04.02 (ETS 300 551): "European digital cellular telecommunications system (Phase 2); GSM Public Land Mobile Network (PLMN) access reference configuration".
- [7] GSM 04.03 (ETS 300 552): "European digital cellular telecommunications system (Phase 2); Mobile Station - Base Station System (MS - BSS) interface Channel structures and access capabilities".
- [8] GSM 04.04 (ETS 300 553): "European digital cellular telecommunications system (Phase 2); layer 1 General requirements".
- [9] GSM 04.05 (ETS 300 554): "European digital cellular telecommunications system (Phase 2); Data Link (DL) layer General aspects".
- [10] GSM 04.06 (ETS 300 555): "European digital cellular telecommunications system (Phase 2); Mobile Station - Base Station System (MS - BSS) interface Data Link (DL) layer specification".
- [11] GSM 04.07 (ETS 300 556): "European digital cellular telecommunications system (Phase 2); Mobile radio interface signalling layer 3 General aspects".
- [12] GSM 04.08 (ETS 300 557): "European digital cellular telecommunications system (Phase 2); Mobile radio interface layer 3 specification".

- [13] GSM 04.10 (ETS 300 558): "European digital cellular telecommunications system (Phase 2); Mobile radio interface layer 3 Supplementary services specification General aspects".
- [14] GSM 04.11 (ETS 300 559): "European digital cellular telecommunications system (Phase 2); Point-to-Point (PP) Short Message Service (SMS) support on mobile radio interface".
- [15] GSM 04.12 (ETS 300 560): "European digital cellular telecommunications system (Phase 2); Short Message Service Cell Broadcast (SMSCB) support on the mobile radio interface".
- [16] GSM 04.13 (ETS 300 561): "European digital cellular telecommunications system (Phase 2); Performance requirements on mobile radio interface".
- [17] GSM 04.21 (ETS 300 562): "European digital cellular telecommunications system (Phase 2); Rate adaption on the Mobile Station - Base Station System (MS - BSS) interface".
- [18] GSM 04.22 (ETS 300 563): "European digital cellular telecommunications system (Phase 2); Radio Link Protocol (RLP) for data and telematic services on the Mobile Station - Base Station System (MS - BSS) interface and the Base Station System - Mobile-services Switching Centre (BSS - MSC) interface".
- [19] GSM 04.80 (ETS 300 564): "European digital cellular telecommunications system (Phase 2); Mobile radio interface layer 3 supplementary services specification Formats and coding".
- [20] GSM 04.81 (ETS 300 565): "European digital cellular telecommunications system (Phase 2); Line identification supplementary services - Stage 3".
- [21] GSM 04.82 (ETS 300 566): "European digital cellular telecommunications system (Phase 2); Call Forwarding (CF) supplementary services - Stage 3".
- [22] GSM 04.83 (ETS 300 567): "European digital cellular telecommunications system (Phase 2); Call Waiting (CW) and Call Hold (HOLD) supplementary services - Stage 3".
- [23] GSM 04.84 (ETS 300 568): "European digital cellular telecommunications system (Phase 2); Multi Party (MPTY) supplementary services - Stage 3".
- [24] GSM 04.85 (ETS 300 569): "European digital cellular telecommunications system (Phase 2); Closed User Group (CUG) supplementary services - Stage 3".
- [25] GSM 04.86 (ETS 300 570): "European digital cellular telecommunications system (Phase 2); Advice of Charge (AoC) supplementary services - Stage 3".
- [26] GSM 04.88 (ETS 300 571): "European digital cellular telecommunications system (Phase 2); Call Barring (CB) supplementary services - Stage 3".
- [27] GSM 04.90 (ETS 300 572): "European digital cellular telecommunications system (Phase 2); Unstructured supplementary services operation - Stage 3".
- [28] GSM 05.01 (ETS 300 573): "European digital cellular telecommunications system (Phase 2); Physical layer on the radio path General description".
- [29] GSM 05.02 (ETS 300 574): "European digital cellular telecommunications system (Phase 2); Multiplexing and multiple access on the radio path".



- [30] GSM 05.03 (ETS 300 575): "European digital cellular telecommunications system (Phase 2); Channel coding".
- [31] GSM 09.02 (ETS 300 599): "European digital cellular telecommunications system (Phase 2); Mobile Application Part (MAP) specification".

### **0.3 Definitions and abbreviations**

Abbreviations used in this specification are listed in GSM 01.04.

Also specific abbreviations used in Annex A are listed in section A.3.

## 1 General

The different security related services and functions that are listed in TS GSM 02.09 are grouped as follows:

- Subscriber identity confidentiality;
- Subscriber identity authentication;
- Signalling information element and connectionless user data confidentiality and data confidentiality for physical connections (ciphering).

It shall be possible to introduce new authentication and ciphering algorithms during the systems lifetime. The fixed network may support more than one authentication and ciphering algorithm.

The security procedures include mechanisms to enable recovery in event of signalling failures. These recovery procedures are designed to minimize the risk of a breach in the security of the system.

General on figures in this specification:

- In the figures below, signalling exchanges are referred to by functional names. The exact messages and message types are specified in TS GSM 04.08 and TS GSM 09.02.
- No assumptions are made for function splitting between MSC (Mobile Switching Centre), VLR (Visitor Location Register) and BSS (Base Station System). Signalling is described directly between MS and the local network (i.e. BSS, MSC and VLR denoted in the figures by BSS/MSC/VLR). The splitting in Annex A is given only for illustrative purposes.
- Addressing fields are not given; all information relates to the signalling layer. The TMSI allows addressing schemes without IMSI, but the actual implementation is specified in the GSM 04-series.
- The term HPLMN in the figures below is used as a general term which should be understood as HLR (Home Location Register) or AuC (Authentication Centre).
- What is put in a box is not part of the described procedure but it is relevant to the understanding of the figure.

## 2 Subscriber identity confidentiality

### 2.1 Generality

The purpose of this function is to avoid the possibility for an intruder to identify which subscriber is using a given resource on the radio path (e.g. TCH (Traffic Channel) or signalling resources) by listening to the signalling exchanges on the radio path. This allows both a high level of confidentiality for user data and signalling and protection against the tracing of a user's location.

The provision of this function implies that the IMSI (International Mobile Subscriber Identity), or any information allowing a listener to derive the IMSI easily, should not normally be transmitted in clear text in any signaling message on the radio path.

Consequently, to obtain the required level of protection, it is necessary that:

- a protected identifying method is normally used instead of the IMSI on the radio path; and
- the IMSI is not normally used as addressing means on the radio path (see TS GSM 02.09);
- when the signalling procedures permit it, signalling information elements that convey information about the mobile subscriber identity must be ciphered for transmission on the radio path.

The identifying method is specified in the following section. The ciphering of communication over the radio path is specified in section 4.

### 2.2 Identifying method

The means used to identify a mobile subscriber on the radio path consists of a TMSI (Temporary Mobile Subscriber Identity). This TMSI is a local number, having a meaning only in a given location area; the TMSI must be accompanied by the LAI (Location Area Identification) to avoid ambiguities. The maximum length and guidance for defining the format of a TMSI are specified in TS GSM 03.03.

The network (e.g. a VLR) manages suitable data bases to keep the relation between TMSIs and IMSIs. When a TMSI is received with an LAI that does not correspond to the current VLR, the IMSI of the MS must be requested from the VLR in charge of the indicated location area if its address is known; otherwise the IMSI is requested from the MS.

A new TMSI must be allocated at least in each location updating procedure. The allocation of a new TMSI corresponds implicitly for the MS to the de-allocation of the previous one. In the fixed part of the network, the cancellation of the record for an MS in a VLR implies the de-allocation of the corresponding TMSI.

To cope with some malfunctioning, e.g. arising from a software failure, the fixed part of the network can require the identification of the MS in clear. This procedure is a breach in the provision of the service, and should be used only when necessary.

When a new TMSI is allocated to an MS, it is transmitted to the MS in a ciphered mode. This ciphered mode is the same as defined in section 4.

The MS must store its current TMSI in a non volatile memory, together with the LAI, so that these data are not lost when the MS is switched off.

### 2.3 Procedures

This section presents the procedures, or elements of procedures, pertaining to the management of TMSIs.

#### 2.3.1 Location updating in the same MSC area

This procedure is part of the location updating procedure which takes place when the original location area and the new location area depend on the same MSC. The part of this procedure relative to TMSI management is reduced to a TMSI re-allocation (from TMSIo with "o" for "old" to TMSIn with "n" for "new").

The MS sends TMSIo as an identifying field at the beginning of the location updating procedure.

The procedure is schematised in figure 2.1.

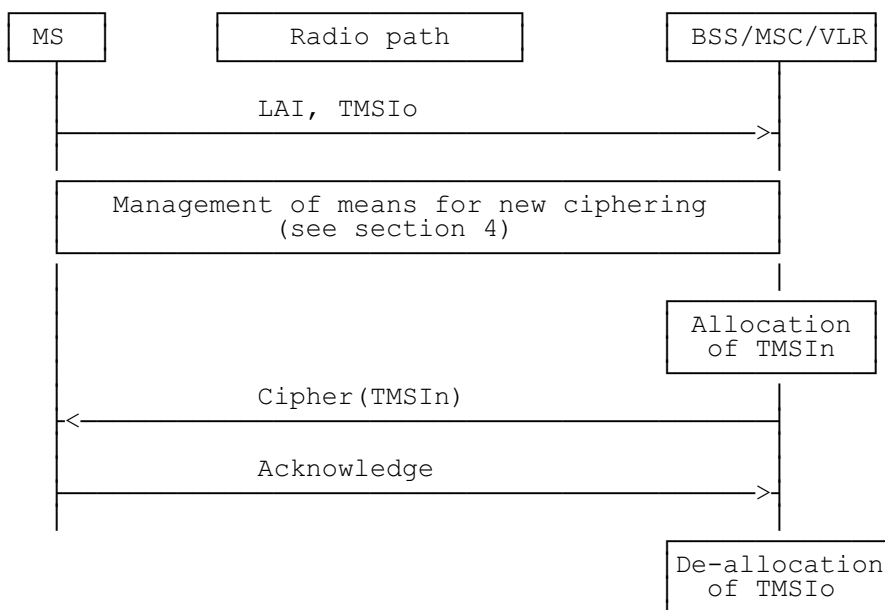

Figure 2.1: Location updating in the same MSC area

Signalling Functionalities:

Management of means for new ciphering:

The MS and BSS/MSC/VLR agree on means for ciphering signalling information elements, in particular to transmit TMSIn.

**2.3.2 Location updating in a new MSCs area, within the same VLR area**

This procedure is part of the location updating procedure which takes place when the original location area and the new location area depend on different MSCs, but on the same VLR.

The procedure is schematised on figure 2.2.

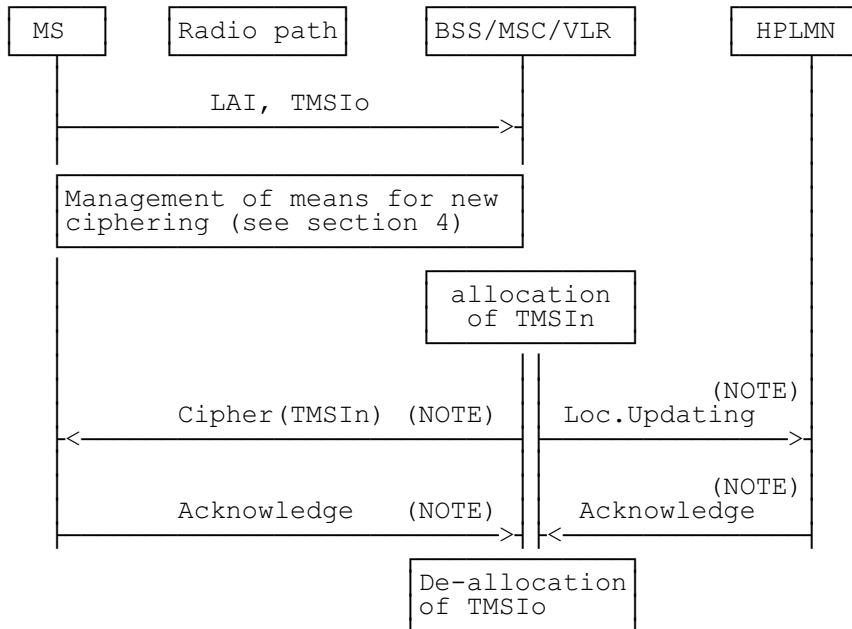

NOTE: From a security point of view, the order of the procedures is irrelevant.

**Figure 2.2: Location updating in a new MSCs area, within the same VLR area**

Signalling functionalities:

Loc.Updating:

stands for Location Updating

The BSS/MSC/VLR indicates that the location of the MS must be updated.

**2.3.3 Location updating in a new VLR; old VLR reachable**

This procedure is part of the normal location updating procedure, using TMSI and LAI, when the original location area and the new location area depend on different VLRs.

The MS is still registered in VLR<sub>o</sub> ("o" for old or original) and requests registration in VLR<sub>n</sub> ("n" for new). LAI and TMSI<sub>o</sub> are sent by MS as identifying fields during the location updating procedure.

The procedure is schematised in figure 2.3.

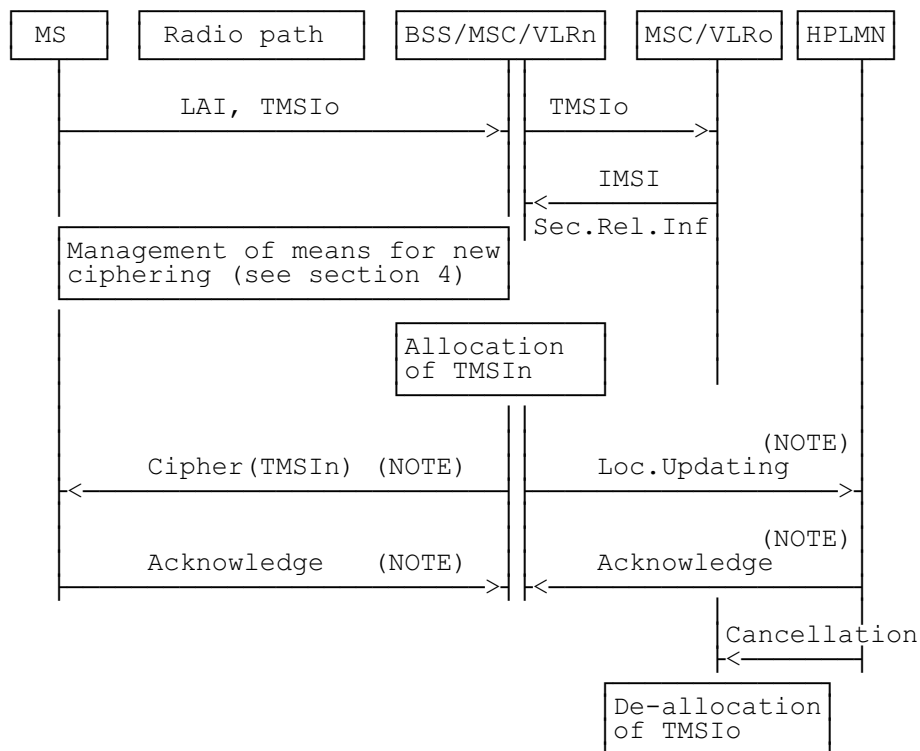

NOTE: From a security point of view, the order of the procedures is irrelevant.

**Figure 2.3: Location updating in a new VLR; old VLR reachable**

Signalling functionalities:

Sec.Rel.Info.:

Stands for Security Related information

The MSC/VLR<sub>n</sub> needs some information for authentication and ciphering; this information is obtained from MSC/VLR<sub>o</sub>.

Cancellation:

The HLR indicates to VLR<sub>o</sub> that the MS is now under control of another VLR. The "old" TMSI is free for allocation.

**2.3.4 Location Updating in a new VLR; old VLR not reachable**

This variant of the procedure in section 2.3.3 arises when the VLR receiving the LAI and TMSIo cannot identify the VLRo. In that case the relation between TMSIo and IMSI is lost, and the identification of the MS in clear is necessary.

The procedure is schematised in figure 2.4

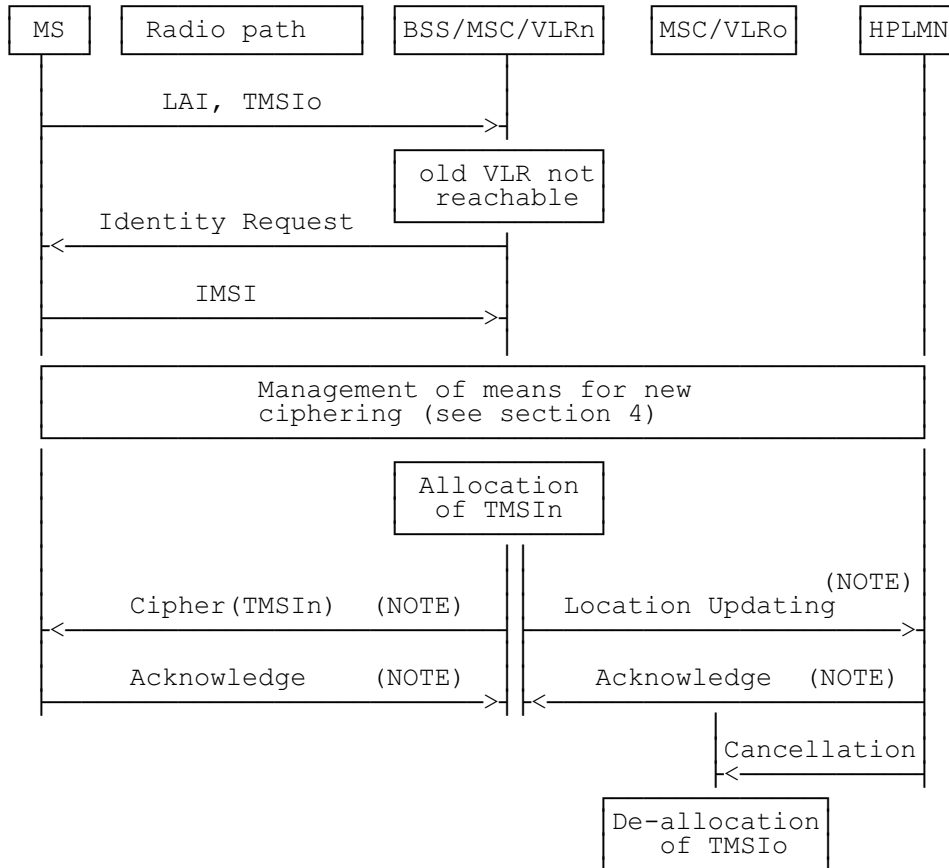

NOTE: From a security point of view, the order of the procedures is irrelevant.

**Figure 2.4: Location Updating in a new VLR; old VLR not reachable**

### 2.3.5 Reallocation of a new TMSI

This function can be initiated by the network whenever a radio connection exists. The procedure can be included in other procedures, e.g. through the means of optional parameters. The execution of this function is left to the network operator.

When a new TMSI is allocated to an MS the network must prevent the old TMSI from being allocated again until the MS has acknowledged the allocation of the new TMSI.

If an IMSI record is deleted in the VLR by O&M action, the network must prevent any TMSI associated with the deleted IMSI record from being allocated again until a new TMSI is successfully allocated to that IMSI.

If an IMSI record is deleted in the HLR by O&M action, it is not possible to prevent any TMSI associated with the IMSI record from being allocated again. However, if the MS whose IMSI record was deleted should attempt to access the network using the TMSI after the TMSI has been allocated to a different IMSI, then authentication or ciphering of the MS whose IMSI was deleted will almost certainly fail, which will cause the TMSI to be deleted from the MS.

The case where allocation of a new TMSI is unsuccessful is described in section 2.3.8.

This procedure is schematised in figure 2.5.

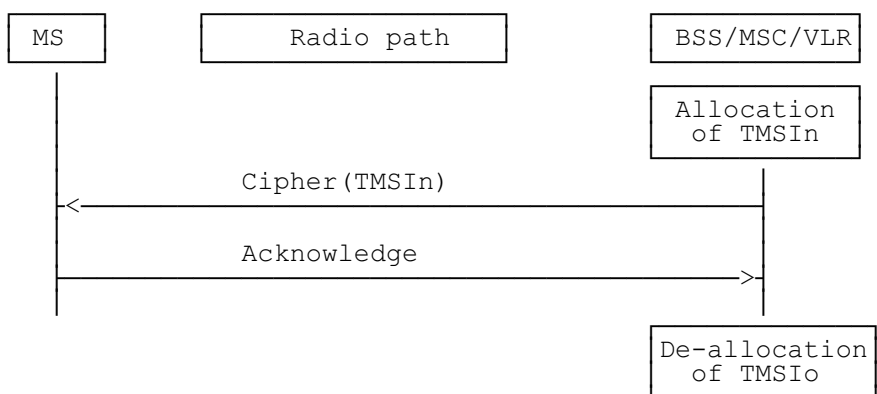

Figure 2.5: Reallocation of a new TMSI



### 2.3.6 Local TMSI unknown

This procedure is a variant of the procedure described in sections 2.3.1 and 2.3.2, and happens when a data loss has occurred in a VLR and when a MS uses an unknown TMSI, e.g. for a communication request or for a location updating request in a location area managed by the same VLR.

This procedure is schematised in figure 2.6.

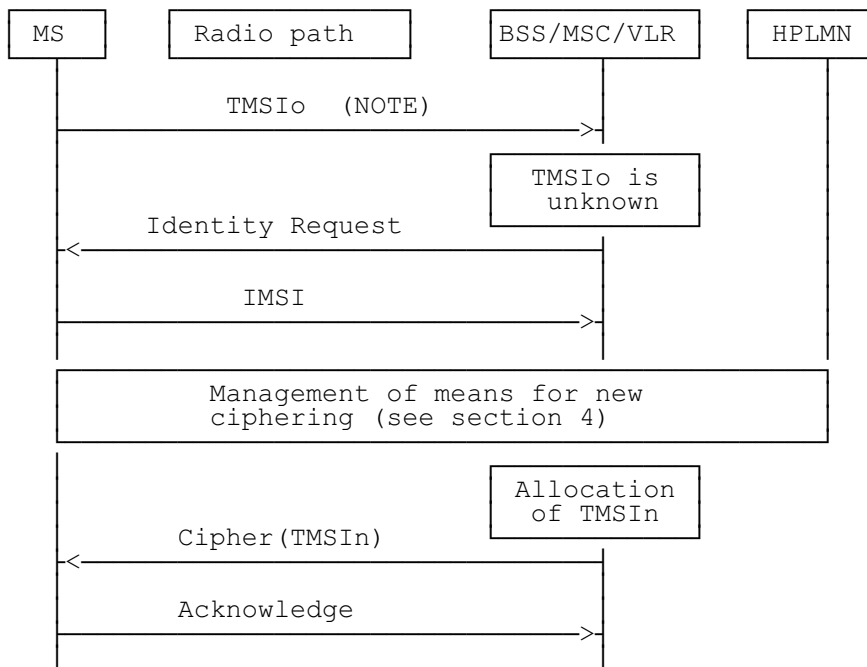

NOTE: Any message in which TMSIo is used as an identifying means in a location area managed by the same VLR.

**Figure 2.6: Location updating in the same MSC area; local TMSI unknown**

### 2.3.7 Location updating in a new VLR in case of a loss of information

This variant of the procedure described in 2.3.3 arises when the VLR in charge of the MS has suffered a loss of data. In that case the relation between TMSI<sub>o</sub> and IMSI is lost, and the identification of the MS in clear is necessary.

The procedure is schematised in figure 2.7.

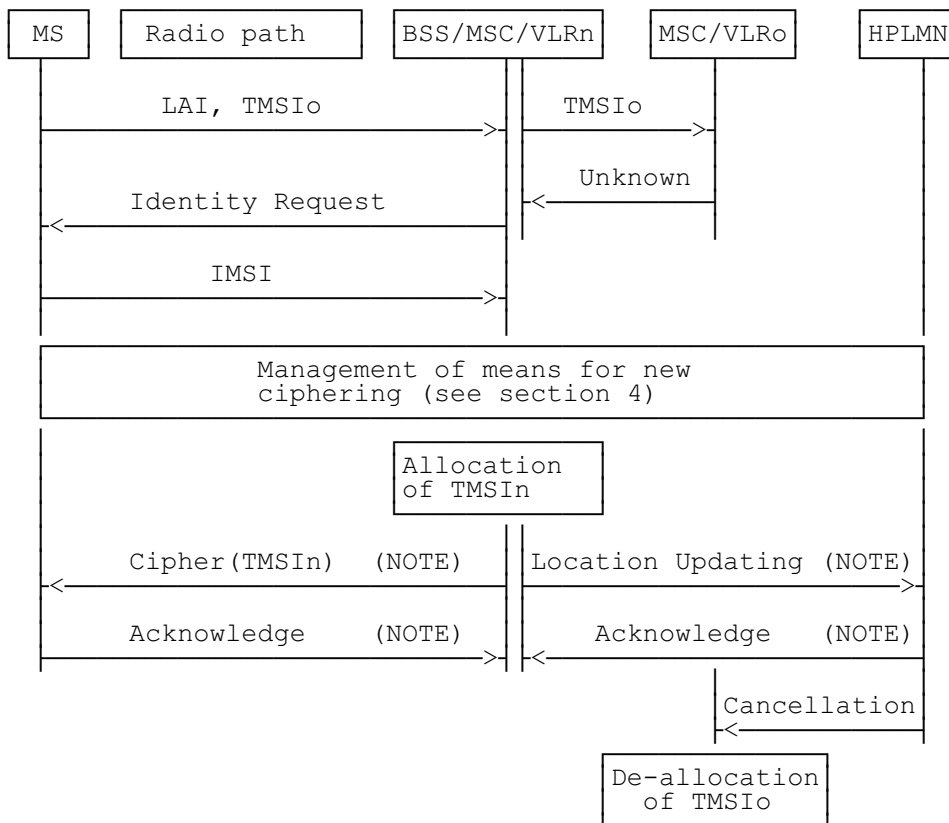

NOTE: From a security point of view, the order of the procedures is irrelevant.

**Figure 2.7: Location updating in a new VLR in case of a loss of information**

### 2.3.8 Unsuccessful TMSI allocation

If the MS does not acknowledge the allocation of a new TMSI, the network shall maintain the association between the old TMSI and the IMSI and between the new TMSI and the IMSI.

For an MS-originated transaction, the network shall allow the MS to identify itself by either the old TMSI or the new TMSI. This will allow the network to determine the TMSI stored in the MS; the association between the other TMSI and the IMSI shall then be deleted, to allow the unused TMSI to be allocated to another MS.

For a network-originated transaction, the network shall identify the MS by its IMSI. When radio contact has been established, the network shall instruct the MS to delete any stored TMSI. When the MS has acknowledged this instruction, the network shall delete the association between the IMSI of the MS and any TMSI; this will allow the released TMSIs to be allocated to another MS.

In either of the cases above, the network may initiate the normal TMSI reallocation procedure.

Repeated failure of TMSI reallocation (passing a limit set by the operator) may be reported for O&M action.

### 3 Subscriber identity authentication

#### 3.1 Generality

The definition and operational requirements of subscriber identity authentication are given in TS GSM 02.09.

The authentication procedure will also be used to set the ciphering key (see section 4). Therefore, it is performed after the subscriber identity (TMSI/IMSI) is known by the network and before the channel is encrypted.

Two network functions are necessary: the authentication procedure itself, and the key management inside the fixed subsystem.

#### 3.2 The authentication procedure

The authentication procedure consists of the following exchange between the fixed subsystem and the MS.

- The fixed subsystem transmits a non-predictable number RAND to the MS.
- The MS computes the signature of RAND, say SRES, using algorithm A3 and some secret information: the Individual Subscriber Authentication Key, denoted below by  $K_i$ .
- The MS transmits the signature SRES to the fixed subsystem.
- The fixed subsystem tests SRES for validity.

The general procedure is schematised in figure 3.1.

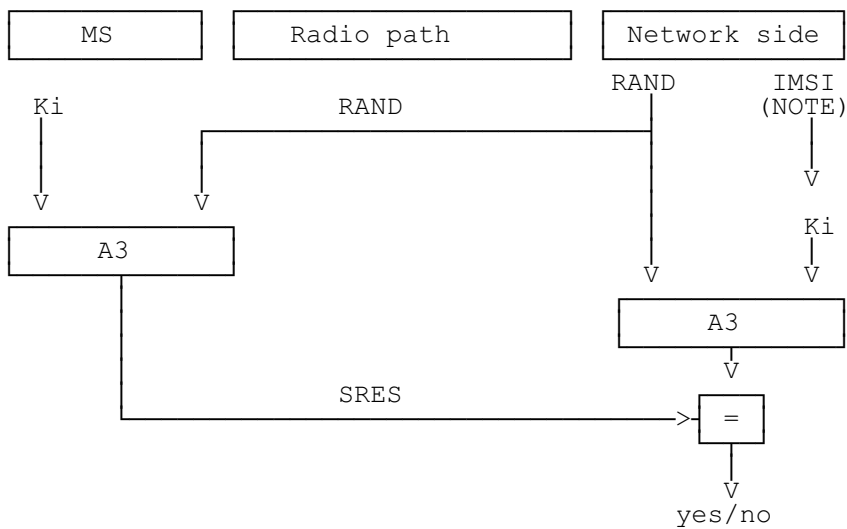

NOTE: IMSI is used to retrieve  $K_i$  in the network.

**Figure 3.1: The authentication procedure**

Authentication algorithm A3 is specified in Annex C.

### 3.3 Subscriber Authentication Key management

The Subscriber Authentication Key  $K_i$  is allocated, together with the IMSI, at subscription time.

$K_i$  is stored on the network side in the Home Public Land Mobile Network (HPLMN), in an Authentication Centre (AuC). A PLMN may contain one or more AuC. An AuC can be physically integrated with other functions, e.g. in a Home Location Register (HLR).

#### 3.3.1 General authentication procedure

When needed for each MS, the BSS/MSC/VLR requests security related information from the HLR/AuC corresponding to the MS. This includes an array of pairs of corresponding RAND and SRES. These pairs are obtained by applying Algorithm A3 to each RAND and the key  $K_i$  as shown in figure 3.1. The pairs are stored in the VLR as part of the security related information.

The procedure used for updating the vectors RAND/SRES is schematised in figure 3.2.

NOTE: The Authentication Vector Response contains also  $K_c(1..n)$  which is not shown in this and the following figures. For discussion of  $K_c$  see section 4.

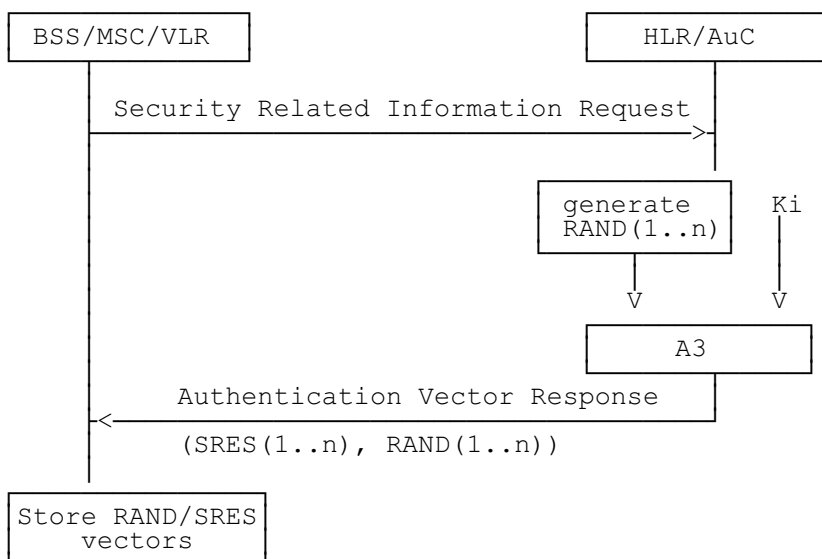

Figure 3.2: Procedure for updating the vectors RAND/SRES

When an MSC/VLR performs an authentication, including the case of a location updating within the same VLR area, it chooses a RAND value in the array corresponding to the MS. It then tests the answer from the MS by comparing it with the corresponding SRES, as schematised in figure 3.3.

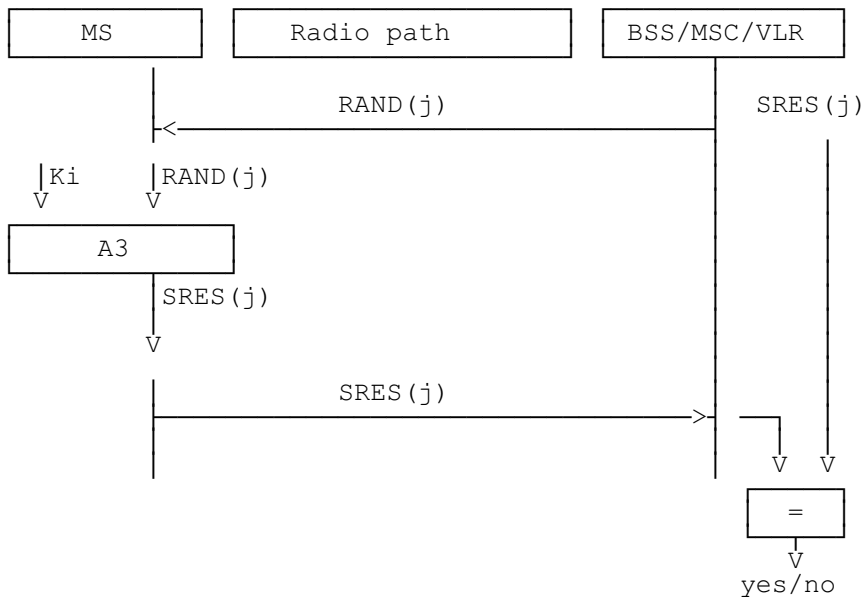

Figure 3.3: General authentication procedure

3.3.2 Authentication at location updating in a new VLR, using TMSI

During location updating in a new VLR (VLRn), the procedure to get pairs for subsequent authentication may differ from that described in the previous section. In the case when identification is done using TMSI, pairs for authentication as part of security related information are given by the old VLR (VLRo). The old VLR shall send to the new VLR only those pairs which have not been used.

The procedure is schematised in figure 3.4.

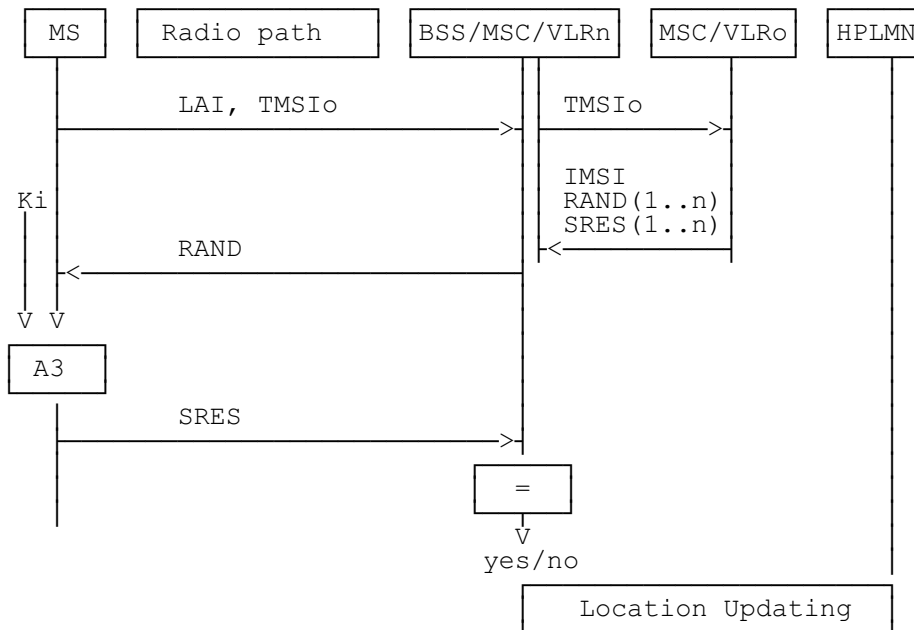

Figure 3.4: Authentication at location updating in a new VLR, using TMSI

### 3.3.3 Authentication at location updating in a new VLR, using IMSI

When the IMSI is used for identification, or more generally when the old VLR is not reachable, the procedure described in section 3.3.2 cannot be used. Instead, pairs of RAND/SRES contained in the security related information are requested directly from the HPLMN.

The procedure is schematised in figure 3.5.

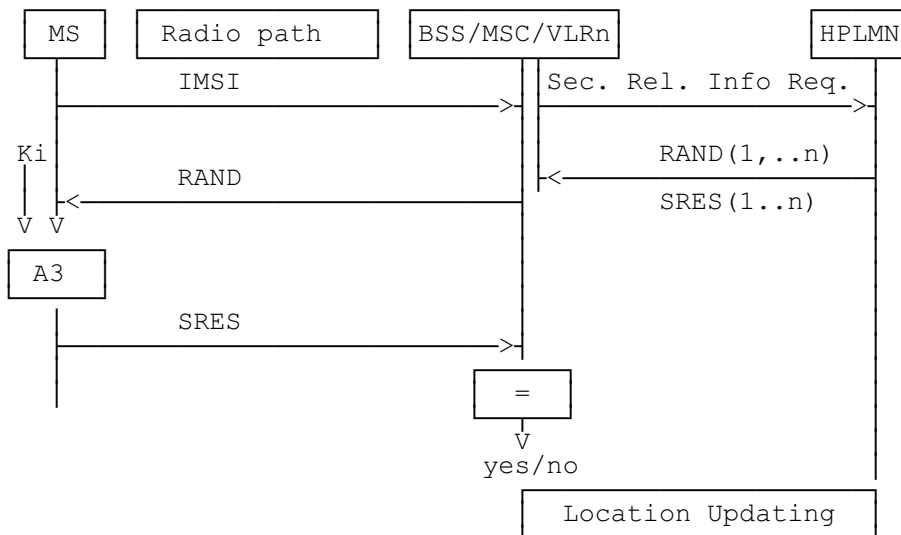
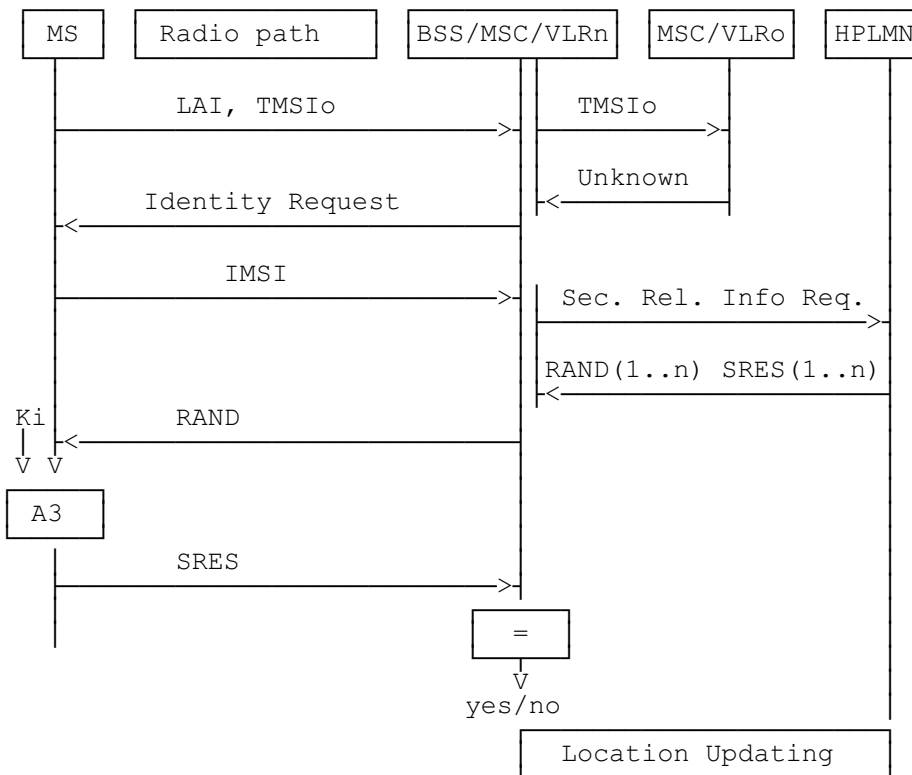

Figure 3.5: Authentication at location updating in a new VLR, using IMSI

**3.3.4 Authentication at location updating in a new VLR, using TMSI, TMSI unknown in 'old' VLR**

This case is an abnormal one, when a data loss has occurred in the 'old' VLR.

The procedure is schematised in figure 3.6.

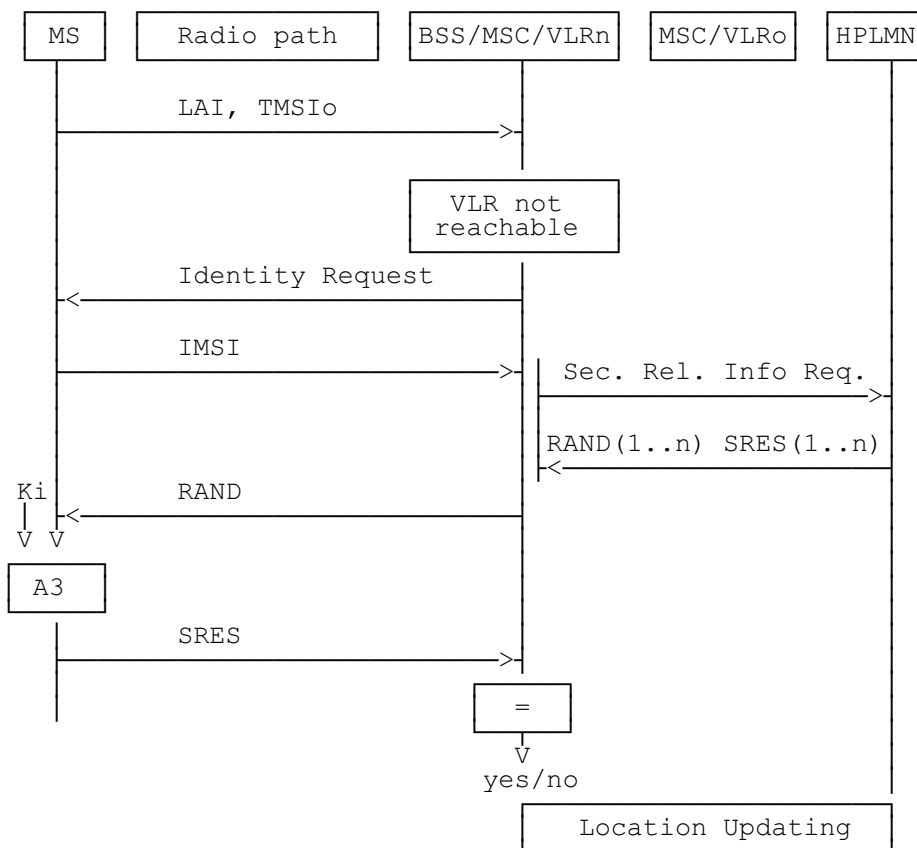

**Figure 3.6: Authentication at location updating in a new VLR, using TMSI, TMSI unknown in 'old' VLR**

**3.3.5 Authentication at location updating in a new VLR, using TMSI, old VLR not reachable**

The case occurs when an old VLR cannot be reached by the new VLR.

The procedure is schematised in figure 3.7



**Figure 3.7: Authentication at location updating in a new VLR, using TMSI, old VLR not reachable**

**3.3.6 Authentication with IMSI if authentication with TMSI fails**

If authentication of an MS which identifies itself with a TMSI is unsuccessful, the network requests the IMSI from the MS, and repeats the authentication using the IMSI. Optionally, if authentication using the TMSI fails the network may reject the access request or location registration request which triggered the authentication.



### 3.3.7 Re-use of security related information in failure situations

Security related information consisting of sets of RAND, SRES and Kc is stored in the VLR and in the HLR.

When a VLR has used a set of security related information to authenticate an MS, it shall delete the set of security related information or mark it as used. When a VLR needs to use security related information, it shall use a set which is not marked as used in preference to a set which is marked as used; if there are no sets which are not marked as used then the VLR may use a set which is marked as used. It is an operator option to define how many times a set of security related information may be re-used in the VLR; when a set of security related information has been re-used as many times as is permitted by the operator, it shall be deleted.

If a VLR successfully requests security related information from the HLR, it shall discard any security related information which is marked as used in the VLR.

If a VLR receives from another VLR a request for security related information, it shall send only the sets which are not marked as used.

If an HLR receives a request for security related information, it shall send any sets which are not marked as used; those sets shall then be deleted or marked as used. If there are no sets which are not marked as used, the HLR may as an operator option send sets which are marked as used. It is an operator option to define how many times a set of security related information may be re-sent by the HLR; when a set of security related information has been sent as many times as is permitted by the operator, it shall be deleted.

## **4 Confidentiality of signalling information elements, connectionless data and user information elements on physical connections**

### **4.1 Generality**

In TS GSM 02.09, some signalling information elements are considered sensitive and must be protected.

To ensure identity confidentiality (see section 2), the Temporary Subscriber Identity must be transferred in a protected mode at allocation time and at other times when the signalling procedures permit it.

The confidentiality of connection less user data requires at least the protection of the message part pertaining to OSI layers 4 and above.

The user information confidentiality of user information on physical connections concerns the information transmitted on a traffic channel on the MS-BSS interface (e.g. for speech). It is not an end-to-end confidentiality service.

These needs for a protected mode of transmission are fulfilled with the same mechanism where the confidentiality function is a OSI layer 1 function. The scheme described below assumes that the main part of the signalling information elements is transmitted on DCCH (Dedicated Control Channel), and that the CCCH (Common Control Channel) is only used for the allocation of a DCCH.

Four points have to be specified:

- the ciphering method;
- the key setting;
- the starting of the enciphering and deciphering processes;
- the synchronization.

### **4.2 The ciphering method**

The layer 1 data flow (transmitted on DCCH or TCH) is ciphered by a bit per bit or stream cipher, i.e. the data flow on the radio path is obtained by the bit per bit binary addition of the user data flow and a ciphering bit stream, generated by algorithm A5 using a key determined as specified in section 4.3. The key is denoted below by Kc, and is called "Ciphering Key".

Deciphering is performed by exactly the same method.

Algorithm A5 is specified in Annex C.

### 4.3 Key setting

Mutual key setting is the procedure that allows the mobile station and the network to agree on the key  $K_c$  to use in the ciphering and deciphering algorithms A5.

A key setting is triggered by the authentication procedure. Key setting may be initiated by the network as often as the network operator wishes.

Key setting must occur on a DCCH not yet encrypted and as soon as the identity of the mobile subscriber (i.e. TMSI or IMSI) is known by the network.

The transmission of  $K_c$  to the MS is indirect and uses the authentication RAND value;  $K_c$  is derived from RAND by using algorithm A8 and the Subscriber Authentication key  $K_i$ , as defined in Annex C.

As a consequence, the procedures for the management of  $K_c$  are the authentication procedures described in section 3.3.

The values  $K_c$  are computed together with the SRES values. The security related information (see section 3.3.1) consists of RAND, SRES and  $K_c$ .

The key  $K_c$  is stored by the mobile station until it is updated at the next authentication.

Key setting is schematized in figure 4.1.

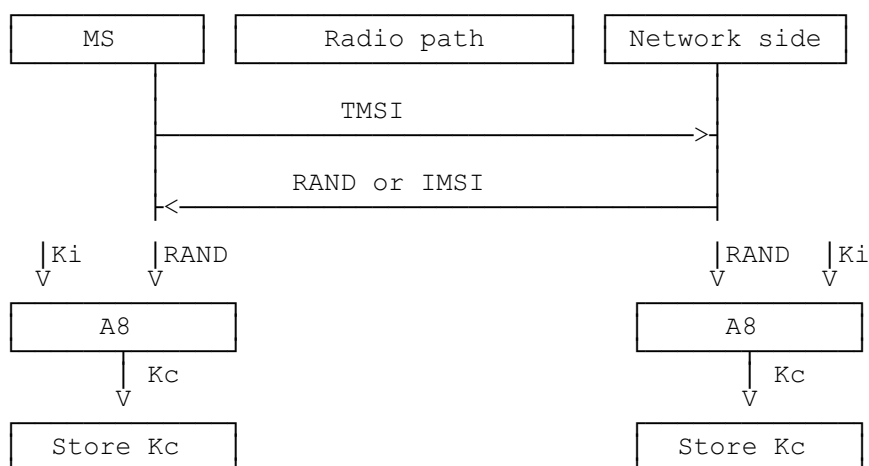

Figure 4.1: Key setting

#### 4.4 Cipherring key sequence number

The cipherring key sequence number is a number which is associated with the cipherring key  $K_c$  and they are stored together in the mobile station and in the network.

However since it is not directly involved in any security mechanism, it is not addressed in this technical specification but in TS GSM 04.08 instead.

#### 4.5 Starting of the cipherring and deciphering processes

The MS and the BSS must coordinate the instants at which the enciphering and deciphering processes start on DCCH and TCH.

On DCCH, this procedure takes place under the control of the network some time after the completion of the authentication procedure (if any), or after the key  $K_c$  has been made available at the BSS.

No information elements for which protection is needed must be sent before the cipherring and deciphering processes are operating.

The transition from clear text mode to ciphered mode proceeds as follows: deciphering starts in the BSS, which sends in clear text to the MS a specific message, here called "Start cipher". Both the enciphering and deciphering start on the MS side after the message "Start cipher" has been correctly received by the MS. Finally, enciphering on the BSS side starts as soon as a frame or a message from the MS has been correctly deciphered at the BSS.

The starting of enciphering and deciphering processes is schematised in figure 4.2.

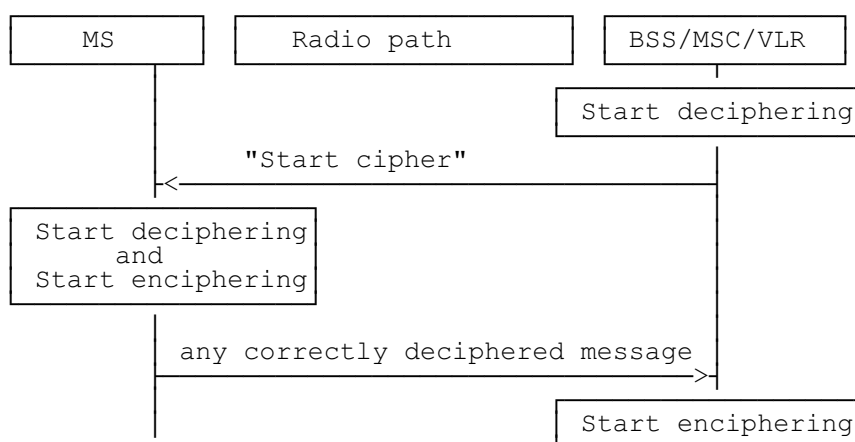

Figure 4.2: Starting of the enciphering and deciphering processes

When a TCH is allocated for user data transmission, the key used is the one set during the preceding DCCH session (Call Set-up). The enciphering and deciphering processes start immediately.

#### 4.6 Synchronization

The enciphering stream at one end and the deciphering stream at the other end must be synchronised, for the enciphering bit stream and the deciphering bit streams to coincide. The underlying Synchronization scheme is described in Annex C.

#### 4.7 Handover

When a handover occurs, the necessary information (e.g. key Kc, initialization data) is transmitted within the system infrastructure to enable the communication to proceed from the old BSS to the new one, and the Synchronization procedure is resumed. The key Kc remains unchanged at handover.

#### 4.8 Negotiation of A5 algorithm

Not more than seven versions of the A5 algorithm will be defined.

When an MS wishes to establish a connection with the network, the MS shall indicate to the network which of the seven versions of the A5 algorithm it supports.

The network shall compare its ciphering capabilities and preferences, and any special requirements of the subscription of the MS, with those indicated by the MS and act according to the following rules:

- 1) If the MS and the network have no versions of the A5 algorithm in common and the network is not prepared to use an unciphered connection, then the connection shall be released.
- 2) If the MS and the network have at least one version of the A5 algorithm in common, then the network shall select one of the mutually acceptable versions of the A5 algorithm for use on that connection.
- 3) If the MS and the network have no versions of the A5 algorithm in common and the network is willing to use an unciphered connection, then an unciphered connection shall be used.

## 5 Synthetic summary

Figure 5.1 shows in a synopsis a normal location updating procedure with all elements pertaining to security functions, i.e. to TMSI management, authentication and Kc management.

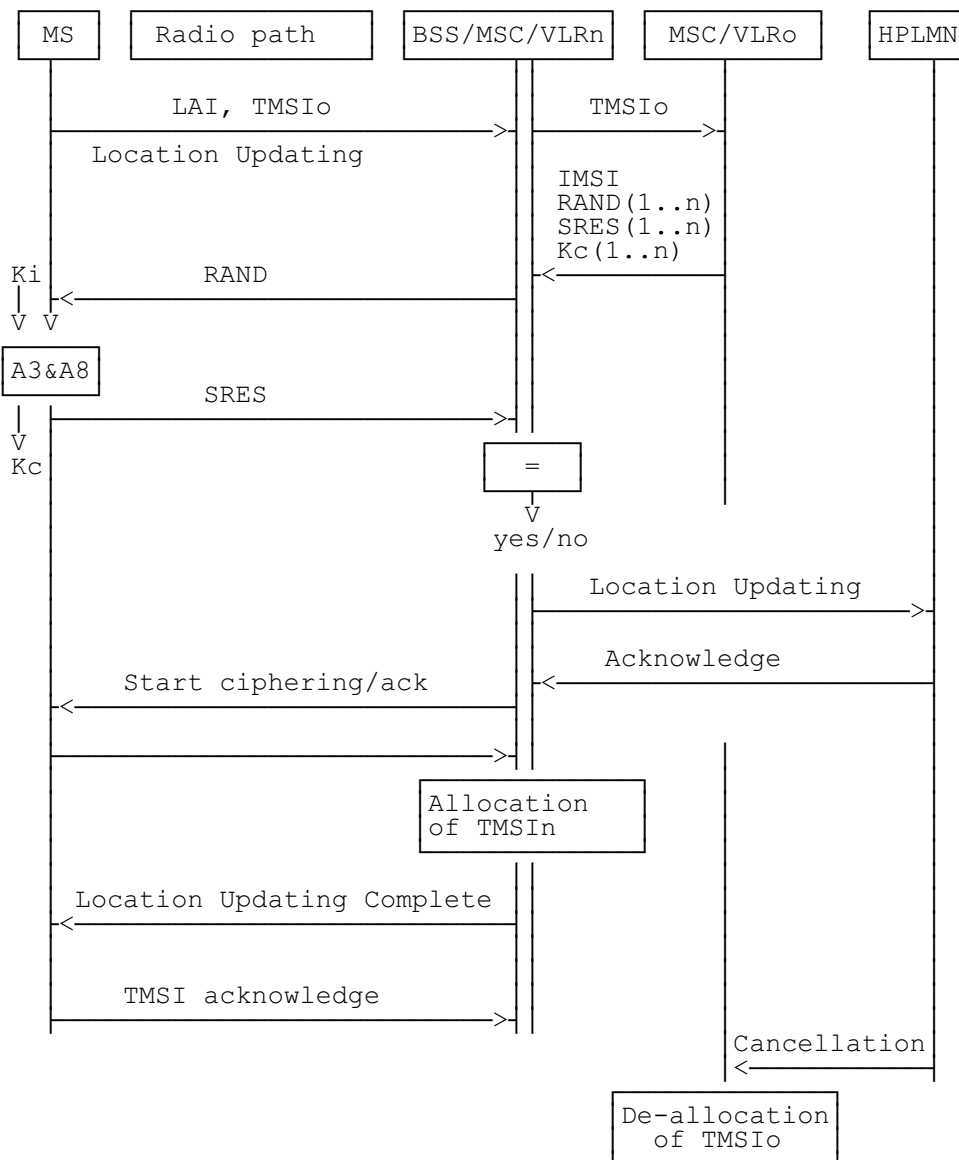

Figure 5.1: Normal location updating procedure

## **Annex A (informative): Security issues related to signalling schemes and key management**

### **A.1 Introduction**

The diagrams in this annex indicate the security items related to signalling functions and to some of the key management functions. The purpose of the diagrams is to give a general overview of signalling, both on the radio path and in the fixed network. The diagrams indicate how and where keys are generated, distributed, stored and used. The security functions are split between VLR and BSS/MSC.

### **A.2 Short description of the schemes**

Scheme 1: Location registration

- no TMSI available.

The situation occurs where an MS requests registration and for some reason e.g. TMSI is lost or this is the first registration, there is no TMSI available. In this case the IMSI is used for identification. The IMSI is sent in clear text via the radio path as part of the location updating.

Scheme 2: Location updating

- MS registered in VLR;
- TMSI is still available.

The mobile station stays within the area controlled by the VLR. The mobile station is already registered in this VLR. All information belonging to the mobile station is stored in the VLR, so no connection with the HLR is necessary. Identification is done by the CKSN, LAI and TMSI. For authentication a new set of RAND, SRES and Kc is already available in the VLR.

Scheme 3: Location updating

- MS not yet registered in VLR;
- TMSI is still available.

The MS has roamed to an area controlled by another VLR. The LAI is used to address the "old" VLR. The TMSI is used for identification. The "old" VLR informs the "new" VLR about this MS. The security related information is sent by the "old" VLR to the "new" VLR.

Scheme 4: Location updating

- MS not yet registered in VLR and no old LAI.

The VLR cannot identify the VLR where the MS was last registered. Identification is therefore done by using the IMSI. The VLR cannot request authentication information from the previous VLR (LAI not available), so the HLR has to send the authentication information to the VLR.

Scheme 5: Call set-up

- mobile originated;
- early assignment.

The users of the registered MS wants to set-up a call. Identification is done by using the TMSI. All signalling information elements in all messages on the radio path are encrypted with ciphering key Kc. The PLMN is setting up calls with "early assignment".

Scheme 6: Call set-up

- mobile originated;
- off air call set-up.

As in scheme 5 the user of the registered MS wants to set-up a call. Identification is done by using the TMSI. All signalling information elements in all messages on the radio path are encrypted with ciphering key Kc after the cipher mode command message. The PLMN is setting up calls with "off air call set-up"

Scheme 7: Call set-up

- mobile terminated;
- early assignment.

A paging request is sent to the registered MS, addressed by the TMSI. All signalling information elements in all messages on the radio path are encrypted with ciphering key Kc after the cipher mode command message. The PLMN is setting up calls with "early assignment".

### A.3 List of abbreviations

In addition to the abbreviations listed in TS GSM 01.04 the following abbreviations are used in the schemes:

A3	authentication algorithm
A5	signalling data and user data encryption algorithm
A8	ciphering key generating algorithm
BSS	Base Station System
HLR	Home Location Register
IMSI	International Mobile Subscriber Identity
Kc	ciphering key
Kc[M]	message encrypted with ciphering key Kc
Kc[TMSI]	TMSI encrypted with ciphering key Kc
Ki	individual subscriber authentication key
LAI	Location Area Identity
MS	Mobile Station
MSC	Mobile services Switching Centre
R	Random number (RAND)
S	Signed response (SRES)
TMSI o/n	Temporary Mobile Subscriber Identity old/new
VLR o/n	Visitor Location Register old/new



**A.4 Schemes**

**Scheme 1:**

Location registration  
 - no TMSI available

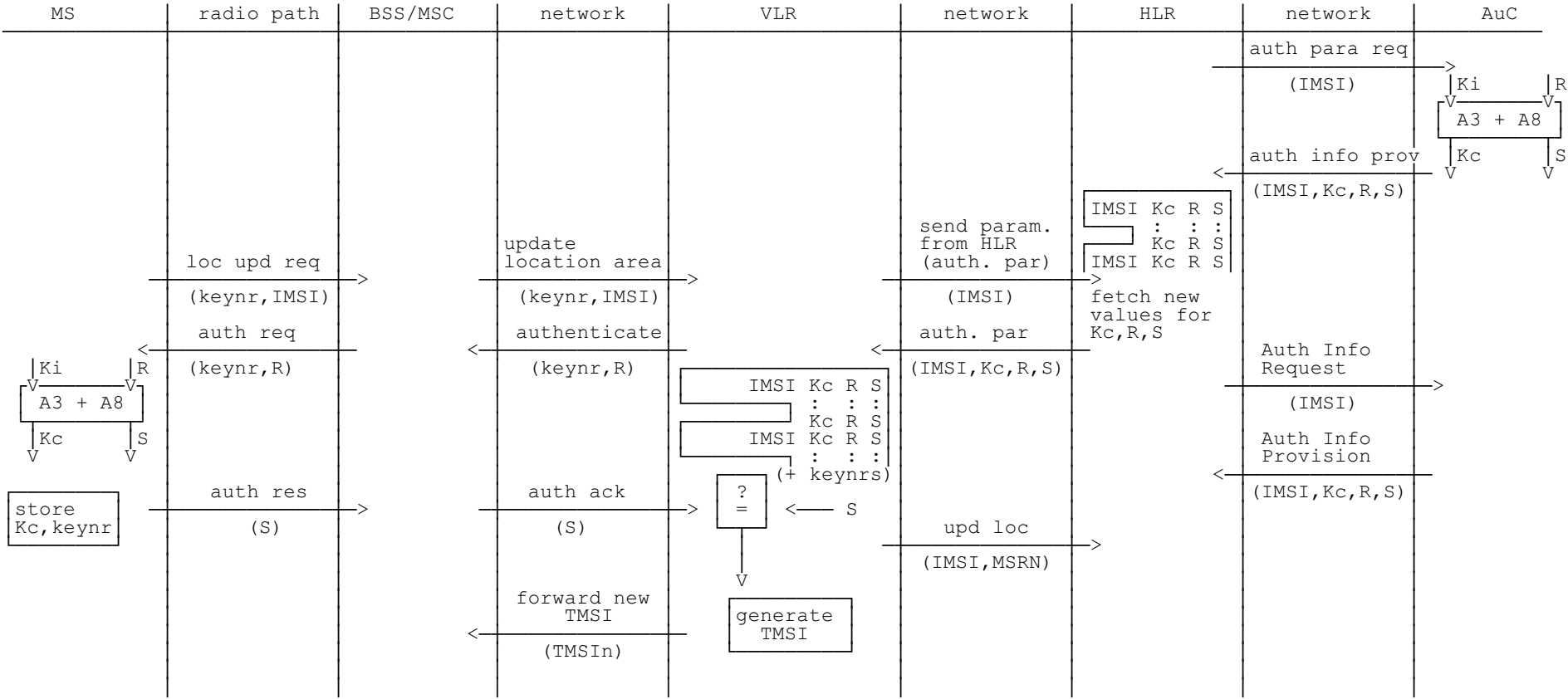

**Scheme 1 (concluded):**

Location registration  
 - no TMSI available

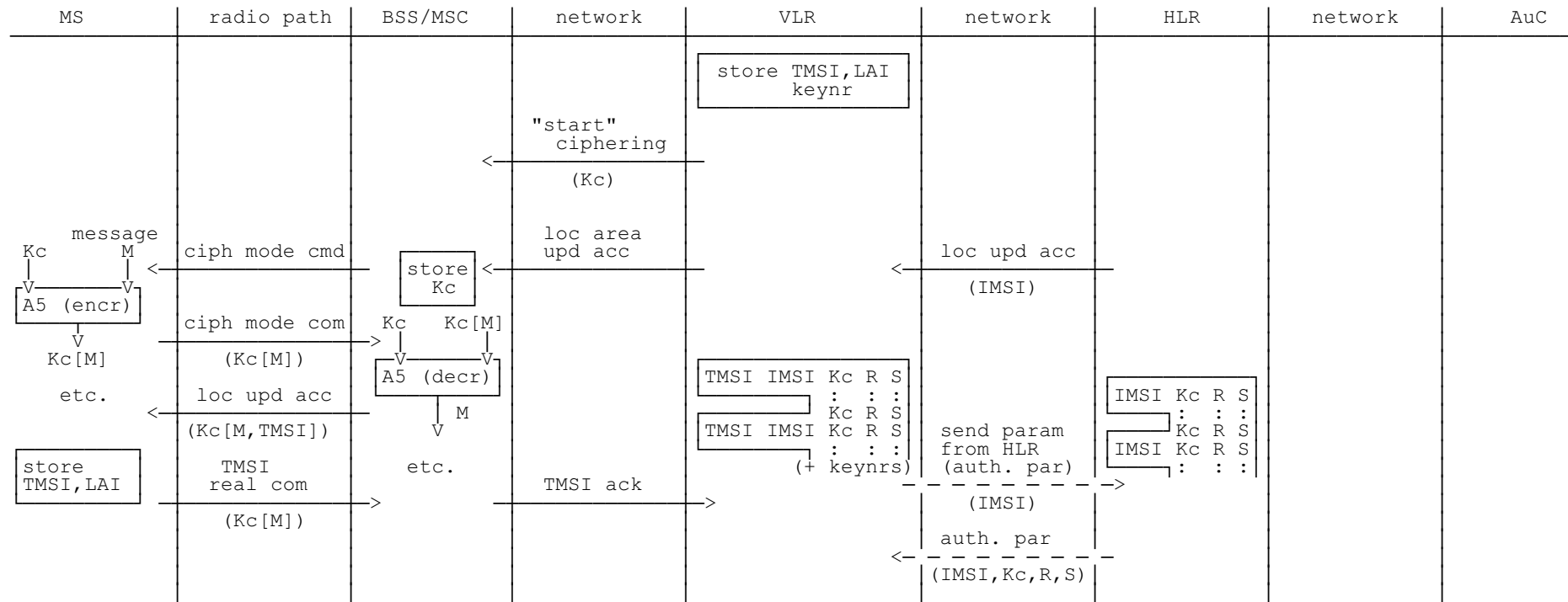

**Scheme 2:**

Location updating

- MS registered in VLR
- TMSI is still available

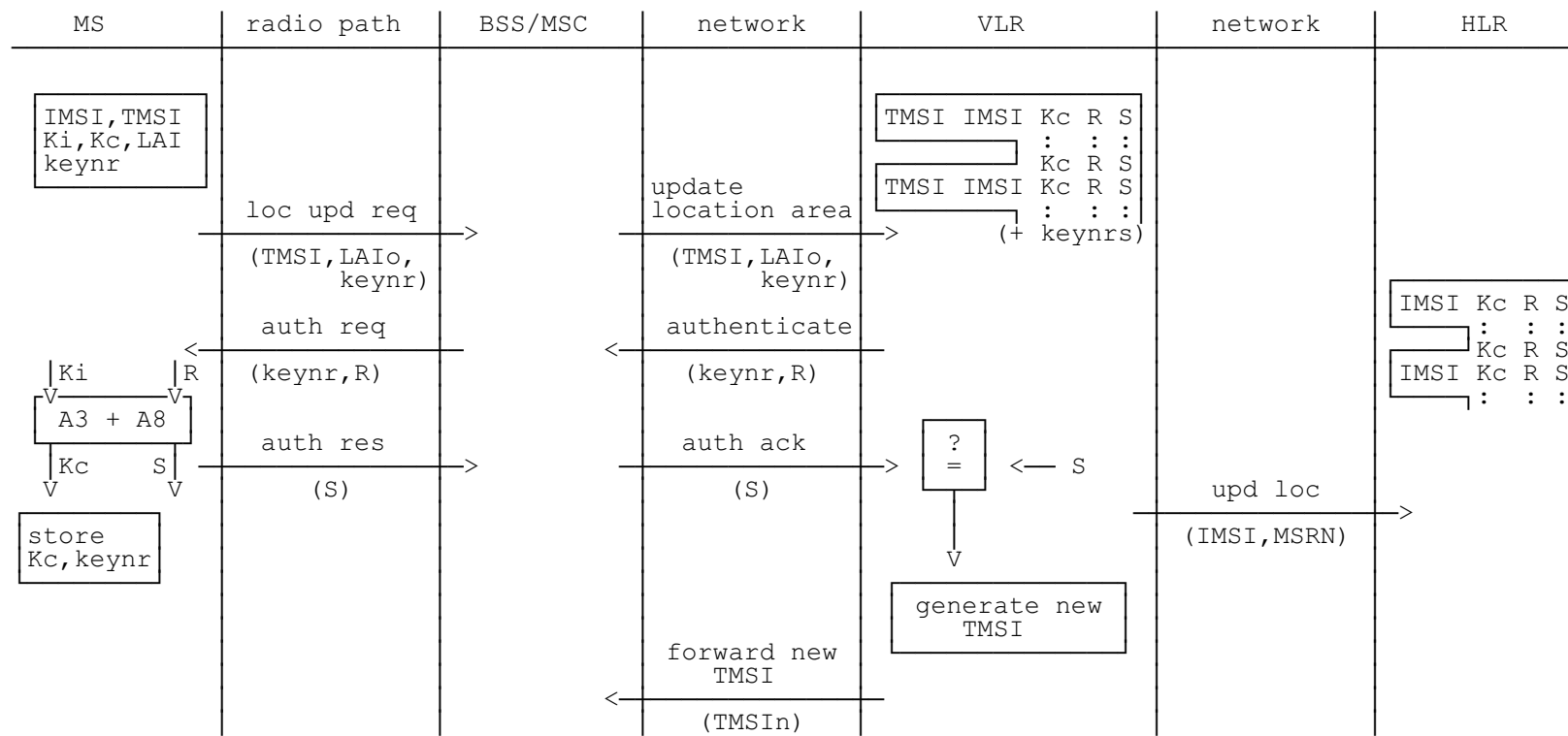

**Scheme 2 (concluded):**

Location registration

- MS registered in VLR
- TMSI is still available

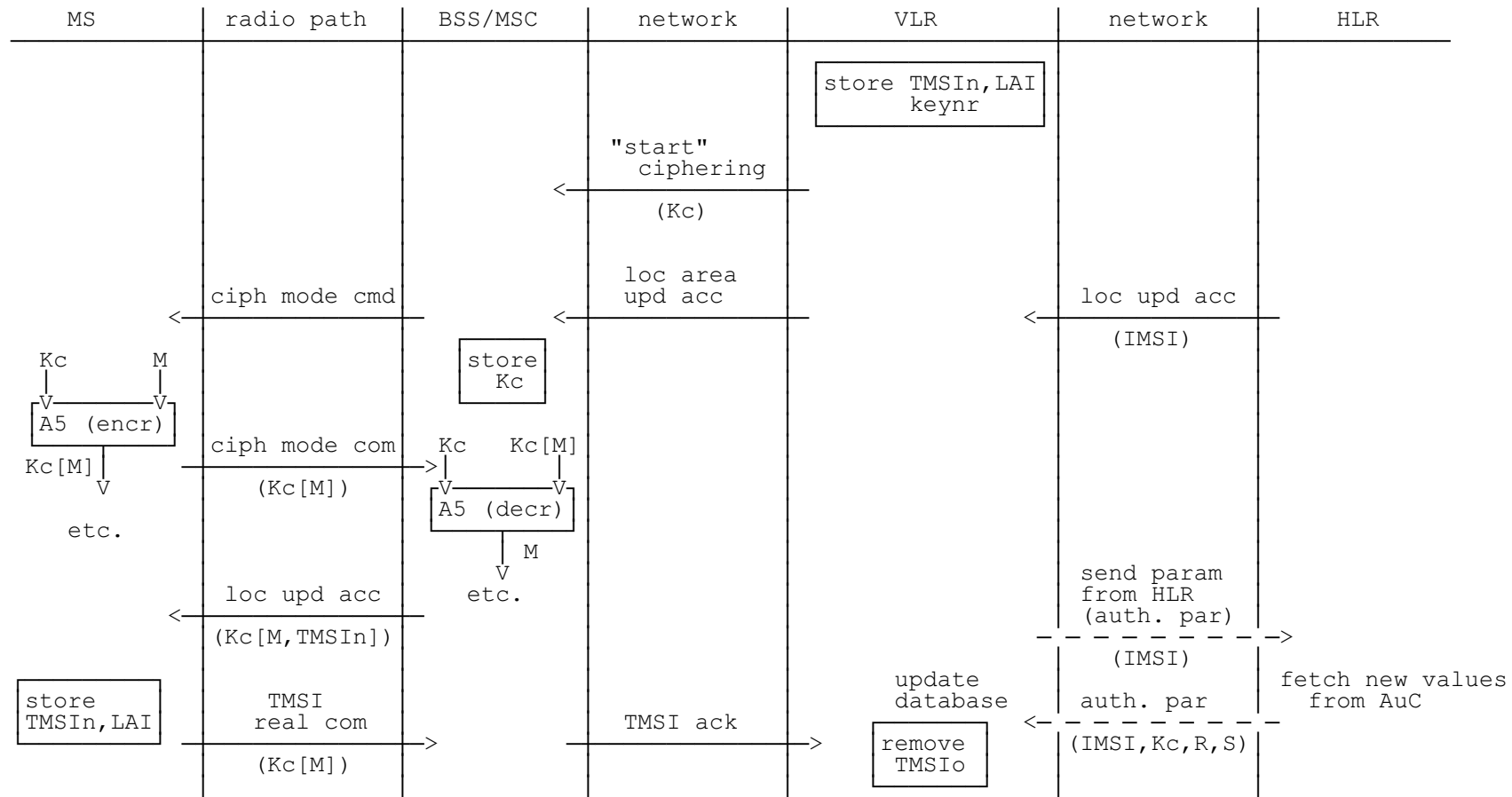

**Scheme 3:**

Location updating

- MS not yet registered in VLR
- TMSI is still available

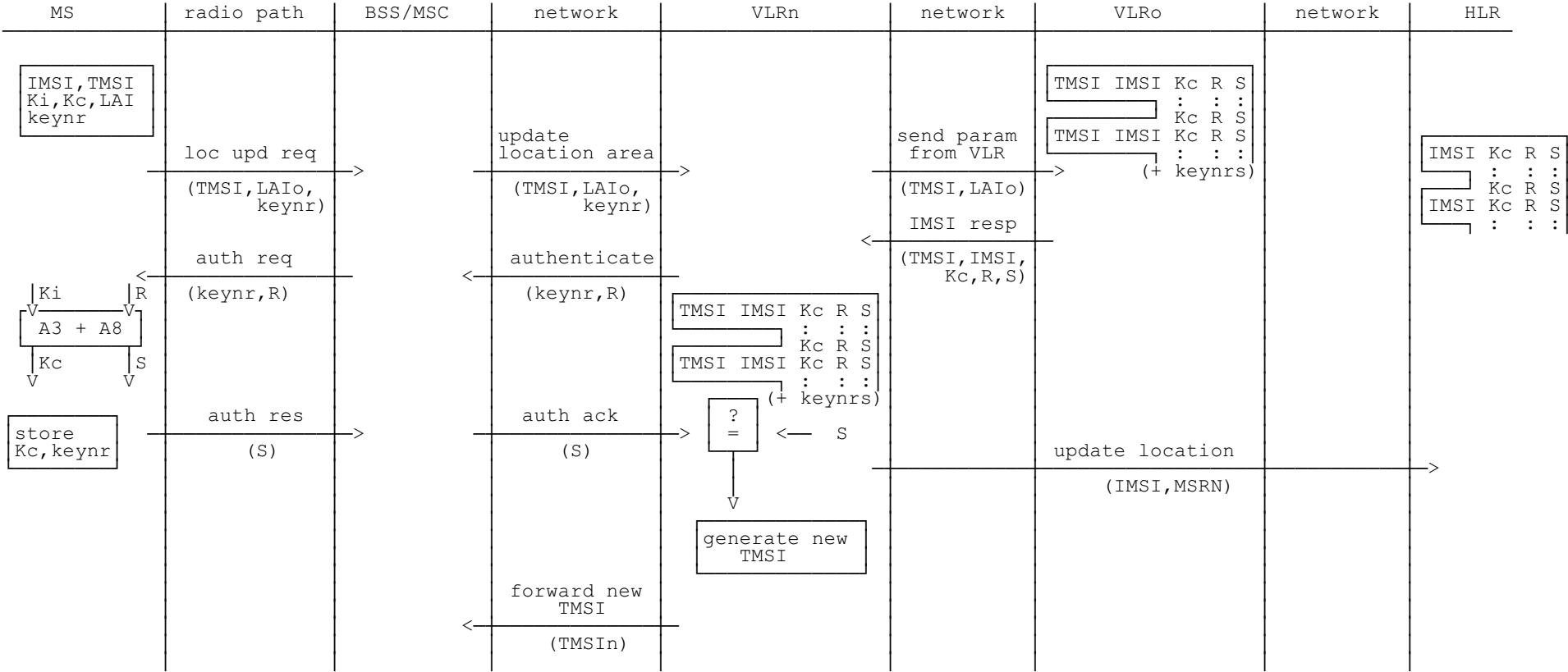

**Scheme 3 (concluded):**

Location updating

- MS not yet registered in VLR
- TMSI is still available

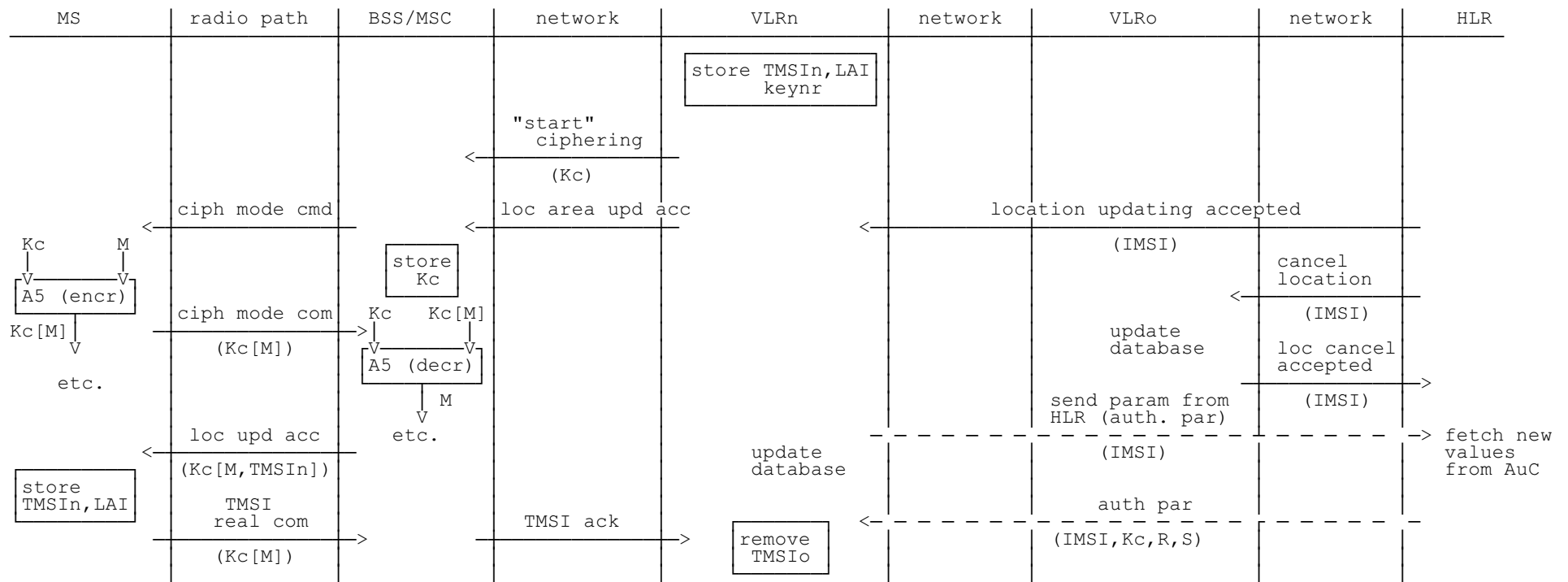

**Scheme 4:**

Location updating

- MS not yet registered in VLR; no old LAI

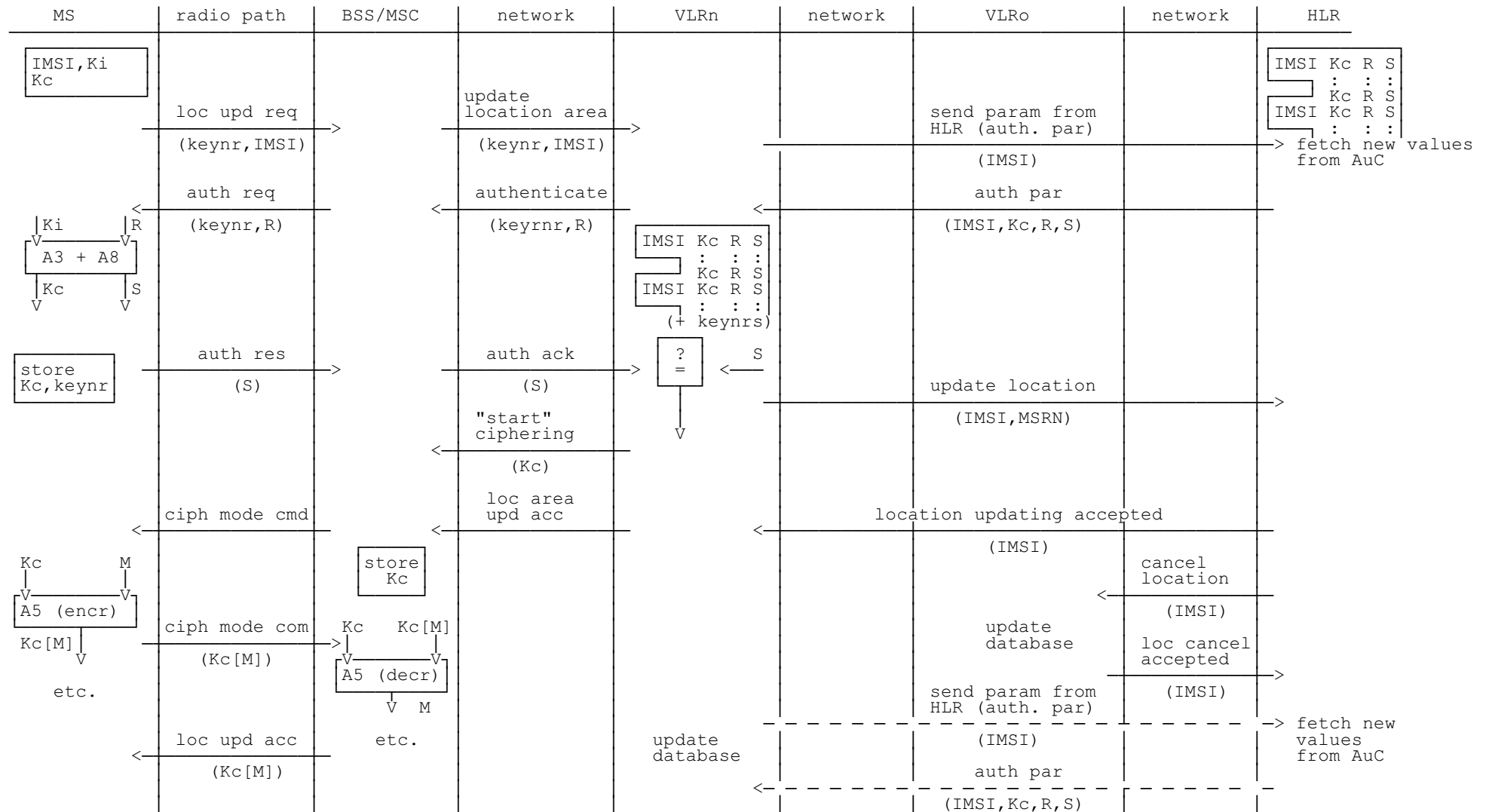

**Scheme 5:**

Call set-up

- Mobile originated
- early assignment

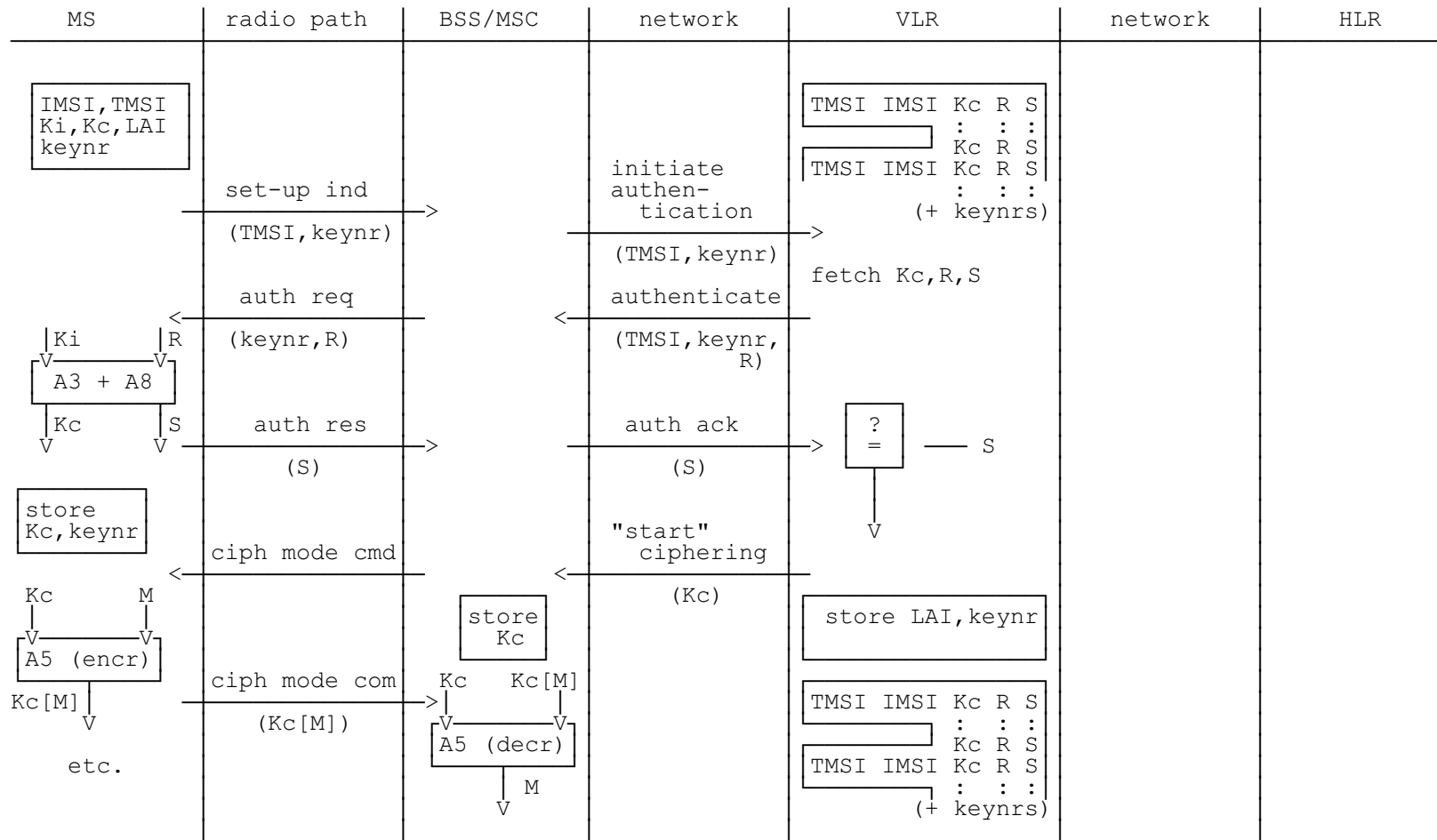



**Scheme 5 (concluded):**

Call set-up

- mobile originated
- early assignment

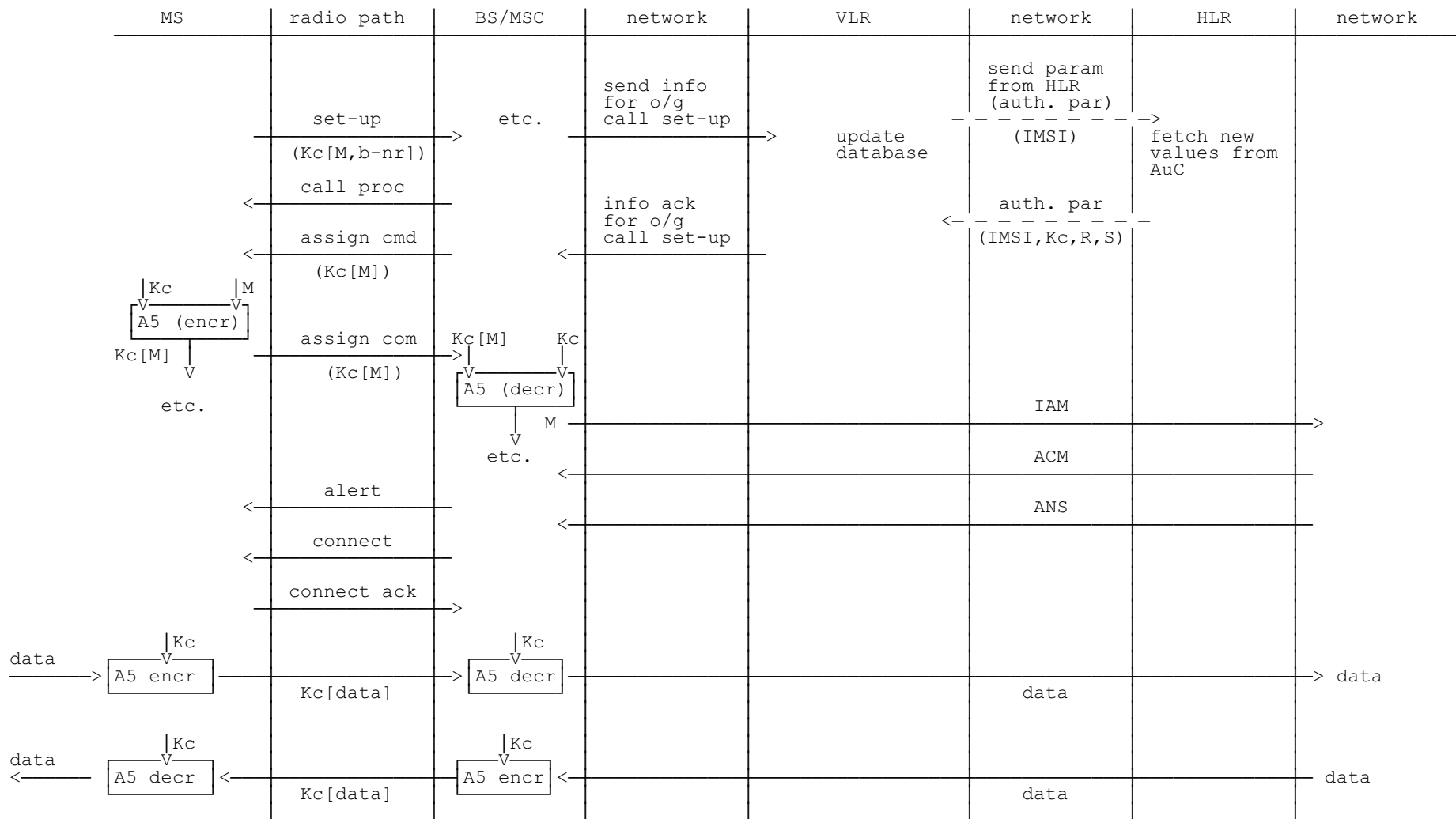

**Scheme 6:**

Call set-up

- Mobile originated
- Off air call set-up

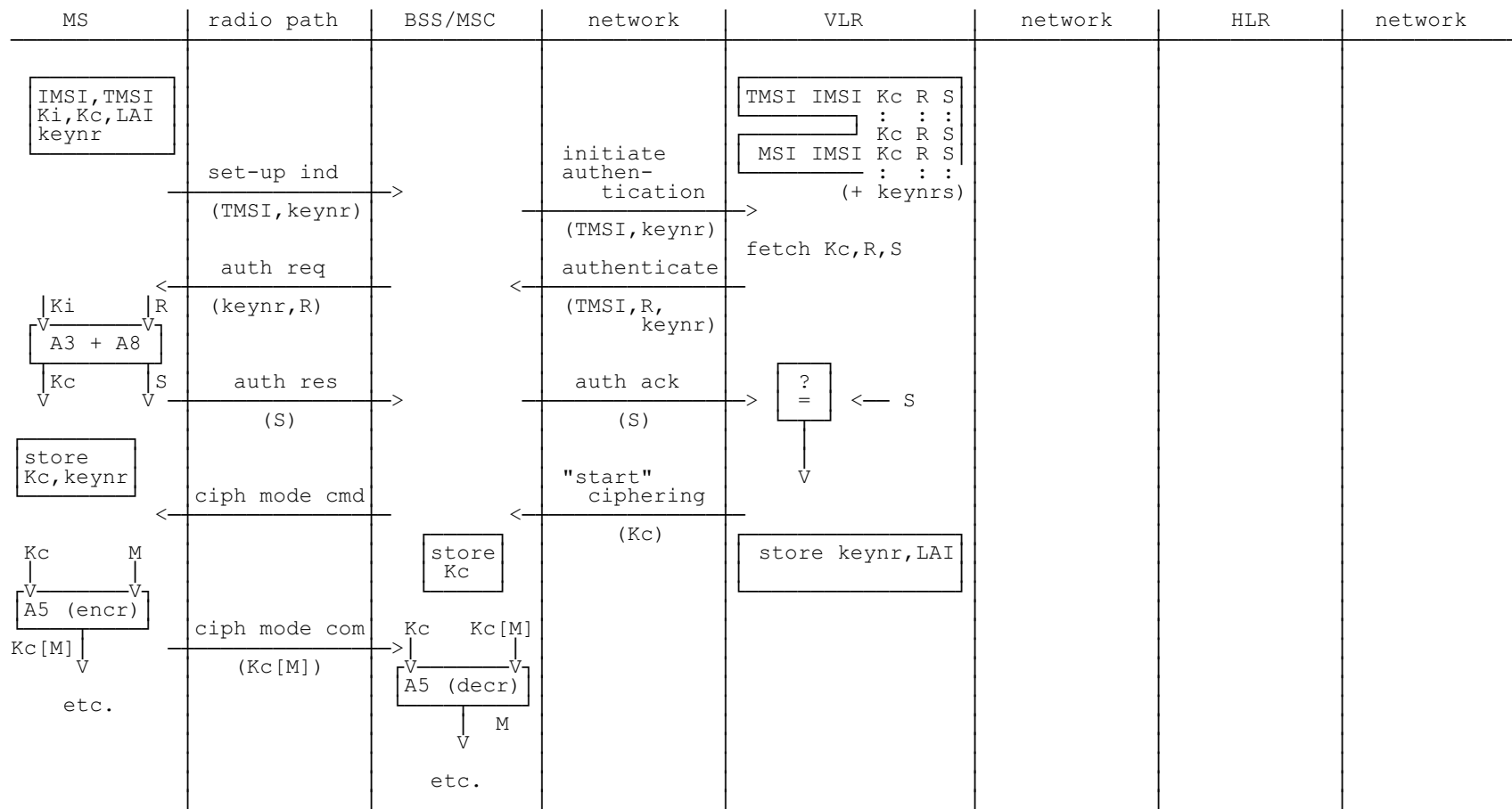

**Scheme 6 (concluded):**

Call set-up

- mobile originated
- off-air call set-up

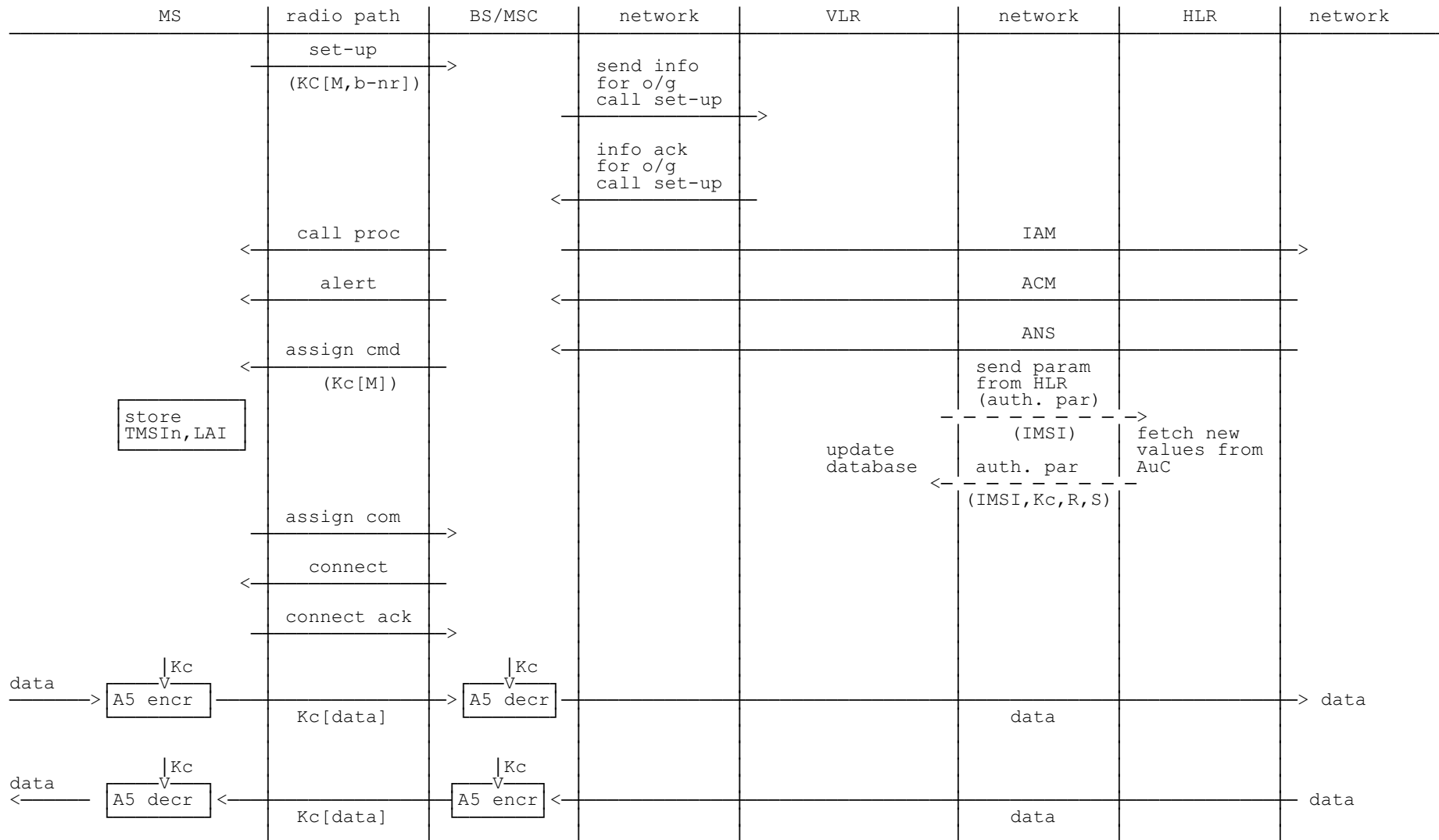

**Scheme 7:**

Call set-up

- Mobile terminated
- Early assignment

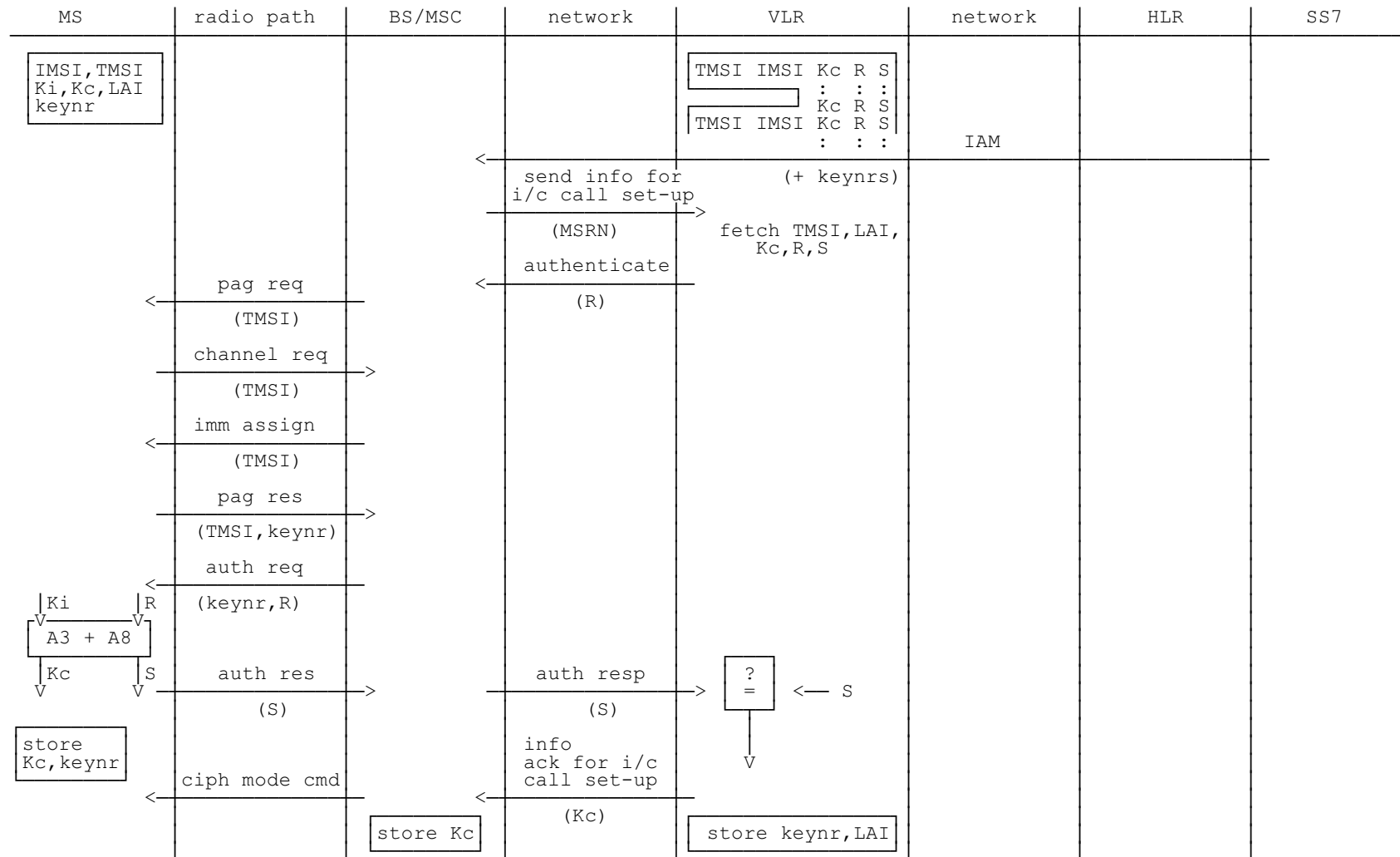

**Scheme 7 (concluded):**

Call set-up

- Mobile terminated
- Early assignment

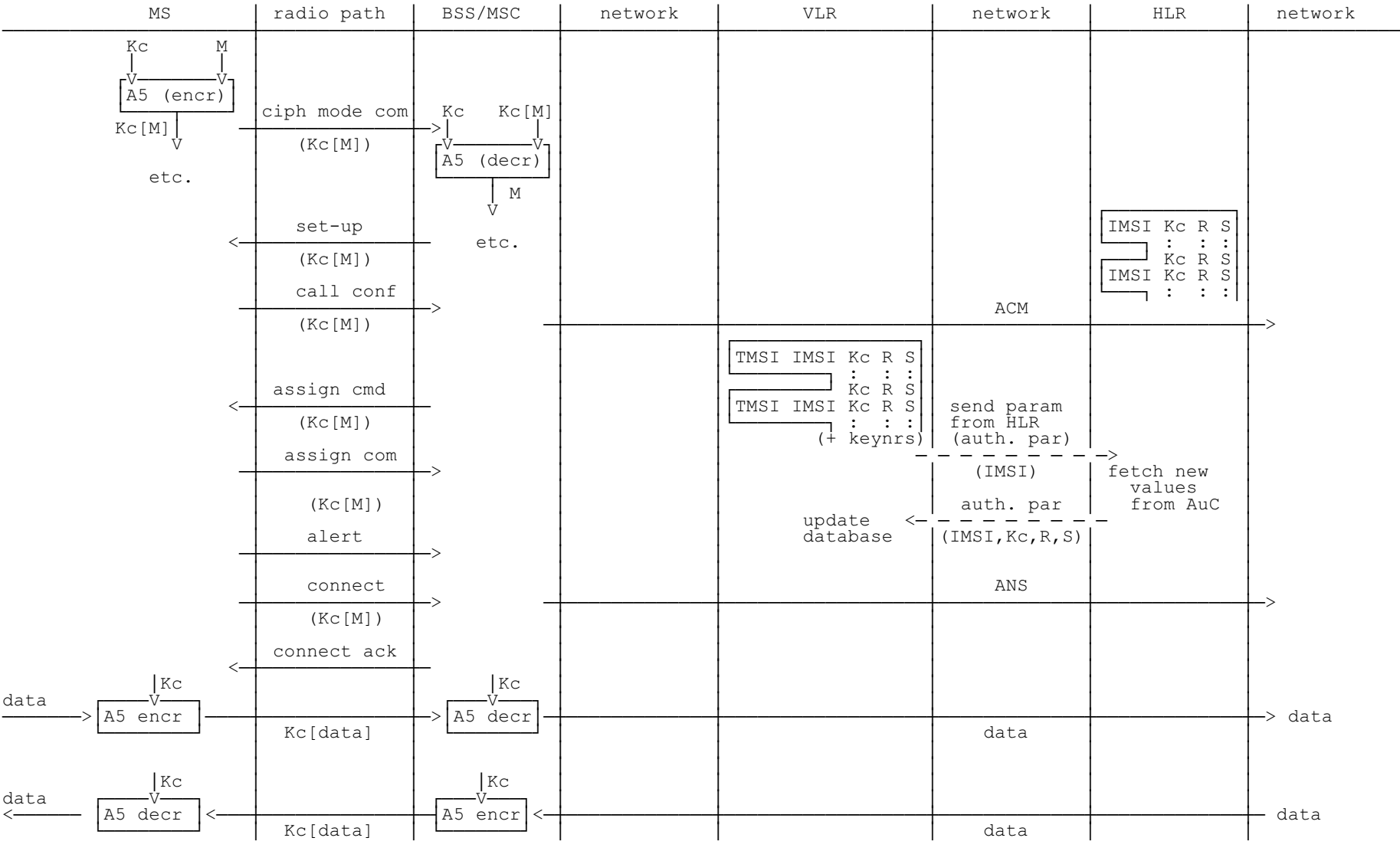

## **Annex B (informative): Security information to be stored in the entities of the GSM system**

### **B.1 Introduction**

This annex gives an overview of the security related information and the places where this information is stored in the GSM network.

The entities of the GSM network where security information is stored are:

- home location register;
- visitor location register;
- mobile services switching centre;
- base station system;
- mobile station;
- authentication centre.

### **B.2 Entities and security information**

#### **B.2.1 Home Location Register (HLR)**

If required, sets of Kc, RAND and SRES coupled to each IMSI are stored in the HLR.

#### **B.2.2 Visitor Location Register (VLR)**

Sets of Kc, RAND and SRES coupled to each IMSI are stored in the VLR. In addition the CKSN, LAI and TMSI are stored together with the presumed valid Kc.

After a new TMSI is generated, both the old and the new TMSI are stored. When the old TMSI is no longer valid, it is removed from the database.

#### **B.2.3 Mobile services Switching Centre (MSC)/Base Station System (BSS)**

Encryption algorithm A5 is stored in the MSC/BSS.

Call related information stored in the MSC includes the ciphering key Kc and CKSN associated with the identity of the mobile engaged in this call.

After a new TMSI is generated, both the old and the new TMSI are stored. When the old TMSI is no longer valid, it is removed from the database.

#### **B.2.4 Mobile Station (MS)**

The mobile station stores permanently:

- authentication algorithm A3;
- encryption algorithm A5;
- ciphering key generating algorithm A8;
- individual subscriber authentication key  $K_i$ ;
- ciphering key  $K_c$ ;
- ciphering key sequence number;
- TMSI.

The mobile station generates and stores:

- ciphering key  $K_c$ .

The mobile station receives and stores:

- ciphering key sequence number;
- TMSI;
- LAI.

#### **B.2.5 Authentication Centre (AuC)**

In the authentication centre are implemented:

- authentication algorithm(s) A3;
- ciphering key generating algorithm(s) A8.

The secret individual authentication keys  $K_i$  of each subscriber are stored in an authentication centre.

## **Annex C (normative): External specifications of security related algorithms**

### **C.0 Scope**

This annex specifies the cryptological algorithms which are needed to provide the various security features and mechanisms defined in, respectively, TS GSM 02.09 and TS GSM 03.20.

The following three algorithms are considered in TS GSM 03.20:

- Algorithm A3: Authentication algorithm;
- Algorithm A5: Ciphering/deciphering algorithm;
- Algorithm A8: Ciphering key generator.

Algorithm A5 must be common to all GSM PLMNs and all mobile stations (in particular, to allow roaming). The external specifications of Algorithm A5 are defined in section C.1.3. The internal specifications of Algorithm A5 are managed under the responsibility of GSM/MoU; they will be made available in response to an appropriate request.

Algorithms A3 and A8 are at each PLMN operator discretion. Only the formats of their inputs and outputs must be specified. It is also desirable that the processing times of these algorithms remain below a maximum value. Proposals for Algorithm A3 and A8 are managed by GSM/MoU and available, for those PLMN operators who wish to use them, in response to an appropriate request.

### **C.1 Specifications for Algorithm A5**

#### **C.1.1 Purpose**

As defined in TS GSM 03.20, Algorithm A5 realizes the protection of both user data and signalling information elements at the physical layer on the dedicated channels (TCH or DCCH).

Synchronization of both the enciphering and deciphering (especially at hand-over) must be guaranteed.

#### **C.1.2 Implementation indications**

Algorithm A5 is implemented into both the MS and the BSS. On the BSS side description below assumes that one algorithm A5 is implemented for each physical channel (TCH or DCCH).

The ciphering takes place before modulation and after interleaving (see TS GSM 05.01); the deciphering takes place after demodulation symmetrically. Both enciphering and deciphering need Algorithm A5 and start at different times (see section 4).

As an indication, recall that, due to the TDMA techniques used in the system, the useful data (also called the plain text in the sequel) are organized into blocks of 114 bits. Then, each block is incorporated into a normal burst (see TS GSM 05.02) and transmitted during a time slot. According to TS GSM 05.03, the useful information bits into a block are numbered e0 to e56 and e59 to e115 (the flag bits e57 and e58 are ignored). Successive slots for a given physical channel are separated at least by a frame duration, approximately 4.615 ms (see TS GSM 05.01).



For ciphering, Algorithm A5 produces, each 4.615 ms, a sequence of 114 encipher/decipher bits (here called BLOCK) which is combined by a bit-wise modulo 2 addition with the 114-bit plain text block. The first encipher/decipher bit produced by A5 is added to e<sub>0</sub>, the second to e<sub>1</sub> and so on. As an indication, the resulting 114-bit block is then applied to the burst builder (see TS GSM 05.01).

For each slot, deciphering is performed on the MS side with the first block (BLOCK1) of 114 bits produced by A5, and enciphering is performed with the second block (BLOCK2). As a consequence, on the network side BLOCK1 is used for enciphering and BLOCK2 for deciphering. Therefore Algorithm A5 must produce two blocks of 114 bits (i.e. BLOCK1 and BLOCK2) each 4.615 ms.

Synchronization is guaranteed by driving Algorithm A5 by an explicit time variable, COUNT, derived from the TDMA frame number. Therefore each 114-bit block produced by A5 depends only on the TDMA frame numbering and the ciphering key K<sub>c</sub>.

COUNT is expressed in 22 bits as the concatenation of the binary representation of T1, T3 and T2. It is an input parameter of Algorithm A5. The coding of COUNT is shown in figure C.1.

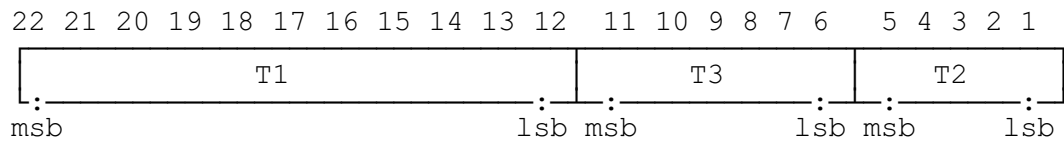

Figure C.1: The coding of COUNT

Binary representation of COUNT. Bit 22 is the most significant bit (msb) and bit 1 the least significant bit (lsb) of COUNT. T1, T3 and T2 are represented in binary. (For definition of T1, T3 and T2, see TS GSM 05.02).

Figure C.2 summarizes the implementation indications listed above, with only one enciphering/deciphering procedure represented (the second one for deciphering/enciphering is symmetrical).

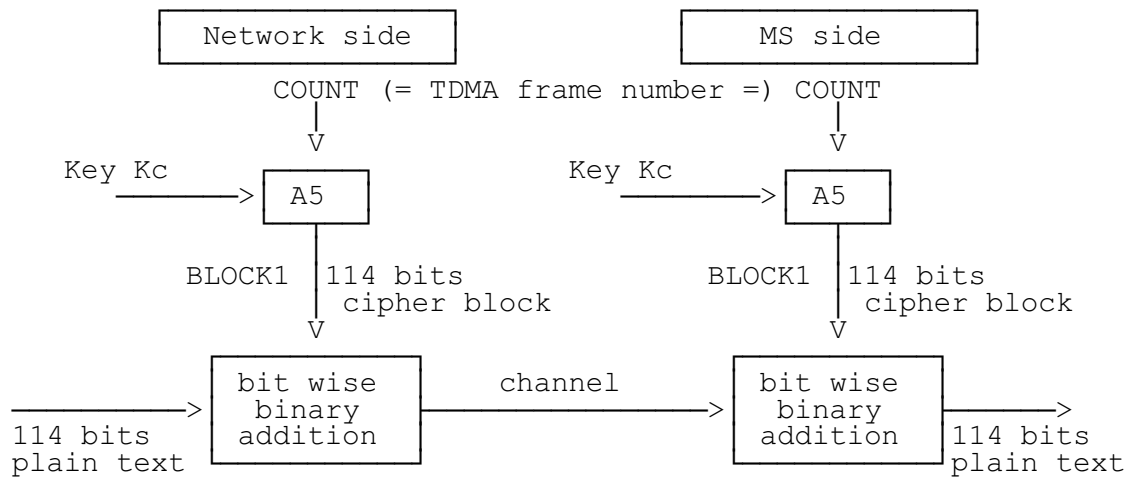

Figure C.2: Deciphering on the MS side

### C.1.3 External specifications of Algorithm A5

The two input parameters (COUNT and Kc) and the output parameters (BLOCK1 and BLOCK2) of Algorithm A5 shall use the following formats:

- length of Kc: 64 bits;
- length of COUNT: 22 bits;
- length of BLOCK1: 114 bits;
- length of BLOCK2: 114 bits.

Algorithm A5 shall produce BLOCK1 and BLOCK2 in less than a TDMA frame duration, i.e. 4.615 ms.

NOTE: If the actual length of the ciphering key is less than 64 bits, then it is assumed that the actual ciphering key corresponds to the most significant bits of Kc, and that the remaining and less significant bits are set to zero.

### C.1.4 Internal specification of Algorithm A5

The internal specification of Algorithm A5 is managed under the responsibility of GSM/MoU; it will be made available to in response to an appropriate request.

## C.2 Algorithm A3

Algorithm A3 is considered as a matter for GSM PLMN operators. Therefore, only external specifications are given. However a proposal for a possible Algorithm A3 is managed by GSM/MoU and available upon appropriate request.

### C.2.1 Purpose

As defined in TS GSM 03.20, the purpose of Algorithm A3 is to allow authentication of a mobile subscriber's identity.

To this end, Algorithm A3 must compute an expected response SRES from a random challenge RAND sent by the network. For this computation, Algorithm A3 makes use of the secret authentication key Ki.

### C.2.2 Implementation and operational requirements

On the MS side, Algorithm A3 is contained in a Subscriber Identity Module, as specified in TS GSM 02.17.

On the network side, it is implemented in the HLR or the AuC. The two input parameters (RAND and Ki) and the output parameter (SRES) of Algorithm A3 shall use the following formats:

- length of Ki: 128 bits;
- length of RAND: 128 bits;
- length of SRES: 32 bits.

The run-time of Algorithm A3 shall be less than 500 ms.

### **C.3 Algorithm A8**

Algorithm A8 is considered as a matter for GSM PLMN operators as is Algorithm A3.

A proposal for a possible Algorithm A8 is managed by GSM/MoU and available upon appropriate request.

#### **C.3.1 Purpose**

As defined in TS GSM 03.20, Algorithm A8 must compute the ciphering key  $K_c$  from the random challenge RAND sent during the authentication procedure, using the authentication key  $K_i$ .

#### **C.3.2 Implementation and operational requirements**

On the MS side, Algorithm A8 is contained in the SIM, as specified in TS GSM 02.17.

On the network side, Algorithm A8 is co-located with Algorithm A3.

The two input parameters (RAND and  $K_i$ ) and the output parameter ( $K_c$ ) of Algorithm A8 shall follow the following formats:

- length of  $K_i$ : 128 bits;
- length of RAND: 128 bits;
- length of  $K_c$ : 64 bits.

Since the maximum length of the actual ciphering key is fixed by GSM/MoU, Algorithm A8 shall produce this actual ciphering key and extend it (if necessary) into a 64 bit word where the non-significant bits are forced to zero. It is assumed that any non-significant bits are the least significant bits and that, the actual ciphering key is contained in the most significant bits.

## History

<b>Document history</b>	
September 1994	First Edition
November 1995	Converted into Adobe Acrobat Portable Document Format (PDF)