



EUROPEAN
TELECOMMUNICATION
STANDARD

FINAL DRAFT
pr **ETS 300 497-9**

November 1997

Second Edition

Source: DECT

Reference: RE/DECT-040094-9

ICS: 33.020

Key words: ATS, DECT, radio, testing

**Digital Enhanced Cordless Telecommunications (DECT);
Common Interface (CI) Test Case Library (TCL);
Part 9: Abstract Test Suite (ATS) for Network (NWK) layer -
Fixed radio Termination (FT)**

ETSI

European Telecommunications Standards Institute

ETSI Secretariat

Postal address: F-06921 Sophia Antipolis CEDEX - FRANCE

Office address: 650 Route des Lucioles - Sophia Antipolis - Valbonne - FRANCE

X.400: c=fr, a=atlas, p=etsi, s=secretariat - **Internet:** secretariat@etsi.fr

Tel.: +33 4 92 94 42 00 - Fax: +33 4 93 65 47 16

Copyright Notification: No part may be reproduced except as authorized by written permission. The copyright and the foregoing restriction extend to reproduction in all media.

© European Telecommunications Standards Institute 1997. All rights reserved.

Contents

Foreword	5
1 Scope	7
2 Normative references	7
3 Definitions abbreviations	9
3.1 Definitions	9
3.2 Abbreviations	9
4 Abstract Test Method (ATM)	10
4.1 ATM	10
4.2 DLC primitives.....	11
4.2.1 S-SAP primitives	11
4.2.2 B-SAP primitives	14
4.3 TC execution sequence	14
5 Untestable Test Purposes (TP).....	15
5.1 Control protocol.....	15
6 ATS Conventions	15
6.1 Naming conventions	15
6.1.1 Declarations part	15
6.1.1.1 Test suite type, ASP and PDU type definitions.....	16
6.1.1.2 Test Suite Operations (TSO) definitions.....	16
6.1.1.3 Test Suite Parameter (TSP) declarations.....	16
6.1.1.4 Test Case Selection (TCS) expression definitions	16
6.1.1.5 Test Suite Constant (TSC) declarations	16
6.1.1.6 Test Suite Variable (TSV) declarations	16
6.1.1.7 Test Case Variable (TCV) declarations	17
6.1.1.8 Point of Control and Observation (PCO) declarations.....	17
6.1.1.9 Timer declarations	17
6.1.1.10 ASP type definitions.....	17
6.1.1.11 PDU type definitions	17
6.1.1.12 Alias definitions.....	18
6.1.2 Constraints part.....	18
6.1.3 Dynamic part	19
6.1.3.1 Test Case (TC) identifier	19
6.1.3.2 Test Step (TS) identifier.....	20
6.1.3.3 Default identifier.....	20
6.1.3.4 General aspects	20
6.1.3.5 ATS abbreviations	20
6.2 Implementation conventions	21
6.2.1 Declaration part	21
6.2.2 Constraint part.....	21
6.2.3 Dynamic part	21
6.2.4 Documentation	22
6.2.5 Coding of some information elements.....	22
Annex A (normative): Abstract test suite for NWK testing	23
A.1 The machine processable ATS (TTCN.MP)	23
A.2 The graphical ATS (TTCN.GR).....	23
Annex B (normative): Partial PIXIT proforma.....	24

B.1	Identification summary.....	24
B.2	ATS summary.....	24
B.3	Test laboratory.....	24
B.4	Client identification.....	24
B.5	SUT.....	24
B.6	Protocol layer information.....	25
B.6.1	Protocol identification.....	25
B.6.2	IUT information.....	26
Annex C (normative):	Protocol Conformance Test Report (PCTR) Proforma for DECT NWK.....	32
C.1	Identification summary.....	32
C.1.1	Protocol conformance test report.....	32
C.1.2	IUT identification.....	32
C.1.3	Testing environment.....	32
C.1.4	Limits and reservation.....	32
C.1.5	Comments.....	33
C.2	IUT Conformance status.....	33
C.3	Static conformance summary.....	33
C.4	Dynamic conformance summary.....	33
C.5	Static conformance review report.....	33
C.6	Test campaign report.....	34
C.7	Observations.....	36
Annex D (informative):	Bibliography.....	37
History	38

Foreword

This final draft second edition European Telecommunication Standard (ETS) has been produced by the Digital Enhanced Cordless Telecommunications (DECT) Project of the European Telecommunications Standards Institute (ETSI), and is now submitted for the Voting phase of the ETSI standards approval procedure.

This ETS comprises nine parts, as follows:

- Part 1: "Test Suite Structure (TSS) and Test Purposes (TP) for Medium Access Control (MAC) layer";
- Part 2: "Abstract Test Suite (ATS) for Medium Access Control (MAC) layer - Portable radio Termination (PT)";
- Part 3: "Abstract Test Suite (ATS) for Medium Access Control (MAC) layer - Fixed radio Termination (FT)";
- Part 4: "Test Suite Structure (TSS) and Test Purposes (TP) - Data Link Control (DLC) layer";
- Part 5: "Abstract Test Suite (ATS) - Data Link Control (DLC) layer";
- Part 6: "Test Suite Structure (TSS) and Test Purposes (TP) - Network (NWK) layer - Portable radio Termination (PT)";
- Part 7: "Abstract Test Suite (ATS) for Network (NWK) layer - Portable radio Termination (PT)";
- Part 8: "Test Suite Structure (TSS) and Test Purposes (TP) - Network (NWK) layer - Fixed radio Termination (FT)";
- Part 9: "Abstract Test Suite (ATS) for Network (NWK) layer - Fixed radio Termination (FT)".**

Proposed transposition dates	
Date of latest announcement of this ETS (doa):	3 months after ETSI publication
Date of latest publication of new National Standard or endorsement of this ETS (dop/e):	6 months after doa
Date of withdrawal of any conflicting National Standard (dow):	6 months after doa

Blank page

1 Scope

This European Telecommunication Standard (ETS) contains the Abstract Test Suite (ATS) to test the Network (NWK) layer, Fixed radio Termination (FT).

The objective of this test specification is to provide a basis for approval tests for DECT equipment giving a high probability of air interface inter-operability between different manufacturer's DECT equipment. Part 9 of this test specification contains the Abstract Test Suite for testing of the NWK layer at the FT.

The ISO standard for the methodology of conformance testing (ISO/IEC 9646) as well as the ETSI rules for conformance testing (protocol and profile conformance testing specifications, standardization methodology ETS 300 406 [10]) are used as basis for the test methodology.

Annex B provides the partial Protocol Implementation Extra Information for Testing (PIXIT) proforma.

2 Normative references

This ETS incorporates, by dated or undated reference, provisions from other publications. These normative references are cited at the appropriate places in the text and the publications are listed hereafter. For dated references, subsequent amendments to or revisions of any of these publications apply to this ETS only when incorporated in it by amendment or revision. For undated references the latest edition of the publication referred to applies.

- [1] ETS 300 175-1: "Digital Enhanced Cordless Telecommunications (DECT); Common Interface (CI); Part 1: Overview".
- [2] ETS 300 175-2: "Digital Enhanced Cordless Telecommunications (DECT); Common Interface (CI); Part 2: Physical layer (PHL)".
- [3] ETS 300 175-3: "Digital Enhanced Cordless Telecommunications (DECT); Common Interface (CI); Part 3: Medium Access Control (MAC) layer".
- [4] ETS 300 175-4: "Digital Enhanced Cordless Telecommunications (DECT); Common Interface (CI); Part 4: Data Link Control (DLC) layer".
- [5] ETS 300 175-5: "Digital Enhanced Cordless Telecommunications (DECT); Common Interface (CI); Part 5: Network (NWK) layer".
- [6] ETS 300 175-6: "Digital Enhanced Cordless Telecommunications (DECT); Common Interface (CI); Part 6: Identities and addressing".
- [7] ETS 300 175-7: "Digital Enhanced Cordless Telecommunications (DECT); Common Interface (CI); Part 7: Security features".
- [8] ETS 300 175-8: "Digital Enhanced Cordless Telecommunications (DECT); Common Interface (CI); Part 8: Speech coding and transmission".
- [9] ETS 300 324-3: "Signalling Protocols and Switching (SPS); V interfaces at the digital Local Exchange (LE); V5.1 interface for the support of Access Network (AN); Part 3: Test Suite Structure and Test Purposes (TSS&TP) specification for the network layer (AN side)".
- [10] ETS 300 406: "Methods for Testing and Specification (MTS); Protocol and profile conformance testing specifications; Standardization methodology".
- [11] ETS 300 444: "Digital European Cordless Telecommunications (DECT); Generic Access Profile (GAP)".
- [12] ISO/IEC 9646-1 (1991): "Information technology - Open Systems Interconnection - Conformance testing methodology and framework - Part 1: General concepts". (See also CCITT Recommendation X.290 (1991)).

- [13] ISO/IEC 9646-2 (1991): "Information technology - Open Systems Interconnection - Conformance testing methodology and framework - Part 2: Abstract test suite specification". (See also CCITT Recommendation X.291 (1991)).
- [14] ISO/IEC 9646-3 (1991): "Information technology - Open Systems Interconnection - Conformance testing methodology and framework - Part 3: The tree and tabular combined notation". (See also CCITT Recommendation X.292 (1992)).
- [15] ISO/IEC 9646-4 (1991): "Information technology - Open Systems Interconnection - Conformance testing methodology and framework - Part 4: Test realisation". (See also CCITT Recommendation X.292 (1992)).
- [16] ISO/IEC 9646-5 (1991): "Information technology - Open Systems Interconnection - Conformance testing methodology and framework - Part 5: Requirements on test laboratories and clients for the conformance assessment process". (See also CCITT Recommendation X.292 (1992)).
- [17] ISO/IEC 9646-6 (1991): "Information technology - Open Systems Interconnection - Conformance testing methodology and framework - Part 6: Protocol profile test specification".
- [18] ISO/IEC 9646-7 (1991): "Information technology - Open Systems Interconnection - Conformance testing methodology and framework - Part 7: Implementation conformance statement".
- [19] 91/263/EEC: "Council Directive of 29 April 1991 on the approximation of the laws of the Member States concerning telecommunications terminal equipment, including the mutual recognition of their conformity" (Terminal Directive).
- [20] TBR 6: "Digital Enhanced Cordless Telecommunications (DECT); General terminal attachment requirements".
- [21] TBR 10: "Digital Enhanced Cordless Telecommunications (DECT); General terminal attachment requirements; Telephony applications".
- [22] TBR 11: "Attachment requirements for terminal equipment for Digital Enhanced Cordless Telecommunications (DECT) Public Access Profile (PAP) applications".
- [23] TBR 22: "Attachment requirements for terminal equipment for Digital Enhanced Cordless Telecommunications (DECT) Generic Access Profile (GAP) applications".

3 Definitions abbreviations

3.1 Definitions

For the purposes of this ETS, the definitions given in ISO/IEC 9646-1 [12], ISO/IEC 9646-2 [13], ETS 300 175-1 [1], ETS 300 175-5 [5], ETS 300 175-6 [6] and ETS 300 175-7 [7] apply.

3.2 Abbreviations

For the purposes of this ETS, the following abbreviations apply:

AC	Authentication Code
ASP	Abstract Service Primitive
ATS	Abstract Test Suite
AU	Authentication
BI	Invalid Behaviour
BO	Inopportune Behaviour
BV	Valid Behaviour
CC	Call Control
CH	Ciphering
CI	Call Information
CR	Call Release
DECT	Digital Enhanced Cordless Telecommunication
DLC	Data Link Control
FT	Fixed radio termination
IC	Incoming Call
ID	Identification
IPEI	International Portable Equipment Identity
IPUI	International Portable User Identity
IUT	Implementation Under Test
IWU	Interworking Unit
KA	Key Allocation
LC	Link Control
LE	Connection oriented Link Establishment
LO	Location
LR	Connection oriented Link Release
LS	Connection oriented Link Suspend and resume
LT	Lower Tester
MAC	Medium Access Control
ME	Management Entity
MM	Mobility Management
MO	Connection Oriented Message Services
NWK	Network layer
OC	Outgoing Call
PARK	Portable Access Rights Key
PCO	Point of Control and Observation
PDU	Protocol Data Unit
PICS	Protocol Implementation Conformance Statement
PIXIT	Protocol Implementation Extra Information for Testing
PR	Parameter Retrieval
PT	Portable radio Termination
RPN	Radio fixed Part Number
RS	Call Related Supplementary Services
SUT	System Under Test
TCS	Test Case Selection
TCV	Test Case Variable
TP	Test Purposes
TSO	Test Suite Operations
TSP	Test Suite Parameter
TSV	Test Suite Variable
TTCN	Tree and Tabular Combined Notation
UAK	User Authentication Key
UT	Upper Tester

4 Abstract Test Method (ATM)

This clause describes the ATM, the Point of Control and Observation (PCO) used to test the NWK layer of the FT.

4.1 ATM

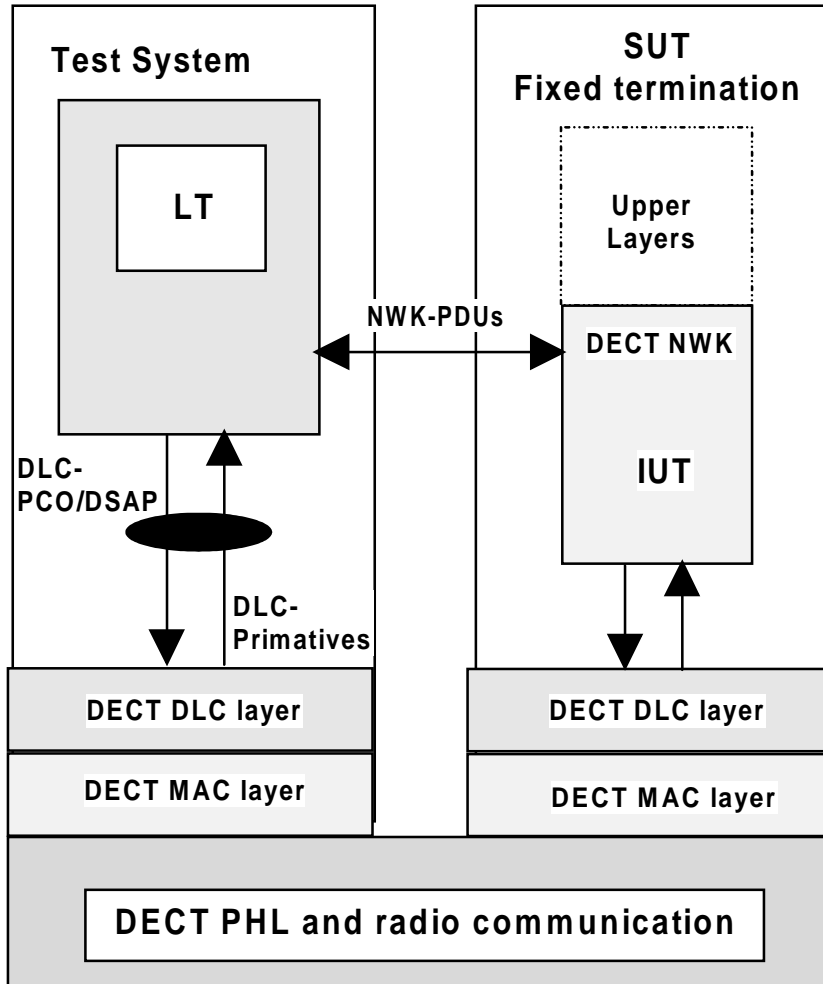

Figure 1: Remote single layer test method embedded variant

- LT:** a Lower Tester (LT) is located in a remote DECT test system. It controls and observes the behaviour of the Implementation Under Test (IUT).
- DSAP:** a unique Data Link Control (DLC) SAP is defined at the DECT interface and used to exchange service data of the NWK protocol.
- PCO:** the PCO for Network Layer testing is located on the DSAP. All test events at the PCO are specified in terms of DLC Abstract Service Primitives (ASPs) and NWK Protocol Data Units (PDUs).
- Upper layers/tester:** no explicit Upper Tester (UT) exists in the test system. However, the System Under Test (SUT) needs to carry out some UT functions to achieve some effects of test co-ordination procedures. Designing ATS, the capability of the Interworking Unit (IWU), such as PSTN, ISDN or GSM IWUs might be taken into account. An example of such controls could be to provoke restarting of the IUT through the Q interface.

4.2 DLC primitives

In this subclause the DSAP primitives are defined according to ETS 300 175-4 [4], subclause 8.3.2 (S-SAP primitives) and ETS 300 175-4 [4], subclause 8.3.3 (B-SAP primitives).

4.2.1 S-SAP primitives

Table 1: DL_DATA_IND primitive

ASP Declaration		
ASP NAME DL_DATA_IND	PCO TYPE S-SAP	COMMENTS ETS 300 175-4 [4], subclause 8.3.2.3
Service control information		
Parameter name	Type	Comments
data_link_endpoint_identifier	DATA_LINK_ENDPOINT_IDENTIFIER (INTEGER)	ETS 300 175-4 [4], subclause 7.3.6
message_unit	PDU	ETS 300 175-4 [4], subclause 8.3.1

Table 2: DL_DATA_REQ primitive

ASP Declaration		
ASP NAME DL_DATA_REQ	PCO TYPE S-SAP	COMMENTS ETS 300 175-4 [4], subclause 8.3.2.3
Service control information		
Parameter name	Type	Comments
data_link_endpoint_identifier	DATA_LINK_ENDPOINT_IDENTIFIER (INTEGER)	ETS 300 175-4 [4], subclause 7.3.6
message_unit	PDU	ETS 300 175-4 [4], subclause 8.3.1

Table 3: DL_ENCRYPT_CNF primitive

ASP Declaration		
ASP NAME DL_ENCRYPT_CNF	PCO TYPE S-SAP	COMMENTS ETS 300 175-4 [4], subclause 8.3.2.8
Service control information		
Parameter name	Type	Comments
data_link_endpoint_identifier	DATA_LINK_ENDPOINT_IDENTIFIER (INTEGER)	ETS 300 175-4 [4], subclause 7.3.6
encryption_status	CIPHER_STATUS (INTEGER(0,1))	ETS 300 175-4 [4], subclause 8.3.1

Table 4: DL_ENCRYPT_IND primitive

ASP Declaration		
ASP NAME DL_ENCRYPT_IND	PCO TYPE S-SAP	COMMENTS ETS 300 175-4 [4], subclause 8.3.2.8
Service control information		
Parameter name	Type	Comments
data_link_endpoint_identifier	DATA_LINK_ENDPOINT_IDENTIFIER (INTEGER)	ETS 300 175-4 [4], subclause 7.3.6
connection_identities	CONNECTION_IDENTITIES (OCTETSTRING)	ETS 300 175-4 [4], subclause 8.3.1
encryption_status	CIPHER_STATUS (INTEGER(0,1))	ETS 300 175-4 [4], subclause 8.3.1

Table 5: DL_ENCRYPT_REQ primitive

ASP Declaration		
ASP NAME DL_ENCRYPT_REQ	PCO TYPE S-SAP	COMMENTS ETS 300 175-4 [4], subclause 8.3.2.8
Service control information		
Parameter name	Type	Comments
data_link_endpoint_identifier	DATA_LINK_ENDPOINT_IDENTIFIER (INTEGER)	ETS 300 175-4 [4], subclause 7.3.6
connection_identities	CONNECTION_IDENTITIES (OCTETSTRING)	ETS 300 175-4 [4], subclause 8.3.1
encryption_status	CIPHER_STATUS (INTEGER(0,1))	ETS 300 175-4 [4], subclause 8.3.1

Table 6: DL_ENC_KEY_REQ primitive

ASP Declaration		
ASP NAME DL_ENC_KEY_REQ	PCO TYPE S-SAP	COMMENTS ETS 300 175-4 [4], subclause 8.3.2.7
Service control information		
Parameter name	Type	Comments
data_link_endpoint_identifier	DATA_LINK_ENDPOINT_IDENTIFIER (INTEGER)	ETS 300 175-4 [4], 7.3.6
connection_identities	CONNECTION_IDENTITIES (OCTETSTRING)	ETS 300 175-4 [4], 8.3.1
encryption_key	ENCRYPTION_KEY (BITSTRING[64])	ETS 300 175-4 [4], 8.3.1

Table 7: DL_ESTABLISH_CNF primitive

ASP Declaration		
ASP NAME DL_ESTABLISH_CNF	PCO TYPE S-SAP	COMMENTS ETS 300 175-4 [4], subclause 8.3.2.1
Service control information		
Parameter name	Type	Comments
data_link_endpoint_identifier	DATA_LINK_ENDPOINT_IDENTIFIER (INTEGER)	ETS 300 175-4 [4], subclause 7.3.6

Table 8: DL_ESTABLISH_IND primitive

Table 8 is deleted.

Table 9: DL_ESTABLISH_REQ primitive

ASP Declaration		
ASP NAME DL_ESTABLISH_REQ	PCO TYPE S-SAP	COMMENTS ETS 300 175-4 [4], subclause 8.3.2.1
Service control information		
Parameter name	Type	Comments
data_link_endpoint_identifier	DATA_LINK_ENDPOINT_IDENTIFIER (INTEGER)	ETS 300 175-4 [4], subclause 7.3.6
establish_mode	ESTABLISH_MODE (INTEGER(0,1,2))	ETS 300 175-4 [4], subclause 8.3.1
radio_fixed_part_number	RADIO_FIXED_PART_NUMBER (INTEGER)	ETS 300 175-4 [4], subclause 8.3.1
message_unit	PDU	ETS 300 175-4 [4], subclause 8.3.1

Table 10: DL_ESTABLISH_RES primitive

ASP Declaration		
ASP NAME DL_ESTABLISH_RES	PCO TYPE S-SAP	COMMENTS ETS 300 175-4 [4], subclause 8.3.2.1
Service control information		
Parameter name	Type	Comments
data_link_endpoint_identifier	DATA_LINK_ENDPOINT_IDENTIFIER (INTEGER)	ETS 300 175-4 [4], subclause 7.3.6

Table 11: DL_RELEASE_CNF primitive

ASP Declaration		
ASP NAME DL_RELEASE_CNF	PCO TYPE S-SAP	COMMENTS ETS 300 175-4 [4], subclause 8.3.2.2
Service control information		
Parameter name	Type	Comments
data_link_endpoint_identifier	DATA_LINK_ENDPOINT_IDENTIFIER (INTEGER)	ETS 300 175-4 [4], subclause 7.3.6
release_mode	RELEASE_MODE (INTEGER(0,1))	ETS 300 175-4 [4], subclause 8.3.1

Table 12: DL_RELEASE_IND primitive

ASP Declaration		
ASP NAME DL_RELEASE_IND	PCO TYPE S-SAP	COMMENTS ETS 300 175-4 [4], subclause 8.3.2.2
Service control information		
Parameter name	Type	Comments
data_link_endpoint_identifier	DATA_LINK_ENDPOINT_IDENTIFIER (INTEGER)	ETS 300 175-4 [4], subclause 7.3.6
release_mode	RELEASE_MODE (INTEGER(0,1))	ETS 300 175-4 [4], subclause 8.3.1

Table 13: DL_RELEASE_REQ primitive

ASP Declaration		
ASP NAME DL_RELEASE_REQ	PCO TYPE S-SAP	COMMENTS ETS 300 175-4 [4], subclause 8.3.2.2
Service control information		
Parameter name	Type	Comments
data_link_endpoint_identifier	DATA_LINK_ENDPOINT_IDENTIFIER (INTEGER)	ETS 300 175-4 [4], subclause 7.3.6
release_mode	RELEASE_MODE (INTEGER(0,1))	ETS 300 175-4 [4], subclause 8.3.1

4.2.2 B-SAP primitives

Table 14: DL_BROADCAST_IND primitive

ASP Declaration		
ASP NAME DL_BROADCAST_IND	PCO TYPE B-SAP	COMMENTS ETS 300 175-4 [4], subclause 8.3.3.1
Service control information		
Parameter name	Type	Comments
cluster_address_list	CLUSTER_ADDRESS_LIST (OCTETSTRING)	ETS 300 175-4 [4], subclause 8.3.1
message_unit	PDU	ETS 300 175-4 [4], subclause 8.3.1
extended_message_flag	BIT_1 (BITSTRING[1])	ETS 300 175-4 [4], subclause 8.3.1
error_flag	BIT_1 (BITSTRING[1])	ETS 300 175-4 [4], subclause 8.3.1

Table 15: DL_BROADCAST_REQ primitive

Table 15 is deleted.

4.3 TC execution sequence

The test cases can be executed in any order, there are no restrictions on this matter.

5 Untestable Test Purposes (TP)

This clause gives a list of TP which are not implemented in the ATS (annex A) due to the chosen ATM or other restrictions.

5.1 Control protocol

The following test purposes are not implemented in the ATS due to unknown reaction of the IUT after testing the TP:

Table 16: Untestable TP's (1)

Test Purpose	Reference to ETS 300 497-9
TP/FT/MM/BV/PR-01	
TP/FT/IS/BV-01	
TP/FT/IS/BV-02	
TP/FT/IS/BV-03	
TP/FT/CL/BV-01	
TP/FT/CL/BV-02	
TP/FT/CL/BV-03	

6 ATS Conventions

The ATS conventions are intended to give a better understanding of the ATS but they describe also the conventions made for the development of the ATS. Thus for any later maintenance purposes or further development of the ATS the conventions described in this clause shall be considered.

The ATS conventions contain two clauses, the naming conventions and the implementation conventions. The naming conventions describe the structure of the naming of all ATS elements. The implementation conventions describe the functional structure of the ATS.

To define the ATS the guidelines of the documents ETS 300 406 [10] and ETR 141 were considered.

6.1 Naming conventions

6.1.1 Declarations part

This subclause describes the naming conventions chosen for the elements of the ATS declarations part. The following general rules apply:

- identifiers shall be written in lowercase;
- type declarations shall be written in uppercase;
- constraints shall be written with the first letter in uppercase, and the rest in lowercase.

Information elements are coded in the order from top to bottom and from right to left, in order to make the encoding and decoding easier.

6.1.1.1 Test suite type, ASP and PDU type definitions

The test suite type-definitions, the ASP type definitions and the PDU type definitions shall be written in uppercase. Identifier names of structured type definitions and of the ASP and PDU type definitions, shall be written in lowercase.

Types related to a certain higher layer entity shall commence with a protocol identifier to define which entity they belong to.

EXAMPLE 1: Call Control: cc e.g. CC_SETUP.

Id names of structured types which are used for invalid tests commence with "bi":

EXAMPLE 2: Bi_cc_setup_rx01.

6.1.1.2 Test Suite Operations (TSO) definitions

The TSO identifiers are composed of a string in uppercase letters starting by the string "TSO_" (e.g. TSO_INTEGER_TO_O_1).

6.1.1.3 Test Suite Parameter (TSP) declarations

The TSP identifiers are composed of a string in uppercase letters starting by the string "TSP_" (e.g. TSP_WINDOW_SIZE).

If the TSP references a Protocol Implementation Conformance Statement (PICS) item, the letter "C" is added to the standard prefix (e.g. TSPC_PICS_ITEM_S23).

If the TSP references a PIXIT item, the letter "X" is added to the standard prefix (e.g. TSPX_PIXIT_ITEM_2).

Exception: If the TSP represents a system parameter or value, only the name defined in the specifications is used (e.g. V_S = send sequence variable).

Complete names as defined in the specifications are used.

6.1.1.4 Test Case Selection (TCS) expression definitions

The naming conventions for the TCS expression definitions use almost the same rules as the TSPs, except for the prefix that is "TCS_". Also they are logical combinations of the TSP definitions.

6.1.1.5 Test Suite Constant (TSC) declarations

The TSC identifiers are composed of a string in uppercase letters starting by the string "TSC_" (e.g. TSC_retry).

Exception: If the TSC represents a system parameter or value, only the name defined in the specifications is used (e.g. N250).

Complete names as defined in the specifications are used.

6.1.1.6 Test Suite Variable (TSV) declarations

The TSV identifiers are composed of a string in uppercase letters starting by the string "TSV_".

Complete names as defined in the specifications are used.

6.1.1.7 Test Case Variable (TCV) declarations

The TCV identifiers are composed of a string in uppercase letters starting by the string "TCV_".

EXAMPLE: TCV_crvalue.

Complete names as defined in the specifications are used.

6.1.1.8 Point of Control and Observation (PCO) declarations

The PCO identifiers are composed of two or four capital letters, beginning with "L", as there are only LTs.

EXAMPLE: LMAC represents a PCO on Medium Access Control (MAC) interface as LT in the test equipment;
LDLC represents a PCO on DLC interface as LT in the test equipment.

6.1.1.9 Timer declarations

Two types of timers can be identified:

- 1) standardised:
 - those defined in the standard, e.g. T302. They use exactly the same name as in the standard, beginning with a capital "T".
 - As there is a tolerance margin accepted for these timers, three values are needed:
 - the maximum value allowed, which will use the suffix "_max";
 - the minimum value allowed, which will use the suffix "_min";
 - the value actually implemented, with no suffix;

EXAMPLE 1: T302_max, T302_min, and T302.

- 2) not standardised:

- those not defined in the standard, i.e. for execution use, e. g. a timer waiting for a response. These timers begin with the prefix "T_", followed by a string in capital letters.

EXAMPLE 2: T_RESP represents a timer for controlling the response time of the IUT.

6.1.1.10 ASP type definitions

The identifier of an ASP uses exactly the same name as the name defined in the specifications. It is written in uppercases, finishing by an underscore character ("_"), and three capital letters indicating whether it is a request, an indication, a response or a confirmation primitive.

EXAMPLE: DL-RELEASE_REQ for an ASP containing a layer 3 release request passed to layer 2;
MAC-CO_DATA_REQ for an ASP containing a layer 2b PDU passed to layer 2a.

6.1.1.11 PDU type definitions

The identifier of a PDU is given in a string in uppercase letters, representing the layer message.

EXAMPLE 1: rr for the Receive Ready layer 2 message;
disconnect for the DISCONNECT layer 3 message.

Where the message is a composite word, an underscore character ("_") appears in the string.

EXAMPLE 2: release_complete is the RELEASE COMPLETE layer 3 message.

Id names of PDUs commence with a protocol identifier to define which protocol they are belonging to. The following identifiers are used:

- Call Control: cc e.g. CC-SETUP.

Id names of PDUs which are used for invalid tests commence with "bi":

EXAMPLE 3: BI-CC-SETUP.

6.1.1.12 Alias definitions

These are used to make the sending and receiving of PDUs within ASPs more understandable when writing the dynamic part of the test suite. This is done by giving the ASP an alias. The alias name indicates the PDU carried by the ASP and whether it is sent or received by the tester.

The identifier of an alias consists of a string in capital letters indicating the message, followed by two lower case letters "r" or "s" indicating if the message should be sent or received by the tester.

6.1.2 Constraints part

This subclause describes the naming conventions chosen for the elements of the ATS constraints part.

Constraint identifiers commence with uppercase. The remaining part of the Id name is written in lowercase.

Identifier names of elements concerning the same subject have equivalent names in the Declaration and the Constraint part:

Declaration Part:	cc_setup;
Constraint Part:	Cc_setup.

The name of the modified constraint describes the particularity of the modified constraint:

EXAMPLE: Cc_setup_mand_only (modified Cc_setup with only the mandatory Information Elements).

If formal parameter lists are used, the variable names are written in lowercase. The variable name is the same as the name of the element it is representing.

Structured type constraints declarations are divided into:

- receive constraints:
 - the receive constraints are noted down as "name_rx*". The receive constraints are subdivided into:
 - receive base constraints:

they are noted down as "name_rx_base";
 - receive special constraints:

they are noted down as "name_rx_<extension>", where <extension> is a descriptive name (e.g. "Signal_rx_alerting_on");
- transmit constraints:
 - the transmit constraints are noted down as "name_tx_<extension>", where <extension> is a descriptive name. (e.g. "Signal_tx_alerting_off").

If a certain structured type constraint is valid for both receiving and transmitting, because it contains no wildcards, and the receiving constraint should exactly match, the constraint will be noted down as:

"<structured_type_name>_extention" Example: "Portable_id_ipui".

PDU Constraints Declarations are divided into:

- receive constraints:
 - the receive constraints are noted down as "name_rx*". The receive constraints are subdivided into:
 - receive base constraints:
 - they are noted down as "name_rx_base". They constrain all allowed values, and for the optional fields, the "IF_PRESENT" keyword is added;
 - receive special constraints:
 - they are noted down as "name_rx0n", where n is a sequence number;
- transmit constraints:
 - the transmit constraints are noted down as "name_tx", where n is a sequence number. They can be subdivided into:
 - transmit base constraints:
 - they are noted down as "name_tx_base". They constrain all mandatory fields to all allowed values in the standard, and they constrain all optional fields to "OMIT";
 - transmit special constraints:
 - they are noted down as "name_tx0n" where n is a sequence number. They shall not contain any wildcards.

Derived constraints shall not be more than 1 level deep. They shall only be derived directly from the base constraint.

The test suite is not ready yet to handle PDU's with empty information elements. For every receive constraint, also a information element constraint with an empty parameter list should be added.

6.1.3 Dynamic part

This subclause describes the naming conventions chosen for the elements of the ATS dynamic part.

6.1.3.1 Test Case (TC) identifier

The identifier of the TCs is built in the same way as for the TP described in ETS 300 324-3 [9], subclause 5.1.1, with the exception that "TP" is replaced by "TC":

- TP identifier: TPCCBI-04;
- TC identifier: TCCCBI-04.

6.1.3.2 Test Step (TS) identifier

The TS identifier is built with two strings of capital letters joined by underscore character. The first string indicates the main function of the TS; e.g. PR for preamble, PO for postamble, CS for check state and STP for general step. The second string indicates the meaning of the step.

In some TCs, test steps as well as local trees can be used. To allow an easy distinguishing of them the following naming applies:

LTS_[local_tree_name]	local tree;
STP_[test_step_name]	test step.

6.1.3.3 Default identifier

The default identifiers begin with the prefix "DF_", followed by a string in capital letters.

6.1.3.4 General aspects

All verdict assignments are labelled. To allow an exact identification in which table the verdict was assigned, the following name convention is applied:

B	test Body
CS	Check State test steps
D	Default
E	Error handling test steps
PO	POstamble
PR	PReamble
S	test Step

Also combinations of labels are possible:

EXAMPLE: DPR --> label which is used in a default for preambles.

6.1.3.5 ATS abbreviations

These abbreviations are used to shorten identifier names:

ack	acknowledgement
auth	authentication
algo	algorithm
cc	call control
cfm	confirm
est	establish
ext	extension
id	identification
ind	indication
info	information
max	maximum
min	minimum
prop	proprietary
req	request
res	response

The following keywords will NOT be abbreviated in identifier names:

address(es);
 attribute(s);
 identity;
 number(s);
 character(s).

6.2 Implementation conventions

6.2.1 Declaration part

The comment line of single element Tree and Tabular Combined Notation (TTCN) tables (e.g. test suite constants) is used to give a reference where the format and content of the element is described in the relevant protocol specifications. Any particularity of the element format or content is described in the comment line.

The comment line in the header of multi element TTCN tables (e.g. ASPs) is used to reference to the protocol specification. The detailed comments are used to describe any particularity of the table.

In the ASP and PDU declarations, the comments column is used to identify if an element is mandatory or optional:

m: mandatory;
o: optional.

In the ASP and PDU declarations the comments column is further used to give information about the element value, in particular if the element contains a fixed spare value.

In tables where structure types are used the information element and the relevant structured type have always the same name, that allows to have the same structure as in the protocol standards is used to document the relation between information elements in a table and their specific description in an other clause of the protocol standard.

The following conventions apply to identifier names in the structured type definitions part:

- bits of bit sequences having a fixed value, meant to fill up the octet, are called fn, where n stands for the octet number;
- extension flags, will be called extn, where n stands for the octet number.

6.2.2 Constraint part

The ASPs and PDUs are defined in a way that all relevant element are parametrized. That improves the transparency of the constraints in the dynamic part, as all values which are relevant for the test are always present.

Generally no modified constraints are used, this allows an easier reuse and adaptation of constraints if they are reused in other DECT profile test specifications.

The Comment line of a constraint contains always the reference to the used specifications.

The detailed comments sector is used to describe any particularity of the table.

6.2.3 Dynamic part

Some TCs need a particular initialisation of the IUT environment conditions to run the actual test, e.g. for testing re-provisioning procedures. Such message sequence can be quite complicated and long. In cases where a Local Test Step (LTS) facilitates the TC structure, the preamble and the condition setting are described in a LTS called LTS_pre_step. All LTS_pre_steps are described in the detailed comment part of the TTCN table.

Some TCs need after the actual test a particular re-initialization of the IUT, e.g. after re-provisioning. Such message sequence can be quite complicated and long. In cases where a Local Test Step (LTS) facilitates the TC structure, the postamble and the re-initialization are described in a LTS called LTS_post_step. All LTS_post_steps are described in the detailed comment part of the TTCN table.

All events which are defined as a conformance requirements by the TP, cause a preliminary verdict PASS if the requirement is met.

All invalid events are handled in the default tree. FAIL verdicts are only assigned in the default tree.

The preamble, the test body and the postamble have different defaults, what allows a specific verdict handling, e.g. only INCONC verdicts are assigned in the preamble.

Test steps do not contain a default. That allows to apply them with no restrictions regarding the error handling.

All verdict assignments are labelled. According to ISO/IEC 9646-3 [14], annex E.2, labels should be written to the conformance log. This allows to identify where the test failed. To allow an exact identification in which table the verdict was assigned, the naming convention as described in subclause 6.1.3.3 is applied.

The labels of the same type are numbered sequentially if they are in the same TC, test step or default.

TP which are listed in the untestable TP list in Clause 5, or which reference to an other TP, e.g. BV TP which were already defined as capability TP, are not considered in the ATS, thus these TC identifiers are missing in the ATS and the numbering of the TCs is not always continues.

6.2.4 Documentation

The Comment line of the TC or test step header contains a reference to the relevant protocol specification.

The Comment column of the dynamic behaviour part is used to number the test events which are relevant for the particular test or test operation.

Based on the numbering in the comment column all for the TC relevant events are described in the Detailed Comments part of each TTCN table.

Test procedures which cover a conformance requirement and lead to a preliminary or final verdict assignment are described as follows in the Detailed Comments part:

Expected event: a specific receive event is expected.

Expected behaviour: no event or a timer expiry is expected.

Expected status: the IUT is expected to be in a particular status.

6.2.5 Coding of some information elements

Due to special requirements of using shift information elements in DECT messages these are not described in the TTCN.

For the rules of incorporating "shift" information elements in a message see ETS 300 175-5 [5] shift procedure, subclauses 7.5.2, 7.5.3 and 7.5.4 (e.g. a shift may appear at any place in a message, locking shift may shift only to higher code set, a non locking shift indicating the current codeset shall not constitute an error, etc).

Annex A (normative): Abstract test suite for NWK testing

The ATS is written in TTCN according to ISO/IEC 9646-3 [14].

As the ATS was developed on a separate TTCN tool the TTCN tables are not completely referenced in the contents table. The ATS itself contains a subclause Test Suite Overview which provides additional information and references about the ATS.

NOTE: According to ISO/IEC 9646-3 [14], in case of a conflict in interpretation of the operational semantics of TTCN.GR and TTCN.MP, the operational semantics of the TTCN.GR representation takes precedence.

A.1 The machine processable ATS (TTCN.MP)

The electronic form of the machine processable file (TTCN MP format) corresponding to this ATS is contained in an ASCII text file (4979_ev.MP (note)) associated with this ETS.

NOTE: This file is located in a compressed archive file named 4979_ev.LZH. Other file formats are available on request.

A.2 The graphical ATS (TTCN.GR)

The electronic form of the graphical ATS (TTCN GR format) corresponding to this ATS is contained in an ASCII Postscript file (4979_ev.PS (note)) associated with this ETS.

NOTE: This file is located in a compressed archive file named 4979_ev.LZH. Other file formats are available on request.

Annex B (normative): Partial PIXIT proforma

Notwithstanding the provisions of the copyright clause related to the text of this ETS, ETSI grants that users of this ETS may freely reproduce the PIXIT proforma in this annex so that it can be used for its intended purposes and may further publish the completed PIXIT.

The PIXIT Proforma is based on ISO/IEC 9646-6 [17]. Any additional information needed can be found in this international standard document.

B.1 Identification summary**Table B.1**

PIXIT Number:	
Test Laboratory Name:	
Date of Issue:	
Issued to:	

B.2 ATS summary**Table B.2**

Protocol Specification:	
Protocol to be tested:	
ATS Specification:	
Abstract Test Method:	Embedded variant of the Remote Test Method with no UT

B.3 Test laboratory**Table B.3**

Test Laboratory Identification:	
Test Laboratory Manager:	
Means of Testing:	
SAP Address:	

B.4 Client identification**Table B.4**

Client Identification:	
Client Test manager:	
Test Facilities required:	

B.5 SUT**Table B.5**

Name:	
Version:	
SCS Number:	
Machine configuration:	
Operating System Identification:	
IUT Identification:	
PICS Reference for IUT:	
Limitations of the SUT:	
Environmental Conditions:	

B.6 Protocol layer information

B.6.1 Protocol identification

Table B.6

Name:	DECT - Network Layer
Version:	
PICS References:	

B.6.2 IUT information

Table B.7: General configuration

Item	Parameter	Parameter type	Explanation and ETS reference	Value
1	TSPX_mmproc_aupt_cc state	CCSTATE_TYPE (INTEGER 0, 1, 2, 3, 4, 6, 7, 10, 19)	Indicates the FT cc state, the authentication of PT testcases shall be tested in. Ref. ETS 300 175 [5], subclause 13.5	
2	TSPX_mmproc_auus_c cstate	CCSTATE_TYPE (INTEGER 0, 1, 2, 3, 4, 6, 7, 10, 19)	Indicates the FT cc state, the User authentication test cases shall be tested in. Ref. ETS 300 175 [5], subclause 13.5	
3	TSPX_mmproc_cift_ccstate	CCSTATE_TYPE (INTEGER 0, 1, 2, 3, 4, 6, 7, 10, 19)	Indicates the FT cc state, the FT init. cipherying test cases shall be tested in. Ref. ETS 300 175 [5], subclause 13.5	
4	TSPX_mmproc_idpt_ccstate	CCSTATE_TYPE (INTEGER 0, 1, 2, 3, 4, 6, 7, 10, 19)	Indicates the FT cc state, the Identification of PT test cases shall be tested in. Ref. ETS 300 175 [5], subclause 13.5	
5	TSPX_mmproc_loup_cc state	CCSTATE_TYPE (INTEGER 0, 1, 2, 3, 4, 6, 7, 10, 19)	Indicates the FT cc state, the location update test cases shall be tested in. Ref. ETS 300 175 [5], subclause 13.5	
6	TSPX_mmproc_keal_cc state	CCSTATE_TYPE (INTEGER 0, 1, 2, 3, 4, 6, 7, 10, 19)	Indicates the FT cc state, the key allocation test cases shall be tested in. Ref. ETS 300 175 [5], subclause 13.5	
7	TSPX_mmproc_arte_invoke	MMPROC_TYPE (INTEGER 0 .. 10)	Indicates the way of invoking the access rights terminate proc. Ref. ETS 300 175 [5], subclause 13.5	
8	TSPX_mmproc_aupt_invoke	MMPROC_TYPE (INTEGER 0 .. 10)	Indicates the way of invoking the authentication of PT proc. Ref. ETS 300 175 [5], subclause 13.5	
9	TSPX_mmproc_auus_invoke	MMPROC_TYPE (INTEGER 0 .. 10)	Indicates the way of invoking the authentication of user proc. Ref. ETS 300 175 [5], subclause 13.5	
10	TSPX_mmproc_cift_invoke	MMPROC_TYPE (INTEGER 0 .. 10)	Indicates the way of invoking the FT initiated cipherying proc. Ref. ETS 300 175 [5], subclause 13.5	

(continued)

Table B.7: (concluded) General configuration

Item	Parameter	Parameter type	Explanation and ETS reference	Value
11	TSPX_mmproc_idpt_invoke	MMPROC_TYPE (INTEGER 0 .. 10)	Indicates the way of invoking the identification of PT proc. Ref. ETS 300 175 [5], subclause 13.5	
12	TSPX_mmproc_loup_invoke	MMPROC_TYPE (INTEGER 0 .. 10)	Indicates the way of invoking the location update proc. Ref. ETS 300 175 [5], subclause 13.5	
13	TSPX_mmproc_keal_invoke	MMPROC_TYPE (INTEGER 0 .. 10)	Indicates the way of invoking the key allocation proc. Ref. ETS 300 175 [5], subclause 13.5	
14	TSPX_nr_of_digits_in_cpn	CPN_LENGTH_TYPE	This parameter is related to parameter TSPX_called_party_number. It specifies the actual number of digits present in the cpn.	
15	TSPX_access_rights_uak	BOOLEAN	TRUE if IUT supports Obtain of access rights procedure with Auth_Key_Type = 1 (User Authentication Key (UAK))	
16	TSPX_set_bit_a38	BOOLEAN	Can "higher layer capabilities" bit a38 be set dynamically on the IUT by the test operator.	
17	TSPX_lce_02	INTEGER	Value of Timer <LCE_02> in milliseconds	
18	TSPX_mmproc_arte_revoked	MMPROC_TYPE	Indicates the way of revoking the accessrights of a PT.	
19	TSPX_some_digits	DECT_1_255	To give a few digits to be used with the tests for dialing pause, go to DTMF, etc...	
20	TSPX_some_digits_length	OCT_1	To identify how many digits are provided in TSPX_some_digits	
21	TSPX_basic_digits	OCT_1	To give the order of the basic digits to be used as to have to use all from 0123456789*#	
22	TSPX_change_f02	BOOLEAN	TRUE if the IUT waits for more than one dialling digit to be received before it changes the F-02 state.	

Table B.8: Addresses

Item	Address name	Parameter type	Explanation and ETS reference	Value
1	TSPX_decimal_ac_value	OCT_4 (OCTETSTRING[4])	Value of Authentication Code (AC) to be used. The AC will be entered as maximal 8 decimal digits. The AC to bitstring mapping will be done with operator TSO_cinft_convert_ac_to_bitstring. Ref. ETS 300 444 [11], subclause 14.2	
2	TSPX_complete_fixed_id_ari_value	FIXED_ID_VALUE_TYPE (BITSTRING[8..72])	Value of fixed_id to be used in case of ARI. Ref. ETS 300 175-5 [5], subclause 7.7.18	
3	TSPX_complete_fixed_id_ari_rpn_value	FIXED_ID_VALUE_TYPE (BITSTRING[8..72])	Value of fixed_id to be used in case of ARI + RPN, 40 bits long including fill bits. Ref. ETS 300 175 [5], subclause 7.7.18	
4	TSPX_dlei_value	DATA_LINK_ENDPOINT_IDENTIFIER (INTEGER)	Value of data link endpoint identifier to be used in the test system (local test system matter)	
5	TSPX_ipei_value	PORT_ID_VALUE_TYPE (BITSTRING[8..104])	Value of International Portable Equipment Identity (IPEI) (IPEI-N) to be expected from the IUT (before subscription), 40 bits value is required including fill bits. Ref. ETS 300 175 [5], subclause 7.7.30	
6	TSPX_ipui_value	PORT_ID_VALUE_TYPE (BITSTRING[8..104])	Value of International Portable User Identity (IPEI) to be used by the PT (LT) (after subscription). The 4 first bits represent the type of IPEI. The following bits are the IPEI coded in BCD or in binary depending on the type. Ref. ETS 300 175 [5], subclause 7.7.30	
7	TSPX_location_area_level	BIT_6 (BITSTRING[6])	The location area level that is going to be used. Ref. ETS 300 175 [5], subclause 7.7.25	
8	TSPX_complete_fixed_id_park_value	FIXED_ID_VALUE_TYPE (BITSTRING[8..72])	Value of fixed_id to be used in case of Portable Access Rights Key (PARK). Ref. ETS 300 175 [5], subclause 7.7.18	
9	TSPX_tpui_value	PORT_ID_VALUE_TYPE (BITSTRING[8..104])	Value of tpui to be used by the PT(LT). 20 bits value is required., Ref. ETS 300 175 [5], subclause 7.7.30	

(continued)

Table B.8: (concluded) Addresses

Item	Address name	Parameter type	Explanation and ETS reference	Value
10	TSPX_decimal_upi_value	OCT_4 (OCTETSTRING[4])	Value of UPI to be used. The UPI will be entered as maximal 8 decimal digits. The UPI to bitstring mapping will be done with operation TSO_cinft_convert_upi_to_bitstring. Ref. ETS 300 444 [11], subclause 8.22	
11	TSPX_park_length_indicator	INTEGER	The number of significant bits of the PARK value(PLI).(specified in TSPX_complete_fixed_id_park_value)	
12	TSPX_ari_length_indicator	INTEGER	The number of significant bits of the ARI value. (specified in TSPX_complete_fixed_id_ari_value)	
13	TSPX_called_party_number	OCT_1_14	The called party number to be dialled by the PT (LT) in order to get connection to the network. For practical reasons, the number is limited to 14 digits,	
14	TSPX_emergency_cpn	OCT_1_14	The emergency called party number to be dialled by the PT (LT) in order to get connection to the network. For practical reasons, the number is limited to 14 digits,	
15	TSPX_calling_party_number	DECT_1_14	Calling party number which IUT is expected to include in incoming call to tester. For practical reasons the number is limited to 14 digits.	

Table B.9: Implicit send events

Item	PIXIT (see note)	Related implicit send message (PDU)	Indication how the implicit send event can be invoked
1	TSPX_invoke_access_termin_req	To invoke the FT initiated terminate access rights procedure. A dl_data_indication is to be expected, containing an ACCESS_RIGHTS_TERM_REQUEST message. Expected Constraint: Access_rights_term_req_rx_base	
2	TSPX_invoke_pt_authentication	To invoke the FT initiated PT authentication procedure. A dl_data_indication is to be expected, containing an AUTH_REQUEST message. Expected Constraint: Auth_request_rx01	
3	TSPX_invoke_user_authentication	To invoke the FT initiated user authentication procedure. A dl_data_indication is to be expected, containing an AUTH_REQUEST message with UPI. Expected Constraint: Auth_request_rx03	
4	TSPX_invoke_pt_auth_with_zap	To invoke the FT initiated PT authentication procedure. A dl_data_indication is to be expected, containing an AUTH_REQUEST message. The AUTH_REQUEST message shall contain the <<auth_type>>.i.e. with ZAP_increment bit set to 1. Expected Constraint: Auth_request_rx02	
5	TSPX_invoke_ft_init_ciphering_off	To invoke the FT to initiate ciphering off. A dl_data_ind is expected, containing a CIPHER-REQUEST PDU. Expected Constraint: Cipher_request_rx02	
6	TSPX_invoke_ft_init_ciphering_on	A dl_data_ind is expected, containing a CIPHER-REQUEST PDU. Expected Constraint: Cipher_request_rx01	
7	TSPX_invoke_incoming_call	To invoke the IUT to initiate a normal incoming call setup, while in state F-00. Precondition: Timer T_USER_INVOKE is started. It will be cancelled when the link is established. Expected Constraint: Lce_request_page_rx01	

(continued)

Table B.9: (concluded) Implicit send events

Item	PIXIT (see note)	Related implicit send message (PDU)	Indication how the implicit send event can be invoked
8	TSPX_invoke_identity_req	To invoke the FT to initiate identity request. A dl_data_ind is expected, containing a IDENTITY-REQUEST PDU. Expected Constraint: Identity_request_rx_base	
9	TSPX_invoke_normal_release	To invoke the IUT to go on hook, thus initiating a normal release, while in any cc state. A dl_data_indication is to be expected, containing a CC_RELEASE message. Expected Constraint: Cc_release_rx_base This indicates as well whether the IUT supports invocation of normal release.	
10	TSPX_invoke_key_allocation	To invoke a key allocation procedure initiated by the FT side. Expected Constraint: Allocation_type_rx_dsaa	
11	TSPX_invoke_location_update	To initiate the FT initiated location update procedure. A dl_data_indication is to be expected, containing an MM_INFO_SUGGEST message. Expected Constraint: Mm_info_suggest_rx_base	
12	TSPX_invoke_partial_release	To invoke the IUT to initiate a partial release. A precondition to the execution of this test step is, that a link exists and a CC transaction is in progress/active between the It and the iut. Expected Constraint: Cc_release_rx_base	
13	TSPX__invoke_call_answering	To invoke the IUT to answer the call by sending a CC-CONNECT message. Expected constraint: Cc_connect_rx_base	

NOTE: The PIXIT names are related to the test steps where the Implicit send events are handled, e.g. the PIXIT TSPX_invoke_abnormal_release is related to the test step STP_invoke_abnormal_release.

Annex C (normative): Protocol Conformance Test Report (PCTR) Proforma for DECT NWK

Notwithstanding the provisions of the copyright clause related to the text of this ETS, ETSI grants that users of this ETS may freely reproduce the PCTR proforma in this annex so that it can be used for its intended purposes and may further publish the completed PCTR.

The PCTR Proforma is based on ISO/IEC 9646-6. Any additional information needed can be found in this document.

C.1 Identification summary

C.1.1 Protocol conformance test report

Table C.1

PCTR Number:	
PCTR Date:	
Corresponding SCTR Number:	
Corresponding SCTR Date:	
Test Laboratory Identification:	
Test Laboratory Manager:	
Signature:	

C.1.2 IUT identification

Table C.2

Name:	
Version:	
Protocol specification:	
PICS:	
Previous PCTR if any:	

C.1.3 Testing environment

Table C.3

PIXIT Number:	
ATS Specification:	
Abstract Test Method:	Remote test method, Embedded variant with no UT
Means of Testing identification:	
Date of testing:	
Conformance Log reference(s):	
Retention Date for Log reference(s):	

C.1.4 Limits and reservation

Additional information relevant to the technical contents or further use of the test report, or the rights and obligations of the test laboratory and the client, may be given here. Such information may include restriction on the publication of the report.

.....

C.1.5 Comments

Additional comments may be given by either the client or the test laboratory on any of the contents of the PCTR, for example, to note disagreement between the two parties.

.....
.....
.....
.....
.....

C.2 IUT Conformance status

This IUT has or has not been shown by conformance assessment to be non conforming to the specified protocol specification.

Strike the appropriate words in this sentence. If the PICS for this IUT is consistent with the static conformance requirements (as specified in Clause 3 in this report) and there are no "FAIL" verdicts to be recorded (in Clause 6) strike the words "has or". otherwise strike the words "or has not".

C.3 Static conformance summary

The PICS for this IUT is or is not consistent with the static conformance requirements in the specified protocol.

Strike the appropriate words in this sentence.

C.4 Dynamic conformance summary

The test campaign did or did not reveal errors in the IUT.

Strike the appropriate words in this sentence. If there are no "FAIL" verdicts to be recorded (in clause 6 of this report) strike the words "did or". otherwise strike the words "or did not".

Summary of the results of groups of test:

.....
.....
.....
.....
.....
.....
.....

C.5 Static conformance review report

If clause 3 indicates non-conformance, this subclause itemises the mismatches between the PICS and the static conformance requirements of the specified protocol specification.

.....
.....
.....
.....
.....
.....
.....
.....

C.6 Test campaign report

ATS reference	Selected?	Run?	Verdict	Observations (Reference to any observations made in clause 7)
TC_FT_CC_BV_OC_01	Yes/No	Yes/No		
TC_FT_CC_BV_OC_02	Yes/No	Yes/No		
TC_FT_CC_BV_OC_03	Yes/No	Yes/No		
TC_FT_CC_BV_OC_04	Yes/No	Yes/No		
TC_FT_CC_BV_OC_05	Yes/No	Yes/No		
TC_FT_CC_BV_IC_01	Yes/No	Yes/No		
TC_FT_CC_BV_IC_02	Yes/No	Yes/No		
TC_FT_CC_BV_CI_01	Yes/No	Yes/No		
TC_FT_CC_BV_CI_02	Yes/No	Yes/No		
TC_FT_CC_BV_CI_03	Yes/No	Yes/No		
TC_FT_CC_BV_CI_04	Yes/No	Yes/No		
TC_FT_CC_BV_CI_05	Yes/No	Yes/No		
TC_FT_CC_BV_CI_06	Yes/No	Yes/No		
TC_FT_CC_BV_CI_07	Yes/No	Yes/No		
TC_FT_CC_BV_CI_08	Yes/No	Yes/No		
TC_FT_CC_BV_CI_09	Yes/No	Yes/No		
TC_FT_CC_BV_CI_10	Yes/No	Yes/No		
TC_FT_CC_BV_CR_01	Yes/No	Yes/No		
TC_FT_CC_BV_CR_02	Yes/No	Yes/No		
TC_FT_CC_BV_CR_03	Yes/No	Yes/No		
TC_FT_CC_BV_CR_04	Yes/No	Yes/No		
TC_FT_CC_BV_CR_05	Yes/No	Yes/No		
TC_FT_CC_BV_CR_06	Yes/No	Yes/No		
TC_FT_CC_BV_CR_07	Yes/No	Yes/No		
TC_FT_CC_BV_CR_08	Yes/No	Yes/No		
TC_FT_CC_BV_CR_09	Yes/No	Yes/No		
TC_FT_CC_BV_CR_10	Yes/No	Yes/No		
TC_FT_CC_BV_RS_07	Yes/No	Yes/No		
TC_FT_CC_BV_BO_01	Yes/No	Yes/No		
TC_FT_CC_BV_BO_02	Yes/No	Yes/No		
TC_FT_CC_BI_01	Yes/No	Yes/No		
TC_FT_CC_BI_02	Yes/No	Yes/No		
TC_FT_CC_BI_03	Yes/No	Yes/No		
TC_FT_CC_TI_01	Yes/No	Yes/No		
TC_FT_CC_TI_02	Yes/No	Yes/No		
TC_FT_CC_TI_03	Yes/No	Yes/No		
TC_FT_CC_TI_04	Yes/No	Yes/No		
TC_FT_MM_BV_ID_01	Yes/No	Yes/No		
TC_FT_MM_BV_AU_01	Yes/No	Yes/No		
TC_FT_MM_BV_AU_02	Yes/No	Yes/No		
TC_FT_MM_BV_AU_03	Yes/No	Yes/No		
TC_FT_MM_BV_AU_04	Yes/No	Yes/No		
TC_FT_MM_BV_AU_05	Yes/No	Yes/No		
TC_FT_MM_BV_AU_06	Yes/No	Yes/No		
TC_FT_MM_BV_LO_01	Yes/No	Yes/No		
TC_FT_MM_BV_LO_02	Yes/No	Yes/No		
TC_FT_MM_BV_LO_03	Yes/No	Yes/No		
TC_FT_MM_BV_LO_05	Yes/No	Yes/No		
TC_FT_MM_BV_LO_06	Yes/No	Yes/No		

(continued)

(concluded)

ATS reference	Selected?	Run?	Verdict	Observations (Reference to any observations made in clause 7)
TC_FT_MM_BV_LO_07	Yes/No	Yes/No		
TC_FT_MM_BV_AR_01	Yes/No	Yes/No		
TC_FT_MM_BV_AR_02	Yes/No	Yes/No		
TC_FT_MM_BV_AR_03	Yes/No	Yes/No		
TC_FT_MM_BV_AR_06	Yes/No	Yes/No		
TC_FT_MM_BV_AR_07	Yes/No	Yes/No		
TC_FT_MM_BV_KA_01	Yes/No	Yes/No		
TC_FT_MM_BV_KA_02	Yes/No	Yes/No		
TC_FT_MM_BV_CH_01	Yes/No	Yes/No		
TC_FT_MM_BV_CH_02	Yes/No	Yes/No		
TC_FT_MM_BV_CH_03	Yes/No	Yes/No		
TC_FT_MM_BV_CH_04	Yes/No	Yes/No		
TC_FT_MM_BV_CH_05	Yes/No	Yes/No		
TC_FT_MM_BV_CH_08	Yes/No	Yes/No		
TC_FT_MM_BV_CH_09	Yes/No	Yes/No		
TC_FT_MM_BV_CH_10	Yes/No	Yes/No		
TC_FT_MM_BV_CH_11	Yes/No	Yes/No		
TC_FT_MM_BV_CH_12	Yes/No	Yes/No		
TC_FT_MM_BV_CH_13	Yes/No	Yes/No		
TC_FT_MM_BV_CH_14	Yes/No	Yes/No		
TC_FT_MM_BV_CH_15	Yes/No	Yes/No		
TC_FT_MM_BO_01	Yes/No	Yes/No		
TC_FT_MM_BI_02	Yes/No	Yes/No		
TC_FT_MM_BI_03	Yes/No	Yes/No		
TC_FT_MM_TI_01	Yes/No	Yes/No		
TC_FT_MM_TI_02	Yes/No	Yes/No		
TC_FT_MM_TI_03	Yes/No	Yes/No		
TC_FT_MM_TI_04	Yes/No	Yes/No		
TC_FT_MM_TI_05	Yes/No	Yes/No		
TC_FT_MM_TI_06	Yes/No	Yes/No		
TC_FT_MM_TI_07	Yes/No	Yes/No		
TC_FT_ME_BV_01	Yes/No	Yes/No		
TC_FT_ME_BV_02	Yes/No	Yes/No		
TC_FT_ME_BV_03	Yes/No	Yes/No		
TC_FT_LC_BV_LE_01	Yes/No	Yes/No		
TC_FT_LC_BV_LE_02	Yes/No	Yes/No		
TC_FT_LC_BV_LE_03	Yes/No	Yes/No		
TC_FT_LC_BV_LR_01	Yes/No	Yes/No		
TC_FT_LC_BV_LR_02	Yes/No	Yes/No		
TC_FT_LC_BV_LR_03	Yes/No	Yes/No		
TC_FT_LC_BV_LR_04	Yes/No	Yes/No		
TC_FT_LC_BI_01	Yes/No	Yes/No		
TC_FT_LC_BI_04	Yes/No	Yes/No		
TC_FT_LC_BI_05	Yes/No	Yes/No		
TC_FT_LC_BI_07	Yes/No	Yes/No		
TC_FT_LC_TI_02	Yes/No	Yes/No		

C.7 Observations

Additional information relevant to the technical content of the PCTR are given here.

.....
.....
.....
.....
.....
.....
.....
.....
.....
.....

Annex D (informative): Bibliography

- 1) EWOS/ETSI Project Team No 5: "Project Report and Technical Report. OSI Conformance Testing Methodology and Procedures in Europe".
- 2) ETR 022: "Advanced Testing Methods (ATM); Vocabulary of terms used in communications protocols conformance testing".
- 3) ETR 141: "Methods for Testing and Specification (MTS); Protocol and profile conformance testing specifications; The Tree and Tabular Combined Notation (TTCN) style guide".
- 4) CEPT Recommendation T/SGT SF2 (89) 6/0: "Draft Recommendation T/SF Services and Facilities of Digital Enhanced Cordless Telecommunications".
- 5) ETR 015: "Digital Enhanced Cordless Telecommunications (DECT); Reference document".
- 6) ETR 041: "Transmission and Multiplexing (TM); Digital Enhanced Cordless Telecommunications (DECT); Transmission aspects 3,1 kHz telephony Interworking with other networks".
- 7) ETR 042: "Digital Enhanced Cordless Telecommunications (DECT); A Guide to DECT features that influence the traffic capacity and the maintenance of high radio link transmission quality, including the results of simulations".
- 8) ETR 043: "Digital Enhanced Cordless Telecommunications (DECT); Common interface; Services and Facilities requirements specification".
- 9) ETR 056: "Digital Enhanced Cordless Telecommunications (DECT); System description document".

History

Document history			
August 1996	First Edition		
February 1997	Public Enquiry	PE 9724:	1997-02-14 to 1997-06-13
November 1997	Vote	V 9803:	1997-11-18 to 1998-01-16