



EUROPEAN
TELECOMMUNICATION
STANDARD

DRAFT
pr **ETS 300 497-5**

February 1997

Second Edition

Source: ETSI EP-DECT

Reference: RE/DECT-040094-5

ICS: 33.020

Key words: ATS, DECT, DLC

**Radio Equipment and Systems (RES);
Digital Enhanced Cordless Telecommunications (DECT);
Common Interface (CI) Test Case Library (TCL);
Part 5: Abstract Test Suite (ATS) - Data Link Control (DLC) layer**

ETSI

European Telecommunications Standards Institute

ETSI Secretariat

Postal address: F-06921 Sophia Antipolis CEDEX - FRANCE

Office address: 650 Route des Lucioles - Sophia Antipolis - Valbonne - FRANCE

X.400: c=fr, a=atlas, p=etsi, s=secretariat - **Internet:** secretariat@etsi.fr

Tel.: +33 4 92 94 42 00 - Fax: +33 4 93 65 47 16

Copyright Notification: No part may be reproduced except as authorized by written permission. The copyright and the foregoing restriction extend to reproduction in all media.

© European Telecommunications Standards Institute 1997. All rights reserved.

Contents

Foreword	5
1 Scope	7
2 Normative references	7
3 Definitions and abbreviations	9
3.1 Definitions	9
3.2 Abbreviations	11
4 Abstract Test Method (ATM)	12
5 Untestable Test Purposes (TP)	13
6 ATS Conventions	13
6.1 Naming conventions	13
6.1.1 Declarations part	13
6.1.1.1 Test suite type and structured type definitions	13
6.1.1.2 Test suite operations definitions	13
6.1.1.3 Test suite parameter declarations	14
6.1.1.4 Test case selection expression definitions	14
6.1.1.5 Test suite constant declarations	14
6.1.1.6 Test suite variable declarations	14
6.1.1.7 Test case variable declarations	14
6.1.1.8 PCO declarations	14
6.1.1.9 Timer declarations	15
6.1.1.10 ASP type definitions	15
6.1.1.11 PDU type definitions	15
6.1.1.12 Alias definitions	15
6.1.2 Constraints part	16
6.1.3 Dynamic part	16
6.1.3.1 Test Case identifier	16
6.1.3.2 Test step identifier	16
6.1.3.3 Default identifier	16
6.1.3.4 General aspects	17
6.1.3.5 ATS abbreviations	17
6.2 Implementation conventions	17
6.2.1 Declaration part	17
6.2.2 Constraint part	18
6.2.3 Dynamic part	18
6.2.4 Documentation	19
7 Test case and test purpose mapping	19
Annex A (normative): ATS for DECT DLC	20
A.1 The machine processable ATS (TTCN.MP)	20
A.2 The graphical ATS (TTCN.GR)	20
Annex B (normative): Partial PIXIT proforma for DECT DLC	21
B.1 Identification summary	21
B.2 ATS summary	21

B.3	Test laboratory.....	21
B.4	Client identification.....	21
B.5	SUT.....	22
B.6	Protocol layer information.....	22
B.6.1	Protocol identification.....	22
B.6.2	IUT information.....	22
B.6.2.1	General configuration.....	22
B.6.2.2	Parameter values.....	22
B.6.2.3	Timer values.....	23
B.6.2.4	Network parameter values.....	23
B.6.3	Procedural Information.....	24
B.6.3.1	Class U procedural information.....	24
B.6.3.2	Class A procedural information.....	25
B.6.3.3	Paging procedural information.....	26
B.6.3.4	Class 0 procedural information.....	27
B.6.3.5	Class 1 procedural information.....	27
Annex C (normative):	Protocol Conformance Test Report (PCTR) Proforma for DECT DLC.....	28
C.1	Identification summary.....	28
C.1.1	Protocol conformance test report.....	28
C.1.2	IUT identification.....	28
C.1.3	Testing environment.....	28
C.1.4	Limits and reservation.....	29
C.1.5	Comments.....	29
C.2	IUT Conformance status.....	29
C.3	Static conformance summary.....	29
C.4	Dynamic conformance summary.....	29
C.5	Static conformance review report.....	30
C.6	Test campaign report.....	31
C.7	Observations.....	32
Annex D (informative):	Bibliography.....	33
History.....		34

Foreword

This draft second edition European Telecommunication Standard (ETS) has been produced by the Digital Enhanced Cordless Telecommunications (DECT) Project of the European Telecommunications Standards Institute (ETSI), and is now submitted for the Public Enquiry phase of the ETSI standards approval procedure.

This ETS comprises nine parts, as follows:

- Part 1: "Test Suite Structure (TSS) and Test Purposes (TP) for Medium Access Control (MAC) layer".
- Part 2: "Abstract Test Suite (ATS) for Medium Access Control (MAC) layer - Portable radio Termination (PT)".
- Part 3: "Abstract Test Suite (ATS) for Medium Access Control (MAC) layer - Fixed radio Termination (FT)".
- Part 4: "Test Suite Structure (TSS) and Test Purposes (TP) - Data Link Control (DLC) layer".
- Part 5: "Abstract Test Suite (ATS) - Data Link Control (DLC) layer".**
- Part 6: "Test Suite Structure (TSS) and Test Purposes (TP) - Network (NWK) layer - Portable radio Termination (PT)".
- Part 7: "Abstract Test Suite (ATS) for Network (NWK) layer - Portable radio Termination (PT)".
- Part 8: "Test Suite Structure (TSS) and Test Purposes (TP) - Network (NWK) layer - Fixed radio Termination (FT)".
- Part 9: "Abstract Test Suite (ATS) for Network (NWK) layer - Fixed radio Termination (FT)".

Proposed transposition dates	
Date of latest announcement of this ETS (doa):	3 months after ETSI publication
Date of latest publication of new National Standard or endorsement of this ETS (dop/e):	6 months after doa
Date of withdrawal of any conflicting National Standard (dow):	6 months after doa

Blank page

1 Scope

This European Telecommunication Standard (ETS) contains the Abstract Test Suite (ATS) to test the Digital Enhanced Cordless Telecommunications (DECT) Data Link Control (DLC) layer.

The objective of this test specification is to provide a basis for approval tests for DECT equipment giving a high probability of air interface inter-operability between different manufacturer's DECT equipment.

The ISO standard for the methodology of conformance testing (ISO/IEC 9646-1 [10], ISO/IEC 9646-2 [11], ISO/IEC 9646-3 [12] and ISO/IEC 9646-5 [14]) as well as the ETSI rules for conformance testing (ETS 300 406 [9] and ETR 141 [22]) are used as basis for the test methodology.

Test specifications for the Physical Layer (PHL), Medium Access Control (MAC) layer, and Network (NWK) layer are provided in other the DECT standards.

Annex A provides the Tree and Tabular Combined Notation (TTCN) part of this ATS.

Annex B provides the Partial Protocol Implementation Extra Information for Testing (PIXIT) Proforma of this ATS.

Annex C provides the Protocol Conformance Test Report (PCTR) Proforma of this ATS.

2 Normative references

This ETS incorporates, by dated or undated reference, provisions from other publications. These normative references are cited at the appropriate places in the text and the publications are listed hereafter. For dated references, subsequent amendments to or revisions of any of these publications apply to this ETS only when incorporated in it by amendment or revision. For undated references the latest edition of the publication referred to applies.

- [1] ETS 300 175-1: "Radio Equipment and Systems (RES); Digital European Cordless Telecommunications (DECT); Common Interface (CI); Part 1: Overview".
- [2] ETS 300 175-2: "Radio Equipment and Systems (RES); Digital Enhanced Cordless Telecommunications (DECT); Common Interface (CI); Part 2: Physical layer (PHL)".
- [3] ETS 300 175-3: "Radio Equipment and Systems (RES); Digital European Cordless Telecommunications (DECT); Common Interface (CI); Part 3: Medium Access Control (MAC) layer".
- [4] ETS 300 175-4: "Radio Equipment and Systems (RES); Digital European Cordless Telecommunications (DECT); Common Interface (CI); Part 4: Data Link Control (DLC) layer".
- [5] ETS 300 175-5: "Radio Equipment and Systems (RES); Digital European Cordless Telecommunications (DECT); Common Interface (CI); Part 5: Network (NWK) layer".
- [6] ETS 300 175-6: "Radio Equipment and Systems (RES); Digital European Cordless Telecommunications (DECT); Common Interface (CI); Part 6: Identities and addressing".
- [7] ETS 300 175-7: "Radio Equipment and Systems (RES); Digital European Cordless Telecommunications (DECT); Common Interface (CI); Part 7: Security features".
- [8] ETS 300 175-8: "Radio Equipment and Systems (RES); Digital European Cordless Telecommunications (DECT); Common Interface (CI); Part 8: Speech coding and transmission".

- [9] ETS 300 406: "Methods for Testing and Specification (MTS); Protocol and profile conformance testing specifications; Standardization methodology".
- [10] ISO/IEC 9646-1 (1991): "Information technology - Open Systems Interconnection - Conformance testing methodology and framework - Part 1: General concepts". (See also CCITT Recommendation X.290 (1991)).
- [11] ISO/IEC 9646-2 (1991): "Information technology - Open Systems Interconnection - Conformance testing methodology and framework - Part 2: Abstract test suite specification". (See also CCITT Recommendation X.291 (1991)).
- [12] ISO/IEC 9646-3 (1991): "Information technology - Open Systems Interconnection - Conformance testing methodology and framework - Part 3: The tree and tabular combined notation". (See also CCITT Recommendation X.292 (1992)).
- [13] ISO/IEC 9646-4 (1991): "Information technology - Open Systems Interconnection - Conformance testing methodology and framework - Part 4: Test realisation". (See also CCITT Recommendation X.292 (1992)).
- [14] ISO/IEC 9646-5 (1991): "Information technology - Open Systems Interconnection - Conformance testing methodology and framework - Part 5: Requirements on test laboratories and clients for the conformance assessment process". (See also CCITT Recommendation X.292 (1992)).
- [15] ISO/IEC 9646-6 (1991): "Information technology - Open Systems Interconnection - Conformance testing methodology and framework - Part 6: Protocol profile test specification".
- [16] ISO/IEC 9646-7 (1991): "Information technology - Open Systems Interconnection - Conformance testing methodology and framework - Part 7: Implementation conformance statement".
- [17] ISO 7498: "Information Processing Systems - Open Systems Interconnection - Basic Reference model".
- [18] 91/263/EEC: "Council Directive of 29 April 1991 on the approximation of the laws of the Member States concerning telecommunications terminal equipment, including the mutual recognition of their conformity" (Terminal Directive).
- [19] TBR 6: "Radio Equipment and Systems (RES); Digital Enhanced Cordless Telecommunications (DECT); General terminal attachment requirements".
- [20] TBR 10: "Radio Equipment and Systems (RES); Digital Enhanced Cordless Telecommunications (DECT); General terminal attachment requirements; Telephony applications".
- [21] TBR 22: "Radio Equipment and Systems (RES); Attachment requirements for terminal equipment for Digital Enhanced Cordless Telecommunications (DECT) Generic Access Profile (GAP) applications".
- [22] ETR 141: "Methods for Testing and Specification (MTS); Protocol and profile conformance testing specifications; The Tree and Tabular Combined Notation (TTCN) style guide".

3 Definitions and abbreviations

3.1 Definitions

For the purposes of this ETS, the following definitions apply:

Abstract Test Suite (ATS): See ISO/IEC 9646-1 [10];

C-Plane: The Control Plane of the DECT protocol stacks, which contains all of the internal DECT protocol control, but may also include some external user information.

NOTE 1: The C-Plane stack always contains protocol entities up to and including the network layer.

DLC data link (DLC link): An association between two DLC layer entities. This can either be one C-Plane association or one User Plane (U-Plane) association.

NOTE 2: This is not the same as a MAC connection.

DLC Frame: The format used to structure all messages that are exchanged between DLC layer peer entities.

NOTE 3: Different DLC frames are used in the C-Plane and the U-Plane, and there is more than one format of DLC frame in each plane.

Fixed radio Termination (FT): A logical group of functions that contains all of the DECT processes and procedures on the fixed side of the DECT air interface.

NOTE 4: A FT only includes elements that are defined in the ETS 300 175 [1] to [8]. This includes radio transmission elements (layer 1) together with a selection of layer 2 and layer 3 elements.

flow control: The mechanism that is used to regulate the flow of data between two peer entities.

fragment: One of the service data units that is produced by the process of fragmentation.

NOTE 5: This is not the same as a segment.

fragmentation: The process of dividing a protocol data unit into more than one service data unit for delivery to a lower layer. The reverse process is recombination.

NOTE 6: This is not the same as segmentation.

Implementation Under Test (IUT): See ISO/IEC 9646-1 [10];

Lower Layer Management Entity (LLME): A management entity that spans a number of lower layers, and is used to describe all control activities which do not follow the rules of layering.

NOTE 7: The DECT LLME spans the network layer, the DLC layer, the MAC layer and the physical layer.

Lower Tester (LT): See ISO/IEC 9646-1 [10];

Network (NWK) layer: See ISO 7498 [17];

PCTR proforma: See ISO/IEC 9646-5 [14];

Physical Layer (PHL): See ISO 7498 [17].

Point of Control and Observation (PCO): See ISO/IEC 9646-1 [10];

Portable radio Termination (PT): A logical group of functions that contains all of the DECT processes and procedures on the portable side of the DECT air interface.

NOTE 8: A PT only includes elements that are defined in ETS 300 175 [1] to [8]. This includes radio transmission elements (layer 1) together with a selection of layer 2 and layer 3 elements.

Protocol Conformance Test Report (PCTR): See ISO/IEC 9646-5 [14];

Protocol Implementation Conformance Statement (PICS): See ISO/IEC 9646-1 [10];

PICS proforma: See ISO/IEC 9646-1 [10];

Protocol Implementation Extra Information for Testing (PIXIT): See ISO/IEC 9646-1 [10];

PIXIT proforma: See ISO/IEC 9646-1 [10];

segment: One of the pieces of data that is produced by the process of segmentation.

NOTE 9: In general, one segment only represents a portion of a complete message.

segmentation: The process of partitioning one service data unit from a higher layer into more than one protocol data unit. The reverse process is assembly.

sequencing (sequence numbering): The process of adding a sequence number to a set of data packets so that the packets can be reassembled in the correct order, regardless of the order in which they are received. See also segmentation.

System Under Test (SUT): See ISO/IEC 9646-1 [10];

U-Plane: The user plane of the DECT protocol stacks. This plane contains most of the end-to-end (external) user information and user control.

NOTE 10: The U-Plane protocols do not include any internal DECT protocol control, and it may be null at the network layer and at the DLC layers for some services.

Upper Tester (UT): See ISO/IEC 9646-1 [10];

3.2 Abbreviations

For the purposes of this ETS, the following abbreviations apply:

ASP	Abstract Service Primitive
BI	Invalid Behaviour
BO	Inopportune Behaviour
BV	Valid Behaviour
C/L	Connectionless mode. See definitions
C/O	Connection Oriented mode. See definitions
CA	Capability tests
C-Plane	Control Plane. See definitions
DECT	Digital Enhanced Cordless Telecommunications
DLC	Data Link Control
FP	Fixed Part
FT	Fixed radio Termination
IUT	Implementation Under Test
LLME	Lower Layer Management Entity
LT	Lower Tester
MAC	Medium Access Control
MSAP	MAC Service Access Point
NWK	Network
PCO	Point of Control and Observation
PDU	Protocol Data Unit
PHL	Physical Layer
PICS	Protocol Implementation Conformance Statements
PIXIT	Protocol Implementation Extra Information for Testing
PMID	Portable Part MAC Identity
PP	Portable Part
PT	Portable radio Termination
SAP	Service Access Point
SUT	System Under Test
TC	Test Case
TDMA	Time Division Multiple Access
TP	Test Purposes
U-Plane	User Plane
USAP	Upper Service Access Point
UT	Upper Tester

4 Abstract Test Method (ATM)

This clause describes the ATM used for testing the DECT DLC protocol. It is the embedded variant of Remote Single (RSE) layer test method. The RSE test method has been selected, because:

- this test method implies no specific requirements from the IUT;
- the Upper Service Access Point (USAP) of the IUT cannot be directly observed;
- the variety of the possible DECT implementations is a serious technical obstacle for the adoption of a different ATM;
- this test method places the minimum limitations in the realisation of conformance testing.

The embedded variant of the remote test method provides sufficient control of the IUT DLC behaviour, through NWK layer messages conveyed by DLC frames.

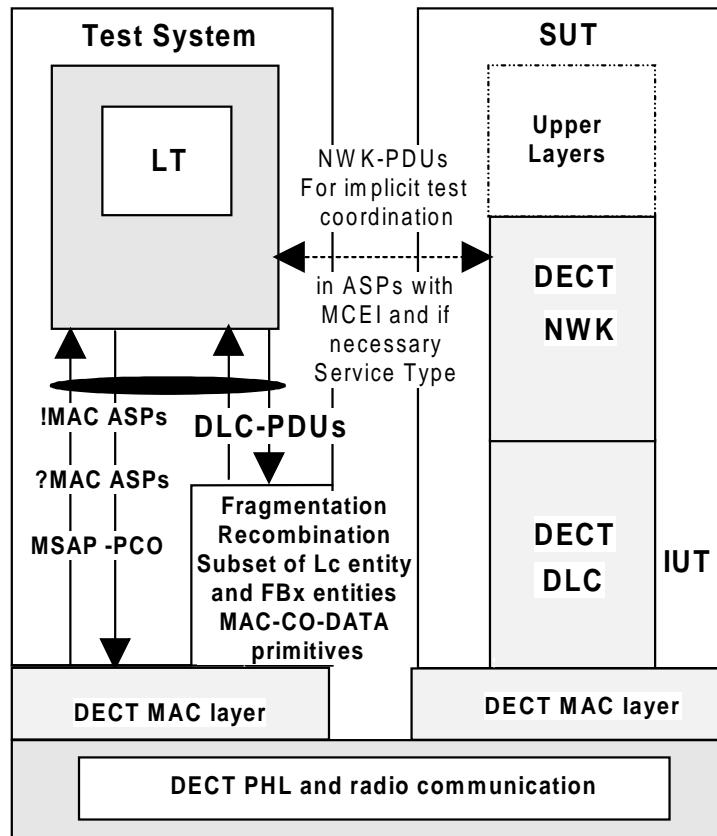

Figure 1: RS test Method embedded variant

LT A Lower Tester (LT) is located in a remote DECT test system. It controls and observes the behaviour of the IUT.

MSAP MAC Service Access Point - A unique MAC SAP is defined at the DECT interface and used to exchange service data of the DLC protocol. To avoid the complexity of data fragmentation and recombination testing, the SAP is defined below this functions of the DLC layer.

PCO The PCO for DLC layer testing is located on the MSAP. All test events at the PCO are specified in terms of MAC Abstract Service Primitives (ASPs) and DLC layer Protocol Data Units (PDUs).

Notional UT No explicit upper tester (UT) exists in the system under test. Nevertheless, some network messages are sent to the SUT for the need of the co-ordination procedures. The network layer of the SUT is used as a notional UT as defined in ISO 9646.

The MSAP primitives are defined according to ETS 300 175-3 [3] clause 8 and associated subclauses.

5 Untestable Test Purposes (TP)

Due to the ATMs chosen for this ATS or other restrictions, the test purposes in table 1 have been identified as being in the untestable category, and therefore have not been derived into final test case:

Table 1: Untestable TP

Test purpose	Reason
TPUV_000	No procedure can be defined to determine if, after receiving the first UI frame, the IUT considers the class U link as established. It is an internal state of the DLC layer of the IUT.
TPUV_001	No procedure can be defined to determine if, after receiving an upward release, the IUT considers the class U link as released. It is an internal state of the DLC layer of the IUT.
TPAV_009	Test for connection handover needs some clarification and agreement from the respective RES03 subgroup before that are written.
TPAV_010	Test for connection handover needs some clarification and agreement from the respective RES03 subgroup before that are written.
TPLC_002	Prioritised queuing of broadcast message between normal and expedited data is not testable. It is very difficult to define a procedure in the IUT to force it, to transmit normal and expedited data in a sufficient short time. It is, also, very difficult for the tester to transmit normal and expedited data in sufficient short time and to define a procedure to verify the correct order of the reception in the IUT.

6 ATS Conventions

This clause describes the conventions applied to define the ATS and gives the naming conventions chosen for the different elements of the ATS.

The ATS conventions are intended to give a better understanding of the ATS but they describe also the conventions made for the development of the ATS, thus for any later maintenance purposes or further development of the ATS the conventions described in this clause shall be considered.

The ATS conventions contain two subclauses, the naming conventions and the implementation conventions. The naming conventions describe the structure of the naming of all ATS elements. The implementation conventions describe the functional structure of the ATS.

6.1 Naming conventions

6.1.1 Declarations part

This subclause describes the naming conventions chosen for the elements of the ATS declarations part.

6.1.1.1 Test suite type and structured type definitions

The test suite type and test suite structured type identifiers describe the information elements, and are written in uppercase:

EXAMPLE: PROTOCOL_DISCRIMINATOR simple type.
 FILLSTRING structured type

6.1.1.2 Test suite operations definitions

The test suite operation identifiers are composed of string in lowercase letters starting by the uppercase string "TSO_".

EXAMPLE: TSO_compute_checksum.

6.1.1.3 Test suite parameter declarations

The test suite parameter identifiers are composed of string in lowercase letters starting by the uppercase string "TSP_".

EXAMPLE: TSP_window_size.

If the test suite parameter references a PICS item, the letter "C" is added to the standard prefix.

EXAMPLE: TSPC_pics_item_s23.

If the test suite parameter references a PIXIT item, the letter "X" is added to the standard prefix.

EXAMPLE: TSPX_pixit_item_2.

Complete names as defined in the specifications are used.

6.1.1.4 Test case selection expression definitions

The naming conventions for the test case selection expression definitions use free text starting with an uppercase letter. The name of the expression shall explain clearly the selection rule. The test case selection expressions are logical combinations of the test suite parameters definitions.

Certain test cases are selected only when the IUT is a FT part or a PT part. Therefore, to cover all test cases applicable to the implementation, it is necessary to change the relevant test suite parameter for running the desired test cases.

6.1.1.5 Test suite constant declarations

The test suite constant identifiers are composed of string in lowercase letters starting by the uppercase string "TSC_".

EXAMPLE: TSC_retry.

Complete names as defined in the specifications are used.

6.1.1.6 Test suite variable declarations

The test suite variable identifiers are composed of string in lowercase letters starting by the uppercase string "TSV_".

EXAMPLE: TSV_count.

Exception: If the test suite variable represents a system parameter or value, the name defined in the specifications is used.

EXAMPLE: VR,VS.

6.1.1.7 Test case variable declarations

The test case variable identifiers are composed of string in lowercase letters starting by the uppercase string "TCV_".

EXAMPLE: TCV_cr_value.

6.1.1.8 PCO declarations

The point of control and observation identifiers are composed of two or four capital letters, beginning with "L", as there are only LTs.

EXAMPLE: LMAC represents a PCO on MAC interface as LT in the test equipment.
LDLC represents a PCO on DLC interface as LT in the test equipment.

6.1.1.9 Timer declarations

Two kinds of timers can be distinguished:

1) **standardised:**

Those defined in the standard, e.g. DL_04, use exactly the same name as in the standard, beginning with a capital "T".

As there is a tolerance margin accepted for these timers, three values are needed:

- the maximum value allowed, which will use the suffix "_max";
- the minimum value allowed, which will use the suffix "_min";
- the value actually implemented, with no suffix.

EXAMPLE 1: TDL_04_max, TDL_04_min, and TDL_04.

2) **not standardised:**

Those not defined in the standard, i.e. for execution use, e. g. a timer waiting for a response. These timers begin with the prefix "T_", followed by a string in lowercase letters.

EXAMPLE 2: T_resp represents a timer for controlling the response time of the IUT.

6.1.1.10 ASP type definitions

The identifier of an ASP uses exactly the nearest name as the name defined in the specifications. It is written in uppercases, finishing by an underscore character ("_"), and three capital letters indicating whether it is a request, an indication, a response or a confirmation primitive.

EXAMPLE: DL_RELEASE_REQ for an ASP containing a layer 3 release request passed to layer 2;
MAC_DATA_REQ for an ASP containing a layer 2b PDU passed to layer 2a.

6.1.1.11 PDU type definitions

The identifier of a PDU is given in a string in uppercase letters, which represents the layer message.

EXAMPLE 1: RR for the Receive Ready layer 2 message;
DISCONNECT for the DISCONNECT layer 3 message.

Where the message is a composite word, an underscore character ("_") appears in the string.

EXAMPLE 2: RELEASE_COMPLETE is the RELEASE COMPLETE layer 3 message.

6.1.1.12 Alias definitions

These are used to make the sending and receiving of PDUs within ASPs more understandable when writing the dynamic part of the test suite. This is done by giving the ASP an alias. The alias name indicates the PDU carried by the ASP and whether it is sent or received by the tester.

No alias are used in the test suite.

6.1.2 Constraints part

This subclause describes the naming conventions chosen for the elements of the ATS constraints part.

Constraint identifiers commence with uppercase. The remaining part of the Id name is written in lowercase.

Identifier names of elements concerning the same subject have equivalent names in the declaration and the constraint part:

- Declaration Part: CC_SETUP;
- Constraint Part: Cc_setup.

The name of the modified constraint describes the particularity of the modified constraint:

EXAMPLE: Cc_setup_mand_only (modified Cc_setup with only the mandatory Information Elements).

If formal parameter lists are used, the variable names are written in lowercase. The variable name is the same as the name of the element it is representing.

6.1.3 Dynamic part

This subclause describes the naming conventions chosen for the elements of the ATS dynamic part.

6.1.3.1 Test Case identifier

The identifier of a test case is built according to table 2:

Table 2: Test Case (TC) naming convention

Identifier:	TC-<fm>-x-<nnn>		
	<fm>	= functional module	U Control plane Class U services A Control plane Class A services B Control plane Class B services L Control plane Broadcast services 0 User plane transmission Class 0 1 User plane transmission Class 1 2 User plane transmission Class 2 3 User plane transmission Class 3
	x	= Type of testing	CA CA, Capability tests BV BV, Valid Behaviour tests BO BO, Inopportune Behaviour tests BI BI, Invalid Behaviour tests
	<nnn>	= sequential number	(000-999) test case Number

6.1.3.2 Test step identifier

The test step identifier is built with a string of lowercase letters led by a string of capital letter and joined by an underscore character. The first string indicates the main function of the test step; e.g. PR for preamble, PO for postamble, LTS for local tree name and STP for general step. The second string indicates the meaning of the step.

EXAMPLES: PR_name;
 PO_name;
 LTS_name;
 STP_name.

6.1.3.3 Default identifier

The Default identifiers begin with the prefix "DF_", followed by a string in lowercase letters.

6.1.3.4 General aspects

All verdict assignments are labelled. To allow an exact identification in which table the verdict was assigned, the following name convention is applied:

TB	test Body;
DF	Default;
EH	Error handling test steps;
PO	POstamble;
PR	PReamble;
TS	test step.

6.1.3.5 ATS abbreviations

These abbreviations are used to shorten identifier names:

addr	address
ack	acknowledgement
cau	cause
cc	call control
chn	channel
est	establish
ind	indication
mety	message type
mod	modified
par	parameter
pd	protocol discriminator
req	request
rsp	response

6.2 Implementation conventions

6.2.1 Declaration part

The comment line of single element TTCN tables (e.g. test suite constants) is used to give a reference where the format and content of the element is described in the relevant protocol specifications. Any particularity of the element format or content is described in the comment line.

The comment line in the header of multi element TTCN tables (e.g. ASPs) is used to reference to the protocol specification.

The detailed comments are used to describe any particularity of the table.

In the ASP and PDU declarations, the comments column is used to identify if an element is mandatory or optional:

- M: mandatory;
- O: optional.

In the ASP and PDU declarations the comments column is further used to give information about the element value, in particular if the element contains a fixed spare value.

6.2.2 Constraint part

The ASPs and PDUs are defined in a way that all relevant elements are parametrized. That improves the transparency of the constraints in the dynamic part, as all values which are relevant for the test are always present.

Generally no modified constraints are used, this allows an easier reuse and adaptation of constraints if they are reused in other DECT profile test specifications.

The comment line of a constraint contains always the reference to the used specifications.

The detailed comments sector is used to describe any particularity of the table.

6.2.3 Dynamic part

Some TCs need a particular initialisation of the IUT environment conditions to run the actual test, e.g. for testing re-provisioning procedures. Such message sequence can be quite complicated and long. In cases where a local test step (LTS) facilitates the TC structure, the preamble and the condition setting are described in a LTS called LTS_pre_step. All LTS_pre_steps are described in the detailed comment part of the TTCN table.

Some TCs need after the actual test a particular re-initialization of the IUT, e.g. after re-provisioning. Such message sequence can be quite complicated and long. In cases where a local test step (LTS) facilitates the TC structure, the postamble and the re-initialization are described in a LTS called LTS_post_step. All LTS_post_steps are described in the detailed comment part of the TTCN table.

All events which are defined as a conformance requirements by the TP, cause a preliminary verdict PASS if the requirement is met.

All invalid events are handled in the default tree. Only FAIL verdicts can be assigned in the default tree.

The preamble, the test body and the postamble have different defaults, which allows a specific verdict handling, e.g. only INCONC verdicts are assigned in the preamble.

Test steps do not contain a default. That allows to apply them with no restrictions regarding the error handling.

All verdict assignments are labelled. According to ISO 9646-3 [12], annex E.2, labels should be written to the conformance log. This allows to identify where the test failed. To allow an exact identification in which table the verdict was assigned, the naming convention as described in subclause 6.1.3.4 is applied.

The labels of the same type are numbered sequentially if they are in the same TC, test step or default.

TP which are listed in the untestable TP list, or which reference to an other TP, e.g. BV TP which were already defined as CA TP, are not considered in the ATS, thus these TC identifiers are missing in the ATS and the numbering of the TCs is not always continuous.

6.2.4 Documentation

The comment line of the TC or test step header contains a reference to the relevant protocol specification.

The comment column of the dynamic behaviour part is used to number the test events which are relevant for the particular test or test operation.

Based on the numbering in the comment column all for the TC relevant events are described in the detailed comments part of each TTCN table.

Test procedures which cover a conformance requirement and lead to a preliminary or final verdict assignment are described as follows in the detailed comments part:

- Expected event: a specific receive event is expected;
- Expected behaviour: no event or a timer expiry is expected;
- Expected status: the IUT is expected to be in a particular status.

7 Test case and test purpose mapping

There is a one-to-one mapping between the test case identifiers and the test purpose identifiers. The correspondence rule is given by the following examples:

Test purpose identifier	Test case identifier
TPUV-001	TC-U-BV-001
TPAI-011	TC-A-BI-011
TPBO-028	TC-B-BO-028
TPBV-034	TC-B-BV-034
TP2C-000	TC-2-CA-000

Annex A (normative): ATS for DECT DLC

The ATS is written in TTCN according to ISO/IEC 9646-3 [12].

As the ATS was developed on a separate TTCN tool the TTCN tables are not completely referenced in the contents table. The ATS itself contains a subclause test suite Overview which provides additional information and references about the ATS.

NOTE: According to ISO/IEC 9646-3 [12], in case of a conflict in interpretation of the operational semantics of TTCN.GR and TTCN.MP, the operational semantics of the TTCN.GR representation takes precedence.

A.1 The machine processable ATS (TTCN.MP)

The electronic form of the machine processable file (TTCN MP format) corresponding to this ATS is contained in an ASCII text file (DEP04975.MP (note)) associated with this ETS.

NOTE: This file is located in a compressed archive file named 4975_EP.LZH. Other file formats are available on request.

A.2 The graphical ATS (TTCN.GR)

The electronic form of the graphical ATS (TTCN GR format) corresponding to this ATS is contained in an ASCII Postscript file (DEP04975.PS (note)) associated with this ETS.

NOTE: This file is located in a compressed archive file named 4975_EP.LZH. Other file formats are available on request.

Annex B (normative): Partial PIXIT proforma for DECT DLC

Notwithstanding the provisions of the copyright clause related to the text of this ETS, ETSI grants that users of this ETS may freely reproduce the PIXIT proforma in this annex so that it can be used for its intended purposes and may further publish the completed PIXIT.

The PIXIT Proforma is based on ISO/IEC 9646-6 [15]. Any additional information needed can be found in this international standard document.

B.1 Identification summary

Table B.1

PIXIT Number:	
Test Laboratory Name:	
Date of Issue:	
Issued to:	

B.2 ATS summary

Table B.2

Protocol Specification:	ETS 300 175-4
Protocol to be tested:	
ATS Specification:	ETS 300 497-5
Abstract Test Method:	Remote, embedded variant

B.3 Test laboratory

Table B.3

Test Laboratory Identification:	
Test Laboratory Manager:	
Means of Testing:	
Service Access Point (SAP) Address:	

B.4 Client identification

Table B.4

Client Identification:	
Client Test manager:	
Test Facilities required:	

B.5 SUT

Table B.5

Name:	
Version:	
SCS Number:	
Machine configuration:	
Operating System Identification:	
IUT Identification:	
PICS Reference for IUT:	
Limitations of the SUT:	
Environmental Conditions:	

B.6 Protocol layer information

B.6.1 Protocol identification

Table B.6

Name:	DECT - Data Link Control Layer - ETS 300 175-4
Version:	
PICS References:	

B.6.2 IUT information

B.6.2.1 General configuration

Table B.7 General configuration

Item	Parameter	Parameter Type	Explanation	Value
1	TSPX_pt	BOOLEAN	Indicate the IUT type (PT = TRUE - FT = FALSE)	
2	TSPX_chn	BOOLEAN	Indicate the desired signalling channel for testing signalling procedure (For I _N or I _P testing only C _S channel is used). For C _S write FALSE and write TRUE for C _F	
3	TSPX_slot	SLOT_TYPE	Indicate the slot type to be use in MAC connection for the test suite (Half = 0 - Full = 1 - Double = 2)	

B.6.2.2 Parameter values

Table B.8 Parameter values

Item	Parameter	Parameter Type	Explanation	Value
1	TSPX_n250	INTEGER	Indicate the value of the re-transmission counter for Class A establishment procedure.	
2	TSPX_k1	INTEGER	If supported, indicate the value of Class 1 sending window.	
3	TSPX_rpn	RPN	FT's Radio fixed Part Number	
4	TSPX_rpn1	RPN	Second FT's Radio fixed Part Number for Intercell Handover	

B.6.2.3 Timer values

Table B.9 Timer values

Item	Parameter	Parameter Type	Type	Value
1	TSPX_dl04_value	INTEGER	Indicate the value of the Class A established state re-transmission timer	
2	TSPX_dl07_value	INTEGER	Indicate the value of the Class A establishment timer	
3	TSPX_dlu01_value	INTEGER	Indicate the of the Class 1 timer	

B.6.2.4 Network parameter values

Table B.10 Network parameter values

Item	Parameter	Parameter Type	Explanation	Value
1	TSPX_ari	ARI	Access Rights Identity	
2	TSPX_pmid	PMID	Portable MAC Identity	
3	TSPX_fid	FIXED_IDENTITY	Fixed Identity	
4	TSPX_pid	PORTABLE_IDENTITY	Portable Identity	
5	TSPX_cipher_info	CIPHER_INFO	NWK cipher information	
6	TSPX_nwk_assigned_id	NWK_ASGN_IDENTITY	NWK assigned Identity	
7	TSPX_ipui_class	IPUI-CLASS	Class of international portable user identity	
8	TSPX_ipui	BITSTRING	International Portable User Identity	

B.6.3 Procedural Information

B.6.3.1 Class U procedural information

Table B.11 Class U reception procedural information

Item	Parameter	Parameter Type	Explanation	Value
1	TSPX_cu_receive_on_co	BOOLEAN	In case of an open Mac connection exist, the IUT is able to receive Class U information frame (UI frame) in this connection?	TRUE FALSE
2	TSPX_cu_rec_proc_defined	BOOLEAN	Is it possible to determine if the IUT received a Class U information frame (UI frame)?	TRUE FALSE
3	TPSPX_ui_pdu_on_co	BITSTRING	If item 1 and item 2 are TRUE: Indicate in the following lines the desired information field for the UI frame.	
	TSO_iut_ui_received	Test suite Operation	If item 1 and item 2 are TRUE: Indicate in the following lines the procedure to determine the reception of the UI frame.	
4	TPSPX_ui_pdu_on_cl	BITSTRING	If item 1 is FALSE and item 2 is TRUE: Indicate in the following lines the desired information field for the UI frame.	
	TSO_iut_ui_received	Test suite Operation	If item 1 is FALSE and item 2 is TRUE: Indicate in the following lines the procedure to determine the reception of the UI frame.	

Table B.12 Class U transmission procedural information

Item	Parameter	Parameter Type	Explanation	Value
1	TSPX_cu_snd_proc_defined	BOOLEAN	Is it possible to force the IUT to transmit a Class U information frame (UI frame)?	TRUE FALSE
	STP_invoke_uplink_data for PT part STP_invoke_downlink_data for FT part	Implicit Send	If item 1 is TRUE: Indicate in the following lines the procedure to transmit the UI frame.	
2	TSPX_cu_transmit_on_co	BOOLEAN	In case of an open Mac connection exist, the IUT uses this connection for transmitting Class U information frame (UI frame)?	TRUE FALSE
	STP_invoke_class_data_on_co	Implicit Send	If item 1 and item 2 are TRUE: Indicate in the following lines the procedure to transmit the UI frame.	

B.6.3.2 Class A procedural information

Table B.13 Class A procedural information

Item	Parameter	Parameter Type	Explanation	Value
1	TSPX_ca_accept_est	BOOLEAN	Does the IUT react properly in case of reception of the Class A establishment request?	TRUE FALSE
2	TSPX_ca_re_establish_invoke	BOOLEAN	Only if the IUT is a Portable Part (PP): Is it possible to force the IUT to initiate Class A link re-establishment?	TRUE FALSE
	STP_invoke_class_re_establishment	Implicit Send	If item 2 is TRUE: Indicate in the following lines the procedure to force the IUT to re-establish the Class A link.	
3	TSPX_ca_initiate_est	BOOLEAN	Is the IUT able to initiate Class A link establishment?	TRUE FALSE

B.6.3.3 Paging procedural information

Table B.14 Paging procedural information

Item	Parameter	Parameter Type	Explanation	Value
1	TSPX_lbs_proc_defined	BOOLEAN	Only if the IUT is a Fixed Part (FP): Is it possible to force if the IUT to transmit a LCE-PAGE-REQUEST message in short format (3 octets)?	TRUE FALSE
	STP_invoke_short_page	Implicit Send	If item 1 is TRUE: Indicate in the following lines the procedure to force the transmission of the LCE-PAGE-REQUEST message in short format.	
2	TSPX_lbl_proc_defined	BOOLEAN	Only if the IUT is a FP: Is it possible to force if the IUT to transmit a LCE-PAGE-REQUEST message in long format (5 octets)?	TRUE FALSE
	STP_invoke_long_page	Implicit Send	If item 2 is TRUE: Indicate in the following lines the procedure to force the transmission of the LCE-PAGE-REQUEST message in long format.	

B.6.3.4 Class 0 procedural information

Table B.15 Class 0 procedural information

Item	Parameter	Parameter Type	Explanation	Value
1	TSPX_in_rec_proc_defined	BOOLEAN	Is it possible to determine if the IUT received a Class 0 FU1 IN frame?	TRUE FALSE
2	TSPX_in_pdu	OCTETSTRING	If item 1 is TRUE: Indicate in the following lines the desired information field for the FU1 frame.	
	TSPX_iut_in_received	Test suite Operation	If item 1 is TRUE: Indicate in the following lines the procedure to determine the reception of the FU1 frame.	
3	TSPX_fu1_snd_proc_defined	BOOLEAN	Is it possible to force the IUT to transmit a Class 0 FU1 frame?	TRUE FALSE
	STP_invoke_fu1_frame	Implicit Send	If item 3 is TRUE: Indicate in the following lines the procedure to force the IUT to transmit the FU1 frame.	

B.6.3.5 Class 1 procedural information

Table B.16 Class 1 procedural information

Item	Parameter	Parameter Type	Explanation	Value
1	TSPX_uln	ULN	Indicate the value of the U plane link number (ULN) used on the first IP service for FU5 frame.	
2	TSPX_irc1_value	INTEGER	Indicate the duration (in seconds) of the buffering period of out of sequence frame(s). (L(R) Time Division Multiple Access (TDMA) frames).	
3	TSPX_fu5_snd_proc_defined	BOOLEAN	Is it possible to force the IUT to transmit a Class 1 FU5 frame?	TRUE FALSE
	STP_invoke_fu5_frame	Implicit Send	If item 3 is TRUE: Indicate in the following lines the procedure to force the IUT to transmit the FU5 frame.	

Annex C (normative): Protocol Conformance Test Report (PCTR) Proforma for DECT DLC

Notwithstanding the provisions of the copyright clause related to the text of this ETS, ETSI grants that users of this ETS may freely reproduce the PCTR proforma in this annex so that it can be used for its intended purposes and may further publish the completed PCTR.

The PCTR Proforma is based on ISO/IEC 9646-6 [15]. Any additional information needed can be found in this document.

C.1 Identification summary

C.1.1 Protocol conformance test report

Table C.1

PCTR Number:	
PCTR Date:	
Corresponding SCTR Number:	
Corresponding SCTR Date:	
Test Laboratory Identification:	
Test Laboratory Manager:	
Signature:	

C.1.2 IUT identification

Table C.2

Name:	
Version:	
Protocol specification:	
PICS:	
Previous PCTR if any:	

C.1.3 Testing environment

Table C.3

PIXIT Number:	
ATS Specification:	
Abstract Test Method:	Remote test method, Embedded variant with no UT
Means of Testing identification:	
Date of testing:	
Conformance Log reference(s):	
Retention Date for Log reference(s):	

C.1.4 Limits and reservation

Additional information relevant to the technical contents or further use of the test report, or the rights and obligations of the test laboratory and the client, may be given here. Such information may include restriction on the publication of the report.

.....
.....
.....
.....
.....

C.1.5 Comments

Additional comments may be given by either the client or the test laboratory on any of the contents of the PTR, for example, to note disagreement between the two parties.

.....
.....
.....
.....

C.2 IUT Conformance status

This IUT has or has not been shown by conformance assessment to be non conforming to the specified protocol specification.

Strike the appropriate words in this sentence. If the PICS for this IUT is consistent with the static conformance requirements (as specified in clause 3 in this report) and there are no "FAIL" verdicts to be recorded (in clause 6) strike the words "has or". otherwise strike the words "or has not".

C.3 Static conformance summary

The PICS for this IUT is or is not consistent with the static conformance requirements in the specified protocol.

Strike the appropriate words in this sentence.

C.4 Dynamic conformance summary

The test campaign did or did not reveal errors in the IUT.

Strike the appropriate words in this sentence. If there are no "FAIL" verdicts to be recorded (in clause 6 of this report) strike the words "did or" otherwise strike the words "or did not".

Summary of the results of groups of test:

.....
.....
.....
.....
.....
.....

C.6 Test campaign report

Table C.4

ATS Reference	Selected?	Run?	Verdict	Observations (Reference to any observations made in clause 7)
TC-U-CA-000	Yes/No	Yes/No		
TC-U-CA-001	Yes/No	Yes/No		
TC-U-CA-002	Yes/No	Yes/No		
TC-U-CA-003	Yes/No	Yes/No		
TC-U-BI-000	Yes/No	Yes/No		
TC-U-BI-001	Yes/No	Yes/No		
TC-U-BI-002	Yes/No	Yes/No		
TC-U-BI-003	Yes/No	Yes/No		
TC-U-BI-004	Yes/No	Yes/No		
TC-U-BI-005	Yes/No	Yes/No		
TC-U-BI-006	Yes/No	Yes/No		
TC-U-BI-007	Yes/No	Yes/No		
TC-A-CA-000	Yes/No	Yes/No		
TC-A-CA-001	Yes/No	Yes/No		
TC-A-CA-002	Yes/No	Yes/No		
TC-A-CA-003	Yes/No	Yes/No		
TC-A-CA-005	Yes/No	Yes/No		
TC-A-CA-006	Yes/No	Yes/No		
TC-A-CA-007	Yes/No	Yes/No		
TC-A-CA-008	Yes/No	Yes/No		
TC-A-BV-000	Yes/No	Yes/No		
TC-A-BV-002	Yes/No	Yes/No		
TC-A-BV-003	Yes/No	Yes/No		
TC-A-BV-005	Yes/No	Yes/No		
TC-A-BV-006	Yes/No	Yes/No		
TC-A-BV-007	Yes/No	Yes/No		
TC-A-BV-008	Yes/No	Yes/No		
TC-A-BI-000	Yes/No	Yes/No		
TC-A-BI-001	Yes/No	Yes/No		
TC-A-BI-002	Yes/No	Yes/No		
TC-A-BI-003	Yes/No	Yes/No		
TC-A-BI-004	Yes/No	Yes/No		
			(continued)	

Annex D (informative): Bibliography

The following references are provided for information.

- 1) EWOS/ETSI Project Team No 5: "Project Report and Technical Report. OSI Conformance Testing Methodology and Procedures in Europe".
- 2) ETR 022: "Advanced Testing Methods (ATM); Vocabulary of terms used in communications protocols conformance testing".
- 3) CEPT Recommendation T/SGT SF2 (89) 6/0: "Draft Recommendation T/SF Services and Facilities of Digital Enhanced Cordless Telecommunications".
- 4) ETR 015: "Radio Equipment and Systems (RES); Digital Enhanced Cordless Telecommunications (DECT); Reference document".
- 5) ETR 041 "Transmission and Multiplexing (TM); Digital Enhanced Cordless Telecommunications (DECT); Transmission aspects 3,1 kHz telephony Interworking with other networks".
- 6) ETR 042 "Radio Equipment and Systems (RES); Digital Enhanced Cordless Telecommunications (DECT); A Guide to DECT features that influence the traffic capacity and the maintenance of high radio link transmission quality, including the results of simulations"
- 7) ETR 043: "Radio Equipment and Systems (RES); Digital Enhanced Cordless Telecommunications (DECT); Common interface; Services and Facilities requirements specification".
- 8) ETR 056: "Radio Equipment and Systems (RES); Digital Enhanced Cordless Telecommunications (DECT); System description document".

History

Document history	
August 1996	First Edition
February 1997	Public Enquiry PE 9724: 1997-02-14 to 1997-06-13