



**E**UROPEAN  
**T**ELECOMMUNICATION  
**S**TANDARD

**FINAL DRAFT**  
pr **ETS 300 497-4**

November 1997

**Second Edition**

---

Source: DECT

Reference: RE/DECT-040094-4

ICS: 33.020

**Key words:** ATS, DECT, radio, testing, TSS&TP

**Digital Enhanced Cordless Telecommunications (DECT);  
Common Interface (CI) Test Case Library (TCL);  
Part 4: Test Suite Structure (TSS) and Test Purposes (TP) -  
Data Link Control (DLC) layer**

**ETSI**

European Telecommunications Standards Institute

**ETSI Secretariat**

**Postal address:** F-06921 Sophia Antipolis CEDEX - FRANCE

**Office address:** 650 Route des Lucioles - Sophia Antipolis - Valbonne - FRANCE

**X.400:** c=fr, a=atlas, p=etsi, s=secretariat - **Internet:** secretariat@etsi.fr

Tel.: +33 4 92 94 42 00 - Fax: +33 4 93 65 47 16

---

**Copyright Notification:** No part may be reproduced except as authorized by written permission. The copyright and the foregoing restriction extend to reproduction in all media.

© European Telecommunications Standards Institute 1997. All rights reserved.



## Contents

Foreword .....	5
1 Scope .....	7
2 Normative references .....	7
3 Definitions and abbreviations .....	8
3.1 Definitions .....	8
3.2 Abbreviations .....	10
4 Test Suite Structure (TSS) .....	11
4.1 Overview .....	11
4.2 TSS .....	12
4.3 Test groups .....	13
4.3.1 Protocol groups .....	13
4.3.1.1 C-plane .....	13
4.3.1.2 U-plane .....	13
4.3.2 Main test groups .....	13
4.3.2.1 Capability (CA) tests .....	13
4.3.2.2 Valid Behaviour (BV) tests .....	13
4.3.2.3 Inopportune Behaviour (BO) tests .....	13
4.3.2.4 Invalid Behaviour (BI) tests .....	13
5 Test Purposes (TP) .....	14
5.1 Introduction .....	14
5.1.1 TP definition conventions .....	14
5.1.2 TP naming conventions .....	14
5.1.3 Sources of TP definitions .....	14
5.2 C-plane .....	15
5.2.1 LAPC Class U service .....	15
5.2.1.1 CA tests .....	15
5.2.1.2 BV tests .....	15
5.2.1.3 BI tests .....	16
5.2.1.4 BO tests .....	16
5.2.2 LAPC Class A service .....	17
5.2.2.1 CA tests .....	17
5.2.2.2 BV tests .....	19
5.2.2.3 BI tests .....	20
5.2.2.4 BO tests .....	22
5.2.3 LAPC Class B service .....	22
5.2.3.1 CA tests .....	22
5.2.3.2 BV tests .....	22
5.2.3.3 BI tests .....	22
5.2.3.4 BO tests .....	22
5.2.4 Broadcast service (Lb) .....	23
5.2.4.1 CA tests .....	23
5.2.4.2 BV tests .....	23
5.2.4.3 BI tests .....	23
5.2.4.4 BO tests .....	23
5.3 U-plane .....	23
5.3.1 Class 0 transmission procedures .....	23
5.3.1.1 CA tests .....	23
5.3.1.2 BV tests .....	23
5.3.1.3 BI tests .....	24
5.3.1.4 BO tests .....	24
5.3.2 Class 1 transmission procedures .....	24
5.3.2.1 CA tests .....	24

	5.3.2.2	BV tests .....	24
	5.3.2.3	BI tests .....	24
	5.3.2.4	BO tests .....	24
5.3.3		Class 2 transmission procedures .....	25
	5.3.3.1	CA tests.....	25
	5.3.3.2	BV tests.....	25
	5.3.3.3	BI tests .....	25
	5.3.3.4	BO tests .....	25
5.3.4		Class 3 transmission procedures .....	25
	5.3.4.1	CA tests.....	25
	5.3.4.2	BV tests.....	25
	5.3.4.3	BI tests .....	25
	5.3.4.4	BO tests .....	25
Annex A (informative):		Bibliography .....	26
History .....			27

## Foreword

This final draft second edition European Telecommunication Standard (ETS) has been produced by the Digital Enhanced Cordless Telecommunications (DECT) Project of the European Telecommunications Standards Institute (ETSI), and is now submitted for the Voting phase of the ETSI standards approval procedure.

This ETS comprises nine parts, as follows:

- Part 1: "Test Suite Structure (TSS) and Test Purposes (TP) for Medium Access Control (MAC) layer";
- Part 2: "Abstract Test Suite (ATS) for Medium Access Control (MAC) layer - Portable radio Termination (PT)";
- Part 3: "Abstract Test Suite (ATS) for Medium Access Control (MAC) layer - Fixed radio Termination (FT)";
- Part 4: "Test Suite Structure (TSS) and Test Purposes (TP) - Data Link Control (DLC) layer";**
- Part 5: "Abstract Test Suite (ATS) - Data Link Control (DLC) layer";
- Part 6: "Test Suite Structure (TSS) and Test Purposes (TP) - Network (NWK) layer - Portable radio Termination (PT)";
- Part 7: "Abstract Test Suite (ATS) for Network (NWK) layer - Portable radio Termination (PT)";
- Part 8: "Test Suite Structure (TSS) and Test Purposes (TP) - Network (NWK) layer - Fixed radio Termination (FT)";
- Part 9: "Abstract Test Suite (ATS) for Network (NWK) layer - Fixed radio Termination (FT)".

<b>Proposed transposition dates</b>	
Date of latest announcement of this ETS (doa):	3 months after ETSI publication
Date of latest publication of new National Standard or endorsement of this ETS (dop/e):	6 months after doa
Date of withdrawal of any conflicting National Standard (dow):	6 months after doa

Blank page

## 1 Scope

This European Telecommunication Standard (ETS) contains the Test Suite Structure (TSS) and Test Purposes (TP) to test the Digital Enhanced Cordless Telecommunications (DECT) Data Link Control (DLC) layer.

The objective of this test specification is to provide a basis for approval tests for DECT equipment giving a high probability of air interface inter-operability between different manufacturer's DECT equipment.

The ISO standard for the methodology of conformance testing (ISO/IEC 9646-1 [10] and ISO/IEC 9646-2 [11]) as well as the ETSI rules for conformance testing (ETS 300 406 [9]) are used as the basis for the test methodology.

Test specifications for the Physical Layer (PHL), Medium Access Control (MAC) layer, and Network (NWK) layer are provided in other the DECT standards.

## 2 Normative references

This ETS incorporates, by dated or undated reference, provisions from other publications. These normative references are cited at the appropriate places in the text and the publications are listed hereafter. For dated references, subsequent amendments to or revisions of any of these publications apply to this ETS only when incorporated in it by amendment or revision. For undated references the latest edition of the publication referred to applies.

- [1] ETS 300 175-1: "Digital Enhanced Cordless Telecommunications (DECT); Common Interface (CI); Part 1: Overview".
- [2] ETS 300 175-2: "Digital Enhanced Cordless Telecommunications (DECT); Common Interface (CI); Part 2: Physical layer (PHL)".
- [3] ETS 300 175-3: "Digital Enhanced Cordless Telecommunications (DECT); Common Interface (CI); Part 3: Medium Access Control (MAC) layer".
- [4] ETS 300 175-4: "Digital Enhanced Cordless Telecommunications (DECT); Common Interface (CI); Part 4: Data Link Control (DLC) layer".
- [5] ETS 300 175-5: "Digital Enhanced Cordless Telecommunications (DECT); Common Interface (CI); Part 5: Network (NWK) layer".
- [6] ETS 300 175-6: "Digital Enhanced Cordless Telecommunications (DECT); Common Interface (CI); Part 6: Identities and addressing".
- [7] ETS 300 175-7: "Digital Enhanced Cordless Telecommunications (DECT); Common Interface (CI); Part 7: Security features".
- [8] ETS 300 175-8: "Digital Enhanced Cordless Telecommunications (DECT); Common Interface (CI); Part 8: Speech coding and transmission".
- [9] ETS 300 406: "Methods for Testing and Specification (MTS); Protocol and profile conformance testing specifications; Standardization methodology".
- [10] ISO/IEC 9646-1 (1991): "Information technology - Open Systems Interconnection - Conformance testing methodology and framework - Part 1: General concepts". (See also CCITT Recommendation X.290 (1991)).
- [11] ISO/IEC 9646-2 (1991): "Information technology - Open Systems Interconnection - Conformance testing methodology and framework - Part 2: Abstract test suite specification". (See also CCITT Recommendation X.291 (1991)).
- [12] ISO 7498: "Information Processing Systems - Open Systems Interconnection - Basic Reference model".

- [13] 91/263/EEC: "Council Directive of 29 April 1991 on the approximation of the laws of the Member States concerning telecommunications terminal equipment, including the mutual recognition of their conformity" (Terminal Directive).
- [14] TBR 6: "Digital Enhanced Cordless Telecommunications (DECT); General terminal attachment requirements".
- [15] TBR 10: "Digital Enhanced Cordless Telecommunications (DECT); General terminal attachment requirements; Telephony applications".
- [16] TBR 22: "Attachment requirements for terminal equipment for Digital Enhanced Cordless Telecommunications (DECT) Generic Access Profile (GAP) applications".

### 3 Definitions and abbreviations

#### 3.1 Definitions

For the purposes of this ETS, the following definitions apply:

**Abstract Test Suite (ATS):** See ISO/IEC 9646-1 [10].

**bearer handover:** The internal handover process provided by the Medium Access Control (MAC) layer, whereby one MAC connection can modify its underlying bearers while maintaining the service provided to the Data Link Control (DLC) layer.

NOTE 1: Bearer handover is slot based.

**C-plane:** The Control plane of the DECT protocol stacks, which contains all the internal DECT protocol control, but may also include some external user information.

NOTE 2: The C-plane stack always contains protocol entities up to and including the network layer.

**cluster:** A logical grouping of one or more cells between which bearer handover is possible. A cluster control function controls one cluster.

NOTE 3: Internal handover to a cell which is not part of the same cluster can only be done by connection handover.

**connection handover:** The internal handover process provided by the DLC layer, whereby one set of DLC entities (Control plane and User plane) can reroute data from one MAC connection to a second new MAC connection, while maintaining the service provided to the network layer.

NOTE 4: Connection handover is DLC frame based.

**Connectionless mode (C/L):** A transmission mode that transfers one packet (one self contained unit) of data from one source point to one (or more) destination points in a single phase.

NOTE 5: Connectionless transmissions require the peer-to-peer associations to be pre-arranged, and the transmission is unacknowledged at that layer.

**Connection Oriented mode (C/O):** A transmission mode that transfers data from one source point to one or more destination points using a protocol based on three phases: "set-up", "data transfer" and "release".

NOTE 6: Connection oriented mode requires no prearranged associations between peer entities (unlike C/L mode).

**DLC broadcast:** A simplex "connectionless" mode of transmission from the DLC broadcast entity (Lb) of one fixed radio termination to the DLC broadcast entities (Lbs) in one or more portable radio terminations.

NOTE 7: The transmitter may disregard the presence or absence of receivers.



**DLC data link (DLC link):** An association between two DLC layer entities. This can either be one C-plane association or one U-plane association.

NOTE 8: This is not the same as a MAC connection.

**DLC Frame:** The format used to structure all messages that are exchanged between DLC layer peer entities.

NOTE 9: Different DLC frames are used in the C-plane and the U-plane, and there is more than one format of DLC frame in each plane.

**Fixed radio Termination (FT):** A logical group of functions that contains all the DECT processes and procedures on the fixed side of the DECT air interface.

NOTE 10: A fixed radio termination only includes elements that are defined in the ETS 300 175. This includes radio transmission elements (layer 1) together with a selection of layer 2 and layer 3 elements.

**flow control:** The mechanism that is used to regulate the flow of data between two peer entities.

**fragment:** One of the service data units that is produced by the process of fragmentation.

NOTE 11: This is not the same as a segment.

**fragmentation:** The process of dividing a protocol data unit into more than one service data unit for delivery to a lower layer. The reverse process is recombination.

NOTE 12: This is not the same as segmentation.

**Implementation Under Test (IUT):** See ISO/IEC 9646-1 [10].

**Lower Layer Management Entity (LLME):** A management entity that spans a number of lower layers, and is used to describe all control activities which do not follow the rules of layering.

NOTE 13: The DECT LLME spans the network layer, the DLC layer, the MAC layer and the physical layer.

**Lower Tester (LT):** See ISO/IEC 9646-1 [10].

**Network Layer (NWK):** See ISO 7498 [12].

**Physical Layer (PHL):** See ISO 7498 [12].

**Point of Control and Observation (PCO):** See ISO/IEC 9646-1 [10].

**Portable radio Termination (PT):** A logical group of functions that contains all the DECT processes and procedures on the portable side of the DECT air interface.

NOTE 14: A portable radio termination only includes elements that are defined in ETS 300 175 [1] to [8]. This includes radio transmission elements (layer 1) together with a selection of layer 2 and layer 3 elements.

**Protocol Implementation Conformance Statement (PICS):** See ISO/IEC 9646-1 [10].

**Protocol Implementation Extra Information for Testing (PIXIT):** See ISO/IEC 9646-1 [10].

**PICS proforma:** See ISO/IEC 9646-1 [10].

**PIXIT proforma:** See ISO/IEC 9646-1 [10].

**Radio Fixed Part (RFP):** One physical sub-group of a fixed part that contains all the radio end points (one or more) that are connected to a single system of antennas.

**segment:** One of the pieces of data that is produced by the process of segmentation.

NOTE 15: In general, one segment only represents a portion of a complete message.

**segmentation:** The process of partitioning one service data unit from a higher layer into more than one protocol data unit. The reverse process is assembly.

**sequencing (sequence numbering):** The process of adding a sequence number to a set of data packets so that the packets can be reassembled in the correct order, regardless of the order in which they are received. See also segmentation.

**U-plane:** The User plane of the DECT protocol stacks. This plane contains most of the end-to-end (external) user information and user control.

NOTE 16: The U-plane protocols do not include any internal DECT protocol control, and it may be null at the network layer and at the DLC layers for some services.

**Upper Tester (UT):** See ISO/IEC 9646-1 [10].

### 3.2 Abbreviations

For the purposes of this ETS, the following abbreviations apply:

BI	Invalid Behaviour
BO	Inopportune Behaviour
BV	Valid Behaviour
C/L	Connectionless mode
C/O	Connection Oriented mode
CA	Capability tests
C-plane	Control plane
DECT	Digital Enhanced Cordless Telecommunications
DLC	Data Link Control layer
FP	Fixed Part
FT	Fixed radio Termination
IUT	Implementation Under Test
LAPC	a DLC layer C-plane protocol entity
Lb	a DLC broadcast entity
LLME	Lower Layer Management Entity
LT	Lower Tester
MAC	Medium Access Control layer
NWK	Network layer
PDU	Protocol Data Unit
PHL	Physical Layer
PICS	Protocol Implementation Conformance Statement
PIXIT	Protocol Implementation Extra Information for Testing
PP	Portable Part
PT	Portable radio Termination
RFP	Radio Fixed Part
SAPI	Service Access Point Identifier
TDMA	Time Division Multiple Access
TP	Test Purposes
TSS	Test Suite Structure
ULI	Unassigned Link Identifier (U-Plane)
U-plane	User plane

## 4 Test Suite Structure (TSS)

### 4.1 Overview

The Data Link Control (DLC) layer is layer 2b of the DECT protocol stack. The separation of the user information from the DECT signalling data is managed by the allocation of two independent planes:

- the User plane (U-plane); and
- the Control plane (C-plane).

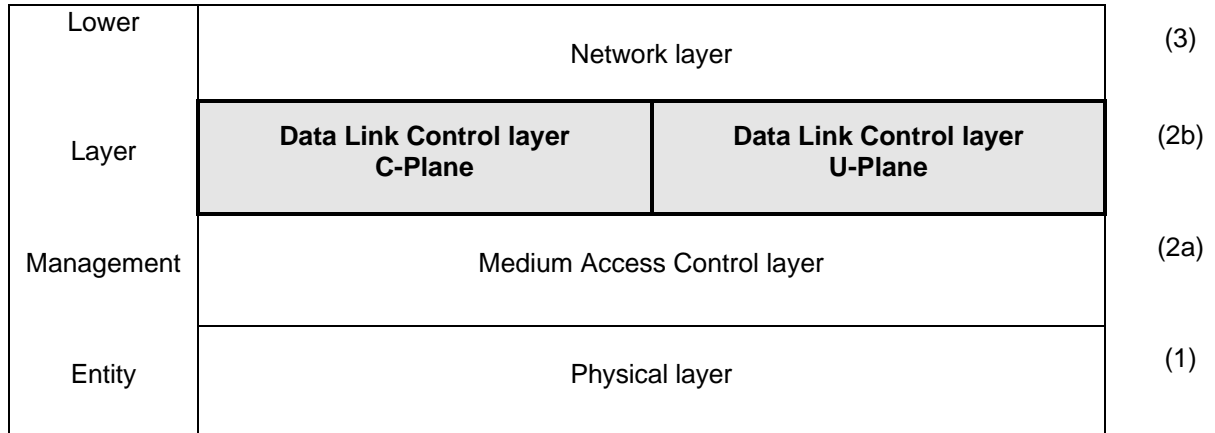

**Figure 1: DECT protocol stack**

The U-plane is the part of the DLC implementation that is responsible for the transmission of the user data. The U-plane may provide a series of different services and facilities, grouped into categories (LUx families).

The C-Plane is the second part of DECT DLC and is mainly involved with the transfer of signalling information. It provides the means to support DECT Connection Oriented, Connectionless and Broadcast services (the broadcast service exists only at the FT to PT direction). DECT DLC provides three classes of operation (Unacknowledged for C/L services, Single frame and Multiframe for C/O services).

At the DLC layer, C-plane and U-plane resources are considered as completely independent. The association of C and U-plane resources to serve a higher layer service (e.g. to setup and maintain a call) is a NWK layer responsibility. Moreover, no interaction is required between the services provided by each of the planes.

Figure 2 shows the DLC (TSS) including its subgroups and defined for the conformance testing.

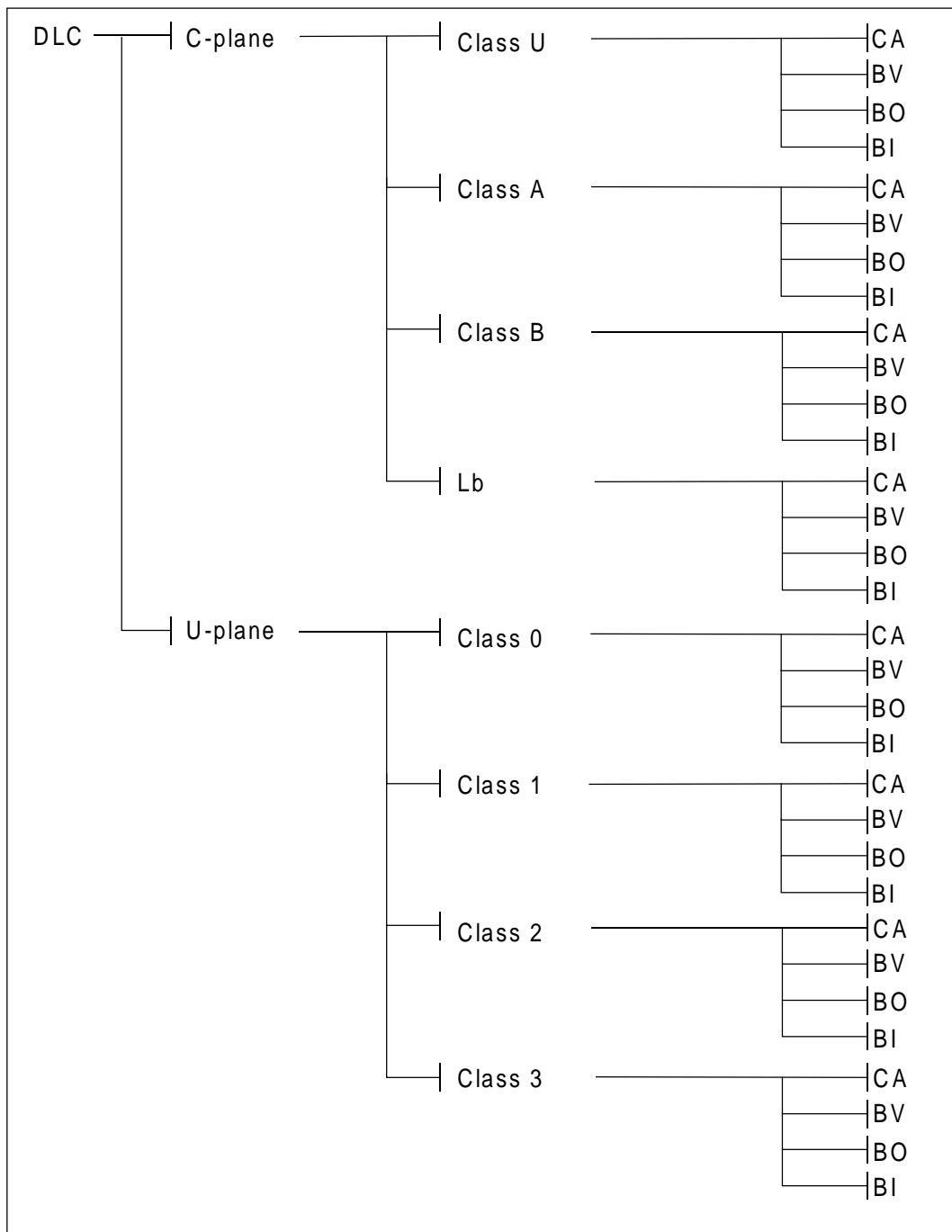

Figure 2: DLC TSS

#### 4.2 TSS

The test suite is structured as a tree with a first level defined as DLC representing the protocol group "DLC for Portable Part (PP) and Fixed Part (FP)".

### 4.3 Test groups

The test groups are organised in three levels. The first level creates two protocol groups representing the protocol plane. The second level separates the protocol plane in functional modules. The last level contains the standard ISO subgroups CA, BV, BO and BI.

#### 4.3.1 Protocol groups

The protocol groups identifies the DECT DLC planes, C-Plane and U-Plane, as defined in ETS 300 175 [1] to [8].

##### 4.3.1.1 C-plane

The C-plane protocol group is divided in four functional modules. The first functional module identifies the LAPC Class U services. The second functional module identifies the LAPC Class A services. The third functional module identifies the LAPC Class B services. The last functional module identifies the broadcast services Lb.

##### 4.3.1.2 U-plane

The U-plane protocol group is divided in four functional modules. The first functional module identifies the Class 0 transmission procedures. The second functional module identifies the Class 1 transmission procedures. The third functional module identifies the Class 2 transmission procedures. The last functional module identifies the Class 3 transmission procedures.

#### 4.3.2 Main test groups

The main test groups are the Capability group (CA), the Valid Behaviour group (BV), the inopportune Behaviour group (BO) and the Invalid Behaviour group (BI).

##### 4.3.2.1 Capability (CA) tests

This test sub group shall provide limited testing of the major IUT capabilities aiming to assure that the claimed capabilities are correctly supported, in accordance with the PICS.

##### 4.3.2.2 Valid Behaviour (BV) tests

This test sub group shall verify that the IUT reacts in conformity with the standard, on receipt or exchange of a valid Protocol Data Units (PDUs). Valid PDUs, means, that the exchange of messages and the content of the exchanged messages are considered as valid.

##### 4.3.2.3 Inopportune Behaviour (BO) tests

This test sub group shall verify that the IUT is capable of a valid reaction, when an inopportune protocol event occurs. Such an event is syntactically correct but it occurs when it is not expected.

##### 4.3.2.4 Invalid Behaviour (BI) tests

This test sub group shall verify that the IUT reacts in conformity with the standard, on receipt of a syntactically invalid Protocol Data Unit (PDU).

## 5 Test Purposes (TP)

### 5.1 Introduction

#### 5.1.1 TP definition conventions

The TPs are defined following particular rules as shown in the table 1.

**Table 1: TP definition rules**

TP Id according to the TP naming conventions	Reference Initial condition Stimulus Expected behaviour
TP Id	The TP Id is a unique identifier it shall be specified according to the TP naming conventions defined in the subclause below.
Reference	The reference should contain the references of the subject to be validated by the actual TP (specification reference, clause, paragraph).
Condition	The condition defines in which initial state the IUT has to be to apply the actual TP.
Stimulus	The stimulus defines the test event to which the TP is related.
Expected behaviour	Definition of the events that are expected from the IUT to conform to the base specification.

#### 5.1.2 TP naming conventions

The identifier of the TP is built according to table 2:

**Table 2: TP naming convention**

Identifier:	TP<fm>x-<nnn>		
	<fm> = functional module	U A B L 0 1 2 3	C-plane Class U services C-plane Class A services C-plane Class B services C-plane Broadcast services U-plane transmission Class 0 U-plane transmission Class 1 U-plane transmission Class 2 U-plane transmission Class 3
	x = Type of testing	C V O I	CA, Capability Tests BV, Valid Behaviour Tests BO, Inopportune Behaviour Tests BI, Invalid Behaviour Tests
	<nnn> = sequential number	(000-999)	Test Purpose Number

#### 5.1.3 Sources of TP definitions

All TPs are specified according to ETS 300 175-4 [4]. The functions of the LC entity (frame delimiting, checksum generation/checking, fragmentation of DLC frames, and routing of frame to/from logical channels) are implicitly covered by the TP designed for the C-plane.

## 5.2 C-plane

### 5.2.1 LAPC Class U service

#### 5.2.1.1 CA tests

<b>DLC/C-Plane/ClassU/TPUC-000</b>	ETS 300 175-4 [4], subclause 9.3. Only applicable when a procedure is specified in the PIXIT to force the IUT to send an UI frame. Verify that the IUT is able to generate an UI frame by using MAC connectionless services.
<b>DLC/C-Plane/ClassU/TPUC-001</b>	ETS 300 175-4 [4], subclause 9.3. Only applicable when a procedure is specified in the PIXIT to force the IUT to send an UI frame. Verify that the IUT is able to generate an UI frame by using an open MAC connection.
<b>DLC/C-Plane/ClassU/TPUC-002</b>	ETS 300 175-4 [4], subclause 9.3. Only applicable when a procedure is specified in the PIXIT to determine UI frame reception. Verify that the IUT is able to receive an UI frame over MAC connectionless services.
<b>DLC/C-Plane/ClassU/TPUC-003</b>	ETS 300 175-4 [4], subclause 9.3. Only applicable when a procedure is specified in the PIXIT to determine UI frame reception. Verify that the IUT is able to receive an UI frame over an open MAC connection.

#### 5.2.1.2 BV tests

<b>DLC/C-Plane/ClassU/TPUV-000</b>	ETS 300 175-4 [4], subclause 9.3.2. Only applicable when a procedure is specified in the PIXIT to determine UI frame reception. Verify that the IUT, on receipt of the first UI frame in an open MAC connection, considers the Class U link as established.
<b>DLC/C-Plane/ClassU/TPUV-001</b>	ETS 300 175-4 [4], subclause 9.3.4. Only applicable when a procedure is specified in the PIXIT to determine UI frame reception. Verify that the IUT, on receipt of the a Class U upward release from the peer DLC entity in an open MAC connection, considers the Class U link as released.

## 5.2.1.3 BI tests

<b>DLC/C-Plane/ClassU/TPUI-000</b>	ETS 300 175-4 [4], subclause 9.3.3.2. Only applicable when a procedure is specified in the PIXIT to determine UI frame reception. Verify that the IUT, on receipt of an UI frame with P bit set to '1', accepts this erroneous frame. The UI frame is transmitted over MAC connectionless services.
<b>DLC/C-Plane/ClassU/TPUI-001</b>	ETS 300 175-4 [4], subclause 9.3.3.2. Only applicable when a procedure is specified in the PIXIT to determine UI frame reception. Verify that the IUT, on receipt of an UI frame with P bit set to '1', accepts this erroneous frame. The UI frame is transmitted over an open MAC connection.
<b>DLC/C-Plane/ClassU/TPUI-002</b>	ETS 300 175-4 [4], subclause 9.3.3.2. Only applicable when a procedure is specified in the PIXIT to determine UI frame reception. Verify that the IUT, on receipt of an UI frame with NLF bit set to '1', accepts this erroneous frame. The UI frame is transmitted over MAC connectionless services.
<b>DLC/C-Plane/ClassU/TPUI-003</b>	ETS 300 175-4 [4], subclause 9.3.3.2. Only applicable when a procedure is specified in the PIXIT to determine UI frame reception. Verify that the IUT, on receipt of an UI frame with NLF bit set to '1', accepts this erroneous frame. The UI frame is transmitted over an open MAC connection.
<b>DLC/C-Plane/ClassU/TPUI-004</b>	ETS 300 175-4 [4], subclause 9.3.3.2. Only applicable when a procedure is specified in the PIXIT to determine UI frame reception. Verify that the IUT discards a UI frame with improper LLN (not Class U operation). The UI frame is transmitted over MAC connectionless services.
<b>DLC/C-Plane/ClassU/TPUI-005</b>	ETS 300 175-4 [4], subclause 9.3.3.2. Only applicable when a procedure is specified in the PIXIT to determine UI frame reception. Verify that the IUT discards a UI frame with improper LLN (not Class U operation). The UI frame is transmitted over an open MAC connection.
<b>DLC/C-Plane/ClassU/TPUI-006</b>	ETS 300 175-4 [4], subclause 9.3.3.2. Only applicable when a procedure is specified in the PIXIT to determine UI frame reception. Verify that the IUT discards a UI frame with improper Service Access Point Identifier (SAPI) (not "connectionless"). The UI frame is transmitted over MAC connectionless services.
<b>DLC/C-Plane/ClassU/TPUI-007</b>	ETS 300 175-4 [4], subclause 9.3.3.2. Only applicable when a procedure is specified in the PIXIT to determine UI frame reception. Verify that the IUT discards a UI frame with improper SAPI (not "connection oriented"). The UI frame is transmitted over an open MAC connection.

## 5.2.1.4 BO tests

In an open MAC connection, transmitting or receiving UI frames is ever possible and inopportune TPs can not be defined.



## 5.2.2 LAPC Class A service

## 5.2.2.1 CA tests

<b>DLC/C-Plane/ClassA/TPAC-000</b>	<p>ETS 300 175-4 [4], subclause 9.2.3.1.  Only for IUT that is able to send the establishment request of the data link.  Initial condition: The IUT has sent the link establishment request and is now in establishment pending state.  Verify that the IUT re-transmits the same link establishment I-Frame request N250 times if, at each request, the timer &lt;DL-07&gt; expires and the expected RR response frame with the NLF bit set to '1' is not received and enters established state, if in the last re-transmission it receives the expected RR with the NLF bit set to '1'.</p>
<b>DLC/C-Plane/ClassA/TPAC-001</b>	<p>ETS 300 175-4 [4], subclause 9.2.3.1.  Only for IUT that is able to send the establishment request of the data link.  Initial condition: The IUT has sent the link establishment request and is now in establishment pending state.  Verify that the IUT, on receipt of a valid RR frame response to the link establishment request it has sent, enters established state.</p>
<b>DLC/C-Plane/ClassA/TPAC-002</b>	<p>ETS 300 175-4 [4], subclause 9.2.3.8.  Only for IUT that is able to send the establishment request of the data link.  Initial condition: The IUT has sent the link establishment request to re-establish the link and is now in re-establishment pending state.  Verify that the IUT re-transmits the same link establishment I-Frame request N250 times if, at each request, the timer &lt;DL-07&gt; expires and the expected RR response frame with the NLF bit set to '1' is not received and enters established state, if in the last re-transmission it receives the expected RR with the NLF bit set to '1'.</p>
<b>DLC/C-Plane/ClassA/TPAC-003</b>	<p>ETS 300 175-4 [4], subclause 9.2.3.8.  Only for IUT that is able to send the establishment request of the data link.  Initial condition: The IUT has sent the link establishment request to re-establish the link and is now in re-establishment pending state.  Verify that the IUT, on receipt of a valid RR frame response to the link re-establishment request it has sent, enters established state.</p>
	(continued)

## CA tests (concluded)

<b>DLC/C-Plane/ClassA/TPAC-005</b>	ETS 300 175-4 [4], subclause 9.2.3.4. Initial condition: The IUT is in Class A established state. Verify that the IUT acknowledges rightly a valid received I-Frame within timer <DL-04>.
<b>DLC/C-Plane/ClassA/TPAC-006</b>	ETS 300 175-4 [4], subclause 9.2.3.6. Initial condition: The IUT is in Class A established state. Verify that the IUT re-transmits N250 times the same I-Frame if, at each transmission, the timer <DL-04> expires and the expected acknowledgement is not received and remains in established state, if in the last re-transmission it receives the expected acknowledgement.
<b>DLC/C-Plane/ClassA/TPAC-007</b>	ETS 300 175-4 [4], subclause 9.2.2.1. For IUT that implement only Class A operation (no Class B). Initial condition: The IUT is in Unassigned Link Identifier (ULI) state. Verify that the IUT, on receipt of the Class B link establishment I-Frame request, refuses this request by sending RR response frame with the reserved LLN value "Class A operation" and NLF bit set to "1", and enters into the Class A established state.
<b>DLC/C-Plane/ClassA/TPAC-008</b>	ETS 300 175-4 [4], subclause 9.2.3.1. Initial condition: The IUT is in ULI state. Verify that the IUT, on receipt of a valid link establishment I-Frame request, responds with a RR response frame with the NLF bit set to "1" and enters into the Class A established state.

## 5.2.2.2 BV tests

<b>DLC/C-Plane/ClassA/TPAV-000</b>	ETS 300 175-4 [4], subclause 9.2.3.1. Only for IUT that is able to send and to receive the establishment request of the data link. Initial condition: The IUT has sent the link establishment request and is now in establishment pending state (timer <DL-07> is active). Verify that the IUT accepts an I-Frame indicating Class A link establishment, responds with a RR response frame with the NLF bit set and establishes Class A operation. (Collision of establishment requests)
<b>DLC/C-Plane/ClassA/TPAV-002</b>	ETS 300 175-4 [4], subclause 9.2.3.5. Initial condition: The IUT is in Class A established state and has sent an I-Frame. Verify that the IUT accepts as an acknowledgement for a previously transmitted I-Frame, a RR response frame with correct N(R) value.
<b>DLC/C-Plane/ClassA/TPAV-003</b>	ETS 300 175-4 [4], subclause 9.2.3.5. Initial condition: The IUT is in Class A established state and has sent an I-Frame. Verify that the IUT accepts as an acknowledgement for a previously transmitted I-Frame, an I-Frame command with correct N(S) and N(R) values.
<b>DLC/C-Plane/ClassA/TPAV-005</b>	ETS 300 175-4 [4], subclause 9.2.3.6. Initial condition: The IUT is in timer recovery phase. Verify that the IUT accepts as an acknowledgement for a previously transmitted I-Frame, a RR response frame with correct N(R) value and leaves the timer recovery phase.
<b>DLC/C-Plane/ClassA/TPAV-006</b>	ETS 300 175-4 [4], subclause 9.2.3.6. Initial condition: The IUT is in timer recovery phase. Verify that the IUT accepts as an acknowledgement for a previously transmitted I-Frame, an I-Frame with correct N(S) and N(R) values and leaves the timer recovery phase.
<b>DLC/C-Plane/ClassA/TPAV-007</b>	ETS 300 175-4 [4], subclause 9.2.7.3.1. Initial condition: The IUT is in established state. Verify that the IUT manages rightly the PT intracell procedure for connection handover.
<b>DLC/C-Plane/ClassA/TPAV-008</b>	ETS 300 175-4 [4], subclause 9.2.7.3.1. Initial condition: The IUT is in established state. Verify that the IUT manages rightly the PT intercell procedure for connection handover.

## 5.2.2.3 BI tests

<b>DLC/C-Plane/ClassA/TPAI-000</b>	ETS 300 175-4 [4], subclause 9.2.3.1. Only for IUT that is able to send the establishment request of the data link. Initial condition: The IUT has sent the link establishment request and is now in establishment pending state (timer <DL-07> is active). Verify that the IUT, on receipt of a RR Class B response frame with NLF bit set to '1', discards the received frame and, on expiration of the timer <DL-07>, re-transmits the establishment request.
<b>DLC/C-Plane/ClassA/TPAI-001</b>	ETS 300 175-4 [4], subclause 9.2.3.1. Only for IUT that is able to send the establishment request of the data link. Initial condition: The IUT has sent the link establishment request and is now in establishment pending state (timer <DL-07> is active). Verify that the IUT, on receipt of a RR response frame with NLF bit set to '1' and invalid N(R), discards the received RR response frame and, on expiration of the timer <DL-07>, re-transmits the establishment request.
<b>DLC/C-Plane/ClassA/TPAI-002</b>	ETS 300 175-4 [4], subclause 9.2.3.8. Only for IUT that is able to send the establishment request of the data link. Initial condition: The IUT has sent the establishment request to re-establish the link and is waiting for the acknowledgement of the request. Verify that the IUT, on receipt of a RR Class B response frame with NLF bit set to '1', discards the received frame and, on expiration of the timer <DL-07>, re-transmits the re-establishment request.
<b>DLC/C-Plane/ClassA/TPAI-003</b>	ETS 300 175-4 [4], subclause 9.2.3.8. Only for IUT that is able to send the establishment request of the data link. Initial condition: The IUT has sent the establishment request to re-establish the link and is waiting for the acknowledgement of the request. Verify that the IUT, on receipt of a RR response frame with NLF bit set to '1' and invalid N(R), discards the received RR response frame and, on expiration of the timer <DL-07>, re-transmits the re-establishment request.
<b>DLC/C-Plane/ClassA/TPAI-004</b>	ETS 300 175-4 [4], subclause 9.2.3.6. Initial condition: The IUT, in Class A established state, has sent an I-Frame and is waiting for the adequate acknowledgement. Verify that the IUT, on receipt of a RR Class B response frame with NLF bit set to '0', discards the received frame and, on expiration of the timer <DL-04>, re-transmits the unacknowledged I-Frame.
<b>DLC/C-Plane/ClassA/TPAI-005</b>	ETS 300 175-4 [4], subclause 9.2.3.5. Initial condition: The IUT, in Class A established state, has sent an I-Frame and is waiting for the adequate acknowledgement. Verify that the IUT, on receipt of a RR response frame with NLF bit set to '0' and invalid N(R), discards the received RR response frame and, on expiration of the timer <DL-04>, re-transmits the unacknowledged I-Frame.
	(continued)

## BI tests (concluded)

<b>DLC/C-Plane/ClassA/TPAI-006</b>	ETS 300 175-4 [4], subclause 9.2.3.5. Initial condition: The IUT, in Class A established state, has sent an I-Frame and is waiting for the adequate acknowledgement. Verify that the IUT, on receipt of an I-Frame with invalid N(R), accepts the received frame and, on expiration of the timer <DL-04>, re-transmits the unacknowledged I-Frame with N(R) set to correctly acknowledge the received I-Frame.
<b>DLC/C-Plane/ClassA/TPAI-007</b>	ETS 300 175-4 [4], subclause 9.2.3.4. Initial condition: The IUT, in Class A established state, has sent an I-Frame and is waiting for the adequate acknowledgement. Verify that the IUT, on receipt of an I-Frame with invalid N(S), responds with a RR response frame or an I-Frame indicating in the N(R) field the expected N(S) of the received I-Frame and accepts the N(R) of the I-Frame as an acknowledgement for the previously transmitted frame.
<b>DLC/C-Plane/ClassA/TPAI-008</b>	ETS 300 175-4 [4], subclause 9.2.3.6. Initial condition: The IUT, in Class A established state, has sent an I-Frame and is waiting for the adequate acknowledgement. Verify that the IUT, on receipt of an I-Frame with invalid N(S) and invalid N(R), responds with a RR response frame indicating in the N(R) field the expected N(S) of the received I-Frame, and, on expiration of the timer <DL-04>, re-transmits the unacknowledged I-Frame.
<b>DLC/C-Plane/ClassA/TPAI-009</b>	ETS 300 175-4 [4], subclause 9.2.3.6. Initial condition: The IUT is in timer recovery phase. Verify that the IUT, on receipt of a RR Class B response frame with NLF bit set to '0', discards the received frame, it remains in timer recovery phase, and, on expiration of the timer <DL-04>, re-transmits the unacknowledged I-Frame.
<b>DLC/C-Plane/ClassA/TPAI-011</b>	ETS 300 175-4 [4], subclause 9.2.3.6. Initial condition: The IUT is in timer recovery phase. Verify that the IUT, on receipt of an I-Frame with invalid N(R), accepts the received I-Frame and responds with an appropriate RR frame and, on expiration of the timer <DL-04>, re-transmits the unacknowledged I-Frame with N(R) set according to the last accepted I-Frame.
<b>DLC/C-Plane/ClassA/TPAI-012</b>	ETS 300 175-4 [4], subclause 9.2.3.6. Initial condition: The IUT is in timer recovery phase. Verify that the IUT, on receipt of an I-Frame with invalid N(S), responds with an RR response frame or an I-frame, indicating in the N(R) field the expected N(S) of the received I-Frame, and leaves timer recovery phase because the N(R) of the received I-Frame is a valid acknowledgement for the I-Frame it has previously transmitted.
<b>DLC/C-Plane/ClassA/TPAI-013</b>	ETS 300 175-4 [4], subclause 9.2.3.6. Initial condition: The IUT is in timer recovery phase. Verify that the IUT, on receipt of an I-Frame with invalid N(S) and invalid N(R), responds with a RR response frame indicating in the N(R) field the N(S) of the expected I-Frame and, re-transmits the last unacknowledged I-Frame.

**5.2.2.4 BO tests**

<b>DLC/C-Plane/ClassA/TPAO-000</b>	ETS 300 175-4 [4], subclause 9.2.3.1. Only for IUT that is able to send the establishment request of the data link. Initial condition: The IUT has sent the link establishment request and is now in establishment pending state. Verify that the IUT, on receipt of an I-Frame with NLF bit set to '0', discards the received frame and, on expiration of the timer <DL-07>, re-transmits the establishment request.
<b>DLC/C-Plane/ClassA/TPAO-001</b>	ETS 300 175-4 [4], subclause 9.2.3.1. Only for IUT that is able to send the establishment request of the data link. Initial condition: The IUT has sent the link establishment request and is now in establishment pending state. Verify that the IUT, on receipt of a RR response frame with NLF bit set to '0', discards the received RR response frame and, on expiration of the timer <DL-07>, re-transmits the establishment request.
<b>DLC/C-Plane/ClassA/TPAO-002</b>	ETS 300 175-4 [4], subclause 9.2.3.8. Only for IUT that is able to send the establishment request of the data link. Initial condition: The IUT has sent the establishment request to re-establish the link and is waiting for the acknowledgement of the request. Verify that the IUT, on receipt of an I-Frame with NLF bit set to '0', discards the received frame and, on expiration of the timer <DL-07>, re-transmits the re-establishment request.
<b>DLC/C-Plane/ClassA/TPAO-003</b>	ETS 300 175-4 [4], subclause 9.2.3.8. Only for IUT that is able to send the establishment request of the data link. Initial condition: The IUT has sent the establishment request to re-establish the link and is waiting for the acknowledgement of the request. Verify that the IUT, on receipt of a RR response frame with NLF bit set to '0', discards the received RR response frame and, on expiration of the timer <DL-07>, re-transmits the re-establishment request.

**5.2.3 LAPC Class B service****5.2.3.1 CA tests**

No TPs are defined for LAPC Class B service CA tests in this ETS.

**5.2.3.2 BV tests**

No TPs are defined for LAPC Class B service BV tests in this ETS.

**5.2.3.3 BI tests**

No TPs are defined for LAPC Class B service BI tests in this ETS.

**5.2.3.4 BO tests**

No TPs are defined for LAPC Class B service BO tests in this ETS.

**5.2.4 Broadcast service (Lb)****5.2.4.1 CA tests**

<b>DLC/C-Plane/Lb/TPLC-000</b>	ETS 300 175-4 [4], subclause 5.2. For Fixed radio termination only. Verify that the IUT is able to generate a broadcast frame of the short frame format (3 octets). For Portable radio termination only. Verify that the IUT is able to receive a broadcast frame of the short frame format (3 octets).
<b>DLC/C-Plane/Lb/TPLC-001</b>	ETS 300 175-4 [4], subclause 5.2. For Fixed radio termination only. Verify that the IUT is able to generate a broadcast frame of the long frame format (5 octets). For Portable radio termination only. Verify that the IUT is able to receive a broadcast frame of the long frame format (5 octets).
<b>DLC/C-Plane/Lb/TPLC-002</b>	ETS 300 175-4 [4], subclause 9.4. For Fixed radio termination only. Verify that the IUT is able to transmit expedited broadcast message and normal broadcast message with prioritised queuing. For Portable radio termination only. Verify that the IUT is able to receive expedited broadcast message and normal broadcast message with prioritised queuing.

**5.2.4.2 BV tests**

No valid behaviour TP are defined because no statements are provided in the standard in case of reception or transmission of a broadcast message.

**5.2.4.3 BI tests**

No invalid behaviour TP are defined because the broadcast message content is only composed of higher layer information.

**5.2.4.4 BO tests**

No inopportune behaviour TP are defined because it is ever possible to receive or to transmit a broadcast message.

**5.3 U-plane****5.3.1 Class 0 transmission procedures****5.3.1.1 CA tests**

<b>DLC/U-Plane/Class0/TP0C-000</b>	ETS 300 175-4 [4], subclause 14.3.2.1. Verify that the IUT is able to transmit a correct U-plane Class 0 frame.
<b>DLC/U-Plane/Class0/TP0C-001</b>	ETS 300 175-4 [4], subclause 14.3.2.2. Verify that the IUT is able to receive a correct U-plane Class 0 frame.

**5.3.1.2 BV tests**

No valid behaviour TP are defined because Class 0 transmission provides no mechanisms for re-transmission or sequencing.

**5.3.1.3 BI tests**

No invalid behaviour TP are defined because, in Class 0 U-plane transmission, all frames are ever syntactically correct.

**5.3.1.4 BO tests**

No inopportune behaviour TP are defined because, in a Class 0 U-plane transmission, it is always possible to receive or to transmit a message.

**5.3.2 Class 1 transmission procedures****5.3.2.1 CA tests**

<b>DLC/U-Plane/Class1/TP1C-000</b>	ETS 300 175-4 [4], subclause 14.3.3.1. Verify that the IUT is able to transmit a correct U-plane Class 1 frame.
<b>DLC/U-Plane/Class1/TP1C-001</b>	ETS 300 175-4 [4], subclause 14.3.3.1. Verify that the IUT treats a received frame including an RN with the A/N bit set to '1', as an acknowledgement for all frames up to and including frame number RN.
<b>DLC/U-Plane/Class1/TP1C-002</b>	ETS 300 175-4 [4], subclause 14.3.3.2. Verify that the IUT correctly acknowledges received frame(s) with appropriate send sequence number(s). (In-sequence frames)

**5.3.2.2 BV tests**

<b>DLC/U-Plane/Class1/TP1V-000</b>	ETS 300 175-4 [4], subclause 14.3.3.1. Verify that the IUT disconnects the U-plane link, at the event of expiration of timer <DLU-01> without receiving the requested acknowledgement.
<b>DLC/U-Plane/Class1/TP1V-001</b>	ETS 300 175-4 [4], subclause 14.3.3.1. Verify that the IUT resets timer <DLU-01> on receipt of a frame that includes a valid acknowledgement.
<b>DLC/U-Plane/Class1/TP1V-002</b>	ETS 300 175-4 [4], subclause 14.3.3.1. Verify that the IUT maintains the <DLU-01> timer whenever the window size is reached (thereby halting further transmissions).

**5.3.2.3 BI tests**

<b>DLC/U-Plane/Class1/TP1I-000</b>	ETS 300 175-4 [4], subclause 14.3.3.1. Verify that the IUT discards a received frame with an I/R bit set to '0'.
<b>DLC/U-Plane/Class1/TP1I-001</b>	ETS 300 175-4 [4], subclause 14.3.3.1. Verify that the IUT discards a received frame with an A/N bit set to '0'.
<b>DLC/U-Plane/Class1/TP1I-002</b>	ETS 300 175-4 [4], subclause 14.3.3.2. Verify that the IUT correctly acknowledges received frame(s) with erroneous send sequence number(s) after waiting for L(R) Time Division Multiple Access (TDMA) frames. (Out-of-sequence frames)

**5.3.2.4 BO tests**

No inopportune behaviour TP are defined because, in a Class 1 U-plane transmission, it is always possible to receive or to transmit a message.



### **5.3.3 Class 2 transmission procedures**

#### **5.3.3.1 CA tests**

No TPs are defined for Class 2 transmission procedures CA tests in this ETS.

#### **5.3.3.2 BV tests**

No TPs are defined for Class 2 transmission procedures BV tests in this ETS.

#### **5.3.3.3 BI tests**

No TPs are defined for Class 2 transmission procedures BI tests in this ETS.

#### **5.3.3.4 BO tests**

No inopportune behaviour TP are defined because, in a class 2 U-plane transmission, it is always possible to receive or to transmit a message.

### **5.3.4 Class 3 transmission procedures**

#### **5.3.4.1 CA tests**

No TPs are defined for Class 3 transmission procedures CA tests in this ETS.

#### **5.3.4.2 BV tests**

No TPs are defined for Class 3 transmission procedures BV tests in this ETS.

#### **5.3.4.3 BI tests**

No TPs are defined for Class 3 transmission procedures BI tests in this ETS.

#### **5.3.4.4 BO tests**

No inopportune behaviour TP are defined because, in a Class 3 U-plane transmission, it is always possible to receive or to transmit a message.

## **Annex A (informative): Bibliography**

- 1) EWOS/ETSI Project Team No 5: "Project Report and Technical Report. OSI Conformance Testing Methodology and Procedures in Europe".
- 2) ETR 022: "Advanced Testing Methods (ATM); Vocabulary of terms used in communications protocols conformance testing".
- 3) ETR 141: "Methods for Testing and Specification (MTS); Protocol and profile conformance testing specifications; The Tree and Tabular Combined Notation (TTCN) style guide".
- 4) CEPT Recommendation T/SGT SF2 (89) 6/0: "Draft Recommendation T/SF Services and Facilities of Digital Enhanced Cordless Telecommunications".
- 5) ETR 015: "Digital Enhanced Cordless Telecommunications (DECT); Reference document".
- 6) ETR 041: "Transmission and Multiplexing (TM); Digital Enhanced Cordless Telecommunications (DECT); Transmission aspects 3,1 kHz telephony Interworking with other networks".
- 7) ETR 042: "Digital European Cordless Telecommunications (DECT); A Guide to DECT features that influence the traffic capacity and the maintenance of high radio link transmission quality, including the results of simulations".
- 8) ETR 043: "Digital European Cordless Telecommunications (DECT); Common interface; Services and facilities requirements specification".
- 9) ETR 056: "Digital European Cordless Telecommunications (DECT); System description document".

## History

Document history	
August 1996	First Edition
February 1997	Public Enquiry PE 9724: 1997-02-14 to 1997-06-13
November 1997	Vote V 9803: 1997-11-18 to 1998-01-16