



EUROPEAN
TELECOMMUNICATION
STANDARD

DRAFT
pr **ETS 300 497-3**

February 1997

Second Edition

Source: ETSI TC-RES

Reference: RE/DECT-040094-3

ICS: 33.020

Key words: ATS, DECT, GAP

**Radio Equipment and Systems (RES);
Digital Enhanced Cordless Telecommunications (DECT);
Common Interface (CI) Test Case Library (TCL);
Part 3: Abstract Test Suite (ATS) for Medium Access Control
(MAC) layer - Fixed radio Termination (FT)**

ETSI

European Telecommunications Standards Institute

ETSI Secretariat

Postal address: F-06921 Sophia Antipolis CEDEX - FRANCE

Office address: 650 Route des Lucioles - Sophia Antipolis - Valbonne - FRANCE

X.400: c=fr, a=atlas, p=etsi, s=secretariat - **Internet:** secretariat@etsi.fr

Tel.: +33 4 92 94 42 00 - Fax: +33 4 93 65 47 16

Copyright Notification: No part may be reproduced except as authorized by written permission. The copyright and the foregoing restriction extend to reproduction in all media.

© European Telecommunications Standards Institute 1997. All rights reserved.

Contents

Foreword	5
1 Scope	7
2 Normative references	7
3 Definitions and abbreviations	9
3.1 Definitions	9
3.2 Abbreviations	9
4 Abstract Test Method (ATM)	10
4.1 Description of ATM	10
4.2 Test strategy	11
5 Untestable Test Purposes (TPs)	12
6 ATS Conventions (only applicable for PTC LT_TC)	12
6.1 Naming conventions	12
6.1.1 Declarations part	12
6.1.1.1 General	12
6.1.1.2 Test suite operations definition	13
6.1.1.3 Test suite parameter declarations	13
6.1.1.4 Test case selection expression definition	13
6.1.1.5 Test suite constant declarations	13
6.1.1.6 Test suite variable declarations	13
6.1.1.7 Test case variable declarations	13
6.1.1.8 Timer declarations	14
6.1.1.9 ASP type definitions	14
6.1.1.10 PDU type definitions	14
6.1.1.11 CM type definitions	14
6.1.1.12 Alias definitions	14
6.1.2 Constraints part	15
6.1.2.1 General	15
6.1.3 Dynamic part	15
6.1.3.1 General	15
6.1.3.2 Test Case identifier	15
6.1.3.3 Test step identifier	16
6.1.3.4 Default identifier	16
6.1.3.5 Label identifier	16
6.1.3.6 ATS abbreviations	16
6.2 Implementation conventions	17
6.2.1 Declaration part	17
6.2.2 Constraint part	17
6.2.3 Dynamic part	17
Annex A (normative): Abstract test suite (ATS), PTC LT_TC	18
A.1 The machine processable ATS (TTCN.MP)	18
A.2 The graphical ATS (TTCN.GR)	18
Annex B (normative): Specification of PTC LT_MAC	19
B.1 General requirements	19
B.2 Additional requirements	19

Annex C (normative):	Partial PIXIT proforma for DECT MAC	20
C.1	Identification summary.....	20
C.2	ATS summary.....	20
C.3	Test laboratory.....	20
C.4	Client identification.....	20
C.5	SUT.....	21
C.6	Protocol layer information	21
C.6.1	Protocol identification	21
C.6.2	IUT information.....	21
Annex D (normative):	Protocol Conformance Test Report (PCTR) Proforma For DECT MAC.....	23
D.1	Identification summary.....	23
D.1.1	Protocol conformance test report.....	23
D.1.2	IUT identification.....	23
D.1.3	Testing environment.....	23
D.1.4	Limits and reservation	24
D.1.5	Comments.....	24
D.2	IUT Conformance status.....	24
D.3	Static conformance summary	24
D.4	Dynamic conformance summary	25
D.5	Static conformance review report	25
D.6	Test campaign report.....	26
D.7	Observations.....	26
Annex E (informative):	Bibliography	27
History	28

Foreword

This draft second edition European Telecommunication Standard (ETS) has been produced by the Digital Enhanced Cordless Telecommunications (DECT) Project of the European Telecommunications Standards Institute (ETSI), and is now submitted for the Public Enquiry phase of the ETSI standards approval procedure.

This ETS comprises nine parts, as follows:

- Part 1: "Test Suite Structure (TSS) and Test Purposes (TP) for Medium Access Control (MAC) layer".
- Part 2: "Abstract Test Suite (ATS) for Medium Access Control (MAC) layer - Portable radio Termination (PT)".
- Part 3: "Abstract Test Suite (ATS) for Medium Access Control (MAC) layer - Fixed radio Termination (FT)".**
- Part 4: "Test Suite Structure (TSS) and Test Purposes (TP) - Data Link Control (DLC) layer".
- Part 5: "Abstract Test Suite (ATS) - Data Link Control (DLC) layer".
- Part 6: "Test Suite Structure (TSS) and Test Purposes (TP) - Network (NWK) layer - Portable radio Termination (PT)".
- Part 7: "Abstract Test Suite (ATS) for Network (NWK) layer - Portable radio Termination (PT)".
- Part 8: "Test Suite Structure (TSS) and Test Purposes (TP) - Network (NWK) layer - Fixed radio Termination (FT)".
- Part 9: "Abstract Test Suite (ATS) for Network (NWK) layer - Fixed radio Termination (FT)".

Proposed transposition dates	
Date of latest announcement of this ETS (doa):	3 months after ETSI publication
Date of latest publication of new National Standard or endorsement of this ETS (dop/e):	6 months after doa
Date of withdrawal of any conflicting National Standard (dow):	6 months after doa

Blank page

1 Scope

This European Telecommunication Standard (ETS) contains the Abstract Test Suite (ATS) to test the DECT FP MAC layer.

The objective of this test specification is to provide a basis for approval tests for DECT equipment giving a high probability of air interface inter-operability between different manufacturer's DECT equipment. This part contains the ATS specification for testing of the MAC layer at the FT.

The ISO standard for the methodology of conformance testing (ISO/IEC 9646 Parts 1 to 7 [13] to [19]) as well as the ETSI rules for conformance testing (ETS 300 406 [10]) are used as basis for the test methodology.

Test specifications for the Physical Layer (PHL) are provided in other DECT standards.

Annex A provides the Tree and Tabular Combined Notation (TTCN) part of this ATS.

Annex B provides the specification of the parallel test component LT_MAC.

Annex C provides the Partial Protocol Implementation Extra Information for Testing (PIXIT) Proforma of this ATS.

Annex D provides the Protocol Conformance Test Report (PCTR) Proforma of this ATS.

2 Normative references

This ETS incorporates, by dated or undated reference, provisions from other publications. These normative references are cited at the appropriate places in the text and the publications are listed hereafter. For dated references, subsequent amendments to or revisions of any of these publications apply to this ETS only when incorporated in it by amendment or revision. For undated references the latest edition of the publication referred to applies.

- [1] ETS 300 175-1: "Radio Equipment and Systems (RES); Digital European Cordless Telecommunications (DECT); Common Interface (CI); Part 1: Overview".
- [2] ETS 300 175-2: "Radio Equipment and Systems (RES); Digital Enhanced Cordless Telecommunications (DECT); Common Interface (CI); Part 2: Physical layer (PHL)".
- [3] ETS 300 175-3: "Radio Equipment and Systems (RES); Digital European Cordless Telecommunications (DECT); Common Interface (CI); Part 3: Medium Access Control (MAC) layer".
- [4] ETS 300 175-4: "Radio Equipment and Systems (RES); Digital European Cordless Telecommunications (DECT); Common Interface (CI); Part 4: Data Link Control (DLC) layer".
- [5] ETS 300 175-5: "Radio Equipment and Systems (RES); Digital European Cordless Telecommunications (DECT); Common Interface (CI); Part 5: Network (NWK) layer".
- [6] ETS 300 175-6: "Radio Equipment and Systems (RES); Digital European Cordless Telecommunications (DECT); Common Interface (CI); Part 6: Identities and addressing".
- [7] ETS 300 175-7: "Radio Equipment and Systems (RES); Digital European Cordless Telecommunications (DECT); Common Interface (CI); Part 7: Security features".

- [8] ETS 300 175-8: "Radio Equipment and Systems (RES); Digital European Cordless Telecommunications (DECT); Common Interface (CI); Part 8: Speech coding and transmission".
- [9] ETS 300 175-9: "Radio Equipment and Systems (RES); Digital European Cordless Telecommunications (DECT); Common Interface (CI); Part 9: Public Access Profile (PAP)".
- [10] ETS 300 406: "Methods for Testing and Specification (MTS); Protocol and profile conformance testing specifications; Standardization methodology".
- [11] ETS 300 474: "Radio Equipment and Systems (RES); Digital Enhanced Cordless Telecommunications (DECT); Generic Access Profile (GAP); Profile requirement list and profile specific Implementation Conformance Statement (ICS) proforma".
- [12] ETS 300 497-1: "Radio Equipment and Systems (RES); Digital Enhanced Cordless Telecommunications (DECT); Common Interface (CI) Test Case Library (TCL); Part 1: Test Suite Structure (TSS) and Test Purposes (TP) for Medium Access Control (MAC) layer".
- [13] ISO/IEC 9646-1 (1991): "Information technology - Open Systems Interconnection - Conformance testing methodology and framework - Part 1: General concepts". (See also CCITT Recommendation X.290 (1991)).
- [14] ISO/IEC 9646-2 (1991): "Information technology - Open Systems Interconnection - Conformance testing methodology and framework - Part 2: Abstract test suite specification". (See also CCITT Recommendation X.291 (1991)).
- [15] ISO/IEC 9646-3 (1991): "Information technology - Open Systems Interconnection - Conformance testing methodology and framework - Part 3: The tree and tabular combined notation". (See also CCITT Recommendation X.292 (1992)).
- [16] ISO/IEC 9646-4 (1991): "Information technology - Open Systems Interconnection - Conformance testing methodology and framework - Part 4: Test realisation". (See also CCITT Recommendation X.292 (1992)).
- [17] ISO/IEC 9646-5 (1991): "Information technology - Open Systems Interconnection - Conformance testing methodology and framework - Part 5: Requirements on test laboratories and clients for the conformance assessment process". (See also CCITT Recommendation X.292 (1992)).
- [18] ISO/IEC 9646-6 (1991): "Information technology - Open Systems Interconnection - Conformance testing methodology and framework - Part 6: Protocol profile test specification".
- [19] ISO/IEC 9646-7 (1991): "Information technology - Open Systems Interconnection - Conformance testing methodology and framework - Part 7: Implementation conformance statement".
- [20] 91/263/EEC: "Council Directive of 29 April 1991 on the approximation of the laws of the Member States concerning telecommunications terminal equipment, including the mutual recognition of their conformity" (Terminal Directive).
- [21] TBR 6: "Radio Equipment and Systems (RES); Digital Enhanced Cordless Telecommunications (DECT); General terminal attachment requirements".
- [22] TBR 10: "Radio Equipment and Systems (RES); Digital Enhanced Cordless Telecommunications (DECT); General terminal attachment requirements; Telephony applications".

- [23] TBR 11 (1992): "Radio Equipment and Systems (RES); Attachment requirements for terminal equipment for Digital European Cordless Telecommunications (DECT) Public Access Profile (PAP) applications".
- [24] TBR 22: "Radio Equipment and Systems (RES); Attachment requirements for terminal equipment for Digital Enhanced Cordless Telecommunications (DECT) Generic Access Profile (GAP) applications".

3 Definitions and abbreviations

3.1 Definitions

For the purposes of this ETS, the definitions given in ISO/IEC 9646-1 [13] and ETS 300 175-1 [1] apply.

3.2 Abbreviations

For the purposes of this ETS, the following abbreviations apply:

ASP	Abstract Service Primitive
ATM	Abstract Test Method
ATS	Abstract Test Suite
BI	Invalid Behaviour
BO	Inopportune Behaviour
BV	Valid Behaviour
CA	Capability tests
CC	Call Control
CI	Common Interface
CM	Co-ordination Message
CP	Co-ordination Point
DECT	Digital Enhanced Cordless Telecommunication
DLC	Data Link Control
FT	Fixed radio Termination
IUT	Implementation Under Test
LT	Lower Tester
MAC	Medium Access Control
MTC	Main Test Component
NWK	Network
PAP	Public Access Profile
PCO	Point of Control and Observation
PDU	Protocol Data Unit
PHL	Physical Layer
PICS	Protocol Implementation Conformance Statement
PIXIT	Protocol Implementation Extra Information for Testing
PT	Portable radio Termination
PTC	Parallel Test Component
SAP	Service Access Point
SARI	Secondary Access Rights Identity
SUT	System Under Test
TP	Test Purpose
TSS	Test Suite Structure
TTCN	Tree and Tabular Combined Notation
UT	Upper Tester

4 Abstract Test Method (ATM)

This clause describes the ATM used to test the DECT MAC layer protocol at the Fixed radio Termination (FT).

4.1 Description of ATM

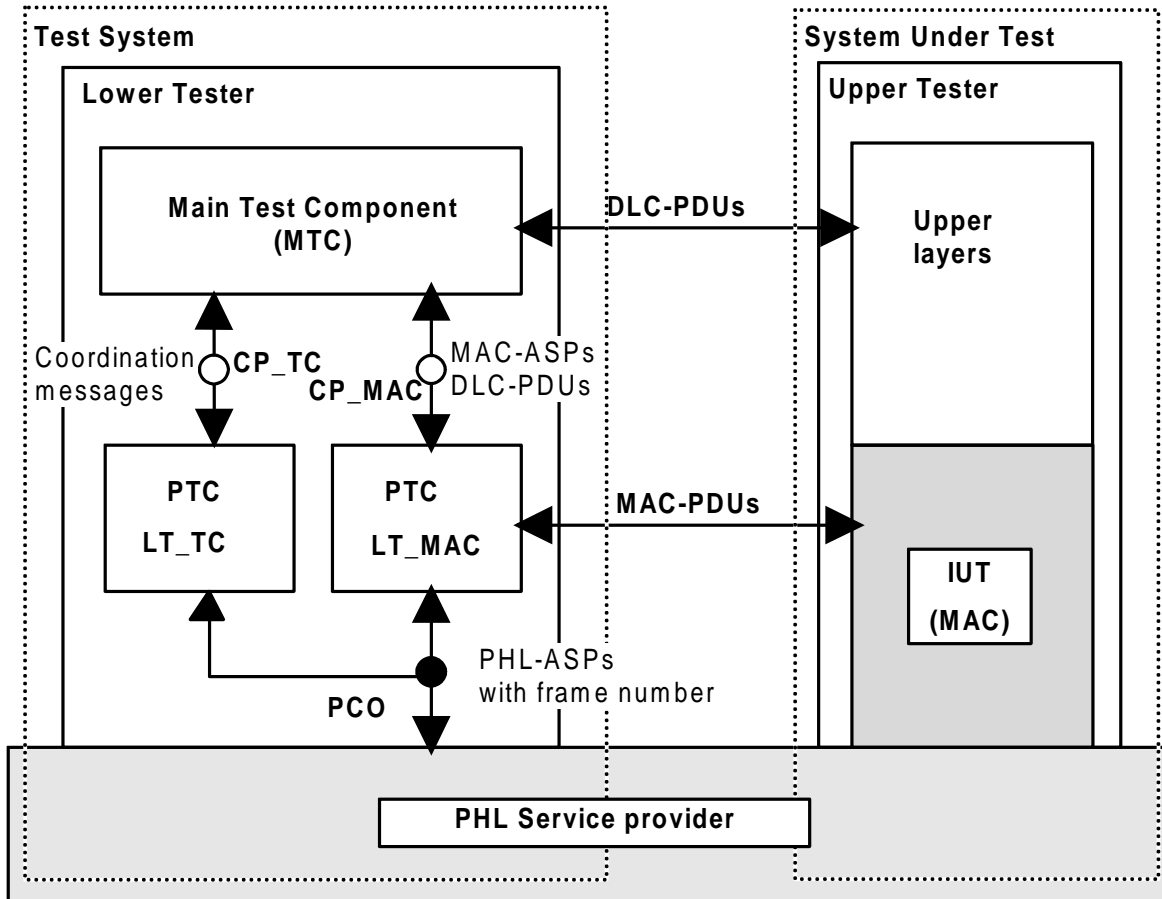

Figure 1: Remote test method, embedded variant

A single-party testing concept is used, which consists of the following abstract testing functions:

- PCO:** the Point of Control and Observation (PCO) for MAC Layer testing is located at the D-Service Access Point (D-SAP) between the MAC layer and the Physical layer. All test events at the PCO are specified in terms of Physical Layer Abstract Service Primitives (PHL-ASPs) (frame number parameter added).
- CP_TC:** Co-ordination Point Test Case (CP_TC) is located between the Main Test Component (MTC) and Parallel Test Component (PTC) LT_TC in the test system. It is used for passing co-ordination messages between these two testing functions.
- CP_MAC:** Co-ordination Point MAC (CP_MAC) is located between the MTC and PTC LT_MAC in the test system. It is equivalent to the PCO used for Data Link Control (DLC) layer testing in part 6 of this ETS. All co-ordination messages at this CP are specified in terms of MAC-ASPs and DLC Protocol Data Units (DLC-PDUs).

PTC LT_TC: the Lower Tester Parallel Test Component LT_TC (PTC LT_TC) is located in the test system. It makes restricted use of the PCO by only observing the test events in both directions. It assigns preliminary verdicts (the MTC assigns the final verdict).

NOTE: This restricted use of the PCO is a non-ISO/IEC 9646-2 [14] application of the PCO.

PTC LT_MAC: the Lower Tester Parallel Test Component LT_MAC (PTC LT_MAC) is located in the test system. It provides indirect control and observation of the Implementation Under Test (IUT) during test execution, via the underlying service-provider. It does not assign any verdicts.

MTC: the Main Test Component (MTC) is located in the test system. It is responsible for creating and terminating the PTCs, managing the co-ordination points CP_TC and CP_MAC, and computation of the final test case verdict.

Upper layers: no explicit Upper Tester (UT) exists in the test system. However, the System Under Test (SUT) (upper layers) needs to carry out some UT functions to achieve some effects of test co-ordination procedures.

The primitives used at the PCO (physical SAP - DSAP) are defined according to ETS 300 175-2 [2], clause 7 and associated subclauses.

The co-ordination messages used at CP_MAC co-ordination point are abstract primitives including protocol data units and frames. The abstract primitives (MAC ASPs) are defined according to ETS 300 175-3 [3], clause 8 and associated subclauses. Two abstract primitives for starting and stopping the synchronization between the main test component and the parallel test component LT_MAC are added for the needs of the tester. The protocol data units (DLC C-plane PDUs) are defined according to ETS 300 175-4 [4], clause 7 and associated subclauses. The frames (DLC U-plane frames) are defined according to ETS 300 175-4 [4], clause 12 and associated subclauses.

4.2 Test strategy

The ATM defined in subclause 4.1 requires the use of concurrent TTCN, which is specified in Amendment 1 of ISO/IEC 9646-3 [15]. The parallel test components PTC_TC and PTC_MAC is, however, seen as two independent entities. This means that there is no communication or synchronization between the two PTCs during the test.

PTC_TC is specified in TTCN (annex A). Since PTC_TC is only observing at the PCO, this ATS does not contain any send statements. Once the Test Purpose (TP) is fulfilled, the PTC_TC terminates, i.e. there are no postambles, unless required by the TP. No explicit co-ordination messages is exchanged at CP_TC. To simplify the TTCN test cases, the underlying service provider has been assigned the task of frame numbering. Consequently, a frame parameter has been added to some of the PHL-ASPs.

The requirements for PTC_MAC (annex B) are specified using ETS 300 474 [11].

The Main Test Component (MTC) creates the two PTCs (using CREATE operation), stimulates the PTC_MAC (using MAC ASPs at CP_MAC) and then waits for the two PTCs to terminate (using the DONE event). The final verdict is computed as follows:

- a PASS is assigned if PTC_TC returns a PASS verdict and the expected event is received from PTC_MAC at CP_MAC;
- a FAIL verdict is assigned if PTC_TC returns a FAIL verdict independently of what is received from PTC_MAC at CP_MAC;
- an INCONC verdict is assigned if PTC_TC returns an INCONC verdict and the expected event is received from PTC_MAC at CP_MAC; or returns a PASS verdict and an unexpected event is received from PTC_MAC at CP_MAC.

5 Untestable Test Purposes (TPs)

This clause gives a list of TPs which are not implemented in the ATS for PTC LT_TC (annex A) due to the chosen abstract test method or other restrictions.

Table 1: Untestable TPs

Test purpose	Reason
TP/PG/BV-00	No procedure can be defined to verify that the FT manages correctly the paging Extended Flag when it transmit pages.
TP/DT/CA-03	There is no reason for an IUT to start the procedure to switch from clear to encrypted mode by itself when a basic bearer is established.
TP/DT/CA-04	There is no reason for an IUT to start the procedure to switch from clear to encrypted mode by itself when a basic bearer is established and vice versa.
TP/BH/BV-00	There is no reason for an IUT to start the procedure to switch from clear to encrypted mode by itself when a basic bearer is established and vice versa.
TP/BH/BV-01	There is no reason for an IUT to start the procedure to switch from clear to encrypted mode by itself when a basic bearer is established and vice versa.
TP/DT/BV-00	There is no reason for an IUT to start the procedure to switch from clear to encrypted mode by itself when a basic bearer is established and vice versa.
TP/DT/BV-01	There is no reason for an IUT to start the procedure to switch from clear to encrypted mode by itself when a basic bearer is established and vice versa.

6 ATS Conventions (only applicable for PTC LT_TC)

The ATS conventions are intended to give a better understanding of the ATS but they also describe the conventions made for the development of the ATS. These conventions shall be considered during any later maintenance or further development of the ATS.

The ATS conventions contain two clauses, the naming conventions and the implementation conventions. The naming conventions describe the structure of the naming of all ATS elements. The implementation conventions describe the functional structure of the ATS.

To define the ATS, the guidelines of the documents ETS 300 406 [10] and ETR 141 were considered.

6.1 Naming conventions

6.1.1 Declarations part

This subclause describes the naming conventions chosen for the elements of the ATS declarations part.

6.1.1.1 General

The following general rules apply for name giving in the declarations part. All type definitions (Simple type definitions, Structured type definitions, ASP type definitions and PDU type definitions) shall be written in uppercase.

All element names (Structured type definition), parameter names (ASP type definition) and field names (PDU type definition) shall be written in lowercase.

Predefined types (e.g. BITSTRING[8]) are never used in structured type definitions, ASP type definitions or PDU type definitions. Simple types are used instead.

All declarations in the test suite are listed in alphabetical order. A different order of listing should be used for only maintenance reason.

6.1.1.2 Test suite operations definition

The test suite operation identifiers are composed of substrings in lowercase letters, except for standard prefix "TSO_". Each substring is separated by an underscore character ("_").

EXAMPLE: TSO_substring.

6.1.1.3 Test suite parameter declarations

The test suite parameter identifiers are composed of substrings in lowercase letters, except for the standard prefix "TSP_". Each substring is separated by an underscore character ("_").

EXAMPLE 1: TSP_t_wait

If the test suite parameter references a Protocol Implementation Conformance Statement (PICS) item, the letter "C" is added to the standard prefix.

EXAMPLE 2: TSPC_extended_rf_carriers

If the test suite parameter references a PIXIT item, the letter "X" is added to the standard prefix.

EXAMPLE 3: TSPX_pmid

Complete names as defined in the specifications are used.

6.1.1.4 Test case selection expression definition

The test case selection expression identifiers are composed of substrings in lowercase letters, beginning with the prefix "TCS_". Each substring is separated by an underscore character ("_").

6.1.1.5 Test suite constant declarations

The test suite constant identifiers are composed of substrings in lowercase letters, except for the prefix "TSC_". Each substring is separated by an underscore character ("_").

If the test suite constant represents a system parameter, the complete name defined in the protocol standard is used.

EXAMPLE: TSC_n200

6.1.1.6 Test suite variable declarations

The test suite variable identifiers are composed of substrings in lowercase letters, except for the prefix "TSV_". Each substring is separated by an underscore character ("_").

Complete names as defined in the protocol standard are used.

6.1.1.7 Test case variable declarations

The test case variable identifiers are composed of substrings in lowercase letters, except for the prefix "TCV_". Each substring is separated by an underscore character ("_").

Complete names as defined in the protocol standard are used.

6.1.1.8 Timer declarations

Two type of timers can be identified:

1) standardized:

those defined in the protocol standard, e.g. T201. They use exactly the same name as in the standard;

As there is a tolerance margin accepted for these timers, three values are needed:

- the maximum value allowed, which will use the suffix "_max";
- the minimum value allowed, which will use the suffix "_min";
- the value actually implemented, with no suffix;

EXAMPLE 1: T201_max, T201_min, and T201;

2) not standardized:

those not defined in the protocol standard, i.e. for execution use, e.g. a timer waiting for a response. These timers begin with the prefix "T_", followed by a string in lowercase letters;

EXAMPLE 2: T_resp represents a timer for controlling the response time of the IUT.

6.1.1.9 ASP type definitions

The general conventions in subclause 6.1.1.1 applies.

The identifier of an ASP type uses the same name as the name defined in the protocol standard.

EXAMPLE: PL_TX_REQ for an ASP containing a MAC layer PDU to the peer MAC layer (the IUT).

6.1.1.10 PDU type definitions

The general conventions in subclause 6.1.1.1 applies.

The PDU type identifier shall identify the related structure or type as defined in the protocol standard.

EXAMPLE: A_MT_BASIC_CONNECTION_CONTROL.

6.1.1.11 CM type definitions

The CM types are copied from the ASP types in Part 5 of this ETS without modifications.

6.1.1.12 Alias definitions

Alias definitions are not used.

6.1.3.3 Test step identifier

The test step identifier is built of substrings in lowercase letters, preceded by a string of uppercase letters. The substrings are joined by underscore characters. The first substring indicates the main function of the Test Step; e.g. PR for preamble, PO for postamble, LTS for local tree and STP for general test step. The remaining substrings indicates the purpose of the step.

EXAMPLE: PO_release_bearer.

6.1.3.4 Default identifier

The default identifiers begin with the prefix "DF_", followed by a string in lowercase letters.

6.1.3.5 Label identifier

The identifiers in the label column is built according to table 3:

Table 3: Naming convention for verdict assignment identifier

Identifier:	<Table><nn>		
	<Table> = type of table	TB	Test Body
		CS	Check State test step
		DF	DeFault
		PO	POstamble
		PR	PReamble
		TS	TestStep
	<nn> = sequential number	(00-99)	Label number

6.1.3.6 ATS abbreviations

These abbreviations are used to shorten identifier names:

- addr address
- ack acknowledgement
- bear bearer
- cap capability
- cfm confirm
- chn channel
- con connection
- ctrl control
- est establish
- ext extension
- id identification
- ind indication
- info information
- max maximum
- min minimum
- par parameter
- prop proprietary
- rel release
- req request
- rsp response
- std standard
- sys system

6.2 Implementation conventions

6.2.1 Declaration part

The comment line of single element TTCN tables (e.g. test suite constants) is used to give a reference where the format and content of the element is described in the relevant protocol standards. Any particularity of the element format or content is described in the comment line.

The comment line in the header of multi element TTCN tables (e.g. ASPs) is used to reference to the protocol standard.

The detailed comments are used to describe any particularity of the table.

In the ASP, PDU, and CM declarations, the comments column is used to identify if a parameter (in ASPs) or field (in PDUs) is mandatory or optional:

- M: mandatory;
- O: optional.

In the ASP and PDU declarations the comments column is further used to give information about the parameter/field value, in particular if the parameter/field contains a fixed spare value.

6.2.2 Constraint part

The ASPs and PDUs are defined in a way that all relevant parameters/fields are parametrized. That improves the transparency of the constraints in the dynamic part, as all values which are relevant for the test are always present.

Generally no modified constraints are used. This allows an easier reuse and adaptation of constraints if they are reused in other test specifications.

The Comment line of a constraint always contains a reference to the relevant protocol standard.

The detailed comments footer is used to describe any particularity of the table.

6.2.3 Dynamic part

All events which are defined as a conformance requirement by the TP, causes a preliminary verdict PASS if the requirement is met.

All invalid events are handled in the default tree. Only FAIL or INCONC verdicts are assigned in the default tree.

The preamble, the test body and the postamble have different defaults, which allows a specific verdict handling, e.g. only INCONC verdicts are assigned in the preamble.

Except for local trees, test steps do not contain a default. Then there is no restrictions regarding the error handling.

All verdict assignments are labelled. According to ISO/IEC 9646-3 [15], annex E, clause E.2, labels should be written to the conformance log. This allows, for example, to identify where the test failed. To allow an exact identification of the table in which the verdict was assigned, the convention described in subclause 6.1.3.5 is applied.

To avoid deadlocks, the Parallel Test Components (PTC) LT_TC and LT_MAC shall always terminate.

TPs which are listed in the untestable TP list in clause 5 are not considered in the ATS, thus these TC identifiers are missing in the ATS and the numbering of the TCs is not always continuous.

Annex A (normative): Abstract test suite (ATS), PTC LT_TC

The ATS is written in TTCN according to ISO/IEC 9646-3 [15].

As the ATS was developed on a separate TTCN tool the TTCN tables are not completely referenced in the contents table. The ATS itself contains a Test Suite Overview part which provides additional information and references about the ATS.

NOTE: According to ISO/IEC 9646-3 [15], in case of a conflict in interpretation of the operational semantics of TTCN.GR and TTCN.MP, the operational semantics of the TTCN.GR representation takes precedence.

A.1 The machine processable ATS (TTCN.MP)

The electronic form of the machine processable file (TTCN MP format) corresponding to this ATS is contained in an ASCII text file (DEP04973.MP (note)) associated with this ETS.

NOTE: This file is located in a compressed archive file named 4973_EP.LZH. Other file formats are available on request.

A.2 The graphical ATS (TTCN.GR)

The electronic form of the graphical ATS (TTCN GR format) corresponding to this ATS is contained in an ASCII Postscript file (DEP04973.PS (note)) associated with this ETS.

NOTE: This file is located in a compressed archive file named 4973_EP.LZH. Other file formats are available on request.

Annex B (normative): Specification of PTC LT_MAC

B.1 General requirements

The PTC LT_MAC (MAC emulation) shall, as a minimum, fulfil all requirements with profile status M in the profile Requirement List (profile RL) in ETS 300 474 [11], clause 7.

B.2 Additional requirements

A number of commands have been defined to control the behaviour of PTC LT_MAC (the MAC emulation). In the annex A, these are implemented as a co-ordination message with a parameter to specify the required action. The test system shall support the actions specified in table B.1.

Table B.1: Actions to be supported by the test system

Action	Ref. to ETS 300 175-3 [3]	Requirement
TSC_action2	6.2.5.1	Generate A field CRC error in NT message.
TSC_action3	ETS 300 175-2 2]: 4.8	Corrupt the Z-field in the next transmitted burst.
TSC_action4	11.5.1	Generate an incorrect message for RFPI handshake. Change the RFPI transmitted by the Lower Tester on all traffic bearers to the IUT by inverting bit a47.
TSC_action5	10.8.1.1	Do not acknowledge until CS segment have been received three times.
TSC_action17	10.5.1 - 10.6.2	Initiate and perform an intracell bearer handover procedure.
TSC_action18	10.5.1 - 10.6.2	Initiate and perform an intercell bearer handover procedure.
TSC_start	11.3.2	Start test case synchronization.
TSC_stop	11.5.1	Stop test case synchronization.

NOTE: These actions are defined as Test Suite Constants in the ATS (annex A).

Annex C (normative): Partial PIXIT proforma for DECT MAC

Notwithstanding the provisions of the copyright clause related to the text of this ETS, ETSI grants that users of this ETS may freely reproduce the PIXIT proforma in this annex so that it can be used for its intended purposes and may further publish the completed PIXIT.

The PIXIT Proforma is based on ISO/IEC 9646-6 [18]. Any additional information needed can be found in this international standard document.

C.1 Identification summary

Table C.1

PIXIT Number:	
Test Laboratory Name:	
Date of Issue:	
Issued to:	

C.2 ATS summary

Table C.2

Protocol Specification:	ETS 300 175-3
Protocol to be tested:	
ATS Specification:	ETS 300 497-3
Abstract Test Method:	ETS 300 497-3 clause 4

C.3 Test laboratory

Table C.3

Test Laboratory Identification:	
Test Laboratory Manager:	
Means of Testing:	
SAP Address:	

C.4 Client identification

Table C.4

Client Identification:	
Client Test manager:	
Test Facilities required:	

C.5 SUT

Table C.5

Name:	
Version:	
SCS Number:	
Machine configuration:	
Operating System Identification:	
IUT Identification:	
PICS Reference for IUT:	
Limitations of the SUT:	
Environmental Conditions:	

C.6 Protocol layer information

C.6.1 Protocol identification

Table C.6

Name:	DECT - Medium Access Control Layer ETS 300 175-3 FT part
Version:	
PICS References:	

C.6.2 IUT information

Table C.7: Addresses

Item	Parameter	Parameter Type	Explanation	Value
1	TSPX_pmid	B_20 - (Bitstring[20])	PMID for RFP	
2	TSPX_rfpi1	B_40 - (Bitstring[40])	RFPI for RFP number 1 (ETS 300 175-6 [6])	
3	TSPX_rfpi2	B_40 - (Bitstring[40])	RFPI for RFP number 2 (ETS 300 175-6 [6])	

Table C.8: Timer values

Item	Parameter	Parameter Type	Explanation	Value
1	TSPX_t_implicit_send	INT_0_99 - INTEGER (0..99)	Max. time to wait after request for invocation of an implicit send event (In second).	

Table C.9: Procedural information

Item	Parameter	Parameter Type	Explanation	Value
1	TSPX_blind_slot	BOOLEAN	TRUE for IUT that have blind slot.	TRUE FALSE
4	TSPX_extended_rf	BOOLEAN	Does the IUT support extended RF carrier.	TRUE FALSE
5	TSPX_sari	BOOLEAN	Does the IUT support Secondary Access Rights Identity (SARI) list.	TRUE FALSE
6	TSPX_intercell_handover	BOOLEAN	Does the IUT support intercell handover.	TRUE FALSE
7	TSPX_intracell_handover	BOOLEAN	Does the IUT support intracell handover.	TRUE FALSE
9	TSPX_bearer_handover	BOOLEAN	Does the IUT support bearer handover withing the whole FT?	TRUE FALSE

Table C.10: Implicit send events

Item	PIXIT (see Note)	Parameter Type	Indication how the implicit send event can be invoked
1	TSPX_invoke_short_page	Implicit Send	Indicate in the following lines the procedure to force the IUT to transmit a paging message in short page format.
2	TSPX_invoke_zero_page	Implicit Send	Indicate in the following lines the procedure to force the IUT to transmit a paging message in zero page format.
3	TSPX_invoke_sari_message	Implicit Send	Indicate in the following lines the procedure to force the IUT to transmit the NT message with E bit set (A SARI is introduced).

NOTE: The PIXIT names are related to the test steps where the Implicit send events are handled, e.g. the PIXIT TSPX_invoke_abnormal_release is related to the test step STP_invoke_abnormal_release.

Annex D (normative): Protocol Conformance Test Report (PCTR) Proforma For DECT MAC

Notwithstanding the provisions of the copyright clause related to the text of this ETS, ETSI grants that users of this ETS may freely reproduce the PCTR proforma in this annex so that it can be used for its intended purposes and may further publish the completed PCTR.

The PCTR Proforma is based on ISO/IEC 9646-6 [18]. Any additional information needed can be found in this international standard document.

D.1 Identification summary

D.1.1 Protocol conformance test report

Table D.1

PCTR Number:	
PCTR Date:	
Corresponding SCTR Number:	
Corresponding SCTR Date:	
Test Laboratory Identification:	
Test Laboratory Manager:	
Signature:	

D.1.2 IUT identification

Table D.2

Name:	
Version:	
Protocol specification:	
PICS:	
Previous PCTR if any:	

D.1.3 Testing environment

Table D.3

PIXIT Number:	
ATS Specification:	ETS 300 497-3
Abstract Test Method:	ETS 300 497-3 clause 4
Means of Testing identification:	
Date of testing:	
Conformance Log reference(s):	
Retention Date for Log reference(s):	

D.1.4 Limits and reservation

Additional information relevant to the technical contents or further use of the test report, or the rights and obligations of the test laboratory and the client, may be given here. Such information may include restriction on the publication of the report.

.....
.....
.....
.....
.....
.....

D.1.5 Comments

Additional comments may be given by either the client or the test laboratory on any of the contents of the PCTR, for example, to note disagreement between the two parties.

.....
.....
.....
.....
.....
.....

D.2 IUT Conformance status

This IUT has or has not been shown by conformance assessment to be non conforming to the specified protocol specification.

Strike the appropriate words in this sentence. If the PICS for this IUT is consistent with the static conformance requirements (as specified in clause 3 in this report) and there are no "FAIL" verdicts to be recorded (in clause 6) strike the words "has or". otherwise strike the words "or has not".

D.3 Static conformance summary

The PICS for this IUT is or is not consistent with the static conformance requirements in the specified protocol.

Strike the appropriate words in this sentence.

D.4 Dynamic conformance summary

The test campaign did or did not reveal errors in the IUT.

Strike the appropriate words in this sentence. If there are no "FAIL" verdicts to be recorded (in clause 6 of this report) strike the words "did or". otherwise strike the words "or did not".

Summary of the results of groups of test:

.....
.....
.....
.....
.....
.....

D.5 Static conformance review report

If clause 3 indicates non-conformance, this subclause itemises the mismatches between the PICS and the static conformance requirements of the specified protocol specification.

.....
.....
.....
.....
.....

D.6 Test campaign report

Table D.4

ATS Reference	Selected?	Run?	Verdict	Observations (Reference to any observations made in clause 7)
TC_FT_BH_CA_00	Yes/No	Yes/No		
TC_FT_BH_CA_01	Yes/No	Yes/No		
TC_FT_BR_CA_00	Yes/No	Yes/No		
TC_FT_BS_BV_00	Yes/No	Yes/No		
TC_FT_BS_CA_00	Yes/No	Yes/No		
TC_FT_DB_BV_03	Yes/No	Yes/No		
TC_FT_DB_CA_00	Yes/No	Yes/No		
TC_FT_DB_CA_01	Yes/No	Yes/No		
TC_FT_DB_CA_02	Yes/No	Yes/No		
TC_FT_DB_CA_03	Yes/No	Yes/No		
TC_FT_DB_CA_04	Yes/No	Yes/No		
TC_FT_DB_CA_05	Yes/No	Yes/No		
TC_FT_DB_CA_06	Yes/No	Yes/No		
TC_FT_DB_CA_07	Yes/No	Yes/No		
TC_FT_DT_BI_00	Yes/No	Yes/No		
TC_FT_DT_BI_01	Yes/No	Yes/No		
TC_FT_DT_CA_00	Yes/No	Yes/No		
TC_FT_DT_CA_01	Yes/No	Yes/No		
TC_FT_DT_CA_02	Yes/No	Yes/No		
TC_FT_LM_CA_05	Yes/No	Yes/No		
TC_FT_PG_BV_01	Yes/No	Yes/No		
TC_FT_PG_CA_00	Yes/No	Yes/No		
TC_FT_PG_CA_01	Yes/No	Yes/No		

D.7 Observations

Additional information relevant to the technical content of the PCTR are given here.

.....

.....

.....

.....

.....

.....

Annex E (informative): Bibliography

The following references are provided for information.

- 1) EWOS/ETSI Project Team No 5: "Project Report and Technical Report. OSI Conformance Testing Methodology and Procedures in Europe".
- 2) ETR 022: "Advanced Testing Methods (ATM); Vocabulary of terms used in communications protocols conformance testing".
- 3) ETR 141: "Methods for Testing and Specification (MTS); Protocol and profile conformance testing specifications; The Tree and Tabular Combined Notation (TTCN) style guide".
- 4) CEPT Recommendation T/SGT SF2 (89) 6/0: "Draft Recommendation T/SF Services and Facilities of Digital Enhanced Cordless Telecommunications".
- 5) ETR 015: "Radio Equipment and Systems (RES); Digital Enhanced Cordless Telecommunications (DECT); Reference document".
- 6) ETR 041: "Transmission and Multiplexing (TM); Digital Enhanced Cordless Telecommunications (DECT); Transmission aspects 3,1 kHz telephony Interworking with other networks".
- 7) ETR 042: "Radio Equipment and Systems (RES); Digital Enhanced Cordless Telecommunications (DECT); A Guide to DECT features that influence the traffic capacity and the maintenance of high radio link transmission quality, including the results of simulations".
- 8) ETR 043: "Radio Equipment and Systems (RES); Digital Enhanced Cordless Telecommunications (DECT); Common interface; Services and Facilities requirements specification".
- 9) ETR 056: "Radio Equipment and Systems (RES); Digital Enhanced Cordless Telecommunications (DECT); System description document".

History

Document history	
August 1996	First Edition
February 1997	Public Enquiry PE 9724: 1997-02-14 to 1997-06-13