

**E**UROPEAN  
**T**ELECOMMUNICATION  
**S**TANDARD

**DRAFT**  
pr **ETS 300 497-1**

February 1997

**Second Edition**

---

Source: ETSI EP-DECT

Reference: RE/DECT-040094-1

ICS: 33.020

**Key words:** DECT, TCL, MAC

**Radio Equipment and Systems (RES);  
Digital Enhanced Cordless Telecommunications (DECT);  
Common Interface (CI) Test Case Library (TCL);  
Part 1: Test Suite Structure (TSS) and Test Purposes (TP) for  
Medium Access Control (MAC) layer**

**ETSI**

European Telecommunications Standards Institute

**ETSI Secretariat**

**Postal address:** F-06921 Sophia Antipolis CEDEX - FRANCE

**Office address:** 650 Route des Lucioles - Sophia Antipolis - Valbonne - FRANCE

**X.400:** c=fr, a=atlas, p=etsi, s=secretariat - **Internet:** secretariat@etsi.fr

Tel.: +33 4 92 94 42 00 - Fax: +33 4 93 65 47 16

---

**Copyright Notification:** No part may be reproduced except as authorized by written permission. The copyright and the foregoing restriction extend to reproduction in all media.

© European Telecommunications Standards Institute 1997. All rights reserved.



## Contents

Foreword .....	5
1 Scope .....	7
2 Normative references .....	7
3 Definitions and abbreviations .....	8
3.1 Definitions .....	8
3.2 Abbreviations .....	11
4 Test suite structure .....	12
4.1 Overview .....	12
4.2 TSS .....	13
4.3 Test groups .....	13
4.3.1 Protocol groups .....	13
4.3.1.1 Broadcast services .....	14
4.3.1.2 Connectionless services .....	14
4.3.1.3 Connection oriented services .....	14
4.3.1.4 Layer management procedures .....	14
4.3.1.5 Test messages procedures .....	14
4.3.2 Main test groups .....	14
4.3.2.1 Capability (CA) tests .....	14
4.3.2.2 Valid Behaviour (BV) tests .....	14
4.3.2.3 Invalid Behaviour (BI) tests .....	14
5 Test Purposes (TP) .....	15
5.1 Introduction .....	15
5.1.1 TP definition conventions .....	15
5.1.2 TP naming conventions .....	15
5.1.3 Sources of TP definitions .....	15
5.2 Broadcast services .....	15
5.2.1 Downlink broadcast .....	15
5.2.1.1 CA tests .....	16
5.2.1.2 BV tests .....	17
5.2.2 Paging services .....	17
5.2.2.1 CA tests .....	17
5.2.2.2 BV tests .....	18
5.2.3 Non-continuous broadcast services .....	18
5.2.3.1 CA tests .....	18
5.2.3.2 BV tests .....	18
5.3 Connectionless services .....	18
5.3.1 Downlink connectionless services .....	18
5.3.1.1 CA tests .....	18
5.3.1.2 BV tests .....	18
5.3.2 Uplink connectionless services .....	18
5.3.2.1 CA tests .....	18
5.3.2.2 BV tests .....	18
5.4 Connection oriented services .....	19
5.4.1 Bearer setup .....	19
5.4.1.1 CA tests .....	19
5.4.1.2 BV tests .....	19
5.4.2 Connection modification .....	19
5.4.2.1 CA tests .....	19
5.4.3 Bearer handover .....	19
5.4.3.1 CA tests .....	20
5.4.3.2 BV tests .....	20
5.4.4 Bearer release .....	21

	5.4.4.1	CA tests.....	21
	5.4.4.2	BV tests.....	21
5.4.5	Data transfer .....		21
	5.4.5.1	CA tests.....	22
	5.4.5.2	BV tests.....	22
	5.4.5.3	BI tests .....	23
5.5	Layer management procedures .....		23
	5.5.1	CA tests .....	24
	5.5.2	BV tests .....	24
5.6	Test messages procedures.....		24
	5.6.1	CA tests .....	24
Annex A (informative):	Bibliography .....		25
History .....			26

## Foreword

This draft second edition European Telecommunication Standard (ETS) has been produced by the Digital Enhanced Cordless Telecommunications (DECT) Project of the European Telecommunications Standards Institute (ETSI), and is now submitted for the Public Enquiry phase of the ETSI standards approval procedure.

This ETS comprises nine parts, as follows:

- Part 1:** "Test Suite Structure (TSS) and Test Purposes (TP) for Medium Access Control (MAC) layer".
- Part 2: "Abstract Test Suite (ATS) for Medium Access Control (MAC) layer - Portable radio Termination (PT)".
- Part 3: "Abstract Test Suite (ATS) for Medium Access Control (MAC) layer - Fixed radio Termination (FT)".
- Part 4: "Test Suite Structure (TSS) and Test Purposes (TP) - Data Link Control (DLC) layer".
- Part 5: "Abstract Test Suite (ATS) - Data Link Control (DLC) layer".
- Part 6: "Test Suite Structure (TSS) and Test Purposes (TP) - Network (NWK) layer - Portable radio Termination (PT)".
- Part 7: "Abstract Test Suite (ATS) for Network (NWK) layer - Portable radio Termination (PT)".
- Part 8: "Test Suite Structure (TSS) and Test Purposes (TP) - Network (NWK) layer - Fixed radio Termination (FT)".
- Part 9: "Abstract Test Suite (ATS) for Network (NWK) layer - Fixed radio Termination (FT)".

<b>Proposed transposition dates</b>	
Date of latest announcement of this ETS (doa):	3 months after ETSI publication
Date of latest publication of new National Standard or endorsement of this ETS (dop/e):	6 months after doa
Date of withdrawal of any conflicting National Standard (dow):	6 months after doa

Blank page

## 1 Scope

This European Telecommunication Standard (ETS) contains the Test Suite Structure (TSS) and Test Purposes (TP) to test the Digital Enhanced Cordless Telecommunications (DECT) Medium Access Control (MAC) layer.

The objective of this test specification is to provide a basis for conformance tests for DECT equipment giving a high probability of air interface inter-operability between different manufacturer's DECT equipment.

The ISO standard for the methodology of conformance testing (ISO/IEC 9646-1 [10] and ISO/IEC 9646-2 [11]) as well as the ETSI rules for conformance testing (ETS 300 406 [9]) are used as a basis for the test methodology.

## 2 Normative references

This ETS incorporates, by dated or undated reference, provisions from other publications. These normative references are cited at the appropriate places in the text and the publications are listed hereafter. For dated references, subsequent amendments to or revisions of any of these publications apply to this ETS only when incorporated in it by amendment or revision. For undated references the latest edition of the publication referred to applies.

- [1] ETS 300 175-1: "Radio Equipment and Systems (RES); Digital European Cordless Telecommunications (DECT); Common Interface (CI); Part 1: Overview".
- [2] ETS 300 175-2: "Radio Equipment and Systems (RES); Digital Enhanced Cordless Telecommunications (DECT); Common Interface (CI); Part 2: Physical layer (PHL)".
- [3] ETS 300 175-3: "Radio Equipment and Systems (RES); Digital European Cordless Telecommunications (DECT); Common Interface (CI); Part 3: Medium Access Control (MAC) layer".
- [4] ETS 300 175-4: "Radio Equipment and Systems (RES); Digital European Cordless Telecommunications (DECT); Common Interface (CI); Part 4: Data Link Control (DLC) layer".
- [5] ETS 300 175-5: "Radio Equipment and Systems (RES); Digital European Cordless Telecommunications (DECT); Common Interface (CI); Part 5: Network (NWK) layer".
- [6] ETS 300 175-6: "Radio Equipment and Systems (RES); Digital European Cordless Telecommunications (DECT); Common Interface (CI); Part 6: Identities and addressing".
- [7] ETS 300 175-7: "Radio Equipment and Systems (RES); Digital European Cordless Telecommunications (DECT); Common Interface (CI); Part 7: Security features".
- [8] ETS 300 175-8: "Radio Equipment and Systems (RES); Digital European Cordless Telecommunications (DECT); Common Interface (CI); Part 8: Speech coding and transmission".
- [9] ETS 300 406: "Methods for Testing and Specification (MTS); Protocol and profile conformance testing specifications; Standardization methodology".
- [10] ISO/IEC 9646-1 (1991): "Information technology - Open Systems Interconnection - Conformance testing methodology and framework - Part 1: General concepts". (See also CCITT Recommendation X.290 (1991)).

- [11] ISO/IEC 9646-2 (1991): "Information technology - Open Systems Interconnection - Conformance testing methodology and framework - Part 2: Abstract test suite specification". (See also CCITT Recommendation X.291 (1991)).
- [12] ISO 7498: "Information Processing Systems - Open Systems Interconnection - Basic Reference model".
- [13] 91/263/EEC: "Council Directive of 29 April 1991 on the approximation of the laws of the Member States concerning telecommunications terminal equipment, including the mutual recognition of their conformity" (Terminal Directive).
- [14] TBR 6: "Radio Equipment and Systems (RES); Digital Enhanced Cordless Telecommunications (DECT); General terminal attachment requirements".
- [15] TBR 10: "Radio Equipment and Systems (RES); Digital Enhanced Cordless Telecommunications (DECT); General terminal attachment requirements; Telephony applications".
- [16] TBR 11 (1992): "Radio Equipment and Systems (RES); Attachment requirements for terminal equipment for Digital European Cordless Telecommunications (DECT) Public Access Profile (PAP) applications".
- [17] TBR 22: "Radio Equipment and Systems (RES); Attachment requirements for terminal equipment for Digital Enhanced Cordless Telecommunications (DECT) Generic Access Profile (GAP) applications".

### 3 Definitions and abbreviations

#### 3.1 Definitions

For the purposes of this ETS, the definitions given in ETS 300 175-1 [1] apply. In addition, the following definitions apply:

**bearer handover:** The internal handover process provided by the Medium Access Control (MAC) layer, whereby one MAC connection can modify its underlying bearers while maintaining the service provided to the Data Link Control (DLC) layer.

NOTE 1: Bearer handover is slot based.

**broadcast:** A simplex point-to-multipoint mode of transmission.

NOTE 2: The transmitter may disregard the presence or absence of receivers.

**cell:** The domain served by a single antenna(e) system (including a leaky feeder) of one fixed part.

NOTE 3: A cell may include more than one source of radiated Radio Frequency (RF) energy (i.e. more than one radio end point).

**connection handover:** The internal handover process provided by the DLC layer, whereby one set of DLC entities (C-plane and U-plane) can re-route data from one MAC connection to a second new MAC connection, while maintaining the service provided to the network layer.

NOTE 4: Connection handover is DLC frame based.



**Connectionless mode (C/L):** A transmission mode that transfers one packet (one self contained unit) of data from one source point to one (or more) destination points in a single phase.

NOTE 5: Connectionless transmissions require the peer-to-peer associations to be pre-arranged, and the transmission is unacknowledged at that layer.

**Connection Oriented mode (C/O):** A transmission mode that transfers data from one source point to one or more destination points using a protocol based on three phases, "setup", "data transfer" and "release".

NOTE 6: Connection oriented mode requires no prearranged associations between peer entities (unlike C/L mode).

**double simplex bearer:** The use of two simplex bearers operating in the same direction on two physical channels. These pairs of channels always use the same RF carrier and always use evenly spaced slots (i.e. separated by 0,5 Time Division Multiple Access (TDMA) frame).

NOTE 7: A double-simplex bearer only exists as part of a multibearer MAC connection.

**duplex bearer:** The use of two simplex bearers operating in opposite directions on two physical channels. These pairs of channels always use the same RF carrier and always use evenly spaced slots (i.e. separated by 0,5 TDMA frame).

**field:** A continuous region of data (i.e. adjacent bits) that jointly convey information. Typically, a message will contain several fields. If data is not continuous then it is defined as two (or more) fields.

**Fixed Part (DECT Fixed Part) (FP):** A physical grouping that contains all the elements in the DECT network between the Local Network (LNW) and the DECT air interface.

NOTE 8: A DECT FP contains the logical elements of at least one FT, plus additional implementation specific elements.

**Fixed radio Termination (FT):** A logical group of functions that contains all the DECT processes and procedures on the fixed side of the DECT air interface.

NOTE 9: A FT only includes elements that are defined in the DECT Common Interface (CI) ETS. This includes radio transmission elements (layer 1) together with a selection of layer 2 and layer 3 elements.

**full slot (slot):** One 24th of a TDMA frame which is used to support one physical channel.

**half slot:** One 48th of a TDMA frame which is used to support one physical channel.

**Implementation Under Test (IUT):** See ISO/IEC 9646-1 [10];

**inter-cell handover:** The switching of a call in progress from one cell to another cell.

**logical channel:** A generic term for any distinct data path. Logical channels can be considered to operate between logical end points.

**Lower Layer Management Entity (LLME):** A management entity that spans a number of lower layers, and is used to describe all control activities which do not follow the rules of layering.

NOTE 10: In DECT, the LLME spans the network layer, the DLC layer, the MAC layer and the physical layer.

**MAC bearer (bearer):** MAC bearers are the service elements that are provided by each Cell Site Function (CSF). Each MAC bearer corresponds to a single service instance to the physical layer. See also simplex bearer, duplex bearer and double simplex bearer.

**MAC connection (connection):** An association between one source MAC Multi-Bearer Control (MBC) entity and one destination MAC MBC entity. This provides a set of related MAC services (a set of logical channels), and it can involve one or more underlying MAC bearers.

**multiframe:** A repeating sequence of 16 successive TDMA frames, that allows low rate or sporadic information to be multiplexed (e.g. basic system information or paging).

**paging:** The process of broadcasting a message from a DECT fixed part to one or more DECT portable parts.

NOTE 11: Different types of paging message are possible. e.g., the {REQUEST PAGING} message orders the recipient to respond with a call setup attempt.

**phase:** One discrete part of a procedure, where the start and end of the part can be clearly identified (e.g. by the arrival or dispatch of a primitive).

**physical channel (channel):** The simplex channel that is created by transmitting in one particular slot, on one particular RF channel, in successive TDMA frames (see also simplex bearer).

NOTE 12: One physical channel provides a simplex service. Two physical channels are required to provide a duplex service.

**Physical Layer (PHL):** See ISO 7498 [12].

**Portable Part (DECT Portable Part) (PP):** A physical grouping that contains all elements between the user and the DECT air interface. Portable part is a generic term that may describe one or several physical pieces.

NOTE 13: A DECT portable part is logically divided into one portable termination plus one or more portable applications.

**Portable radio Termination (PT):** A logical group of functions that contains all the DECT processes and procedures on the portable side of the DECT air interface.

NOTE 14: A PT only includes elements that are defined in the DECT CI ETS. This includes radio transmission elements (layer 1) together with a selection of layer 2 and layer 3 elements.

**Protocol Implementation Conformance Statement (PICS):** See ISO/IEC 9646-1 [11];

**PICS proforma:** See ISO/IEC 9646-1 [10];

**Radio Fixed Part (RFP):** One physical sub-group of a fixed part that contains all the Radio End Points (REPs) (one or more) that is connected to a single system of antennas.

**simplex bearer:** A simplex bearer is the MAC layer service that is created using one physical channel. See also duplex bearer and double simplex bearer.

**TDMA frame:** A time-division multiplex of 10 ms duration, containing 24 successive full slots. A TDMA frame starts with the first bit period of full slot 0 and ends with the last bit period of full slot 23.

### 3.2 Abbreviations

For the purposes of this ETS, the following abbreviations apply:

ARQ	Automatic Repeat Request
ASP	Abstract Service Primitive
BI	Invalid Behaviour
BO	Inopportune Behaviour
BV	Valid Behaviour
C-Plane	Control Plane
CA	Capability tests
C/L	Connectionless
C/O	Connection Oriented
CI	Common Interface
C <sub>S</sub>	higher layer signalling Channel (slow)
CSF	Cell Site Function
DECT	Digital Enhanced Cordless Telecommunications
DLC	Data Link Control
FP	Fixed Part
FT	Fixed radio Termination
I	higher layer Information channel (see I <sub>N</sub> and I <sub>P</sub> )
I <sub>N</sub>	higher layer Information channel (unprotected)
I <sub>P</sub>	higher layer Information channel (protected)
IUT	Implementation Under Test
LLME	Lower Layer Management Entity
LNW	Local Network
MAC	Medium Access Control
MBC	Multi-Bearer Control
N <sub>T</sub>	identities channel
PDU	Protocol Data Unit
PHL	Physical Layer
PICS	Protocol Implementation Conformance Statement
PP	Portable Part
P <sub>T</sub>	Paging channel
PT	Portable radio Termination
Q <sub>T</sub>	system information channel
REP	Radio End Point
RF	Radio Frequency
RFP	Radio Fixed Part
TDMA	Time Division Multiple Access
T-MUX	Tail MUX
TSS	Test Suite Structure
TP	Test Purposes
U-Plane	User Plane

## 4 Test suite structure

### 4.1 Overview

MAC layer is layer 2a of the DECT protocol stack.

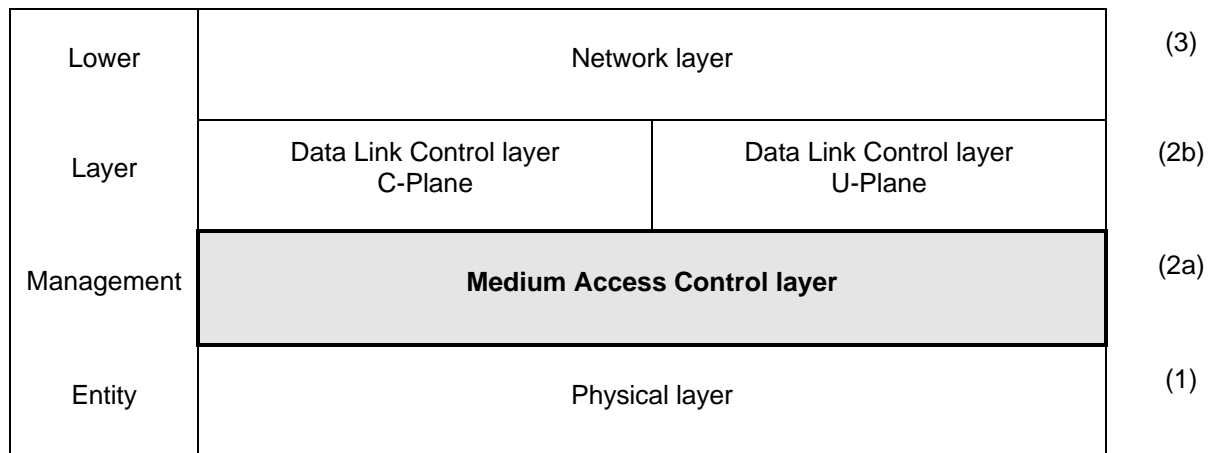

C-Plane: Control Plane  
 U-Plane User Plane

**Figure 1: DECT protocol stack**

MAC layer specifies three groups of services:

- the broadcast message control service;
- the connectionless message control service; and
- the multi-bearer control service.

The MAC layer also specifies the logical channels that are used by the above mentioned services, and how they are multiplexed and mapped into the service data units that are exchanged with the physical layer.

Figure 2 shows the MAC Test Suite Structure (TSS) including its subgroups defined for the conformance testing.

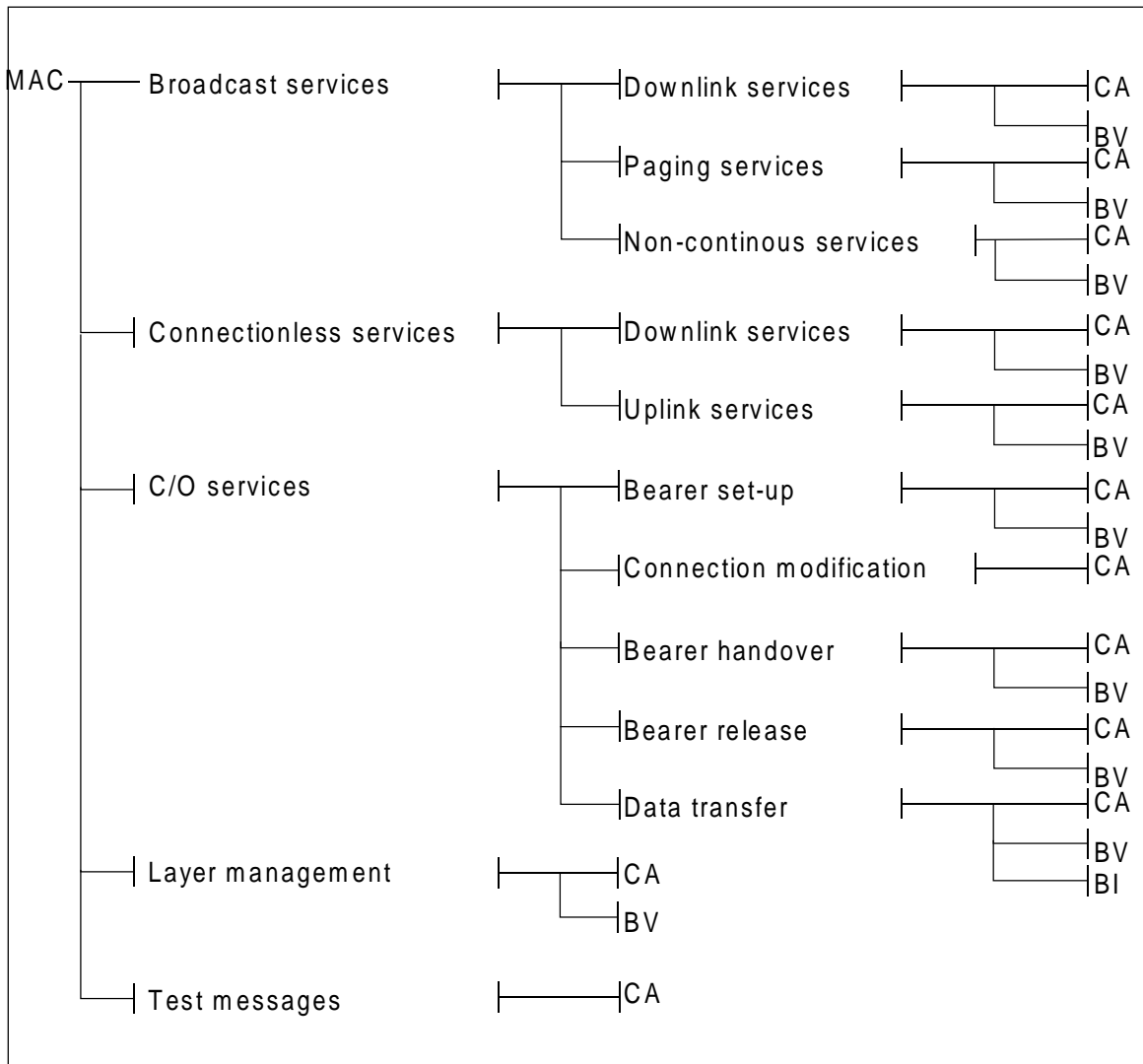

**Figure 2: TSS for DECT MAC layer (layer 2a of DECT protocol stack)**

## 4.2 TSS

The test suite is structured as a tree with a first level defined as MAC representing the protocol group "MAC for PP and FP".

## 4.3 Test groups

The test groups are organized in three levels. The first level creates five protocol groups representing the protocol services and the standard ISO main group BI. The second level, if the third level exists, separates the protocol services in functional modules. The last level in each branch contains the standard ISO subgroups CA, BV and BI.

### 4.3.1 Protocol groups

The protocol groups identifies the DECT MAC services: broadcast services, connectionless services, connection oriented services, layer management procedures, test messages procedures, as defined in ETS 300 175, Parts 1 to 8 [1] to [8].

#### **4.3.1.1 Broadcast services**

The broadcast services protocol group is divided in three functional modules. The first functional module identifies the downlink broadcast services. The second functional module identifies the paging services. The last functional module identifies the non-continuous broadcast services.

#### **4.3.1.2 Connectionless services**

The connectionless services protocol group is divided in two functional modules. The first functional module identifies the downlink connectionless services. The last functional module identifies the uplink connectionless services.

#### **4.3.1.3 Connection oriented services**

The connection oriented services protocol group is divided in five functional modules. The first functional module distinguishes the bearer setup subgroup. The second functional module distinguishes the connection modification subgroup. The third functional module distinguishes the bearer handover subgroup. The fourth functional module distinguishes the bearer release subgroup. The last functional module distinguishes the data transfer subgroup.

#### **4.3.1.4 Layer management procedures**

The layer management procedures protocol group contains directly the main test groups.

#### **4.3.1.5 Test messages procedures**

The test messages procedures protocol group contains directly the main test group CA.

### **4.3.2 Main test groups**

The main test groups are the capability group, the valid behaviour group and the invalid behaviour group.

#### **4.3.2.1 Capability (CA) tests**

This test sub group shall provide limited testing of the major IUT capabilities aiming to insure that the claimed capabilities are correctly supported, according to the PICS.

#### **4.3.2.2 Valid Behaviour (BV) tests**

This test sub group shall verify that the IUT reacts in conformity with the ETS, after receipt or exchange of a valid Protocol Data Units (PDUs). Valid PDUs means that the exchange of messages and the content of the exchanged messages are considered as valid.

#### **4.3.2.3 Invalid Behaviour (BI) tests**

This test sub group shall verify that the IUT reacts in conformity with the ETS, after receipt of a syntactically invalid PDU.

## 5 Test Purposes (TP)

### 5.1 Introduction

#### 5.1.1 TP definition conventions

The TPs are defined following particular rules as shown in table 1.

**Table 1: TP definition rules**

TP Id according to the TP naming conventions	Reference. Initial condition. Stimulus. Expected behaviour.
TP Id	The TP Id is a unique identifier it shall be specified according to the TP naming conventions defined in the subclause below.
Reference	The reference should contain the references of the subject to be validated by the actual TP (specification reference, clause, paragraph).
Condition	The condition defines in which initial state the IUT has to be to apply the actual TP.
Stimulus	The stimulus defines the test event to which the TP is related.
Expected behaviour	Definition of the events that are expected from the IUT to conform to the base specification.

#### 5.1.2 TP naming conventions

The identifier of the TP is built according to table 2.

**Table 2: TP naming convention**

<b>Identifier:</b>	<b>TP/&lt;fm&gt;/&lt;x&gt;-&lt;nn&gt;</b>		
	<fm> = functional module	DB	Downlink Broadcast
		PG	Paging services
		NB	Non Continuous Broadcast
		DC	Downlink Connectionless
		UC	Uplink Connectionless
		BS	Bearer setup
		CM	Connection modification
		BH	Bearer handover
		BR	Bearer release
		DT	Data transfer
		LM	Layer Management
		TM	Test Messages
	x = Type of testing	CA	Capability Tests
		BV	Valid Behaviour Tests
		BI	Invalid Behaviour Tests
	<nn> = sequential number	(00-99)	Test Purpose Number

#### 5.1.3 Sources of TP definitions

All TPs are specified according to ETS 300 175-3 [3].

### 5.2 Broadcast services

#### 5.2.1 Downlink broadcast

Test subgroup objective:

- verify the correct implementation of the downlink broadcast services.

5.2.1.1 CA tests

Test subgroup objective:

- limited testing that the observable capabilities of the IUT concerning the downlink broadcast service are in accordance with the static conformance requirements.

Test purposes:

<b>TP/DB/CA-00</b>	ETS 300 175-3 [3], subclause 6.2.2.1 For FT only. Initial state: Active_idle. Check that the IUT transmits constantly at least in frame 14 of each multiframe, the correct N <sub>T</sub> message.
<b>TP/DB/CA-01</b>	ETS 300 175-3 [3], subclause 6.2.2.1 - subclause 9.1.3.1 For FT only. Initial state: Active_idle. Check that the IUT transmits constantly at least once every T205 seconds in frame 0, the correct N <sub>T</sub> message.
<b>TP/DB/CA-02</b>	ETS 300 175-3 [3], subclause 6.2.2.1 - subclause 7.2.3 For FT only. Initial state: Active_idle. Check that the IUT transmits constantly one correct Q <sub>T</sub> message in frame 8 of each multiframe.
<b>TP/DB/CA-03</b>	ETS 300 175-3 [3], subclause 6.2.2.1 - subclause 7.2.3.2 For FT only. Initial state: Active_idle. Check that the IUT transmits constantly at least one static system information Q <sub>T</sub> message in each interval of 8 multiframe and that all such messages are correct.
<b>TP/DB/CA-04</b>	ETS 300 175-3 [3], subclause 6.2.2.1 - subclause 7.2.3.4 For FT only. Initial state: Active_idle. Check that the IUT transmits constantly at least one fixed part capabilities Q <sub>T</sub> message in each interval of 8 multiframe and that all such messages are correct.
<b>TP/DB/CA-05</b>	ETS 300 175-3 [3], subclause 6.2.2.1 - subclause 7.2.3 Only for FT supporting encryption. Initial state: Active_idle. Check that the IUT transmits constantly at least one multiframe number Q <sub>T</sub> message in each interval of 8 multiframe and that all such messages are correct.
<b>TP/DB/CA-06</b>	ETS 300 175-3 [3], subclause 6.2.2.1 - subclause 7.2.3.6 Only for FT supporting SARI. Initial state: Active_idle. Check that the IUT transmits constantly at least one SARI list content Q <sub>T</sub> message in each interval of 4 multiframe and that all such messages are correct.
<b>TP/DB/CA-07</b>	ETS 300 175-3 [3], subclause 6.2.2.1 - subclause 7.2.3.3 Only for FT supporting extended RF. Initial state: Active_idle. Check that the IUT transmits the correct "Extended RF carrier information" Q <sub>T</sub> message in the multi-frame following the "Static system information" Q <sub>T</sub> message with the Extended RF carrier bit set.



### 5.2.1.2 BV tests

Test subgroup objective:

- to tests the behaviour of the IUT in relation to syntactically and contextual correct behaviour of the test system.

Test purposes:

<b>TP/DB/BV-00</b>	ETS 300 175-3 [3], subclause 11.3.2 For PT only. Initial state: Active_unlocked. Check that the IUT can receive constantly from FT system information Q <sub>T</sub> message and identity N <sub>T</sub> message and to enter idle locked state.
<b>TP/DB/BV-01</b>	ETS 300 175-3 [3], subclause 7.2.3.3 For PT only. Initial state: Idle_locked. Check that the IUT is able to establish a bearer after reception of the extended RF carrier information Q <sub>T</sub> message.
<b>TP/DB/BV-02</b>	ETS 300 175-3 [3], subclause 11.3.2 For PT only. Initial state: Active_unlocked. Check that the IUT enters the idle locked state after receiving the Q <sub>T</sub> SARI list contents message.
<b>TP/DB/BV-03</b>	ETS 300 175-3 [3], subclause 6.2.2.1 - subclause 7.2.2; ETS 300 175-6 [6], subclause 7.1 For FT only. Initial state: Inactive. Check that once a SARI is introduced into the FT, the E-bit within the N <sub>T</sub> message is indicating SARI list available.

### 5.2.2 Paging services

Test subgroup objective:

- verify the correct implementation of the paging services.

#### 5.2.2.1 CA tests

Test subgroup objective:

- limited testing that the observable capabilities of the IUT concerning the paging services are in accordance with the static conformance requirements.

Test purposes:

<b>TP/PG/CA-00</b>	ETS 300 175-3 [3], subclause 9.1.3 Always for PT and FT. Initial state: Idle_locked (PT) / Active_idle (FT). Check that the IUT can receive (PT part normal idle locked mode) or transmit (FT part normal paging mode) a short page message.
<b>TP/PG/CA-01</b>	ETS 300 175-3 [3], subclause 9.1.3 For PT only. Initial state: Idle_locked. Check that the PT can receive a correct zero length page message. Only for FT that has blind slots or moving dummy bearer or does not support bearer handover within the whole FT. Initial state: Active_idle. Check that the FT can transmit a correct zero length page message.

### 5.2.2.2 BV tests

Test subgroup objective:

- to tests the behaviour of the IUT in relation to syntactically and contextual correct behaviour of the test system.

Test purposes:

<b>TP/PG/BV-00</b>	ETS 300 175-3 [3], subclause 9.1.3 Initial state: Idle_locked (PT) / Active_idle (FT). Check that the IUT manages correctly the paging Extended Flag when it transmits or receives paging messages.
<b>TP/PG/BV-01</b>	ETS 300 175-3 [3], subclause 11.8 Only for FT that shall transmit blind slot information. Initial state: Active_idle. Check that the IUT periodically announces (at least every 10s) its blind slots.
<b>TP/PG/BV-02</b>	ETS 300 175-3 [3], subclause 7.2.4.3 For PT only. Initial state: Idle_locked. Check that the PT does not setup a bearer on a slot announced to be blind, after reception of a P <sub>T</sub> blind full slot information message.
<b>TP/PG/BV-03</b>	ETS 300 175-3 [3], subclause 7.2.4.3 For PT only. Initial state: Idle_locked. Check that the PT stays locked to a FT, based on reception of other bearer and dummy or CL-bearer position zero length P <sub>T</sub> messages.

### 5.2.3 Non-continuous broadcast services

#### 5.2.3.1 CA tests

No TPs are defined for non-continuous broadcast services CA tests in this ETS.

#### 5.2.3.2 BV tests

No TPs are defined for non-continuous broadcast services BV tests in this ETS.

### 5.3 Connectionless services

#### 5.3.1 Downlink connectionless services

##### 5.3.1.1 CA tests

No TPs are defined for downlink connectionless services CA tests in this ETS.

##### 5.3.1.2 BV tests

No TPs are defined for downlink connectionless services BV tests in this ETS.

#### 5.3.2 Uplink connectionless services

##### 5.3.2.1 CA tests

No TPs are defined for uplink connectionless services CA tests in this ETS.

##### 5.3.2.2 BV tests

No TPs are defined for uplink connectionless services BV tests in this ETS.

## 5.4 Connection oriented services

### 5.4.1 Bearer setup

Test subgroup objective:

- verify the correct implementation of connection oriented bearer setup procedures.

#### 5.4.1.1 CA tests

Test subgroup objective:

- limited testing that the observable capabilities of the IUT concerning the connection oriented bearer setup procedures are in accordance with the static conformance requirements.

Test purposes:

<b>TP/BS/CA-00</b>	ETS 300 175-3 [3], subclause 10.5.1.1 For PT only. Initial state: Idle_locked. Check that the IUT manages rightly the PT initiated (single) basic bearer setup procedure without wait messages. For FT only. Initial state: Active_idle. Check that the IUT manages rightly the PT initiated (single) basic bearer setup procedure.
<b>TP/BS/CA-01</b>	ETS 300 175-3 [3], subclause 10.5.1.1 For PT only. Initial state: Idle_locked. Check that the IUT manages rightly the PT initiated (single) basic bearer setup procedure with wait messages.

#### 5.4.1.2 BV tests

Test subgroup objective:

- to test the behaviour of the IUT in relation to syntactically and contextual correct behaviour of the test system.

Test purposes:

<b>TP/BS/BV-00</b>	ETS 300 175-3 [3], subclause 10.5.1.1 - subclause 11.5.1 Initial state: Active_locked (PT) / Active_traffic or Active_traffic_and_idle (FT). Check that the IUT releases a duplex bearer in case the timer T201 expires during the time a basic bearer exists.
--------------------	--

## 5.4.2 Connection modification

### 5.4.2.1 CA tests

No TPs are defined for connection modification CA tests in this ETS.

### 5.4.3 Bearer handover

Test subgroup objective:

- verify the correct implementation of connection oriented bearer handover procedures.

5.4.3.1 CA tests

Test subgroup objective:

- limited testing that the observable capabilities of the IUT concerning the connection oriented bearer handover procedures are in accordance with the static conformance requirements.

Test purposes:

<b>TP/BH/CA-00</b>	ETS 300 175-3 [3], subclause 10.6 For PT only. Initial state: Active_locked. Check that the IUT, for a duplex bearer, correctly initiates and completes an intracell bearer handover procedure using basic set-up. Only for FT supporting intracell bearer handover. Initial state: Active_traffic or Active_traffic_and_idle. Check that the IUT responds rightly to a PT initiated intracell bearer handover procedure.
<b>TP/BH/CA-01</b>	ETS 300 175-3 [3], subclause 10.6 For PT only. Initial state: Active_locked. Check that the IUT, for a duplex bearer, correctly initiates and completes an intercell bearer handover procedure using basic set-up. Only for FT supporting intercell bearer handover. Initial state: Active_traffic or Active_traffic_and_idle. Check that the IUT responds rightly to a PT initiated intercell bearer handover procedure.

5.4.3.2 BV tests

Test subgroup objective:

- to test the behaviour of the IUT in relation to syntactically and contextual correct behaviour of the test system.

Test purposes:

<b>TP/BH/BV-00</b>	ETS 300 175-3 [3], subclause 10.6; ETS 300 175-7 [7], subclause 6.4.7 For PT only. Initial state: Active_locked. Check that the IUT, for a duplex bearer, correctly initiates and completes an intracell bearer handover procedure using basic set-up when encryption is enabled. Only for FT supporting intracell bearer handover. Initial state: Active_traffic or Active_traffic_and_idle. Check that the IUT responds rightly to a PT initiated intracell bearer handover procedure when encryption is enabled.
<b>TP/BH/BV-01</b>	ETS 300 175-3 [3], subclause 10.6; ETS 300 175-7 [7], subclause 6.4.7 For PT only. Initial state: Active_locked. Check that the IUT, for a duplex bearer, correctly initiates and completes an intercell bearer handover procedure using basic set-up when encryption is enabled. Only for FT supporting intercell bearer handover. Initial state: Active_traffic or Active_traffic_and_idle. Check that the IUT responds rightly to a PT initiated intercell bearer handover procedure when encryption is enabled.

#### 5.4.4 Bearer release

Test subgroup objective:

- verify the correct implementation of connection oriented bearer release procedures.

##### 5.4.4.1 CA tests

Test subgroup objective:

- limited testing that the observable capabilities of the IUT concerning the connection oriented bearer release procedures are in accordance with the static conformance requirements.

Test purposes:

<b>TP/BR/CA-00</b>	ETS 300 175-3 [3], subclause 10.7.2.1 Initial state: Active_locked (PT) / Active_traffic or Active_traffic_and_idle (FT). Check that the IUT manages rightly a release of a basic duplex bearer with an unacknowledged release procedure when receiving a release message.
--------------------	--

##### 5.4.4.2 BV tests

No TPs are defined for bearer release BV tests in this ETS.

#### 5.4.5 Data transfer

Test subgroup objective:

- verify the correct implementation of connection oriented data transfer procedures.

5.4.5.1 CA tests

Test subgroup objective:

- limited testing that the observable capabilities of the IUT concerning the connection oriented data transfer procedures are in accordance with the static conformance requirements.

Test purposes:

<b>TP/DT/CA-00</b>	ETS 300 175-3 [3], subclause 10.8.1.1 Initial state: Active_locked (PT) / Active_traffic or Active_traffic_and_idle (FT). Check that the IUT re-transmits $C_S$ segment until it receives an acknowledgement in the same Automatic Repeat Request (ARQ) window.
<b>TP/DT/CA-01</b>	ETS 300 175-3 [3], subclause 10.8.1.1 Initial state: Active_locked (PT) / Active_traffic or Active_traffic_and_idle (FT). Check that the IUT does not transmit another $C_S$ segment until the successful transmission of the current segment.
<b>TP/DT/CA-02</b>	ETS 300 175-3 [3], subclause 10.8.1.1 Initial state: Active_locked (PT) / Active_traffic or Active_traffic_and_idle (FT). Check that the IUT manages correctly the one bit numbering of the $C_S$ segments.
<b>TP/DT/CA-03</b>	ETS 300 175-7 [7], subclause 6.4.6 - subclause 6.4.6.3 Always for PT and only for FT supporting encryption. Initial state: Active_locked (PT) / Active_traffic or Active_traffic_and_idle (FT). Check that the IUT manages correctly the procedure to switch the basic connection from clear mode to encrypt mode.
<b>TP/DT/CA-04</b>	ETS 300 175-7 [7], subclause 6.4.6 - subclause 6.4.6.4 Only for IUT supporting encryption deactivation. Initial state: Active_locked (PT) / Active_traffic or Active_traffic_and_idle (FT). Check that the IUT manages correctly the procedure to switch the basic connection from encrypt mode to clear mode.

5.4.5.2 BV tests

Test subgroup objective:

- to test the behaviour of the IUT in relation to syntactically and contextual correct behaviour of the test system.

Test purposes:

<b>TP/DT/BV-00</b>	ETS 300 175-7 [7], subclause 6.4.6 - subclause 6.4.6.3 Initial state: Active_locked (PT) / Active_traffic or Active_traffic_and_idle (FT). Check that the IUT releases the basic connection when it cannot conclude the procedure to switch from clear mode to encrypt mode.
<b>TP/DT/BV-01</b>	ETS 300 175-7 [7], subclause 6.4.6 - subclause 6.4.6.4 Only for IUT supporting encryption deactivation. Initial state: Active_locked (PT) / Active_traffic or Active_traffic_and_idle (FT). Check that the IUT releases the basic connection when it cannot conclude the procedure to switch from encrypt mode to clear mode.

### 5.4.5.3 BI tests

Test subgroup objective:

- to check the behaviour of the of the IUT in response to invalid messages.

Test purposes:

<b>TP/DT/BI-00</b>	ETS 300 175-3 [3], subclause 10.8.1.3 Initial state: Active_locked (PT) / Active_traffic or Active_traffic_and_idle (FT). Check that the IUT, when receiving I <sub>N</sub> minimum delay data, is capable to detect A-field R-CRC error and to respond with the correct Q2 bit setting (Q2 = 0).
<b>TP/DT/BI-01</b>	ETS 300 175-3 [3], subclause 10.8.1.3 For FT only. Initial state: Active_traffic or Active_traffic_and_idle. Check that the IUT sets the Q1 & Q2 bits correctly when it receives data with Z-field error during I <sub>N</sub> minimum delay transfer.

## 5.5 Layer management procedures

Test subgroup objective:

- verify the correct implementation of the LLME MAC layer management procedures.

### 5.5.1 CA tests

Test subgroup objective:

- limited testing that the observable capabilities of the IUT concerning the LLME MAC layer management procedures are in accordance with the static conformance requirements.

Test purposes:

<b>TP/LM/CA-00</b>	ETS 300 175-3 [3], subclause 10.2 For PT only. Initial state: Idle_locked (PT). Check that the IUT manages rightly the protocol constant N200.
<b>TP/LM/CA-01</b>	ETS 300 175-3 [3], subclause 10.2 For PT only. Initial state: Idle_locked (PT). Check that the IUT manages rightly the protocol timer T200.
<b>TP/LM/CA-02</b>	ETS 300 175-3 [3], subclause 11.3 and subclauses For PT only. Initial state: Idle_locked. Check that the IUT manages rightly the protocol timer T207.
<b>TP/LM/CA-03</b>	ETS 300 175-3 [3], subclause 11.3 For PT only. Initial state: Idle_locked. Check that the IUT manages rightly the protocol timer T208.
<b>TP/LM/CA-04</b>	ETS 300 175-3 [3], subclause 10.6.2 For PT only. Initial state: Active_locked. Check that the IUT makes at most N201 bearer setup attempts for bearer handover of one particular bearer and within a time window of T202 seconds.
<b>TP/LM/CA-05</b>	ETS 300 175-3 [3], subclause 10.6.2 For FT only. Initial state: Active_traffic or Active_traffic_and_idle. Check that the IUT, after the establishment of a new bearer during bearer handover, releases one of the two bearers within a time interval of T203 seconds.

### 5.5.2 BV tests

No TPs are defined for layer management procedures BV tests in this ETS.

## 5.6 Test messages procedures

### 5.6.1 CA tests

No TPs are defined for test messages procedures CA tests in this ETS.



## **Annex A (informative): Bibliography**

The following references are provided for information.

- 1) EWOS/ETSI Project Team No 5: "Project Report and Technical Report. OSI Conformance Testing Methodology and Procedures in Europe".
- 2) ETR 022: "Advanced Testing Methods (ATM); Vocabulary of terms used in communications protocols conformance testing".
- 3) ETR 141: "Methods for Testing and Specification (MTS); Protocol and profile conformance testing specifications; The Tree and Tabular Combined Notation (TTCN) style guide".
- 4) CEPT Recommendation T/SGT SF2 (89) 6/0: "Draft Recommendation T/SF Services and Facilities of Digital Enhanced Cordless Telecommunications".
- 5) ETR 015: "Radio Equipment and Systems (RES); Digital Enhanced Cordless Telecommunications (DECT); Reference document".
- 6) ETR 041 "Transmission and Multiplexing (TM); Digital Enhanced Cordless Telecommunications (DECT); Transmission aspects 3,1 kHz telephony Interworking with other networks".
- 7) ETR 042 "Radio Equipment and Systems (RES); Digital Enhanced Cordless Telecommunications (DECT) A Guide to DECT features that influence the traffic capacity and the maintenance of high radio link transmission quality, including the results of simulations".
- 8) ETR 043: "Radio Equipment and Systems (RES); Digital Enhanced Cordless Telecommunications (DECT); Common interface Services and Facilities requirements specification".
- 9) ETR 056: "Radio Equipment and Systems (RES); Digital Enhanced Cordless Telecommunications (DECT); System description document".

## History

Document history	
August 1996	First Edition
February 1997	Public Enquiry PE 9724: 1997-02-14 to 1997-06-13