



**E**UROPEAN  
**T**ELECOMMUNICATION  
**S**TANDARD

**ETS 300 471**

December 1995

---

Source: ETSI TC-RES

Reference: DE/RES-02-14

ICS: 33.060.20

**Key words:** access, data, mobile, protocol, radio, testing

**Radio Equipment and Systems (RES);  
Land mobile service;  
Access protocol, occupation rules and corresponding technical  
characteristics of radio equipment for the  
transmission of data on shared channels**

**ETSI**

European Telecommunications Standards Institute

**ETSI Secretariat**

**Postal address:** F-06921 Sophia Antipolis CEDEX - FRANCE

**Office address:** 650 Route des Lucioles - Sophia Antipolis - Valbonne - FRANCE

**X.400:** c=fr, a=atlas, p=etsi, s=secretariat - **Internet:** secretariat@etsi.fr

Tel.: +33 92 94 42 00 - Fax: +33 93 65 47 16

---

**Copyright Notification:** No part may be reproduced except as authorized by written permission. The copyright and the foregoing restriction extend to reproduction in all media.

© European Telecommunications Standards Institute 1995. All rights reserved.



## Contents

Foreword .....	5
1 Scope .....	7
2 Normative references .....	7
3 Definitions .....	8
4 General .....	8
4.1 Sharing speech/data .....	8
4.2 Sharing data/data .....	8
4.3 Conformity to this ETS .....	8
4.4 Interpretation of the measurement results .....	9
5 Technical characteristics of the equipment .....	9
6 Access protocol .....	9
6.1 General .....	9
6.2 Principles .....	9
6.3 Procedure .....	9
6.4 Carrier sensing .....	10
6.5 Observation time .....	10
6.6 Initiation of the transmitter .....	11
6.7 Duration of the RF channel occupation (time interval) .....	11
6.7.1 Transmissions of data packets exceeding 300 ms .....	11
6.7.2 Transmissions of data packets not exceeding 300 ms (speech/data channels) .....	11
7 Examples of sharing situations .....	12
8 Methods of measurement for receiver delays .....	17
8.1 Carrier sense delay .....	17
8.1.1 Definition .....	17
8.1.2 Method of measurement .....	17
8.1.3 Limit .....	18
8.2 Receiver opening delay .....	18
8.2.1 Definition .....	18
8.2.2 Method of measurement .....	18
8.2.3 Limit .....	19
9 Measurement uncertainty .....	19
Annex A (normative): General arrangements for measurements involving the use of radiated fields .....	20
A.1 Test fixture .....	20
A.1.1 Description .....	20
A.1.2 Calibration .....	20
A.1.3 Mode of use .....	21
A.2 Acoustic coupler .....	21
A.2.1 General .....	21
A.2.2 Description .....	21
A.2.3 Calibration .....	22
A.3 Bibliography .....	22

Annex B (informative):	Comments concerning the random part of the observation time.....	23
Annex C (informative):	Comments concerning the traffic loading of shared channels.....	24
History .....		25

## Foreword

The access protocol described in this ETS is based on the access protocol published as annex F of I-ETS 300 113 [3].

<b>Transposition dates</b>	
Date of adoption of this ETS:	17 November 1995
Date of latest announcement of this ETS (doa):	31 March 1996
Date of latest publication of new National Standard or endorsement of this ETS (dop/e):	30 September 1996
Date of withdrawal of any conflicting National Standard (dow):	30 September 1996

This ETS can be implemented for equipment meeting the requirements of ETSI standards e.g. ETS 300 113 [1] and ETS 300 390 [2].

Blank page

## 1 Scope

This ETS applies to equipment designed to operate within the professional mobile radio service and to the associated frequency planning.

This ETS applies to equipment for the transmission of data on shared channels; it also contains two methods of measurement used for the assessment of receiver timing parameters.

This ETS specifies an access protocol and occupation rules for data communications on radio channels shared by different users. It may be used for data communications over channels originally intended for speech use. This ETS gives freedom for the use of any bit rate, any constant envelope modulation or any type of protocol which fulfills the normative parameters of this ETS to access a shared radio channel.

The access protocol specified in this ETS also permits the sharing of speech and data communication.

This access protocol applies to single frequency simplex operation (and two frequency repeater operations with the repeater in duplex mode and the mobile units in simplex mode). This access protocol is applicable for:

- multiple data only users, independent of each other, which do not share a common central control facility, but may share a common single or two frequency radio channel;
- multiple mixed analogue speech and data users, independent from each other, which do not share a common central control facility, but may share a common single, or two frequency, radio channel and where speech is to have priority over data transmissions.

This access protocol is not applicable for data users with common central control facilities or for trunked systems operating on dedicated non shared channels.

In the case of analogue transmissions, the corresponding access protocol is known as the "radio-discipline" of the users.

Within the limits set out in this ETS, each group of users may use its own communication protocol.

## 2 Normative references

This ETS incorporates by dated and undated reference, provisions from other publications. These normative references are cited at the appropriate places in the text and the publications are listed hereafter. For dated references, subsequent amendments to or revisions of any of these publications apply to this ETS only when incorporated in it by amendment or revision. For undated references the latest edition of the publication referred to applies.

- [1] prETS 300 113 (1995): "Radio Equipment and Systems (RES); Land mobile service; Technical characteristics and test conditions for radio equipment intended for the transmission of data (and speech) and having an antenna connector".
- [2] prETS 300 390 (1995): "Radio Equipment and Systems (RES); Land mobile service; Technical characteristics and test conditions for radio equipment intended for the transmission of data and speech and using an integral antenna".
- [3] I-ETS 300 113 (1992): "Radio Equipment and Systems (RES); Land mobile service Technical characteristics and test conditions for non-speech and combined analogue speech/non-speech equipment with an internal or external antenna connector, intended for the transmission of data".

### 3 Definitions

For the purpose of this ETS, the following definitions apply:

**bit:** Binary digit.

**block:** The smallest quantity of information sent over the radio channel. A constant number of useful bits are always sent together with the corresponding redundancy bits.

**packet:** One block or a contiguous stream of blocks sent by one (logical) transmitter to one particular receiver or one particular group of receivers.

**burst (physical):** Transmission of a small number of consecutive packets within a period not exceeding 300 ms in accordance with this access protocol.

**transmission (physical):** One or several packets transmitted between power on and power off of a particular transmitter.

**window:** A set of inter-related transmissions resulting from the action of the "initiating transmitter", and limited in time by the access protocol and corresponding occupation rules to a duration of  $t_t + \Delta t_t$ .

**session:** A set of inter-related exchanges of packets occupying one or several windows or parts thereof (if applicable). It corresponds to a complete interactive procedure for interchanging data between users, comprising initiation, data transmission and termination procedures. The session can be short (e.g. 2 packets) or long (e.g. one full page of text).

**message:** User data to be transferred in one or more packets in a session.

**initiating transmitter:** The initiating transmitter is the station that has completed the "observation time" (see subclause 6.5) and therefore starts a transmission. This initiates a window and triggers the timer  $t_t$ .

**reply:** A transmission by a station as an answer to the "initiating transmitter". This reply can be an acknowledge ("ACK") or a negative acknowledge ("NACK") or a longer packet of useful information.

### 4 General

#### 4.1 Sharing speech/data

This access protocol gives speech priority over data on mixed speech/data channels. In order to limit annoyance to speech users, the duration of data transmissions shall be limited in accordance with subclause 6.7.

#### 4.2 Sharing data/data

On frequencies assigned only to data communication users (without common central control facilities) the access protocol provides access to independent users with equal priority.

#### 4.3 Conformity to this ETS

A signed declaration shall be provided as a confirmation that the equipment meets the requirements of this access protocol. This may be submitted by the manufacturer with the application form for tests.

In the case where the controlling software for the equipment has not been engineered by the manufacturer of the radio equipment, the party responsible for engineering the controlling software shall provide a signed declaration that the equipment meets the requirements of this access protocol.

Measurements of receiver carrier sense delay and opening delay shall be performed in an accredited test laboratory, possibly together with the tests corresponding to ETS 300 113 [1].



#### 4.4 Interpretation of the measurement results

The interpretation of the results recorded in a test report for the measurements described in this ETS shall be as follows:

- a) the measured value related to the corresponding limit shall be used to decide whether an equipment meets the minimum requirements of this ETS;
- b) the actual measurement uncertainty of the test laboratory carrying out the measurement, for each particular measurement, shall be included in the test report;
- c) the values of the actual measurement uncertainty shall be, for each measurement, equal to or lower than the figures given in clause 9 (absolute measurement uncertainties).

### 5 Technical characteristics of the equipment

The timing requirements that the equipment shall fulfil in order to operate correctly and efficiently can be found in ETS 300 113 [1], subclauses 5.1.7 and 5.1.8, ETS 300 390 [2], subclauses 5.1.5 and 5.1.6 and subclauses 8.1.3 and 8.2.3 of this ETS.

The corresponding methods of measurement can be found in ETS 300 113 [1], subclauses 8.8 and 8.9, ETS 300 390 [2], subclauses 8.5 and 8.6 and in subclauses 8.1 and 8.2, of this ETS.

### 6 Access protocol

#### 6.1 General

The access protocol shall be used for each occupation of the Radio Frequency (RF) channel for sharing data/data and for sharing speech/data with automatic channel access.

#### 6.2 Principles

The equipment determines whether or not the channel is, and has been, idle for a certain period (the observation time) by means of carrier sensing.

The observation time consists of a fixed part and a randomly selected part. When the channel still appears to be idle at the end of the observation time, the transmitter is initiated and powered up within a specified time.

The duration of the emission is limited (see subclause 6.7).

#### 6.3 Procedure

The equipment shall determine whether or not the channel is, and has been, idle for a certain period (the observation time  $t_o$ ), by means of carrier sensing (see subclause 6.4). The observation time  $t_o$  consists of a fixed part  $t_f$  and a randomly selected part  $t_r$ .

If the channel is occupied during part of the observation time, the process shall be repeated (without changing  $m$  (see subclause 6.5)).

If the channel appears to be idle throughout the observation time, the transmitter shall be initiated and powered up within the specified time (attack time; see ETS 300 113 [1], subclause 8.8 or ETS 300 390 [2], subclause 8.5). The channel can then be seized for the duration of one time interval. The maximum length  $t_i$  of this interval depends on the frequency sharing category (data/speech, data/data).

If a re transmission is required (due, for example, to a "collision", i.e. a simultaneous channel access by several users), the observation process shall be repeated and the channel shall be detected as idle prior to a repetition of a transmission.

Within one time interval, the following radio traffic may take place:

- a) from a base station to one or several mobiles;
- b) from a mobile to a base station;
- c) between mobiles.

To ensure that no other user can access the channel during a time interval, the reversion time  $t_c$ , the time between transmission of a message and reception of the corresponding acknowledgement and/or reply, shall not exceed 50 ms. The reversion time  $t_c$  is the time between the switch off of one transmitter and the switch on of the other. The points of switch off and switch on are considered to be the points at which the transmitter power is 50 % of the rated carrier power.

#### 6.4 Carrier sensing

Carrier sensing is the detection of whether the RF level in the receive channel exceeds a given threshold.

The carrier sense shall be able to detect RF signals with different types of modulation (e.g. F3E, G3E, F1D, F2D, G1D).

The channel shall be regarded as in use during the observation time (see subclause 6.5) if the level of the RF signal on the channel exceeds a certain level. For equipment meeting ETS 300 113 [1] or I-ETS 300 113 [3], this threshold level shall be as defined in table 1.

Table 1: Threshold levels

Band	Threshold level in dB $\mu$ V emf
30 - 137 MHz	12
> 137 - 300 MHz	6
> 300 MHz	0

The carrier sense delay is specified in subclause 8.1.3.

#### 6.5 Observation time

The observation time shall start within 10 ms after each time that the RF channel has become idle. It shall also start at power on.

The observation time  $t_o$  is the sum of the fixed part  $t_f$  and the random part  $t_r = n \times t_i$

$$t_o = t_f + n \times t_i.$$

The fixed part,  $t_f$ , of the observation time shall be:

- on pure data channels: 60 ms  $\pm$  1 ms;
- on combined speech/data channels: 2 000 ms  $\pm$  1 ms;

except as specified in subclause 6.7.2.

The increment time  $t_i$  shall be 50 ms  $\pm$  0,1 ms.

The number  $n$  is a random integer number from 1 to  $m$  ( $1 \leq n \leq m$ ); this means that 1 to  $m$  is the event field of the random number  $n$ . The random number  $n$  shall be determined by use of a random generator with a uniform distribution (see also annex B).

To achieve short delays during low traffic, the observation time should be short, i.e.  $m$  should be small. Therefore in this access protocol,  $m$  shall be set to 4 for the first trial.

A short random part of the observation time however, increases the probability of several users simultaneously accessing the channel for a time interval.

Therefore, when a re transmission is required (e.g. in the case of no acknowledge, see figure 2), the observation process shall be repeated and the channel shall be detected as idle during a new  $t_o$  before a repetition of the transmission takes place. The event field (1 to  $m$ ) shall be doubled with each trial. In this way, channel congestion can be reduced even with short initial observation times.

For the second trial (transmission of the same message)  $m$  shall be set to 8, etc. until  $m = 64$ .

## 6.6 Initiation of the transmitter

If the channel has not been occupied since the start of the observation time, then the transmitter may be initiated. The time which elapses between the end of the observation time and the moment that the carrier power from the transmitter has reached a level of 1 dB below the steady state power shall not exceed 25 ms (see transmitter attack time, ETS 300 113 [1], subclause 8.8 or ETS 300 390 [2], subclause 8.5).

## 6.7 Duration of the RF channel occupation (time interval)

### 6.7.1 Transmissions of data packets exceeding 300 ms

The time interval during which packets of data can be sent by the initiating transmitter to the addressed parties is called  $t_t$ . To ensure that only the initiating transmitter monitors the time interval, acknowledgements and replies may exceed the time interval  $t_t$  by the time  $\Delta t_t$ . This determines the duration of the windows (see definitions in clause 3). Equipment designed to comply with this access protocol shall provide for the following ranges and step sizes:

$$t_t = 1, \dots, 10 \text{ s step size } 100 \text{ ms};$$

$$\Delta t_t = 0, 1, \dots, 10 \text{ s step size } 100 \text{ ms}.$$

The actual value of  $t_t$  and  $\Delta t_t$  may be set by the appropriate administration.

The total time interval during which a packet of data can be sent, as expressed in this subclause, may be a condition to the issue of a licence by the appropriate administration.

### 6.7.2 Transmissions of data packets not exceeding 300 ms (speech/data channels)

On mixed speech/data channels additional short data bursts of a duration not exceeding 300 ms can be transmitted. The start of the observation time is determined according to subclause 6.5. The observation time (with carrier sense) before such transmissions shall be equal to the random part stated in subclause 6.5, but in this particular case the value of  $n$  shall be set to an integer number from 2 to  $m$  (the fixed part of the observation time shall be zero).

If a re-transmission is necessary or if another burst is to be transmitted, this procedure may only be repeated after two seconds (fixed part of the observation time).

## **7 Examples of sharing situations**

Figures 1 to 4 illustrate the protocol as described.

Sharing data/data; users operating independently.

Observation time  $t_o = t_f + nt_i$ ;  $t_f = 60$  ms;  $t_i = 50$  ms

$n =$  random number between 1, 2, ...,  $m$ .

$t_t = 1, \dots, 10$  s      step size 100 ms

$t_t = 0, 1, \dots, 10$  s      step size 100 ms

Figure 1: Access protocol sharing data/data

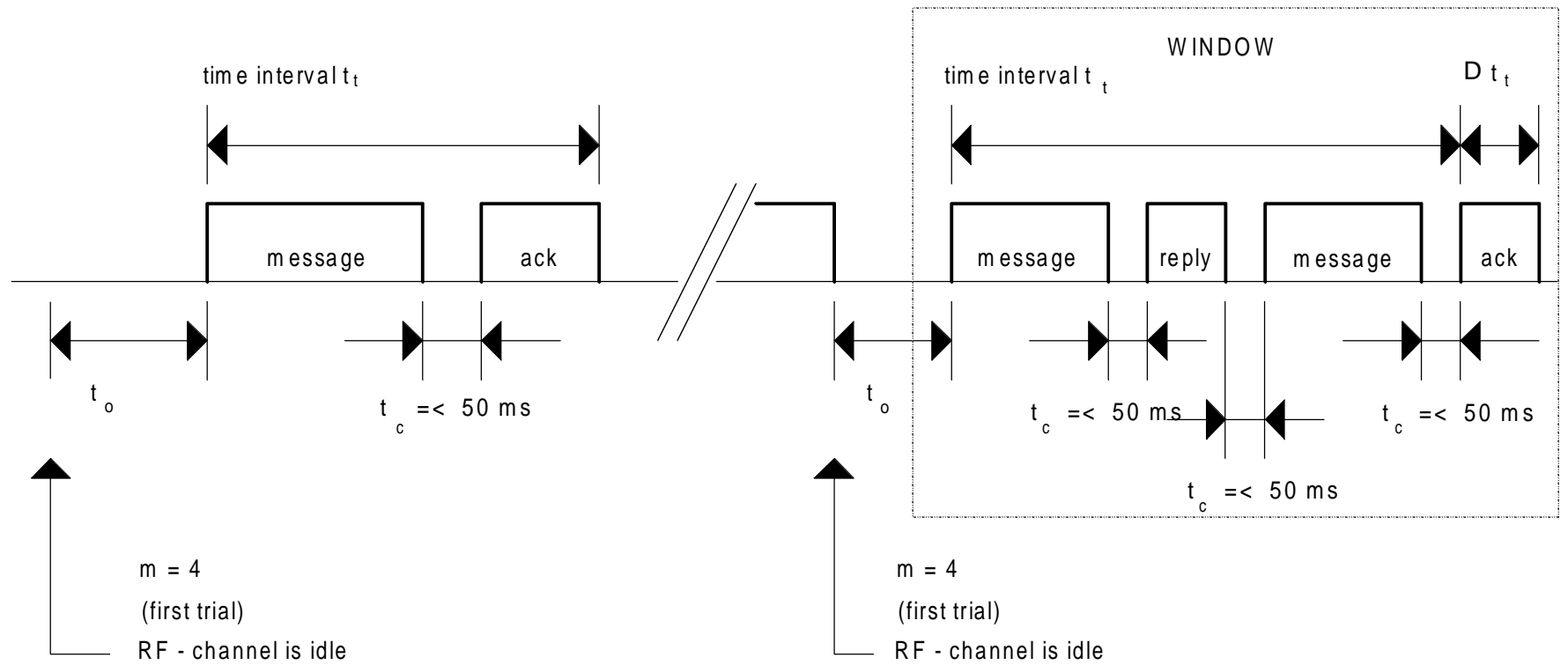

Sharing data/data; users operating independently.

Example with an unsuccessful transmission.

Observation time  $t_o = t_f + nt_i$ ;  $t_f = 60$  ms;  $t_i = 50$  ms

$n =$  random number between 1, 2, ...,  $m$ .

Figure 2: Access protocol: unsuccessful transmission

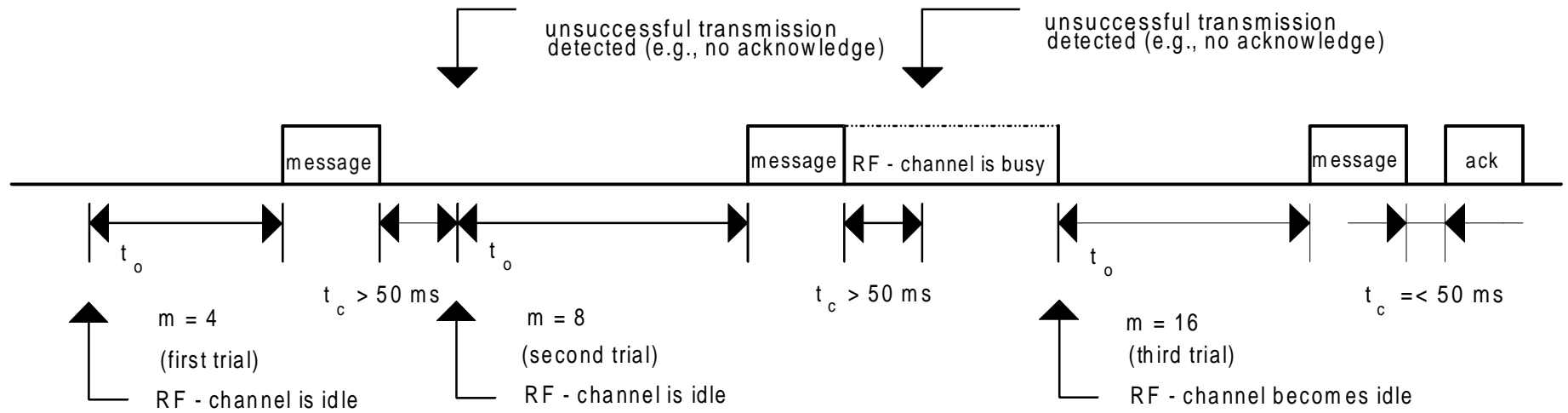

Sharing data/data; users operating independently.

$t_t = 1, \dots, 10$  s      step size 100 ms

Observation time  $t_o = t_f + nt_i$  ;  $t_f = 60$  ms;  $t_i = 50$  ms

$t_t = 0,1 \dots 10$  s      step size 100 ms

$n =$  random number between 1, 2, ...,  $m$ .

Figure 3: Access protocol sharing data/data

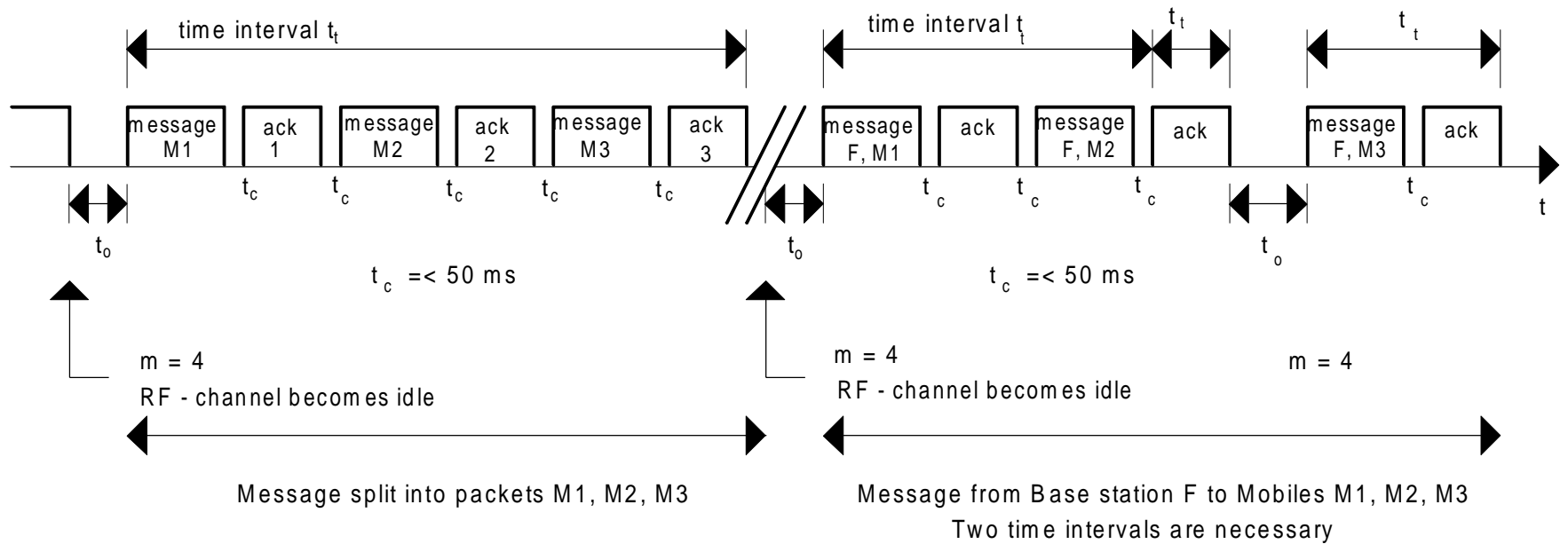

Sharing speech/data; users operating independently.  
 Observation time  $t_o = t_f + nt_i$ ;  $t_f = 2000$  ms;  $t_i = 50$  ms  
 $n = \text{random number between } 1, 2, \dots, m.$

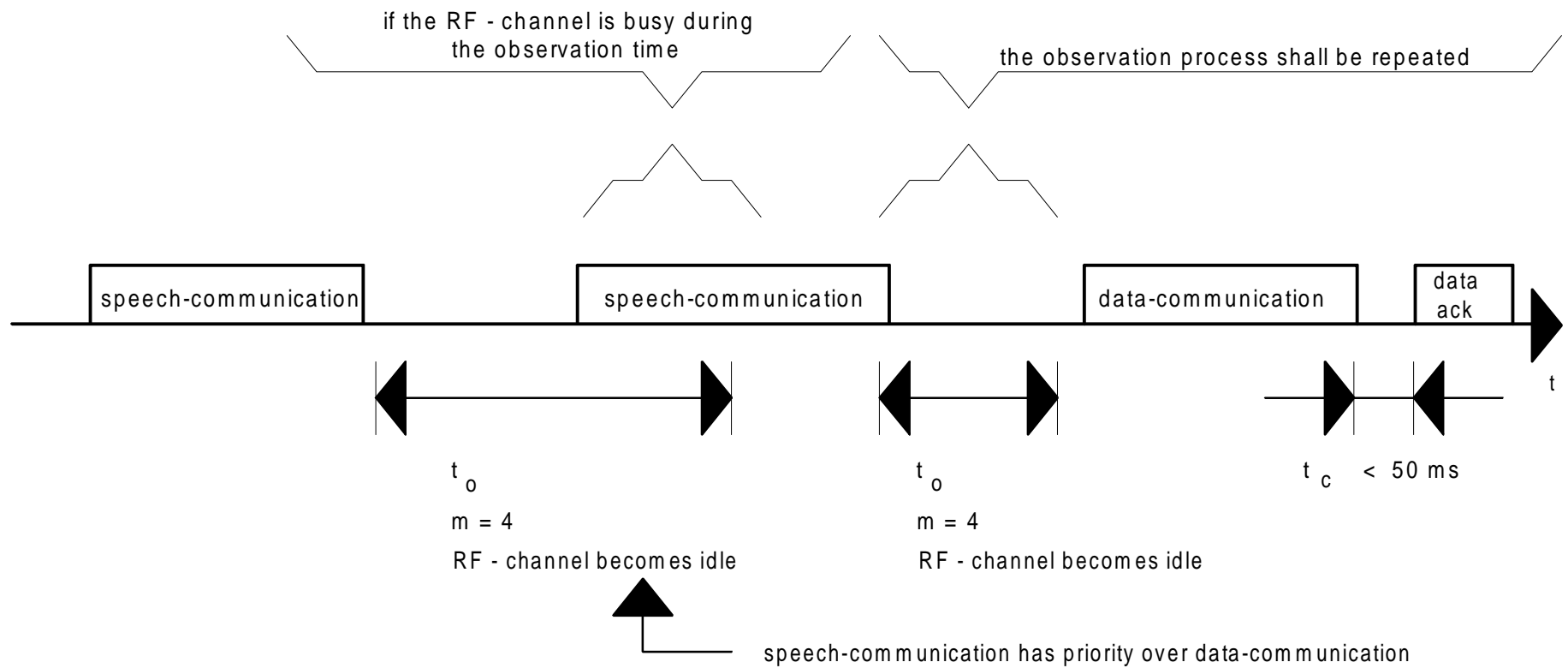

Figure 4: Sharing speech/data



## 8 Methods of measurement for receiver delays

A number of parameters relating to data equipment are assessed by testing to other ETSs. Therefore, any limits quoted refer to the ETS to which the equipment is type tested.

### 8.1 Carrier sense delay

#### 8.1.1 Definition

The carrier sense delay is the time which elapses between the application of a carrier to the receiver and the detection of the carrier by that receiver.

#### 8.1.2 Method of measurement

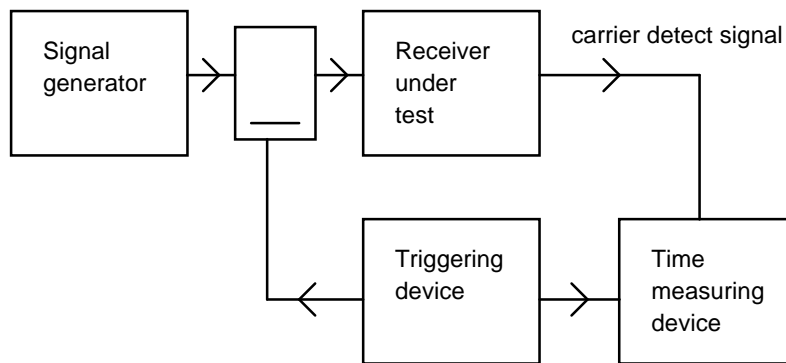

Figure 5: Measurement arrangement for equipment with an antenna connector

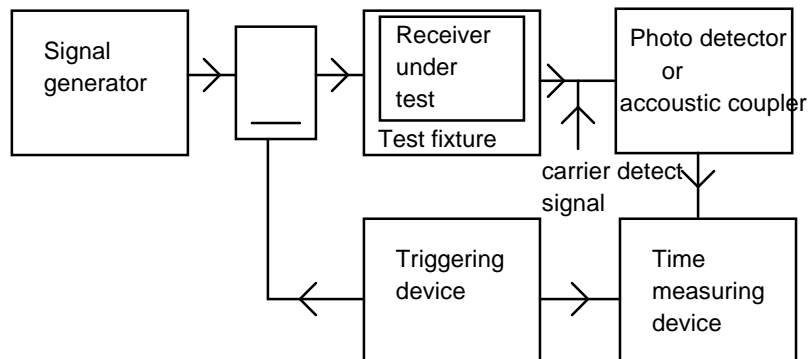

Figure 6: Measurement arrangement for equipment with an integral antenna

In the case of equipment with an internal or external antenna connector, the receiver shall be connected to a signal generator with the frequency equal to the nominal frequency of the receiver (see figure 5). The receiver under test shall provide a measurement point where the "carrier detect signal" can be observed. The level of the wanted signal provided by the signal generator is set to 6 dB above the limit of the maximum usable sensitivity (data or messages).

In the case of integral antenna equipment, the receiver shall be placed in a test fixture (see figure 6 and annex A). The receiver under test shall be coupled by a method which does not affect the radiated field in such a way that the "carrier detect signal" can be observed. The wanted signal provided by the signal generator shall be at the nominal frequency of the receiver. Its level shall be adjusted to a level which is 3 dB above the level equivalent to the limit of the average usable sensitivity (data or messages) for the category of equipment used, expressed as a field strength (see ETS 300 390 [2], subclauses 5.2.1 and 9.1.6). This level is the level which has already been used when performing the degradation measurements required by ETS 300 390 [2].

In both cases, the test signal ("test carrier") shall be switched on and off by means of a (logical) input signal. The rise and decay time of this signal shall be less than 1 ms. The delay between the application of the test carrier and the detection by the receiver shall be noted.

The measurement shall be carried out with:

- a) an unmodulated carrier;
- b) a carrier modulated with 400 Hz, with a deviation corresponding to 12 % of the channel separation;
- c) a carrier modulated with data similar to the data format/modulation used by the equipment.

**8.1.3 Limit**

The carrier sense delay shall be less than or equal to 10 ms.

**8.2 Receiver opening delay**

**8.2.1 Definition**

The receiver opening delay is the time which elapses between the application of a test signal ("test carrier") to the receiver and the moment when the receiver is able to receive information without exceeding a given degradation.

**8.2.2 Method of measurement**

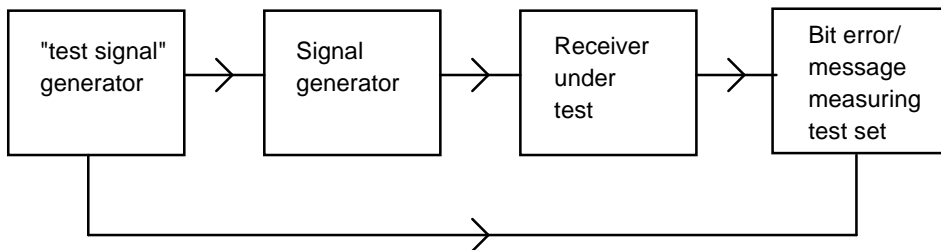

**Figure 7: Measurement arrangement for equipment with an antenna connector**

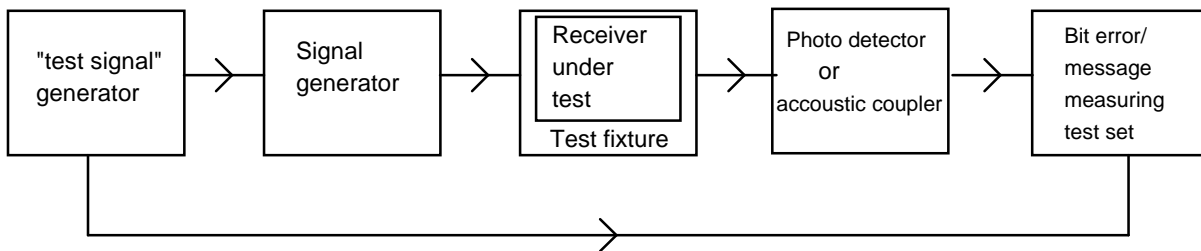

**Figure 8: Measurement arrangement for equipment with an integral antenna**

In the case of equipment with an internal or external antenna connector, the receiver shall be connected to a signal generator with the frequency equal to the nominal frequency of the receiver (see figure 7). A test signal with a level of 20 dB above the limit of the maximum usable sensitivity (data or messages) shall be applied to the receiver at a known instant.

In the case of integral antenna equipment, the receiver shall be placed in a test fixture (see figure 8 and annex A). The signal generator providing the input signal shall be at the nominal frequency of the receiver. A test signal with a level of 20 dB above the level equivalent to the limit of the average usable sensitivity (data or messages) for the category of equipment used, expressed as a field strength (see ETS 300 390 [2], subclauses 5.2.1 and 9.1.6), shall be applied to the receiver at a known instant.

In both cases, after the delay of 15 ms, which shall be subsequently decremented in steps of 1 ms in order to determine the real value of the parameter (see subclause 8.2.3), the test signal shall be

modulated by a data signal, consisting of an appropriate synchronising sequence and a pseudo-random bit sequence of 511 bits or a correctly coded message.

When a coded message has to be used, the measurement shall be repeated three times. The number of errors shall be noted.

### 8.2.3 Limit

The delay between the application of the test signal and the start of the modulation shall have a nominal value of 10 ms and shall not exceed 15 ms, so that:

- the resulting number of bit errors is 0 or 1 in the case of the pseudo-random bit sequence;
- all three transmissions are correctly received in the case of the coded messages.

## 9 Measurement uncertainty

**Table 2: Absolute measurement uncertainties: maximum values**

Carrier sense delay	5 %
Receiver opening delay	1,5 ms
Other timings	5 %

## **Annex A (normative):      General arrangements for measurements involving the use of radiated fields**

The text in this annex is common to ETSs covering both audio and data radio equipment.

### **A.1    Test fixture**

#### **A.1.1    Description**

The test fixture is a RF coupling device associated with an integral antenna equipment for coupling the integral antenna to a 50  $\Omega$  RF terminal at the working frequencies of the equipment under test. This allows certain measurements to be performed using the conducted measurement methods. Only relative measurements may be performed, and only those at, or near, frequencies for which the test fixture has been calibrated.

In addition, the test fixture shall provide:

- a) a connection to an external power supply;
- b) an audio interface either by direct connection or by an acoustic coupler.

The test fixture normally shall be provided by the manufacturer.

The performance characteristics of the test fixture shall be approved by the testing authority and shall conform to the following basic parameters:

- a) the coupling loss shall not be greater than 30 dB;
- b) the coupling loss variation over the frequency range used in the measurement shall not exceed 2 dB;
- c) circuitry associated with the RF coupling shall contain no active or non linear devices;
- d) the Voltage Standing Wave Ratio (VSWR) at the 50  $\Omega$  socket shall not be greater than 1,5:1 over the frequency range of the measurements;
- e) the coupling loss shall be independent of the position of the test fixture and be unaffected by the proximity of surrounding objects or people. The coupling loss shall be reproducible when the equipment under test is removed and replaced;
- f) the coupling loss shall remain substantially constant when the environmental conditions are varied.

The characteristics and calibration shall be included in the test report.

#### **A.1.2    Calibration**

The calibration of the test fixture establishes a relationship between the output of the signal generator and the field strength applied to the equipment inside the test fixture.

The calibration is valid only at a given frequency and for a given polarisation of the reference field.

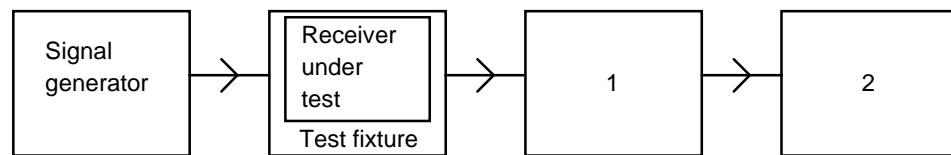

- 1) AF load/acoustic coupler;
- 2) distortion factor/audio level meter and psophometric filter.

**Figure A.1: Measuring arrangement for calibration**

The following procedure shall be followed:

- a) using the method described in ETS 300 390 [2], subclause 9.1, measure the sensitivity expressed as field strength, and note the value of this field strength in  $\text{dB}\mu\text{V}/\text{m}$  and the polarisation used;
- b) the receiver is now placed in the test fixture which is connected to the signal generator. The level of the signal generator producing a Signal to Noise and Distortion (SINAD) ratio of 20 dB shall be noted;
- c) the calibration of the test fixture is thus the linear relationship between the field strength in  $\text{dB}\mu\text{V}/\text{m}$  and the signal generator level in  $\text{dB}\mu\text{V}$  emf.

### A.1.3 Mode of use

The test fixture may be used to facilitate the measurements in clause 8 on equipment with an integral antenna.

To apply the specified wanted signal level expressed in field strength, convert it into the signal generator level (emf) using the calibration of the test fixture. This value shall be applied with the signal generator.

## A.2 Acoustic coupler

### A.2.1 General

When radiation measurements are performed, on the receiver, the audio output voltage should be conducted from the receiver to the measuring equipment, without perturbing the field near the receiver.

This perturbation can be minimised by using wires with high resistivity associated to a test equipment with a high input impedance, see clause A.3.

When this situation is not applicable, an acoustic coupler shall be used.

NOTE: When using an acoustic coupler, care should be exercised that possible ambient noise does not influence the test result.

### A.2.2 Description

The acoustic coupler shall comprise a plastic funnel, an acoustic pipe, and a microphone with a suitable amplifier.

The acoustic pipe shall be long enough (e.g. 2 m) to reach from the equipment under test to the microphone which is located in a position that will not disturb the RF field. The acoustic pipe shall have an inner diameter of about 6 mm and a wall thickness of about 1,5 mm and should be sufficiently flexible to allow the platform to rotate.

The plastic funnel shall have a diameter appropriate to the size of the loudspeaker in the equipment under test, with soft foam rubber glued to its edge, it shall be fitted to one end of the acoustic pipe and the microphone shall be fitted to the other end. It is very important to fix the centre of the funnel in a reproducible position relative to the equipment under test, since the position of the centre has a strong influence on the frequency response that will be measured. This can be achieved by placing the

equipment in a close fitting acoustic mounting jig, supplied by the manufacturer, of which the funnel is an integral part.

The microphone shall have a response characteristic flat within 1 dB over a frequency range of 50 Hz to 20 kHz, a linear dynamic range of at least 50 dB. The sensitivity of the microphone and the receiver audio output level shall be suitable to measure a signal to noise ratio of at least 40 dB at the nominal audio output level of the equipment under test. Its size should be sufficiently small to couple to the acoustic pipe.

The frequency correcting network shall correct the frequency response of the acoustic coupler so that the acoustic SINAD measurement is valid, see clause A.3.

### A.2.3 Calibration

The aim of the calibration of the acoustic coupler is to determine the acoustic SINAD ratio which is equivalent to the SINAD ratio at the receiver output.

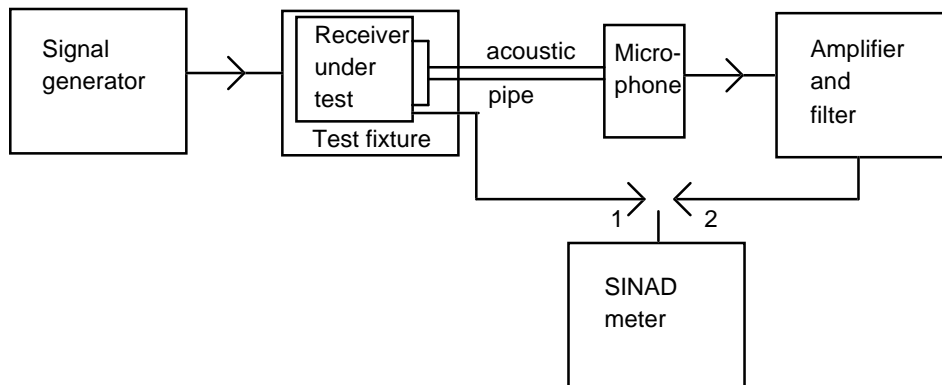

Figure A.2: Measuring arrangement for calibration

- a) An acoustic coupler shall be mounted to the equipment, if necessary using a test fixture. A direct electrical connection to the terminals of the output transducer shall be made. A signal generator shall be connected to the receiver input (or to the test fixture input). The signal generator shall be at the nominal frequency of the receiver and shall be modulated by the normal test modulation.
- b) Where possible, the receiver volume control shall be adjusted to give at least 50 % of the rated audio output power and, in the case of stepped volume controls, to the first step that provides an output power of at least 50 % of the rated audio output power.
- c) The test signal input level shall be reduced until an electrical SINAD ratio of 20 dB is obtained, the connection being in position 1. The signal input level shall be recorded.
- d) With the same signal input level, the acoustic equivalent SINAD ratio shall be measured and recorded, the connection being in position 2.
- e) Steps c) and d) above shall be repeated for an electrical SINAD ratio of 14 dB, and the acoustic equivalent SINAD ratio measured and recorded.

### A.3 Bibliography

- IEC Publication 489-3 Second edition (1988) Appendix F pages 130 to 133.

## **Annex B (informative): Comments concerning the random part of the observation time**

The random part  $t_r$  is a randomly selected time ( $n \times t_j$ ) out of a certain number of possible time slots. The actual number of possible time slots depends on the actual traffic load of the radio channel.

With every first trial to access the radio channel it is assumed that the traffic load is low. Therefore the number of possible time slots to choose from is set to  $m = 4$ .

When a retransmission is required, e.g. when no acknowledge is received, it is assumed that the message has collided with another radio transmission, which is an indication that the actual traffic load has increased. Therefore all active data transmitters which have not received an acknowledge have to double the number of possible time slots ( $m$ ) to 8.

If after the repetition of the transmission, another repetition is required, e.g. when no acknowledge has been received, the number of possible time slots ( $m$ ) is doubled again. So the random part of the new observation time is now selected out of 16 possible time slots.

The number of possible time slots ( $m$ ) can be increased up to 64, which makes the chance of a collision of different messages extremely low.

After a successful transmission, e.g. when an acknowledge has been received, the number of possible time slots for the equipment is reset to 4.

For the first trial the observation time  $t_0 = t_f + n \times t_j$ .

$n =$  a random number between 1 to 4.

For the second trial the random number  $n$  is between 1 to 8.

If the fourth trial is also unsuccessful then the random number will be between 1 to 64 for the fifth trial.

**Annex C (informative): Comments concerning the traffic loading of shared channels**

It can be expected that, with (existing) speech users having priority over their data counterparts, the waiting time for data users using this protocol will increase rapidly with increasing speech traffic load.

Therefore, this access protocol is not suitable for use with channels having a speech traffic of more than 0,2 erlang in the busy hour. The extra traffic generated by data transmissions should not be expected to exceed an additional traffic of 0,05 erlang.



## History

Document history			
January 1995	Public Enquiry	PE 78:	1995-01-30 to 1995-05-26
September 1995	Vote	V 87:	1995-09-11 to 1995-11-03
December 1995	First Edition		
March 1996	Converted into Adobe Acrobat Portable Document Format (PDF)		