



EUROPEAN
TELECOMMUNICATION
STANDARD

ETS 300 467

March 1998

Source: NA

Reference: DE/NA-053204

ICS: 33.020

Key words: Broadband, frame relay, interworking, ISDN, B-ISDN, frame mode, Bearer

**Broadband Integrated Services Digital Network (B-ISDN);
Support of Frame Relay Bearer Service (FRBS) in B-ISDN and
frame relay interworking between B-ISDN and other networks**

ETSI

European Telecommunications Standards Institute

ETSI Secretariat

Postal address: F-06921 Sophia Antipolis CEDEX - FRANCE

Office address: 650 Route des Lucioles - Sophia Antipolis - Valbonne - FRANCE

Internet: secretariat@etsi.fr - <http://www.etsi.fr> - <http://www.etsi.org>

Tel.: +33 4 92 94 42 00 - Fax: +33 4 93 65 47 16

Copyright Notification: No part may be reproduced except as authorized by written permission. The copyright and the foregoing restriction extend to reproduction in all media.

© European Telecommunications Standards Institute 1998. All rights reserved.

Contents

Foreword	5
1 Scope	7
2 Normative references	7
3 Abbreviations.....	8
4 Service description	10
4.1 Functional architecture.....	10
4.1.1 FRBS provided by FRSF inside B-ISDN	10
4.1.2 FRBS provided by FRSF outside B-ISDN, accessed via ATM bearer capabilities.....	11
4.1.3 Frame relay protocol support via ATM bearer capabilities	12
5 Interfaces and protocols.....	13
5.1 Frame Relay B-ISDN Access Interface (FR-BAI)	13
5.1.1 Physical Layer	14
5.1.2 ATM layer	14
5.1.3 AAL.....	14
5.1.3.1 AAL5 SAR and CPCS.....	14
5.1.3.2 FR-SSCS	14
5.2 Frame relay B-ISDN Network-to-Network Interface (FR-BNNI)	14
5.2.1 Physical Layer (PL)	15
5.2.2 ATM layer	15
5.2.3 AAL.....	15
5.2.3.1 AAL5 SAR and CPCS.....	15
5.2.3.2 FR-SSCS	15
5.3 FR-SSCS	15
5.3.1 Service provided by FR-SSCS	15
5.3.1.1 Primitives	16
5.3.1.2 Description of connections	17
5.3.2 Interaction with the management and control plane.....	17
5.3.3 Functions, structure and coding of FR-SSCS	17
5.3.3.1 Functions in FR-SSCS.....	17
5.3.3.2 FR-SSCS-PDU structure and coding	18
5.3.4 Procedures for the FR-SSCS	18
5.3.4.1 State variable.....	18
5.3.4.2 Procedures at the sender side.....	18
5.3.4.3 Procedures at the receiver side.....	19
5.3.4.4 Summary of parameters and values on the FR-SSCS connections.....	21
5.3.5 Frame Relay Permanent Virtual Connection (FR-PVC) monitoring	21
5.4 Multiplexing of FRBS connections over B-ISDN	22
5.5 Congestion management strategy	23
Annex A (normative): Additional procedures for Frame Relay Permanent Virtual Connections (FR PVCs) for the carriage on ATM using unnumbered information frame	24
History.....	25

Blank page

Foreword

This European Telecommunication Standard (ETS) has been produced by the Network Aspects (NA) Technical Committee of the European Telecommunications Standards Institute (ETSI).

This European Telecommunication Standard (ETS) defines the B-ISDN architectural configuration for providing the FRBS service.

Transposition dates	
Date of adoption of this ETS:	20 February 1998
Date of latest announcement of this ETS (doa):	30 June 1998
Date of latest publication of new National Standard or endorsement of this ETS (dop/e):	31 December 1998
Date of withdrawal of any conflicting National Standard (dow):	31 December 1998

Blank page

1 Scope

This ETS defines the Broadband Integrated Services Digital Network (B-ISDN) architectural configuration for providing the Frame Relay Bearer Service (FRBS) service.

B-ISDN FRBS is defined in ETS 300 399-1 [5] and ETS 300 399-4 [8].

This ETS specifies service specific convergence sublayer of AAL type 5 and its use for B-ISDN FRBS.

The B-ISDN FRBS belongs is a connection-oriented, variable bit rate, non assured operation broadband services with no timing relation between the sender and receiver.

This ETS also describes the network interworking between B-ISDNs supporting FRBS and other ISDNs and Public Data Networks (PDNs) supporting FRBS as defined in ETS 300 399-1 [5], ETS 300 399-2 [6] and ETS 300 399-3 [7].

It describes also access configurations to networks supporting FRBS or FRDTS.

This ETS defines only the U-plane procedures for FRBS supported on Permanent Virtual Connections (PVCs).

2 Normative references

This ETS incorporates by dated and undated reference, provisions from other publications. These normative references are cited at the appropriate places in the text and the publications are listed hereafter. For dated references, subsequent amendments to or revisions of any of these publications apply to this ETS only when incorporated in it by amendment or revision. For undated references the latest edition of the publication referred to applies.

- [1] ETS 300 298-2: "Broadband Integrated Services Digital Network (B-ISDN); Asynchronous Transfer Mode (ATM); Part 2: B-ISDN ATM layer specification [ITU-T Recommendation I.361 (1995)]".
- [2] ETS 300 299: "Broadband Integrated Services Digital Network (B-ISDN); Cell based user network access for 155 520 kbit/s and 622 080 kbit/s; Physical layer interfaces for B-ISDN applications".
- [3] ETS 300 300: "Broadband Integrated Services Digital Network (B-ISDN); Synchronous Digital Hierarchy (SDH) based user network access; Physical layer User Network Interfaces (UNI) for 155 520 kbit/s and 622 080 kbit/s Asynchronous Transfer Mode (ATM) B-ISDN applications".
- [4] ETS 300 337: "Transmission and Multiplexing (TM); Generic frame structures for the transport of various signals (including Asynchronous Transfer Mode (ATM) cells and Synchronous Digital Hierarchy (SDH) elements) at the ITU-T Recommendation G.702 hierarchical rates of 2 048 kbit/s, 34 368 kbit/s and 139 264 kbit/s".
- [5] ETS 300 399-1: "Frame relay services; Part 1: General description".
- [6] ETS 300 399-2: "Frame relay services; Part 2: Integrated Services Digital Network (ISDN); Frame relay bearer service; Service definition".
- [7] ETS 300 399-3: "Frame relay services; Part 3: Frame relay data transmission service; Service definition".
- [8] ETS 300 399-4: "Frame relay services; Part 4: Broadband Integrated Services Digital Network (B-ISDN); Frame relay bearer service; Service definition".
- [9] ETS 300 428: "Broadband Integrated Services Digital Network (B-ISDN); Asynchronous Transfer Mode (ATM) Adaptation Layer (AAL) specification - type 5".

- [10] ETS 300 455-1: "Broadband Integrated Services Digital Network (B-ISDN); Broadband Virtual Path Service (BVPS); Part 1: BVPS for Permanent communications (BVPS-P)".
- [11] ETS 300 455-2: "Broadband Integrated Services Digital Network (B-ISDN); Broadband Virtual Path Service (BVPS); Part 2: BVPS for Reserved communications (BVPS-R)".
- [12] ITU-T Recommendation F.811 (1993): "Broadband connection-oriented bearer service".
- [13] ITU-T Recommendation G.804 (1994): "ATM cell mapping into plesiochronous digital hierarchy (PDH)".
- [14] ITU-T Recommendation G.832 (1994): "Transport of SDH elements on PDH networks - Frame and multiplexing structures".
- [15] CCITT Recommendation I.233.1 (1992): "ISDN frame relaying bearer service".
- [16] ITU-T Recommendation I.363 (1994): "B-ISDN ATM Adaptation Layer (AAL) specification".
- [17] ITU-T Recommendation I.365.1 (1994): "Frame relaying service specific convergence sublayer (FR-SSCS)".
- [18] CCITT Recommendation I.370 (1992): "Congestion management for the ISDN frame relaying bearer service".
- [19] ETS 300 301, Edition 2 (1997): "Broadband Integrated Services Digital Network (B-ISDN); Traffic control and congestion control in B-ISDN [ITU-T Recommendation I.371 (1996)]".
- [20] ITU-T Recommendation I.372 (1993): "Frame relaying bearer service network-to-network interface requirements".
- [21] ITU-T Recommendation I.555 (1994): "Frame relaying bearer service interworking".
- [22] CCITT Recommendation Q.922 (1992): "ISDN data link layer specification for frame mode bearer services".
- [23] ITU-T Recommendation Q.933 (1994): "Digital Subscriber Signalling System No.1 (DSS1) - Signalling specification for frame mode basic call control".
- [24] ITU-T Recommendation I.327 (1993): "B-ISDN functional architecture".

3 Abbreviations

For the purposes of this ETS, the following abbreviations apply:

AAL	ATM Adaptation Layer
AAL5	AAL type 5
ATM	Asynchronous Transfer Mode
ATM-VCC	Asynchronous Transfer Mode-Virtual Circuit Connection
B-ISDN	Broadband Integrated Services Digital Network
B-TE	B-ISDN Terminal
BECN	Backward Explicit Congestion Notification
BVPS	Broadband Virtual Path Service
C/R	Command/Response bit
CBR	Constant Bit Rate
CEB	Congestion Encountered Backward
CEF	Congestion Encountered Forward

CI	Congestion Indication
CPCS	Common Part Convergence Sublayer
CPCS-CI	CPCS - Congestion Indication
CPCS-LP	CPCS - Loss Priority
CPCS-UU	CPCS - User-to-User Indication
D/C	DLCI or DL-CORE control indicator
DE	Discard Eligibility
DLCI	Data Link Connection Identifier
DSS1	Digital Subscriber Signalling N°1
DTE	Data Terminal Equipment
EA	Address Extension bit
FCS	Frame Check Sequence
FECN	Forward Explicit Congestion Notification
FR	Frame Relay
FR-BNNI	Frame Relay Broadband Network-to-Network Interface
FR-IWP	Frame Relay Interworking Point
FR-SSCS	Frame Relay Service Specific Convergence Sublayer
FR-BAI	Frame Relay Broadband Access Interface
FR-IAI	Frame Relay ISDN Access Interface
FR-INNI	Frame Relay ISDN Network to Network Interface
FR-PAI	Frame Relay Private Access Interface
FR-PNNI	Frame Relay Private Network to Network Interface
FRBS	Frame Relay Bearer Service
FRDTS	Frame Relay Data Transmission Service
FRSF	Frame Relay Service Function
ID	Interface Data
ISDN	Integrated Service Digital Network
IWF	Interworking Function
LME	Layer Management Entity
LSB	Least Significant Bit
MSB	Most Significant Bit
NNI	Network Node Interface
PCI	Protocol Control Information
PDH	Plesiochronous Digital Hierarchy
PDN	Public Data Network
PDU	Protocol Data Unit
PHY	Physical layer
PISN	Private Integrated Service Network
PVC	Permanent Virtual Connection
SAP	Service Access Point
SAR	Segmentation and Reassembly Sublayer
SDH	Synchronous Digital Hierarchy
SDU	Service Data Unit
SSCS	Service Specific Convergence Sublayer
TE	Terminal Equipment
UNI	User Network Interface
UPC	Usage Parameter Control
VBR	Variable Bit Rate
VC	Virtual Channel
VCC	Virtual Channel Connection
VCI	Virtual Channel Identifier
VP	Virtual Path
VPC	Virtual Path Connection
VPI	Virtual Path Identifier

4 Service description

This description of FRBS in B-ISDN is in accordance with:

- ITU-T Recommendation F.811 [12], which provides a service description of a broadband connection oriented bearer service. ITU-T Recommendation F.811 [12] includes the following service subcategories:
 - sub-category A: Constant Bit Rate (CBR);
 - sub-category B: Variable Bit Rate (VBR) with timing;
 - sub-category C: VBR without timing:
 - C1: emulation of packet mode bearer services;
 - C2: emulation of frame mode bearer services;
 - C3: others.
 - sub-category X: Asynchronous Transfer Mode (ATM) Adaptation Layer (AAL) defined by user;
- ETS 300 399-2 [6], which defines ISDN FRBS;
- ETS 300 399-1 [5];
- ETS 300 399-4 [8].

4.1 Functional architecture

B-ISDN is capable of supporting data transfer between B-ISDN customers based on frame relay transfer techniques. The B-ISDN configuration is in line with the functional architecture defined in ITU-T Recommendation I.327 [24]. It need not directly imply frame relay methods implemented within B-ISDN. In the B-ISDN, virtual channels are established at the ATM layer by means of the connection oriented technique. The frame relay protocol can be supported in the U-plane using the B-ISDN in the following three ways:

- a) FRBS provided by Frame Relay Service Function (FRSF) inside B-ISDN;
- b) FRBS provided by FRSF outside B-ISDN, accessed via ATM bearer capabilities;
- c) frame relay protocol support via ATM bearer capabilities.

In all cases the protocol stack implemented in B-ISDN customer equipment is identical as shown in figures 1, 2 and 3. The management and control plane functions which need to be provided in the network in all cases are for further study. The three cases are outlined in the following paragraphs.

4.1.1 FRBS provided by FRSF inside B-ISDN

In this case the FRSF is provided within the B-ISDN. The FRSF handles frame relay protocols and routes data according to routing information provided during frame relay connection establishment. This case is illustrated in figures 1a and 1b.

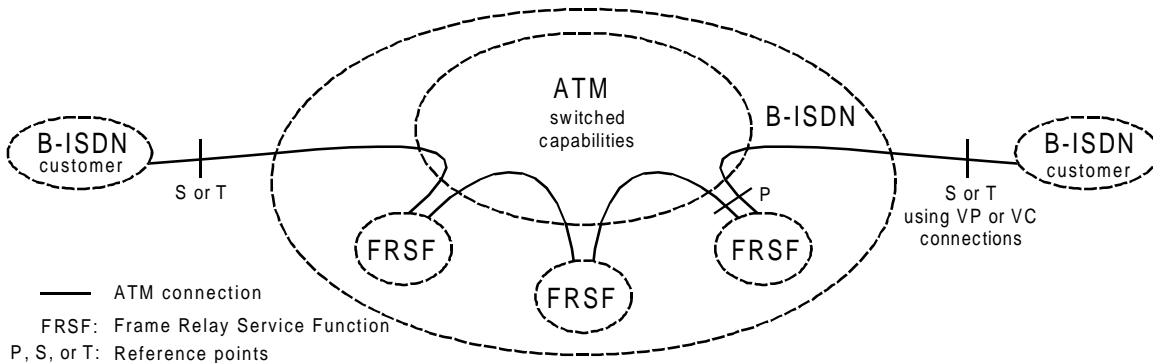
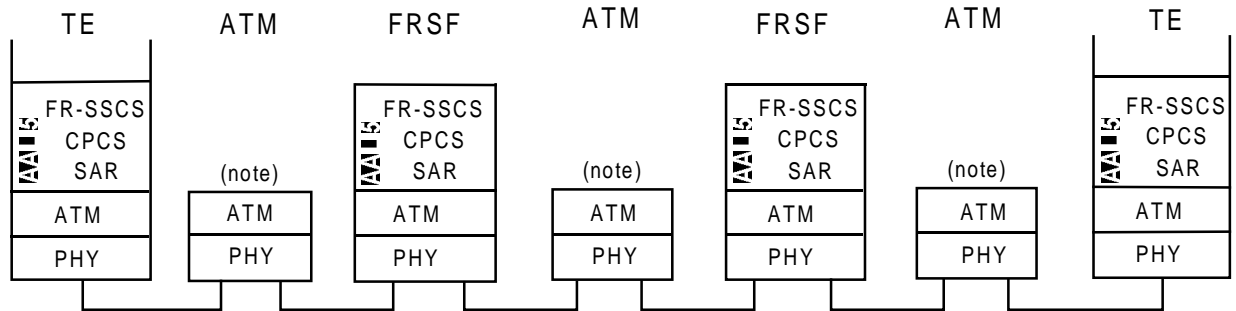

Figure 1a: FRBS provided by FRSF inside B-ISDN



NOTE: The ATM switching capabilities can be integrated with FRSF.

Figure 1 b: Protocol stack of FRBS provided by FRSF inside B-ISDN

The statistical multiplexing can be done at the frame level. In this case the bearer capabilities required from the ATM network can be met by those provided by the Virtual Path (VP) bearer service already defined in ETS 300 455 [11], with peak bandwidth allocation. Virtual Channel (VC) bearer capabilities may also be deployed and the way of mapping the frame relay parameters into ATM transfer capabilities (e.g. for statistical multiplexing at the ATM layer) is for further study.

4.1.2 FRBS provided by FRSF outside B-ISDN, accessed via ATM bearer capabilities

In this case a transparent connection of the ATM layer, is used between B-ISDN interfaces (at reference points S_B/T_B or M). Frame relay protocols operating on and above the adaptation layer are transparent to the B-ISDN. The frame relay service and adaptation layer functions are implemented outside the B-ISDN. This case is illustrated in figures 2a and 2b.

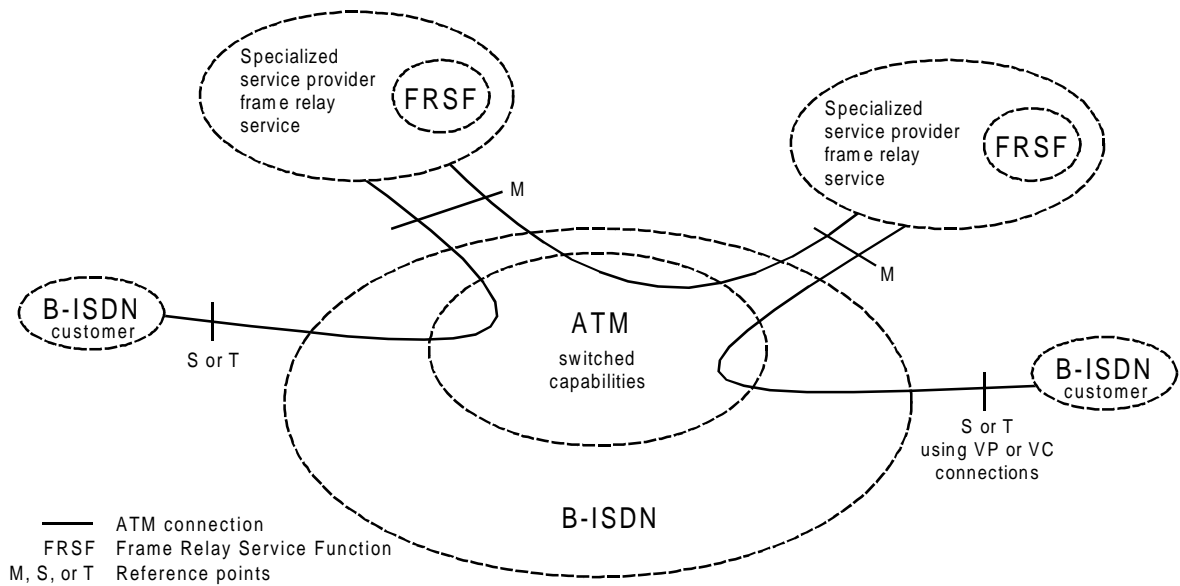

Figure 2a: FRBS provided by FRSF outside B-ISDN

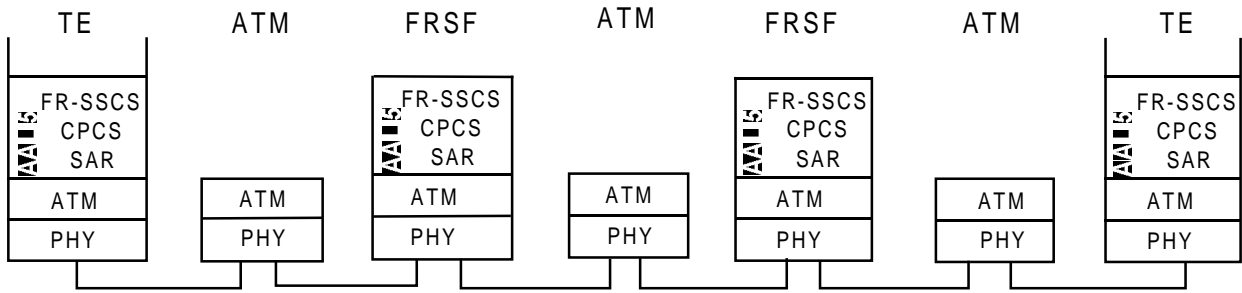

Figure 2b: Protocol stack of FRBS provided by FRSF outside B-ISDN

The requirements on the ATM layer are the same as in subclause 4.1.1.

4.1.3 Frame relay protocol support via ATM bearer capabilities

A frame relay protocol may also be carried by ATM bearer capabilities as shown in figures 3a and 3b. In this case a transparent connection of the ATM layer, is used between B-ISDN UNIs (at reference point S_B/T_B). Frame relay protocols operating on and above the adaptation layer are transparent to the B-ISDN and they are implemented in the Terminal Equipments (TEs) at B-ISDN UNIs.

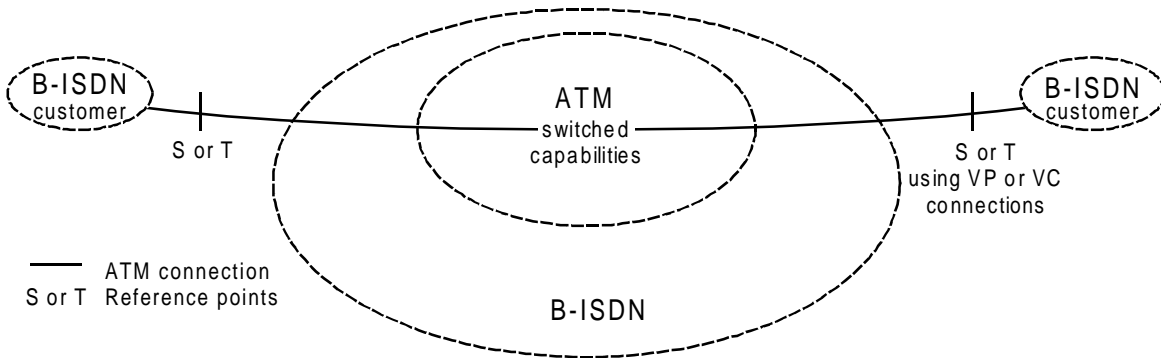

Figure 3a: A frame relay protocol carried by an ATM bearer service

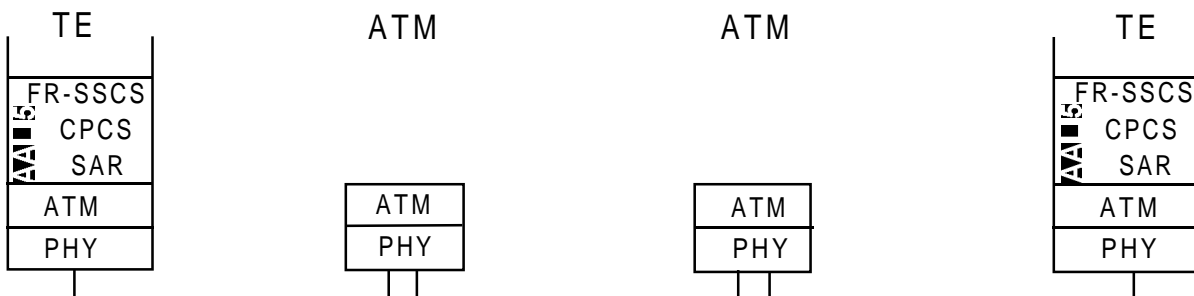

Figure 3b: Protocol stack of frame relay protocol carried by an ATM bearer service

The switching and statistical multiplexing is done at the ATM level. The preliminary list of requirements for the used bearer service is as follows:

- Virtual Channel Identifier (VCI) based switching;
- isolation between connections: e.g. usage parameter control, network parameter control;
- delay and delay variation adapted to data applications;
- network congestion: the random discarding of cells can badly impact the frame loss rate. This impact may be reduced by taking frame boundaries (reflected in the value of the AUU bit in the ATM cell header) into account when taking discarding decisions;
- a minimum bandwidth requirement per connection has to be met.

NOTE: Optional multiplexing at the frame level is transparent to the B-ISDN.

5 Interfaces and protocols

5.1 Frame Relay B-ISDN Access Interface (FR-BAI)

Frame relay direct provision is performed through the use of specialized network functions (FRSF). User equipment may have direct access to the equipment realizing FRSF at the S_B/T_B reference points. The protocol stack includes the UNI physical and ATM layer both in the user equipment on one side of the FR-BAI and in the network equipment realizing FRSF on the other side. Usage Parameter Control (UPC) functions, as foreseen for ATM user access, are performed on the network side of the FR-BAI.

Indirect user access to the FRSF through one or more ATM nodes is also possible. In this case the interface between the user equipment and the adjacent ATM node is defined at the S_B/T_B reference points, while that between the equipment realizing the FRSF and the adjacent ATM node(s) is defined at the P/M reference points.

At the S_B/T_B reference points, the physical and ATM layer of the FR-BAI stack are terminated in the user equipment and the ATM node(s). They are based on the ATM UNI. UPC functions as foreseen for ATM user access are performed by the ATM network elements at the network side of the UNI.

At the P/M reference points, the physical and ATM layer of the FR-BAI stack are terminated in the equipment realizing FRSF and the ATM node(s) and are based on the ATM Network Node Interface (NNI).

The functions performed by the frame relay specific layer (AAL 5 SAR, CPCS and Frame Relay Service Specific Convergence Sublayer (FR-SSCS)) are the same both in the direct and indirect access cases. The protocol stack for the direct and indirect access is shown in figure 4. The FR-SSCS protocol functions and elements are defined in subclause 5.3.

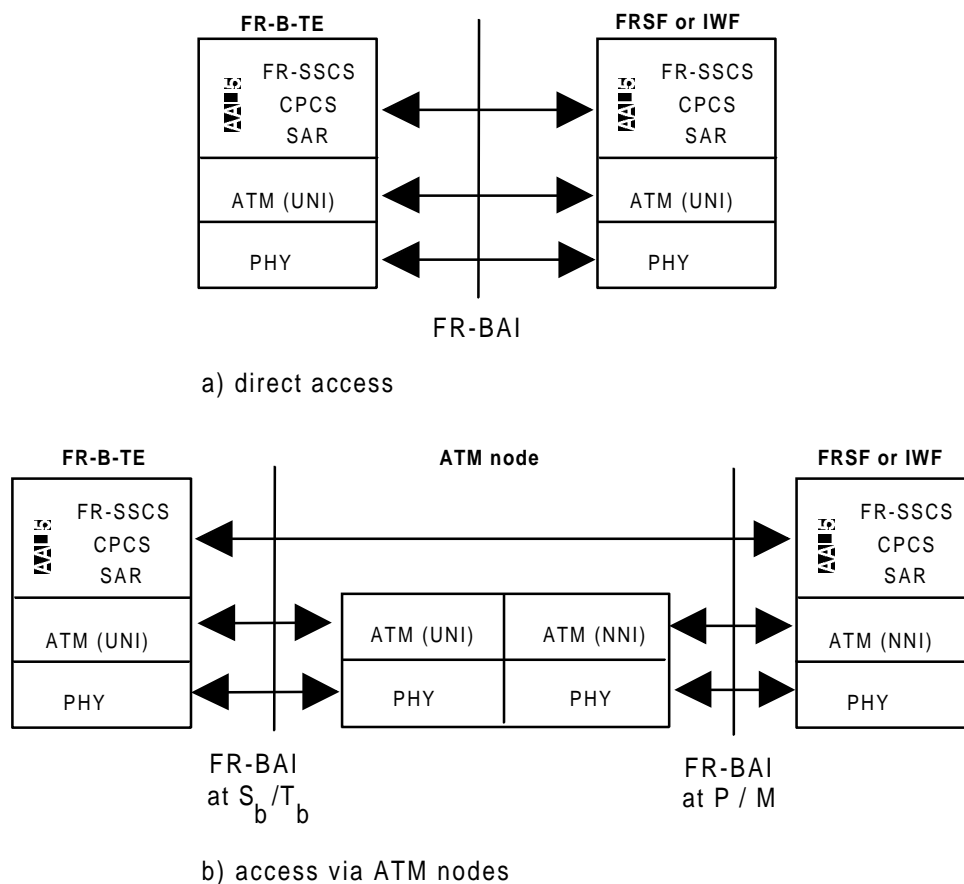

Figure 4: Frame Relay Broadband Access Interface (FR-BAI) U-plane protocol reference architecture

5.1.1 Physical Layer

All B-ISDN physical layer specifications are applicable (including ETS 300 300 [3] and ETS 300 299 [2], ETS 300 337 [4], ITU-T Recommendations G.804 [13] and G.832 [14]).

5.1.2 ATM layer

As defined in ETS 300 298-2 [1].

5.1.3 AAL

5.1.3.1 AAL5 SAR and CPCS

As defined in ETS 300 428 [9].

5.1.3.2 FR-SSCS

As defined in subclause 5.3.

5.2 Frame relay B-ISDN Network-to-Network Interface (FR-BNNI)

The FR-BNNI supports frame relay service provision, allowing transfer of frame relay service data units within the ATM network.

The FR-BNNI protocol stack is based on the ATM Network Node Interface (NNI).

Equipment realizing the FR-BNNI stack may be connected directly. Indirect linking through one or more ATM nodes is also possible.

The U-plane protocol reference architecture for the FR-BNNI is given in figure 5.

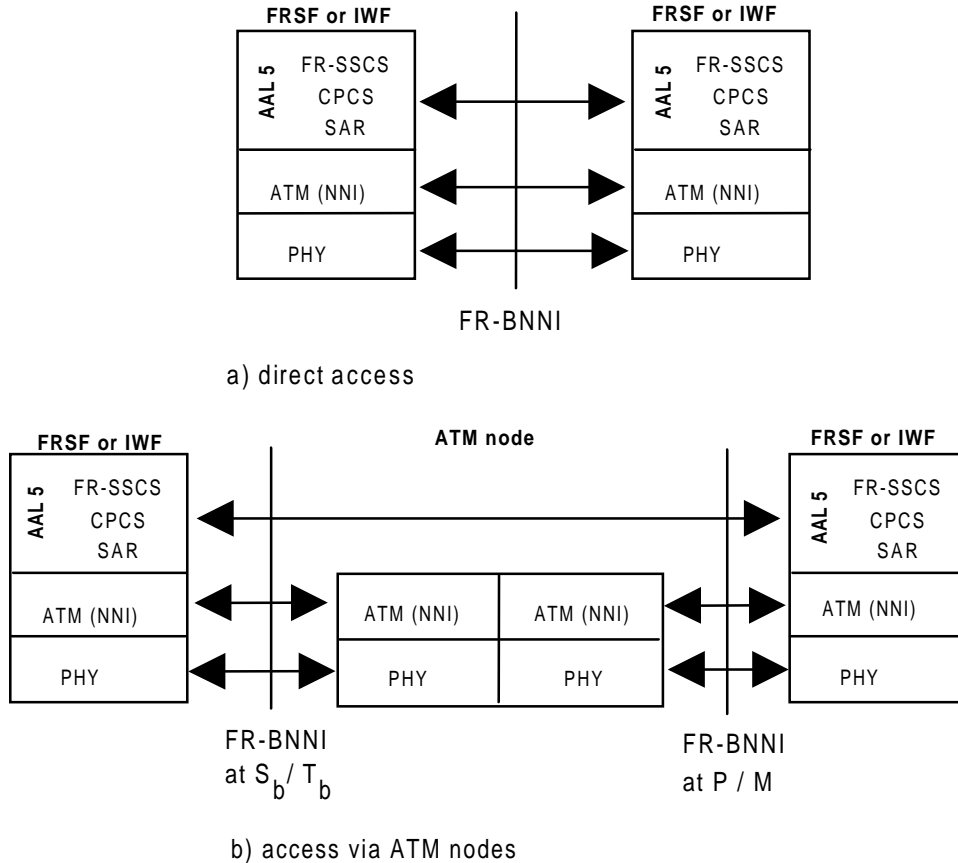

Figure 5: FR-BNNI U-plane protocol reference architecture

5.2.1 Physical Layer (PL)

All B-ISDN physical layer specifications are applicable (including ETS 300 300 [3] and ETS 300 299 [2], ETS 300 337 [4], ITU-T Recommendations G.804 [13] and G.832 [14]).

5.2.2 ATM layer

As defined in ETS 300 298-2 [1].

5.2.3 AAL

5.2.3.1 AAL5 SAR and CPCS

As defined in ETS 300 428 [9].

5.2.3.2 FR-SSCS

As defined in subclause 5.3.

5.3 FR-SSCS

NOTE: This subclause is in line with ITU-T Recommendation I.365.1 [17], but they are not exactly the same.

The FR-SSCS is located in the upper part of the AAL on top of the Common Part Convergence Sublayer (CPCS) of AAL type 5, as specified ETS 300 428 [9], clause 6 and shown in figures 6 and 7. The FR-SSCS is used at the B-TE to emulate the FRBS in B-ISDN. It is also used for interworking between a B-ISDN and a frame relay network.

5.3.1 Service provided by FR-SSCS

At the DL-CORE-SAP the FR-SSCS provides the core service as described in ETS 300 399-1[5], annex C. The core service primitives, exchanged between the core service user and the core service provider (FR-SSCS) are summarized in table 1 according to the table contained in CCITT Recommendation Q.922 [22], subclause A.4.2.2. The primitives and their parameters are described in detail in [5], annex C (see figure 6).

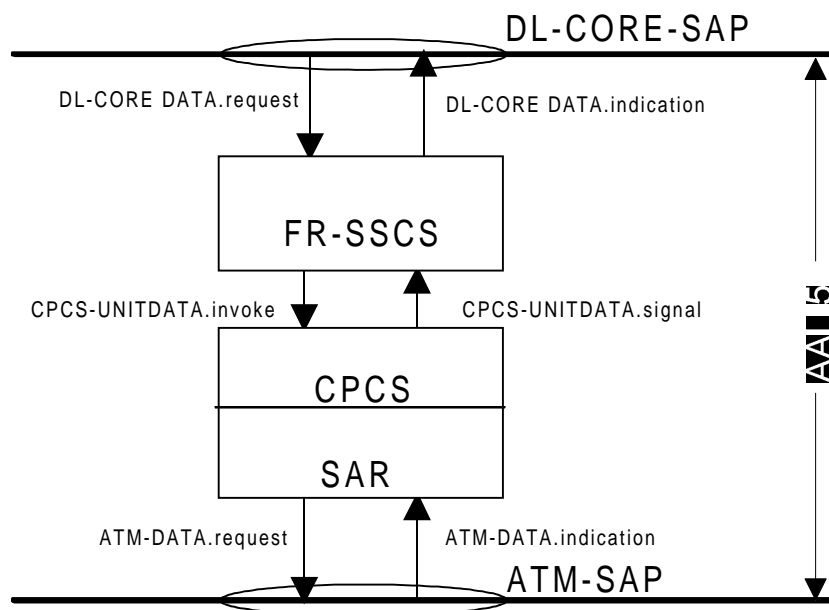

Figure 6: Location of the FR-SSCS in the B-ISDN protocol reference model for a B-TE

The exchange of information at the Frame Relay Interworking Point (FR-IWP) is described by IWF-DATA.indication and IWF-DATA.request primitives (see figure 7). The parameters of those primitives are contained in table 2.

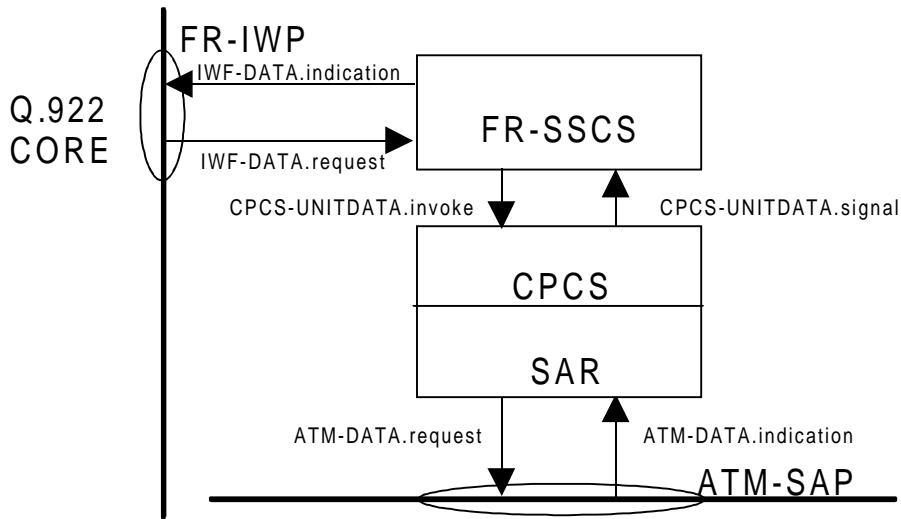

Figure 7: Location of the FR-SSCS in the B-ISDN protocol reference model for the IWF between a frame relay network and a B-ISDN

In the case of a FRSF, figure 7 applies with the following modification: the FR-IWP does not lead to Q.222 core, but to the same protocol stack as shown at the right hand side of the figure.

The FR-SSCS preserves the FR-SSCS-SDU sequence integrity. It uses the CPCS message mode service without the corrupted data delivery option.

5.3.1.1 Primitives

The primitives exchanged across the DL-CORE-SAP are described in table 1.

Table 1: Core service primitives and parameters at the DL-CORE-SAP

Primitive Parameter (note)	DL-CORE DATA. request	DL-CORE DATA. indication	FR-SSCS-PDU field
DL-CORE user data	X	X	Information field
Discard Eligibility (DE)	X		DE
CEB		X	BECN
CEF		X	FECN
DL-CORE-Service-User protocol control information	X	X	C/R bit
X: parameter is present			
NOTE: Whether the DL-CORE control parameter and the DLCI or DL-CORE control indicator parameter are included in the DL-CORE DATA primitives is for further study.			

The primitives exchanged across the FR-IWP are described in table 2.

Table 2: Primitives and parameters at the FR-IWP

Parameter	Primitive	IWF-DATA. request	IWF DATA. indication	FR-SSCS-PDU field
DL-CORE user data		X	X	Information field
DEI		X	X	DE
CEB		X	X	BECN
CEF		X	X	FECN
DL-CORE-Service-User protocol control information		X	X	C/R bit
DLCI or DL-CORE control indicator (note 1)		X	X	D/C
DL-CORE control (note 2)		X	X	DL-CORE control
X: parameter is present				
NOTE 1: If this parameter is set = C it indicates the existence of the DL-CORE control parameter.				
NOTE 2: This parameter only exists as indicated by the DLCI or DL-CORE control indicator parameter.				

The primitives exchanged across the boundary between the FR-SSCS and the CPCS of AAL type 5 are described in ITU-T Recommendation ETS 300 428 [9].

5.3.1.2 Description of connections

Multiple FR-SSCS connections may be associated with a single CPCS connection (and with the corresponding ATM connection), allowing multiplexing at the FR-SSCS. Within a CPCS connection the FR-SSCS connections are uniquely identified by the Data Link Connection Identifiers (DLCIs).

5.3.2 Interaction with the management and control plane

For further study.

5.3.3 Functions, structure and coding of FR-SSCS

5.3.3.1 Functions in FR-SSCS

The functions provided by the FR-SSCS include:

a) Multiplexing/demultiplexing

This function provides the capability to multiplex multiple FR-SSCS connections into a single CPCS connection.

b) Inspection of the FR-SSCS-PDU length

These functions inspect the FR-SSCS-PDU to ensure that it consists of an integral number of octets and to ensure that it is neither too long nor too short as specified in ETS 300 399-1[5].

c) Congestion control

These functions provide the means for the network to notify the end user, in forward and backward direction, that congestion avoidance procedures should be initiated, where applicable (congestion control forward and congestion control backward). In addition the functions provide the means for the end user and/or the network to indicate what frames should be discarded in preference to other frames in a congestion situation (congestion control discard eligibility). Congestion management procedures are described in CCITT Recommendation I.370 [18].

5.3.3.2 FR-SSCS-PDU structure and coding

The peer-to-peer communication between FR-SSCS entities uses FR-SSCS-PDUs. The format of the FR-SSCS-PDU structure is shown in figure 8. The details of the formats and the coding of the fields are given in CCITT Recommendation Q.922 [22], clause A.3.

NOTE: The structure is exactly the same as the CCITT Recommendation Q.922 [22] frame relay frame without the flags, zero bit insertion and FCS.

As every octet of an ATM-PDU is defined to be transmitted from the Most Significant Bit (MSB) to the Least Significant Bit (LSB), the FR-SSCS-PDU in the ATM-PDU is also to be transmitted from MSB to LSB. Though this bit transmission order is different from that of CCITT Recommendation Q.922 [22], the user of the FR-SSCS should regard the transmission order of the FR-SSCS to be the same as CCITT Recommendation Q.922 [22], as the original bit order is restored after receipt.

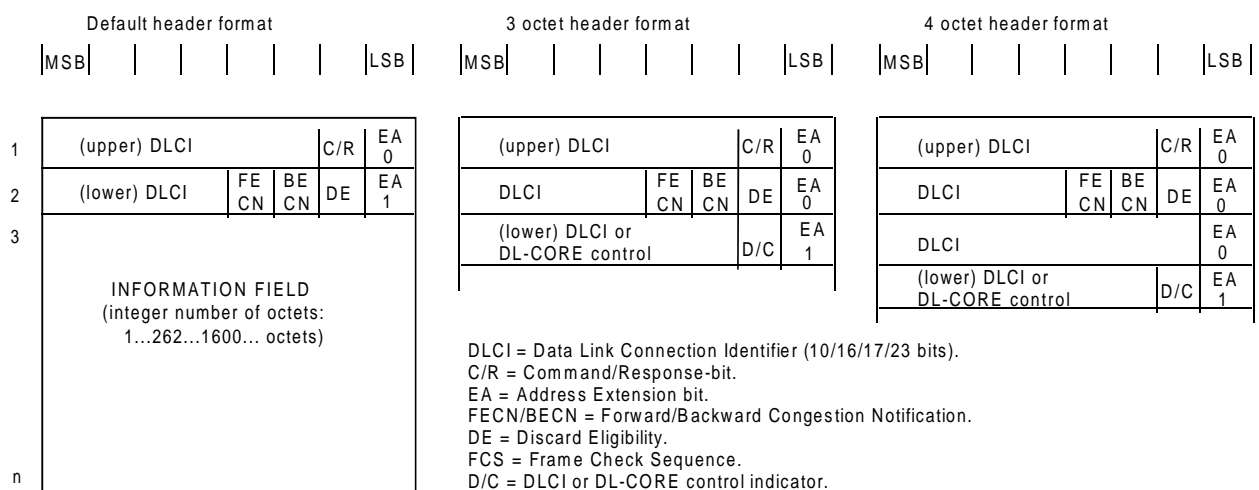

Figure 8: Structure of FR-SSCS-PDU with 2, 3 and 4 octet header formats

The support of the default (2 octet) header format is mandatory. The support of 3 and 4 octet header formats is optional.

5.3.4 Procedures for the FR-SSCS

5.3.4.1 State variable

Most_recent_CI_received:

This variable is initialized to "0". This variable records the value of the CPCS-CI parameter of the most recent CPCS-UNITDATA.signal primitive received for this CPCS connection in the reverse direction.

5.3.4.2 Procedures at the sender side

When FR-SSCS receives:

- a DL-CORE DATA.request from the core service user in a B-TE; or
- a IWF-DATA.request from the CCITT Recommendation Q.922 [22] core in a IWF,

it shall construct the FR-SSCS-PDU as specified in table 3, according to the format in figure 8.

Table 3: Values for the FR-SSCS-PDU at the sender side

FR-SSCS-PDU FIELD	VALUE set by the FR-SSCS	
	in B-TE	in IWF or in FRSF
DLCI	is set to the value which is associated to the FR-SSCS connection during the connection set-up or at the subscription	(as in B-TE)
C/R	is set to the value of the parameter DL-CORE-Service-User protocol control information	(as in B-TE)
FECN	is set to "0"	is set to the value of the parameter CEF. It may also be set in case of internal congestion of the equipment.
BECN	is set to "0" or optionally to the value of the variable Most_recent_CI_received (see note)	is set to logical OR of the values of the variable Most_recent_CI_received and the parameter CEB. It may also be set in case of internal congestion of the equipment.
DE	is set to the value of the parameter DE	(as in B-TE)
DL-CORE control	for further study	(as in B-TE)
D/C	is set to indicate whether the last header octet is negotiated during the connection set-up or at subscription to contain DLCI bits ("0") or the DL-CORE control field ("1") ?	(as in B-TE)
EA	is set to "0" at the first octet(s) of the header and to "1" at the last octet of the header	(as in B-TE)
Information field	is set to the value of the parameter DL-CORE user data	(as in B-TE)
NOTE: The BECN setting is a terminal option.		

The FR-SSCS-PDU is then forwarded to the CPCS sublayer in the Interface Data (ID) parameter of the CPCS-UNITDATA.invoke primitive. Other parameters of that primitive are set as follows:

- the CPCS Loss Priority (CPCS-LP) parameter is either:
 - case a) set to the value of the parameter DE of the DL-CORE DATA.request primitive or the IWF-DATA.request primitive; or
 - case b) always set to "0";
 - case c) always set to "1".

All options above shall be supported, so that it can be negotiated at connection set-up or subscription on a CPCS connection by CPCS connection basis which one is used;

- the CPCS Congestion Indication (CPCS-CI) parameter is always set to "0";
- the CPCS User-to-User Indication (CPCS-UU) parameter is always set to "0".

5.3.4.3 Procedures at the receiver side

Upon reception of a CPCS-UNITDATA.signal primitive, the variable Most_recent_CI_received is set to the value of the parameter CPCS - Congestion Indication (CPCS-CI) and the FR-SSCS-PDU is extracted from the parameter ID. The FR-SSCS-SDU, contained in the FR-SSCS-PDU information field is then passed:

- to the upper layer, in the case of a B-TE, using the DL-CORE DATA.indication primitive; or
- to the CCITT Recommendation Q.922 [22] core, in the case of a IWF, using the IWF-DATA.indication primitive.

The parameters of the primitives are defined in table 4.

Table 4: Values for the parameters of DL-CORE DATA.indication and IWF-DATA.indication primitives at the receiver side

Parameters:	DL-CORE DATA.indication primitive (B-TE)	IWF-DATA.indication primitive (IWF or FRSF)
DL-CORE user data	FR-SSCS-SDU (information field)	(as in B-TE)
DE	-(see note 1)	(see note 2)
CEB	is set to the value of the BECN field in the FR-SSCS-PDU	(as in B-TE)
CEF	is set to the logical OR of the values of the FECN field in the FR-SSCS-PDU and the parameter CPCS-CI of the CPCS-UNITDATA.signal primitive	(as in B-TE)
DL-CORE-Service-User protocol control information	is set to the value of the C/R field in the FR-SSCS-PDU	(as in B-TE)
DLCI or DL-CORE control indicator	see note 3	is set to the value of the D/C field in the FR-SSCS-PDU
DL-CORE control	see note 3	is set to the value of the DL-CORE control field in the FR-SSCS-PDU, if present
NOTE 1:	At the receiver side of the B-TE the information in the CPCS-LP parameter at the FR-SSCS may be conveyed to other entities, e.g. management.	
NOTE 2:	At the receiver side of the IWF or FRSF the Discard Eligibility (DE) parameter shall be set to either: case d) the value of the DE field in the FR-SSCS-PDU; or case e) the logical Or of the values of the DE field in the FR-SSCS-PDU and the parameter CPCS-LP of the CPCS-UNITDATA.signal primitive. Both cases d) and e) above shall be supported by the IWF or FRSF so that it can be negotiated at connection set-up or subscription on a CPCS connection by CPCS connection basis which one is used.	
NOTE 3:	Whether the DL-CORE control parameter and the DLCI or DL-CORE control indicator parameter are included in the DL-CORE DATA.indication primitive is for further study.	

5.3.4.4 Summary of parameters and values on the FR-SSCS connections

The information in table 5 needs to be known at CPCS-connection establishment and the value of the parameters for all FR-SSCS connections on a single CPCS-connection are the same.

Table 5: Parameters and values on a CPCS connection

Option parameter	Significance	Value/range	Reference
CPCS-LP parameter setting (see note 1)	Local sender	a) DE parameter b) "0" c) "1"	5.3.4.2
DE parameter setting (see note 1)	Local receiver	d) DE field (default, see note 2) e) DE field (logical OR) CPCS-LP parameter	5.3.4.3
NOTE 1:	The values applied for these two parameters are independent. However some combinations may not be meaningful depending on ATM connection characteristics.		
NOTE 2:	When the characteristics of the overall ATM-connection (expanded over more than 1 network) are not completely known, the default option shall be applied.		

Information on table 6 needs to be known at a FR-SSCS connection establishment.

Table 6: Parameters and values on a FR-SSCS connection

Option parameter	Significance	Value/range	Reference
Max CPCS-SDU length	peer-to-peer	[1 604 - (64k-1)] octets	[9]
Max FR-SSCS-SDU length (see note)	peer-to-peer	[1 600 - (64k-5)] octets	5.3.3.2
I.363:	ITU-T Recommendation I.363 [16].		
NOTE:	The value of this parameter shall always be lower than or equal to the value of the max CPCS-SDU length - 4.		

5.3.5 Frame Relay Permanent Virtual Connection (FR-PVC) monitoring

The following guidelines are identified in order to simplify the procedures necessary for the connection monitoring:

- management of the ATM layer and the FR-PVC monitoring of the FR-SSCS shall be regarded as being *decoupled*. Each layer has its own responsibility for the layer management (e.g. some functions of the management in the ATM layer will be performed by the usage of OAM cell flow);
- permanent virtual connection monitoring procedures discussed here only cover the FR-PVC carried by the ATM-network;
- management of the FR-SSCS shall be performed by symmetric PVC management procedures adopted from ITU-T Recommendation Q.933 [24]. The messages shall be significant for the VCC carrying the messages. This shall apply also for the B-ISDN TE. This also covers the case given in subclause 4.1.3;
- for FR-BAI in the cases given in subclauses 4.1.1 and 4.1.2, the management of the FR-SSCS may be, on a bilateral agreement basis, optionally performed by asymmetric PVC management procedures equivalent to procedures in ITU-T Recommendation Q.933 [24], annex A;
- for FR-PVC monitoring of frame relay connections carried by an ATM VCC, DLCI = 0 is used to identify and exchange FR-PVC monitoring messages between IWF(s) and/or B-ISDN TE(s) emulating frame relay (frame relay B-ISDN TE) and/or FRSF(s). All FR-PVC monitoring messages created by the FR-SSCS are transported transparently across the ATM network.

The symmetric management procedures are given in annex A.

5.4 Multiplexing of FRBS connections over B-ISDN

There are two schemes of multiplexing FRBS connections over B-ISDN:

- multiplexing at the FR-SSCS:
 - a number of frame relay logical connections are multiplexed into a single ATM virtual channel connection. Multiplexing is accomplished at the FR-SSCS using DLCIs. This is illustrated in figure 9;
- multiplexing at the ATM layer:
 - each frame relay logical connection is mapped to a single ATM virtual channel connection and multiplexing is accomplished at the ATM layer using Virtual Path Identifier/Virtual Channel Identifier (VPI/VCI). This is illustrated in figure 10.

In both multiplexing schemes, the FRBS connections are identified by the CCITT Recommendation Q.922 [22] core DLCI. The FR-SSCS links are identified by VPI/VCI and FR-SSCS DLCIs for the first multiplexing scheme. The FR-SSCS links are identified by VPI/VCI for the second multiplexing scheme (DLCI value at the FR-SSCS does not convey additional information).

All the above mentioned link identifiers have only local significance and their values have to be negotiated by subscription for both sides of the IWF.

In both multiplexing schemes, the DLCI value(s) used between two FR-SSCS entities (IWFs or FR-B-ISDN TEs) shall be agreed upon. The same FR-PVC monitoring procedures shall apply for both multiplexing schemes.

The first scheme of multiplexing (DLCI-based multiplexing) may only be used for FRBS VCs that terminate on the same ATM based end-systems (i.e. end-users or IWFs). FRBS VCs from a single source that terminate on different ATM-based end-systems shall be mapped to different ATM connections. In this case, the second scheme of multiplexing or a combination of the two schemes can be used.

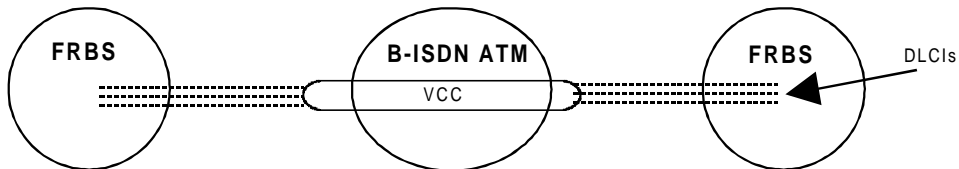

Figure 9: Multiple DLCIs multiplexed on a single ATM virtual channel connection

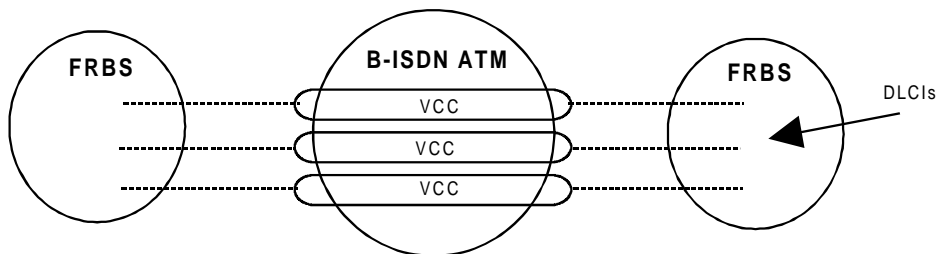

Figure 10: Each DLCI mapped into a separate ATM virtual channel connection

5.5 Congestion management strategy

The recommended congestion management strategy for the two multiplexing methods is as follows:

At the ingress point of the B-ISDN, in the first scheme the VCC may be composed of a large number of frame relay connections multiplexed to form a VCC. In the second scheme, a VPC may be composed of a large number of VCCs carrying frame relay traffic. If the number of frame relay connections or the number of VCCs is large, then according to the law of large numbers the resultant combined traffic over the ATM VCC or the VPC behaves almost as constant bit rate. As a consequence, statistical smoothing of the aggregate traffic at the ingress point to the B-ISDN will enable resource management on peak bandwidth allocation of the VCC or VPC, respectively, to achieve acceptable efficiency. The frame relay network congestion management option would then operate as usual. The FECN and BECN parameter values are not mapped to the AAL5 CPCS and ATM layer. However, congestion indication generated by the B-ISDN shall be taken into account when generating FECN/BECN towards the frame relay networks. This approach provides an averaged QoS over all ATM connections for frame relay carriage, and uses the preventative control of network resource management concept described in ETS 300 399-1 [5] annex C and ETS 300 301 [19].

Annex A (normative): Additional procedures for Frame Relay Permanent Virtual Connections (FR PVCs) for the carriage on ATM using unnumbered information frame

The management procedures (symmetric and asymmetric) for the FR-PVCs as described in ITU-T Recommendation Q.933 [24], annex A shall be applied with the following modifications:

- entities involved are terminals (as in ITU-T Recommendation Q.933 [24]), FRSFs, and IWFs (included under the term "network" in ITU-T Recommendation Q.933 [24]);
- the procedures are executed within the Layer Management Entity (LME) of the FR-SSCS;
- the use of the symmetric and asymmetric procedures is specified in subclause 5.3.5 of this ETS;
- procedures are applied per ATM connection instead of per bearer channel.

History

Document history			
March 1995	Public Enquiry	PE 81:	1995-03-27 to 1995-08-18
December 1997	Vote	V 9807:	1997-12-16 to 1998-02-13
March 1998	First Edition		