



**E**UROPEAN  
**T**ELECOMMUNICATION  
**S**TANDARD

**ETS 300 461-2**

October 1996

---

Source: ETSI TC-TM

Reference: DE/TM-01013-3

ICS: 33.040.20

**Key words:** transmission, MUX

**Transmission and Multiplexing (TM);  
Flexible Multiplexer (FM) equipment;  
Part 2: Management and control functions**

**ETSI**

European Telecommunications Standards Institute

**ETSI Secretariat**

**Postal address:** F-06921 Sophia Antipolis CEDEX - FRANCE

**Office address:** 650 Route des Lucioles - Sophia Antipolis - Valbonne - FRANCE

**X.400:** c=fr, a=atlas, p=etsi, s=secretariat - **Internet:** secretariat@etsi.fr

Tel.: +33 4 92 94 42 00 - Fax: +33 4 93 65 47 16

---

**Copyright Notification:** No part may be reproduced except as authorized by written permission. The copyright and the foregoing restriction extend to reproduction in all media.

© European Telecommunications Standards Institute 1996. All rights reserved.





|       |            |  |    |
|-------|------------|--|----|
|       | 7.2.5.1.1  | Option 1 - Evaluation without hysteresis .....                             | 31 |
|       | 7.2.5.1.2  | Option 2 - evaluation with hysteresis....                                  | 32 |
|       | 7.2.5.2    | 24 hour process .....  | 32 |
| 7.2.6 |            | Performance evaluation.....  | 33 |
| 7.2.7 |            | General performance functional diagram .....                               | 33 |
| 7.3   |            | Configuration management.....  | 36 |
|       | 7.3.1      | Configuration management overview .....                                    | 36 |
|       | 7.3.1.1    | Functional architecture.....   | 36 |
|       | 7.3.1.1.1  | Main functions .....   | 37 |
|       | 7.3.1.1.2  | CAS cross-connection functions .....                                       | 39 |
|       | 7.3.1.1.3  | Lower order section protection function.....                               | 41 |
|       | 7.3.1.1.4  | Lower order path protection functions..                                    | 42 |
|       | 7.3.1.1.5  | Tributary signal adaptation functions....                                  | 44 |
|       | 7.3.1.1.6  | Transfer of unstructured CCITT Recommendation G.703 [1]/ 2 048 kbit/s..... | 47 |
|       | 7.3.1.1.7  | Synchronization function .....   | 47 |
|       | 7.3.1.1.8  | Loops and tests functions .....  | 47 |
|       | 7.3.1.1.9  | Management functions.....  | 54 |
|       | 7.3.1.2    | Object classes.....  | 56 |
|       | 7.3.1.3    | Entities-relationships diagrams .....                                      | 57 |
| 7.3.2 |            | Description of the fragments.....  | 63 |
|       | 7.3.2.1    | Managed element fragment .....   | 64 |
|       | 7.3.2.2    | Aggregate fragment .....   | 64 |
|       | 7.3.2.2.1  | pPI1G703TTP (PI functional block) .....                                    | 64 |
|       | 7.3.2.2.2  | e1G704ATTP (PLPT functional block) .....                                   | 65 |
|       | 7.3.2.2.3  | e1CTP (connection termination point at 2 048 kbit/s).....                  | 67 |
|       | 7.3.2.2.4  | ts16ATTP (PLPT functional block).....                                      | 68 |
|       | 7.3.2.2.5  | e0CTP (Connection termination point at 64 kbit/s).....                     | 69 |
|       | 7.3.2.2.6  | casCTP (CAS Connection Point) .....  | 70 |
|       | 7.3.2.2.7  | saEocCTP (Sa bit EOC connection termination point) .....                   | 70 |
|       | 7.3.2.2.8  | e0G711ALTTP (TSA functional block) .....                                   | 71 |
|       | 7.3.2.2.9  | e0G722TTP (TSA functional block) .....                                     | 72 |
|       | 7.3.2.2.10 | e00VBCTP (Voice band connection termination point) .....                   | 73 |
|       | 7.3.2.2.11 | e00WBCTP (Wide band connection termination point) .....                    | 73 |
|       | 7.3.2.3    | Tributary fragment.....  | 74 |
|       | 7.3.2.3.1  | pPI0G703TTP (PI functional block) .....                                    | 74 |
|       | 7.3.2.3.2  | pPIx24TTP (PI functional block) .....                                      | 75 |
|       | 7.3.2.3.3  | pPIv24v10v11TTP (PI functional block).....                                 | 76 |
|       | 7.3.2.3.4  | pPI2W4WTTP (PI functional block) .....                                     | 77 |
|       | 7.3.2.3.5  | pPI2W4WDCTTP (PI functional block) .....                                   | 78 |
|       | 7.3.2.3.6  | pPI4WG722TTP (PI functional block)..                                       | 79 |
|       | 7.3.2.3.7  | G703aF (TPT/TST functional block) ....                                     | 80 |
|       | 7.3.2.3.8  | x24aF (TPT/TST functional block) .....                                     | 81 |
|       | 7.3.2.3.9  | v24aF (TPT/TST functional block) .....                                     | 83 |
|       | 7.3.2.3.10 | 2W4WaF (TPT/TST voice band functional block) .....                         | 85 |
|       | 7.3.2.3.11 | 2W4WDCaF (voice band and DC signalling functional block) .....             | 87 |
|       | 7.3.2.3.12 | 4WG722aF (wide band functional block).....                                 | 88 |
|       | 7.3.2.3.13 | e0tCTP (tributary CTP at 64 kbit/s) .....                                  | 90 |
|       | 7.3.2.3.14 | eNx0tCTP (tributary CTP at N x 64 kbit/s).....                             | 91 |
|       | 7.3.2.3.15 | e00VBCTP (voice band CTP) .....  | 92 |

|              |            |  |     |
|--------------|------------|--|-----|
|              | 7.3.2.3.16 | e00VBtCTP (voice band tributary CTP) .....           | 92  |
|              | 7.3.2.3.17 | e00WBCTP (wide band CTP).....                        | 93  |
|              | 7.3.2.3.18 | e00WBtCTP (wide band tributary CTP) .....            | 94  |
|              | 7.3.2.3.19 | sigTCTP (tributary signalling connection point)..... | 94  |
|              | 7.3.2.3.20 | sigCTP (signalling connection point) ....            | 95  |
|              | 7.3.2.3.21 | casTTP (TSA signalling functional block) .....       | 95  |
| 7.3.2.4      |            | Cross-connection fragment .....                      | 98  |
|              | 7.3.2.4.1  | fmFabric (XC functional block) .....                 | 98  |
|              | 7.3.2.4.2  | e0CrossConnection .....                              | 99  |
|              | 7.3.2.4.3  | casCrossConnection.....                              | 100 |
|              | 7.3.2.4.4  | e1CrossConnection .....                              | 101 |
|              | 7.3.2.4.5  | mngtCrossConnection .....                            | 101 |
|              | 7.3.2.4.6  | e0gtp (64 kbit/s group termination point) .....      | 102 |
|              | 7.3.2.4.7  | casgtp (64 kbit/s group termination point) .....     | 102 |
| 7.3.2.5      |            | Synchronization fragment .....                       | 103 |
|              | 7.3.2.5.1  | fmTimingGenerator (MTS functional block) .....       | 103 |
|              | 7.3.2.5.2  | pPI1G703ITSTTP (TIPI functional block) .....         | 104 |
|              | 7.3.2.5.3  | pPI1G703OTSTTP (TOPI functional block) .....         | 105 |
|              | 7.3.2.5.4  | tSProtectionGroup (MTS functional block) .....       | 106 |
|              | 7.3.2.5.5  | tSProtectionUnit (MTS functional block) .....        | 107 |
| 7.3.2.6      |            | Optional protection fragment .....                   | 108 |
|              | 7.3.2.6.1  | IPProtectionGroup (LPPSW functional block) .....     | 108 |
|              | 7.3.2.6.2  | IPProtectionUnit (LPPSW functional block) .....      | 109 |
|              | 7.3.2.6.3  | ISPProtectionGroup (LSPSW functional block).....     | 110 |
|              | 7.3.2.6.4  | ISProtectionUnit (LSPSW functional block) .....      | 111 |
|              | 7.3.2.6.5  | protectedTTP .....                                   | 111 |
|              | 7.3.2.6.6  | unprotectedCTP.....                                  | 112 |
| History..... |            |  | 113 |

Blank page

## Foreword

This European Telecommunication Standard (ETS) has been produced by the Transmission and Multiplexing (TM) Technical Committee of the European Telecommunications Standards Institute (ETSI).

This ETS is needed in order to provide the necessary information to network operators and equipment manufacturers for the deployment and design of Flexible Multiplexer equipment to be used in synchronous digital leased line networks. meet the requirements of

This ETS consists of two parts as follows:

Part 1: "Core functions, 2 048 kbit/s aggregate interface functions, tributary interface functions and special functions" (ETS 300 461-1);

**Part 2: "Management and control functions".**

| <b>Transposition dates</b>  |                 |
|---|-----------------|
| Date of adoption of this ETS:   | 4 October 1996  |
| Date of latest announcement of this ETS (doa):  | 31 January 1997 |
| Date of latest publication of new National Standard or endorsement of this ETS (dop/e): | 31 July 1997    |
| Date of withdrawal of any conflicting National Standard (dow):                          | 31 July 1997    |

Blank page



## 1 Scope

This European Telecommunication Standard (ETS) addresses management aspects of the Flexible Multiplexer (FM) equipment. The FM management functions are specified and management network architecture is described.

NOTE: The requirements of Flexible Multiplexer equipment with a variety of access methods for use in synchronous digital leased line networks are defined in part 1 of this ETS (ETS 300 461-1 [31]).

Sub-64 kbit/s signals are not precluded and are considered as an option that may be described according to the methodology used in this ETS. In the same way, special functions such as Adaptive Differential Pulse Code Modulation (ADPCM), conference bridges, etc., which are only mentioned in an annex of part 1 (ETS 300 461-1 [31]), are not considered.

The requirements presented here are limited to the basic functions, external characteristics and performance of the equipment. Some management functions may be implemented in a mediation device which may support both Q protocol adaptation and Operations Systems (OS) functionalities.

Part 1 of this ETS (ETS 300 461-1 [31]) defines functions and indicates whether or not they are mandatory. If supported, a function has to be managed according to this part 2 of this ETS. Part 2 of this ETS specifies when necessary the optional management characteristics (attributes, operations and notifications) of the objects.

## 2 Normative references

This ETS incorporates by dated and undated reference, provisions from other publications. These normative references are cited at the appropriate places in the text and the publications are listed hereafter. For dated references, subsequent amendments to or revisions of any of these publications apply to this ETS only when incorporated in it by amendment or revision. For undated references the latest edition of the publication referred to applies.

- [1] CCITT Recommendation G.703 (1991): "Physical/electrical characteristics of hierarchical digital interfaces".
- [2] CCITT Recommendation G.704 (1991): "Synchronous frame structures used at primary and secondary hierarchical levels".
- [3] CCITT Recommendation G.711 (1988): "Pulse code modulation (PCM) of voice frequencies".
- [4] CCITT Recommendation G.722 (1988): "7 kHz audio-coding within 64 kbit/s".
- [5] CCITT Recommendation G.762 (1990): "General characteristics of a 48-channel transcoder equipment".
- [6] ITU-T Recommendation G.774.03 (1992): "Synchronous digital hierarchy (SDH) management of multiplex-section protection for the network element view".
- [7] ITU-T Recommendation G.784 (1994): "Synchronous digital hierarchy (SDH) management".
- [8] ITU-T Recommendation G.805 (1995): "Generic functional architecture of transport networks".
- [9] ITU-T Recommendation G.826 (1993): "Error performance parameters and objectives for international, constant bit rate digital paths at or above the primary rate".
- [10] ITU-T Recommendation M.20 (1992): "Maintenance philosophy for telecommunications networks".

- [11] ITU-T Recommendation M.2100 (1992): "Performance limits for bringing-into-service and maintenance of digital paths, sections and transmission systems".
- [12] ITU-T Recommendation M.2110 (1993): "Bringing into service international digital paths, sections and transmission systems".
- [13] ITU-T Recommendation M.2120 (1993): "Digital path, section and transmission system fault detection and localization procedures".
- [14] ITU-T Recommendation M.3010 (1992): "Principles for a telecommunications management network".
- [15] CCITT Recommendation M.3100 (1992): "Generic network information model".
- [16] ITU-T Recommendation O.151 (1993); "Error performance measuring equipment operating at the primary rate and above".
- [17] ITU-T Recommendation V.24 (1993): "List of definitions for interchange circuits between data terminal equipment (DTE) and data circuit terminating equipment (DCE)".
- [18] CCITT Recommendation V.25bis (1989): "Automatic calling and/or answering equipment on the general switched telephone network (GSTN) using the 100-series interchange circuits".
- [19] CCITT Recommendation V.54 (1988): "Loop test devices for modems".
- [20] CCITT Recommendation X.24 (1988): "List of definitions for interchange circuits between data terminal equipment (DTE) and data circuit-terminating equipment (DTE) on public data networks".
- [21] CCITT Recommendation X.150 (1988): "Principles of maintenance testing for public data networks using data terminal equipment (DTE) and data circuit-terminating equipment (DCE) test loops".
- [22] CCITT Recommendation X.710 (1991): "Common management information service definition for CCITT applications".
- [23] ITU-T Recommendation X.721 (1992): "Information technology - Open Systems Interconnection - Structure of management information: Definition of management information".
- [24] ITU-T Recommendation X.731 (1992): "Information technology - Open Systems Interconnection - System management: State management function".
- [25] ITU-T Recommendation X.733 (1992): "Information technology - Open Systems Interconnection - System management: Alarm reporting function".
- [26] ETR 135 (1993): "Transmission and Multiplexing (TM); Network aspects and applications for a 4 (and n x 4) kbit/s data link in 2 048 kbit/s frame".
- [27] ETS 300 150 (1992): "Transmission and Multiplexing (TM); Protocol suites for Q interfaces for management of transmission systems".
- [28] ETS 300 304 (1994): "Transmission and Multiplexing (TM); Synchronous Digital Hierarchy (SDH) information model for the Network Element (NE) view".
- [29] ETS 300 371 (1994): "Transmission and Multiplexing (TM); Plesiochronous Digital Hierarchy (PDH) information model for the Network Element (NE) view".

- [30] ETS 300 376-1 (1994): "Signalling Protocols and Switching (SPS); "Q3 interface at the Access Network (AN) for configuration management of V5 interfaces and associated user ports Part 1: Q3 interface specification".
- [31] ETS 300 461-1 (1996): "Transmission and Multiplexing (TM); Flexible Multiplexer (FM) equipment; Part 1: Core functions, 2 048 kbit/s aggregate interface functions, tributary interface functions and special functions".
- [32] ETR 241: "Transmission and Multiplexing (TM); Functional architecture of 2 Mbit/s based Plesiochronous Digital Hierarchy (PDH) transport networks".

### 3 Definitions and abbreviations

#### 3.1 Definitions

For the purposes of this ETS, the following definitions apply:

**Physical Interface (PI):** This function terminates and generates the signals of either a tributary or an aggregate circuit. The PI functional block recovers the timing signal (X or T2 reference point) from the received signal. The function detects loss of signal condition. When appropriate, the line code violations are also detected.

**lower order section protection switch:** This optional function is used when 1+1 protection switching is required for the 2 048 kbit/s digital section.

**plesiochronous lower order path termination:** This function terminates and generates a logical signal at 2 048 kbit/s at an aggregate interface. The function provides frame generation and recovery and detection of defect and failure conditions on the 2 048 kbit/s logical signal.

**lower order path protection switch:** This optional function is used when either 1+1 or 1 for n protection switching is required for the 2 048 kbit/s digital path.

**remote multiframe alarm indication:** This alarm corresponds to the Remote Alarm Indication (RAI) in time slot 16, as defined in part 1 of this ETS (ETS 300 461-1 [31]).

**cross connection function:** This function allows the cross connection of 64 and n x 64 kbit/s signals between the same or different reference points.

**channel associated signalling cross connection function:** If channel associated signalling or control is used then this function allows the cross connection of the associated signalling signals at 4 x 500 bit/s or n x 4 x 500 bit/s between the same or different reference points.

**Special Function (SF):** Examples of optional special functions are analogue multipoint conference bridge, data multipoint bridge and broadcasting.

**Tributary Signal Adaptation (TSA):** This function modifies the tributary signal, when necessary, into a 64 kbit/s channel suitable for the cross connection function. It also carries out the reverse function.

**Tributary Path Termination (TPT)/Tributary Signal Termination (TST):** This function generates or terminates tributary information and any related signalling or control signals.

**administrative state:** The meaning of the administrative state is described in each object definition, when applicable.

**null:** This attribute value indicates that the function exists and is not activated.

### 3.2 Symbols

For the purposes of this ETS, the following symbols apply:

|                           |  |
|---------------------------|--|
| <b>2W4WaF</b>             | 2 Wires 4 Wires adaptation Function                                  |
| <b>4WG722aF</b>           | 4 Wires G722 adaptation Function                                     |
| <b>casCrossConnection</b> | channel associated signalling Cross-Connection                       |
| <b>casCTP</b>             | channel associated signalling Connection Termination Point           |
| <b>castCTP</b>            | channel associated signalling tributary Connection Termination Point |
| <b>casTTP</b>             | channel associated signalling Trail Termination Point                |
| <b>casgtp</b>             | channel associated signalling group termination points               |
| <b>e00VBCTP</b>           | subrate voice Band Connection Termination Point                      |
| <b>e00VBtCTP</b>          | subrate voice Band tributary Connection Termination Point            |
| <b>e00WBCTP</b>           | subrate Wide Band Connection Termination Point                       |
| <b>e00WBtCTP</b>          | subrate Wide Band tributary Connection Termination Point             |
| <b>e0CrossConnection</b>  | 64 kbit/s Cross-Connection   |
| <b>e0CTP</b>              | 64 kbit/s Connection Termination Point                               |
| <b>e0G711ALTTP</b>        | 64 kbit/s G711 A Law Trail Termination Point                         |
| <b>e0G722TTP</b>          | 64 kbit/s G722 Trail Termination Point                               |
| <b>e0gtp</b>              | 64 kbit/s Group Termination Points                                   |
| <b>e0tCTP</b>             | 64 kbit/s tributary Connection Termination Point                     |
| <b>e1CrossConnection</b>  | 2 Mbit/s Cross-Connection  |
| <b>e1CTP</b>              | 2 Mbit/s Connection Termination Point                                |
| <b>e1G704ATTP</b>         | 2 Mbit/s G704 AIS Trail Termination Point                            |
| <b>eNx0CTP</b>            | N x 64 kbit/s Connection Termination Point                           |
| <b>fmEquipement</b>       | replaceable units of the flexible multiplexer                        |
| <b>fmFabric</b>           | Fabric of the flexible multiplexer                                   |
| <b>fmPowerFeeding</b>     | Power Feeding of the flexible multiplexer                            |
| <b>fmSoftware</b>         | Software of the flexible multiplexer                                 |
| <b>fmTimingGenerator</b>  | Timing Generator of the flexible multiplexer                         |
| <b>imTP</b>               | internal management Termination Point                                |
| <b>lcCTP</b>              | local management Connection Termination Point                        |
| <b>IPProtectionGroup</b>  | low order path Protection Group                                      |

|                            |   |
|----------------------------|---|
| <b>IPProtectionUnit</b>    | low order path Protection Unit  |
| <b>ISProtectionGroup</b>   | low order section Protection Group  |
| <b>ISProtectionUnit</b>    | low order section Protection Unit   |
| <b>mCTP</b>                | reference point M Connection Termination Point                                      |
| <b>mngtCrossConnection</b> | management Cross-Connection   |
| <b>pPI0G703TTP</b>         | plesiochronous Physical Interface 64 kbit/s G703 Trail Termination Point            |
| <b>pPI1G703ITSTTP</b>      | plesiochronous Physical Interface G703 Input Timing Source Trail Termination Point  |
| <b>pPI1G703OTSTTP</b>      | plesiochronous Physical Interface G703 Output Timing Source Trail Termination Point |
| <b>pPI1G703TTP</b>         | plesiochronous Physical Interface G703 Trail Termination Point                      |
| <b>pPI2W4WTTP</b>          | plesiochronous Physical Interface 2 Wires/4 Wires Trail Termination Point           |
| <b>pPI4WG722TTP</b>        | plesiochronous Physical Interface 4 Wires G722 Trail Termination Point              |
| <b>pPIv24v10v11TTP</b>     | plesiochronous Physical Interface v24/v10/v11 Trail Termination Point               |
| <b>pPIx24TTP</b>           | plesiochronous Physical Interface X24 Trail Termination Point                       |
| <b>protectedTTP</b>        | protected Trail Termination Point   |
| <b>q3CTP</b>               | Q3 Connection Termination Point   |
| <b>saEocCTP</b>            | sa bit Embedded operating channel Connection Termination Point                      |
| <b>saEoctCTP</b>           | sa bit Embedded operating Channel Tributary Connection                              |
| <b>sigCTP</b>              | signalling Connection Termination Point   |
| <b>sigtCTP</b>             | signalling tributary Connection Termination Point                                   |
| <b>ts16ATTP</b>            | time slot 16 AIS Trail Termination Point  |
| <b>tSPProtectionGroup</b>  | timing Source Protection Group  |
| <b>tSPProtectionUnit</b>   | timing Source Protection Unit   |
| <b>unprotectedCTP</b>      | unprotected Connection Termination Point  |
| <b>v24aF</b>               | V24 adaptation Function   |
| <b>x24aF</b>               | X24 adaptation Function   |

### 3.3 Abbreviations

For the purposes of this ETS, the following abbreviations apply:

|       |   |
|-------|---|
| ADPCM | Adaptive Differential Pulse Code Modulation |
| AIS   | Alarm Indication Signal                     |
| BVE   | Bipolar Violation Error                     |
| CAS   | Channel Associated Signalling               |
| CMIS  | Common Management Information Service       |

|       |  |
|-------|--|
| CPU   | Control Processing Unit  |
| CRC   | Cyclic Redundancy Check  |
| DCE   | Data Circuit-terminating Equipment   |
| DFC   | Default and Failure Condition  |
| DTE   | Data Terminal Equipment  |
| DXC   | Digital cross Connect  |
| EOC   | Embedded Operation Channel   |
| EMF   | Equipment Management Function  |
| EXBER | EXcessive Block Error Ratio  |
| F     | a management interface connecting workstation to the OSF or the MF according to ITU-T Recommendation M.3010 [14]                   |
| FM    | Flexible Multiplexer   |
| LCI   | a non-standard Local Control Interface   |
| LMFA  | Loss of MultiFrame Alignment   |
| LPPSW | Lower order Path Protection Switch   |
| LSPSW | Lower order Section Protection Switch  |
| LOF   | Loss Of Frame  |
| LOS   | Loss Of Signal   |
| LSR   | Loss of Synchronization Reference  |
| m     | a non-standard reference point between equipment function and the Q Adapter function according to CCITT Recommendation M.3010 [14] |
| MCF   | Message Communication Function   |
| MD    | Mediation Device   |
| MF    | Mediation Function   |
| MTS   | Multiplexer Timing Source  |
| NE    | Network Element  |
| NTU   | Network Terminating Unit   |
| NFAS  | Non-Frame Alignment Signal   |
| OAN   | Optical Access Network   |
| ONP   | Open Network Provision   |
| OS    | Operations Systems   |
| OSF   | Operations Systems Function  |
| PCM   | Pulse Code Modulation  |
| PDH   | Plesiochronous Digital Hierarchy   |
| PI    | Physical Interface   |
| PLPT  | Plesiochronous Lower order Path Termination  |
| PRBS  | Pseudo Random Bit Sequence   |
| QAF   | Q Adapter Function   |
| RAI   | Remote Alarm Indication  |
| RMAI  | Remote Multiframe Alarm Indication   |
| ROT   | Remove Octet Timing  |
| RP    | Reference Point  |
| SF    | Special Function   |
| SFI   | Synchronization Failure Indication   |
| SDH   | Synchronous Digital Hierarchy  |
| SIGCE | Signalling Condition Error   |
| STM-1 | Synchronous Transport Module level 1   |
| TMN   | Telecommunication Management Network   |
| TPT   | Tributary Path Termination   |
| TS    | Time Slot from a 2 048 kbit/s G.704 frame  |
| TSA   | Tributary Signal Adaptation  |
| TSn   | Time Slot number n (from 0 to 31)  |
| TST   | Tributary Signal Termination   |
| TTP   | Trail Termination Point  |
| UT    | Unavailable Time   |
| VF    | Voice Frequency  |
| WS    | Work Station   |
| XC    | Cross-Connection   |

## 4 Management network

### 4.1 Principle

Characterization of the management network is derived from ITU-T Recommendation G.784 [7], especially figure 1 of ITU-T Recommendation G.784 [7]. Figure 1 of this ETS reproduces similar organization for the management view of management network where Embedded Operation Channel (EOC) replaces the specific Synchronous Digital Hierarchy (SDH) error check and correction. This figure relates only to functional aspects and does not presume implementation or routing facilities. EOC could be either supported by a particular 64 kbit/s Time Slot (TS) from a 2 048 kbit/s CCITT Recommendation G.704 [2] frame or by one or some of the Sa bits of CCITT Recommendation G.704 [2] frame.

Network Elements (NE) could be directly connected with a Mediation Device (MD) or via other devices, including NEs.

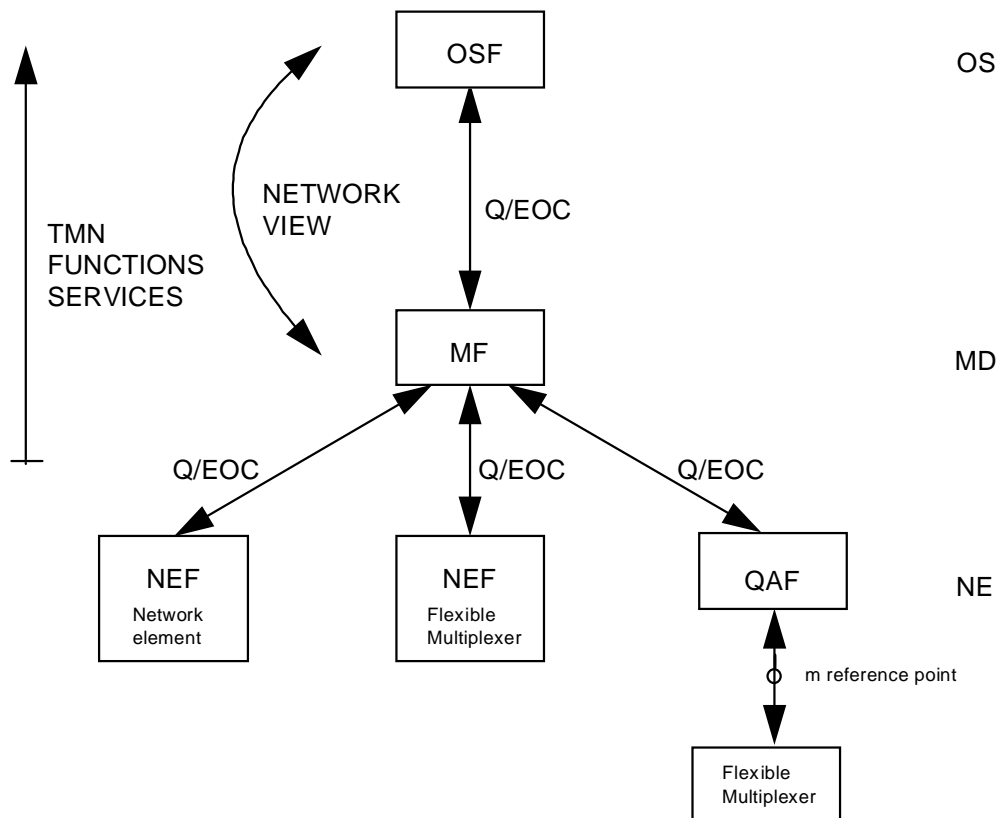

NOTE 1: Network operators may require to provide duplication of the management interface.

NOTE 2: The Q Adapter Function (QAF) function may also be included in the Flexible Multiplexer, giving it the status of a NE.

**Figure 1: Functional view of management network**

### 4.2 Application to the Flexible Multiplexer

Figure 2 describes various means that may be provided to access the control and management functions of a FM as defined in ETS 300 461-1 [31].

U1 and U3 are reference points for 4 (or  $n \times 4$ ) kbit/s EOC as described in ETR 135 [26]. The EOC (reference point U3) may be activated to allow an authorized customer to perform a set of management functions. The EOC (reference point U1) may be activated to provide an embedded transport function for management information acting logically as an m reference point. It is assumed that the EOC is typically to be related to interfaces supporting CCITT Recommendation G.704 [2] framing and the use of corresponding Sa bit(s). Nevertheless, it is not precluded that for tributary interfaces based on

ITU-T Recommendation V.24 [17], the EOC may be replaced by an asynchronous or synchronous command set as defined in draft CCITT Recommendation V.25bis [18].

U2 is the reference point for 64 kbit/s EOC. As shown in figure 1, this EOC may provide an embedded transport function for management information acting logically as a q or m reference point. It may also relay signals from/to the F interface allowing communication between a workstation at the f reference point and the Operations System. It is assumed that the 64 kbit/s EOC, when activated is supported by a 64 kbit/s circuit from one of the 2 048 kbit/s aggregate signals.

F represents a management interface connecting a workstation to the OSF or the MF according to ITU-T Recommendation M.3010 [14] (see also clause 6).

m represents a non-standard reference point between Equipment Function and the Q Adapter Function according to ITU-T Recommendation M.3010 [14] (see also clause 6).

LC represents a user interface for local operation (not to be standardized, see also clause 6).

NOTE: It is not always necessary to have all management interfaces and provision of all alternatives for the EOC. When provided, activation or deactivation of any of the EOC or management interface, selection of associated bit rate, selection of Sa bit(s) or 64 kbit/s circuit, characterization of the set of commands available from reference point U3, setting any protection function for management interfaces or EOC are part of management functions. It should be possible to set the default means of operation by the use of LC interface.

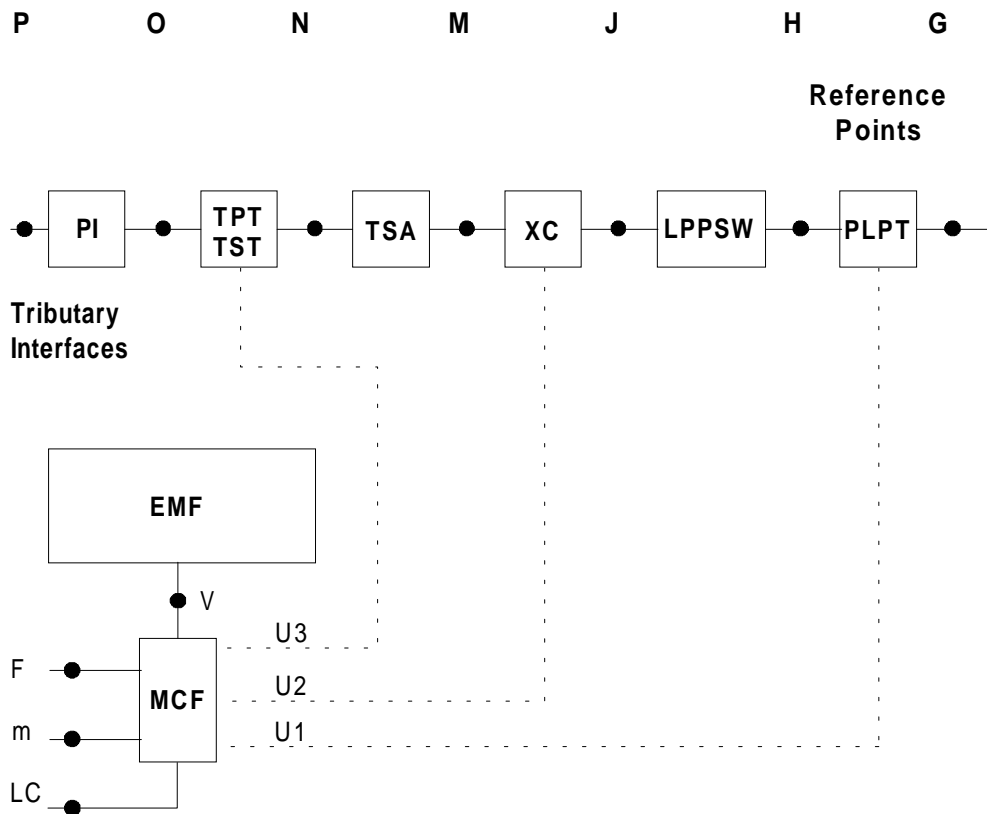

Figure 2: Access to management functions for a FM

Reference should be made to ETR 135 [26] for the structure of EOC at reference points U1 and U3 (alternatively at reference point U2). Reference should be made to ETS 300 150 [27] for the structure of an EOC supporting a q reference point at reference point U2. In both cases application layers are not subject to standardization.

The following figure 3 is only given as an example of management network organization for a FM and does not preclude alternative structures.



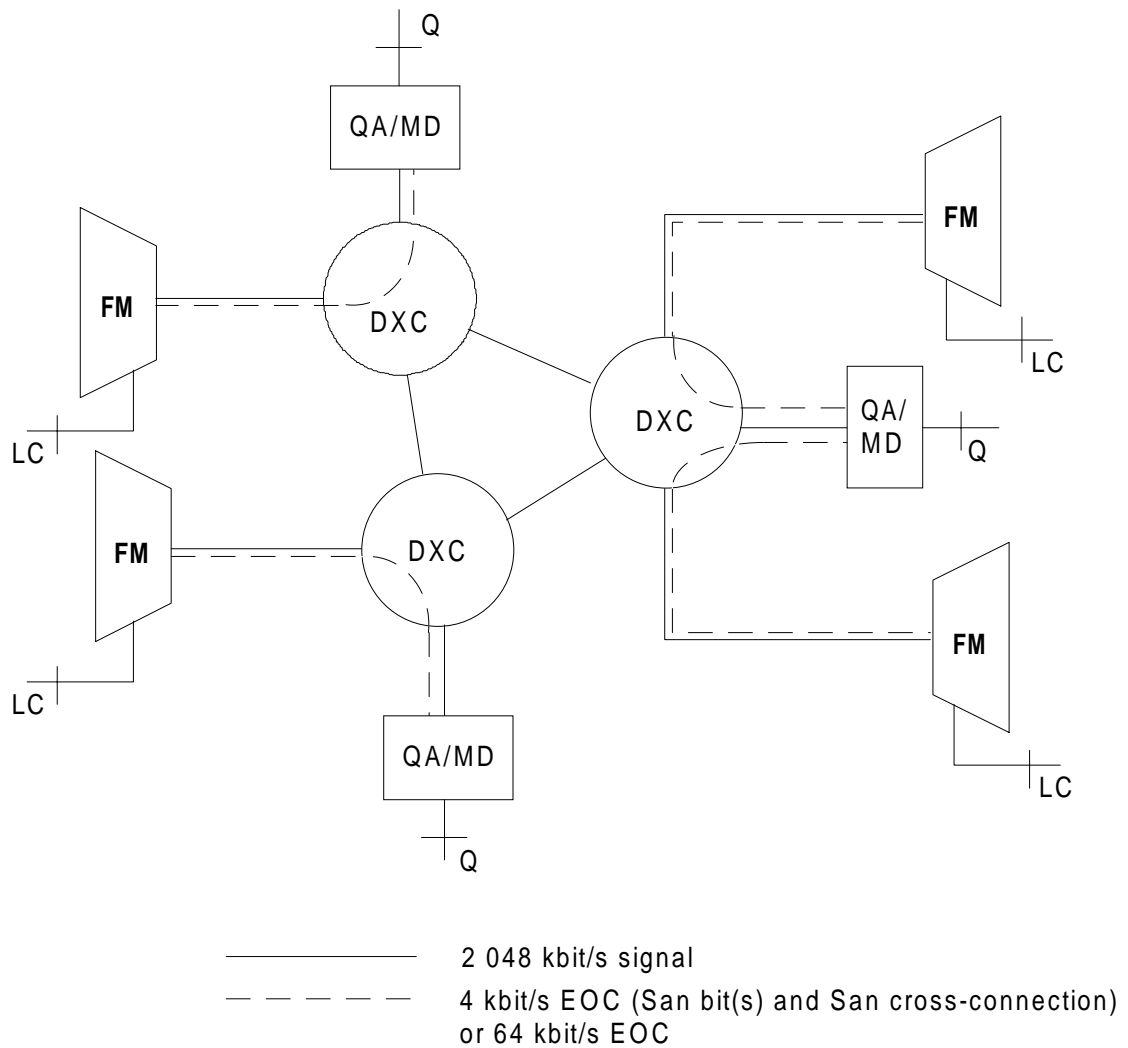

Figure 3: A possible configuration for a FM management network

## 5 Information model

There is no information model in this edition of the ETS.

## 6 Management interfaces

The FM shall be able to terminate and generate the management control channel(s). For this purpose, it should present the following interfaces according to ITU-T Recommendation M.3010 [14]:

- **Q-interface:** this interface provides a management control channel between the Operations Systems (OS) and the FM. Depending on the management network implementation, it could be a Qx or a Q3 interface.  
 The Q interface is optional in the FM equipment: If this Q interface is not provided, an interface supporting the m-reference point shall be provided (see below);
- **F-interface:** this optional interface provides Work Station (WS) access to the OS via the FM;
- **m-reference point:** this is supported by a proprietary interface and allows a management connection via an external Q Adapter Function (QAF), between an OS conforming to Telecommunication Management Network (TMN) recommendations and a FM that does not conform to TMN recommendations;

- **Local interface:** additionally, the FM shall provide a Local Control (LC) interface for local attachment of a proprietary management entity. The purpose of this interface is to facilitate:
  - installation and maintenance (with changes of the FM configuration), in cases where the connection to the OS is interrupted or voluntarily blocked;
  - local monitoring of the FM status (without changes of the FM configuration).

NOTE: For the first case, means should be implemented in the FM and/or the OS to overcome conflict/misalignment situations between the FM configuration locally induced via the LC interface and the FM configuration as it is stored in the OS database.

## **7 Applications functions**

### **7.1 Fault management**

#### **7.1.1 Alarm surveillance**

##### **7.1.1.1 Principle**

Alarm surveillance is concerned with the detection and reporting of relevant events/conditions which occur in the equipment or which is detected at the level of the equipment. Events/conditions detected within the equipment and in the incoming signals shall be reportable. Alarms are indications that are automatically generated by the equipment or NE as the result of certain events/conditions and associated processing. The user shall have the ability to define which events/conditions generate autonomous reports. The remaining events/conditions stored in a log are reportable on request.

The relevant events/conditions are derived from the DFC (Defect and Failure Conditions) given in ETS 300 461-1 [31]. The processing associated to the occurrence of a DFC is described in figure 4 below.

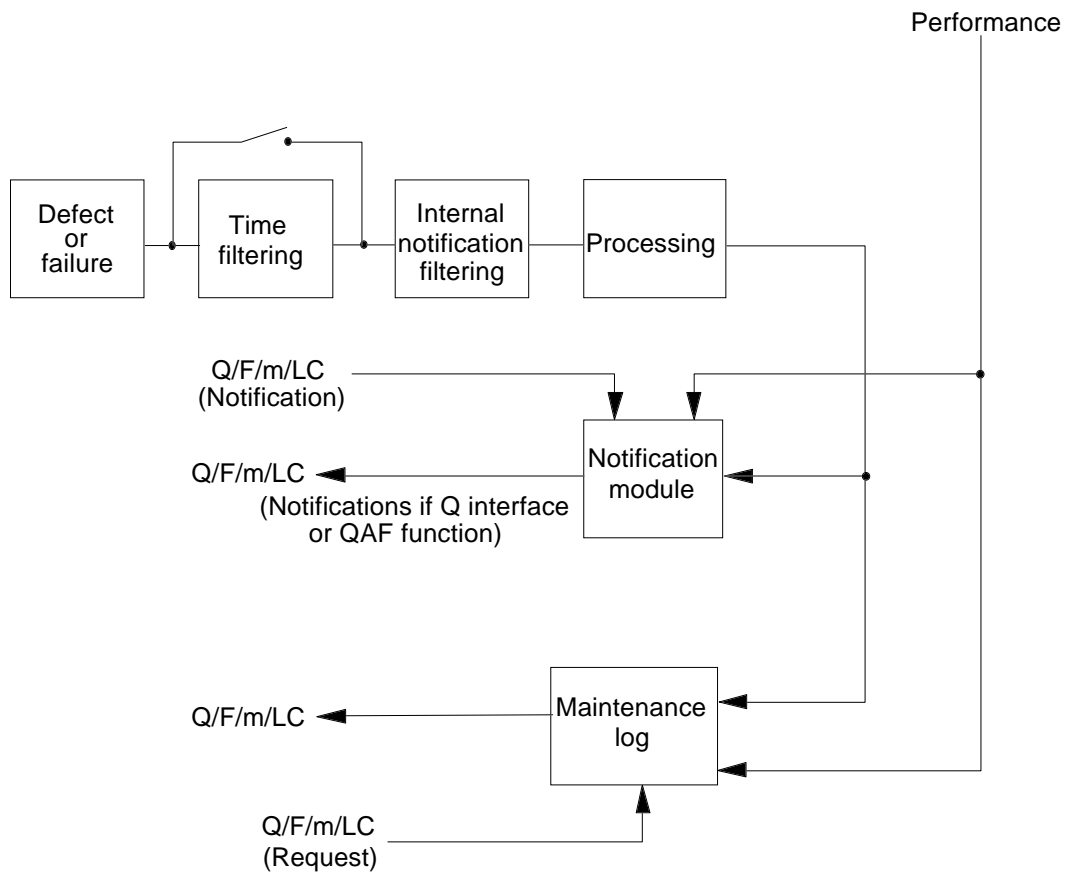

NOTE 1: TMN requires notification function: this may be supported either by the equipment itself or by a QAF function.

NOTE 2: The "configure" arrows is shown according to the text of subclause 7.1.1.1. This representation does not preclude that time filtering module, internal notification module and processing module are also configurable.

**Figure 4: Alarm related maintenance functions**

Functions associated to the various functional blocks to figure 4 should be according to following:

- **defect or failure:** This functional block performs the elementary functions necessary to the detection of any of the defect or failure conditions determined in ETS 300 461-1 [31] or specified in this part of the ETS;
- **time filtering:** This functional block provides optional programmable time filtering, ranging from 0 to 10 s by step of 1 s, which allows the consideration of a selected defect or failure condition only if its duration is greater than a predetermined value;
- **internal notification filtering:** This functional block manages the transmission of notifications (occurring, disappearing of DFC) to the appropriate functional block. It also permits the allowance/inhibition or the discrimination of a given DFC depending upon its nature and, if necessary, to address it to appropriate functional blocks;
- **processing:** This function receives the various notifications, gathers them and performs the necessary correlation in such a way that not any redundant information will be notified. In addition, this function may allow to provide a diagnostic for the occurrence of a DFC. The functional processing block generates the synthetic notifications addressed to the Equipment Management Function (EMF);
- **notification module:** This functional block is under the control of the user who determines the notifications required to be spontaneously transmitted to Q/F/m interface(s). The module includes an events discriminator and also programmable notification filtering in the range of 0 to 60 s by step

of 10 s. If the equipment supports a notification protocol, it may spontaneously transmit notifications. If not, the equipment shall keep a record of current events (or alarms);

- **maintenance log:** This functional block registers in a given memory size a list of all DFCs occurring in the FM. A stored DFC should include: probable cause (i.e. LOS, LFA, etc.), type, managed function, time (occurrence, clearing). The user shall have the ability to request transmission or display of stored information according to criteria described in subclause 7.1.1.2.

NOTE 3: Diagnostic functions may help to locate and to identify the probable cause of alarms.

#### 7.1.1.2 Alarm-related functions

The following alarm-related functions are mandatory and shall be supported at equipment level:

- report autonomous alarms;
- request current alarm summary (alarm status);
- request alarm report history;
- report all alarms;
- allow/inhibit alarm reporting on each management interface.

The following alarm-related functions are optional and may be required to be supported at equipment level:

- route alarm report;
- delete alarm report;
- report current alarm summary;
- supplementary current alarm summary functions (allow/inhibit, schedule, route, request schedule, request route);
- condition/request alarm event criteria;
- inhibit/allow audible/visual local alarm;
- inhibit/allow logging (basic log control);
- condition logging (enhanced control).

#### 7.1.1.3 Logs and memory

The equipment shall provide an alarm record which represents information stored in a log(s). The record conforms to the specification defined in ITU-T Recommendation X.721 [23] and contains the following attributes:

- record identifier;
- logging time (time the record was created);
- event time (time the event was generated) if the event time parameter was present in the CMIP event report;
- identification of the source of the alarm event (managed object class and instance);
- the event type (see subclause 7.1.2.1);
- probable cause;

- perceived severity.

As an option, the following attribute may be present:

- backed-up status.

### 7.1.2 Alarm classification

Alarms should be classified using the alarm type categories and perceived severity defined in ITU-T Recommendation X.733 [25]. The probable cause of an alarm is derived from the defect or failure condition defined in ETS 300 461-1 [31], clause 10.

#### 7.1.2.1 Alarm type

Five basic categories of alarms are specified. These are given in subclauses 7.1.2.1.1 to 7.1.2.1.5.

Table 1 in subclause 7.1.2.1.6 lists the different alarms and the default severity. The severity of an alarm is given in subclause 7.1.2.2.

##### 7.1.2.1.1 Communications alarm type probable cause

This type of alarm includes the following defect or failure conditions which are given with the associated functional part of the FM equipment (ETS 300 461-1 [31], clause 10):

- 2 048 kbit/s unstructured aggregate interface;
  - loss of incoming signal (see ETS 300 461-1 [31], subclause 10.2.1.1);
  - bipolar violation error (see ETS 300 461-1 [31], subclause 10.2.1.2).
- 2 048 kbit/s CCITT Recommendation G.703 [1] aggregate interface;
  - loss of incoming signal (see ETS 300 461-1 [31], subclause 10.2.1.1);
  - bipolar violation error (see ETS 300 461-1 [31], subclause 10.2.1.2);
  - loss of frame alignment (see ETS 300 461-1 [31], subclause 10.3.1.1);
  - excessive error ratio (see ETS 300 461-1 [31], subclause 10.3.1.2);
  - defect indication from a remote equipment (see ETS 300 461-1 [31], subclause 10.3.1.3):
    - remote alarm indication (bit 3 of TS0 NFAS);
    - remote AIS defect indication;
    - remote synchronization failure indication.
  - AIS received (see ETS 300 461-1 [31], subclause 10.3.1.4);
  - loss of MultiFrame alignment (see ETS 300 461-1 [31], subclause 10.3.1.5);
  - remote multiframe alarm indication (see ETS 300 461-1 [31], subclause 10.3.1.6);
  - AIS received in TS16 (see ETS 300 461-1 [31], subclause 10.3.1.7);
  - frame slip (see ETS 300 461-1 [31], subclause 10.3.1.8);
  - CRC4 block error (see ETS 300 461-1 [31], subclause 10.3.1.9);
  - remote CRC4 block error (see ETS 300 461-1 [31], subclause 10.3.1.10).
- 2W/4W voice band (3 400 Hz) interface;
  - none (see ETS 300 461-1 [31], subclause 10.4.1.1).
- 2W/4W voice band (3 400 Hz) with DC signalling interface;
  - none (see ETS 300 461-1 [31], subclause 10.4.1.2).
- PSTN interface;
  - not specified (see ETS 300 461-1 [31], subclause 10.4.1.3).
- wide band interface (7 kHz);

- none (see ETS 300 461-1 [31], subclause 10.4.1.4).
- CCITT Recommendation G.703 [1] /64 kbit/s codirectional interface;
  - loss of signal (see ETS 300 461-1 [31], subclause 10.4.1.5 item a);
  - loss of octet timing (see ETS 300 461-1 [31], subclause 10.4.1.5 item b).
- CCITT Recommendation X.24 [20] interface;
  - electrical failure of circuit T and C (see ETS 300 461-1 [31], subclause 10.4.1.6 item a);
  - loss of connection between DTE and DCE (see ETS 300 461-1 [31], subclause 10.4.1.6 item b);
  - loss of power at the DTE (see ETS 300 461-1 [31], subclause 10.4.1.6 item c).
- ITU-T Recommendation V.24 [17] (V.10 and V.11) interface;
  - loss of connection between DTE and DCE (see ETS 300 461-1 [31], subclause 10.4.1.7 item a);
  - loss of power at the DTE (see ETS 300 461-1 [31], subclause 10.4.1.7 item b).
- integrated baseband interface;
  - not specified (see ETS 300 461-1 [31], subclause 10.4.1.8).
- CCITT Recommendation G.704 [2] formatted n x 64 kbit/s signal interface;
  - loss of signal (see ETS 300 461-1 [31], subclause 10.4.1.9 item a);
  - loss of frame alignment (see ETS 300 461-1 [31], subclause 10.4.1.9 item b);
  - excessive error ratio (see ETS 300 461-1 [31], subclause 10.4.1.9 item c);
  - defect indication from a remote equipment (see ETS 300 461-1 [31], subclause 10.4.1.9 item d);
  - AIS received (see ETS 300 461-1 [31], subclause 10.4.1.9 item e);
  - frame slip (see ETS 300 461-1 [31], subclause 10.4.1.9 item f);
  - CRC4 block error (see ETS 300 461-1 [31], subclause 10.4.1.9 item g);
  - remote CRC4 block error (see ETS 300 461-1 [31], subclause 10.4.1.9 item h).
- when TS 16 is used and declared for channel associated signalling;
  - loss of MultiFrame alignment (see ETS 300 461-1 [31], subclause 10.4.1.9);
  - remote multiframe alarm indication (see ETS 300 461-1 [31], subclause 10.4.1.9);
  - AIS received in TS16 (see ETS 300 461-1 [31], subclause 10.4.1.9).
- ISDN interface;
  - not specified (see ETS 300 461-1 [31], subclause 10.4.1.10).
- CCITT Recommendation G.703 [1]/2 048 kbit/s unstructured interface;
  - loss of incoming signal (see ETS 300 461-1 [31], subclause 10.4.1.11 item a);
  - bipolar violation error (see ETS 300 461-1 [31], subclause 10.4.1.11 item b).
- management links;
  - alarm indicating failure in management link(s), if appropriate.
- external synchronization link;
  - alarm indicating that the equipment is no more synchronized by an external source.

The notification of each alarm shall be in accordance with the filtering values defined in subclause 7.1.1.1.

#### 7.1.2.1.2 Equipment alarms type (core alarm type)

This type of alarm includes at least the following defect or failure conditions:

- power supply failure (see ETS 300 461-1 [31], subclause 10.1.1.1):  
  
this alarm shall be activated either by the absence of external power supply or a fault in the FM dedicated power supply unit.
- synchronization interface(s):  
  
loss of synchronization references (see ETS 300 461-1 [31], subclause 10.1.1.2).
- failure of an interface:  
  
depending on the requirements of each interface, the different physical functions (Physical Interface (PI) + Lower order Section Protection Switch (LSPSW) + Plesiochronous Lower order Path Termination (PLPT) + Lower order Path Protection Switch (LPPSW) + functions or PI + Tributary Path Termination (TPT)/Tributary Signal Termination (TST) + Tributary Signal Adaptation (TSA) functions) shall be provided with an appropriate check procedure to detect the following defect/failure conditions:
  - TX/RX circuits, included the elastic stores if used;
  - loss of internal timing signals from MTS function;
  - loss of internal power feeding;
  - internal communication interface with common logic;
  - internal interface with cross-connection function.
- failure of a connection or of a special function:  
  
the Cross-connection Function (XC), the Channel Associated Signalling (CAS) cross-connection function (CAS XC), and the Special Functions (SF) should be provided with appropriate check procedures to detect defect/failure conditions on a 64 or n x 64 Kbit/s connection and on the special function. The FM control system should be able to indicate the part or unit of the equipment that causes the failure.
- timing failure:  
  
the MTS function should be provided with an appropriate check procedure to detect the loss of T1 signal (and/or T4 signal if required).
- common logic failure:  
  
the FM should be provided with appropriate check procedure to detect at least:
  - defect/failure of the CPUs;
  - defect of the program memory;
  - defect of the data memory;
  - loss of the internal power feeding.

#### 7.1.2.1.3 Processing alarm type

Alarms of this type may include the following probable cause:

- time management;
- alarm memory (overflow);
- down loading software error;
- software corruption;
- misalignment of the data-base;
- version mismatch.

Depending on the implementation, other probable causes may be added (see ITU-T Recommendation X.733 [25]).

#### **7.1.2.1.4 Environmental alarm type**

The equipment may detect external alarms, depending on individual requirements of the operator, such as:

- fire;
- door opening;
- dry loops.

Depending of the implementation, other probable cause may be added (see ITU-T Recommendation X.733 [25]).

#### **7.1.2.1.5 Quality of service**

No quality of service alarms are defined. Performance data relating to quality of service is defined in subclause 7.2 of this ETS. These data may be collected periodically from the OS which may generate alarms if required.



7.1.2.1.6 List of alarms probable cause

Table 1 provides a list of alarm conditions with corresponding perceived severity of the default value.

Table 1: List of alarm conditions

| Alarm type                            | Alarm condition: Probable cause    | mandatory (M)/ optional (O) | Perceived severity default value |
|---------------------------------------|------------------------------------|-----------------------------|----------------------------------|
| Comm.                                 | LOS 2 048/G.703 (note 1)           | M                           | Major                            |
|                                       | BVE                                | O                           | Pending                          |
|                                       | LOS 2 048/G.704 (note2)            | M                           | Critical                         |
|                                       | BVE aggregate                      | O                           | Pending                          |
|                                       | LOF                                | M                           | Critical                         |
|                                       | EXBER                              | O                           | Minor                            |
|                                       | RAI (bit 3 of TS0 NFAS)            | M                           | Minor                            |
|                                       | Remote AIS                         | O                           | Minor                            |
|                                       | Remote SFI                         | O                           | Minor                            |
|                                       | AIS                                | M                           | Minor                            |
|                                       | LMFA                               | M                           | Minor                            |
|                                       | RMAI (bit 6 of TS 16 MF 0)         | M                           | Minor                            |
|                                       | AIS TS16                           | M                           | Minor                            |
|                                       | Frame Slip                         | M                           | Pending                          |
|                                       | CRC4 Error                         | M                           | Pending                          |
|                                       | RCRC4 Error                        | M                           | Pending                          |
|                                       | None 2W/4W                         | -                           | None                             |
|                                       | None 7 kHz                         | -                           | None                             |
|                                       | Loss Of Signal 64 kbit/s           | M                           | Major                            |
|                                       | Loss of Octet Timing codirectional | O                           | Minor                            |
|                                       | Electrical failure X.24 (note 3)   | O                           | Major                            |
|                                       | Loss of Connection                 | O                           | Warning                          |
|                                       | Loss of DTE power                  | O                           | Warning                          |
|                                       | Loss of Connection V.24 (note 4)   | O                           | Warning                          |
|                                       | Loss of DTE power                  | O                           | Warning                          |
|                                       | LOS 2 048/G.704 (note2)            | M                           | Major                            |
|                                       | BVE tributary                      | O                           | Pending                          |
|                                       | LOF                                | M                           | Major                            |
|                                       | EXBER                              | O                           | Minor                            |
|                                       | RAI (bit 3 of TS0 NFAS)            | M                           | Minor                            |
|                                       | Remote AIS                         | O                           | Minor                            |
|                                       | Remote SFI                         | O                           | Minor                            |
|                                       | AIS                                | M                           | Minor                            |
|                                       | LMFA                               | M                           | Minor                            |
|                                       | RMAI (bit 6 of TS 16 MF 0)         | M                           | Minor                            |
|                                       | AIS TS16                           | M                           | Minor                            |
|                                       | Frame Slip                         | M                           | Pending                          |
|                                       | CRC4 Error                         | M                           | Pending                          |
|                                       | RCRC4 Error                        | M                           | Pending                          |
|                                       | LOS 2 048/G.703 (note 1)           | M                           | Major                            |
| BVE tributary                         | O                                  | Pending                     |                                  |
| Management link failure               | O                                  | Critical                    |                                  |
| External synchronization link failure | M                                  | Major                       |                                  |
| (continued)                           |                                    |                             |                                  |

Table 1 (concluded): List of alarm conditions

| Alarm type         | Alarm condition: Probable cause  | mandatory (M)/ optional (O) | Perceived severity default value |          |
|--------------------|--|-----------------------------|----------------------------------|----------|
| Equipment          | Power Supply Failure   | M                           | Critical                         |          |
|                    | Loss of synchronization  | M                           | Major                            |          |
|                    | Transmission circuits  | Interface Failure           | O                                | Major    |
|                    | Loss of internal Timing  |                             | O                                | Major    |
|                    | Loss of internal Power Feeding   | M                           | Major                            |          |
|                    | Common logic failure   | O                           | Minor                            |          |
|                    | XC interface failure   | M                           | Major                            |          |
|                    | XC failure   | XC                          | M                                | Critical |
|                    | XC CAS failure   | XC CAS                      | M                                | Major    |
|                    | Special function Failure   | SF                          | O                                | Major    |
|                    | Timing Failure   | MTS                         | M                                | Critical |
|                    | Failure of CPU   | Common                      | O                                | Critical |
|                    | Defect of program memory   | Logic                       | M                                | Major    |
|                    | Defect of Data memory  |                             | M                                | Major    |
|                    | Defect of internal power feeding   |                             | M                                | Critical |
| Processing         | Time management  | O                           | Minor                            |          |
|                    | Memory alarm   | M                           | Minor                            |          |
|                    | Database misalignment  | M                           | Major                            |          |
|                    | Downloading software error   | O                           | Major                            |          |
|                    | Software corruption  | M                           | Major                            |          |
| Environm.          | Fire   | O                           | Critical                         |          |
|                    | Door opening   | O                           | Major                            |          |
| Quality of service | To be defined  | O                           | To be determined                 |          |
| NOTE: 1            | G.703 refers to CCITT Recommendation G.703 [1].  |                             |                                  |          |
| NOTE: 2            | G.704 refers to CCITT Recommendation G.704 [2].  |                             |                                  |          |
| NOTE: 3            | X24 refers to CCITT Recommendation X.24 [20].  |                             |                                  |          |
| NOTE: 4            | V.24 refers to ITU-T Recommendation V.24 [17].   |                             |                                  |          |
| NOTE: 5            | The mandatory/optional column indicates if the corresponding alarm is mandatory or optional. |                             |                                  |          |

7.1.2.2 Perceived severity level

There are seven severity levels defined in ITU-T Recommendation X.733 [25] providing an indication of how it is perceived that the capability of the managed object has been affected.

The levels to be used in this context are listed and defined hereafter.

**cleared:** This level indicates the clearing of one or more previously reported alarms;

**indeterminate:** This level indicates that the severity level of the service affecting condition cannot be determined;

**critical:** This level indicates that a service affecting condition occurred and that an immediate correction action is required;

**major:** This level indicates that a service affecting condition occurred and that an urgent correction action is required;

**minor:** This level indicates the existence of a non-service affecting condition and that the correction action should be taken in order to prevent a more serious condition (e.g. a service affecting condition);

**warning:** This level indicates the detection of a potential or impeding service affecting condition, before any significant effect has been felt;

**pending:** This level indicates that some alarm condition has been recognized but has not persisted long enough to qualify as a non-transient condition (as determined by some algorithm applied to the alarm condition). This does not directly causes any alarm notification.

The equipment can provide some of these seven levels but not necessarily all of them.

### **7.1.2.3 Alarm record**

The FM equipment and its (local) management system shall provide an alarm record. An alarm record represents information stored in logs.

Each record should include at least the following parameters:

- managed functions;
- alarm type;
- perceived severity;
- probable cause;
- event time.

Optionally the record should include the "backed-up status" parameter. This parameter indicates whether or not the failed object has been backed up.

## **7.1.3 Test functions**

### **7.1.3.1 Loopbacks**

Part 1 (ETS 300 461-1 [31]), of this ETS describes the position and the applicable procedure for each interface in the "test function" paragraph of each interface description (see clauses 8 and 9).

Annex C of ETS 300 461-1 [31] provides information on the use of the different loopbacks.

### **7.1.3.2 Test devices**

#### **7.1.3.2.1 Data transmission testing**

The equipment may optionally provide facilities for data transmission testing. This function is made by means of test patterns such as:

- pseudo-random sequence  $2^{15} - 1$ ;
- pseudo-random sequence  $2^{20} - 1$ ;
- all ones;
- mostly ones (one byte zero, 255 byte ones);
- others.

#### **7.1.3.2.2 Analogue transmission testing**

The equipment may optionally provide facilities for analogue transmission testing. This function is made by the connection of the wires of the interface to a metallic test bus. The test device, is also connected to the metallic test bus when a test have to be performed.

### **7.1.3.3 Internal tests**

It is considered that monitoring functions for essential parts of the FM equipment should be provided. The parts concerned are:

- switch matrix (or equivalent);
- timing signals;
- power feeding;
- common logic;

- interface cards;
- TMN interfaces.

## 7.2 Performance management

The following subclauses refer to the monitoring of the quality of service on 2 048 kbit/s CCITT Recommendation G.704 [2] paths using the CRC4 procedure. Other methods for measuring performance of 2 048 Kbit/s CCITT Recommendation G.704 [2] signals irrespective of whether the CRC4 procedure is used, may be implemented.

Performance management is an application function for the FM equipment management. It applies to the 2 048 kbit/s digital path level only. It involves some computing functions on Anomaly Events (AE) or Defect Events (DE) which are listed hereafter. This function covers two different requirements related respectively to long term or short term performance evaluation.

The long term performance evaluation provides results according to ITU-T Recommendation G.826 [9]. For the FM application this is applicable to 2 048 kbit/s CCITT Recommendation G.704 [2] structured digital links (tributaries and aggregate).

The short term performance evaluation follows the principles described in ITU-T Recommendations M.20 [10], M.2100 [11], M.2110 [12] and M.2120 [13]. This is to be provided to cover at least the second of the two following situations where the equipment is involved:

- bringing into service a 2 048 kbit/s digital path (see note);
- maintenance of 2 048 kbit/s digital path in real operation (in service).

NOTE: Alternatively, a Pseudo Random Bit Sequence (PRBS) generator and analyser according to ITU-T Recommendation O.151 [16] may be used for the performance evaluation in the bringing-into-service situation.

### 7.2.1 Long term performance evaluation

The long term performance evaluation for CCITT Recommendation G.704 [2] framed 2 048 kbit/s signals is based on ITU-T Recommendation G.826 [9]. For this evaluation, the following parameters are considered and corresponding definitions are given in subclause 7.2.4:

- errored block (EB);
- errored second (ES);
- severely errored second (SES);
- background block error (BBE).

The associated computing functions are limited to the calculation of current ratio for ES, SES and BBE parameters and identified as:

- errored second ratio (ESR);
- severely errored second ratio (SER);
- background block error ratio (BBER).

The accumulation of performance parameters and associated ratio calculation should be made on a long term basis (e.g. 3 months or more). This does not preclude intermediate evaluation under request of the Operation System but this is not considered as a mandatory function. Comparison of the long term performance evaluation with the performance allocated to a given 2 048 kbit/s digital path and to the specified limits for ESR, SER and BBER are not considered as a management function for the FM.

Figure 13 depicts corresponding long term performance evaluation functions.

### 7.2.2 Short term performance evaluation

The associated computing function requires four levels of analysis. The first one concerns the detection of elementary events which are necessary for performance management. The second level realizes a statistical calculation based on a one second time period in order to classify each second as Normal, Errored Second (ES) or Severely Errored Second (SES). Then, a notification module will provide the necessary information to the fourth level where the corresponding quality of service is determined,

individually per 2 048 kbit/s access port and for the received signal (optionally for the transmit signal). The performance evaluation is only applicable for the period of time where the digital path is available.

### **7.2.2.1 Elementary events for in-service measurement**

Elementary events affecting the performance of 2 048 kbit/s digital paths are classified into Anomaly Events (AE) or Defect Events (DE) according to ITU-T Recommendation M.20 [10].

#### **7.2.2.1.1 Anomaly Event (AE), receive part**

The following event shall be detected:

- BE: CRC4 code word violation (Errored CRC4 block).

#### **7.2.2.1.2 Anomaly Event (AE), transmit part**

The following event shall be detected:

- reception of E bit.

#### **7.2.2.1.3 Defect Events (DE), receive part**

The following events shall be detected:

- Loss of Frame Alignment (LOF);
- Loss of Signal (LOS).

#### **7.2.2.1.4 Defect Events (DE), transmit part**

The following event shall be detected:

- bit 3 of TS0 NFAS.

### **7.2.2.2 Elementary events for out-of-service measurement**

The usefulness of having a test function inside the equipment able to generate/analyse PRBS for the purpose of out-of-service performance measurement depends on the maintenance strategy of the operator. When providing this function, the equipment is able to generate unframed 2 048 kbit/s, framed 31 x 64 kbit/s (or 30 x 64 kbit/s in case of 2 048 kbit/s signals carrying channel associated signalling) PRBS signals at the level of a number of 2 048 kbit/s interfaces (see subclause 7.1.3).

The out-of-service performance measurement concerns either a bringing-into-service situation or a test process following a failure condition and restoration in a point-to-point configuration or on a remote loopback (refer to subclause 7.1.3.1).

### **7.2.3 Condition of measurement**

The final performance evaluation shall only be processed when the 2 048 kbit/s digital path is in the available time, i.e. disabled when determined in Unavailable Time (UT).

#### **Definition of Unavailable Time:**

The 2 048 kbit/s digital path is said to be in UT at the outset of 10 consecutive SES according to the following figure 5. A 2 048 kbit/s digital path is considered in an unavailable state if one or both directions are in the unavailable state.

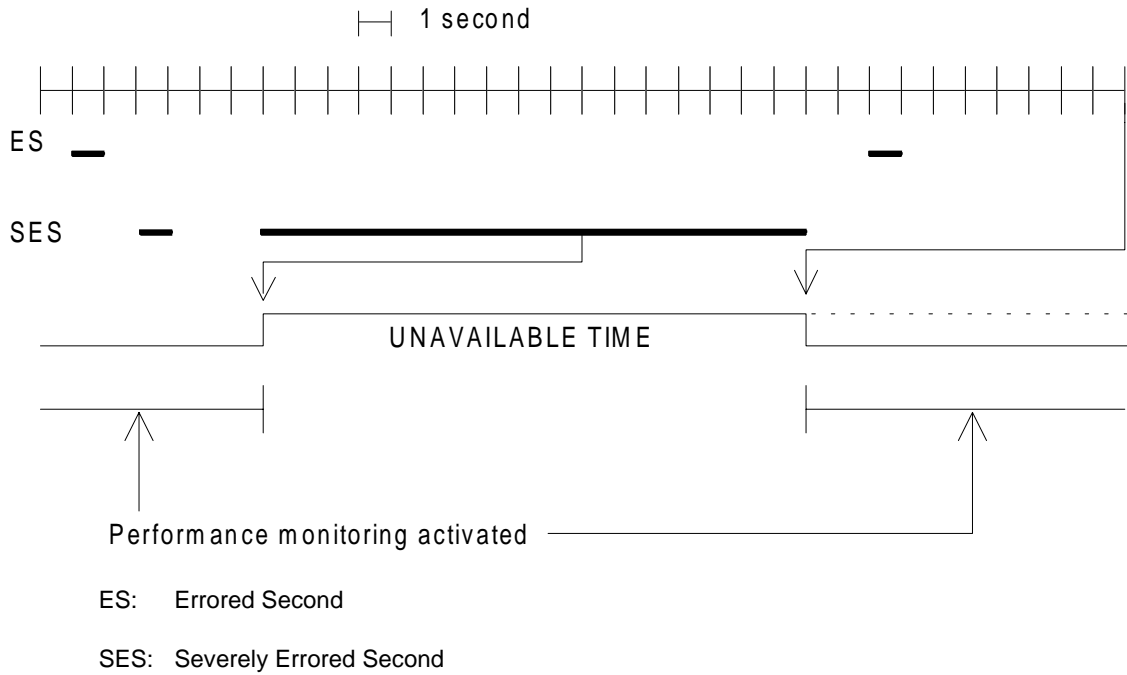

**Figure 5: Definition of unavailable time**

The criterion to determine if one particular second is SES is given in table 2.

**7.2.4 Performance parameters evaluation**

In addition to the detection of an AE and DE (first level of the performance evaluation), the equipment shall be able to provide in-service performance parameters according to table 2.

The in-service performance parameters to be considered for a 2 048 kbit/s digital path using the CRC4 procedure are given in table 2.

**Table 2: In-service performance parameters with CRC4**

| Path level             | POH available to derive AE/DE data | AE/DE per second   | Interpretation for receive direction | Interpretation for transmit direction |
|------------------------|------------------------------------|--------------------|--------------------------------------|---------------------------------------|
| 2 048 kbit/s WITH CRC4 |                                    | >= 1 LOF           | ES + SES                             |                                       |
|                        |                                    | >= 1 LOS           | ES + SES                             |                                       |
|                        |                                    | >= 1 CRC4 error(s) | ES                                   |                                       |
|                        | CRC4                               | >= 805 CRC4 errors | ES + SES                             |                                       |
|                        | E-bit                              | >= 1 E-bit         |                                      | ES                                    |
|                        | FAS                                | >= 830 E-bit       |                                      | ES + SES                              |
|                        | A-bit                              | >= 1 A-bit         |                                      | ES                                    |
|                        |                                    | >= D A-bit         |                                      | ES + SES                              |

**A bit:** bit 3 of TSO NFAS = Remote alarm indication.

**E bit:** remote CRC error (Transmitted in the CRC multiframe).

**D:** value under study at the ITU-T Recommendation M.2100 [11] level.

According to ITU-T Recommendation G.826 [9], a Background Block Error BBE is defined as an errored CRC4 block error not occurring as part of an SES. The BBE notion is applicable only for the receive direction.

**7.2.5 Performance process**

The ES and SES are counted individually in two counters C1 and C2 for the 15 minute basis evaluation process and in two counters C3 and C4 for the 24 hour basis evaluation process.

**7.2.5.1 15 minute process**

ES and SES performance parameters are transmitted to the two counters C1 and C2 as indicated in figure 6. These two counters are reset at the beginning of every 15 minute calculation period. TR1ES and TR1SES thresholds are associated respectively to counters C1 and C2. Figure 7 depicts the mechanism for calculating the number of received performance parameters and consequent actions within each period of 15 minutes.

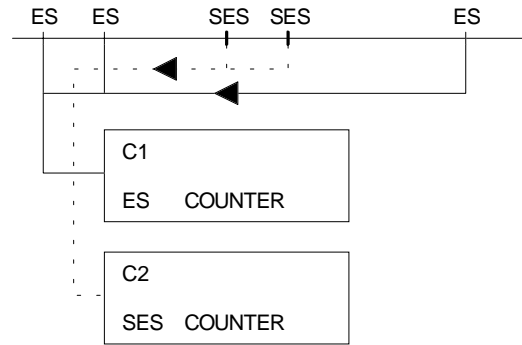

**Figure 6: Counting of performance parameters**

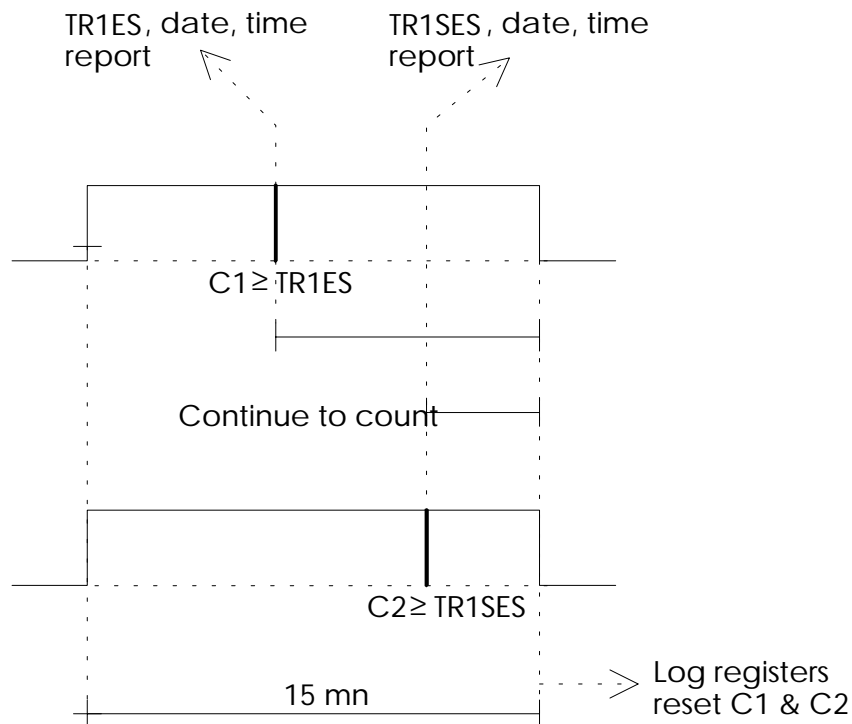

**Figure 7: Consequent actions**

Two options described hereafter are allowed for the 15 minute evaluation process.

**7.2.5.1.1 Option 1 - Evaluation without hysteresis**

When the content of counter C1 or counter C2 exceed respectively the thresholds TR1ES or TR1SES in a given 15 minute time period, a time and date stamped report is sent. The two counters continue to count

the ES or SES performance parameters they receive. At the outset of every 15 minute time period reports including the content of the two counters C1 and C2 are sent to the log file. This is depicted in figure 8.

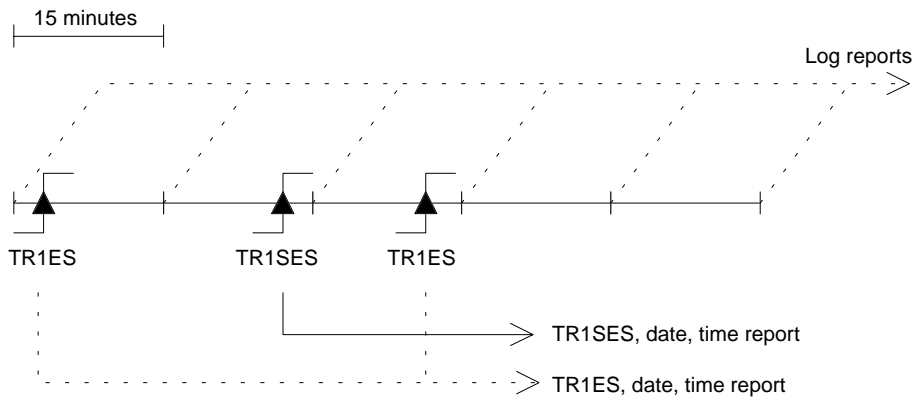

Figure 8: Performance evaluation process without hysteresis

7.2.5.1.2 Option 2 - evaluation with hysteresis

The ES counter (C1) has two thresholds TR1ES and W, where W is not greater than TR1ES. The SES counter (C2) has two thresholds TR1SES and 0.

When the content of C1 exceeds TR1ES within a period of 15 minutes, a TR1ES date and time stamped report is sent. There is no additional report sent during the following 15 minute periods until a 15 minute time with content of C1 not greater than W occurs. Then a Reset TR1ES report is sent.

When the content of C2 exceeds TR1SES within a period of 15 minutes, a TR1SES date and time stamped report is sent. There is no additional report sent during the following 15 minute periods until a 15 minute time with content of C2 equal to 0 occurs. Then a Reset TR1SES report is sent. Figure 9 depicts this mechanism.

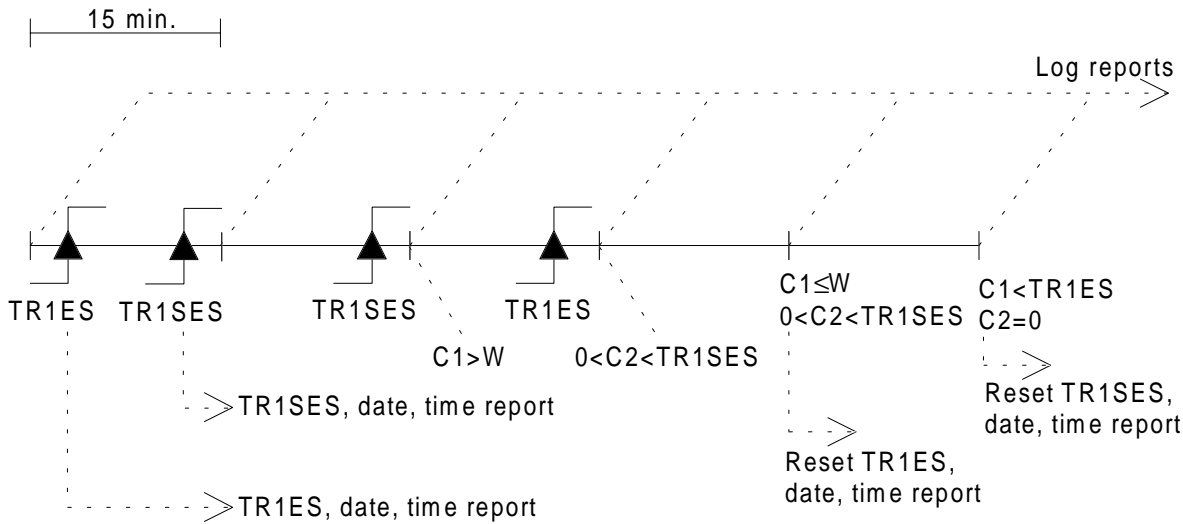
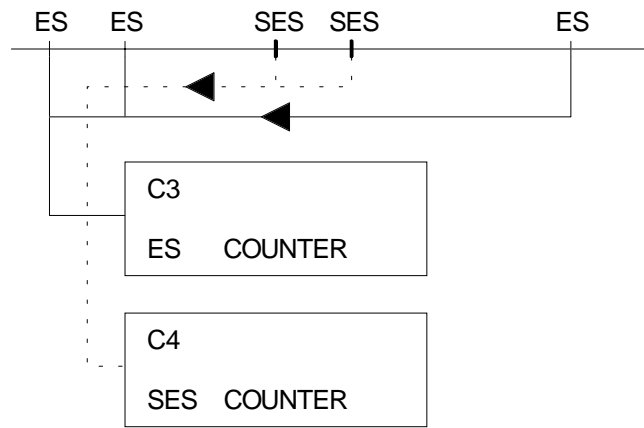

Figure 9: Performance evaluation with hysteresis

7.2.5.2 24 hour process

ES and SES performance parameters are transmitted to the two counters C3 and C4 as indicated in figure 10. These two counters are reset at the outset of every 24 hour accumulation time. TR2ES and TR2SES thresholds are associated respectively to counters C3 and C4. Figure 11 depicts the mechanism of accumulation of received performance parameters and consequent actions within each period of 24 hour.





**Figure 10: Counting of performance parameters**

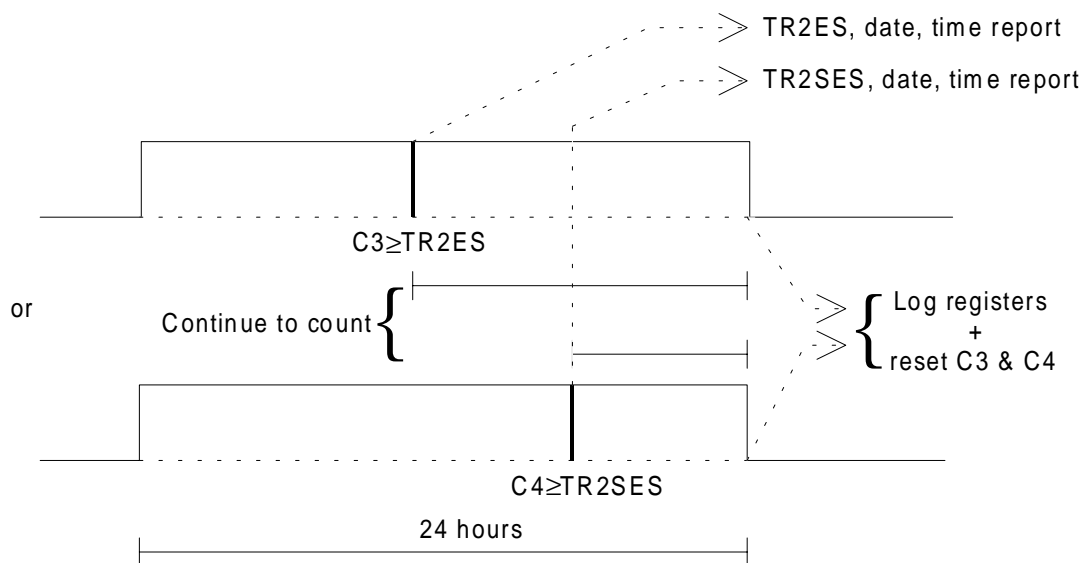

**Figure 11: Consequent actions**

When the content of C3 exceeds TR2ES within a period of 24 hours, a TR2ES date and time stamped report is sent. There is no additional report sent during the 24 hour period.

When the content of C4 exceeds TR2SES within a period of 24 hours, a TR2SES date and time stamped report is sent. There is no additional report sent during the 24 hour period.

**7.2.6 Performance evaluation**

The various states of a particular 2 048 kbit/s digital path in term of performance evaluation are:

- NP: Normal Performance;
- DP: Degraded Performance;
- UP: Unacceptable Performance.

The performance evaluation is derived from the thresholds (and optionally the reset thresholds reports) provided by the 15 minute and 24 hour processes described in subclauses 7.2.5.1 and 7.2.5.2. This is not standardized within this ETS.

**7.2.7 General performance functional diagram**

Figures 12 and 13 show the general performance diagrams.

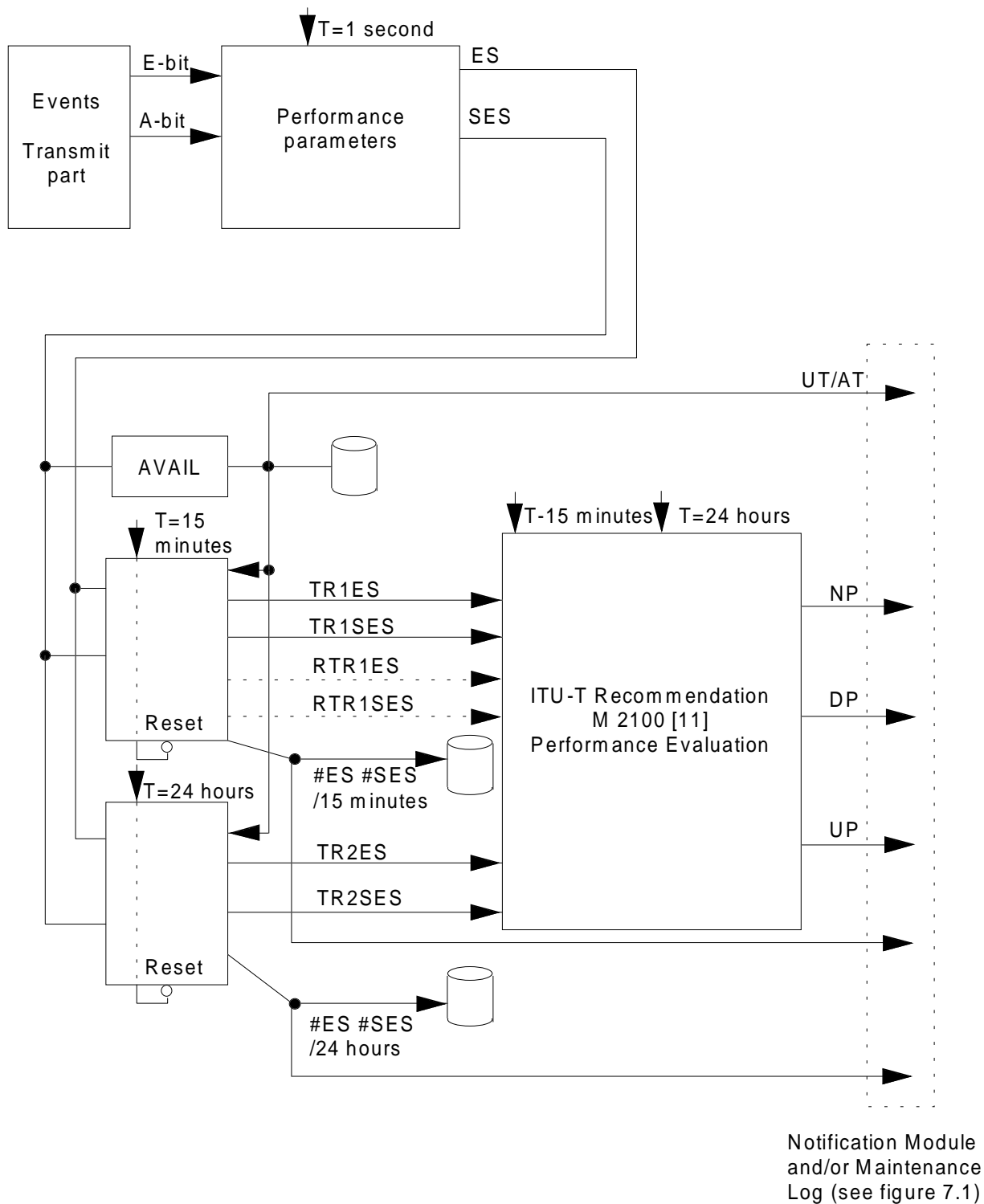

Figure 12: General performance diagram - transmit part



### 7.3 Configuration management

The configuration management is a management application that:

- can add new resources to the FM;
- can delete resources from the FM;
- can notify the creation or deletion of a resource;
- can query on the configuration and notifications of the resources;
- can list the attributes of the resources;
- can modify the attributes of the resources.

#### 7.3.1 Configuration management overview

##### 7.3.1.1 Functional architecture

This sub-clause presents the functional blocks of part 1 for the PDH access network according to the concepts of draft ITU-T Recommendation G.805 [8] and ETR 241 [32]. An example of the layering is shown in figure 14.

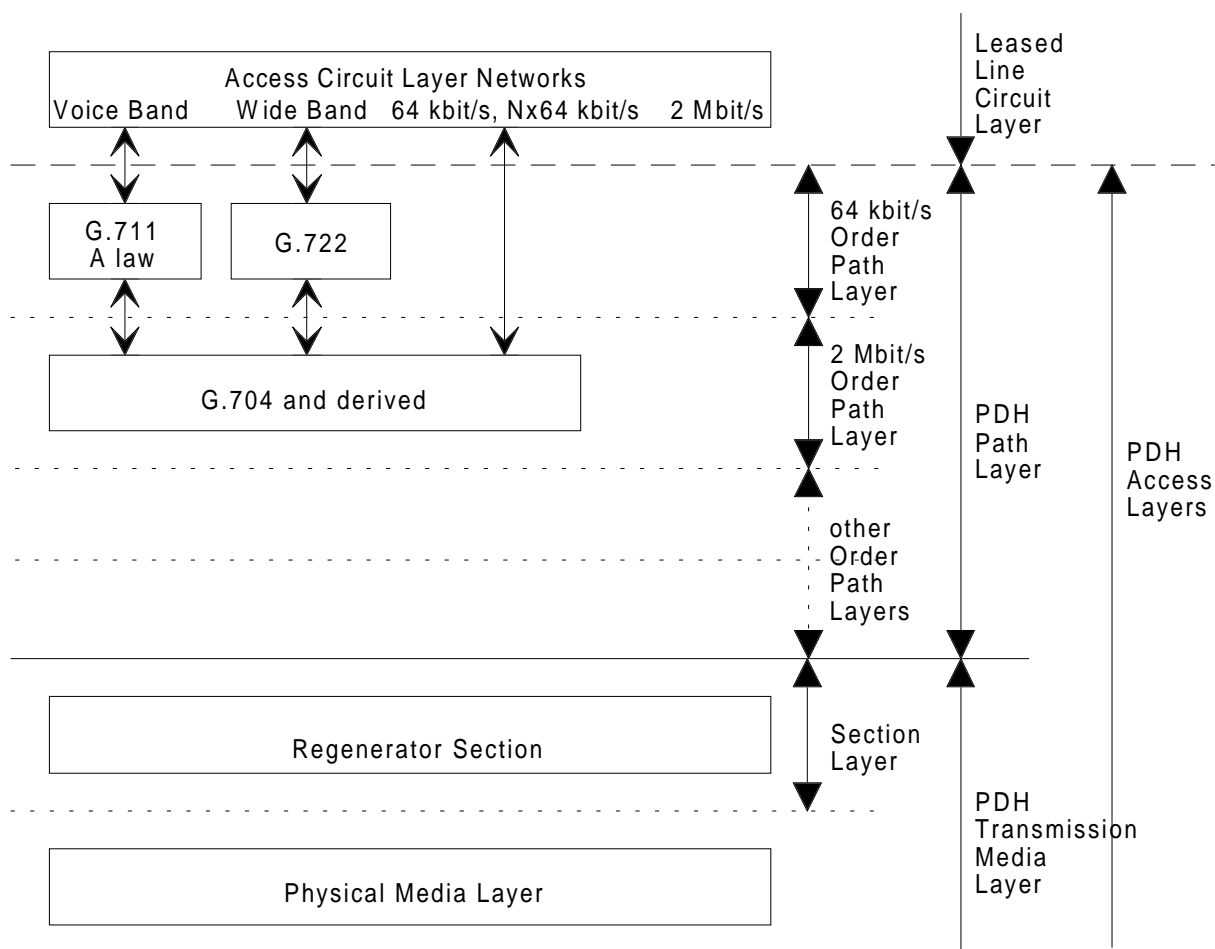

G.704: CCITT Recommendation G.704 [2]

G.711: CCITT Recommendation G.711 [3]

G.722: CCITT Recommendation G.722 [4]

**Figure 14: Example of PDH Access Network Layers**

Objects terminating the regenerator section are not part of this ETS.

Sub-64 kbit/s signals are not precluded and considered as an option that may be described according to the same methodology. Special functions like ADPCM and conference bridge etc. are also out of the scope of this ETS.

NOTE: The objects to be managed are indicated by grey shading with names in *italic bold*.

7.3.1.1.1 Main functions

Figures 15 to 18 present the main functions of the FM.

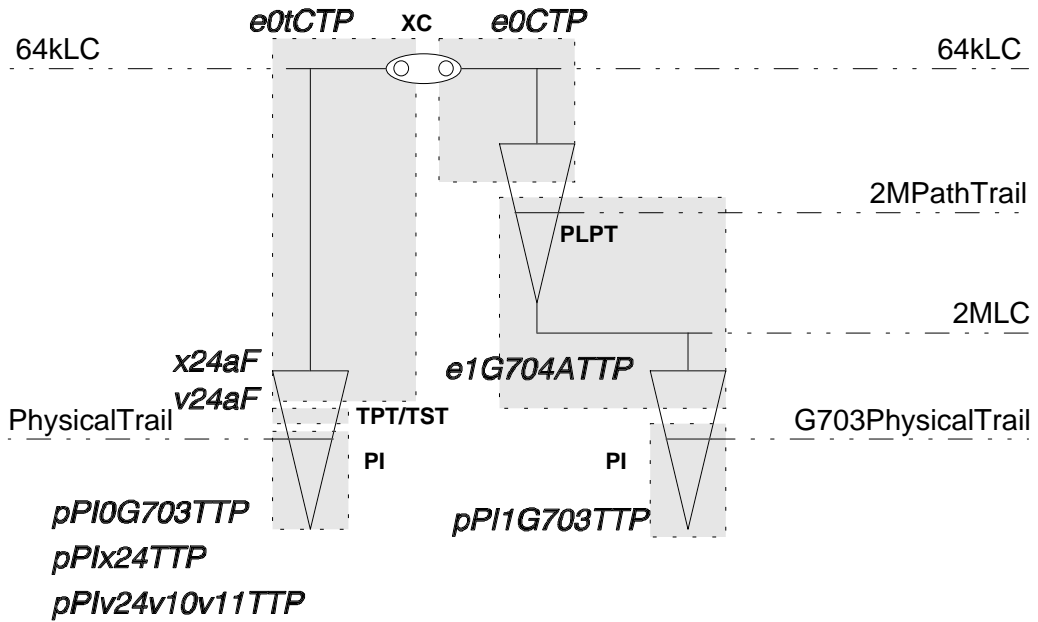

Figure 15: 64 kbit/s cross-connection between tributary and aggregate

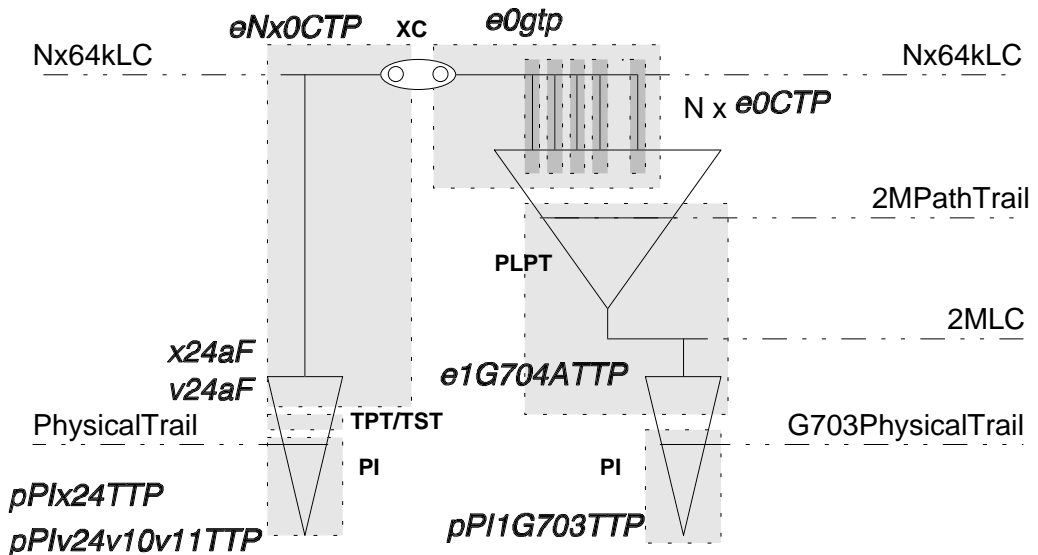

Figure 16: N x 64 kbit/s cross-connection between tributary and aggregate

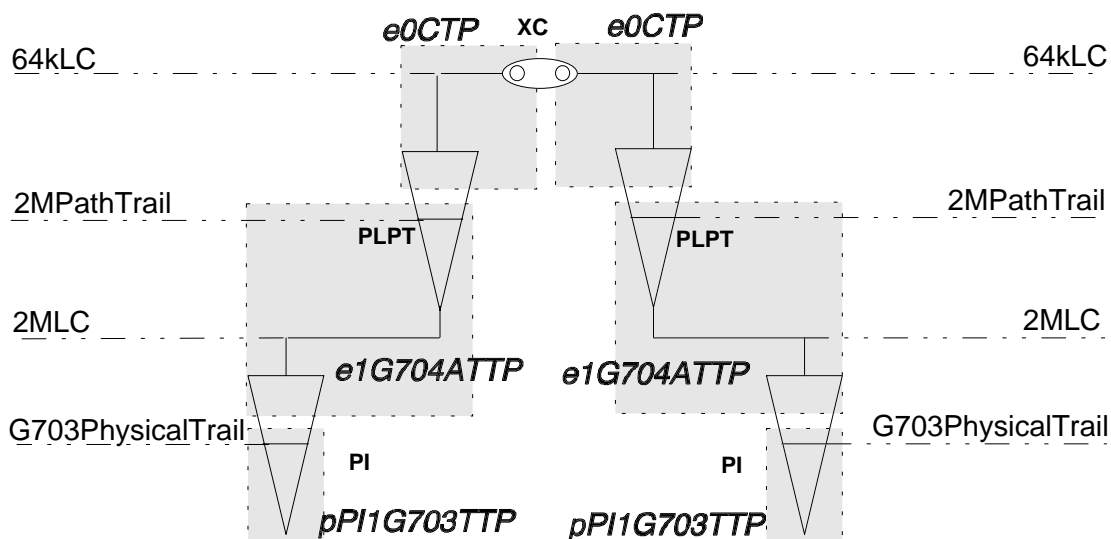

Figure 17: 64 kbit/s cross-connection between ITU-T Recommendation G.704 [2] tributary and aggregate

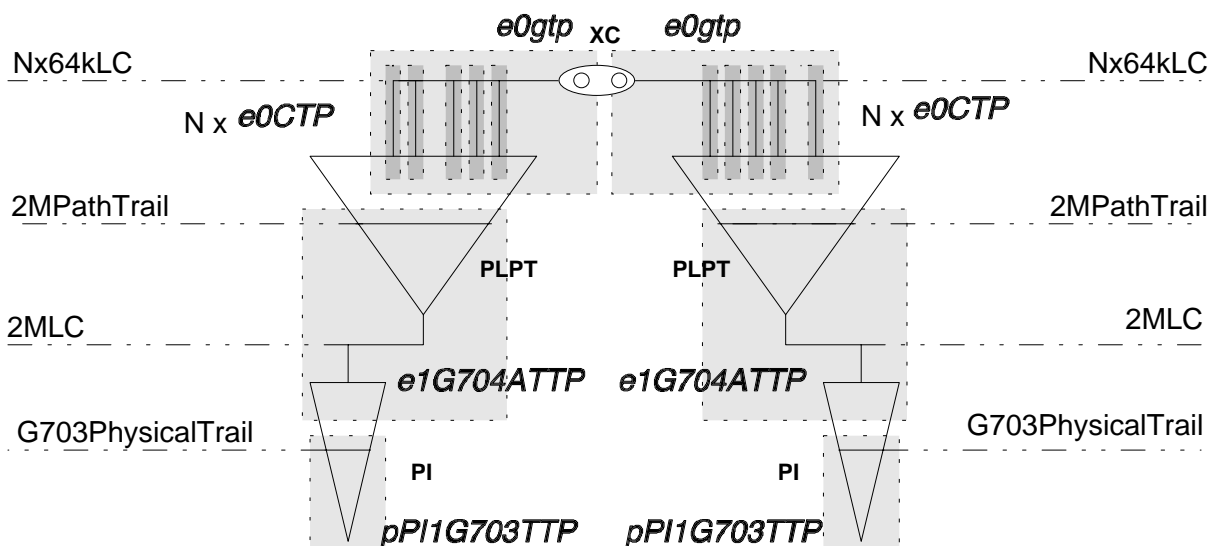

Figure 18: N x 64 kbit/s cross-connection between ITU-T Recommendation G.704 [2] tributary and aggregate

7.3.1.1.2 CAS cross-connection functions

Figures 19 to 21 present the CAS cross-connection functions of the FM. These functions are described following the annex D of ETS 300 376-1 [30].

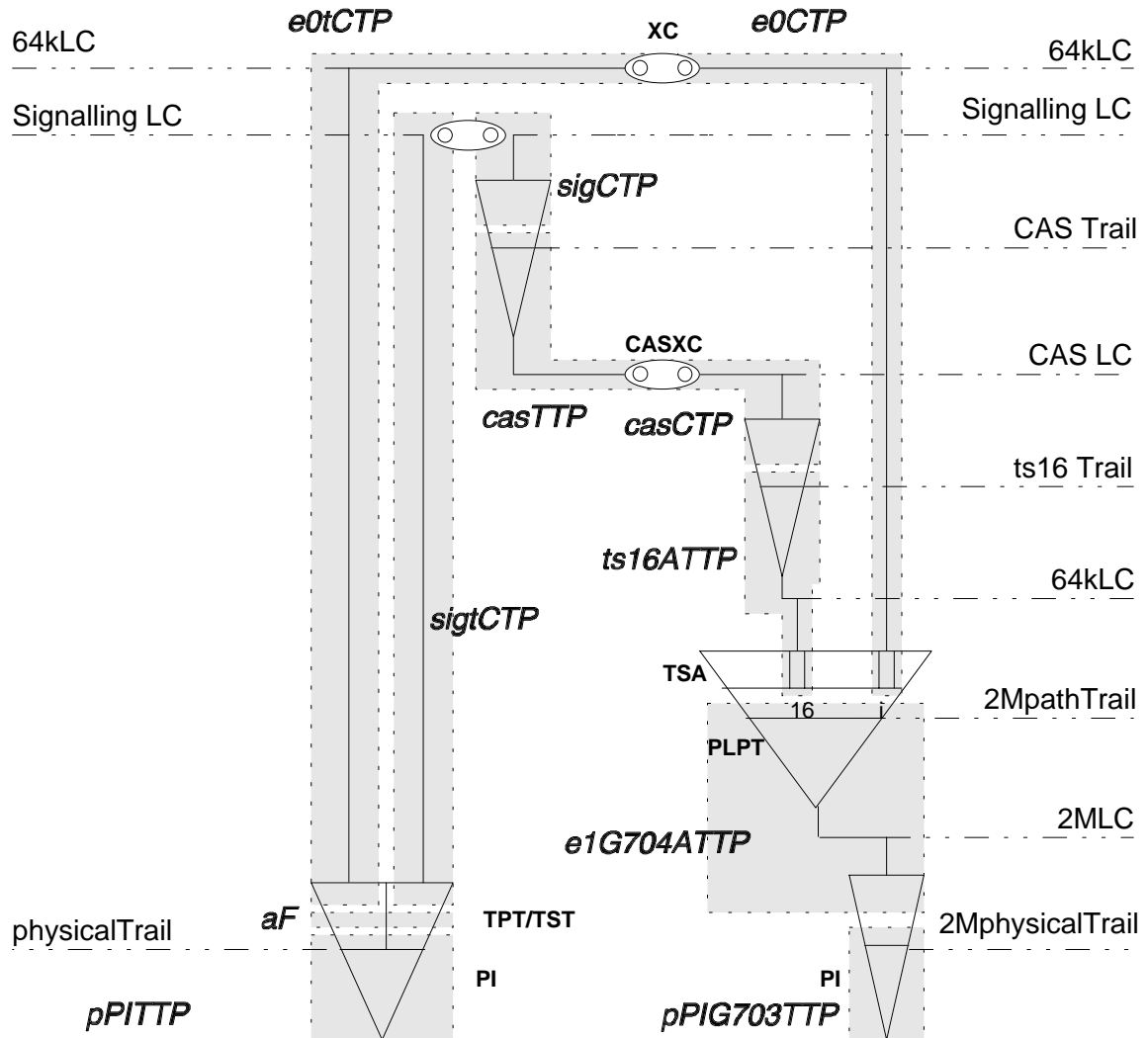

Figure 19: CAS cross-connection between tributary and aggregate

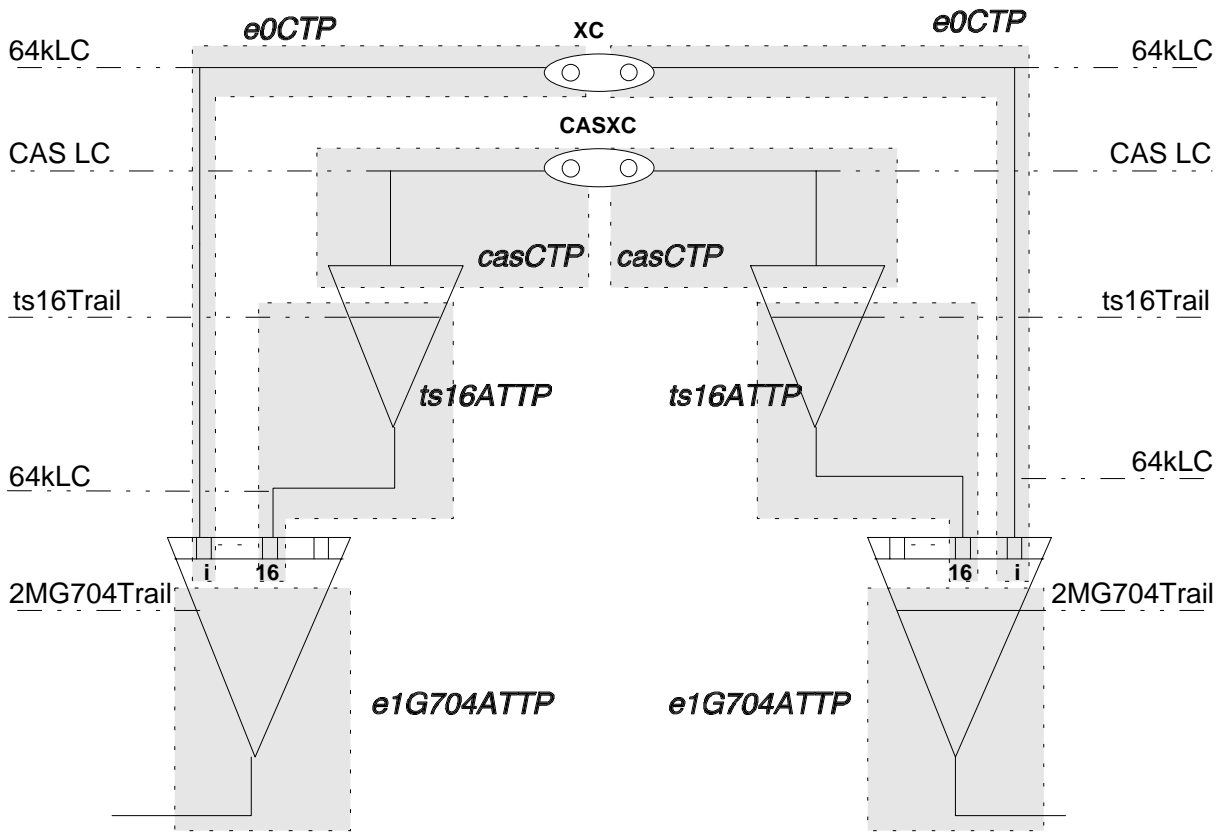

Figure 20: CAS cross-connection between CCITT Recommendation G.704 [2] tributary and aggregate

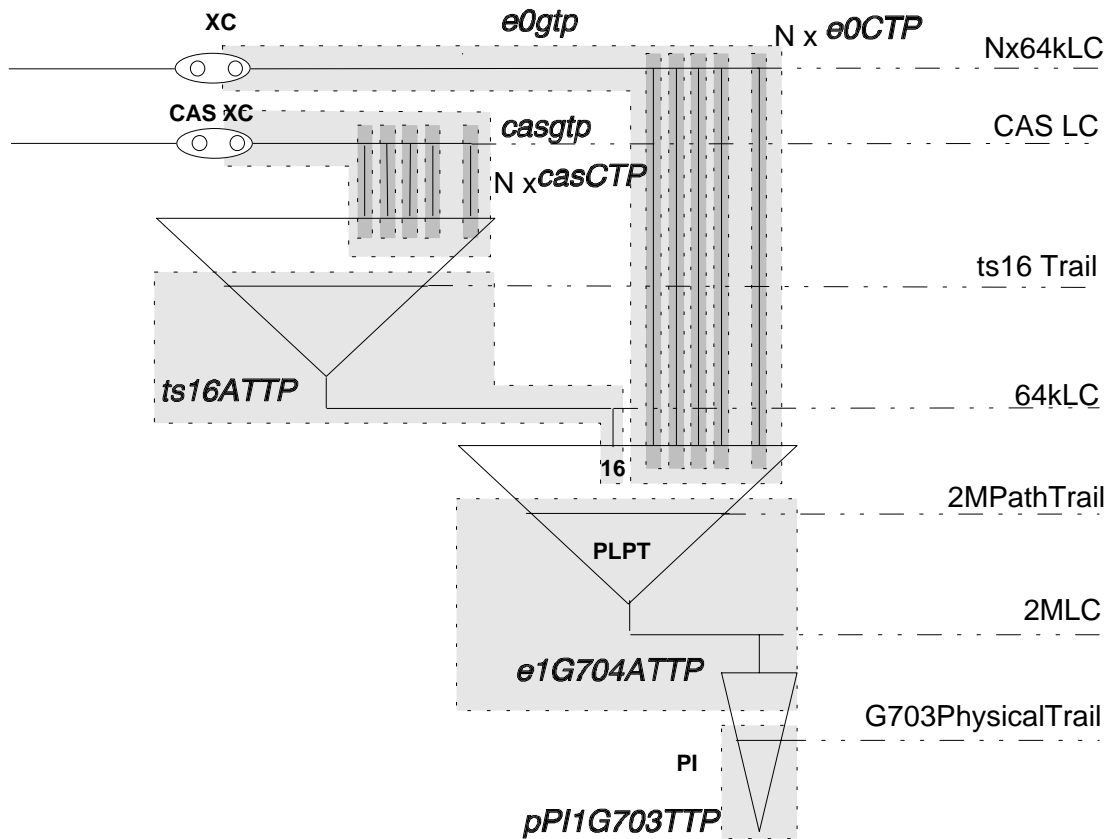

Figure 21: CAS for N x 64 kbit/s link connection on aggregate



7.3.1.1.3 Lower order section protection function

Figure 22 presents the lower order section protection function of the FM. This function is described following the ETS 300 304 [28] (protection unit and protection group, annex C, figures 10 to 14).

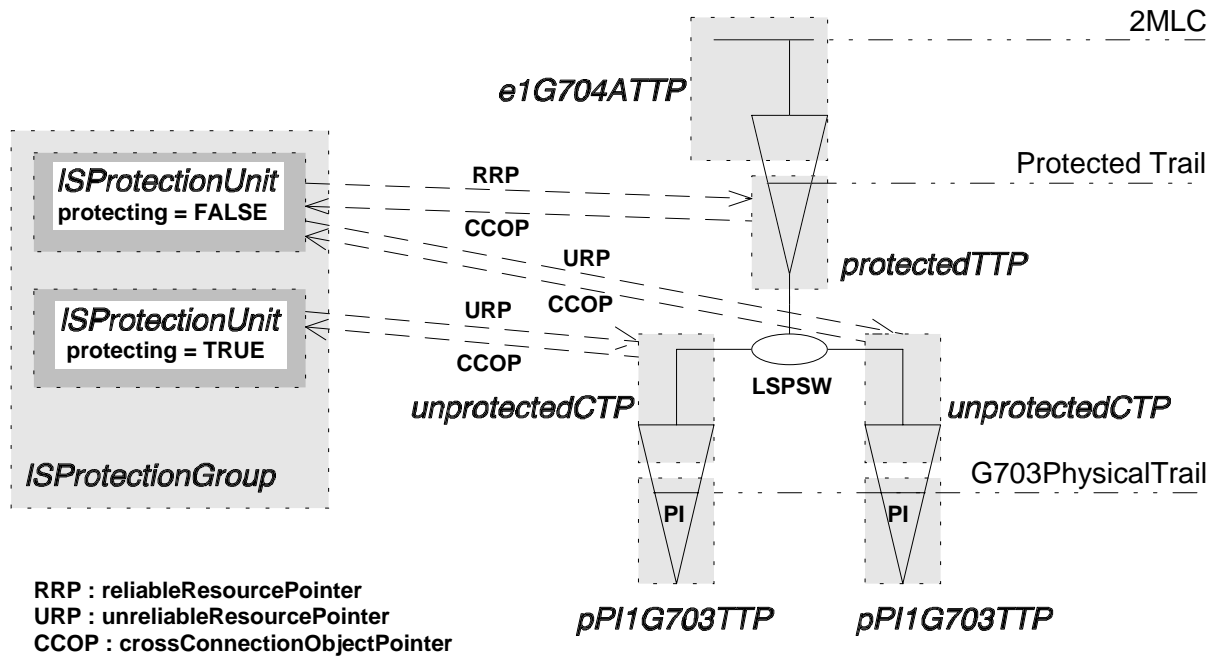

Figure 22: Lower order section protection switch (1+1)

7.3.1.1.4 Lower order path protection functions

Figures 23 and 24 present the lower order path protection functions of the FM. These functions are described following the ETS 300 304 [28] (protection unit and protection group, annex C, figures 10 to 14).

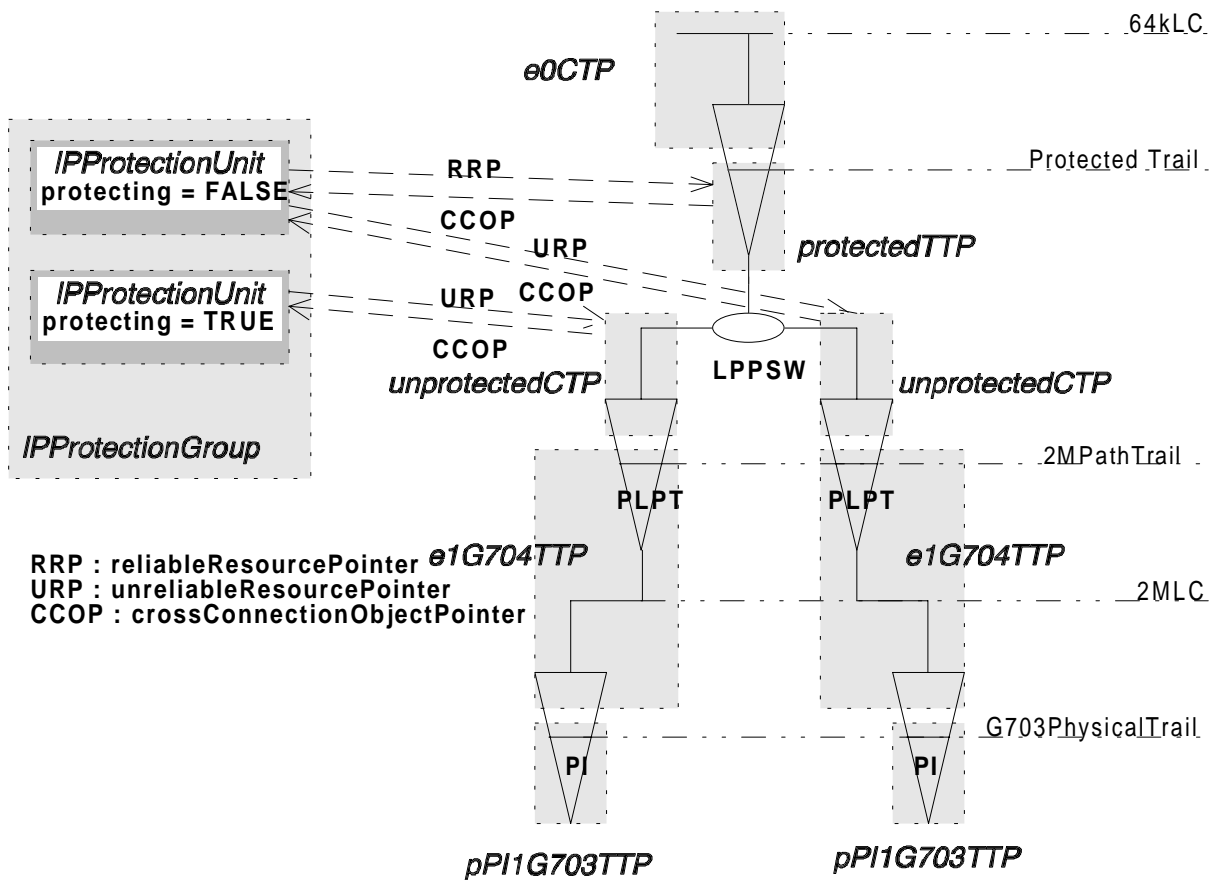

Figure 23: Lower order path protection switch (1+1)

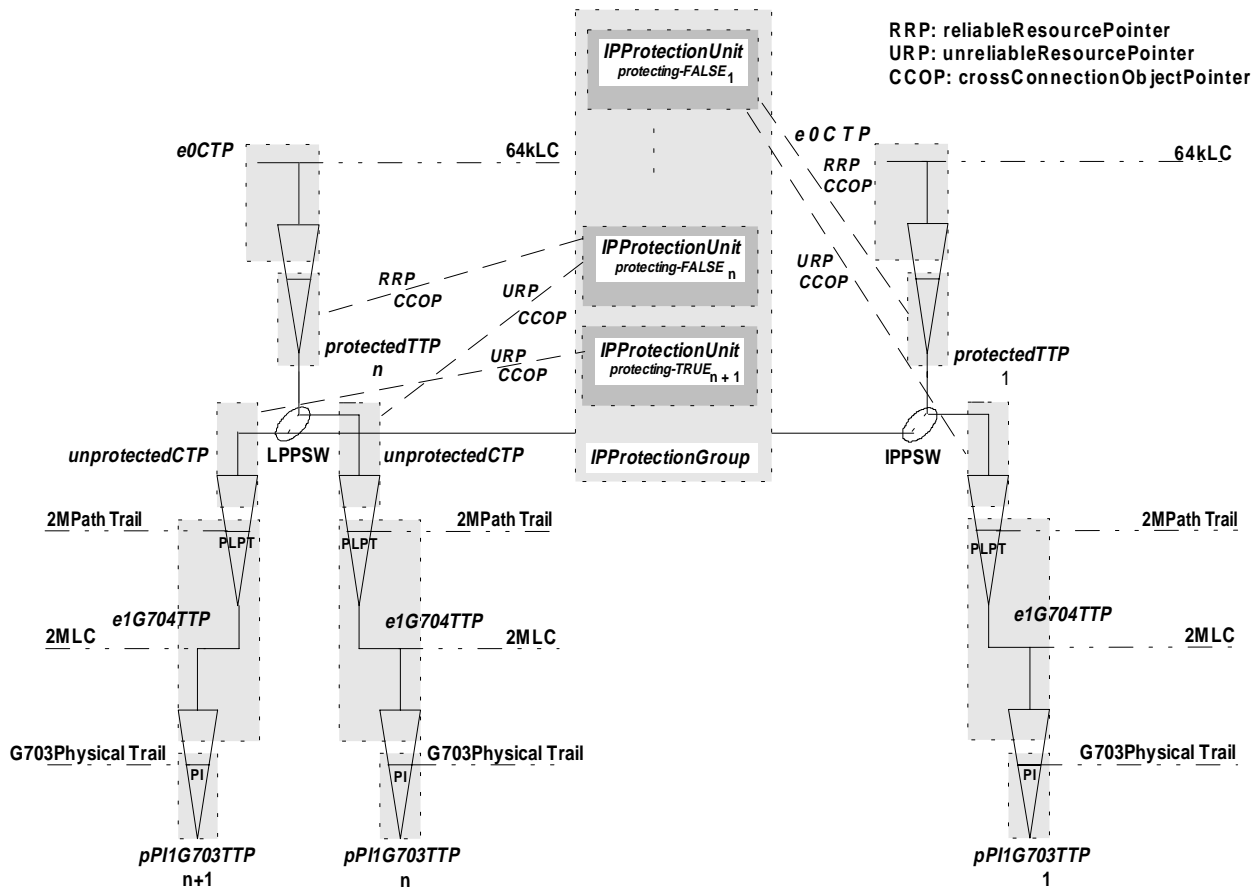

Figure 24: Lower order path protection (1:n)

7.3.1.1.5 Tributary signal adaptation functions

Figures 25 to 28 present the tributary signal adaptation functions of the FM.

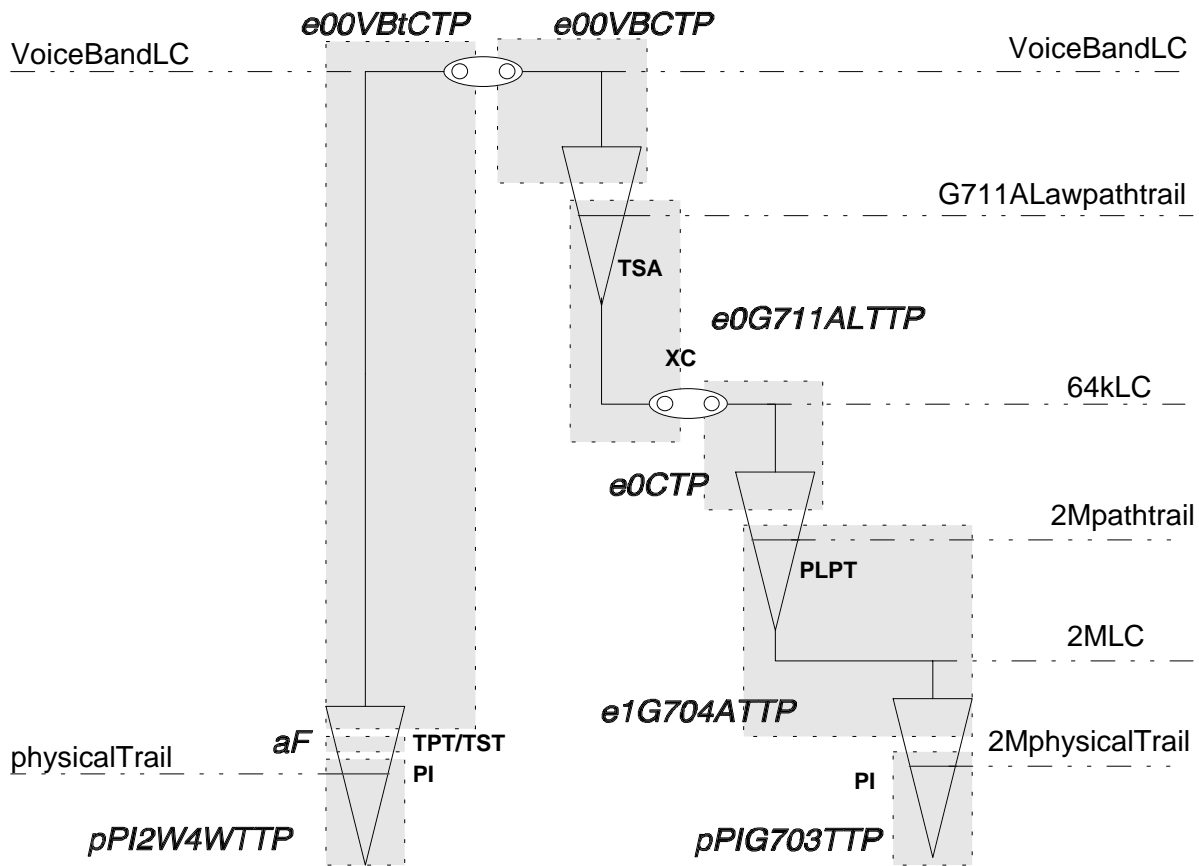

Figure 25: 2W/4W voice band signal adaptation

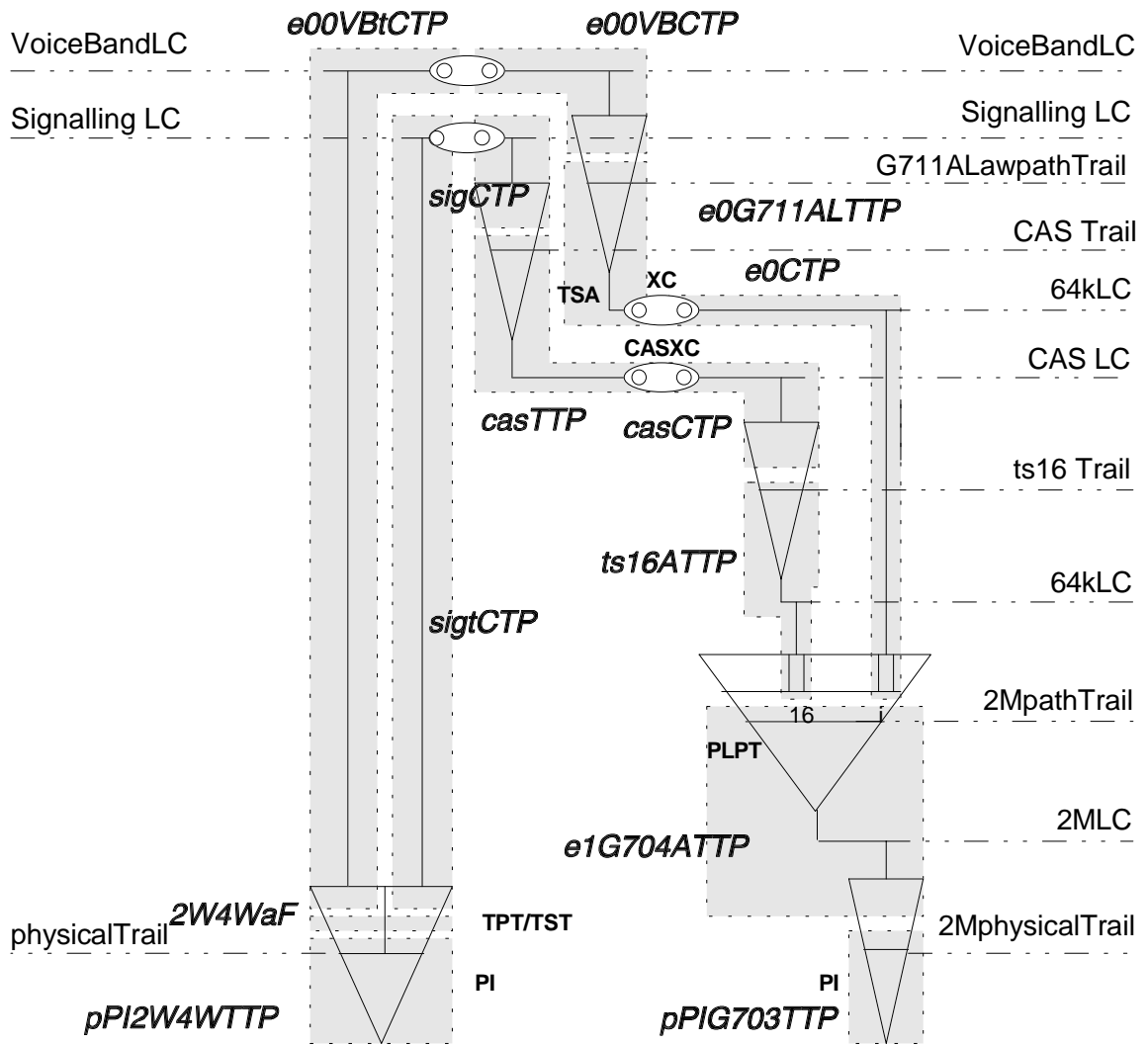

Figure 26: 2W/4W voice band signal adaptation with DC signalling

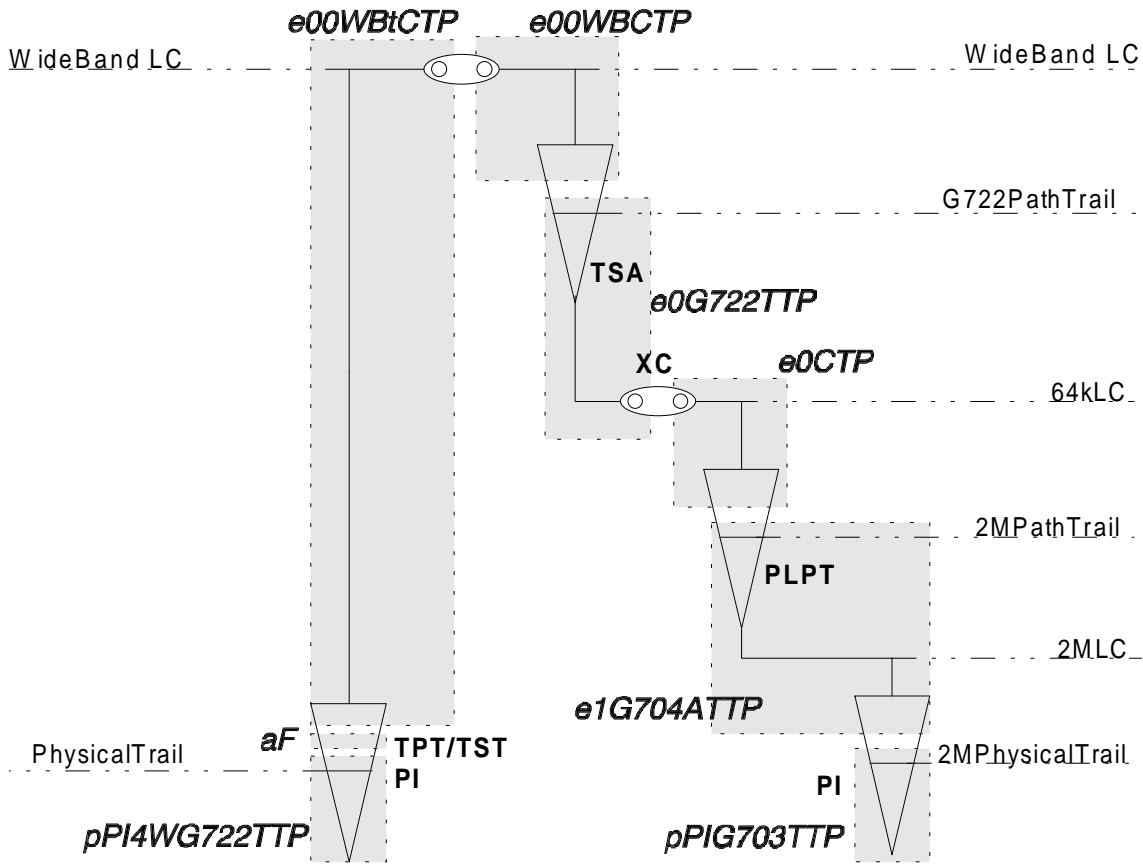

Figure 27: Wide band signal adaptation

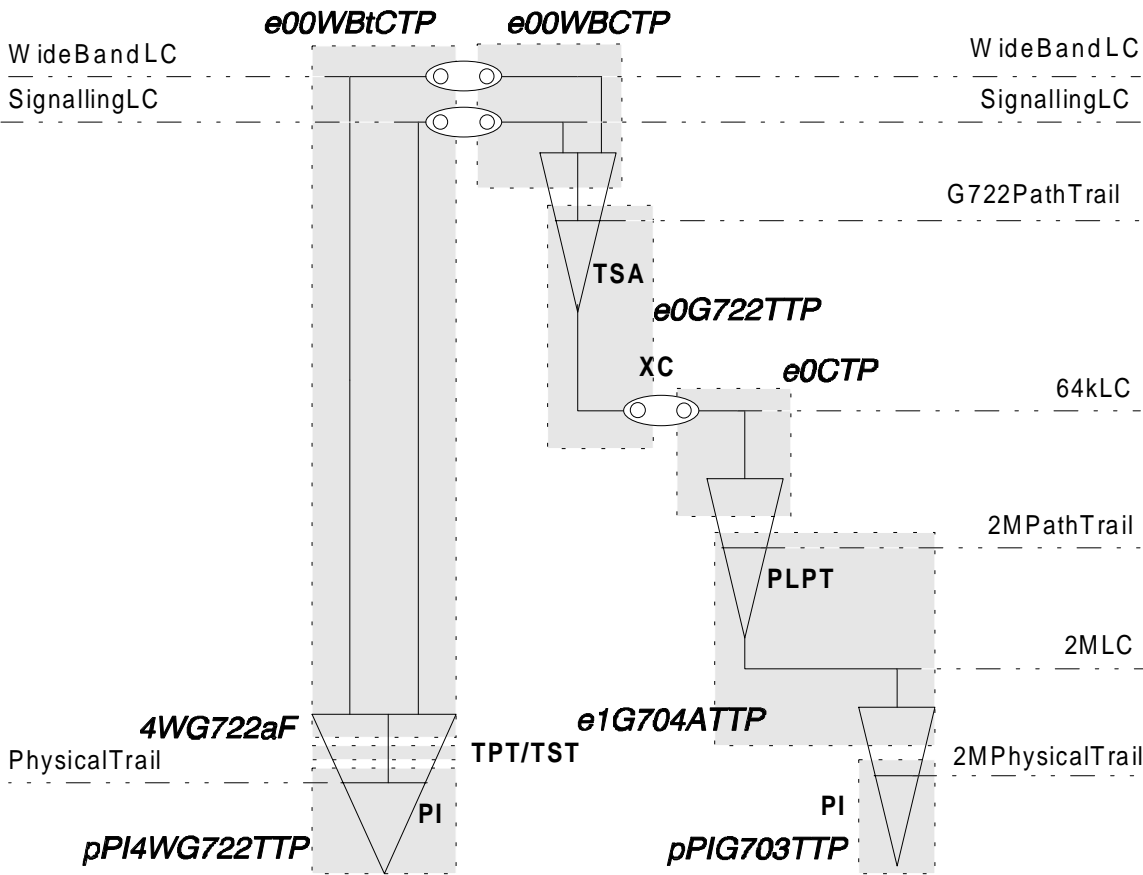
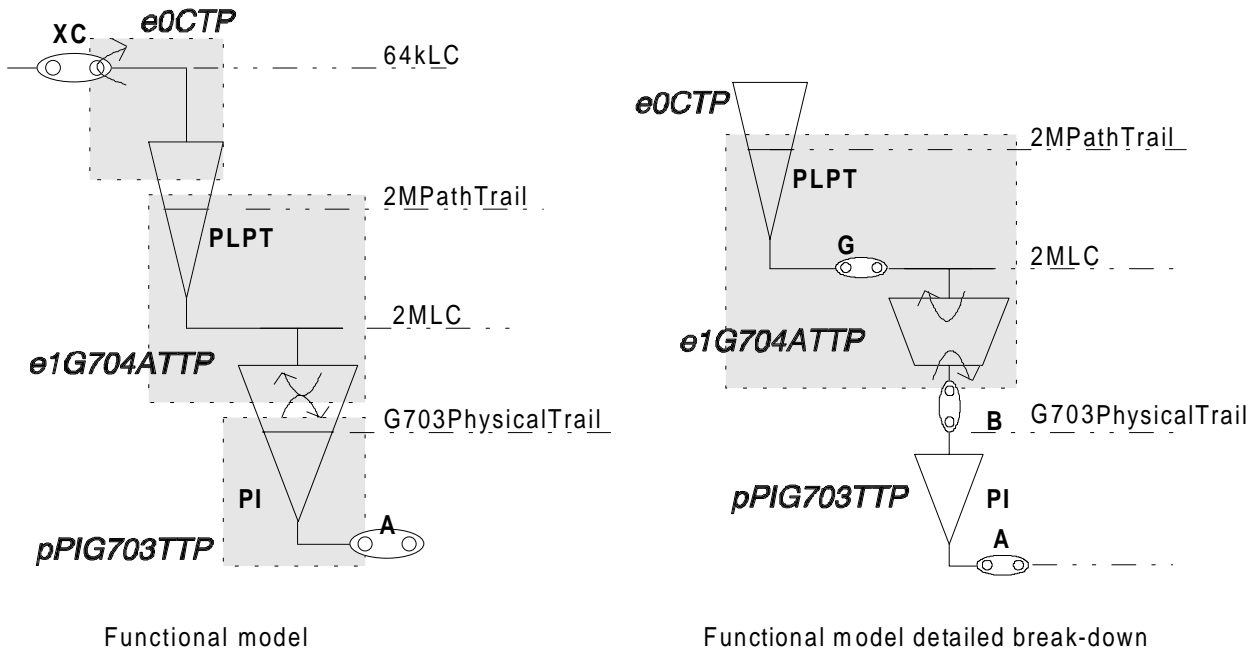

Figure 28: Wide band signal adaptation with signalling



A) Loop-backs of digital aggregate and tributary interfaces

Loop-backs in aggregate interface and core function



- XC: 64 or n x 64 kbit/s loop-back to the 2M interface (ETS 300 461-1 [31] subclause 7.7)
- G: 2 Mbit/s loop-back to the equipment (ETS 300 461-1 [31] subclause 8.2.1.8)
- B: 2 Mbit/s loop-back to the interface (ETS 300 461-1 [31] subclause 8.2.1.8)

**Figure 31: n x 64 kbit/s and 2 Mbit/s loop-backs**

A connection point B and G is for the looping 2M signal back to CCITT Recommendation G.703 [1] interface or back to CCITT Recommendation G.704 [2] path trail termination. The 64 kbit/s and n x 64 kbit/s loops (back to aggregate) are made in the XC connection point.

It should be noted that a 2 Mbit/s loop-back may block the EOC and synchronization and therefore a time out should be applied or there should be a back up EOC channel not dependent on that aggregate.

After the loop-back control settings has been terminated in XC the valid cross connection settings should be automatically restored.



**Loop-backs in the 64 kbit/s tributary interface**

The 64 kbit/s interface and equipment loop-backs can be made in reference point O according to ETS 300 461-1 [31].

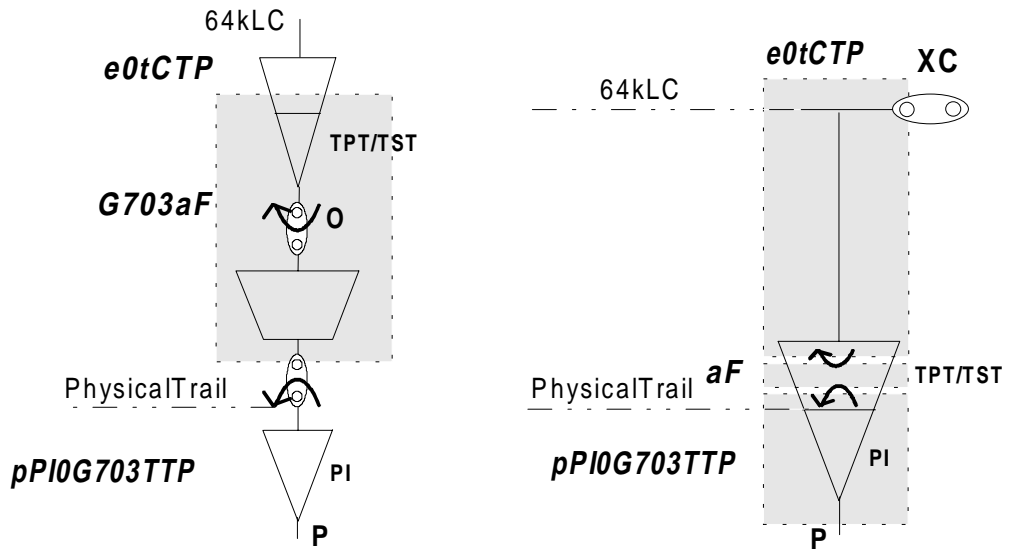

Functional model detailed break-down

Functional model

O: Local/remote loop-back (interface/equipment loop-back)

**Figure 32: Modelling of the CCITT Recommendation G.703 [1] 64 kbit/s tributary interface loop-backs**

**B) Data interface loop-backs as explained in annex C of ETS 300 461-1 [31] (CCITT Recommendation V.54 [19], CCITT Recommendation X.150 [21])**

A connection point O is for the CCITT Recommendation X.150 [21] or CCITT Recommendation V.54 [19] tributary interface loop-back 2b and equipment loop-back 3c. Interface loop-back 3b and equipment loop-back 4b are done at the XC connection point.

Loop-backs can be controlled according to CCITT Recommendation X.150 [21] or CCITT Recommendation V.54 [19] protocols by the end user or by the network manager. Loops can be activated only when allowed by configuration. Loops 3c and 2b shall be able to be activated at the same time. The loops made at XC shall not change the cross connection settings at XC but they should be restored automatically after the loop controls have been terminated.

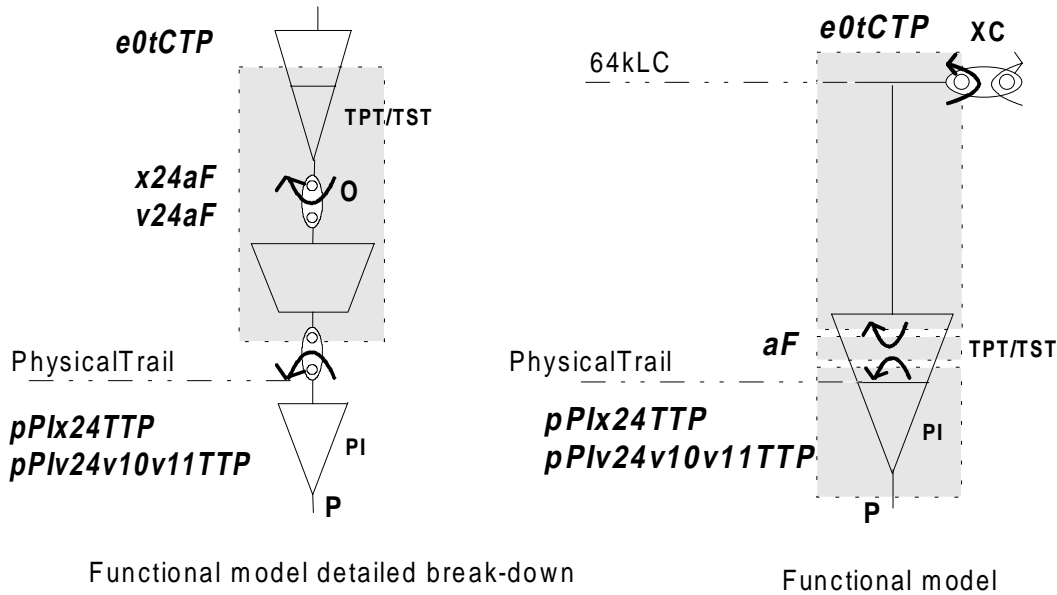

- O: Local loop-back according to X.150 loop 3c (X24)  
 Remote loop-back according to X.150 loop 2b (X24) or V.54 loop 2 (V24)
- XC: Local loopback according to X.150 loop 3b (X24) or V.54 loop 3 (V24)  
 Remote loopback according to X.150 loop 4b (X24) or V.54 loop 4(V24)

In the above diagram:

- X24 refers to CCITT Recommendation X.24 [20];
- V24 refers to ITU-T Recommendation V.24 [17];
- V54 refers to CCITT Recommendation V.54 [19];
- X150 refers to CCITT Recommendation X.150 [21].

**Figure 33: Modelling of the CCITT Recommendation X.150 [21] and CCITT Recommendation V.54 [19] loop-backs**

**C) Loop-backs of analogue tributary interfaces**

**Modelling of the test access and loop-backs in 2w/4w Voice Frequency (VF) tributary interfaces**

Connection points O and N are for voice band loops back to the 2M line. Depending on the type of interface the loop can be made either at reference point N or O. In addition a digital 64 kbit/s loop can be made for the voice signal at connection point XC.

A connection point TA has been added to the 2-wire/4-wire interface for access to an external (internal) test bus.

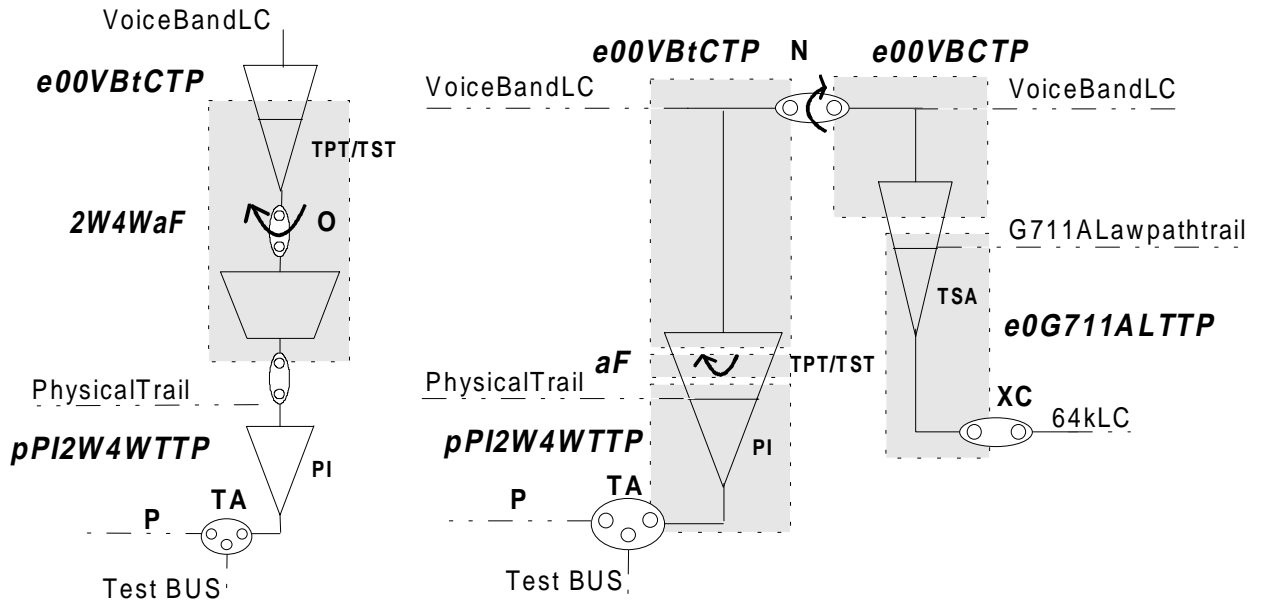

Functional model detailed break-down

Functional model

- N: Analog loop-back (2 - and 4 - wire application)
- O: Analog loop-back (4-wire application)
  
- XC: Digital 64 kbit/s loop-back
  
- TA: Test Access
  - a) for testing of the interface
  - b) for testing of the 2-w/4w physical line
  - c) for monitoring the physical connection

**Figure 34: Modelling of the test access and loop-backs of a 2/4 wire access for VF tributary interface**

Figure 35 shows a proposal for a detailed modelling of the CAS signalling. The speech path and the signalling are handled symmetrically. The signalling is divided into objects keeping in mind a future transition to common-channel signalling. DC signalling conversion to logical form (ON/OFF Hook, Ring, Polarity reversal etc.) is done in 2W4WDCaF. The CAS coding is done at the CAS Trail Termination point (TTP). A flexibility point has been added in-between.

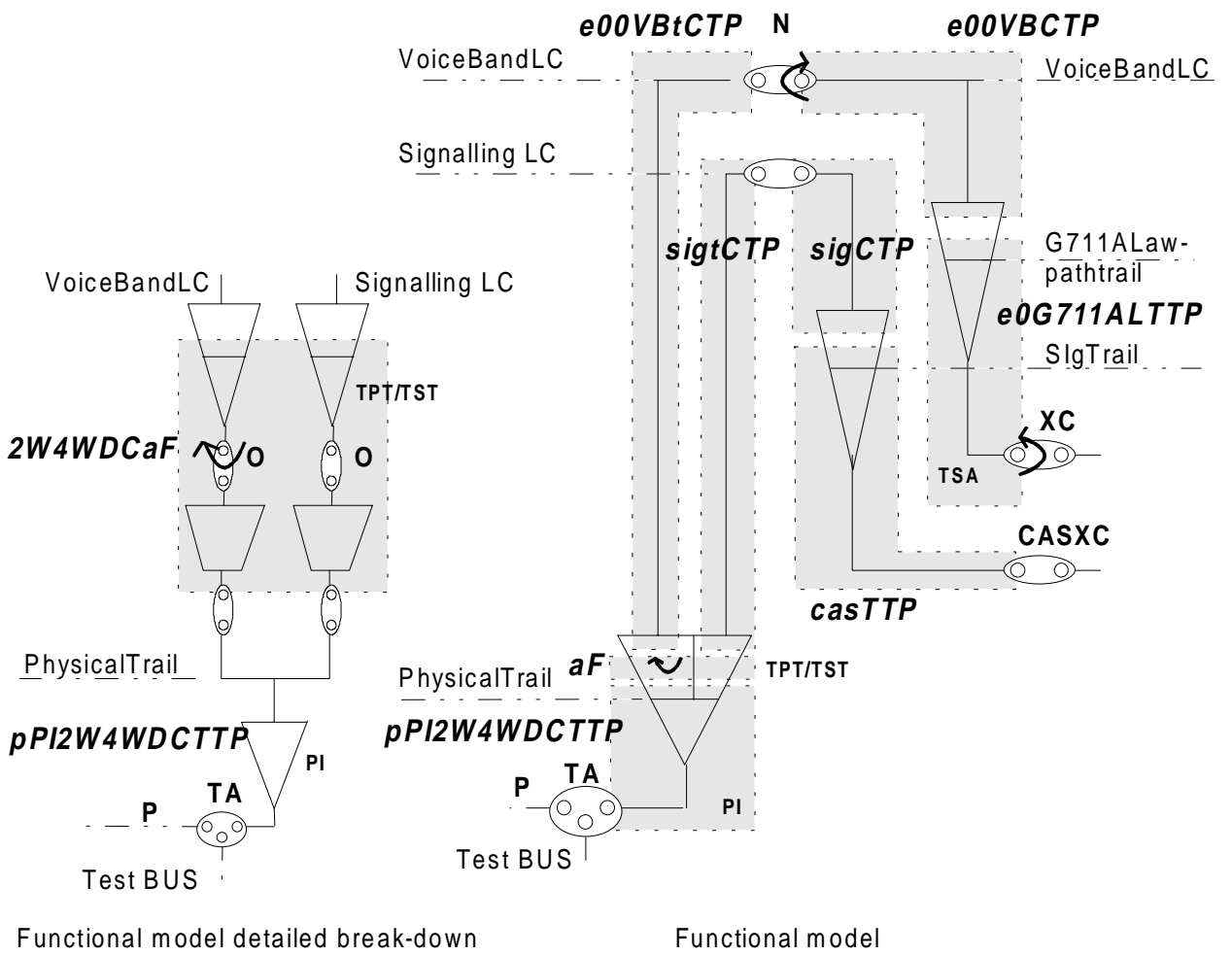

- N: Analog loop-back (2 and 4 -wire application)
- O: Analog loop-back (4-wire application)
  
- XC: Digital 64 kbit/s loop-back
  
- TA: Test Access
  - a) for testing of the interface
  - b) for testing of the 2-w/4w physical line
  - c) for monitoring the physical connection

**Figure 35: Modelling of the test access and loop-backs of a 2/4 wire access for VF tributary interface with signalling**

Loops at reference points O and N only include optional signalling. In case of loop-back the signalling state towards the analogue interface shall be configurable (depending on the signalling system: e.g. corresponding IDLE, BLOCKING states).

Figure 36 shows an updated model for wide band tributary interface. An analogue equipment loop-back can be made at reference point O. Logical loop-backs can be made according to CCITT Recommendation G.722 [4]. A connection point is added for test access to the analogue 4-wire interface (optional feature).

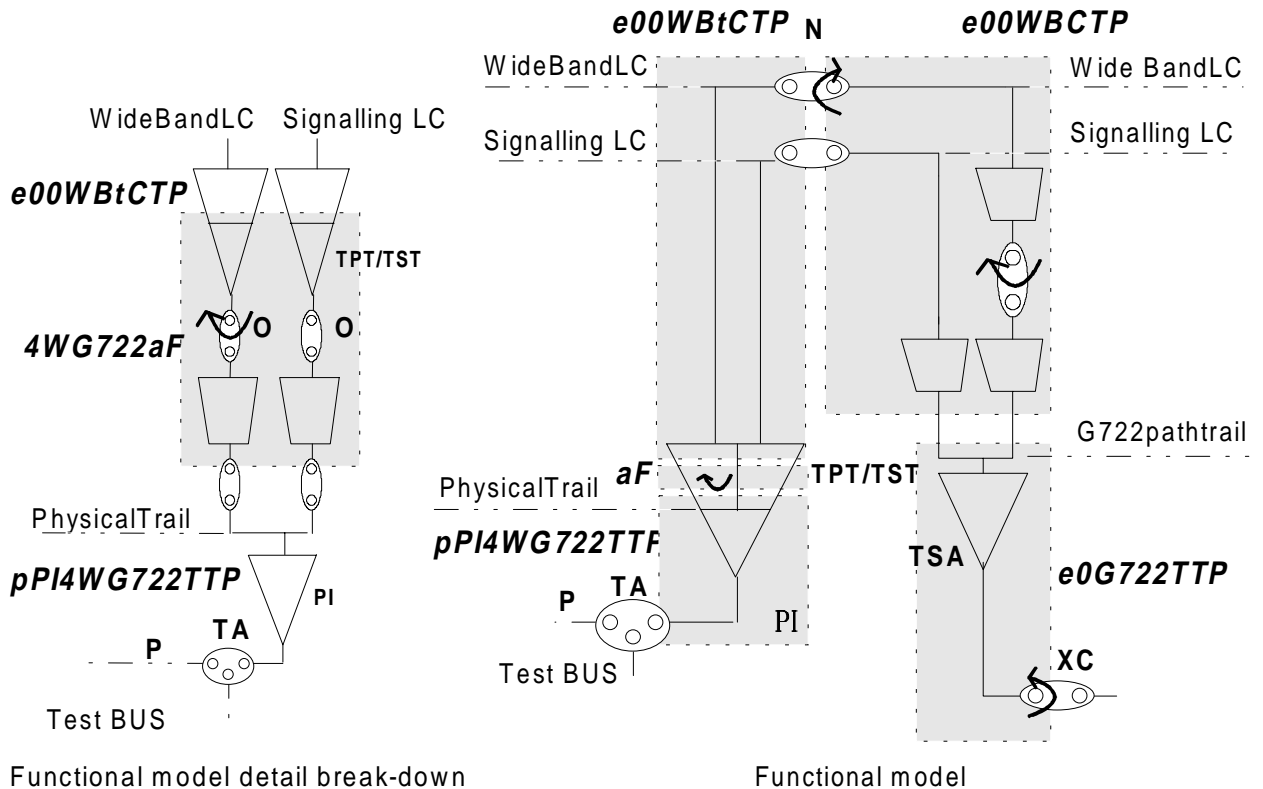

O (N): Analog loop-back (4-wire)

TSA: Logical 14 bits/16 kHz (uncoded) loop-back according to subclause 9b in CCITT Recommendation G.722 [4]

XC: Logical 64 kbit/s (SB-ADPCM coded) loop-back according to subclause 9a in CCITT Recommendation G.722 [4]

TA: Test Access  
 a) for testing of the 4w interface  
 b) for testing of the 4w physical line

**Figure 36: Modelling of the test access and loop-backs of a 4w-wire wide band access**

**D) Modelling of the test access of the 2 Mbit/s aggregate interface**

The outgoing 2 Mbit/s link connection can be monitored without breaking the connection. If the 2 Mbit/s test point is connected to an incoming 2 Mbit/s link connection, the main 2 Mbit/s link will be broken.

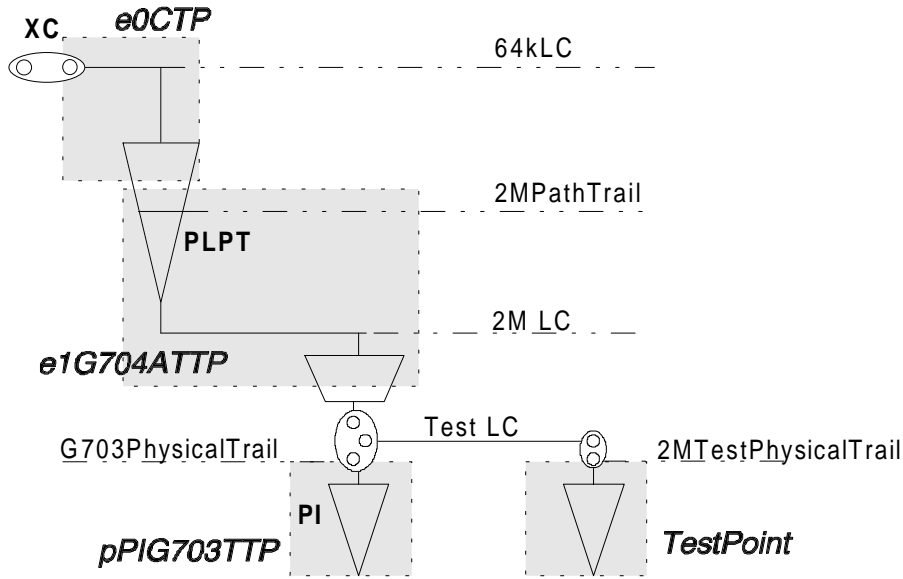

**Figure 37: Representation of the test access of a 2 Mbit/s aggregate interface**

**7.3.1.1.9 Management functions**

Figures 38 to 43 present the management functions of the FM.

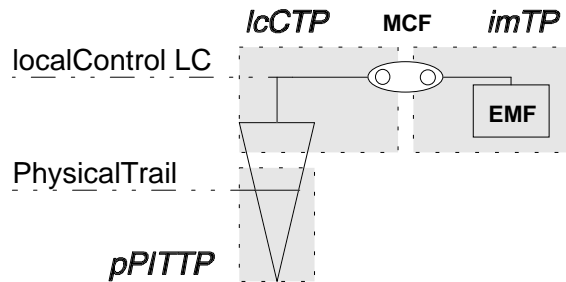

**Figure 38: Local management (LC interface)**

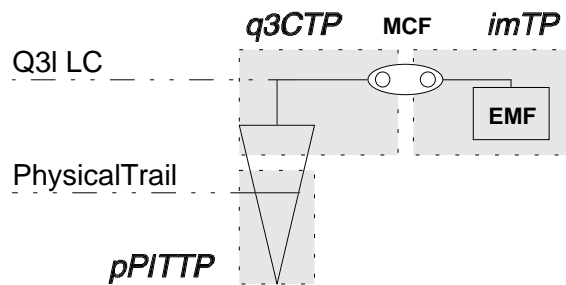

**Figure 39: Management through Q3 interface**

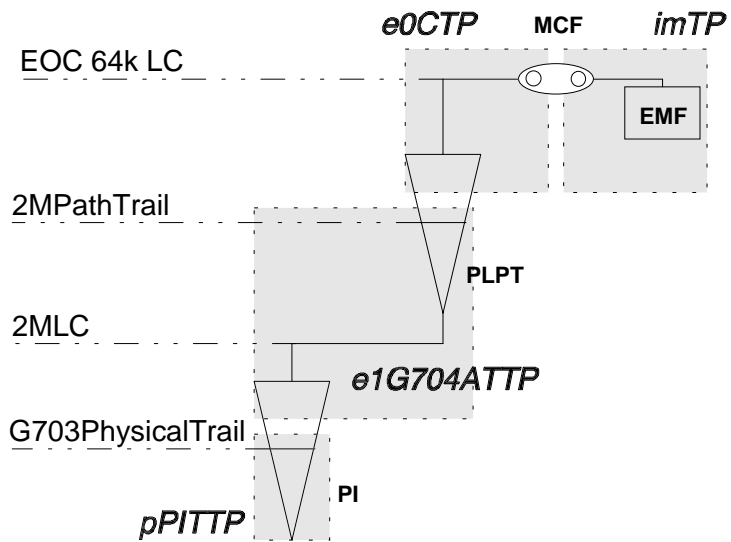

Figure 40: Management through 64 kbit/s EOC

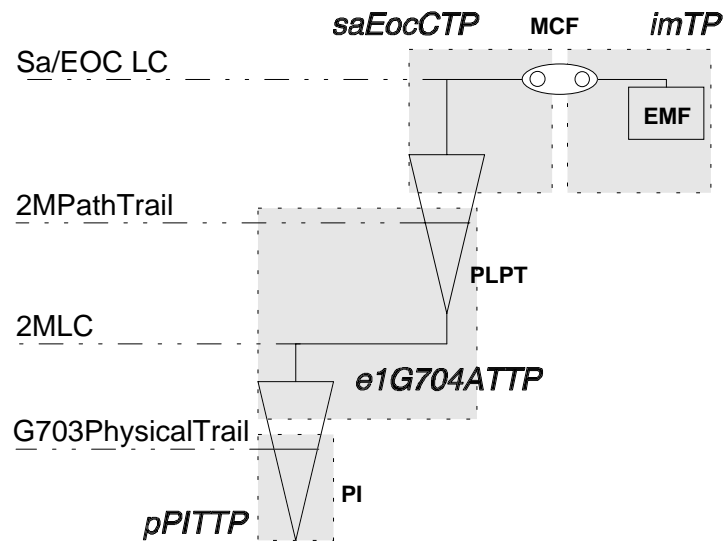

Figure 41: Management through aggregate Sa bit(s) EOC

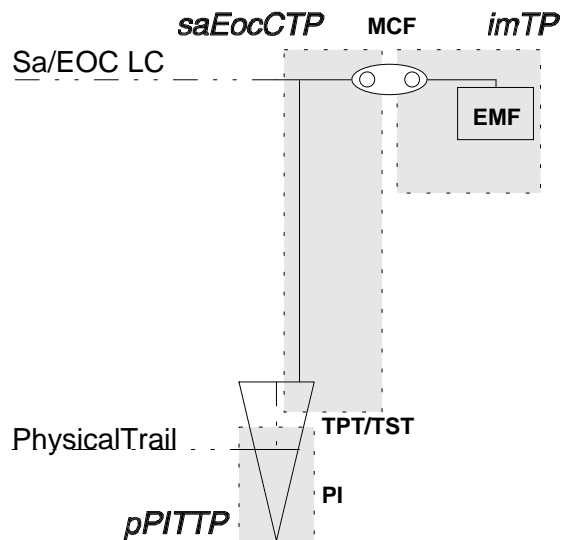

Figure 42: Management through tributary Sa bit(s) EOC

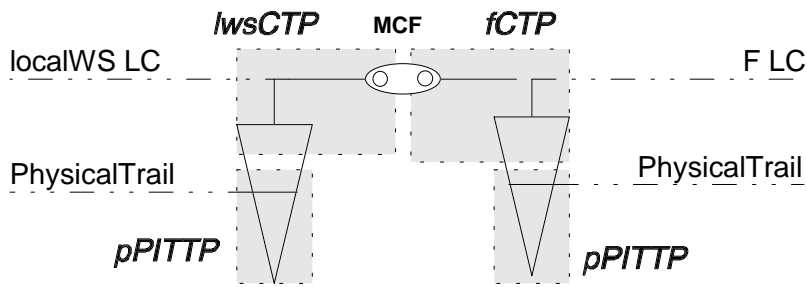

Figure 43: Management relay through F interface

### 7.3.1.2 Object classes

Object classes will be divided into different fragments:

Managed Element fragment:

- fm;
- fmEquipement;
- fmSoftware.

Aggregate fragment:

- pPI1G703TTP;
- e1G704ATTP;
- e0CTP;
- e1CTP;
- casCTP;
- ts16ATTP;
- e0G711ALTTP;
- e0G722TTP;
- e00VBCTP;
- e00WBCTP;
- saEocCTP;
- sigCTP;
- casTTP.

Tributary fragmnet:

- pPI0G703TTP;
- pPIx24TTP;
- x24aF;
- pPIv24v10v11TTP;
- v24aF;
- pPI2W4WTTP;
- pPI2W4WDCTTP;
- 2W4WaF;
- 2W4WDCaF;
- pPI4WG722TTP;
- 4WG722aF;
- e0tCTP;
- eNx0CTP;
- e00VBtCTP;
- e00WBtCTP;
- castCTP;
- saEoctCTP;
- sigtCTP.



Cross-Connection fragment:

- fmFabric (three instances of fabric may exist in the FM: for 64 kbit/s + CAS, for management cross-connections, and for unstructured CCITT Recommendation G.703 [1] 2 048 kbit/s transfer);
- e0gtp;
- casgtp;
- e0CrossConnection;
- casCrossConnection;
- e1CrossConnection;
- mngtCrossConnection.

Synchronization fragment:

- fmTimingGenerator;
- pPI1G703ITSTTP;
- pPI1G703OTSTTP;
- tSProtectionUnit;
- tSProtectionGroup.

Power feeding fragment:

- fmPowerFeeding.

Management fragment:

- lcCTP;
- q3CTP;
- mCTP;
- imTP.

Protection fragment:

- protectedTTP;
- unprotectedCTP;
- ISProtectionUnit;
- ISProtectionGroup;
- IPProtectionUnit;
- IPProtectionGroup.

### 7.3.1.3 Entities-relationships diagrams

Figures 44 to 53 give an overview of the entity relationship for the managed objects of the FM for the configuration purpose. Cardinality is not expressed in these diagrams.

In the following diagrams:

- "c" means "contains";
- "cc" means "crossconnects";
- "cp" means "is connected by connectivity pointers";
- "a" means "is associated with".

Convention applied in the following diagrams: Defined objects are in white boxes. Objects already defined but used for defining other objects are in grey boxes.

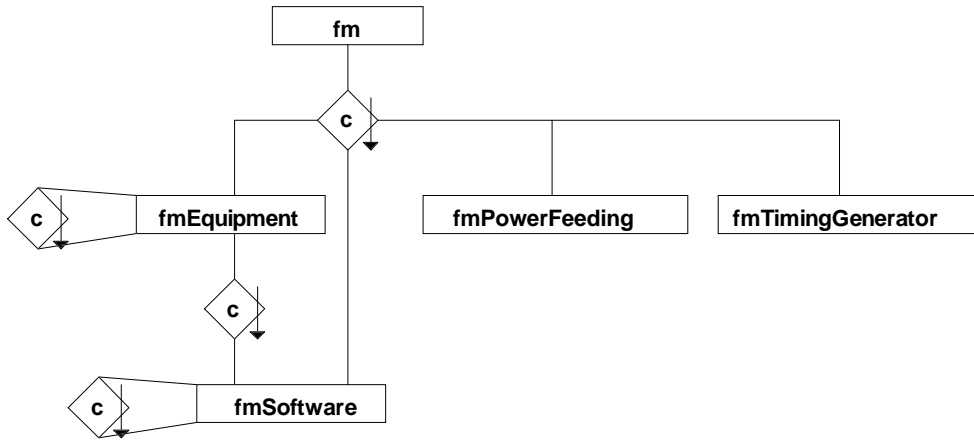

Figure 44: Entity relationship diagram. FM managed element

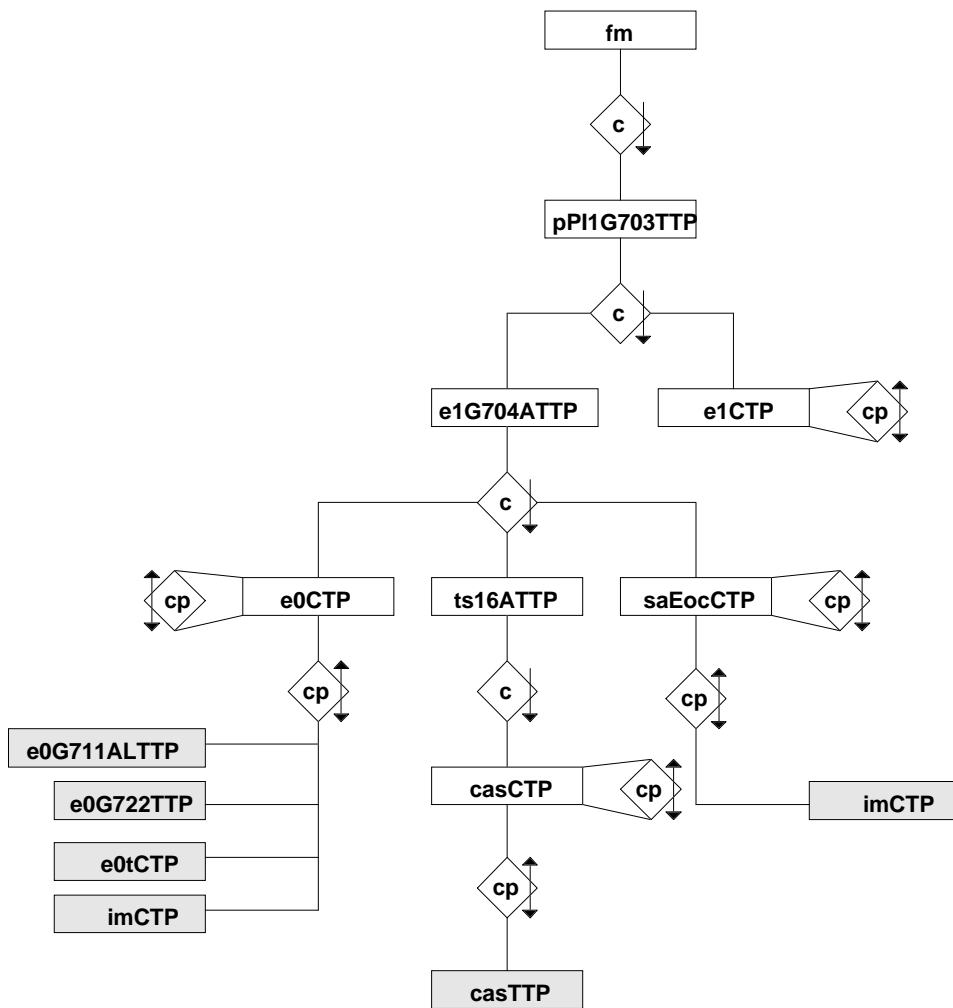

Figure 45: Entity relationship diagram. Aggregate entities -1

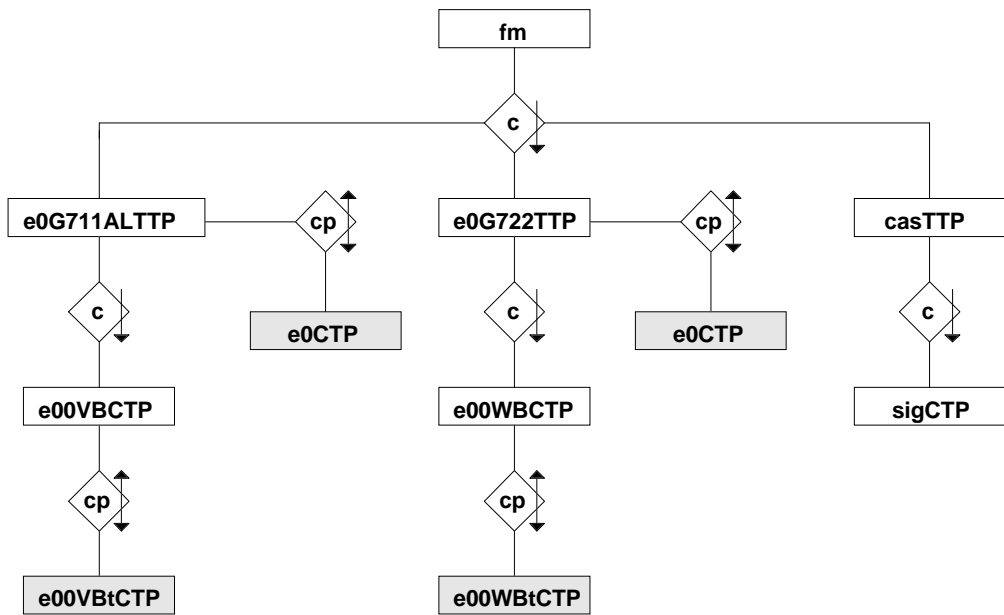

Figure 46: Entity relationship diagram. Aggregate entities -2

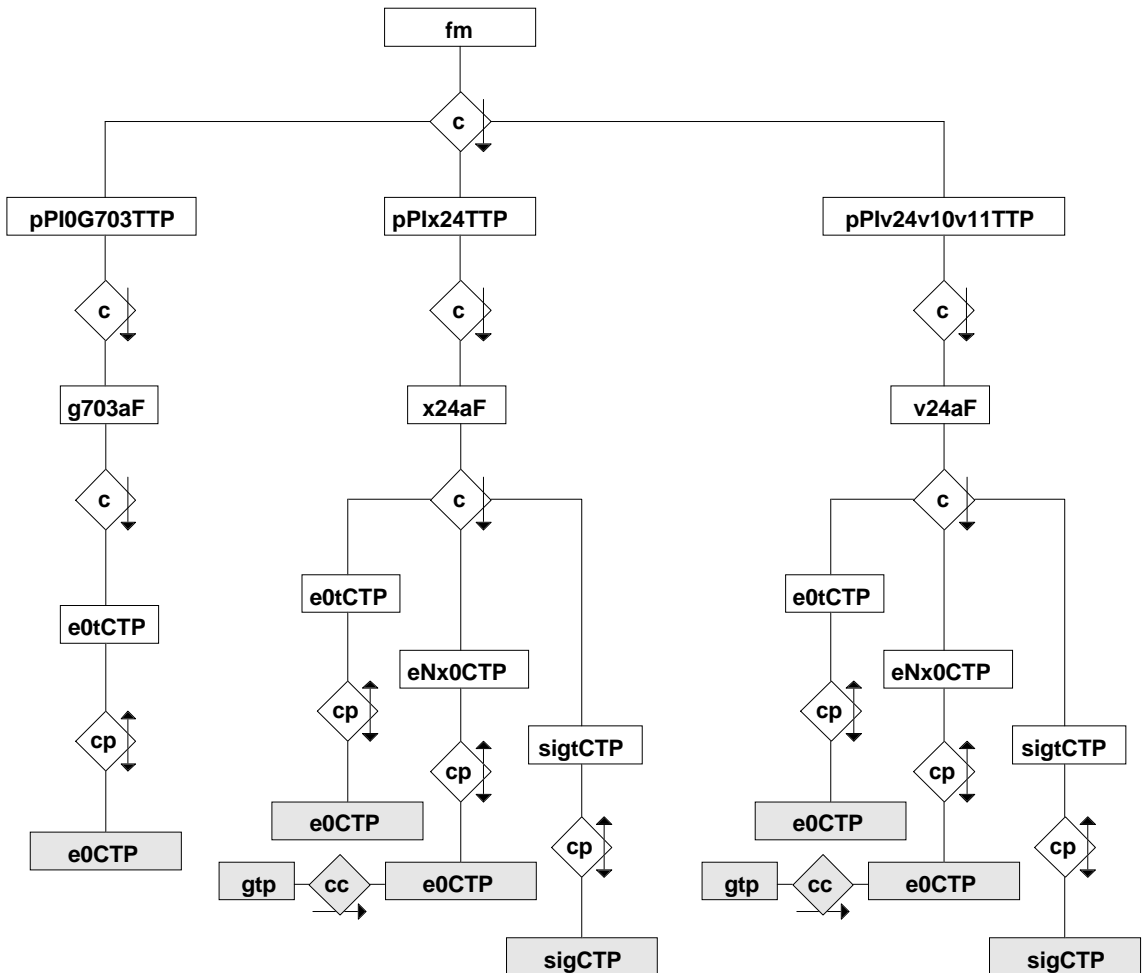

Figure 47: Entity relationship diagram. Tributary entities -1

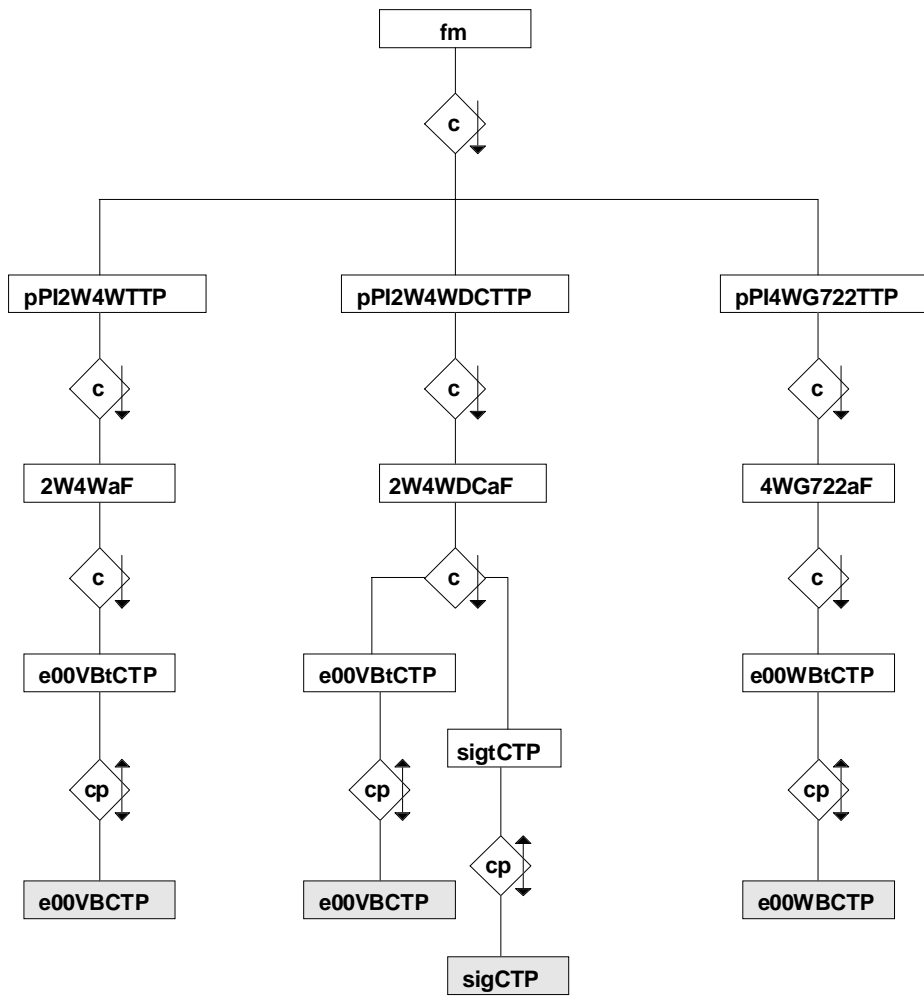

Figure 48: Entity relationship diagram. Tributary entities -2

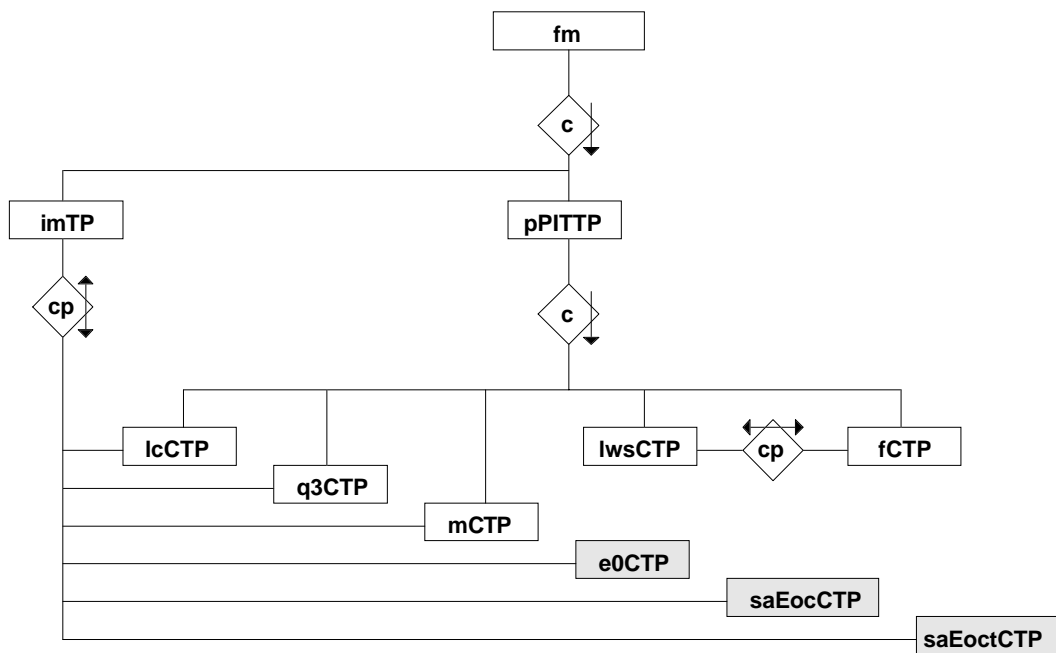

Figure 49: Entity relationship diagram. Management entities

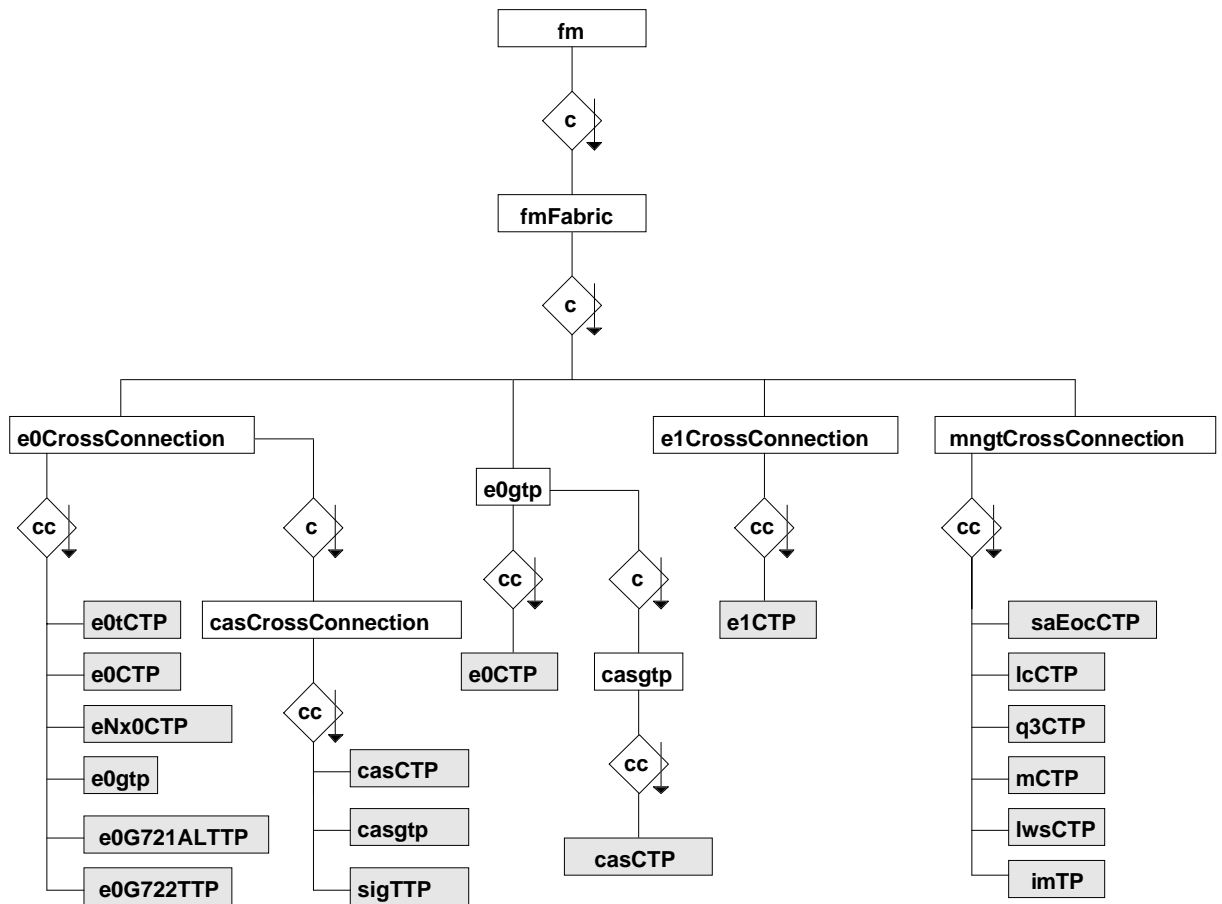

Figure 50: Entity relationship diagram. Cross-connection aspects

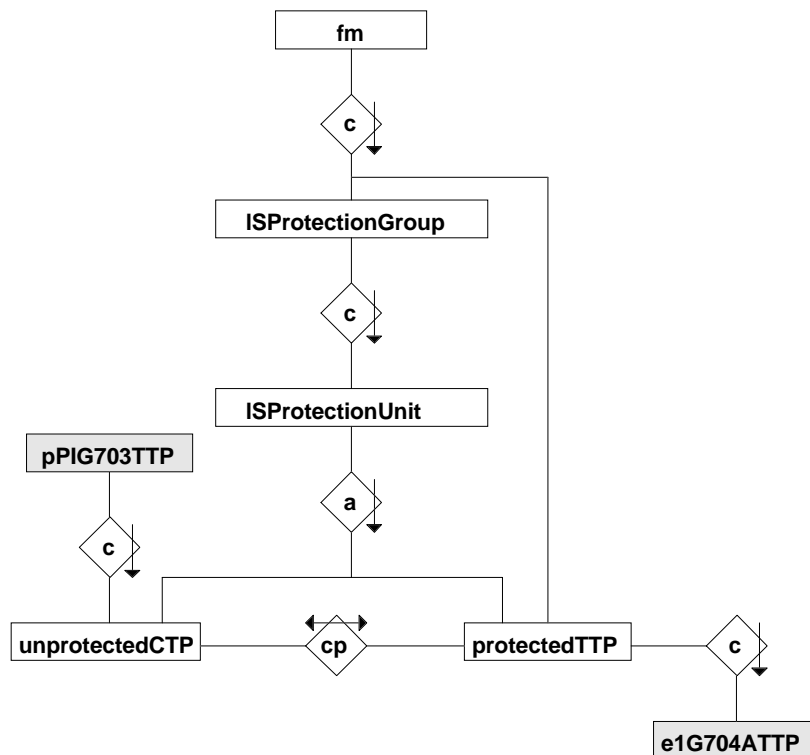

Figure 51: Entity relationship diagram. Lower order section protection

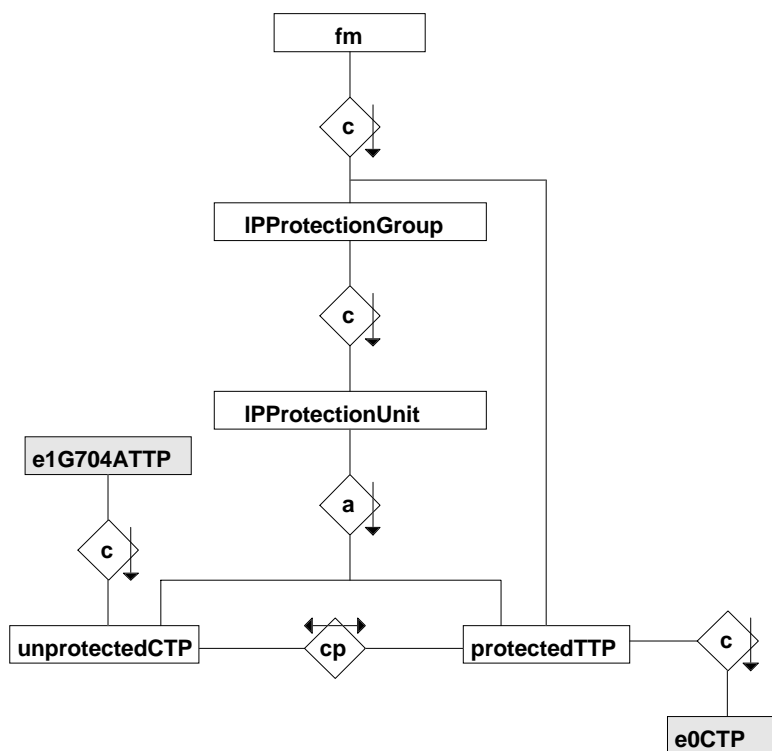

Figure 52: Entity relationship diagram. Lower order path protection

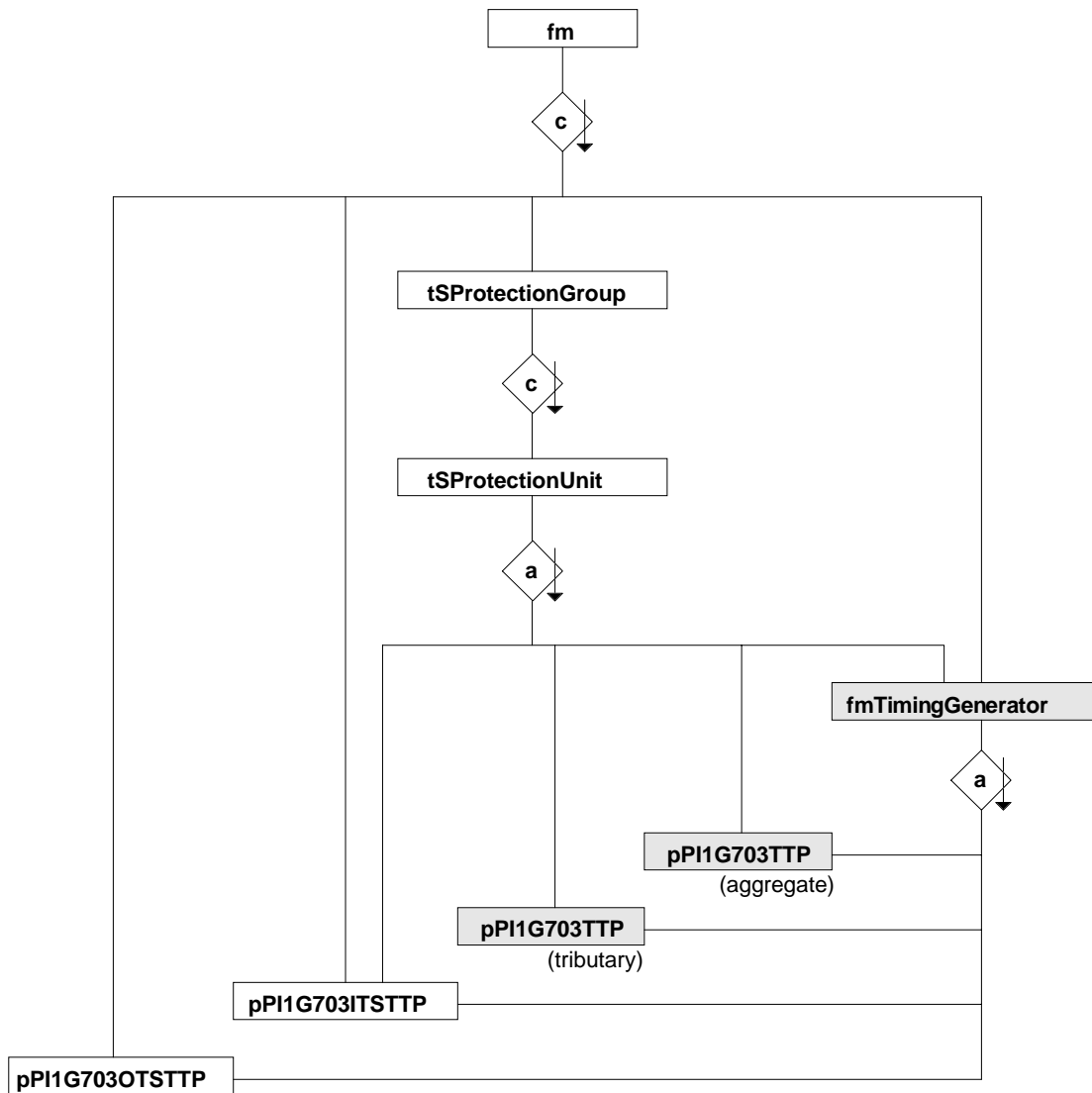

Figure 53: Entity relationship diagram. Synchronization

### 7.3.2 Description of the fragments

This description is not an information model (scope of clause 5) but has to be considered as a specification for writing this information model. Each characteristic of the Managed Object Classes (MOCs) of the final information model is described below in textual form.

Each MOC, e.g. *pPI1G703TTP*, in the final information model, contains attributes on which some management operations shall be performed. Some of these MOCs are also able to send notifications, e.g. alarm notifications.

This description shows the global behaviour of each MOC and describes the behaviour of their main attributes together with their notifications to be sent, if any, to an Operations System (OS) and operations to be performed by an OS.

The information model and this description, distinguish between a logical and a physical part of the FM managed element. The logical part is supported by the physical part which is more subject to proprietary implementation. CCITT Recommendation M.3100 [15] uses the equipment object class to represent the physical components of the managed element. An instance of this object class is present in a single geographical location. The physical components of the FM are represented by the *fmEquipment* MOC.

NOTE 1: The operations and notifications will be described according to the Common Management Information Service (CMIS) way as stated in CCITT Recommendation X.710 [22]. The [attr][[attr] etc.] syntax means that with the operations, some parameters (i.e. the attributes) of the entity can be given. The list of the attributes for each object below is intended as a reference list.

NOTE 2: It may be interesting to include the automatic creation/deletion of MOC in the description. Depending on the make-up and mode of operation of the FM, it may be possible to instantiate objects when the supporting or containing objects are instantiated.

NOTE 3: In this description names of MOC are written in italic.

NOTE 4: Even though connectivity pointers attributes are of interest for the information model, they are only detailed in this description in case of special use. Each MOC of the tributary fragment, aggregate fragment and management fragment will have connectivity pointers in the final information model. These connectivity pointers attributes are fully described in CCITT Recommendation M.3100 [15].

### 7.3.2.1 Managed element fragment

This edition does not include this fragment.

### 7.3.2.2 Aggregate fragment

#### 7.3.2.2.1 pPI1G703TTP (PI functional block)

#### Behaviour

This object class corresponds to the Physical Interface (PI) functional block of the functional diagram shown in figure 1 of ETS 300 461-1 [31] (part 1 of this ETS). It represents the point where the conversion between the line signal and the internal logic level plus timing is performed. This 2 048 kbit/s ITU-T Recommendation G.703 [1] physical Trail Termination Point (TTP) object class is a specialized *pPITTPBidirectional* object class defined in ETS 300 371 [29]. This managed object may be automatically instantiated when the supporting managed object (hardware block) is instantiated, depending on the make-up and mode of operation of the FM.

#### Attributes

- pPITTPId: Logical identification of the TTP. This identification shall be unique for a FM;
- supportedByObjectList: The value of the supportedByObjectList attribute points to the *fmEquipment* (hardware block) and *fmSoftware* objects which implement the TP;
- alarmSeverityAssignmentProfilePointer: The value of this attribute points to the *alarmSeverityAssignmentProfile* object which identifies the alarm severity assignment profile related to this TP. If this attribute is not present, the attribute *alarmSeverityAssignmentProfilePointer* of the containing object is used;
- states of the access port (ITU-T Recommendation X.731 [24]):
  - administrativeState (locked, unlocked): When the value is locked, the functions of the TP are administratively disabled, i.e. the TP does not process the signal nor detect failure of the signal. The administrativeState has no effect on the operationalState;
  - operationalState (enabled, disabled): The operational state is disabled if a LOS is detected or if one of the objects pointed to by the attribute supportedByObjectList is in the operationalState disabled;
  - alarmStatus: When an alarm is present on the TP, the value of this attribute indicates the severity of this alarm.



- impedance (75, 120): This attribute indicates the current impedance 75 W coaxial pair option, or a 120 W symmetrical pair option and, if provided, permits to select this impedance;
- testStatus (noTest, accessInputMonitoring, accessOutputMonitoring, accessTest, equipmentTest): The value of this optional attribute indicates the type of the current connection between the termination point and a test point of the FM. This attribute is updated automatically after the test point has received a setTestPoint action;
- bipolarViolationCounting (Yes, No): This optional attribute permits activation of bipolar violation counting.

### Operations

- create [pPITTPId, supportedByObjectList, alarmSeverityAssignmentProfilePointer, administrativeState, operationalState, alarmStatus, impedance, testStatus, bipolarViolationCounting] (no need if automatic creation );
- delete (no need if automatic deletion );
- modify [administrativeState, alarmSeverityAssignmentProfilePointer, impedance (if provided), bipolarViolationCounting];
- get [pPITTPId, supportedByObjectList, alarmSeverityAssignmentProfilePointer, administrativeState, operationalState, alarmStatus, impedance, testStatus, bipolarViolationCounting].

### Notifications

- alarm notification (refers to CCITT Recommendation G.703 [1] alarms): A communicationsAlarm notification shall be issued if a LOS is detected. The probableCause parameter of the notification shall indicate LOS;
- state change notification: A stateChange notification may be issued in case of operationalState change or alarmStatus change;
- attribute value change notification: An attributeValueChange notification is issued if any of the following attributes changes in value: alarmSeverityAssignmentProfilePointer, testStatus.

#### 7.3.2.2.2 e1G704ATTP (PLPT functional block)

### Behaviour

This object refers to the Plesiochronous Lower Order Path Termination (PLPT) functional block of the functional diagram shown in figure 1 of ETS 300 461-1 [31] (part 1 of this ETS). This 2 048 kbit/s CCITT Recommendation G.704 [2] AIS trail termination point object class is a specialized *e1ATTPBidirectional* object class defined in ETS 300 371 [29]. This object therefore, includes the functions of a respective Connection Termination Point (CTP), e.g. AIS monitoring, which is not instantiated because no connectivity is provided at this level.

### Attributes

- ePDHTTPId: Logical identification of the termination point;
- alarmSeverityAssignmentProfilePointer: The value of this attribute points to the *alarmSeverityAssignmentProfile* object which identifies the alarm severity assignment profile related to this TP. If this attribute is not present, the alarmSeverityAssignmentProfilePointer of the containing object is used;
- mappingRules (adjacent, free): The value of this attribute defines the distribution rule of the time slots in the CCITT Recommendation G.704 [2] frame;

- bit4Usage (zero, one, eoc, signalling): The value of this attribute reflects the use of the Sa bit 4 of time slot 0 without frame alignment. The eoc value indicates that a *saEocCTP* is instantiated. The signalling value indicates that the Sa bit provides an additional far end defect or failure information;
- bit5Usage (zero, one, eoc, signalling): The value of this attribute reflects the use of the Sa bit 5 of time slot 0 without frame alignment. The eoc value indicates that a *saEocCtp* is instantiated. The signalling value indicates that the Sa bit provides an additional far end defect or failure information;
- bit6Usage (zero, one, eoc, signalling): The value of this attribute reflects the use of the Sa bit 6 of time slot 0 without frame alignment. The eoc value indicates that a *saEocCtp* is instantiated. The signalling value indicates that the Sa bit provides an additional far end defect or failure information;
- bit7Usage (zero, one, eoc, signalling): The value of this attribute reflects the use of the Sa bit 7 of time slot 0 without frame alignment. The eoc value indicates that a *saEocCtp* is instantiated. The signalling value indicates that the Sa bit provides an additional far end defect or failure information;
- bit8Usage (zero, one, eoc, signalling): The value of this attribute reflects the use of the Sa bit 8 of time slot 0 without frame alignment. The eoc value indicates that a *saEocCtp* is instantiated. The signalling value indicates that the Sa bit provides an additional far end defect or failure information;
- tS16Mode (64kbit/sData/CCS, CAS/CAC): This attribute indicates the use of time slot 16. The 64kbit/sData/CCS value indicates that a *eOCTP* is instantiated. The CAS/CAC value indicates that a *tS16ATTP* is instantiated;
- states of the port (ITU-T Recommendation X.731 [24]):
  - administrativeState (locked, unlocked): When the value is locked, the functions of the TP are administratively disabled, i.e. the TP does not process the CCITT Recommendation G.704 [2] frame anymore which implies no more monitoring of alarms, nor generation of the frame. The administrativeState has no effect on the operationalState;
  - operationalState (enabled, disabled): The operational state is disabled if the TP is unable to process the signal (e.g. the containing object is in the operationalState disabled) or if one of the following defaults is detected:
    - Alarm Indication Signal (AIS);
    - Loss Of Frame (LOF).
  - alarmStatus: The value of this attribute indicates the highest severity of the current alarms on the TP.
- internalFilteringProfilePointer: The value of this attribute points to the *internalFilteringProfile* object which identifies the internal filtering profile related to this TP. If this attribute is not present, the internalFilteringProfilePointer of the containing object is used.

## Operations

- create [ePDHTTPId, alarmSeverityAssignmentProfilePointer, mappingRules, bit4Usage, bit5Usage, bit6Usage, bit7Usage, bit8Usage, tS16Mode, administrativeState, operationalState, alarmStatus, internalFilteringProfilePointer];
- delete;
- modify [mappingRules, bit4Usage, bit5Usage, bit6Usage, bit7Usage, bit8Usage, tS16Mode, administrativeState, internalFilteringProfilePointer];
- get [ePDHTTPId, alarmSeverityAssignmentProfilePointer, mappingRules, bit4Usage, bit5Usage, bit6Usage, bit7Usage, bit8Usage, tS16Mode, administrativeState, operationalState, alarmStatus, internalFilteringProfilePointer].

## Notifications

- alarm notification: (refers to CCITT Recommendation G.704 [2] alarms). A communicationsAlarm notification shall be issued if one of the following defects or failures is detected:
  - Loss Of Frame (LOF);
  - Excessive Bit Error Ratio (EBER) if specified;
  - RAI from remote end (RAI);
  - Alarm Indication Signal (AIS);
  - Remote AIS (RAIS) if provided;
  - Remote Loss of Synchronization Reference (RLSR) if provided.

The probableCause parameter of the notification shall indicate respectively LOF, EBER, RAI, AIS, RAIS, FS, CRC4BE, RCRC4BE, RLSR.

- state change notification: A stateChange notification may be issued in case of operationalState change or alarmStatus change;
- attribute value change notification: An attributeValueChange notification is issued if the following attribute changes in value: alarmSeverityAssignmentProfilePointer.

### 7.3.2.2.3 e1CTP (connection termination point at 2 048 kbit/s)

#### Behaviour

An instance of this object class originates and terminates a 2 048 kbit/s link connection. It represents the 2 048 kbit/s CTP which is used for transparent cross-connection of 2 048 kbit/s signals (signal at reference points O and G in the functional diagram shown in figure 1 of ETS 300 461-1 [31] (part 1 of this ETS)). The detection of AIS is not required for an unstructured interface. This 2 048 kbit/s CTP object class is a specialized *e1CTPBidirectional* object class defined in the ETS 300 371 [29].

#### Attributes

- ePDHCTPId: Logical identification of the termination point;
- alarmSeverityAssignmentProfilePointer: The value of this attribute points to the *alarmSeverityAssignmentProfile* object which identifies the alarm severity assignment profile related to this TP. If this attribute is not present, the alarmSeverityAssignmentProfilePointer of the containing object is used;
- crossConnectionObjectPointer: The value of this attribute points to an *e1CrossConnection* object. When not cross-connected, the value of this attribute points to the right instance of *fmFabric*;
- characteristicInformation (list of values to be defined): The value of this attribute is used to verify the connectability of the connection points;
- states of the port, (ITU-T Recommendation X.731 [24]):
  - administrativeState (locked, unlocked): When the administrative state is locked, the CTP cannot be cross-connected;
  - operationalState (enabled, disabled): The operational state is disabled if the TP is unable to process the signal (e.g. the containing object is in the operationalState disabled) or if an AIS (If relevant) is detected;
  - alarmStatus: The value of this attribute indicates the severity of the current alarm on the TP.
- currentLoopState (NULL, loopType): The value of this attribute indicates if a loop is or is not present on the interface. In the case where a loop is present, the loopType value indicates the orientation of the loop (localEquipmentSide, localLineSide). A change in the value of the currentLoopState attribute shall cause an attributeValueChange notification;
- loopSet (localEquipmentSide, localLineSide): This attribute permits selection of a type of loop.

## Operations

- create [ePDHCTPId, alarmSeverityAssignmentProfilePointer, crossConnectionObjectPointer, characteristicInformation, administrativeState, operationalState, alarmStatus, currentLoopState, loopSet];
- delete;
- modify [alarmSeverityAssignmentProfilePointer, administrativeState, loopSet];
- get [ePDHCTPId, alarmSeverityAssignmentProfilePointer, crossConnectionObjectPointer, characteristicInformation, administrativeState, operationalState, alarmStatus, currentLoopState, loopSet].

## Notifications

- alarm notification (refers to CCITT Recommendation G.704 [2] alarms): A communicationsAlarm notification shall be issued if an AIS is detected (If relevant). The probableCause parameter of the notification shall indicate AIS;
- state change notification: A stateChange Notification may be issued in case of operationalState change;
- attribute value change notification: An attributeValueChange notification is issued if any of the following attributes changes in value: alarmSeverityAssignmentProfilePointer, alarmStatus, currentLoopState.

### 7.3.2.2.4 ts16ATTP (PLPT functional block)

#### Behaviour

This object refers to the PLPT functional block of the functional diagram shown in figure 1 of ETS 300 461-1 [31] (part 1 of this ETS) and is created when time slot 16 is used for channel associated signalling. This object includes the functions of a respective CTP (e.g. AIS monitoring) which is not instantiated because no connectivity is provided at this level. This object is a specialized *trailTerminationPoint* object class defined in CCITT Recommendation M.3100 [15].

#### Attributes

- ttpId: Logical identification of the TP.
- alarmSeverityAssignmentProfilePointer: The value of this attribute points to the *alarmSeverityAssignmentProfile* object which identifies the alarm severity assignment profile related to this TP. If this attribute is not present, the attribute alarmSeverityAssignmentProfilePointer of the containing object (*e1G704ATTP*) is used;
- states of the port (ITU-T recommendation X.731 [24]):
  - operationalState (enabled, disabled): The operational state is disabled if the TP is unable to process the signal (e.g. the containing object is in the operationalState disabled) or if one of the following defaults is detected:
    - Alarm Indication Signal (AIS) (see note 1);
    - Loss of MultiFrame Alignment (LMFA).
  - alarmStatus: The value of this attribute indicates the highest severity of the current alarms on the TP.

## Operations

- create [ttpld, alarmSeverityAssignmentProfilePointer, administrativeState, operationalState, alarmStatus];
- delete;
- modify [alarmSeverityAssignmentProfilePointer, administrativeState];
- get [ttpld, alarmSeverityAssignmentProfilePointer, administrativeState, operationalState, alarmStatus].

## Notifications

- alarm notification (refers to ITU-T recommendation G.704 [2] alarms): A communicationsAlarm notification shall be issued if one of the following defects or failures is detected:
  - Alarm Indication Signal (AIS) (see note 1);
  - Loss of MultiFrame Alignment (LMFA);
  - Remote Alarm Indication (RAI) (see note 2).

The probableCause parameter of the notification shall indicate respectively AIS, LMFA, RAI.

- state change notification: A stateChange notification may be issued in case of operationalState change or alarmStatus change;
- attribute value change notification: An attributeValueChange notification is issued if the following attribute changes in value: alarmSeverityAssignmentProfilePointer.

NOTE 1: Noted AIS TS16 in table 1.

NOTE 2: Noted RMAI in table 1.

### 7.3.2.2.5 e0CTP (Connection termination point at 64 kbit/s)

#### Behaviour

An instance of this object class originates and terminates a 64 kbit/s link connection. It represents the 64 kbit/s CTP which is used for cross-connection of 64 kbit/s signals (signals at reference points J and optionally K and L in the functional diagram shown in figure 1 of ETS 300 461-1 [31] (part 1 of this ETS)).

This 64 kbit/s CTP object class is a specialized *e0CTPBidirectional* object class defined in ETS 300 371 [29]. This managed object may be automatically instantiated when the superior managed object (*e1G704ATTP*) is instantiated, depending on the make-up and mode of operation of the FM.

#### Attributes

- e0CTPId: The value of this attribute indicates the number of the time slot in the CCITT Recommendation G.704 [2] frame;
- crossConnectionObjectPointer: The value of this attribute points to an *e0CrossConnection* or a *e0gtp* object. When not cross-connected, the value of this attribute points to the correct instance of *fmFabric*;
- administrative State (locked, unlocked): When the administrative state is locked, the CTP cannot be cross-connected.

## Operations

- create [e0CTPId, crossConnectionObjectPointer, administrative State];
- delete;
- modify [administrative State];
- get [e0CTPId, crossConnectionObjectPointer, administrative State].

### 7.3.2.2.6 casCTP (CAS Connection Point)

#### Behaviour

An instance of this object class originates and terminates the channel associated signalling link connection which is associated to each 64 kbit/s link connection when time slot 16 is used on an CCITT Recommendation G.704 [2] trail. It is used for cross-connection of CAS signals (signals at reference point L of the functional diagram shown in figure 1 of ETS 300 461-1 [31] (part 1 of this ETS)).

The CAS CTP object class is a specialized *ConnectionTerminationPointBidirectional* defined in CCITT Recommendation M.3100 [15]. This managed object may be automatically instantiated when the superior managed object (*ts16ATTP*) is instantiated, depending on the make-up and mode of operation of the FM.

#### Attributes

- casCTPId: Logical identification of the connection point. The value of this attribute shall be equal to the number of the time slot in the CCITT Recommendation G.704 [2] frame of the 64 kbit/s associated CTP;
- crossConnectionObjectPointer: The value of this attribute points to a *casCrossConnection* or a *casgtp* object. When not cross-connected, the value of this attribute points to the correct instance of *fmFabric*;
- abcdBitIdlecode (1 to F): The value of this attribute indicates the idle code on abcd bits when not cross-connected. On aggregate side, this attribute takes the F value.

#### Operations

- create [casCTPId, crossConnectionObjectPointer, administrativeState, abcdBitIdlecode];
- delete;
- modify [administrativeState, abcdBitIdlecode];
- get [casCTPId, crossConnectionObjectPointer, administrativeState, abcdBitIdlecode].

### 7.3.2.2.7 saEocCTP (Sa bit EOC connection termination point)

#### Behaviour

An instance of this object class originates and terminates the EOC on one of the Sa bits of a CCITT Recommendation G.704 [2] trail. It is used for cross-connection of management signals (signals at the reference points U1 or U3 in the functional diagram shown in figure 1 of ETS 300 461-1 [31] (part 1 of this ETS)) for management purposes. The Sa bits Connection Termination Point objects class is a specialized *ConnectionTerminationPointBidirectional* defined in CCITT Recommendation M.3100 [15].

### Attributes

- saCTPId: Logical identification of the connection point. The value of this attribute corresponds to the number of the Sa bit used in TS0 of the CCITT Recommendation G.704 [2] frame;
- crossConnectionObjectPointer: The value of this attribute points to a *mngtCrossConnection* object. When not cross-connected, the value of this attribute points to the correct instance of *fmFabric*.

### Operations

- create [saCTPId, crossConnectionObjectPointer, administrativeState];
- delete;
- modify [administrativeState];
- get [saCTPId, crossConnectionObjectPointer, administrativeState].

#### 7.3.2.2.8 e0G711ALTTP (TSA functional block)

### Behaviour

This object refers to the TSA functional block of the functional diagram shown in figure 1 of ETS 300 461-1 [31] (part 1 of this ETS) for the coding of analogue signals with the A-law in accordance with CCITT Recommendation G.711 [3]. This 64 kbit/s CCITT Recommendation G.711 [3] A-Law TTP object class is derived from *ePDHTTPBidirectional* (ETS 300 371 [29]). This managed object may be automatically instantiated when the supporting managed object (hardware block) is instantiated, depending on the make-up and operational mode of the equipment.

### Attributes

- ePDHTTPId: Logical identification of the termination point. This identification shall be unique for a FM;
- supportedByObjectList: The value of the supportedByObjectList attribute points to the *fmEquipment* (hardware block) and *fmSoftware* objects which implement the TP;
- crossConnectionObjectPointer: The value of this attribute points to a *crossConnection* object. When not cross-connected, the value of this attribute points to the right instance of *fmFabric*.
- states of the port (ITU-T Recommendation X.731 [24]):
  - administrativeState (locked, unlocked): When the value is locked, the functions of the TP are administratively disabled, i.e. the TP administrativeState has no effect on the operationalState;
  - operationalState (enabled, disabled): The operational state is disabled if one of the objects pointed to by the attribute supportedByObjectList is in the operationalState disabled.

### Operations

- create [ePDHTTPId, supportedByObjectList, crossConnectionObjectPointer, administrativeState, operationalState]. No need if automatic creation;
- delete;
- modify [administrativeState];
- get [ePDHTTPId, supportedByObjectList, crossConnectionObjectPointer, administrativeState, operationalState].

## Notifications

- state change notification: A stateChange notification may be issued in case of operationalState change.

### 7.3.2.2.9 e0G722TTP (TSA functional block)

#### Behaviour

This object refers to the TSA functional block of the functional diagram shown in figure 1 of ETS 300 461-1 [31] (part 1 of this ETS) for the coding of analogue signals in accordance with CCITT Recommendation G.722 [4]. This 64 kbit/s CCITT Recommendation G.722 [4] TTP object class is derived from *ePDHTTPBidirectional* (ETS 300 371 [29]). This managed object may be automatically instantiated when the supporting managed object (hardware block) is instantiated, depending on the make-up and operational mode of the FM.

#### Attributes

- ePDHTTPIId: Logical identification of the termination point: This identification shall be unique for a FM;
- supportedByObjectList: The value of the supportedByObjectList attribute points to the *fmEquipment* (hardware block) and *fmSoftware* objects which implement the TP;
- crossConnectionObjectPointer: The value of this attribute points to a *crossConnection* object. When not cross-connected, the value of this attribute points to the right instance of *fmFabric*;
- states of the port (ITU-T Recommendation X.731 [24]):
  - administrativeState (locked, unlocked): when the value is locked, the functions of the TP are administratively disabled, i.e. the TP administrativeState has no effect on the operationalState;
  - operationalState (enabled, disabled): The operational state is disabled if one of the objects pointed to by the attribute supportedByObjectList is in the operationalState disabled;
- currentLoopState (NULL, loopType): The value of this attribute indicates if a logical loopback is present or not on the interface. In the case where a loop is present, the loopType value indicates the type of loop (9a or 9b) in accordance with figure 9a or 9b of CCITT Recommendation G.722 [4]. A change in the value of the currentLoopState attribute shall cause an attributeValueChange notification;
- loopSet (NULL, loopType): This attribute permits selection of a type of loop.

#### Operations

- create [ePDHTTPIId, supportedByObjectList, crossConnectionObjectPointer, administrativeState, operationalState, loopState] No need if automatic creation;
- delete;
- modify [administrativeState, loopState];
- get [ePDHTTPIId, supportedByObjectList, crossConnectionObjectPointer, administrativeState, operationalState, loopState].



## Notifications

- state change notification: A `stateChange` notification may be issued in case of `operationalState` change;
- attribute value change notification: An `attributeValueChange` notification is issued if the following attribute changes in value: `loopState`.

### 7.3.2.2.10 e00VBCTP (Voice band connection termination point)

#### Behaviour

An instance of this object class originates and terminates a voice band link connection. It represents the voice band connection termination point on a *e0G711ALTTP*. This voice band connection point object class is a specialized *ePDHCTPBidirectional* defined in ETS 300 371 [29]. This managed object may be automatically instantiated when the superior managed object (*e0G711ALTTP*) is instantiated, depending on the make-up and operational mode of the equipment.

#### Attributes

- `ePDHCTPId`: The value of this attribute indicates the position of the voice band channel in the CCITT Recommendation G.711 [3] A-Law frame;
- `supportedByObjectList`: The value of the `supportedByObjectList` attribute points to the *fmEquipment* (hardware block) and *fmSoftware* objects which implement the TP.

#### Operations

- create [`ePDHCTPId`, `supportedByObjectList`];
- delete;
- get [`ePDHCTPId`, `supportedByObjectList`].

### 7.3.2.2.11 e00WBCTP (Wide band connection termination point)

#### Behaviour

An instance of this object class originates and terminates a wide band link connection. It represents the wide band connection termination point on an *e0G722TTP*. This voice band connection point object class is a specialized *ePDHCTPBidirectional* defined in the ETS 300 371 [29]. This managed object may be automatically instantiated when the superior managed object (*e0G722TTP*) is instantiated, depending on the make-up and operational mode of the equipment.

#### Attributes

- `ePDHCTPId`: The value of this attribute indicates the position of the wide band channel in the CCITT Recommendation G.722 [4] frame;
- `supportedByObjectList`: The value of the `supportedByObjectList` attribute points to the *fmEquipment* (hardware block) and *fmSoftware* objects which implement the TP.

#### Operations

- create [`ePDHCTPId`, `supportedByObjectList`];
- delete;
- get [`ePDHCTPId`, `supportedByObjectList`].

### 7.3.2.3 Tributary fragment

#### 7.3.2.3.1 pPI0G703TTP (PI functional block)

##### Behaviour

This object class corresponds to the PI functional block located between reference points P and O of the functional diagram shown in figure 1 of ETS 300 461-1 [31] (part 1 of this ETS). It represents the point where the conversion between the line signal and the internal logic level plus timing is performed. At point O codirectional mode is assumed independently of timing mode at the physical interface. Octet timing at the physical interface (a type of signalling) is controlled from the adaptation function block. This 64 kbit/s CCITT Recommendation G.703 [1] physical TTP object class is derived from the *pPITTPBidirectional* object class defined in ETS 300 371 [29]. This managed object is automatically instantiated when the supporting managed object (transmission board) is instantiated.

##### Attributes

- pPITTPId: Logical identification of the TTP. This identification shall be unique for a FM;
- supportedByObjectList: The value of the supportedByObjectList attribute points to the *equipment* (transmission board) and *software* objects which implement the TP;
- alarmSeverityAssignmentProfilePointer: The value of this attribute points to the *alarmSeverityAssignmentProfile* object which identifies the alarm severity assignment profile related to this TP. If this attribute is not present, default severities are used;
- states of the access port (ITU-T Recommendation X.731 [24]):
  - administrativeState (locked, unlocked): When the value is locked, the functions of the TP are administratively disabled, i.e. the TP does not detect signal failures. The administrativeState has no effect on the operationalState;
  - operationalState (enabled, disabled): The operational state is disabled if a LOS is detected or if one of the objects pointed to by the attribute supportedByObjectList is in the operationalState disabled;
  - alarmStatus: has the value representing the severity of the most severe alarm currently detected by the object.
- upstreamConnectivityPointer: This has the value NULL set at instantiation;
- downstreamConnectivityPointer: This has the value NULL set at instantiation;
- interfaceTiming: This value controls the selection of interface timing mode (codirectional, contradirectional). The timing selection changes the line coding correspondingly.

##### Actions

- modify [administrativeState, interfaceTiming, alarmSeverityAssignment-ProfilePointer];
- get [pPITTPId, supportedByObjectList, alarmSeverity-AssignmentProfile-Pointer, administrativeState, operationalState, alarmStatus, upstream-ConnectivityPointer, downstreamConnectivityPointer, interfaceTiming].

##### Notifications

- objectCreation is issued when the instance is created;
- objectDeletion is issued when the instance is deleted;
- alarm notification (refers to CCITT Recommendation G.703 [1] alarms): A communicationsAlarm notification shall be issued in the case of a LOS. The probableCause parameter of the notification shall indicate LOS;

- stateChange: A stateChange notification is issued when the operationalState change in value;
- attributeValueChange is issued if any of the following attributes change in value: alarmStatus, alarmSeverityAssignmentProfilePointer, interfaceTiming.

### 7.3.2.3.2 pPIx24TTP (PI functional block)

#### Behaviour

This object class corresponds to the PI functional block located between reference points P and O of the functional diagram shown in figure 1 of ETS 300 461-1 [31] (part 1 of this ETS). It represents the point where the conversion between the interface signal and the internal logic level plus timing is performed. At point O, codirectional mode is assumed independently of timing mode at the physical interface. Octet timing (octet timing has no signalling function in this interface) is controlled in this block as well. This N x 64 kbit/s CCITT Recommendation X.24 [20] physical TTP object class is derived from the *pPITTPBidirectional* object class defined in ETS 300 371 [29]. This managed object may be automatically instantiated when the supporting managed object (transmission board) is instantiated.

#### Attributes

- pPITTPId: Logical identification of the TTP. This identification shall be unique for a FM;
- supportedByObjectList: The value of the supportedByObjectList attribute points to the *equipment* (transmission board) and *software* objects which implement the TP;
- alarmSeverityAssignmentProfilePointer: The value of this attribute points to the *alarmSeverityAssignmentProfile* object which identifies the alarm severity assignment profile related to this TP. If this attribute is not present, default severities are used;
- states of the access port (ITU-T Recommendation X.731):
  - administrativeState (locked, unlocked): When the value is locked, the functions of the TP are administratively disabled, i.e. the TP does not process the signal nor detects failure of the signal. The administrativeState has no effect on the operationalState;
  - operationalState (enabled, disabled): The operational state is disabled if a LOS (note 1) is detected or if one of the objects pointed to by the attribute supportedByObjectList is in the operationalState disabled;
  - alarmStatus: has the value representing the severity of the most severe alarm currently detected by the object;
- upstreamConnectivityPointer: This has the value NULL set at instantiation;
- downstreamConnectivityPointer: This has the value NULL set at instantiation;
- interfaceType: The value indicates the type of interface e.g. connector type in case more than one interface type is foreseen;
- interfaceTiming: This value controls the selection of interface timing mode (signalElementTiming(S), signalElementTiming(S) with octetTiming(B), externalTiming(X)) (note 2);

NOTE 1: Detection of LOS (loss of signal) is optional.

NOTE 2: Optional.

#### Operations

- modify [administrativeState, alarmSeverityAssignmentProfilePointer, interfaceTiming];
- get [pPITTPId, supportedByObjectList, alarmSeverity-AssignmentProfile-Pointer, administrativeState, operationalState, alarmStatus, interfaceType, upstreamConnectivityPointer, downstreamConnectivityPointer, interface-Timing].

## Notifications

- objectCreation is issued when the instance is created;
- objectDeletion is issued when the instance is deleted;
- alarm notification: A communicationsAlarm notification shall be issued if a LOS is detected. The probableCause parameter of the notification shall indicate LOS;
- stateChange: A stateChange Notification is issued when the operationalState change in value;
- attributeValueChange is issued if any of the following attributes change in value: alarmStatus, alarmSeverityAssignmentProfilePointer, interfaceTiming.

### 7.3.2.3.3 pPlv24v10v11TTP (PI functional block)

#### Behaviour

This object class corresponds to the PI functional block located between reference points P and O of the functional diagram shown in figure 1 of ETS 300 461-1 [31] (part 1 of this ETS). It represents the point where the conversion between the interface signal and the internal logic level plus timing is performed. At point O, codirectional mode is assumed independently of timing mode at the physical interface. Octet timing (octet timing has no signalling function in this interface) is controlled in this block as well. This N x 64 kbit/s V.24, V.10, V.11 physical TTP object class is derived from the *pPITTPBidirectional* object class defined in ETS 300 371 [29]. This managed object may be automatically instantiated when the supporting managed object (transmission board) is instantiated.

#### Attributes

- pPITTPId: Logical identification of the TTP. This identification shall be unique for a FM;
- supportedByObjectList: The value of the supportedByObjectList attribute points to the *equipment* (transmission board) and *software* objects which implement the TP;
- alarmSeverityAssignmentProfilePointer: The value of this attribute points to the *alarmSeverityAssignmentProfile* object which identifies the alarm severity assignment profile related to this TP. If this attribute is not present, default severities are used;
- states of the access port (ITU-T Recommendation X.731 [24]):
  - administrativeState (locked, unlocked): When the value is locked, the functions of the TP are administratively disabled, i.e. the TP does not process the signal nor detect failure of the signal. The administrativeState has no effect on the operationalState;
  - operationalState (enabled, disabled): The operational state is disabled if a LOS (note 1) is detected or if one of the objects pointed to by the attribute supportedByObjectList is in the operationalState disabled;
  - alarmStatus: has the value representing the severity of the most severe alarm currently detected by the object.
- upstreamConnectivityPointer: This has the value NULL set at instantiation;
- downstreamConnectivityPointer: This has the value NULL set at instantiation;
- interfaceType: The value indicates the type of interface e.g. connector type in case more than one interface type is foreseen;

- interfaceTiming: This value controls the selection of interface timing mode (codirectionalTiming(113/115,DCE) (note 2), contradirectionalTiming(114/115, DTE)).

NOTE 1: Detection of LOS is optional.

NOTE 2: Optional.

### Operations

- modify [administrativeState, alarmSeverityAssignmentProfilePointer, interfaceTiming];
- get [pPITTPId, supportedByObjectList, alarmSeverity-AssignmentProfile-Pointer, administrativeState, operationalState, alarmStatus, interfaceType, upstreamConnectivityPointer, downstreamConnectivityPointer, interface-Timing].

### Notifications

- objectCreation is issued when the instance is created;
- objectDeletion is issued when the instance is deleted;
- alarm notification: A communicationsAlarm notification shall be issued if a LOS is detected. The probableCause parameter of the notification shall indicate LOS;
- stateChange: A stateChange Notification is issued when the operationalState change in value;
- attributeValueChange is issued if any of the following attributes change in value: alarmStatus, alarmSeverityAssignmentProfilePointer.

#### 7.3.2.3.4 pPI2W4WTTP (PI functional block)

### Behaviour

This object class corresponds to the PI functional block located between reference points P and O of the functional diagram shown in figure 1 of ETS 300 461-1 [31] (part 1 of this ETS). It represents the point where the interface signal enters the unit. Test bus access and surge protection may be supported at this point. This 2W/4W physical TTP object class is derived from the *pPITTPBidirectional* object class defined in ETS 300 371 [29]. The managed object may be automatically instantiated when the supporting managed object (transmission board) is instantiated, depending on the make-up and operational mode of the FM.

### Attributes

- pPITTPId: Logical identification of the TTP. This identification shall be unique for a FM;
- supportedByObjectList: The value of the supportedByObjectList attribute points to the *equipment* (transmission board) and *software* objects which implement the TP;
- states of the access port (ITU-T Recommendation X.731 [24]):
  - administrativeState (locked, unlocked): When the value is locked, the functions of the TP are administratively disabled, i.e. the TP does not process the signal. The administrativeState has no effect on the operationalState;
  - operationalState (enabled, disabled): If one of the objects pointed to by the attribute supportedByObjectList is in the operationalState disabled.
- upstreamConnectivityPointer: This has the value NULL set at instantiation;
- downstreamConnectivityPointer: This has the value NULL set at instantiation;
- interfaceType: a string describing the type of VF interface.

### Test attributes

- lineTestAccess: Controls connection of the line to the test bus of the FM (NULL, busToLine, busToEquipment, lineMonitoring);
- testStatus (noTest, busToLine, busToEquipment, lineMonitoring): The value of this operational attribute indicates the type of the current connection between the 2W/4W Termination Point and a test Bus of the FM.

### Actions

- modify [administrativeState, alarmSeverityAssignmentProfilePointer, line-TestAccess];
- get [pPITTPId, supportedByObjectList, alarmSeverityAssignmentProfile-Pointer, administrativeState, operationalState, alarmStatus, upstream-ConnectivityPointer, downstreamConnectivityPointer, interfaceType, test-Status].

### Notifications

- objectCreation is issued when the instance is created;
- objectDeletion is issued when the instance is deleted;
- stateChange: A stateChange Notification is issued when the operationalState change in value;
- attributeValueChange is issued if any of the following attributes change in value: alarmStatus, interfaceType, alarmSeverityAssignmentProfilePointer, testStatus.

#### 7.3.2.3.5 pPI2W4WDCTTP (PI functional block)

### Behaviour

This object class corresponds to the PI functional block located between reference points P and O of the functional diagram shown in figure 1 of ETS 300 461-1 [31] (part 1 of this ETS). It represents the point where the interface signal enters the unit. Test bus access and surge protection may be supported at this point. This 2W/4W with DC signalling physical TTP object class is derived from the *pPITTPBidirectional* object class defined in ETS 300 371 [29]. This managed object may be automatically instantiated when the supporting managed object (transmission board) is instantiated, depending on the make-up and operational mode of the FM.

### Attributes

- pPITTPId: Logical identification of the TTP. This identification shall be unique for a FM;
- supportedByObjectList: The value of the supportedByObjectList attribute points to the *equipment* (transmission board) and *software* objects which implement the TP;
- states of the access port (ITU-T Recommendation X.731 [24]):
  - administrativeState (locked, unlocked): When the value is locked, the functions of the TP are administratively disabled, i.e. the TP does not process the signal. The administrativeState has no effect on the operationalState;
  - operationalState (enabled, disabled): If one of the objects pointed to by the attribute supportedByObjectList is in the operationalState disabled.
- upstreamConnectivityPointer: This has the value NULL set at instantiation;
- downstreamConnectivityPointer: This has the value NULL set at instantiation;
- interfaceType: A string describing the type of VF interface.

### Test attributes

- lineTestAccess: controls connection of the line to the test bus of the FM (NULL, busToLine, busToEquipment, lineMonitoring);
- testStatus (noTest, busToLine, busToEquipment, lineMonitoring): The value of this operational attribute indicates the type of the current connection between the 2W/4W Termination Point and a test Bus of the FM.

### Actions

- modify [administrativeState, alarmSeverityAssignmentProfilePointer, line-TestAccess];
- get [pPITTPId, supportedByObjectList, alarmSeverityAssignmentProfile-Pointer, administrativeState, operationalState, alarmStatus, upstream-ConnectivityPointer, downstreamConnectivityPointer, interfaceType, testStatus].

### Notifications

- objectCreation is issued when the instance is created;
- objectDeletion is issued when the instance is deleted;
- stateChange: A stateChange Notification is issued when the operationalState change in value;
- attributeValueChange is issued if any of the following attributes change in value: alarmStatus, interfaceType, alarmSeverityAssignmentProfilePointer, testStatus.

#### 7.3.2.3.6 pPI4WG722TTP (PI functional block)

### Behaviour

This object class corresponds to the PI functional block located between reference points P and O of the functional diagram shown in figure 1 of ETS 300 461-1 [31] (part 1 of this ETS). It represents the point where the interface signal enters the unit. Test bus access and surge protection may be supported at this point. This 4W physical TTP object class is derived from the *pPITTPBidirectional* object class defined in ETS 300 371 [29]. This managed object may be automatically instantiated when the supporting managed object (transmission board) is instantiated, depending on the make-up and operational mode of the FM.

### Attributes

- pPITTPId: Logical identification of the TTP. This identification shall be unique for a FM;
- supportedByObjectList: The value of the supportedByObjectList attribute points to the *equipment* (transmission board) and *software* objects which implement the TP;
- states of the access port (ITU-T Recommendation X.731 [24]):
  - administrativeState (locked, unlocked): When the value is locked, the functions of the TP are administratively disabled, i.e. the TP does not process the signal. The administrativeState has no effect on the operationalState;
  - operationalState (enabled, disabled): If one of the objects pointed to by the attribute supportedByObjectList is in the operationalState disabled.
- upstreamConnectivityPointer: This has the value NULL set at instantiation;
- downstreamConnectivityPointer: This has the value NULL set at instantiation;
- interfaceType: A string describing the type of VF interface.

### Test attributes

- lineTestAccess: controls connection of the line to the test bus of the FM (NULL, busToLine, busToEquipment, lineMonitoring);
- testStatus (noTest, busToLine, busToEquipment, lineMonitoring): The value of this operational attribute indicates the type of the current connection between the 4W Termination Point and a test Bus of the FM.

### Actions

- modify [administrativeState, alarmSeverityAssignmentProfilePointer, line-TestAccess];
- get [pPITTPId supportedByObjectList, alarmSeverityAssignmentProfile-Pointer, administrativeState, operationalState, alarmStatus, upstream-ConnectivityPointer, downstreamConnectivityPointer, interfaceType, testStatus].

### Notifications

- objectCreation is issued when the instance is created;
- objectDeletion is issued when the instance is deleted;
- stateChange: A stateChange Notification is issued when the operationalState change in value;
- attributeValueChange is issued if any of the following attributes change in value: alarmStatus, interfaceType, alarmSeverityAssignmentProfilePointer, testStatus.

#### 7.3.2.3.7 G703aF (TPT/TST functional block)

### Behaviour

This object class corresponds to the TPT/TST functional block located between reference points O and N of the functional diagram shown in figure 1 of ETS 300 461-1 [31] (part 1 of this ETS). It represents the point where the tributary information and control signals are generated or terminated. This 64 kbit/s CCITT Recommendation G.703 [1] tributary adaptation. This managed object is automatically instantiated when the superior managed object (*pPIOG703TTP*) is instantiated.

### Attributes

- G703aFId: Logical identification of the aF (value = 1);
- supportedByObjectList: The value of the supportedByObjectList attribute points to the *equipment* (transmission board) and *software* objects which implement the aF;
- alarmSeverityAssignmentProfilePointer: The value of this attribute points to the *alarmSeverityAssignmentProfile* object which identifies the alarm severity assignment profile related to this aF. If this attribute is not present, default severities are used;
- states of the access function (ITU-T Recommendation X.731 [24]):
  - operationalState (enabled, disabled): The operational state is disabled if LossOfOctetTiming (LOOT) is detected or if one of the objects pointed to by the attribute supportedByObjectList is in the operationalState disabled;
  - alarmStatus: has the value representing the severity of the most severe alarm currently detected by the object.
- upstreamConnectivityPointer: This has the value NULL set at instantiation;
- downstreamConnectivityPointer: This has the value NULL set at instantiation;



- octetTimingTx: This attribute controls usage of octet timing at the physical output (fixedON, fixedOFF, alarmControlled). Octet timing can be set to permanently ON or OFF (no octet timing) or controlled by the alarm state of the interface (CCITT Recommendation G.703 [1]);
- octetTimingRx: This attribute controls monitoring of octet timing at the physical input (NULL, disabled, enabled). Octet timing is monitored in enabled mode only. NULL indicates not supported.

NOTE: Detection of LOOT is optional.

#### Test attributes

- lineLoopSet: The value of this attribute controls looping of the line signal back to the line (activate, deactivate);
- equipmentLoopSet: This attribute controls looping of the signal from the equipment back to the equipment (activate, deactivate);
- loopState (NULL, loopType): The value of this attribute indicates if a loop is present on the interface. In the case of a loop being present, the loopType value indicates the orientation of the loop (localEquipmentSide, localLineSide). A change in the value of the loopState attribute shall cause an attributeValueChange notification;
- loopTime: The value of this attribute restricts the duration of a loop to N seconds (N: 1 to 1 000). The value NULL indicates no time limitation.

#### Actions

- modify [administrativeState, alarmSeverityAssignmentProfilePointer, octet-TimingTx, octetTimingRx, lineLoopSet, equipmentLoopSet, loopTime];
- get [G703aFId, supportedByObjectList, alarmSeverityAssignmentProfile-Pointer, administrativeState, operationalState, alarmStatus, upstream-ConnectivityPointer, downstreamConnectivityPointer, octetTimingTx, octetTimingRx, loopState, loopTime].

#### Notifications

- objectCreation is issued when the instance is created;
- objectDeletion is issued when the instance is deleted;
- alarm notification (refers to CCITT Recommendation G.703 [1] alarms): A communicationsAlarm notification shall be issued if a LOOT is detected. The probableCause parameter of the notification shall indicate LOOT;
- stateChange: A stateChange Notification is issued when the operationalState change in value;
- attributeValueChange is issued if any of the following attributes change in value: alarmStatus, alarmSeverityAssignmentProfilePointer, octetTimingTx, octetTimingRx, loopState.

#### 7.3.2.3.8 x24aF (TPT/TST functional block)

##### Behaviour

This N x 64 kbit/s CCITT Recommendation X.24 [20] adaptation Function (aF) object class corresponds to the TPT/TST functional block located between reference points P and O of the functional diagram shown in figure 1 of ETS 300 461-1 [31] (part 1 of this ETS). It represents the point where the conversion between the interface signal and the internal logic level plus timing is performed. At point O, codirectional mode is assumed independently of timing mode at the physical interface. Octet timing (octet timing has no signalling function in this interface) is controlled in this block as well. This managed object is automatically instantiated when the superior managed object (*pPIx24TTP*) is instantiated.

### Attributes

- x24aFld: Logical identification of the aF (value: 1);
- supportedByObjectList: The value of the supportedByObjectList attribute points to the *equipment* (transmission board) and *software* objects which implement the TP;
- alarmSeverityAssignmentProfilePointer: The value of this attribute points to the *alarmSeverityAssignmentProfile* object which identifies the alarm severity assignment profile related to this TP. If this attribute is not present, default severities are used;
- upstreamConnectivityPointer: This has the value NULL set at instantiation;
- downstreamConnectivityPointer: This has the value NULL set at instantiation;
- interfaceType: The value controls the selection of interface e.g. connector type. If the type is not selectable the attribute is read only;
- bitRate: The value of this attribute indicates the bit rate integer N of N x 64 kbit/s. N can always take values 1 to 30. When mapping to an aggregate with CAS signalling in TS16 is turned off, N can also take the value 31;
- CUsage: The value of this attribute selects usage of the control signal C (Control), the related signal value appears at reference point N1 for transmission to the far-end (fixedON, fixedOFF, CEnabled);
- IUsage: The value of this attribute selects usage of the control signal I (Indication). The related signal value appears at reference point O to be sent to the local physical interface I (fixedON, fixedOFF, IEnabled). In IEnabled mode the control signal is transferred from the far-end using: a simulated carrier, CAS bits or some other method;
- interfaceSignalValues: The value of this attribute indicates the actual state of data interface signals. Each interface signal (R, T, I, C, S, B/X) can take 4 states (NULL, ON, OFF, toggling). NULL indicates not applicable.

### Test attributes

- loop3cSet: The interfaceLoop3cSet attribute controls activation of a 3c/CCITT Recommendation X.150 [21] loop from reference point O to the physical interface;
- loop2bSet: The interfaceLoop2bSet attribute controls activation of a 2b/CCITT Recommendation X.150 [21] from reference point O to the remote end;
- enableLoop3: The enableLoop3 attribute enables a user to activate a 3 loop using interface signals (loop3Disabled, loop3bEnabled, loop3cEnabled);
- enableLoop2b: The enableLoop2b attribute enables a user to activate a 2b loop using interface signals at the far end (loop2bDisabled, loop2bEnabled);
- loopState (NULL, loopType, loopOrigin): The value of this attribute indicates if a loop is present on the interface. In the case of a loop being present, the loopType value indicates the orientation of the loop (loop3c, loop3b, loop2) and the loopOrigin indicates the origin of the loop request (operationsSystem, user). A change in the value of the loopState attribute shall cause an attributeValueChange notification;
- loopTime: The value of this attribute restricts the duration of a loop to N seconds (N = 1 to 1 000). The value NULL indicates no time limitation.

## Operations

- modify [administrativeState, alarmSeverityAssignmentProfilePointer, bitRate, CUsage, IUsage, loop3cSet, loop2bSet, enableLoop3, enableLoop2b, loopTime];
- get [x24aFId, accessPort, supportedByObjectList, alarmSeverity-AssignmentProfilePointer, administrativeState, operationalState, alarmStatus, interfaceType, upstreamConnectivityPointer, downstreamConnectivity-Pointer, bitRate, CUsage, IUsage, interfaceSignalValues, enableLoop3, enableLoop2b, loopStatus, loopTime].

## Notifications

- objectCreation is issued when the instance is created;
- objectDeletion is issued when the instance is deleted;
- stateChange: A stateChange Notification is issued when the operationalState changes value;
- attributeValueChange is issued if any of the following attributes change in value: alarmStatus, alarmSeverityAssignmentProfilePointer, bitRate, CUsage, IUsage, enableLoop3, enableLoop2b, loopState, loopTime.

### 7.3.2.3.9 v24aF (TPT/TST functional block)

#### Behaviour

This N x 64 kbit/s ITU-T Recommendation V.24 [17] adaptation Function (aF) object class corresponds to the TPT/TST functional block located between reference points P and O of the functional diagram shown in figure 1 of ETS 300 461-1 [31] (part 1 of this ETS). It represents the point where the conversion between the interface signal and the internal logic level plus timing is performed. At point O, codirectional mode is assumed independently of timing mode at the physical interface. Octet timing (octet timing has no signalling function in this interface) is controlled in this block as well. This managed object is automatically instantiated when the superior managed object (*pPIv24v10v11TTP*) is instantiated.

#### Attributes

- v24aFId: Logical identification of the aF (value = 1);
- supportedByObjectList: The value of the supportedByObjectList attribute points to the *equipment* (transmission board) and *software* objects which implement the TP;
- alarmSeverityAssignmentProfilePointer: The value of this attribute points to the *alarmSeverityAssignmentProfile* object which identifies the alarm severity assignment profile related to this TP. If this attribute is not present, default severities are used;
- upstreamConnectivityPointer: This has the value NULL set at instantiation;
- downstreamConnectivityPointer: This has the value NULL set at instantiation;
- bitRate: The value of this attribute indicates the bit rate integer N of N x 64 kbit/s. N can always take values 1 to 30. When mapping to an aggregate with CAS signalling in TS16 turned off, N can also take the value 31;
- 105Usage: The value of this attribute selects usage of the control signal 105, the related signal value appears at reference point N1 for transmission to the far-end (fixedON, fixedOFF, 105Enabled);
- Usage106: The value of this attribute selects usage of the control signal 106. The related signal value appears at reference point O to be sent to the local physical interface 106 (fixedON, fixedOFF, 106localEnabled (controlled by 105), 106remoteEnabled (controlled via a controlsignal channel));

- 106Delay: The value of this attribute selects the delay between turn ON of 105 to turn ON of 106. The delay value selects the 105-106 delay in steps of 0,1 ms between (0,1 ms to 500 ms). The value NULL indicates no delay. 106Delay is selectable only when the value of Usage106 "106localEnabled" is selected. In all other cases 106Delay is forced to NULL;
- 109Usage: The value of this attribute selects usage of the control signal 109. The related signal value appears at reference point O to be sent to the local physical interface 109 (fixedON, fixedOFF, 109Enabled). In 109Enabled mode the control signal is transferred from the far-end using: a simulated carrier, CAS bits or some other method;
- 107Usage: The value of this attribute controls usage of the 107 (DSR) signal. The related signal value appears at reference point O to be sent to the local physical interface 107 (fixedON, fixedOFF, 107Enabled). In 107Enabled mode 107 is turned ON when the circuit is ready to transfer data and turned OFF in fault conditions and when the circuit is missing or not ready for data transfer;
- interfaceSignalValues: The value of this attribute indicates the actual state of data interface signals. Each interface signal (103, 104, 105, 106, 107, 109, 113, 114, 115, 140, 141, 142) can take 4 states (NULL, ON, OFF, toggling). NULL indicates not applicable.

### Test attributes

- loop3cSet: The interfaceLoop3cSet attribute controls activation of a 3c/CCITT Recommendation X.150 [21] loop from reference point O to the physical interface;
- loop2bSet: The interfaceLoop2bSet attribute controls activation of a 2b/CCITT Recommendation X.150 [21] from reference point O to the remote end;
- enableLoop3: The enableLoop3 attribute enables a user to activate a 3 loop using interface signals (loop3Disabled, loop3bEnabled, loop3cEnabled);
- enableLoop2b: The enableLoop2b attribute enables a user to activate a 2b loop using interface signals at the far end (loop2bDisabled, loop2bEnabled);
- loopState (NULL, loopType, loopOrigin): The value of this attribute indicates if a loop is present on the interface. In the case where a loop is present, the loopType value indicates the orientation of the loop (loop3c, loop3b, loop2b) and the loopOrigin indicates the origin of the loop request (operationsSystem, user). A change in the value of the loopState attribute shall cause an attributeValueChange notification;
- loopTime: The value of this attribute restricts the duration of a loop to N seconds (N = 1 to 1 000). The value NULL indicates no time limitation.

### Operations

- modify [administrativeState, alarmSeverityAssignmentProfilePointer, bitRate, 105Usage, 106Usage, 106Delay, 109Usage, 107Usage, loop3bSet, loop2b-Set, enableLoop3, enableLoop2b, loop-Time];
- Get [v24aFId, accessPort, supportedByObjectList, alarmSeverity-AssignmentProfilePointer, administrativeState, operationalState, alarmStatus, upstreamConnectivityPointer, downstreamConnectivity-Pointer, 105Usage, 106Usage, 106Delay, 109Usage, 107Usage, interfaceSignalValues, enable-Loop3, enableLoop2b, loopState, loopTime].

## Notifications

- objectCreation is issued when the instance is created;
- objectDeletion is issued when the instance is deleted;
- stateChange: A stateChange Notification is issued when the operationalState changes value;
- attributeValueChange is issued if any of the following attributes change in value: alarmStatus, alarmSeverityAssignmentProfilePointer, bitRate, 105Usage, 106Usage, 106Delay, 109Usage, 107Usage, enableLoop3, enable-Loop2b, loopState, loopTime.

### 7.3.2.3.10 2W4WaF (TPT/TST voice band functional block)

#### Behaviour

This object class corresponds to the TPT/TST functional block located between reference points O and N of the functional diagram shown in figure 1 of ETS 300 461-1 [31] (part 1 of this ETS). It represents the Voice Band TTP on a 2W4WaF. The object controls selection between 2W and 4W operation and setting of relative VF levels of the physical interface. At reference point N the signal is always presented in 4W mode with standard 0 dbr levels in both transmit and receive directions. This managed object is automatically instantiated when the superior managed object (*pPI2W4WTTP*) is instantiated.

#### Attributes

- 2W4WaFId: Logical identification of the TP (value = 1);
- supportedByObjectList: The value of the supportedByObjectList attribute points to the *equipment* (transmission board) and *software* objects which implement the TP;
- upstreamConnectivityPointer: This value is the address of an object which receives traffic from this object or NULL;
- downstreamConnectivityPointer: This value is the address of an object which receives traffic from this object or NULL;
- 2w4wOperation: The value of this attribute indicates the selected mode of operation (2W or 4W);
- inputRelativeLevel: The value of this attribute indicates the selected relative input level (note);
- outputRelativeLevel: The value of this attribute indicates the selected relative output level (note);
- minInputRelativeLevel: The value of this attribute indicates the minimum possible relative input level (note);
- minOutputRelativeLevel: The value of this attribute indicates the minimum possible relative output level (note);
- maxInputRelativeLevel: The value of this attribute indicates the maximum possible relative input level (note);
- maxOutputRelativeLevel: The value of this attribute indicates the maximum possible relative output level (note).

NOTE: The relative levels are given in format  $\pm XX,X$  dBr. The maximum and minimum values depend on the actual interface type.

### Conditional attributes applicable in 2W operation only

- balanceImpedance: The value of this attribute indicates the hybrid balance impedance in 2W operation. The set of available balance impedances is application specific. The impedance is described by a string;
- balanceImpedanceList: This attribute lists the balance impedance supported (list of strings). It is applicable in 2W operation only.

### Other conditional attributes

- inputImpedance: The value of this attribute indicates the input impedance of the VF interface. The impedance value may or may not be configurable. The impedance values are described by a string;
- outputImpedance: This attribute lists the output impedance of the VF interface.

### Test attributes

- analogEquipmentLoop: This attribute can activate an analogue test loop at reference point O to the VF interface. The loop is allowed in 4W mode only;
- loopTime: This attribute limits the looping time. When the time expires the loop is automatically reset. Value NULL indicates no time limit. The time is given in seconds (1 to 1 000 seconds);
- loopState (NULL, loopType): The value of this attribute indicates if a loop is present on the interface. In the case where a loop is present, the loopType value indicates the orientation of the loop (analogEquipmentLoop). A change in the value of the loopState attribute shall cause an attributeValueChange notification.

### Operations

- modify [2w4wOperation, balanceImpedance, inputRelativeLevel, outputRelativeLevel, inputImpedance, outputImpedance, analogInterface-Loop, loopTime];
- get [2W4WaFId, supportedByObjectList, administrativeState, operationalState, alarmStatus, 2w4wOperation, balanceImpedance, balance-ImpedanceList, inputRelativeLevel, outputRelativeLevel, minInputRelative-Level, minOutputRelativeLevel, maxInputRelativeLevel, maxOutputRelative-Level, inputImpedance, outputImpedance, loopState, loopTime].

### Notifications

- objectCreation is issued when the instance is created;
- objectDeletion is issued when the instance is deleted;
- stateChange: A stateChange notification is issued when the operationalState change in value;
- attributeValueChange is issued if any of the following attributes change in value: alarmStatus, alarmSeverityAssignmentProfilePointer, relativeInput-Level, relativeOutputLevel, balanceImpedance, 2W/4W operation, input-Impedance, outputImpedance or loopState, loopTime.

### 7.3.2.3.11 2W4WDCaF (voice band and DC signalling functional block)

#### Behaviour

This object class corresponds to the TPT/TST functional block located between reference points O and N of the functional diagram shown in figure 1 of ETS 300 461-1 [31] (part 1 of this ETS). It represents the VF TTP on a 2W4WDCaF. The object controls selection between 2W and 4W operation and setting of relative VF levels of the physical interface. At reference point N the signal is always presented in 4W mode with standard 0 dbr levels in both transmit and receive directions. At this point the logical signalling data is transformed to signalling criteria (voltages, currents, impedances), these signalling criteria are subsequently converted to logic signals. Additional attributes may be required in some applications to control e.g. the loop current or impedances. This managed object is automatically instantiated when the superior managed object (*pPI2W4WDCTTP*) is instantiated.

#### Attributes

- *2W4WDCaFID*: Logical identification of the TP (value = 1);
- *supportedByObjectList*: The value of the *supportedByObjectList* attribute points to the *equipment* (transmission board) and *software* objects which implement the TP;
- *upstreamConnectivityPointer*: This value is the address of an object which receives traffic from this object or NULL;
- *downstreamConnectivityPointer*: This value is the address of an object which receives traffic from this object or NULL;
- *2w4wOperation*: The value of this attribute indicates the selected mode of operation (2W or 4W);
- *inputRelativeLevel*: The value of this attribute indicates the selected relative input level (note);
- *outputRelativeLevel*: The value of this attribute indicates the selected relative output level (note);
- *minInputRelativeLevel*: The value of this attribute indicates the minimum possible relative input level (note);
- *minOutputRelativeLevel*: The value of this attribute indicates the minimum possible relative output level (note);
- *maxInputRelativeLevel*: The value of this attribute indicates the maximum possible relative input level (note);
- *maxOutputRelativeLevel*: The value of this attribute indicates the maximum possible relative output level (note).

NOTE: The relative levels are given in format  $\pm XX,X$  dBr. The maximum and minimum values depend on the actual interface type.

#### Conditional attributes applicable in 2W operation only

- *balanceImpedance*: The value of this attribute indicates the hybrid balance impedance in 2W operation. The set of available balance impedances is application specific. The impedance is described by a string;
- *balanceImpedanceList*: This attribute lists the balance impedance supported (list of strings). This attribute is applicable in 2W operation only.

### Other conditional attributes

- inputImpedance: The value of this attribute indicates the input impedance of the VF interface. The impedance value may or may not be configurable. The impedance values are described by a string;
- outputImpedance: This attribute lists the output impedance of the VF interface. The impedance value may or may not be configurable. The impedance values are described by a string.

### Test attributes

- analogEquipmentLoop: This attribute can activate an analogue test loop at reference point O to the VF interface. The loop is allowed in 4W mode only;
- loopTime: This attribute limits the looping time. When the time expires the loop is automatically reset. Value NULL indicates no time limit. The time is given in seconds (1 to 1 000 seconds);
- loopState (NULL, loopType): The value of this attribute indicates if a loop is present on the interface. In the case where a loop is present, the loopType value indicates the orientation of the loop (analogEquipmentLoop). A change in the value of the loopState attribute shall cause an attributeValueChange notification.

### Operations

- modify [2w4wOperation, balanceImpedance, inputRelativeLevel, outputRelativeLevel, inputImpedance, outputImpedance, analogInterface-Loop, loopTime];
- get [2W4WDCaFId, supportedByObjectList, administrativeState, operationalState, alarmStatus, 2w4wOperation, balanceImpedance, balance-ImpedanceList, inputRelativeLevel, outputRelativeLevel, minInputRelative-Level, minOutputRelativeLevel, maxInputRelativeLevel, maxOutputRelative-Level, inputImpedance, outputImpedance, loopState, loopTime].

### Notifications

- objectCreation is issued when the instance is created;
- objectDeletion is issued when the instance is deleted;
- stateChange: A stateChange Notification is issued when the operationalState changes value;
- attributeValueChange is issued if any of the following attributes change in value: alarmStatus, alarmSeverityAssignmentProfilePointer, relativeInput-Level, relativeOutputLevel, balanceImpedance, 2W/4W operation, input-Impedance, outputImpedance, loopState, loopTime.

#### 7.3.2.3.12 4WG722aF (wide band functional block)

### Behaviour

This object class corresponds to the TPT/TST functional block located between reference points O and N of the functional diagram shown in figure 1 of ETS 300 461-1 [31] (part 1 of this ETS). It represents the Wide Band TTP on a 4WG722aF. The object controls setting of relative VF levels of the physical interface. At reference point N the signal is always presented in 4W mode with standard 0 dbr levels in both transmit and receive directions. This managed object is automatically instantiated when the superior managed object (*pPI4G722TTP*) is instantiated.

### Attributes

- 4WG722aFId: Logical identification of the termination point (value = 1);
- supportedByObjectList: The value of the supportedByObjectList attribute points to the *equipment* (transmission board) and *software* objects which implement the TP;
- upstreamConnectivityPointer: This value is the address of an object which receives traffic from this object or NULL;



- downstreamConnectivityPointer: This value is the address of an object which receives traffic from this object or NULL;
- inputRelativeLevel: The value of this attribute indicates the selected relative input level (note);
- outputRelativeLevel: The value of this attribute indicates the selected relative output level (note);
- minInputRelativeLevel: The value of this attribute indicates the minimum possible relative input level (note);
- minOutputRelativeLevel: The value of this attribute indicates the minimum possible relative output level (note);
- maxInputRelativeLevel: The value of this attribute indicates the maximum possible relative input level (note);
- maxOutputRelativeLevel: The value of this attribute indicates the maximum possible relative output level (note).

NOTE: The relative levels are given in format  $\pm XX,X$  dBr. The maximum and minimum values depend on the actual interface type.

### Test attributes

- analogEquipmentLoop: This attribute can activate an analogue test loop from reference point O towards the VF interface;
- loopTime: This attribute limits the looping time. When the time expires the loop is automatically reset. Value NULL indicates no time limit. The time is given in seconds (1 to 1 000 seconds);
- loopState (NULL, loopType): The value of this attribute indicates if a loop is present on the interface. In the case where a loop is present, the loopType value indicates the orientation of the loop (analogEquipmentLoop). A change in the value of the loopState attribute shall cause an attributeValueChange notification.

### Operations

- modify [inputRelativeLevel, outputRelativeLevel, analogInterfaceLoop, loopTime];
- get [WBaFId, supportedByObjectList, administrativeState, operationalState, alarmStatus, upstreamConnectivityPointer, downstreamConnectivityPointer, inputRelativeLevel, outputRelativeLevel, minInputRelativeLevel, minOutput-RelativeLevel, maxInputRelativeLevel, maxOutputRelativeLevel, loopState, loopTime].

### Notifications

- objectCreation is issued when the instance is created;
- objectDeletion is issued when the instance is deleted;
- stateChange: A stateChange notification is issued when the operationalState change in value;
- attributeValueChange is issued if any of the following attributes change in value: alarmStatus, alarmSeverity-AssignmentProfilePointer, relativeLevel, outputImpedance, analogInterface-Loop.

### 7.3.2.3.13 e0tCTP (tributary CTP at 64 kbit/s)

#### Behaviour

An instance of this object class corresponds to the TPT/TST functional block of the functional diagram shown in figure 1 of ETS 300 461-1 [31] (part 1 of this ETS). It originates and terminates a 64 kbit/s tributary connection. It represents the 64 kbit/s CTP. This 64 kbit/s CTP object class is derived from the *ePDHCTPBidirectional* object class defined in the ETS 300 371 [29]. This managed object is automatically instantiated when the superior managed object (*aF*) is instantiated.

#### Attributes

- e0CTPId: Logical identification of the TP (value = 1);
- supportedByObjectList: The value of the supportedByObjectList attribute points to the *equipment* (transmission board) and *software* objects which implement the TP;
- characteristicInformation (N x 64 kbit/s, NxCAS/noCAS): The value of this attribute is used to verify the connectability of the connection point;
- crossConnectionObjectPointer: The value of this attribute points to a *crossConnection*, *Fabric* or a *gtp* object;
- bitRate: The value of this attribute indicates the integer N of N x 64 kbit/s, N = 1 for this interface;
- upstreamConnectivityPointer: This has the value NULL set at instantiation;
- downstreamConnectivityPointer: This has the value NULL set at instantiation.

#### Test attributes

- loop3bSet: The interfaceLoop3bSet attribute controls activation of a 3b/CCITT Recommendation X.150 [21] loop from reference point N to the physical interface;
- loopState (NULL, loopType, loopOrigin): The value of this attribute indicates if a loop is present on the interface. In the case where a loop is present, the loopType value indicates the orientation of the loop (loop3c, loop3b, loop2) and the loopOrigin indicates the origin of the loop request (operationsSystem, user). A change in the value of the loopState attribute shall cause an attributeValueChange notification;
- loopTime: The value of this attribute restricts the duration of a loop to N seconds (N = 1 to 1 000). The value NULL indicates no time limitation.

#### Operations

- modify [downstreamConnectivityPointer, loop3bSet, loopTime];
- get [e0CTPId, supportedByObjectList, bitRate, upstreamConnectivity-Pointer, downstreamConnectivityPointer, loopState, loopTime].

#### Notifications

- objectCreation is issued when the instance is created;
- objectDeletion is issued when the instance is deleted;
- attributeValueChange is issued if any of the following attributes change in value: crossConnectionObjectPointer, loopState, loopTime.

### 7.3.2.3.14 eNx0tCTP (tributary CTP at N x 64 kbit/s)

#### Behaviour

An instance of this object class originates and terminates a N x 64 kbit/s tributary connection. It represents the N x 64 kbit/s tributary TTP on an aF which is used for cross-connection of N x 64 kbit/s signals (signals at reference points N/M in the functional diagram shown in figure 1 of ETS 300 461-1 [31] (part 1 of this ETS)). This N x 64 kbit/s tributary CTP object class is derived from the *eOCTPBidirectional* object class defined in ETS 300 371 [29]. This managed object is automatically instantiated when the superior managed object (aF) is instantiated.

#### Attributes

- eNx0tCTPId: Logical identification of the TP (value = 1);
- supportedByObjectList: The value of the supportedByObjectList attribute points to the *equipment* (transmission board) and *software* objects which implement the TP;
- characteristicInformation (N x 64 kbit/s, NxCAS/noCAS): The value of this attribute is used to verify the connectability of the connection point;
- crossConnectionObjectPointer: The value of this attribute points to a *crossConnection*, *Fabric* or a *gtp* object;
- bitRate: The value of this attribute indicates the integer N of N x 64 kbit/s, (N = 1 to 31);
- upstreamConnectivityPointer: This has the value NULL set at instantiation;
- downstreamConnectivityPointer: This has the value NULL set at instantiation.

#### Test attributes

- loop3bSet: The interfaceLoop3bSet attribute controls activation of a 3b/CCITT Recommendation X.150 [21] loop from reference point XC towards the physical interface;
- loopState (NULL, loopType, loopOrigin): The value of this attribute indicates if a loop is present on the interface. In the case where a loop is present, the loopType value indicates the orientation of the loop (loop3c, loop3b, loop2) and the loopOrigin indicates the origin of the loop request (operationsSystem, user). A change in the value of the loopState attribute shall cause an attributeValueChange notification;
- loopTime: The value of this attribute restricts the duration of a loop to N seconds (N = 1 to 1 000). The value NULL indicates no time limitation.

#### Operations

- modify [crossConnectionObjectPointer, loop3bSet, loopTime];
- get [eNx0tCTPId, supportedByObjectList, characteristicInformation, crossConnectionObjectPointer, bitRate, upstreamConnectivityPointer, downstreamConnectivityPointer, loopState, loopTime].

#### Notifications

- objectCreation is issued when the instance is created;
- objectDeletion is issued when the instance is deleted;
- attributeValueChange is issued if any of the following attributes change in value: crossConnectionObjectPointer, loopState, loopTime.

### 7.3.2.3.15 e00VBCTP (voice band CTP)

#### Behaviour

An instance of this object class originates and terminates a voice band link connection. It represents the voice band CTP on an e0G711ALTTP. It is used for interconnecting the voice band ALawPathTrail with the voice band interface of the e00VBtCTP on a tributary aF at reference point N. This voice band connection point object class is a specialized *ePDHCTPBidirectional* defined in the ETS 300 371 [29]. This managed object is automatically instantiated when the superior managed object (e0G711) is instantiated.

#### Attributes

- ePDHCTPId: Logical identification of the TP (value = 1);
- upstreamConnectivityPointer: This has the value NULL set at instantiation;
- downstreamConnectivityPointer: This has the value NULL set at instantiation.

#### Test attributes

- analogCodecLoopSet: This attribute can activate an analogue test loop from reference point N towards the VF codec;
- loopTime: This attribute limits the looping time. When the time expires the loop is automatically reset. Value NULL indicates no time limit. The time is given in seconds (1 to 1 000 seconds);
- loopState (NULL, loopType): The value of this attribute indicates if a loop is present on the interface. In the case where a loop is present, the loopType value indicates the orientation of the loop (analogEquipmentLoop). A change in the value of the loopState attribute shall cause an attributeValueChange notification.

#### Operations

- modify [analogCodecLoopSet, loopTime];
- get [ePDHCTPId, upstreamConnectivityPointer, downstreamConnectivity-Pointer, loopState, loopTime].

#### Notifications

- objectCreation is issued when the instance is created;
- objectDeletion is issued when the instance is deleted;
- attributeValueChange is issued if any of the following attributes change in value: analogCodecLoopSet, loopTime.

### 7.3.2.3.16 e00VBtCTP (voice band tributary CTP)

#### Behaviour

An instance of this object class originates and terminates a voice band link connection. It represents the voice band tributary CTP on a aF. It is used for interconnecting the tributary voice band physical trail with the voice band interface of an e00VBCTP at reference point N. This voice band tributary connection point object class is derived from the *ePDHCTPBidirectional* defined in the ETS 300 371 [29]. This managed object is automatically instantiated when the superior managed object (aF) is instantiated.

### Attributes

- ePDHCTPId: Logical identification of the TP (value = 1);
- upstreamConnectivityPointer: This has the value NULL set at instantiation;
- downstreamConnectivityPointer: This has the value NULL set at instantiation.

### Operations

- Get [ePDHCTPId, upstreamConnectivityPointer, downstreamConnectivity-Pointer].

### Notifications

- objectCreation is issued when the instance is created;
- objectDeletion is issued when the instance is deleted.

### 7.3.2.3.17 e00WBCTP (wide band CTP)

#### Behaviour

An instance of this object class originates and terminates a wide band link connection. It represents the wide band CTP on an e0G722TTP. It is used for interconnecting the wide band trail with the wide band interface of the e00WBtCTP on an aF at reference point N. This wide band connection point object class is derived from the *ePDHCTPBidirectional* defined in the ETS 300 371 [29]. This managed object is automatically instantiated when the superior managed object (e0G722TTP) is instantiated.

#### Attributes

- ePDHCTPId: Logical identification of the TP (value = 1);
- supportedByObjectList: The value of the supportedByObjectList attribute points to the *equipment* (transmission board) and *software* objects which implement the TP;
- upstreamConnectivityPointer: This has the value NULL set at instantiation;
- downstreamConnectivityPointer: This has the value NULL set at instantiation.

#### Test attributes

- analogCodecLoopSet: This attribute can activate an analogue test loop from reference point N towards the VF codec;
- loopTime: This attribute limits the looping time. When the time expires the loop is automatically reset. Value NULL indicates no time limit. The time is given in seconds (1 to 1 000 seconds);
- loopState (NULL, loopType): The value of this attribute indicates if a loop is present on the interface. In the case where a loop is present, the loopType value indicates the orientation of the loop (analogEquipmentLoop). A change in the value of the loopState attribute shall cause an attributeValueChange notification.

#### Operations

- modify [analogCodecLoopSet, loopTime];
- get [ePDHCTPId, supportedByObjectList, upstreamConnectivityPointer, downstreamConnectivityPointer, loopState, loopTime].

#### Notifications

- objectCreation is issued when the instance is created;

- objectDeletion is issued when the instance is deleted;
- attributeValueChange is issued if any of the following attributes change in value:  
analogCodecLoopSet, loopTime.

#### 7.3.2.3.18 e00WBtCTP (wide band tributary CTP)

##### Behaviour

An instance of this object class originates and terminates a wide band link connection. It represents the wide band tributary CTP on a WBaF. It is used for interconnecting the tributary wide band physical trail with the wide band interface of the e00WBCTP on an e0G722TTP at reference point N. This wide band tributary connection point object class is derived from the *ePDHCTPBidirectional* defined in the ETS 300 371 [29]. This managed object is automatically instantiated when the superior managed object (aF) is instantiated.

##### Attributes

- ePDHCTPId: Logical identification of the TP (value = 1);
- supportedByObjectList: The value of the supportedByObjectList attribute points to the *equipment* (transmission board) and *software* objects which implement the TP;
- upstreamConnectivityPointer: This has the value NULL set at instantiation;
- downstreamConnectivityPointer: This has the value NULL set at instantiation.

##### Operations

- get [ePDHCTPId, supportedByObjectList, upstreamConnectivityPointer, downstreamConnectivityPointer]

##### Notifications

- objectCreation is issued when the instance is created;
- objectDeletion is issued when the instance is deleted.

#### 7.3.2.3.19 sigtCTP (tributary signalling connection point)

##### Behaviour

An instance of this object class originates and terminates an access signalling link connection related to a 64 kbit/s TP. It represents the tributary signalling CTP on a sigaF. It is used for interconnecting the tributary signalling channels (signals at reference point N) with the signalling channels of the sigCTP on a castTP. This managed object is automatically instantiated when the superior managed object (aF) is instantiated.

##### Attributes

- sigCTPId: Logical identification of the TP;
- supportedByObjectList: The value of the supportedByObjectList attribute points to the *equipment* (transmission board) and *software* objects which implement the TP;
- upstreamConnectivityPointer: This has the value NULL set at instantiation;
- downstreamConnectivityPointer: This has the value NULL set at instantiation.

### Operations

- modify [administrativeState];
- get [sigCTPId, supportedByObjectList, upstreamConnectivityPointer, downstreamConnectivityPointer].

### Notifications

- objectCreation is issued when the instance is created;
- objectDeletion is issued when the instance is deleted.

#### 7.3.2.3.20 sigCTP (signalling connection point)

### Behaviour

An instance of this object class originates and terminates a CAS signalling link connection related to a 64 kbit/s link connection. It represents the signalling CTP on a sigTTP. It is used for interconnecting the signalling channels (signals at reference point N) with the signalling channels of the sigtCTP on the physical interface side. This signalling connection point object class is derived from the *casCTPBidirectional* defined in the ETS 300 371 [29]. This managed object is automatically instantiated when the superior managed object (aF) is instantiated.

### Attributes

- sigCTPId: Logical identification of the TP;
- supportedByObjectList: The value of the supportedByObjectList attribute points to the *equipment* (transmission board) and *software* objects which implement the TP;
- upstreamConnectivityPointer: This has the value NULL set at instantiation;
- downstreamConnectivityPointer: This has the value NULL set at instantiation.

### Operations

- get [sigCTPId, supportedByObjectList, upstreamConnectivityPointer, downstreamConnectivityPointer, supportedByObjectList].

### Notifications

- objectCreation is issued when the instance is created;
- objectDeletion is issued when the instance is deleted.

#### 7.3.2.3.21 casTTP (TSA signalling functional block)

### Behaviour

This object class corresponds to the PI functional block located between reference points O and N of the functional diagram shown in figure 1 of ETS 300 461-1 [31] (part 1 of this ETS). This CAS TTP object class terminates the CAS signalling path. It is derived from the *casTTPBidirectional object class* defined in ETS 300 371 [29]. This object includes the functions of a respective CTP (*castCTP*), e.g. AIS monitoring.

### Attributes

- casTTPId: Logical identification of the TP (value = 1);
- supportedByObjectList: The value of the supportedByObjectList attribute points to the *equipment* (transmission board) and *software* objects which implement the TP;

- alarmSeverityAssignmentProfilePointer: The value of this attribute points to the *alarmSeverityAssignmentProfile* object which identifies the alarm severity assignment profile related to this TP. If this attribute is not present, default severities are used;
- states of the signalling termination (ITU-T Recommendation X.731 [24]):
  - administrativeState (locked, unlocked): When the value is locked, the functions of the TP are administratively disabled, i.e. the TP does not process the signal nor detect failure of the signal. The administrativeState has no effect on the operationalState;
  - operationalState (enabled, disabled): The operational state is disabled if a SignallingConditionError (SIGCE) is detected or if one of the objects pointed to by the attribute supportedByObjectList is in the operationalState disabled;
  - alarmStatus: has the value representing the severity of the most severe alarm currently detected by the object.
- upstreamConnectivityPointer: This has the value NULL set at instantiation;
- downstreamConnectivityPointer: This has the value NULL set at instantiation;
- signallingProtocol: The value of this attribute selects or indicates the signalling protocol type used (NULL, string1 to stringn). The type value may be a string. NULL indicates that the used signalling bits are passed through transparently;
- signallingMode: The value of this attribute selects the signalling mode. Signalling modes may be supported in some signalling applications. For signallingProtocol (NULL) the signalling mode is set to NULL;
- sigBitUse (zero, one, CAS/CAC, G762processing) (note 2): This attribute controls usage of signalling bit a towards reference point M. The default not in use value is (zero) (note 1);
- sigBitbUse (zero, one, CAS/CAC): This attribute controls usage of signalling bit b towards reference point M. The default not in use value is (one) (note 1);
- sigBitcUse (zero, one, CAS/CAC, G762processing) (note 2): This attribute controls usage of signalling bit c towards reference point M. The default not in use value is (zero) (note 1);
- sigBitdUse (zero, one, CAS/CAC): This attribute controls usage of signalling bit d towards reference point M. The default not in use value is (one) (note 1);
- casFaultValue (NULL, 1H to FH): Signalling code towards the interface under fault conditions. The signalling code from reference point N towards reference point M is substituted by the casFaultValue under fault conditions. The casFaultValue is inserted before insertion of sigxBitUsage settings. NULL indicates no action in fault conditions;
- signalValues: The value of this attribute indicates the actual state of CAS signalling bits. Each signalling bit (a, b, c, d) in the Tx and Rx direction at reference point M but without CCITT Recommendation G762 [5] coding can take 4 states (ON, OFF, toggling).

#### Conditional attributes

- casSuspendValue (NULL, 0H to FH): Signalling code value towards reference point M, when suspending connection functionality by setting administrativeState to "Locked". This setting is supported only for signallingProtocol(NULL). The casSuspendValue is inserted before the sigBitxValues;
- sigFaultValue (NULL, 0H to FH): Signalling code value towards the local interface, reference point N, under fault conditions. This setting is supported only for signallingProtocol(NULL). The sigFaultValue is inserted before the sigChxValues;



- sigSuspendValue (NULL, 0H to FH): Signalling code value towards the local interface, reference point N, when suspending connection functionality by setting administrativeState to "Locked". This setting is supported only for signallingProtocol(NULL). The sigSuspendValue is inserted before the sigChxValues.

#### Conditional attributes (EM signalling only)

- sigChaUse (zero, one, CAS/CAC): This attribute controls usage of signalling channel a towards reference point N. The default not in use value is (zero);
- sigChbUse (zero, one, CAS/CAC): This attribute controls usage of signalling channel b towards reference point N. The default not in use value is (one);
- sigChcUse (zero, one, CAS/CAC): This attribute controls usage of signalling channel c towards reference point N. The default not in use value is (zero);
- sigChdUse (zero, one, CAS/CAC): This attribute controls usage of signalling channel d towards reference point N. The default not in use value is (one).

NOTE 1: In order not to disturb multiframe TS16 alignment the adcd bits shall not take the value 0H (all ones).

NOTE 2: In conjunction with ADPCM VF coding, processing of signalling bits a and b in accordance with CCITT Recommendation G.762 [5] is recommended. This assures that value 0H can occur only sporadically.

#### Operations

- modify [alarmSeverityAssignmentProfile-Pointer, administrativeState, signallingProtocol, signallingMode, sigBitaUse, sigBitbUse, sigBitcUse, sigBitdUse, casFaultValue, sigChaUse, sigChbUse, sigChcUse, sigChdUse, sigFaultValue, casSuspendValue, sigSuspendValue];
- get [sigTTPId, supportedByObjectList, alarmSeverityAssignmentProfile-Pointer, administrativeState, operationalState, alarmStatus, upstream-ConnectivityPointer, downstreamConnectivityPointer, crossConnection-ObjectPointer, characteristicInformation, signallingProtocol, signallingMode, sigBitaUse, sigBitbUse, sigBitcUse, sigBitdUse, casFault-Value, sigChaUse, sigChbUse, sigChcUse, sigChdUse, sigFaultValue, signal-Values, casSuspendValue, sigSuspendValue].

#### Notifications

- objectCreation is issued when the instance is created;
- objectDeletion is issued when the instance is deleted;
- stateChange: A stateChange Notification is issued when the operationalState change in value;
- Alarm Notification: A communicationsAlarm notification shall be issued if a SIGCE is detected ;
- attributeValueChange is issued if any of the following attributes change in value: alarmStatus, alarmSeverityAssignmentProfilePointer, administrative-State, signalling-protocol, signallingMode, sigBitaUse, sigBitbUse, sigBitcUse, sigBitdUse, casFaultValue, sigChaUse, sigChbUse, sigChcUse, sigChdUse, sigFaultValue;
- signallingFault: A signallingFault Notification may be issued when an inconsistent condition is detected by the signalling processing function.

### 7.3.2.4 Cross-connection fragment

#### 7.3.2.4.1 fmFabric (XC functional block)

##### Behaviour

The *fmFabric* object class represents the XC functional block, the optional CASXC and SF functional blocks, and the MCF functional block of the functional diagram shown in figure 1 of ETS 300 461-1 [31] (part 1 of this ETS).

Three instances of *fmFabric* may be instantiated depending on the characteristic information to be cross-connected.

A first instance of *fmFabric* is mainly in charge of the establishment and release of point-to-point cross-connections for 64 kbit/s and N x 64 kbit/s signals.

It also manages the assignment of N 64 kbit/s CTP (*e0CTP*) to groups of termination points (*e0gtp*) that represent N x 64 kbit/s signals.

If CAS is associated with the 64 or N x 64 kbit/s signal, this instance of *fabric* is able to transparently manage the establishment and release of the CAS cross-connection at the same time as the 64 or N x 64 kbit/s cross-connection. The CAS cross-connection is only possible if a *casCTP* is associated with the TP of the aggregate side and a *castCTP* or a *sigCTP* is associated with the TP of the tributary side.

It also transparently manages the assignment of N CAS connection termination points (*casCTP*) to a group of termination points (*casgtp*) at the same time as the assignment of the N *e0CTP* to the *e0gtp*.

A second instance of *fmFabric* is in charge of the establishment and release of cross-connections for management signals.

A third instance of *fmFabric* is in charge of the establishment and release of cross-connections for 2 048 kbit/s signals.

The *fmFabric* object class is a closely specialized *fabric* object class defined in CCITT Recommendation M.3100 [15]. The instances of *fmFabric* are automatically created at the initialization of the FM.

##### Attributes

- *fabricId*: Logical identification of a *fmFabric* object instance. This identification shall be unique for a FM;
- *supportedByObjectList*: The value of the *supportedByObjectList* attribute points to the *fmEquipment* (e.g. matrix board) and *fmSoftware* objects which implement this instance of *fmFabric*;
- states of the port (ITU-T Recommendation X.731 [24]):
  - *administrativeState* (locked, unlocked): When the value is locked, the functions of this *fmFabric* instance are administratively disabled, i.e. no action will be accepted to set-up or remove cross-connections neither to add/remove TPs to/from a GTP. The *administrativeState* has no effect on the *operationalState*;
  - *operationalState* (enabled, disabled): The operational state is enabled if the Fabric is fully or partially operational (partially operational is indicated by the *availabilityStatus* attribute). The operational state is disabled if the Fabric is fully disabled. When the operational state is disabled no action can be performed by Fabric;
  - *availabilityStatus* (degraded, normal): The *availabilityStatus* is degraded if at least one of the objects pointed to by the attribute *supportedByObjectList* is in the *operationalState* disabled but not all of them. The Fabric remains available for service (i.e. its *operationalState* is enabled while it is degraded).

## Operations

- connect [ ];
- disconnect [ ];
- addTpsToGTP [ ];
- removeTpsFromGTP [ ];
- modify [administrativeState];
- get [fabricId, supportedByObjectList, administrativeState, operationalState, availabilityStatus].

## Notifications

- State Change Notification: A stateChange notification may be issued in case of operationalState change or availabilityStatus change.

### 7.3.2.4.2 e0CrossConnection

#### Behaviour

The *e0CrossConnection* object class represents an assignment relationship between TPs or GTP objects at 64 kbit/s level.

A 64 or N x 64 kbit/s cross-connection is the result of a connect action on the correct instance of Fabric. If CAS is associated with the TPs to be cross-connected, a CAS cross-connection will result from the same connect action used for establishing the N x 64 kbit/s cross-connection. This CAS cross-connection is contained (named) by the 64 or N x 64 kbit/s cross-connection.

The 64 or N x 64 kbit/s cross-connection is a point-to-point bi-directional cross-connection. Other types of cross-connections are out of the scope of this ETS (special functions are not described in part 1).

The *e0CrossConnection* object class is a closely specialized *crossConnection* object class defined in CCITT Recommendation M.3100 [15].

#### Attributes

- crossConnectionId: Logical identification number of a cross-connection. This identification shall be unique for a given Fabric;
- fromTermination: The value of this attribute points to the first TP or GTP implicated in the cross-connection;
- toTermination: The value of this attribute points to the second TP or GTP implicated in the cross-connection;
- states of the port (ITU-T Recommendation X.731 [24]):
  - administrativeState (locked, unlocked): When the value is locked, no traffic is allowed to pass through the cross-connection;
  - operationalState (enabled, disabled): When disabled, the cross-connection is incapable of performing its function, i.e. make traffic pass from one TP or GTP to another one;
- fromTerminationLoopback (ON, OFF): This attribute allows the setup of a loopback on the TP or GTP pointed to by the fromTermination attribute;
- toTerminationLoopback (ON, OFF): This attribute allows the setup of a loopback on the TP or GTP pointed to by the toTermination attribute.

### Operations

- modify [administrativeState];
- get [crossConnectionId, fromTermination, toTermination, administrativeState, operationalState].

### Notifications

- State Change Notification: A stateChange Notification may be issued in case of operationalState change.

#### 7.3.2.4.3 casCrossConnection

### Behaviour

The *casCrossConnection* object class represents an assignment relationship between CAS CTP or CAS GTP objects.

A CAS cross-connection results from the same connect action used for establishing a N x 64 kbit/s cross-connection.

The CAS cross-connection is contained (named) by the N x 64 kbit/s cross-connection.

The CAS Cross-Connection is a point-to-point bi-directional cross-connection. Other types of cross-connections are out of the scope of this ETS (special functions are not described in part 1).

The *casCrossConnection* object class is a closely specialized *crossConnection* object class defined in CCITT Recommendation M.3100 [15].

### Attributes

- crossConnectionId: Logical Identification number of a cross-connection. This identification shall be unique for a given Fabric;
- fromTermination: The value of this attribute points to the first TP or GTP implicated in the cross-connection;
- toTermination: The value of this attribute points to the second TP or GTP implicated in the cross-connection;
- states of the port (ITU-T Recommendation X.731 [24]):
  - administrativeState (locked, unlocked): When the value is locked, no traffic is allowed to pass through the cross-connection;
  - operationalState (enabled, disabled): When disabled, the cross-connection is incapable of performing its function, i.e. make traffic pass from one TP or GTP to another.

### Operations

- modify [administrativeState];
- get [crossConnectionId, fromTermination, toTermination, administrativeState, operationalState].

### Notifications

- State Change Notification: A stateChange notification may be issued in case of operationalState change.

#### 7.3.2.4.4 e1CrossConnection

##### Behaviour

The *e1CrossConnection* object class represents an assignment relationship between TPs or GTP objects at 2 Mbit/s level.

A 2 Mbit/s cross-connection is the result of a connect action on the correct instance of Fabric. The 2 Mbit/s cross-connection is a point-to-point bi-directional cross-connection.

The *e1CrossConnection* object class is a closely specialized *crossConnection* object class defined in CCITT Recommendation M.3100 [15].

##### Attributes

- crossConnectionId: Logical Identification number of a cross-connection. This identification shall be unique for a given Fabric;
- fromTermination: The value of this attribute points to the first TP or GTP implicated in the cross-connection;
- toTermination: The value of this attribute points to the second TP or GTP implicated in the cross-connection;
- states of the port (ITU-T Recommendation X.731 [24]):
  - administrativeState (locked, unlocked): When the value is locked, no traffic is allowed to pass through the cross-connection;
  - operationalState (enabled, disabled): When disabled, the cross-connection is incapable of performing its function, i.e. make traffic pass from one TP or GTP to another one.

##### Operations

- modify [administrativeState];
- get [crossConnectionId, fromTermination, toTermination, administrativeState, operationalState].

##### Notifications

- State Change Notification: A stateChange Notification may be issued in case of operationalState change.

#### 7.3.2.4.5 mngtCrossConnection

##### Behaviour

The *mngtCrossConnection* object class represents an assignment relationship between TPs objects for management of the FM.

A Management cross-connection is the result of a connect action on the correct instance of Fabric. The management cross-connection is a point-to-point bi-directional cross-connection.

The *mngtCrossConnection* object class is a closely specialized *crossConnection* object class defined in CCITT Recommendation M.3100 [15].

##### Attributes

- crossConnectionId: Logical Identification number of a cross-connection. This identification shall be unique for a given Fabric;
- fromTermination: The value of this attribute points to the first TP implicated in the cross-connection;

- toTermination: The value of this attribute points to the second TP implicated in the cross-connection;
- states of the port (ITU-T Recommendation X.731 [24]):
  - administrativeState (locked, unlocked): When the value is locked, no traffic is allowed to pass through the cross-connection;
  - operationalState (enabled, disabled): When disabled, the cross-connection is incapable of performing its function, i.e. make traffic pass from one TP to another.

### Operations

- modify [administrativeState];
- get [crossConnectionId, fromTermination, toTermination, administrativeState, operationalState].

### Notifications

- state change notification: A stateChange notification may be issued in case of operationalState change.

#### 7.3.2.4.6 e0gtp (64 kbit/s group termination point)

The *e0gtp* object class represents an assignment relationship between 64 kbit/s CTPs (*e0CTP*).

If a CAS is associated with the TPs to be grouped, a CAS GTP will result from the same addTpsToGtp action used for establishing the 64 kbit/s GTP. This CAS GTP is contained (named) by the 64 kbit/s GTP.

The *e0gtp* object class is a closely specialized *gtp* object class defined in CCITT Recommendation M.3100 [15].

### Attributes

- gtpId: Logical Identification of the GTP. This identification shall be unique for a given Fabric;
- crossConnectionObjectPointer: The value of this attribute points to a *crossConnection* object;
- tpsInGtpList: Each value of this list points to the TPs that are grouped in the GTP.

### Operations

- get [gtpId, crossConnectionObjectPointer, tpsInGtpList].

#### 7.3.2.4.7 casgtp (64 kbit/s group termination point)

The *casgtp* object class represents an assignment relationship between CAS CTPs (*casCTP*).

A CAS GTP results from the same addTpsToGTP action used for establishing a 64 kbit/s GTP.

The CAS GTP is contained (named) by the 64 kbit/s GTP.

The *casgtp* object class is a close specialization of the *gtp* object class defined in CCITT Recommendation M.3100 [15].

### Attributes

- gtpId: Logical Identification of the GTP. This identification shall be unique for a given Fabric;
- crossConnectionObjectPointer: The value of this attribute points to a *crossConnection* object;
- tpsInGtpList: Each value of this list points to the TPs that are grouped in the GTP.

### Operations

- get [gtpId, crossConnectionObjectPointer, tpsInGtpList].

### 7.3.2.5 Synchronization fragment

#### 7.3.2.5.1 fmTimingGenerator (MTS functional block)

### Behaviour

The *fmTimingGenerator* object class represents the MTS functional block of the functional diagram shown in figure 1 of ETS 300 461-1 [31] (part 1 of this ETS).

For the selection of a the timing source, a 1:n protection mechanism is used by the way of a *tsProtectionGroup* and *tsProtectionUnits*.

The *fmTimingGenerator* object class is a closely specialized *timingGenerator* object class defined in ETS 300 304 [28].

Only one instance of *fmTimingGenerator* exists. This instance of *fmTimingGenerator* is automatically created at the initialization of the FM.

### Attributes

- timingGeneratorId: Logical identification of the *fmTimingGenerator* object instance. This identification shall be unique for a FM;
- currentTimingSourcePointer: The value of this attribute points to the timing source currently in use. A value of NULL of this attribute indicates the use of the internal oscillator;
- supportedByObjectList: The value of the supportedByObjectList attribute points to the *fmEquipment* and *fmSoftware* objects which implement this instance of *fmTimingGenerator*.
- states of the timing generator (ITU-T Recommendation X.731 [24]):
  - operationalState (enabled, disabled): The operational state is disabled if one of the objects pointed to by the attribute supportedByObjectList is in the operationalState disabled. The operationalState is not affected if a Loss of Synchronization Reference (LSR) is detected.

### Operations

- get [timingGeneratorId, currentTimingSourcePointer, supportedByObjectList, operationalState].

### Notifications

- alarm notification. An equipmentAlarm notification shall be issued if a LSR is detected. The probableCause parameter of the notification shall indicate LSR. The default value of the perceivedSeverity associated to this probableCause in the ASAP is critical;
- state change notification: A stateChange notification may be issued in case of operationalState change;
- attribute value change notification: An attributeValueChange notification is issued if the following attribute changes in value: currentTimingSourcePointer.

### 7.3.2.5.2 pPI1G703ITSTTP (TIPI functional block)

#### Behaviour

This object class corresponds to the TIPI functional block of the functional diagram shown in figure 1 of ETS 300 461-1 [31] (part 1 of this ETS). It represents the external 2 MHz input interface. It terminates a 2 MHz signal.

The definition of this 2 048 kbit/s CCITT Recommendation G.703 [1] Input Timing Source Trail Termination Point (ITSTTP) object class is close to the *timingPhysicalTerminationSink* object class defined in ETS 300 304 [28].

This managed object may be automatically instantiated when the supporting managed object is instantiated, according to the make-up and mode of operation of the FM.

#### Attributes

- iTSTTPId: Logical identification of the ITSTTP. This identification shall be unique for a FM;
- accessPort: The value of this attribute has to unambiguously indicate the associated access port;
- supportedByObjectList: The value of the supportedByObjectList attribute points to the *fmEquipment* hardware block and *fmSoftware* objects which implement the ITSTTP;
- alarmSeverityAssignmentProfilePointer: The value of this attribute points to the *alarmSeverityAssignmentProfile* object which identifies the alarm severity assignment profile related to this ITSTTP. If this attribute is not present, the attribute alarmSeverityAssignmentProfilePointer of the containing object is used;
- States of the ITSTTP (ITU-T Recommendation X.731 [24]):
  - administrativeState (locked, unlocked): When the value is locked, the functions of the ITSTTP are administratively disabled, i.e. the ITSTTP does not process the signal nor detect failure of the signal. The administrativeState has no effect on the operationalState;
  - operationalState (enabled, disabled): The operational state is disabled if a LOS is detected or if one of the objects pointed to by the attribute supportedByObjectList is in the operationalState disabled;
  - alarmStatus: When an alarm is present on the ITSTTP, the value of this attribute indicates the severity of this alarm.
- impedance (75, 120): This attribute indicates the current impedance 75 W coaxial pair option, or a 120 W symmetrical pair option and, if provided, permits to select this impedance.

#### Actions

- Create [iTSTTPId, accessPort, supportedByObjectList, alarmSeverityAssignmentProfilePointer, administrativeState, operationalState, alarmStatus, impedance] (no need if automatic creation);
- Delete (no need if automatic deletion);
- modify [alarmSeverityAssignmentProfilePointer, administrativeState, impedance (if provided)];
- get [iTSTTPId, accessPort, supportedByObjectList, alarmSeverityAssignmentProfilePointer, administrativeState, operationalState, alarmStatus, impedance].



## Notifications

- ObjectCreation;
- Object Deletion;
- Alarm Notification (refers to CCITT Recommendation G.703 [1] alarms): A communicationsAlarm notification shall be issued if a LOS is detected. The probableCause parameter of the notification shall indicate LOS;
- State Change Notification: A stateChange notification may be issued in case of operationalState change or alarmStatus change;
- Attribute Value Change Notification: An attributeValueChange notification is issued if any of the following attributes changes in value: alarmSeverityAssignmentProfilePointer.

### 7.3.2.5.3 pPI1G703OTSTTP (TOPI functional block)

#### Behaviour

This object class corresponds to the optional TOPI functional block of the functional diagram shown in figure 1 of ETS 300 461-1 [31] (part 1 of this ETS). It represents the external 2 MHz output interface. It originates the 2 MHz signal issued from the timing generator of the FM.

The definition of this 2 048 kbit/s CCITT Recommendation G.703 [1] Output Timing Source Trail Termination Point (OTSTTP) object class is close to the *timingPhysicalTerminationSource* object class defined in ETS 300 304 [28].

Only one instance of *pPI1G703OTSTTP* exists. This managed object may be automatically instantiated when the supporting managed object is instantiated, depending on the make-up and operational mode of the FM.

#### Attributes

- oTSTTPId: Logical identification of the OTSTTP. This identification shall be unique for a FM;
- accessPort: The value of this attribute has to unambiguously indicate the associated access port;
- supportedByObjectList: The value of the supportedByObjectList attribute points to the *fmEquipment* and *fmSoftware* objects which implement the OTSTTP;
- outputTimingSourcePointer: The value of this attribute points to the *fmTimingGenerator*;
- states of the output timing source termination (ITU-T Recommendation X.731 [24]):
  - operationalState (enabled, disabled): The operational state is disabled if one of the objects pointed to by the attribute supportedByObjectList is in the operationalState disabled.
- impedance (75, 120): This attribute indicates the current impedance 75 W coaxial pair option, or a 120 W symmetrical pair option and, if provided, permits to select this impedance.

#### Actions

- create [oTSTTPId, accessPort, supportedByObjectList, outputTimingSourcePointer, operationalState, impedance] (no need if automatic creation);
- delete (no need if automatic deletion);
- modify [impedance (if provided)];
- get [oTSTTPId, accessPort, supportedByObjectList, outputTimingSourcePointer, operationalState, impedance].

## Notifications

- object creation;
- object deletion;
- state change notification: A stateChange notification may be issued in case of operationalState change.

### 7.3.2.5.4 tSProtectionGroup (MTS functional block)

#### Behaviour

The *tSProtectionGroup* object class represents the protected or protecting timing source units of the FM.

This timing source protectionGroup object instance contains two or more timing source protectionUnit objects for defining a protection switching relationship where one or more standby entities provide protection for the current timing source (1:n protection mechanism).

The *tSProtectionGroup* object class is a specialized *protectionGroup* object class defined in ETS 300 304 [28]. This managed object is automatically instantiated.

#### Attributes

- protectionGroupId: Logical identification of a *protectionGroup* object instance. This identification shall be unique for a FM;
- protectionGroupType (1+1, m:n): This attribute specifies whether the protection scheme used is a 1+1 or m:n (m:n includes the cases where m=1 and/or n=1);
- revertible (true, false): This attribute indicates whether the protection scheme is revertible or not. If the value is true, the traffic is returned to the protected protectionUnit instance that initiated the switch after the fault clear and the waitToRestoreTime interval (if any) has expired. If the value is false, then after the fault has cleared, traffic does not revert to the protectionUnit that initiated the switch;
- supportedByObjectList: The value of the supportedByObjectList attribute points to the *fmEquipment* and *fmSoftware* objects which implement the TP;
- waitToRestoreTime: This attribute specifies the amount of time, in seconds, to wait after a fault clear before restoring traffic to the protected protectionUnit that initiated the switching;
- states of the timing source protection group (ITU-T Recommendation X.731 [24]):
  - operationalState (enabled, disabled): The operational state reflects the switch capabilities of the protection scheme. (i.e. it becomes disabled when the NE has detected that it can no longer perform switch operations (automatic or manual)).

#### Operations

- modify [protectionGroupType, revertible, waitToRestoreTime];
- get [protectionGroupId, protectionGroupType, revertible, supportedByObjectList, waitToRestoreTime, operationalState];
- invokeProtection: This action can be used to request a lockout, a forced switch, or a manual switch on one or more protectionUnit instances contained in the protectionGroup object;
- releaseProtection: This action can be used to release a lockout, a forced switch, or a manual switch on one or more protectionUnit instances contained in the protectionGroup object.

## Notifications

- state change notification: A stateChange notification may be issued in case of operationalState change;
- protectionSwitchReporting: This notification is emitted from the protectionGroup object to report any protection switch events, such as protection switching, protection release, lockout or release of lockout.

#### 7.3.2.5.5 tSProtectionUnit (MTS functional block)

##### Behaviour

The *tSProtectionUnit* object class represents a relationship between a timing source and the timing generator of the FM.

The *tSProtectionUnit* object class is a specialized *syncProtectionUnit* object class defined in ETS 300 304 [28]. This managed object may be automatically instantiated according to the make-up and mode of operation of the equipment.

##### Attributes

- protectionUnitId: Logical identification of a *protectionUnit* object instance. This identification shall be unique for a timing source protection group;
- priority (1, n): This attribute specifies the priority of the service carried on the resource associated to the protected protectionUnit instance. The value 1 indicates the highest priority;
- syncProtectionStatus (No request, Force Switch Complete to Protecting Unit, Automatic Switch Complete to Protecting Unit, Protecting Unit Failed, Protecting Unit Locked Out): This attribute indicates the status of the protection switch:
  - no request: No request is present on the protecting unit;
  - force switch Complete to Protecting Unit: A force switch has been completed to this protecting unit;
  - automatic switch complete to protecting unit: An Automatic which has been completed to this protecting unit;
  - protecting unit failed: The protecting unit has a failure condition present;
  - protecting unit locked out: The protecting Unit has been locked out.
- protecting (true, false): This attribute specifies the type of the protectionUnit. A value of true indicates that the protectionUnit is a protecting unit. A value of false indicates that the protectionUnit is a protected unit. A change in the value of this attributes shall cause an attributeValueChange notification;
- reliableResourcePointer: The value of this attribute points to the reliable resource (*fmTimingGenerator*) that is associated to the protectionUnit instance or is NULL;
- unreliableResourcePointer: The value of this attribute points to the unreliable resource that is associated to the protectionUnit instance.

##### Operations

- create [protectionUnitId, priority, syncProtectionStatus, protecting, reliableResourcePointer, unreliableResourcePointer];
- delete;
- modify [priority];

- get [protectionUnitId, priority, syncProtectionStatus, protecting, reliableResourcePointer, unreliableResourcePointer].

### Notifications

- attribute value change notification: An attributeValueChange notification is issued if any of the following attributes changes in value: syncProtectionStatus, protecting.

### 7.3.2.6 Optional protection fragment

#### 7.3.2.6.1 IPProtectionGroup (LPPSW functional block)

### Behaviour

The *IPProtectionGroup* object class represents protected or protecting low order paths in the FM.

This low order path protectionGroup object instance contains two or more low order path protectionUnit objects for defining a protection switching relationship where one or more standby entities provide protection for the current Path (1+1 or 1:n protection mechanism).

The *IPProtectionGroup* object class is a specialization of the *protectionGroup* object class defined in ETS 300 304 [28].

### Attributes

- protectionGroupId: Logical identification of a *protectionGroup* object instance. This identification shall be unique for a FM;
- protectionGroupType (1+1, m:n): This attribute specifies whether the protection scheme used is a 1+1 or m:n. (m:n includes the cases where m=1 and/or n=1);
- revertible (true, false): This attribute indicates whether the protection scheme is revertible or not. If the value is true, the traffic is returned to the protected protectionUnit instance that initiated the switch after the fault clear and the waitToRestoreTime interval (if any) has expired. If the value is false, then after the fault has cleared, traffic does not revert to the protectionUnit that initiated the switch;
- supportedByObjectList: The value of the supportedByObjectList attribute points to the *fmEquipment* and *fmSoftware* objects which implement the TP;
- waitToRestoreTime: This attribute specifies the amount of time, in seconds, to wait after a fault clear before restoring traffic to the protected protectionUnit that initiated the switching;
- states of the protection switch (ITU-T Recommendation X.731 [24]):
  - operationalState (enabled, disabled): The operational state indicates the ability of the protection switch to perform the protection switching function.

### Operations

- create [protectionGroupId, protectionGroupType, revertible, supportedByObjectList, waitToRestoreTime, operationalState];
- delete;
- modify [protectionGroupType, revertible, waitToRestoreTime];
- get [protectionGroupId, protectionGroupType, revertible, supportedByObjectList, waitToRestoreTime, operationalState];
- invokeProtection: This action can be used to request a lockout, a forced switch, or a manual switch on one or more protectionUnit instances contained in the protectionGroup object;

- releaseProtection: This action can be used to release a lockout, a forced switch, or a manual switch on one or more protectionUnit instances contained in the protectionGroup object.

#### Notifications

- state change notification: A stateChange notification may be issued in case of operationalState change;
- protectionSwitchReporting: This notification is emitted from the protectionGroup object to report any protection switch events, such as protection switching, protection release, lockout or release of lockout.

### 7.3.2.6.2 IPProtectionUnit (LPPSW functional block)

#### Behaviour

The *IPProtectionUnit* object class represents the protected or protecting low order path in the FM.

The *IPProtectionUnit* object class is a specialized *protectionUnit* object class defined in ETS 300 304 [28]. This managed object may be automatically instantiated according to the make-up and mode of operation of the equipment.

#### Attributes

- protectionUnitId: Logical identification of a *protectionUnit* object instance. This identification shall be unique for a timing source protection group;
- priority (1, n): This attribute specifies the priority of the service carried on the resource associated with the protected protectionUnit instance. The value 1 indicates the highest priority;
- protectionStatus: see ITU-T Recommendation G.774.03 [6] and ETS 300 304 [28];
- protecting (true, false): This attribute specifies the type of the protectionUnit. A value of True indicates that the protectionUnit is a protecting unit. A value of false indicates that the protectionUnit is a protected unit. A change in the value of this attributes shall cause an attributeValueChange notification;
- reliableResourcePointer: The value of this attribute points to the reliable resources that are associated to the protectionUnit instance;
- unreliableResourcePointer: The value of this attribute points to the unreliable resources that are associated to the protectionUnit instance;

#### Operations

- create [protectionUnitId, priority, protectionStatus, protecting, reliableResourcePointer, unreliableResourcePointer];
- delete;
- modify [priority];
- get [protectionUnitId, priority, protectionStatus, protecting, reliableResourcePointer, unreliableResourcePointer].

#### Notifications

- Attribute Value Change Notification: An attributeValueChange notification is issued if any of the following attributes changes in value: syncProtectionStatus, protecting.

### 7.3.2.6.3 ISPProtectionGroup (LSPSW functional block)

#### Behaviour

The *ISProtectionGroup* object class represents protected or protecting low order sections in the FM.

This low order section protectionGroup object instance contains two low order section protectionUnit objects for defining a protection switching relationship where one standby entity provides protection for the current section (1+1 protection mechanism).

The *ISProtectionGroup* object class is a specialized *protectionGroup* object class defined in ETS 300 304 [28].

#### Attributes

- protectionGroupId: Logical identification of a *protectionGroup* object instance. This identification shall be unique for a FM;
- protectionGroupType (1+1, m:n): This attribute takes the value 1+1;
- revertible (true, false): This attribute indicates whether the protection scheme is revertible or not. If the value is true, the traffic is returned to the protected protectionUnit instance that initiated the switch after the fault clear and the waitToRestoreTime interval (if any) has expired. If the value is false, then after the fault has cleared, traffic does not revert to the protectionUnit that initiated the switch;
- supportedByObjectList: The value of the supportedByObjectList attribute points to the *fmEquipment* and *fmSoftware* objects which implement the TP;
- waitToRestoreTime: This attribute specifies the amount of time, in seconds, to wait after a fault clear before restoring traffic to the protected protectionUnit that initiated the switching;
- States of the protection switch (ITU-T Recommendation X.731 [24]):
  - operationalState (enabled, disabled): The operational state indicates the ability of the protection switch to perform the protection switching function.

#### Operations

- create [protectionGroupId, protectionGroupType, revertible, supportedByObjectList, waitToRestoreTime, operationalState];
- delete;
- modify [revertible, waitToRestoreTime];
- get [protectionGroupId, protectionGroupType, revertible, supportedByObjectList, waitToRestoreTime, operationalState];
- invokeProtection: This action can be used to request a lockout, a forced switch, or a manual switch on one or more protectionUnit instances contained in the protectionGroup object;
- releaseProtection: This action can be used to release a lockout, a forced switch, or a manual switch on one or more protectionUnit instances contained in the protectionGroup object.

#### Notifications

- state change notification: A stateChange notification may be issued in case of operationalState change;
- protectionSwitchReporting: This notification is emitted from the protectionGroup object to report any protection switch events, such as protection switching, protection release, lockout or release of lockout.

#### 7.3.2.6.4 ISProtectionUnit (LSPSW functional block)

##### Behaviour

The *ISProtectionUnit* object class represents the protected or protecting low order sections in the FM.

The *ISProtectionUnit* object class is a specialized *protectionUnit* object class defined in ETS 300 304 [28]. This managed object may be automatically instantiated according to the make-up and mode of operation of the equipment.

##### Attributes

- protectionUnitId: Logical identification of a *protectionUnit* object instance. This identification shall be unique for a timing source protection group;
- priority (1, n): This attribute specifies the priority of the service carried on the resource associated to the protected protectionUnit instance. The value 1 indicates the highest priority;
- protectionStatus: see ITU-T Recommendation G.774.03 [6] and ETS 300 304 [28];
- protecting (true, false): This attribute specifies the type of the protectionUnit. A value of true indicates that the protectionUnit is a protecting unit. A value of false indicates that the protectionUnit is a protected unit. A change in the value of these attributes shall cause an attributeValueChange notification;
- reliableResourcePointer: The value of this attribute points to the reliable resources that are associated to the protectionUnit instance;
- unreliableResourcePointer: The value of this attribute points to the unreliable resources that are associated to the protectionUnit instance.

##### Operations

- create [protectionUnitId, priority, protectionStatus, protecting, reliableResourcePointer, unreliableResourcePointer];
- delete;
- modify [priority];
- get [protectionUnitId, priority, protectionStatus, protecting, reliableResourcePointer, unreliableResourcePointer].

##### Notifications

- attribute value change notification: An attributeValueChange notification is issued if any of the following attributes changes in value: syncProtectionStatus, protecting.

#### 7.3.2.6.5 protectedTTP

##### Behaviour

The *protectedTTP* object class represents the protected resources in a protection system. An instance of this object class is pointed to by the reliableResourcePointer attribute in an instance of the protectionUnit object class (*ISProtectionUnit* or *IPPProtectionUnit*).

The unprotectedCTP is instantiated when a low order section protection switch function is present or a low order path protection switch function is present.

This unprotected CTP object class is a specialized *unprotectedCTPBidirectional* object class defined in the ETS 300 304 [28].

### Attributes

- `protectedTTPId`: Logical identification of the protected TTP;
- `crossConnectionObjectPointer`: The value of this attribute points to its associated `protectionUnit` object instance;
- `upstream/downstreamConnectivityPointers`: The values of these attributes point to either null or the associated unprotected CTP object instance; it indicates the actual signal flow, and when a signal is switched to another unit, these values are updated.

### Operations

- `get [protectedTTPId, crossConnectionObjectPointer, upstream/downstreamConnectivityPointers]`.

#### 7.3.2.6.6 `unprotectedCTP`

### Behaviour

The *unprotectedCTP* object class represents the unprotected resource in a protection system. An instance of this object class is pointed to by the `unreliableResourcePointer` attribute in an instance of the `protectionUnit` object class (*ISProtectionUnit* or *IPProtectionUnit*).

The `unprotectedCTP` is instantiated when a low order section protection switch function is present or a low order path protection switch function is present.

This unprotected CTP object class is a specialized *unprotectedCTPBidirectional* object class defined in the ETS 300 304 [28].

### Attributes

- `unprotectedCTPId`: Logical identification of the unprotected CTP;
- `crossConnectionObjectPointer`: The value of this attribute points to its associated `protectionUnit` object instance a *crossConnection* object.

### Operations

- `get [unprotectedCTPId, crossConnectionObjectPointer]`.



## History

| Document history |                |        |                          |
|------------------|----------------|--------|--------------------------|
| September 1995   | Public Enquiry | PE 93: | 1995-10-09 to 1996-02-02 |
| August 1996      | Vote           | V 108: | 1996-08-05 to 1996-09-27 |
| October 1996     | First Edition  |        |                          |
|                  |                |        |                          |
|                  |                |        |                          |