



**E**UROPEAN  
**T**ELECOMMUNICATION  
**S**TANDARD

**DRAFT**  
pr **ETS 300 461-1**

January 1995

---

Source: ETSI TC-TM

Reference: DE/TM-01013-1

ICS: 33.080

**Key words:** Interface, transmission, multiplexing

**Transmission and Multiplexing (TM);  
Flexible Multiplexer (FM) equipment  
Part 1: Core functions, 2 048 kbit/s aggregate interface  
functions, tributary interface functions and special functions**

**ETSI**

European Telecommunications Standards Institute

**ETSI Secretariat**

**Postal address:** F-06921 Sophia Antipolis CEDEX - FRANCE

**Office address:** 650 Route des Lucioles - Sophia Antipolis - Valbonne - FRANCE

**X.400:** c=fr, a=atlas, p=etsi, s=secretariat - **Internet:** secretariat@etsi.fr

Tel.: +33 92 94 42 00 - Fax: +33 93 65 47 16

---

**Copyright Notification:** No part may be reproduced except as authorized by written permission. The copyright and the foregoing restriction extend to reproduction in all media.

© European Telecommunications Standards Institute 1995. All rights reserved.



## Contents

Foreword .....	9
1 Scope .....	11
2 Normative references .....	11
3 Definitions .....	13
4 Symbols and abbreviations .....	13
5 Network reference configuration .....	14
6 Reference model and reference points .....	15
7 Core functions .....	18
7.1 Cross connection functions .....	18
7.2 Multiplexer Timing Source .....	19
7.3 Control functions .....	20
7.4 Timing interfaces at 2 048 kHz .....	20
7.5 Power supply interface .....	20
7.6 Configurable parameters .....	20
7.7 Test functions .....	20
8 Aggregate interfaces .....	20
8.1 Reference point G .....	21
8.2 2 048 kbit/s CCITT Recommendation G.703 aggregate interface .....	21
8.2.1 Physical Interface function .....	21
8.2.1.1 Physical interface .....	21
8.2.1.2 Signal processing .....	21
8.2.1.3 Performance .....	21
8.2.1.4 Control signals .....	21
8.2.1.5 Signal at reference point B (or G) .....	22
8.2.1.6 Mapping rules .....	22
8.2.1.7 Configurable parameters .....	22
8.2.1.8 Test functions .....	22
8.2.2 Lower order Section Protection Switch function .....	23
8.2.2.1 Signal at reference point B .....	23
8.2.2.2 Signal processing .....	23
8.2.2.3 Performance .....	23
8.2.2.4 Control signals .....	23
8.2.2.5 Signal at reference point G .....	23
8.2.2.6 Mapping rules .....	23
8.2.2.7 Configurable parameters .....	24
8.2.2.8 Test functions .....	24
8.3 Plesiochronous Lower order Path Termination function .....	24
8.3.1 Signal at reference point G .....	24
8.3.2 Signal processing .....	24
8.3.3 Performance .....	25
8.3.4 Control signals .....	25
8.3.5 Signal at reference point H (or J) .....	25
8.3.6 Mapping rules .....	25
8.3.7 Configurable parameters .....	25
8.3.8 Test functions .....	25
8.4 Lower order Path Protection Switch function .....	25
8.4.1 Signal at reference point H .....	25
8.4.2 Signal processing .....	26

	8.4.2.1	1+1 protection .....	26
	8.4.2.2	1 for n protection .....	26
8.4.3		Performance .....	27
8.4.4		Control signals .....	27
8.4.5		Signal at reference point J .....	27
8.4.6		Mapping rules .....	27
8.4.7		Configurable parameters .....	27
8.4.8		Test functions .....	27
9		Tributary interfaces .....	27
9.1		Analogue, 64 kbit/s coding interfaces .....	27
9.1.1		2-wire/4-wire voice band (3 400 Hz) interface .....	27
	9.1.1.1	Physical interface .....	28
	9.1.1.2	Coding .....	28
	9.1.1.3	Performance .....	28
	9.1.1.4	Signalling .....	28
	9.1.1.5	Signal at reference point M .....	28
	9.1.1.6	Cross connection rules .....	29
	9.1.1.7	Configurable parameters .....	29
	9.1.1.8	Test functions .....	29
9.1.2		2-wire/4-wire voice band (3 400 Hz) with d.c. signalling interface .....	29
	9.1.2.1	Physical interface .....	29
	9.1.2.2	Coding .....	29
	9.1.2.3	Performance .....	30
	9.1.2.4	Signalling .....	30
	9.1.2.5	Signal at reference point M .....	30
	9.1.2.6	Cross connection rules .....	30
	9.1.2.7	Configurable parameters .....	30
	9.1.2.8	Test functions .....	31
9.1.3		PSTN interface .....	31
9.1.4		Wide band (7 kHz) interface .....	31
	9.1.4.1	Physical interface .....	31
	9.1.4.2	Coding .....	31
	9.1.4.3	Performance .....	32
	9.1.4.4	Signalling .....	32
	9.1.4.5	Signal at reference point M .....	32
	9.1.4.6	Cross connection rules .....	32
	9.1.4.7	Configurable parameters .....	32
	9.1.4.8	Test functions .....	32
9.2		Synchronous data interfaces .....	33
9.2.1		CCITT Recommendation G.703/64 kbit/s Codirectional interface .....	33
	9.2.1.1	Physical interface .....	33
	9.2.1.2	Signal processing .....	33
	9.2.1.3	Performance .....	33
	9.2.1.4	Control signals .....	33
	9.2.1.5	Signal at reference point M .....	33
	9.2.1.6	Cross connection rules .....	33
	9.2.1.7	Configurable parameters .....	34
	9.2.1.8	Test functions .....	34
9.2.2		CCITT Recommendation X.24 interface .....	34
	9.2.2.1	Physical interface .....	34
	9.2.2.2	Signal processing .....	35
	9.2.2.3	Performance .....	35
	9.2.2.4	Control signals .....	35
	9.2.2.5	Signal at reference point M .....	35
	9.2.2.6	Cross connection rules .....	35
	9.2.2.7	Configurable parameters .....	36
	9.2.2.8	Test functions .....	36
9.2.3		CCITT Recommendation V.24 (V.10 and V.11) interface .....	36
	9.2.3.1	Physical interface .....	37
	9.2.3.2	Signal processing .....	38
	9.2.3.3	Performance .....	38
	9.2.3.4	Control signals .....	38

	9.2.3.5	Signal at reference point M.....	38
	9.2.3.6	Cross connection rules .....	38
	9.2.3.7	Configurable parameters .....	38
	9.2.3.8	Test functions .....	38
9.2.4		Integrated base band transmission system for data interfaces.....	39
	9.2.4.1	Physical interface.....	39
	9.2.4.2	Signal processing .....	39
	9.2.4.3	Performance .....	39
	9.2.4.4	Control signals .....	39
	9.2.4.5	Signal at reference point M.....	40
	9.2.4.6	Cross connection rules .....	40
	9.2.4.7	Configurable parameters .....	40
	9.2.4.8	Test functions .....	40
9.3		CCITT Recommendation G.704 formatted n x 64 kbit/s signal interface .....	40
	9.3.1	Physical interface .....	40
	9.3.2	Signal processing .....	40
	9.3.3	Performance.....	41
	9.3.4	Control signals.....	41
	9.3.5	Signal at reference point M .....	41
	9.3.6	Cross connection rules.....	41
	9.3.7	Configurable parameters.....	41
	9.3.8	Test functions .....	42
9.4		ISDN tributary interfaces.....	42
9.5		CCITT Recommendation G.703/2 048 kbit/s unstructured interface.....	43
	9.5.1	Physical interface .....	43
	9.5.2	Signal processing .....	43
	9.5.3	Performance.....	43
	9.5.4	Control signals.....	43
	9.5.5	Signal at reference point G.....	43
	9.5.6	Cross connection rule.....	43
	9.5.7	Configurable parameters.....	43
	9.5.8	Test functions .....	43
10		Defect or failure conditions and consequent actions.....	44
	10.1	Defect or failure conditions in the core functions and consequent actions at reference points J1 and M2.....	44
		10.1.1 Defect or failure conditions in the core functions .....	44
		10.1.1.1 Power supply failure .....	44
		10.1.1.2 Loss of synchronization references .....	44
		10.1.2 Consequent actions at reference points J1 and M2 .....	44
	10.2	Defects or failures at reference points A2 of the 2 048 kbit/s CCITT Recommendation G.703 aggregate Physical Interface and consequent actions at reference points A1 and B2 (or G2) .....	45
		10.2.1 Defect or failure conditions at reference points A2 or A1 of the 2 048 kbit/s CCITT Recommendation G.703 aggregate Physical Interface .....	45
		10.2.2 Consequent actions at reference points A1 and B2 (or G2) .....	47
	10.3	Defects or failures at reference points G2 and consequent actions at reference points G1 and H2 (or J2) .....	47
		10.3.1 Defect or failure conditions at reference points G2 .....	47
		10.3.1.1 Loss of frame alignment .....	47
		10.3.1.2 Excessive bit error ratio .....	47
		10.3.1.3 Defect indications from a remote equipment in TS 0 .....	48
		10.3.1.4 Reception of alarm indication signal.....	48
		10.3.1.5 Loss of multiframe alignment .....	48
		10.3.1.6 Defect indication from a remote equipment in TS 16 .....	48
		10.3.1.7 Reception of alarm indication signal in TS 16 .....	48
		10.3.1.8 Frame slip.....	49
		10.3.1.9 CRC4 block error.....	49
		10.3.1.10 Remote CRC4 block error .....	49
		10.3.2 Consequent actions at reference points G1 and H2 (or J2).....	49
	10.4	Defects or failures at reference points P1 or P2 and consequent actions at reference points P2 and M1 (or J1).....	50
		10.4.1 Defects or failure conditions at reference points P1 or P2.....	50

10.4.1.1	2-wire/4-wire voice band (3 400 Hz) interface.....	51
10.4.1.2	2-wire/4-wire voice band (3 400 Hz) with d.c. signalling interface .....	51
10.4.1.3	PSTN interface.....	51
10.4.1.4	Wide band interface (7 kHz) .....	51
10.4.1.5	CCITT Recommendation G.703/64 kbit/s codirectional interface .....	51
10.4.1.6	CCITT Recommendation X.24 interface.....	51
10.4.1.7	CCITT Recommendation V.24 (V.10 and V.11) interface...	52
10.4.1.8	Integrated baseband transmission system for data interfaces .....	52
10.4.1.9	CCITT Recommendation G.704 formatted n x 64 kbit/s signal interface .....	52
10.4.1.10	ISDN interfaces.....	52
10.4.1.11	CCITT Recommendation G.703/2 048 kbit/s unstructured interface .....	52
10.4.2	Consequent actions at reference points P2 and M1 (or J1) .....	53
10.4.2.1	2-wire/4-wire voice band (3 400 Hz) interface.....	53
10.4.2.2	2-wire/4-wire voice band (3 400 Hz) with d.c. signalling interface .....	53
10.4.2.3	PSTN interface.....	53
10.4.2.4	Wide band interface (7 kHz) .....	53
10.4.2.5	CCITT Recommendation G.703/64 kbit/s codirectional interface .....	53
10.4.2.6	CCITT Recommendation X.24 interface.....	54
10.4.2.7	CCITT Recommendation V.24 (V.10 and V.11) interface...	54
10.4.2.8	Integrated baseband transmission system for data interfaces .....	54
10.4.2.9	CCITT Recommendation G.704 formatted n x 64 kbit/s signal interface .....	54
10.4.2.10	ISDN interfaces.....	55
10.4.2.11	CCITT Recommendation G.703/2 048 kbit/s unstructured interface .....	56
11	Performance monitoring .....	56
12	Test functions .....	56
Annex A (normative):	Differentiating between user information and network failure indication.....	57
A.1	Signal processing (subclause 9.2.2.2).....	57
A.2	Configurable parameters (subclause 9.2.2.7) .....	57
A.3	CCITT Recommendation X.24 interface (subclause 10.4.1.6).....	57
A.4	Signal processing (subclause 9.2.3.2).....	57
A.5	Configurable parameters (subclause 9.2.3.7) .....	58
A.6	CCITT Recommendation V.24(V.10 and V.11) interface (subclause 10.4.1.7).....	58
A.7	CCITT Recommendation X.24 interface (subclause 10.4.2.6).....	58
A.8	CCITT Recommendation V.24 (V.10 and V.11) interface (subclause 10.4.2.7).....	59
Annex B (normative):	Analogue tributary interfaces, 32 kbit/s coding .....	60
B.1	2-wire/4-wire voice band (3 400 Hz) interface .....	60
B.1.1	Physical interface .....	60
B.1.2	Coding.....	60
B.1.3	Performance.....	60
B.1.4	Signalling.....	60

B.1.5	Signal at reference point M .....	60
B.1.6	Cross connection rules .....	60
B.1.7	Configurable parameters .....	61
B.1.8	Test functions .....	61
B.2	2-wire/4-wire voice band (3 400 Hz) with d.c. signalling interface.....	61
B.2.1	Physical interface .....	61
B.2.2	Coding.....	61
B.2.3	Performance .....	61
B.2.4	Signalling .....	62
B.2.5	Signal at reference point M.....	62
B.2.6	Cross connection rules .....	62
B.2.7	Configurable parameters .....	62
B.2.8	Test functions .....	63
B.3	Defects or failure conditions at reference points P1 or P2.....	63
B.3.1	2-wire/4-wire voice band (3 400 Hz) interface .....	63
B.3.2	2-wire/4-wire voice band (3 400 Hz) with d.c. signalling interface .....	63
B.4	Consequent actions at reference points P2 and M1 (or J1).....	63
B.4.1	2-wire/4-wire voice band (3 400 Hz) interface .....	63
B.4.2	2-wire/4-wire voice band (3 400 Hz) with d.c. signalling interface .....	64
Annex C (informative): The position and use of loopbacks for testing data channels .....		65
C.1	The use of loopbacks .....	65
C.2	Local loopbacks.....	65
C.2.1	Local loopbacks CCITT Recommendation X.150.....	65
C.2.1.1	Loopback 1 .....	65
C.2.1.2	Loopback 3c.....	65
C.2.1.3	Loopback 3b.....	66
C.2.2	Local loopbacks CCITT Recommendation V.54.....	66
C.2.2.1	Loopback 1.....	66
C.2.2.2	Loopback 3.....	66
C.3	Remote loopbacks .....	67
C.3.1	Remote loopbacks CCITT Recommendation X.150 .....	67
C.3.1.1	Loopback 4b.....	67
C.3.1.2	Loopback 2b.....	67
C.3.2	Remote loopbacks CCITT Recommendation V.54 .....	67
C.3.2.1	Loopback 4.....	67
C.3.2.2	Loopback 2.....	68
Annex D (informative): Special functions .....		69
D.1	Analogue multipoint conference bridge .....	69
D.1.1	General .....	69
D.1.2	Code conversion .....	70
D.1.2.1	64 kbit/s PCM .....	70
D.1.2.2	32 kbit/s ADPCM.....	70
D.1.2.3	64 kbit/s SB-ADPCM .....	70
D.1.3	Summing of uniform PCM signals .....	70
D.1.3.1	Summing .....	70
D.1.3.2	Overload.....	70
D.1.3.3	Offset control .....	71
D.1.3.4	AIS signal elimination .....	71
D.1.3.5	Delay .....	71
D.1.3.6	Configuration .....	71
D.1.4	Signalling .....	71
D.1.5	Network aspects .....	72
D.2	Data multipoint bridge .....	72

D.2.1	General.....	72
D.2.2	Multipoint data bridge not using end to end control signals .....	72
D.2.2.1	Master to slaves.....	73
D.2.2.2	Slaves to master .....	73
D.2.2.3	Delay.....	73
D.2.2.4	Configuration .....	73
D.2.3	Multipoint data bridge using end-to-end control signals .....	74
D.2.3.1	Master to slaves.....	74
D.2.3.2	Slaves to master .....	74
D.2.3.3	Delay.....	75
D.2.3.4	Configuration .....	75
D.3	Broadcasting.....	75
Annex E (informative):	Possible methods for transferring control signals at reference point M.....	76
E.1	Channel associated signalling in TS 16.....	76
E.2	In-band procedure .....	76
E.3	Other methods.....	76
Annex F (informative):	Test functions .....	77
F.1	Internal self tests.....	77
F.2	Tributary tests and transmission testing .....	77
Annex G (informative):	Bibliography .....	78
History .....		79



## Foreword

This draft European Telecommunication Standard (ETS) has been produced by the Transmission and Multiplexing (TM) Technical Committee of the European Telecommunications Standards Institute (ETSI), and is now submitted for the Public Enquiry phase of the ETSI standards approval procedure.

This draft European Telecommunication Standard (ETS) has been produced in order to meet the requirements of network operators and equipment manufacturers for the deployment and design of Flexible Multiplexers to be used in leased line and public network applications.

This ETS consists of 2 parts as follows:

**Part 1:** "Core functions, 2 048 kbit/s aggregate interface functions, tributary interface functions and special functions".

Part 2: "Management and control functions" (DE/TM-01013-3).

<b>Proposed transposition dates</b>	
Date of latest announcement of this ETS (doa):	3 months after ETSI publication
Date of latest publication of new National Standard or endorsement of this ETS (dop/e):	6 months after doa
Date of withdrawal of any conflicting National Standard (dow):	6 months after doa

Blank page

## 1 Scope

This draft European Telecommunication Standard (ETS) gives the characteristics of a Flexible Multiplexer (FM) equipment; the related functions able to handle a variety of services with transparency for the service provider, allowing enhanced management capabilities to be used in the access network. The services considered are related to digital leased line networks and transparent transfer of 2 048 kbit/s signals in applications such as Integrated Services Digital Network (ISDN) primary rate and access or 2 048 kbit/s ONP leased line. ISDN basic access and Public Switched Telephone Network (PSTN) may be subject to further consideration according to V5 interface standards. Tributaries of this multiplexer provide interfaces related to the services to which it is connected. Internal mapping functions are based on 64 kbit/s and  $n \times 64$  kbit/s signals. The handling of sub 64 kbit/s signals is not precluded and is considered as an option to the equipment. Also covered are the characteristics of 2 048 kbit/s aggregate frames based on CCITT Recommendation G.704 [4] and on ETS 300 167 [35] with optional path protection and 2 048 kbit/s aggregate termination based on CCITT Recommendation G.703 [3] and on ETS 300 166 [31] with optional section protection. Each aggregate frame based on CCITT Recommendation G.704 [4] and on ETS 300 167 [35] may contain multiple services.

The requirements contained in this ETS are only for the purpose of describing the functions of the multiplexer and are not intended to represent actual implementations.

Part 2 of this ETS covers the management of the FM which is in line with the general principles of the Telecommunication Management Network (TMN).

## 2 Normative references

This ETS incorporates by dated and undated reference, provisions from other publications. These normative references are cited at the appropriate places in the text and the publications are listed hereafter. For dated references, subsequent amendments to or revisions of any of these publications apply to this ETS only when incorporated in it by amendment or revision. For undated references the latest edition of the publication referred to applies.

- [1] CCITT Recommendation G.172 (1988): "Transmission plan aspects of international conference calls".
- [2] CCITT Recommendation G.181 (1988): "Characteristics of 1+1 type restoration systems for use on digital transmission links".
- [3] CCITT Recommendation G.703 (1991): "Physical/electrical characteristics of hierarchical digital interfaces".
- [4] CCITT Recommendation G.704 (1991): "Synchronous frame structures used at primary and secondary hierarchical levels".
- [5] CCITT Recommendation G.706 (1991): "Frame alignment and cyclic redundancy check (CRC) procedures relating to basic frame structures defined in Recommendation G.704".
- [6] CCITT Recommendation G.711 (1988): "Pulse code modulation (PCM) of voice frequencies".
- [7] CCITT Recommendation G.712 (1991): "Performance characteristics of PCM channels". Study Group XV - Report R70 November 1991.
- [8] CCITT Recommendation G.721 (1988): "32 kbit/s adaptive differential pulse code modulation (ADPCM)".
- [9] CCITT Recommendation G.722 (1988): "7 kbit/s audio-coding within 64 kbit/s".
- [10] CCITT Recommendation G.725 (1988): "System aspects for the use of 7 kHz audio codec within 64 kbit/s".

- [11] CCITT Recommendation G.732 (1988): "Characteristics of a primary PCM multiplexer equipment operating at 2 048 kbit/s".
- [12] CCITT Recommendation G.736 (1988): "Characteristics of a synchronous digital multiplex equipment operating at 2 048 kbit/s".
- [13] CCITT Recommendation G.761 (1988): "General characteristics of a 60-channel transcoder equipment".
- [14] CCITT Recommendation G.811 (1988): "Timing requirements at the outputs of primary reference clocks suitable for plesiochronous operation of international digital links".
- [15] CCITT Recommendation G.823 (1988): "The control of jitter and wander within digital networks which are based on the 2 048 kbit/s hierarchy".
- [16] CCITT Recommendation H.221 (1988): "Frame structure for a 64 kbit/s channel in audiovisual teleservices".
- [17] CCITT Recommendation M.3010 (1988): "Principles for a telecommunication management network".
- [18] CCITT Recommendation V.10 (1988): "Electrical characteristics for unbalanced double-current interchange circuits for general use with integrated circuit equipment in the field of data communications".
- [19] CCITT Recommendation V.11 (1988): "Electrical characteristics for balanced double-current interchange circuits for general use with integrated circuit equipment in the field of data communications".
- [20] CCITT Recommendation V.13 (1988): "Simulated carrier control".
- [21] CCITT Recommendation V.24 (1988): "List of definitions for interchange circuits between data terminal equipment (DTE) and data circuit-terminating equipment (DTE)".
- [22] CCITT Recommendation V.35 (1984): "Data transmission at 48 kilobits per second using 60-108 kHz group band circuits".
- [23] CCITT Recommendation V.35 (1988): "Data transmission at 48 kilobits per second using 60-108 kHz group band circuits".
- [24] CCITT Recommendation V.38 (1992): "A 48/56/64 kbit/s data circuit-terminating equipment standardized for use on digital leased circuits".
- [25] CCITT Recommendation V.54 (1988): "Loop test devices for modems".
- [26] CCITT Recommendation X.150 (1988): "Principles of maintenance testing for public data networks using data terminal equipment (DTE) and data circuit-terminating equipment (DCE) test loops".
- [27] CCITT Recommendation X.21 (1988): "Interface between data terminal equipment (DTE) and data circuit-terminating equipment (DCE) for synchronous operation on public networks".
- [28] CCITT Recommendation X.24 (1988): "List of definitions for interchange circuits between data terminal equipment (DTE) and data circuit-terminating equipment (DTE) on public data networks".
- [29] CCITT Recommendation X.27 (1988): "Electrical characteristics for balanced double-current interchange circuits for general use with integrated circuit equipment in the field of data communications".

- [30] prETS 300 132 (1994): "Equipment Engineering (EE); Power supply interface at the input to telecommunications equipment interface".
- [31] ETS 300 166 (1993): "Transmission and Multiplexing (TM); Physical and electrical characteristics of hierarchical digital interfaces for equipment using the 2 048 kbit/s - based plesiochronous or synchronous digital hierarchies".
- [32] ETS 300 167 (1993): "Transmission and Multiplexing (TM); Functional characteristics of 2 048 kbit/s interfaces".
- [33] ETR 135 (1994): "Transmission and Multiplexing (TM); Network aspects and applications for a 4 (and n x 4) kbit/s data link in a 2 048 kbit/s frame".
- [34] ISO 4903 (1980): "Data communication - 15-pin DTE/DCE interface connector and pin assignments".
- [35] DE/TM-01013-3: "Transmission and Multiplexing (TM); Flexible Multiplexer (FM) equipment; Part 2: Management and control functions".

### 3 Definitions

For the purposes of this ETS, the following definitions apply.

**blocking factor:** The existence of connections in a mapping function can block the establishment of any new connections. The blocking factor is the probability that a new connection cannot be made, expressed as a decimal fraction of 1.

**channel associated signalling cross connection capacity:** This consists in the maximum number of equivalent channels at 4 x 500 bit/s supported by the TS 16 Channel Associated Signalling (CAS) multiframe which can be cross connected within the equipment.

**cross connection capacity:** This consists in the maximum number of equivalent channels at 64 kbit/s which can be cross connected within the equipment.

NOTE: Cross connection of Time Slot 0 (TS 0) (or bits 1 to 8 of 2 048 kbit/s CCITT Recommendation G.704 [4] frame) or TS 16 information according to CCITT Recommendation G.704 [4] should be considered as equivalent to a 64 kbit/s channel.

**Flexible Multiplexer (FM):** A device that provides time division multiplexing and demultiplexing of a variety of user services. In addition the device provides enhanced management capabilities.

**leased line:** A transparent connection leased from a public telecommunications carrier and which is not part of the PSTN.

**octet sequence integrity:** The property of a digital connection that permits a digital signal to be conveyed over it without change to the order of the octets.

**receiver:** The part of the equipment which terminates an input to the equipment.

**synchronization signal:** A clock control signal obtained from a synchronization network.

**transmitter:** The part of the equipment which generates an output from the equipment.

### 4 Symbols and abbreviations

For the purposes of this ETS, the following symbols and abbreviations apply. See also the reference model and reference points given in clause 6.

ADPCM	Adaptive Differential Pulse Code Modulation
AIS	Alarm Indication Signal

CAS	Channel Associated Signalling
CAS XC	Channel Associated Signalling Cross Connection
CRC	Cyclic Redundancy Check
DCE	Data Circuit-terminating Equipment
DTE	Data Terminal Equipment
DXC	Digital cross Connect
EMF	Equipment Management Function
ENV	Environmental function
EOC	Embedded Operation Channel
F	A management interface connecting workstation to the OSF or the MF according to CCITT Recommendation M.3010 [17]
FM	Flexible Multiplexer
ISDN	Integrated Services Digital Network
LC	a non-standard Local Control interface
LOS	Loss Of Signal
LPPSW	Lower order Path Protection Switch
LSPSW	Lower order Section Protection Switch
m	A non-standard reference point between equipment function and the Q Adapter function according to CCITT Recommendation M.3010 [17]
MCF	Message Communication Function
MF	Mediation Function
MTS	Multiplexer Timing Source
NFAS	Non-Frame Alignment Signal
NTU	Network Terminating Unit
OAN	Optical Access Network
ONP	Open Network Provision
OSF	Operations Systems Function
PABX	Private Automatic Branch Exchange
PCM	Pulse Code Modulation
PDH	Plesiochronous Digital Hierarchy
PI	Physical Interface
PLPT	Plesiochronous Lower order Path Termination
ppm	part per million
PSTN	Public Switched Telephone Network
PWR	Powering function
QAF	Q Adapter Function
RAI	Remote Alarm Indication
ROT	Remove Octet Timing
RP	Reference Point
SB-ADPCM	Sub-Band Adaptive Differential Pulse Code Modulation
SDH	Synchronous Digital Hierarchy
SF	Special Function
STM-1	Synchronous Transport Module level 1
TIPi	Timing Input Physical Interface
TMN	Telecommunication Management Network
TOPI	Timing Output Physical Interface
TPT	Tributary Path Termination
TS	Time Slot from a 2 048 kbit/s CCITT Recommendation G.704 [4] frame
TS n	Time Slot number n (from 0 to 31)
TSA	Tributary Signal Adaptation
TST	Tributary Signal Termination
XC	Cross Connection function

## 5 Network reference configuration

There is no reference configuration recommended for the application of Flexible Multiplexer (FM). Nevertheless, it is considered that the FM can be used as a stand alone equipment capable of being connected via a Plesiochronous Digital Hierarchy (PDH) or Synchronous Digital Hierarchy (SDH) transmission system to a service network. The service network may contain cross connect equipment, particularly for the leased line case. The related functions of the FM may be also integrated into digital PDH or SDH transmission structures. It is also appropriate that the corresponding functional blocks of this ETS may be considered for use within Optical Access Network (OAN).

## 6 Reference model and reference points

The reference model of the FM is shown in figure 1. The aggregate interface shown in figure 1, and standardized in this part of the ETS, is a 2 048 kbit/s CCITT Recommendation G.703 [3] interface.

Optionally, the FM or the related functions may be integrated in a PDH, SDH or OAN system. As an alternative to the optional integrated transmission equipment shown in figure 1 external transmission equipment may be connected at the 2 048 kbit/s CCITT Recommendation G.703 [3] aggregate interface(s).

At reference points H, J, K, M and N shown in figure 1, 64 kbit/s channels carry information corresponding to 64 kbit/s signals or TSs at Reference points G and O. If channel associated signalling is provided then at reference points H, J, K, L, M and N the 4 x 500 bit/s channels carry information corresponding to the channel associated signalling or control a, b, c, and d bits at reference points G and O.

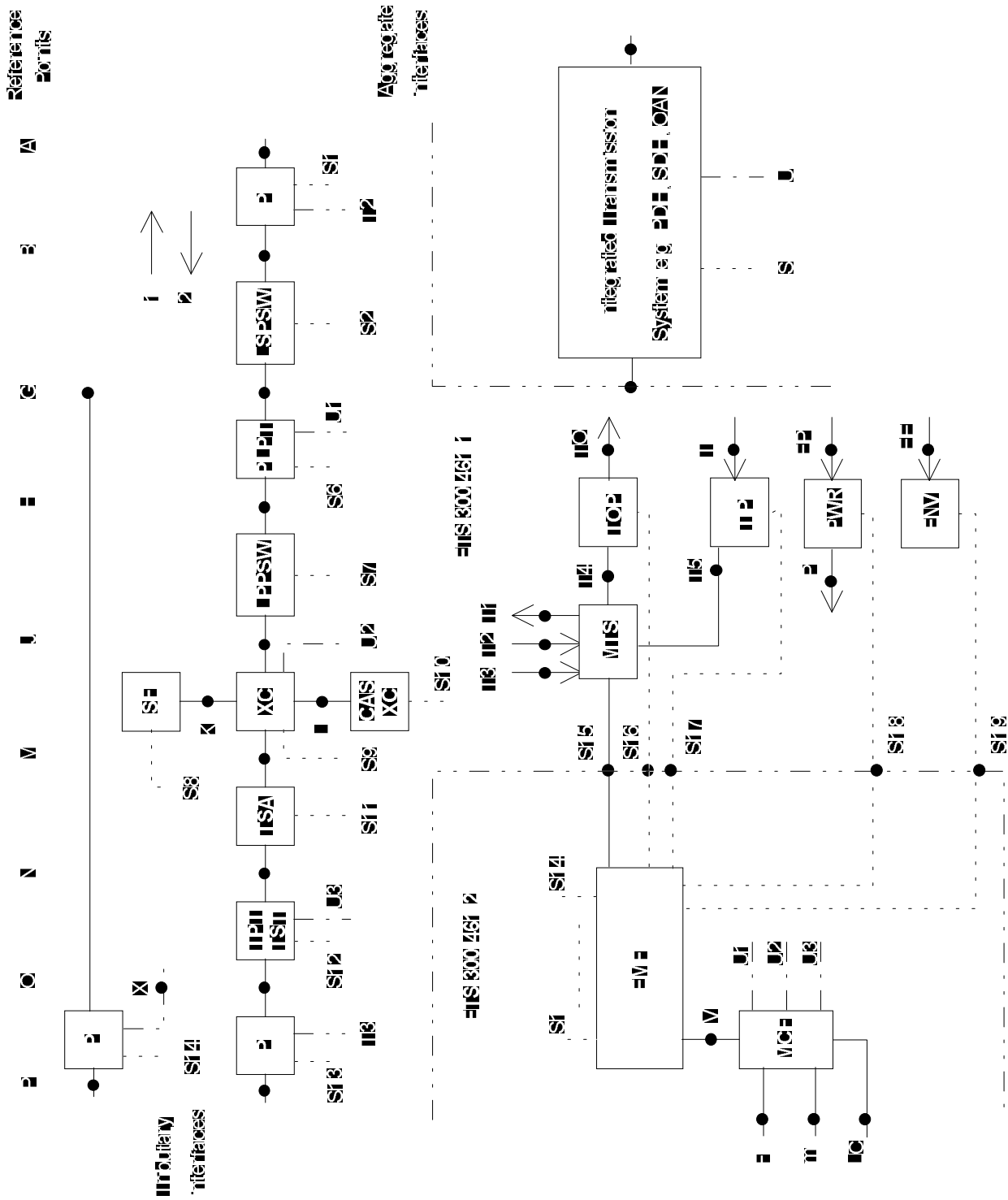

Figure 1: Functional diagram of the FM

Notes to figure 1.

- NOTE 1: T1 and IP are distributed to all the other functional blocks.
- NOTE 2: Not all functional blocks and reference points need to be considered.
- NOTE 3: Not all the necessary functions are shown; e.g. internal code conversion or line protection.
- NOTE 4: Reference points A to J and M to P can each be divided into two reference points. e.g. A1 and A2 relate to the reference point P to A and A to P directions respectively.



- NOTE 5: Reference point K can be divided into two reference points K1 and K2 that relate to the XC to SF and SF to XC directions respectively.
- NOTE 6: Reference point L can be divided into two reference points L1 and L2 that relate to the XC to CAS XC and CAS XC to XC directions respectively.
- NOTE 7: Reference point X can be divided into two reference points X1 and X2 that relate to P to A and A to P directions respectively.
- NOTE 8: The functional reference model and the defined reference points are only for the purpose of describing the functions of the multiplexer and are not intended to represent actual implementations. Reference to 64 kbit/s TS at internal reference point U2 refers only to the logical processing/mapping of the information content as observed from the external interfaces and do not impose a physical constraint within the equipment.

Key to figure 1.

- PI: Physical Interface. This function terminates and generates the signals of either a tributary or an aggregate circuit. The PI functional block recovers the timing signal (X or T2 reference point) from the received signal. The function detects loss of signal condition. When appropriate, the line code violations are also detected.
- LSPSW: Lower order Section Protection Switch. This optional function is used when 1+1 protection switching is required for the 2 048 kbit/s digital section.
- PLPT: Plesiochronous Lower Order Path Termination. This function terminates and generates a logical signal at 2 048 kbit/s at an aggregate interface. The function provides frame generation and recovery and detection of defect and failure conditions on the 2 048 kbit/s logical signal.
- LPPSW: Lower order Path Protection Switch. This optional function is used when either 1+1 or 1 for n protection switching is required for the 2 048 kbit/s digital path.
- XC: Cross Connection Function. This function allows the cross connection of 64 and n x 64 kbit/s signals between the same or different reference points.
- CAS XC: Channel Associated Signalling Cross Connection Function. If channel associated signalling or control is used then this function allows the cross connection of the associated signalling signals at 4 x 500 bit/s or n x 4 x 500 bit/s between the same or different reference points.
- SF: Special Function. Examples of optional special functions are analogue multipoint conference bridge, data multipoint bridge and broadcasting.
- TSA: Tributary Signal Adaptation. This function modifies the tributary signal, when necessary, into a 64 kbit/s channel suitable for the cross connection function. It also carries out the reverse function.
- TPT/TST: Tributary Path Termination/Tributary Signal Termination. This function generates or terminates tributary information and any related signalling or control signals. If the tributary signal is a 2 048 kbit/s signal formatted in accordance with CCITT Recommendation G.704 [4] and with ETS 300 167 [35] then this function is similar to that of the PLPT.
- TIPI: Timing Input Physical Interface. This function terminates an external 2 048 kHz synchronization input.
- TOPI: Timing Output Physical Interface. This function transmits an external 2 048 kHz synchronization output.

MTS:	Multiplexer Timing Source. This function provides all internal timing signals necessary for the FM.
PWR:	Powering function. This function converts external power source at the external power interface (EP) for appropriate internal power (IP) distribution.
ENV:	Environmental function. When appropriate, this function provides notification to the EMF function of any relevant environmental event (EE).
EMF:	Equipment Management Function. This function is connected to all the other functional blocks and provides for a local user or the TMN capability to perform all the management functions of the FM.
MCF:	Message Communication Function. This function terminates and generates the FM management control channel(s). The control channel may be an embedded operations channel (EOC) transported in one or more Sa bit and accessed via reference point U1 or U3 or it may be transported in a 64 kbit/s TS accessed via reference point U2. There may be EOCs at either or both the aggregate or tributary side of the FM. The function is also able to interwork as a relay function between a local workstation connected via a F interface to the TMN. Alternatively, access to the TMN may also be provided locally through an m interface and a QAF. Direct access to essential internal management functions via a LC interface shall be provided. The m and LC interfaces are not subject to standardization.

## 7 Core functions

### 7.1 Cross connection functions

The cross connection functions XC, and optionally CAS XC, make cross connections between the reference points of tributaries, aggregates and special functions. A cross connection may be either unidirectional or bidirectional. It should be possible to cross connect between any two interfaces as follows:

a)	tributary	-	aggregate	RP:M	-	RP:J	
b)	aggregate	-	aggregate	RP:J	-	RP:J	note 1
c)	tributary	-	special function	RP:M	-	RP:K	note 2
d)	aggregate	-	special function	RP:J	-	RP:K	note 2
e)	tributary	-	tributary	RP:M	-	RP:M	note 3

NOTE 1: Aggregate, aggregate cross connection is an optional function.

NOTE 2: Applicable when special functions are provided.

NOTE 3: Tributary, tributary cross connection is an optional function.

Cross connection shall be provided with the following granularity:

- XC, cross connection of  $n \times 64$  kbit/s ( $n = 1$  to 31) channels;
- optional CAS XC, cross connection of  $n \times 4 \times 500$  bit/s ( $n = 1$  to 30) channels used for channel associated signalling or control.

The blocking factor of the Cross Connection function (XC) should be zero for any combination of 64 kbit/s and  $n \times 64$  kbit/s signals with a total bit rate not exceeding the cross connection capacity of the equipment and within the cross connection rules for each tributary type.

The blocking factor of the optional Channel Associated Signalling Cross Connection function (CAS XC) should be zero for any combination of 4 x 500 bit/s and  $n \times 4 \times 500$  bit/s signals with a total bit rate not exceeding the channel associated signalling cross connection capacity of the equipment and within the channel associated signalling cross connection rules for each tributary type.

The cross connection function (XC) in association with the PLPT, LPPSW, TSA, TPT/TST functions shall maintain octet integrity for 64 kbit/s signals and  $n \times 64$  kbit/s signals and in addition octet sequence integrity for  $n \times 64$  kbit/s signals.

The optional channel associated signalling cross connection function (CAS XC) in association with the PLPT, LPPSW, TSA, TPT/TST functions shall maintain the integrity of each 4 x 500 bit/s signal, the integrity and sequence integrity of each  $n \times 4 \times 500$  bit/s signal in coherence with the corresponding TS arrangement.

NOTE 1: For some  $n \times 64$  kbit/s applications it may be necessary to maintain octet sequence integrity within each frame.

NOTE 2: The handling of traffic, common channel signalling and control channel having bit rates lower than 64 kbit/s is not precluded. These functions may require the cross connection of sub-64 kbit/s rates.

The cross connection function (XC) shall cause an idle pattern of all ones in unused 64 kbit/s TSs at reference points G1 and O2. If channel associated signalling or control is provided then the channel associated cross connection function (CAS XC) shall cause an idle pattern of all ones in unused 4 x 500 bit/s signalling channels at reference point G1 and O2.

If a 64 kbit/s TS is used to carry an embedded operations channel it shall be passed to the Message Communication Function via reference point U2.

## 7.2 Multiplexer Timing Source

It should be possible to derive the multiplexer internal timing signal, reference point T1, from any of the following:

- a) one of a number of external source(s) at 2 048 kHz in accordance with subclause 7.4 reference point T5;
- b) one of a number of 2 048 kbit/s aggregate signal(s), reference point T2;
- c) one of a number of 2 048 kbit/s CCITT Recommendation G.704 [4] formatted  $n \times 64$  kbit/s tributary signal(s), reference point T3;
- d) an internal oscillator with a frequency accuracy of a range from  $\pm 1$  ppm to  $\pm 50$  ppm depending on application.

The internal oscillator should not be used as a primary timing source when the multiplexer is connected to the synchronous network.

Under failure of the primary timing source, the multiplexer shall fall back to the secondary source(s) in accordance with a pre-determined sequence as specified in part 2 of this ETS (DE/TM-01013-3 [35]).

The output jitter at the aggregate interface or at a 2 048 kbit/s tributary interface and the jitter transfer between the timing source and the aggregate interface or a 2 048 kbit/s tributary interface shall be in accordance with subclause 8.4.3, subclause 9.3.3 or subclause 9.5.3.

The provision of a timing signal output, reference point T4, for the purpose of synchronising other equipment is an option which might be required depending on the application. If provided the interface shall be in accordance with subclause 7.4.

NOTE: Any 2 048 kbit/s aggregate unstructured signal should not be selected as a candidate for the timing source for the multiplexer.

### 7.3 Control functions

The Equipment Management Function (EMF) and Message Communication Function shall be in accordance with part 2 of this ETS (DE/TM-01013-3 [35]).

### 7.4 Timing interfaces at 2 048 kHz

The physical and electrical characteristics of the Timing Input Physical Interface (TIPI) at reference point TI shall be in accordance with CCITT Recommendation G.703 [3], § 10.3 and with ETS 300 166 [31]. If provided the physical and electrical characteristics of the Timing Output Physical Interface (TOPI) at reference point TO shall be in accordance with CCITT Recommendation G.703 [3], § 10.2 and with ETS 300 166 [31].

### 7.5 Power supply interface

It shall be possible to derive the equipment power from one or two d.c. power supply interfaces (EP) in accordance with ETS 300 132 [30]. The provision of an a.c. power supply is an option for the equipment, it is not subject to standardization.

### 7.6 Configurable parameters

The following parameters shall be configurable by the EMF via reference points S8, S9, S10, S14, S15, S16 or S17 in accordance with part 2 of this ETS (DE/TM-01013-3 [35]):

- a) selection of the synchronization source(s);
- b) Multiplexer Timing Source (MTS) fall back sequence;
- c) provisioning of channel associated signalling cross connection function;
- d) activation and deactivation of special functions, see annex D;
- e) provisioning of a TS to provide a 64 kbit/s embedded operations channel at reference point U2;
- f) provisioning of 2 048 kbit/s channel to be passed directly from reference point G to reference point O.

### 7.7 Test functions

The following test function shall be provided controlled by the EMF via reference points S6, S7 or S9 in accordance with part 2 of this ETS (DE/TM-01013-3 [35]):

loopback at 64 or  $n \times 64$  kbit/s, as required by the circuit, by cross connection from reference point J2 to reference point J1.

More information on the position and use of loopbacks for data channels is given in annex C. Indication on tests that can be used with loopbacks are given in clause 12.

## 8 Aggregate interfaces

The FM can have a variety of aggregate interface types between reference point A and reference point G. One or more aggregate interfaces shall be provided.

The aggregate interface(s) between reference point A and reference point G shall be in accordance with subclause 8.2. The Plesiochronous Lower order Path Termination function shall be in accordance with subclause 8.4 and the LPPSW function shall be in accordance with subclause 8.5.

## 8.1 Reference point G

Except the case of provisioning transparent 2 048 kbit/s signals i.e. where no structure does exist, the basic 2 048 kbit/s frame structure at reference point G shall be in accordance CCITT Recommendation G.704 [4], §§ 2.3.1 and §§ 2.3.2 and with ETS 300 167 [35]. Bit 1 of the frame shall be used for the CRC4 procedure in accordance with CCITT Recommendation G.704 [4], §§ 2.2.3 and with ETS 300 167 [35].

The basic frame structure is divided into 32 octet interleaved TSs and carries  $n \times 64$  kbit/s signals ( $n = 1$  to 31 or  $n = 1$  to 30 depending on the application) in accordance with CCITT Recommendation G.704 [4], § 5 and with ETS 300 167 [35]. TS 16 may carry channel associated signalling or control in accordance with CCITT Recommendation G.704 [4], §§ 5.1.3.2 and with ETS 300 167 [35].

An embedded operations channel as described in ETR 135 [33] for management and control functions may be provided using bit Sa4 in TS 0 of the 2 048 kbit/s CCITT Recommendation G.704 [4] frame and, if more capacity is required, other Sa bits (for example Sa8). Alternatively a 64 kbit/s TS could be used for the control channel. In some cases, an embedded operations channel may not be provided. The embedded operations channel shall be in accordance with that specified in part 2 of this ETS (DE/TM-01013-3 [35]).

## 8.2 2 048 kbit/s CCITT Recommendation G.703 aggregate interface

### 8.2.1 Physical Interface function

This optional interface provides a 2 048 kbit/s CCITT Recommendation G.703 [3] interface to reference point G, or reference point B if the Lower order Section Protection Switch (LSPSW) function is provided.

#### 8.2.1.1 Physical interface

The electrical characteristics of the interface at reference point A shall be in accordance with CCITT Recommendation G.703 [3], § 6 and with ETS 300 166 [31]. The 75  $\Omega$  coaxial pair option, or 120  $\Omega$  symmetrical pair option, should be provided as required by the application.

#### 8.2.1.2 Signal processing

The Physical Interface function shall detect Loss Of incoming Signal (LOS) at reference point A2 in accordance with subclause 10.2.1.

#### 8.2.1.3 Performance

The output jitter, at reference point A1, when the timing source is jitter free shall be in accordance with CCITT Recommendation G.736 [12], §§ 6.1.

The input jitter tolerance, at reference point A2, shall be in accordance with CCITT Recommendation G.823 [15], §§ 3.1.1.

The jitter transfer function between the received 2 048 kbit/s aggregate signal used for synchronization and the transmit 2 048 kbit/s aggregate signal at reference point A1 shall be in accordance with CCITT Recommendation G.736 [12], §§ 6.3.1 and §§ 6.3.2 with the 40 Hz cut-off option.

#### 8.2.1.4 Control signals

No extra control signals are provided with the signal at reference point A.

### 8.2.1.5 Signal at reference point B (or G)

The signal at reference point B shall have the same format as that at reference point G and shall be in accordance with subclause 8.1. In addition if the optional LSPSW function is provided then at reference point B2 a control signal shall be provided. The control signal shall indicate LOS detected in accordance with subclause 8.2.1.2.

### 8.2.1.6 Mapping rules

Between reference point A and reference point B (or G) the function shall maintain bit sequence integrity.

### 8.2.1.7 Configurable parameters

The following parameter may be configured by the EMF via reference point S1:

activation of bipolar violation counting. Detailed information is provided in part 2 of this ETS (DE/TM-01013-3 [35]).

### 8.2.1.8 Test functions

The following loopback/test function (equipment loopback) shall be provided controlled by the EMF via reference point S1 or S6 in accordance with part 2 of this ETS (DE/TM-01013-3 [35]):

- loopback of the complete 2 048 kbit/s signal from reference point B1 (or G1) to reference point B2 (or G2). The description of the loopback is given in figure 2. This loopback shall be controlled via the m or LC interface.

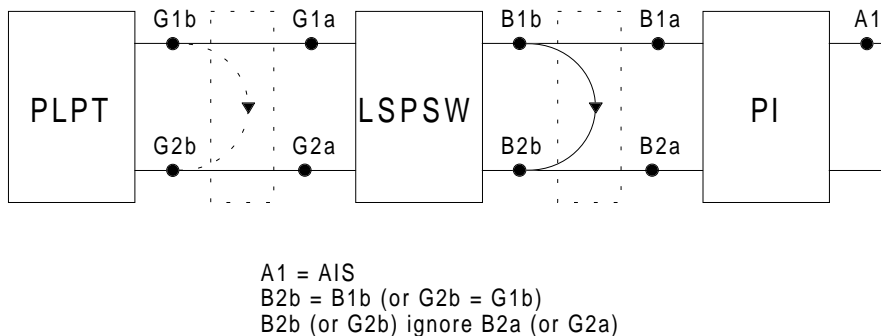

**Figure 2: 2 048 kbit/s aggregate logical loopback description**

The following loopback/test function (line loopback) for the purpose of transmission section testing is an option for the equipment that may be provided via reference point S1 or S6 in accordance with part 2 of this ETS (DE/TM-01013-3 [35]):

- loopback of the complete 2 048 kbit/s signal from reference point B2 (or G2) to reference point B1 (or G1). The description of the loopback is given in figure 3. When provided, this loopback shall be controlled via the m or LC interface.

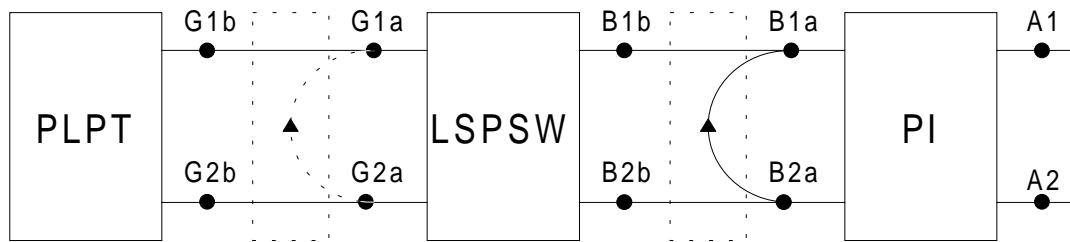

G2b = AIS  
 B1a = B2a (or G1a = G2a)  
 B1a (or G1a) ignore B1b (or G1b)

**Figure 3: 2 048 kbit/s transmission section loopback description**

Indication on tests that can be used with loopbacks are given in annex F.

### 8.2.2 Lower order Section Protection Switch function

This optional function provides 1+1 protection of a 2 048 kbit/s digital section. Each switch function has 2 signals at reference point B and 1 signal at reference point G.

NOTE: The LSPSW function and LPPSW function, as specified in subclause 8.5, shall not both be used on the same aggregate signal.

#### 8.2.2.1 Signal at reference point B

The signal at reference point B shall be in accordance with subclause 8.2.1.5.

#### 8.2.2.2 Signal processing

The two signals sent at reference point B1 shall be the same as that received at reference point G1.

A single signal at reference point G2 shall be produced from the two signals at reference point B2 in accordance with table 2/G.181 of CCITT Recommendation G.181 [2] under the control of the control signals at reference point B2. The two paths shall have equal right as defined in CCITT Recommendation G.181 [2], §§ 3.2.2.

#### 8.2.2.3 Performance

The switching time shall be in accordance with CCITT Recommendation G.181 [2], §§ 3.2.2.

#### 8.2.2.4 Control signals

Control signals are provided at reference point B2 in accordance with subclause 8.2.1.5.

#### 8.2.2.5 Signal at reference point G

The signal at reference point G shall be in accordance with subclause 8.1.

#### 8.2.2.6 Mapping rules

Between reference point B and reference point G the function shall maintain bit sequence integrity.

### 8.2.2.7 Configurable parameters

The following parameters shall be configurable by the EMF via reference point S2 in accordance with part 2 of this ETS (DE/TM-01013-3 [35]):

- a) setting of the section protection switch in any position;
- b) setting of the persistence checking time of the control signal from reference point B2 before protection switching takes place;
- c) forcing the operation on a given section.

The criteria for switching are detailed in part 2 of this ETS (DE/TM-01013-3 [35]).

### 8.2.2.8 Test functions

There is no specific test function to be standardized for this functional block.

## 8.3 Plesiochronous Lower order Path Termination function

The following subclauses detail the functional requirements between reference point G and reference point H, or reference point J if the LPPSW function is not provided. The function processes  $n \times 64$  kbit/s ( $n = 1$  to 31 or  $n = 1$  to 30 depending on the application) signal(s) contained within a 2 048 kbit/s frame in accordance with CCITT Recommendation G.704 [4] and with ETS 300 167 [35]. TS 16 may carry channel associated signalling or control in accordance with CCITT Recommendation G.704 [4] and with ETS 300 167 [35].

### 8.3.1 Signal at reference point G

The signal at reference point G shall be in accordance with subclause 8.1.

### 8.3.2 Signal processing

The loss and recovery of frame alignment and CRC procedures shall be in accordance with CCITT Recommendation G.706 [5], § 4.

If channel associated signalling is provided in TS 16 then loss and recovery of multiframe alignment shall be in accordance with CCITT Recommendation G.732 [11], §§ 5.2.

The function shall pass the  $n \times 64$  kbit/s signals transparently. This includes, if required, channel associated signalling or channel associated control or common channel signalling in TS 16. The embedded operations channel in TS 0, if provided, shall be passed to the Message Communication Function via reference point U1.

The function shall include a suitable buffer to allow for a phase relationship variation between the data received at reference point G2 and the equipment internal timing. This buffer shall also accommodate frequency and phase differences due to the plesiochronous relationship between two synchronized networks conforming to CCITT Recommendation G.811 [14]. Under conditions of plesiochronous working controlled frame slips shall be introduced but loss of frame alignment shall not occur.



### 8.3.3 Performance

The output jitter, at reference point A1, when the timing source is jitter free shall be in accordance with CCITT Recommendation G.736 [12], §§ 6.1.

The input jitter tolerance, at reference point G2, shall be in accordance with CCITT Recommendation G.823 [15], §§ 3.1.1.

The jitter transfer between the input used for synchronization and the 2 048 kbit/s CCITT Recommendation G.703 [3] aggregate interface output at reference point A1 shall be in accordance with CCITT Recommendation G.736 [12], §§ 6.3.1 and §§ 6.3.2 with the 40 Hz cut-off option.

### 8.3.4 Control signals

No extra control signal is provided with the signal at reference point G or H (or J).

### 8.3.5 Signal at reference point H (or J)

At reference point H (or J) one or more  $n \times 64$  kbit/s signals shall be carried in each direction. In addition, if used, the corresponding channel associated  $n \times 4 \times 500$  bit/s signals shall be carried in each direction.

### 8.3.6 Mapping rules

Between reference point G and reference point H (or J) the function shall maintain the integrity of the individual  $n \times 64$  kbit/s signals. In addition, if used, the integrity of each  $n \times 4 \times 500$  bit/s associated signalling signal shall be maintained.

### 8.3.7 Configurable parameters

The following parameters shall be configurable by the EMF via reference point S6 in accordance with part 2 of this ETS (DE/TM-01013-3 [35]):

- a) the value of  $n$  from 1 to 31 for each signal;
- b) concatenation information about the TSs belonging to the same  $n \times 64$  kbit/s signal;
- c) use of TS 16 for channel associated signalling or a 64 kbit/s signal;
- d) provisioning of a Sa bit in TS 0 to provide a 4 kbit/s embedded operations channel at Reference point U1;
- e) provisioning of a Sa bit for additional far end defect or failure information.

### 8.3.8 Test functions

There is no specific loopback/test function to be standardized for this functional block.

## 8.4 Lower order Path Protection Switch function

This optional function provides either 1+1 or 1 for  $n$  protection of a 2 048 kbit/s digital path. Each switch function has 2 or  $n+1$  interfaces at reference point H and 1 or  $n$  interfaces at reference point J.

NOTE: The LPPSW function and LSPSW function, as specified in subclause 8.2.2, shall not both be used on the same aggregate signal.

### 8.4.1 Signal at reference point H

The signal at reference point H shall be in accordance with subclause 8.4.5.

### 8.4.2 Signal processing

#### 8.4.2.1 1+1 protection

In the case of 1+1 protection switching the two signals sent at reference point H1 shall be the same as that received at reference point J1. The single signal at reference point J2 shall be selected from the two signals at reference point H2 under the control of the EMF.

#### 8.4.2.2 1 for n protection

Figure 4 describes connection arrangement in relation with the provision of 1 for n path protection function.

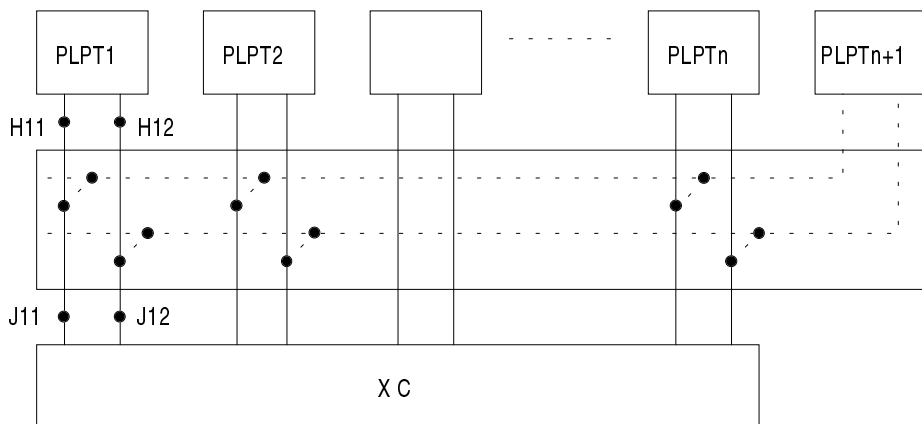

**Figure 4: Functional representation of the LPPSW function**

Under normal operation, the signal at  $H_{i1}$  reference point shall be the same that the LPPSW function receives at  $J_{i1}$  reference point and the signal sent at  $J_{i2}$  reference point shall be the same as that received at  $H_{i2}$  reference point.

Under failure condition on the path terminated at  $PLPT_i$ , the related path will be switched over  $PLPT_{n+1}$  under the control of the EMF so that the signal at  $H_{n+1,1}$  reference point shall be the same that the LPPSW function receives at  $J_{i1}$  reference point and the signal sent at  $J_{i2}$  reference point shall be the same as that received at  $H_{n+1,2}$  reference point. This is illustrated in figure 5.

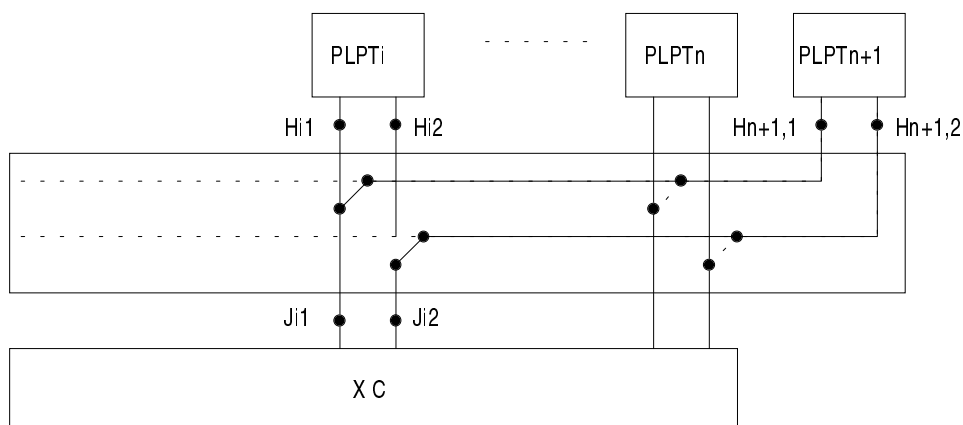

NOTE: The numbering of reference points relates to the associated PLPT functional block as following:  $H_{ij}$  where  $i$  is the PLPT number and  $j$  relates to the direction of signal.

**Figure 5: Protection of path n° i**

#### **8.4.3 Performance**

The performance for this function is not to be standardized.

#### **8.4.4 Control signals**

No extra control signals are provided with the signal at reference point H or J.

#### **8.4.5 Signal at reference point J**

The signal at reference point J shall be in accordance with subclause 8.4.5.

#### **8.4.6 Mapping rules**

Between reference point H and reference point J the function shall maintain bit sequence integrity.

#### **8.4.7 Configurable parameters**

The following parameters shall be configurable by the EMF via reference point S7 in accordance with part 2 of this ETS (DE/TM-01013-3 [35]):

- a) setting of the path protection switch in any position;
- b) enabling/desabling the LPPSW function;
- c) validation of the defect or failure conditions activating the function;
- d) forcing the transmission of one or more of the 2 048 kbit/s aggregate signal(s) on the main or on the (or on one of the) protection path(s);
- e) provision of any priority level to the 2 048 kbit/s paths to be protected.

The criteria for switching are detailed in part 2 of this ETS (DE/TM-01013-3 [35]).

#### **8.4.8 Test functions**

There is no specific test function for this functional block.

### **9 Tributary interfaces**

The FM can have a variety of tributary interface types between reference point P and reference point M. The following tributary types have been standardized so far, other tributary types may be standardized in the future. A choice should be made from the tributary types that follow depending upon the application. The separation into different tributary types should not be taken to imply that they have to be implemented as separate physical interface types.

Additional tributary types are specified in annex B.

#### **9.1 Analogue, 64 kbit/s coding interfaces**

##### **9.1.1 2-wire/4-wire voice band (3 400 Hz) interface**

This optional interface provides 2-wire or 4-wire connections for a voiceband channel in the frequency band 300 Hz to 3 400 Hz without d.c. signalling. The A-law method of coding at 64 kbit/s is specified. This interface type is applicable to analogue leased lines.

**9.1.1.1 Physical interface**

At reference point P a 2-wire or 4-wire interface shall be provided.

The nominal impedance of the interface shall be in accordance with CCITT Recommendation G.712 [7]. References to specific sections of CCITT Recommendations G.712 [7] relating to nominal impedance of 2-wire and 4-wire interfaces are contained in table 1.

**9.1.1.2 Coding**

The analogue signal shall be A-law encoded into 64 kbit/s in accordance with CCITT Recommendation G.711 [6]. Complementary decoding shall also be provided.

**9.1.1.3 Performance**

The overall performance of the channel incorporating both send and receive equipments shall be in accordance with CCITT Recommendation G.712 [7]. When taken separately each send and receive channel shall be in accordance with CCITT Recommendation G.712 [7]. References to specific sections of CCITT Recommendations G.712 [7] relating to characteristics of input and output ports of 2-wire and 4-wire interfaces are contained in table 1.

**Table 1: Analogue performance requirements**

<b>Characteristic (note 1)</b>	<b>4-wire</b>	<b>2-wire</b>
Relative levels at voice frequency ports	§§ 2.1	§§ 2.2
Short- and long-term variation of loss with time	§ 4	§ 4
Nominal impedance and return loss of voice frequency ports	§ 5	§ 5
Impedance unbalance about earth	§ 6	§ 6
Attenuation/frequency distortion	§ 7	§ 7
Group delay (note 2)	§ 8	§ 8
Idle channel noise	§ 9	§ 9
Discrimination against out-of-band signals	§§ 10.1	§§ 10.1
	§§ 10.3	§§ 10.2
Spurious out-of-band signals at the channel output	§§ 11.1	§§ 11.1
Spurious in-band signals at the channel output port	§§ 11.2	§§ 11.2
Total distortion, including quantizing distortion	§ 12	§ 12
Variation of gain with input level	§ 13	§ 13
Crosstalk	§ 14	§ 14
Interference from signalling	§§ 15.1	§§ 15.2
	§§ 15.3	§§ 15.4
Echo and stability	-	§ 16
NOTE 1: Entries in the table refer to sections of CCITT Recommendation G.712 [7].		
NOTE 2: For further study.		

**9.1.1.4 Signalling**

This interface may carry in-band a.c. tone signalling. The equipment will not need to process this signalling.

**9.1.1.5 Signal at reference point M**

At reference point M the tributary signal shall use one 64 kbit/s channel in each direction for the encoded analogue signal.

#### 9.1.1.6 Cross connection rules

If the tributary signal is cross connected to an aggregate interface then:

- a) the signal at reference point M shall use one TS chosen from TSs 1 to 15 or 17 to 31 at reference point G;
- b) if TS 16 at reference point G is not configured for channel associated signalling or control then the signal may use TS 16 at reference point G.

#### 9.1.1.7 Configurable parameters

The following parameters shall be configurable by the EMF via reference point S9, S11, S12 or S13 in accordance with part 2 of this ETS (DE/TM-01013-3 [35]):

- a) 2-wire or 4-wire operation (see note);
- b) audio signal levels;
- c) TS allocation at reference point G.

NOTE: Optionally the selection between 2-wire and 4-wire operation can be done by making a physical change at the tributary interface.

#### 9.1.1.8 Test functions

The following test functions shall be provided and controlled by the EMF via reference points S11, S12 or S13 in accordance with part 2 of this ETS (DE/TM-01013-3 [35]):

- a) connection of the external 2-wire or 4-wire circuit at reference point P to a metallic test bus;
- b) analogue loopback from reference point O2 to reference point O1 or optionally from reference point N2 to reference point N1. With the loopback applied no audio signal shall be present at reference point P2.

Indication on tests that can be used with loopbacks are given in clause 12.

#### 9.1.2 2-wire/4-wire voice band (3 400 Hz) with d.c. signalling interface

This optional interface provides 2-wire or 4-wire connections for a voiceband channel in the frequency band 300 to 3 400 Hz with d.c. signalling. The A-law method of coding at 64 kbit/s is specified. This interface type is mainly applicable for the purpose of analogue Private Automatic Branch Exchange (PABX) or analogue exchanges interconnection.

##### 9.1.2.1 Physical interface

At reference point P a 2-wire or 4-wire interface shall be provided which supports d.c. signalling.

The nominal impedance of the interface shall be in accordance with CCITT Recommendation G.712 [7]. References to specific sections of CCITT Recommendation G.712 [7] relating to nominal impedance of 2-wire and 4-wire interfaces are contained in table 1.

##### 9.1.2.2 Coding

The analogue signal shall be A-law encoded into 64 kbit/s in accordance with CCITT Recommendation G.711 [6]. Complementary decoding shall also be provided.

### 9.1.2.3 Performance

The overall performance of the channel incorporating both send and receive equipment shall be in accordance with CCITT Recommendation G.712 [7]. When taken separately each send and receive channel shall be in accordance with CCITT Recommendation G.712 [7]. References to specific sections of CCITT Recommendation G.712 [7] relating to characteristics of input and output ports of 2-wire and 4-wire interfaces are contained in table 1.

### 9.1.2.4 Signalling

The interface shall provide d.c. signalling. Examples of such signalling systems are:

- a) 2-wire or 4-wire E and M;
- b) an earth calling signalling method for 2-wire interfaces for PABXs;
- c) a loop calling, disconnect clear signalling method for 2-wire interfaces including direct dialling inward/outward for PABXs;
- d) double current d.c. signalling.

The d.c. signalling conditions shall be encoded into the a, b, c, and d bits of channel associated signalling. The complementary decoding shall also be provided. When signalling bits b, c or d are not used they should have the values: b = 1, c = 0, d = 1. It is recommended that the combination "0000" of bits a, b, c and d should not be used for signalling purposes.

Particular specifications for the appropriate signalling method, and its encoding into the a, b, c and d bits, should be determined by individual administrations.

This interface may also carry in-band a.c. tone signalling. The equipment will not need to process this a.c. signalling.

### 9.1.2.5 Signal at reference point M

At reference point M the tributary signal shall use one 64 kbit/s channel in each direction for the encoded analogue signal. In addition the signal at reference point M shall use up to 4 x 500 bit/s associated signalling channels in each direction for the encoded signalling.

### 9.1.2.6 Cross connection rules

If the tributary signal is cross connected to an aggregate interface then:

- a) the signal at reference point M shall use one TS chosen from TSs 1 to 15 or 17 to 31 at reference point G;
- b) the channel associated signalling at reference point M shall use the corresponding a, b, c and d bits in TS 16 at reference point G;

### 9.1.2.7 Configurable parameters

The following parameters shall be configurable by the EMF via reference point S9, S10, S11, S12 or S13 in accordance with part 2 of this ETS (DE/TM-01013-3 [35]):

- a) 2-wire or 4-wire operation (note 1);
- b) audio signal levels;
- c) use of signalling bits;
- d) signalling type (note 2);

- e) default value for d.c. signalling under failure condition;
- f) TS allocation at G reference point;
- g) activation of CAS cross connection function.

NOTE 1: Optionally the selection between 2-wire and 4-wire operation can be done by making a physical change at the tributary interface.

NOTE 2: Optionally the selection of signalling type can be done by making a physical change at the tributary interface. Variation of parameters within a basic signalling type could still be provided by the EMF via reference point S11, S12 or S13.

#### **9.1.2.8 Test functions**

The following test functions shall be provided and controlled by the EMF via reference points S11, S12 or S13 in accordance with part 2 of this ETS (DE/TM-01013-3 [35]):

- a) connection of the external 2-wire or 4-wire circuit, and any additional signalling wires, at reference point P to a metallic test bus;
- b) analogue loopback from reference point O2 to reference point O1 or optionally from reference point N2 to reference point N1 including the signalling wires when applicable. With the loopback applied no audio signal shall be present and the signalling condition shall be set to idle at reference point P2.

Indication on tests that can be used with loopbacks are given in annex F.

#### **9.1.3 PSTN interface**

This optional interface provides a 2-wire connection for a voiceband channel in the frequency band 300 Hz to 3 400 Hz with d.c. signalling. The A-law method of coding at 64 kbit/s is specified. This interface type is applicable to PSTN lines.

Standardization of a PSTN tributary will be considered in a future version of this ETS according to the V5 interface standards.

#### **9.1.4 Wide band (7 kHz) interface**

This optional interface provides a 4-wire connection for higher quality speech applications in the frequency band 50 Hz to 7000 Hz. The SB-ADPCM method of coding at 64 kbit/s, 56 kbit/s or 48 kbit/s is specified.

##### **9.1.4.1 Physical interface**

At reference point P a 4-wire interface with a nominal impedance of 600  $\Omega$  shall be provided in accordance with CCITT Recommendation G.722 [9], §§ 2.1.

##### **9.1.4.2 Coding**

The analogue signal shall be encoded into 64, 56 or 48 kbit/s SB-ADPCM in accordance with CCITT Recommendation G.722 [9], §§ 1.1, §§ 1.4, § 3, § 5 and § 6. The complementary decoding shall be in accordance with CCITT Recommendation G.722 [9], §§ 1.1, §§ 1.5, § 4, § 5 and § 6.

#### 9.1.4.3 Performance

Overall performance of the channel incorporating both send and receive equipments between 4-wire interfaces shall be in accordance with CCITT Recommendation G.722 [9], §§ 2.2, §§ 2.4, §§ 2.5. Appendix 2 of CCITT Recommendation G.722 [9] provides digital test sequences for the testing of the digital processing parts of the SB-ADPCM algorithm.

#### 9.1.4.4 Signalling

End to end signalling may be provided when the selected functional mode for the interface corresponds to a coding bit rate of 48 kbit/s or 56 kbit/s. The mapping of signalling information and digital encoded signal shall be in accordance with CCITT Recommendation G.725 [10] and H.221 [16].

#### 9.1.4.5 Signal at reference point M

At reference point M the tributary signal shall use one 64 kbit/s channel in each direction for the encoded analogue signal plus optional signalling.

#### 9.1.4.6 Cross connection rules

If the tributary signal is cross connected to an aggregate interface then:

- a) the signal at reference point M shall use one TS chosen from TSs 1 to 15 or 17 to 31 at reference point G;
- b) if TS 16 at reference point G is not configured for channel associated signalling or control then the signal may use TS 16 at reference point G.

#### 9.1.4.7 Configurable parameters

The following parameters shall be configurable by the EMF via reference point S9, S11, S12 or S13 in accordance with part 2 of this ETS (DE/TM-01013-3 [35]):

- a) audio signal levels;
- b) provisioning of the functional mode 64, 56 or 48 kbit/s coding rate;
- c) TS allocation at G reference point.

#### 9.1.4.8 Test functions

The following test functions shall be provided and controlled by the EMF via reference points S11, S12 or S13 in accordance with part 2 of this ETS (DE/TM-01013-3 [35]):

- a) connection of the external 4-wire circuit at reference point P to a metallic test bus;
- b) analogue loopback from reference point O2 to reference point O1 or optionally from reference point N2 to reference point N1. With the loopback applied no audio signal shall be present at reference point P2;
- c) logical loopback in accordance with figure 9a/G.722 of CCITT Recommendation G.722 [9]. With the loopback applied an all "1" signal shall be present at reference point M1 or reference point J1;
- d) logical loopback in accordance with figure 9b/G.722 of CCITT Recommendation G.722 [9]. With the loopback applied an all "1" signal shall be present at reference point M1 or reference point J1.

Indication on tests that can be used with loopbacks are given in clause 12.



## **9.2 Synchronous data interfaces**

### **9.2.1 CCITT Recommendation G.703/64 kbit/s Codirectional interface**

This optional interface provides a channel at 64 kbit/s. The channel may contain data or some other form of encoded signal.

#### **9.2.1.1 Physical interface**

The electrical characteristics of the interface at reference point P shall be in accordance with CCITT Recommendation G.703 [3], §§ 1.2.1 and with ETS 300 166 [31]. Octet timing shall be provided by the interface.

#### **9.2.1.2 Signal processing**

The interface should include a suitable buffer to allow for a phase relationship variation between the data received at the interface and the equipment internal timing. This buffer should also accommodate frequency and phase differences due to the plesiochronous relationship between two synchronized networks conforming to CCITT Recommendation G.811 [14]. Under conditions of plesiochronous working controlled octet slips shall be introduced.

#### **9.2.1.3 Performance**

The tolerance to jitter at the codirectional input shall be in accordance with CCITT Recommendation G.823 [15], §§ 3.1.1.

When the timing source is jitter free the jitter at the codirectional output shall be in accordance with CCITT Recommendation G.736 [12], §§ 6.2.1.

The jitter transfer between the 2 048 kbit/s input used for synchronization and the codirectional output shall be in accordance with CCITT Recommendation G.736 [12], §§ 6.3.3.

#### **9.2.1.4 Control signals**

No control signals are provided with this interface.

#### **9.2.1.5 Signal at reference point M**

At reference point M the tributary signal shall use one 64 kbit/s channel in each direction for the data signal.

#### **9.2.1.6 Cross connection rules**

If the tributary signal is cross connected to an aggregate interface then:

- a) the signal at reference point M shall use one TS chosen from TSs 1 to 15 or 17 to 31 at reference point G;
- b) if TS 16 at reference point G is not configured for channel associated signalling or control then the signal may use TS 16 at reference point G;
- c) bit 8 of the codirectional signal, when it is marked by a coding violation in accordance with CCITT Recommendation G.703 [3], §§ 1.2.1.1.5 and with ETS 300 166 [31], shall correspond with bit 8 of the TS at reference point G.

### 9.2.1.7 Configurable parameters

There are no parameters configurable by the EMF via reference point S11, S12 or S13. Via reference point S9, the following parameter shall be configurable:

- a) TS allocation at G reference point.

### 9.2.1.8 Test functions

The following test functions shall be provided and controlled by the EMF via reference points S11, S12 or S13 in accordance with part 2 of this ETS (DE/TM-01013-3 [35]):

- a) logical loopback from reference point O2 to reference point O1 or optionally from reference point N2 to reference point N1. This loopback is equivalent to loopback 2b as defined in CCITT Recommendation X.150 [26], §§ 3.4.1. With the loopback applied an all "1" signal shall be present at reference point P2;
- b) logical loopback from reference point N1 to reference point N2 or optionally from reference point M1 to reference point M2. This loopback is equivalent to loopback 3b as defined in CCITT Recommendation X.150 [26], §§ 3.2.3. With the loopback applied an all "1" signal shall be present at reference point M1 or reference point J1.

More information on the position and use of loopbacks for data channels is given in annex C. Indication on tests that can be used with loopbacks are given in annex F.

## 9.2.2 CCITT Recommendation X.24 interface

This optional interface provides a data channel at  $n \times 64$  kbit/s ( $n = 1$  to 31) with interchange circuits in accordance with CCITT Recommendation X.24 [28]. The interface shall operate as a data circuit-terminating equipment (DCE). This tributary interface may be used for the provision of a clear  $n \times 64$  kbit/s data channel, of an CCITT Recommendation X.21 [27] leased circuit or of a clear  $n \times 64$  kbit/s data channel with C/I signalling channel.

An optional requirement for the CCITT Recommendation X.24 [28] tributary interface is described in annex A.

### 9.2.2.1 Physical interface

At Reference point P the interface circuits provided shall be in accordance with table 2. The definition of these circuits can be found in CCITT Recommendation X.24 [28].

The electrical characteristics of the interchange circuits shall be in accordance with CCITT Recommendation X.27 [29].

The 15-pin interface connector type and pin assignment shall be in accordance with ISO 4903 [34].

**Table 2: CCITT Recommendation X.24 [28] interface circuits**

Designation	Function	Direction
G	Signal ground or common return	-
T	Transmit	DTE --> DCE
R	Receive	DCE --> DTE
C	Control	DTE --> DCE
I	Indication	DCE --> DTE
S	Signal element timing	DCE --> DTE
B (notes 1 and 2)	Byte timing	DCE --> DTE
X (notes 1, 2 and 3)	DTE signal element timing	DTE --> DCE
NOTE 1: Where required.		
NOTE 2: B and X circuits are exclusive, the use of the X circuit is not recommended.		
NOTE 3: The signal from X circuit cannot be selected as a candidate timing signal for the FM.		

### 9.2.2.2 Signal processing

It shall be assumed that if DTE signal timing element circuit X is used it has the same frequency as signal timing element circuit S. An input buffer shall be provided to allow for differences in phase.

### 9.2.2.3 Performance

No performance parameters are standardized.

### 9.2.2.4 Control signals

The method for transferring control information at reference point M, if required, is not standardized. For information, annex E describes two possible methods providing this function.

### 9.2.2.5 Signal at reference point M

At reference point M the tributary signal shall use  $n \times 64$  kbit/s channels in each direction for the data signal. When the method described in clause E.1 of annex E is implemented, the signal at reference point M shall use up to  $4 \times 500$  bit/s additional associated control channels in each direction for the encoded control information.

### 9.2.2.6 Cross connection rules

If the tributary signal is cross connected to an aggregate interface then:

- a) the signal at reference point M shall use  $n$  TSs chosen from any free TSs 1 to 15 or 17 to 31 at Reference G;
- b) if TS 16 at reference point G is not configured for channel associated signalling or control then part of the signal may use TS 16 at reference point G;
- c) if byte timing is provided at the data interface then data bit 8, identified in accordance with CCITT Recommendation X.24 [28], §§ 3.7, shall correspond with bit 8 of the TS at reference point G;
- d) if TS 16 at reference point G is configured for channel associated signalling or control then the  $4 \times 500$  bit/s control channels shall be cross connected in correspondance with their related TSs.

### 9.2.2.7 Configurable parameters

The following parameters shall be configurable by the EMF via reference point S9, S11, S12 or S13 in accordance with part 2 of this ETS (DE/TM-01013-3 [35]):

- a) the bit rate;
- b) TS allocation at G reference point;
- c) control signals C & I in use/not in use;
- d) selection of the mode of operation for C/I (see subclause 9.2.2);
- e) application of permanent ON or OFF condition on any control circuit;
- f) selection of the particular condition to apply to control and/or data circuits at the P2 reference point in case of defect or failure condition or in case of the activation of loopback 2b;
- g) provisioning of interface circuit B or X;
- h) DTE control of loopback 3c allowed/not allowed.

### 9.2.2.8 Test functions

The following test functions shall be provided:

- a) loopback 2b as defined in CCITT Recommendation X.150 [26], §§ 3.4.1. This logical loopback shall be from reference point O2 to reference point O1 or optionally from reference point N2 to reference point N1. With the loopback applied, the status of the circuits at reference point P shall be that configured according to subclause 9.2.2.7 f);
- b) loopback 3c as defined in CCITT Recommendation X.150 [26], §§ 3.2.2. Loopback 3c shall be implemented in such a manner that it is possible to apply and use loopback 2b and loopback 3c at the same time. Logical loopback 3c shall be from reference point O1 to reference point O2 or optionally from reference point N1 to reference point N2. With the loopback applied an all "1" data signal and an "OFF" condition on any control channel in operation shall be present at reference point M1 or reference point J1.

It shall be possible to control the application and removal of the loopbacks by the following method:

- loopbacks 2b and 3c by management control via reference points S11, S12 or S13 in accordance with part 2 of this ETS (DE/TM-01013-3 [35]).

Optionally, loopback 3c shall be under DTE control in accordance with CCITT Recommendation X.21 [27], §§ 7.2.5, §§ 7.2.5.1 to §§ 7.2.5.6 and §§7.5.

More information on the position and use of loopbacks for data channels is given in annex C. Indication on tests that can be used with loopbacks are given in annex F.

### 9.2.3 CCITT Recommendation V.24 (V.10 and V.11) interface

This optional interface provides a data channel at  $n \times 64$  kbit/s ( $n = 1$  to 31) with interchange circuits in accordance with CCITT Recommendation V.24 [21]. The interface shall operate as a Data Circuit-terminating Equipment (DCE).

An interface with electrical characteristics in accordance with CCITT Recommendation V.35 (1984) [22] is not specified. In accordance with CCITT Recommendation V.35 (1988) [23] interworking of the FM with DTE having interface circuits in accordance with CCITT Recommendation V.35 (1984) [22] can be achieved. Information on interworking of electrical interfaces in accordance with CCITT Recommendation V.35 (1984) [22] and CCITT Recommendation V.11 [19] can be found in CCITT Recommendation V.11 [19], § A.3.

An optional requirement for the CCITT Recommendation V.24 [21] tributary interface is described in annex A.

### 9.2.3.1 Physical interface

At reference point P the interface circuits provided shall be in accordance with table 3. The definition of these circuits can be found in CCITT Recommendation V.24 [21].

The electrical characteristics of the interchange circuits shall be in accordance with the following:

- a) for circuits 103, 104, 113, 114 and 115, both the generators and receivers shall be in accordance with CCITT Recommendation V.11 [19];
- b) for circuits 105, 106, 107 and 109 the generators shall be in accordance with CCITT Recommendation V.10 [18] or CCITT Recommendation V.11 [19]. The receivers shall be in accordance with CCITT Recommendation V.10 [18] category 1 or CCITT Recommendation V.11 [19] without termination;
- c) for all other circuits the generators shall be in accordance with CCITT Recommendation V.10 [18] and the receivers in accordance with CCITT Recommendation V.10 [18] category 2.

The interface connector type and pin assignment should be in accordance with the 37-pin ISO 4902 connector or with the 26-pin ISO 11569 connector.

**Table 3: CCITT Recommendation V.24 [21] interface circuits**

Designation	Function	Direction
102	Signal ground or common return	-
102a (note 1)	DTE common return	DTE --> DCE
102b (note 1)	DCE common return	DCE --> DTE
103	Transmitted data	DTE --> DCE
104	Received data	DCE --> DTE
105	Request to send	DTE --> DCE
106	Ready for sending	DCE --> DTE
107	Data set ready	DCE --> DTE
109	Data channel received line signal detector	DCE --> DTE
113 (notes 2 and 3)	Transmitter signal element timing (DTE)	DTE --> DCE
114	Transmitter signal element timing (DCE)	DCE --> DTE
115	Receiver signal element timing (DCE)	DCE --> DTE
140	Loopback / Maintenance test	DTE --> DCE
141	Local loopback	DTE --> DCE
142	Test indicator	DCE --> DTE
NOTE 1:	Required only if any interchange circuit uses CCITT Recommendation V.10 [18].	
NOTE 2:	Where required. The use of the 113 circuit is not recommended.	
NOTE 3:	The signal from 113 circuit cannot be selected as a candidate timing signal for the FM.	

### 9.2.3.2 Signal processing

It shall be assumed that if transmitter signal element timing (DTE) circuit 113 is used it has the same frequency as receiver signal element timing circuit 115. An input buffer shall be provided to allow for differences in phase.

### 9.2.3.3 Performance

No performance parameters are standardized.

### 9.2.3.4 Control signals

The method for transferring control information at reference point M, if required, is not standardized. For information, annex E describes two possible methods providing this function of transferring control information corresponding to the status of preselected circuits from the interface.

### 9.2.3.5 Signal at reference point M

At reference point M the tributary signal shall use  $n \times 64$  kbit/s channels in each direction for the data signal. When the method described in clause E.1 of annex E is implemented, the signal at reference point M shall use up to  $4 \times 500$  bit/s additional associated control channels in each direction for the encoded control information.

### 9.2.3.6 Cross connection rules

If the tributary signal is cross connected to an aggregate interface then:

- a) the data signal at reference point M shall use  $n$  TSs chosen from any free TSs 1 to 15 or 17 to 31 at reference point G;
- b) if TS 16 at reference point G is not configured for channel associated signalling or control then part of the data signal may use TS 16 at reference point G;
- c) if TS 16 at reference point G is configured for channel associated signalling or control then the  $4 \times 500$  bit/s control channels shall be cross connected in correspondance with their related TSs.

### 9.2.3.7 Configurable parameters

The following parameters shall be configurable by the EMF via reference point S9, S11, S12 or S13 in accordance with part 2 of this ETS (DE/TM-01013-3 [35]):

- a) the bit rate;
- b) any individual control signals in use/not in use;
- c) transmitter timing signal 114 or 113 in use;
- d) application of permanent ON or OFF condition on any control circuit;
- e) DTE control of loopback 3 allowed/not allowed;
- f) selection of any control signal to be transferred;
- g) TS allocation at reference point G;
- h) selection of a data pattern to be applied on 104 circuit and/or selection of a condition to be applied on control circuits at the P2 reference point in case of defect or failure condition.

### 9.2.3.8 Test functions

The following test functions shall be provided:

- a) loopback 2 as defined in CCITT Recommendation V.54 [25], §§ 3.3. This logical loopback shall be from reference point O2 to reference point O1 or optionally from reference point N2 to reference point N1. With the loopback applied, the status of the circuits at reference point P shall be according to CCITT Recommendation V.54 [25], § 4;
- b) loopback 3 as defined in CCITT Recommendation V.54 [25], §§ 3.2. Loopback 3 should be implemented in such a manner that it is possible to apply and use loopback 2 and loopback 3 at the same time. Logical loopback 3 shall be from reference point O1 to reference point O2 or optionally from reference point N1 to reference point N2. With the loopback applied an all "1" data signal and an "OFF" condition on any control channel in operation shall be present at reference point M1 or reference point J1.

The position of loopbacks 2 and 3 shall correspond to loopbacks 2b and 3c as defined in CCITT Recommendation X.150 [26], §§ 3.4.1 and §§ 3.2.2.

It shall be possible to control the application and removal of the loopbacks by the following method:

- a) loopbacks 2 and 3 by management control via reference points S11, S12 or S13 in accordance with part 2 of this ETS (DE/TM-01013-3 [35]).

Optionally loopback 3 shall be under DTE control by using circuit 141 in accordance with CCITT Recommendation V.54 [25], §§ 4.2 and loopback 2 shall be under DTE control by using circuit 140 in accordance with CCITT Recommendation V.54 [25], §§ 4.2 when the related control signal is transferred.

More information on the position and use of loopbacks for data channels is given in annex C. Indication on tests that can be used with loopbacks are given in clause 12.

#### **9.2.4 Integrated base band transmission system for data interfaces**

This optional interface allows a data interface to be provided on a Network Terminating Unit (NTU) remote from the FM equipment. The NTU is connected to the FM equipment using a baseband transmission system. The NTU, any repeater and the integrated line termination shall be considered as a sub-system of the FM. It is not precluded that the NTU provides multiple tributary interfaces.

##### **9.2.4.1 Physical interface**

The data interface provided at the NTU shall be in accordance with subclause 9.2.1.1, 9.2.2.1, or 9.2.3.1, as required.

The base band transmission system used between the NTU and the FM equipment may be standardized in a future version of this ETS.

##### **9.2.4.2 Signal processing**

Signal processing, as appropriate to the data interface type, shall be provided in accordance with subclause 9.2.1.2, 9.2.2.2, or 9.2.3.2.

##### **9.2.4.3 Performance**

No performance parameters are standardized.

##### **9.2.4.4 Control signals**

Control signal processing, as appropriate to the data interface type, shall be provided in accordance with subclause 9.2.2.4, or 9.2.3.4.

#### **9.2.4.5 Signal at reference point M**

The signal at reference point M, as appropriate to the data interface type, shall be in accordance with subclause 9.2.1.5, 9.2.2.5, or 9.2.3.5.

#### **9.2.4.6 Cross connection rules**

The cross connection rules, as appropriate to the data interface type, shall be in accordance with subclause 9.2.1.6, 9.2.2.6, or 9.2.3.6.

#### **9.2.4.7 Configurable parameters**

Configurable parameters, as appropriate to the data interface type, shall be in accordance with subclause 9.2.1.7, 9.2.2.7, or 9.2.3.7.

#### **9.2.4.8 Test functions**

Test functions at the NTU, as appropriate to the data interface type, shall be in accordance with subclause 9.2.1.8, 9.2.2.8, or 9.2.3.8.

### **9.3 CCITT Recommendation G.704 formatted n x 64 kbit/s signal interface**

This optional interface provides either an n x 64 kbit/s signal (n = 1 to 31) channel, application 1 for the interface or, an n x 64 kbit/s signal (n = 1 to 30) and channel associated signalling in TS 16, application 2 for the interface, within a 2 048 kbit/s frame in accordance with CCITT Recommendation G.704 [4] and with ETS 300 167 [35]. Application 1 covers the case where TS 16 is used to support common channel signalling.

For application 1, the traffic TSs at reference point O shall be either:

- TS 1 to TS n or TS 1 to TS n-1 + TS 16 if n < 16; or
- TS 1 to TS n if n >= 16.

For application 2, the traffic TSs at reference point O shall be the n first TSs excluding TS 16 and starting from TS 1 up to TS n or TS n+1, considering n < 16 or n >= 16 respectively. TS 16 supports the multiframe signalling structure according to CCITT Recommendation G.704 [4], §§ 5.1.3.2. In both applications, the n x 64 kbit/s signal is to be considered as from a single channel and, consequently, it shall be mapped on a single aggregate signal.

#### **9.3.1 Physical interface**

The electrical characteristics of the interface at reference point P shall be in accordance with CCITT Recommendation G.703 [3], § 6 and with ETS 300 166 [31]. The 75 Ω coaxial pair option, or 120 Ω symmetrical pair option, should be provided as required by the application.

#### **9.3.2 Signal processing**

The loss and recovery of frame alignment and CRC procedures shall be in accordance with CCITT Recommendation G.706 [5], § 4 and with ETS 300 167 [35].

If channel associated signalling is provided in TS 16, application 2, then loss and recovery of multiframe alignment shall be in accordance with CCITT Recommendation G.732 [11], §§ 5.2.

The function shall pass the n x 64 kbit/s signal transparently. This includes, in case of application 2, the n x 4 x 500 bit/s channel associated signalling or channel associated control signals in TS 16. The embedded operations channel in TS 0, if provided, shall be passed to the Message Communications Function via reference point U3.



The function shall include a suitable buffer to allow for a phase relationship variation between the data received at reference point P1 and the equipment internal timing. This buffer shall also accommodate frequency and phase differences due to the plesiochronous relationship between two synchronized networks conforming to CCITT Recommendation G.811 [14]. Under conditions of plesiochronous working controlled frame slips shall be introduced but loss of frame alignment shall not occur.

### **9.3.3 Performance**

The output jitter when the timing source is jitter free shall be in accordance with CCITT Recommendation G.736 [12], §§ 6.1.

The input jitter tolerance shall be in accordance with CCITT Recommendation G.823 [15], §§ 3.1.1.

The jitter transfer between the input used for synchronization and the tributary output at reference point P2 shall be in accordance with CCITT Recommendation G.736 [12], §§ 6.3.1 and §§ 6.3.2 with the 40 Hz cut-off option.

### **9.3.4 Control signals**

No control signals are provided with the signal at reference point P.

### **9.3.5 Signal at reference point M**

At reference point M each  $n \times 64$  kbit/s signal shall use  $n \times 64$  kbit/s channels in each direction. In addition each signal may use additional  $n \times 4 \times 500$  bit/s channels in each direction for its channel associated signalling or control.

### **9.3.6 Cross connection rules**

If the tributary signal is cross connected to an aggregate interface then:

- a) the signal at reference point M shall use any  $n$  free TSs chosen from any free TSs 1 to 15 or 17 to 31 at reference point G;
- b) if TS 16 at reference point G is not configured for channel associated signalling or control then part of the signal may use TS 16 at reference point G;
- c) TS sequence integrity shall be maintained between reference point O and reference point G for each signal;
- d) if the  $n \times 64$  kbit/s signal has a channel associated signalling or control at reference point M it shall use the corresponding a, b, c and d bits in TS 16 at reference point G.

### **9.3.7 Configurable parameters**

The following parameters shall be configurable by the EMF via reference point S9, S11, S12 or S13 in accordance with part 2 of this ETS (DE/TM-01013-3 [35]):

- a) the value of  $n$  from 1 to 31 for the signal;
- b) concatenation information about the TSs belonging to the same  $n \times 64$  kbit/s signal;
- c) use of TS 16 for channel associated signalling or for a user signal (selection of the application for the tributary interface);
- d) selection of TS arrangement at tributary and aggregate interfaces.

9.3.8 Test functions

The following test functions shall be provided and controlled by the EMF via reference points S11, S12 or S13 in accordance with part 2 of this ETS (DE/TM-01013-3 [35]):

- logical loopback of the complete 2 048 kbit/s signal from reference point O2 to reference point O1. With the loopback applied AIS shall be sent at reference point P2. The description of this loopback is given in figure 6.

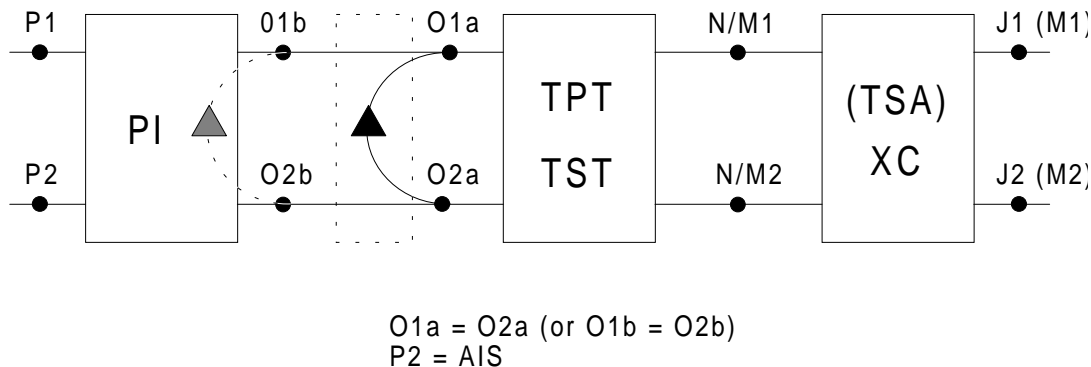

Figure 6

The following loopback/test function (line loopback) for the purpose of transmission section testing is an option for the equipment may be provided via reference point S11, S12 or S13 in accordance with part 2 of this ETS (DE/TM-01013-3 [35]):

- logical loopback from reference point O1 to reference point O2 of the complete 2 048 kbit/s signal. With the loopback applied an all "1" signal shall be present on the corresponding signals at reference point M1 or reference point J1. The description of this loopback is given in figure 7.

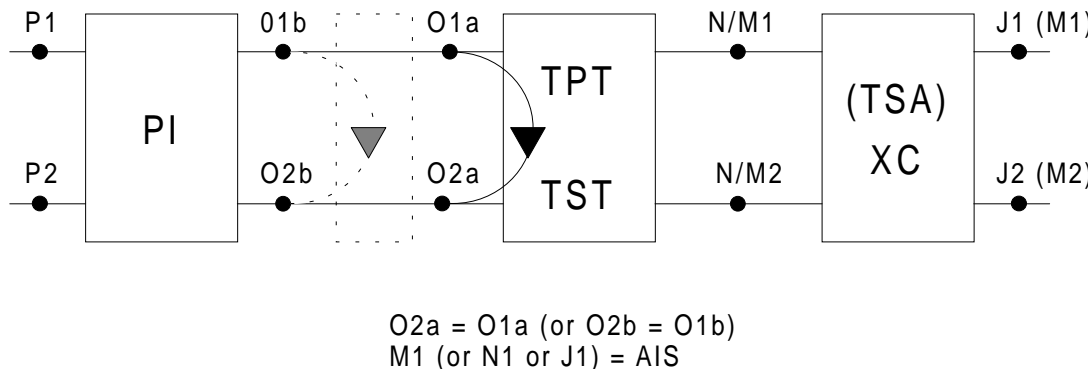

Figure 7

Indication on tests that can be used with loopbacks are given in annex F.

9.4 ISDN tributary interfaces

These interfaces are provided for ISDN primary rate and basic access. The reference model for ISDN tributary interfaces will be considered in a future version of this ETS according to the V5 interface standards.

## **9.5 CCITT Recommendation G.703/2 048 kbit/s unstructured interface**

These optional interface provides access to 2 048 kbit/s ONP Leased Line or to any structured signal for applications that do not allow intermediate path termination function.

Signals going through the FM are not synchronized by the MTS functional block. This allows the transfer of plesiochronous 2 048 kbit/s signals.

This interface gives direct access to reference point G (or B) for 2 048 kbit/s logical signal.

### **9.5.1 Physical interface**

The electrical characteristics of the interface at reference point P shall be in accordance with CCITT Recommendation G.703 [3], § 6 and with ETS 300 166 [31]. The 75  $\Omega$  coaxial pair option, or 120  $\Omega$  symmetrical pair option, should be provided as required by the application. Signal at reference point P2 is synchronized by signal at reference point X2. Reference point X1 represents timing signal recovered from signal at P1 reference point.

### **9.5.2 Signal processing**

There is no signal processing required for this tributary interface.

### **9.5.3 Performance**

The output jitter when the timing source is jitter free shall be in accordance with CCITT Recommendation G.736 [12], §§ 6.1.

The input jitter tolerance shall be in accordance with CCITT Recommendation G.823 [15], §§ 3.1.1.

### **9.5.4 Control signals**

No control signals are provided with the signal at reference point P.

### **9.5.5 Signal at reference point G**

The signal at reference point G1 (or B1) is a 2 048 kbit/s unstructured logical signal synchronous to signal present at reference point X1. The signal at reference point G2 (or B2) is a 2 048 kbit/s unstructured logical signal synchronous to signal present at reference point X2. Both signals at reference points G2 and X2 are delivered either from a CCITT Recommendation G.703 [3]/2 048 kbit/s aggregate PI functional block (directly or via a LSPSW functional block) or by a higher order multiplexing function.

### **9.5.6 Cross connection rule**

There is no cross connection rule attached to this tributary interface.

### **9.5.7 Configurable parameters**

There is no parameter configurable by the EMF via reference point S14.

### **9.5.8 Test functions**

The following test functions may be optionally provided and controlled by the EMF via reference point S14 in accordance with part 2 of this ETS (DE/TM-01013-3 [35]):

- logical loopback of the complete 2 048 kbit/s signal from reference point O2 to reference point O1. With the loopback applied, AIS shall be sent at reference point P2.

Indication on tests that can be used with loopbacks are given in annex F.

## **10 Defect or failure conditions and consequent actions**

### **10.1 Defect or failure conditions in the core functions and consequent actions at reference points J1 and M2**

#### **10.1.1 Defect or failure conditions in the core functions**

The core function of the FM shall detect the defect or failure conditions in subclauses 10.1.1.1 and 10.1.1.2.

##### **10.1.1.1 Power supply failure**

This defect or failure condition should be detected on total loss of power to the equipment.

##### **10.1.1.2 Loss of synchronization references**

The equipment shall detect loss of a single external synchronization reference under the following conditions:

- a) for a synchronization reference in accordance with subclause 7.2(a):
  - loss of signal;
- b) for a synchronization reference in accordance with subclause 7.2 b) and 7.2 c):
  - 1) loss of signal in accordance with subclause 10.2.1;
  - 2) loss of frame alignment in accordance with subclause 10.3.1.1;
  - 3) excessive bit error ratio in accordance with subclause 10.3.1.2. Detection of this condition is optional;
  - 4) loss of synchronization in a remote equipment, defect indication in accordance with subclause 10.3.1.3 c). Detection of this condition is optional;
  - 5) reception of alarm indication signal in accordance with subclause 10.3.1.4.

Loss of synchronization references shall be detected when all the external synchronization references indicated in subclauses 7.2 a), 7.2 b) and 7.2 c) have failed.

#### **10.1.2 Consequent actions at reference points J1 and M2**

Further to the detection of a defect or a failure condition, appropriate consequent actions shall be taken as specified in table 4. The consequent actions should be taken as soon as possible as follows:

- a) the application of AIS should be within 3 ms of the detection of the failure condition;
- b) the maximum period between the detection of a defect or failure condition and the transmission of a defect indication at reference point G1 should be of the order of 100 ms;
- c) the maximum period between the detection of a defect or failure condition and the generation of any failure information is dependant on the maintenance strategy for the equipment. This is specified in part 2 of this ETS (DE/TM-01013-3 [35]).

Table 4: Consequent actions for core functions

Defect or failure condition	Failure information generated	Consequent action	
		J1	M2
Power supply	(note 1)	AIS (note 2 and 3)	AIS (note 2 and 3)
Loss of single synchronization reference (note 5)			
Loss of synchronization references (note 5)		(note 4)	(note 4)
NOTE 1:	Defect or failure conditions are notified to the EMF via reference points S9, S10, S15, S16 or S17. Consequent actions related to the generation of failure information are specified in part 2 of this ETS (DE/TM-01013-3 [35]).		
NOTE 2:	AIS is applied to all octets including TS 16.		
NOTE 3:	If practicable.		
NOTE 4:	In order to enable appropriate action at the remote end the indication of loss of synchronization, in addition to any other defect indication, may be transmitted to the remote end. The use of the 4 kbit/s data link on Sa4 in TS 0 of the non-frame alignment signal or a free Sa bit in TS 0 of the non-frame alignment signal is suggested for this application.		
NOTE 5:	Consequently to the detection of this condition the equipment may switch to the next synchronization reference or remove from operation any of the affected synchronization references according to a predetermined synchronization strategy as specified in part 2 of this ETS (DE/TM-01013-3 [35]).		

## 10.2 Defects or failures at reference points A2 of the 2 048 kbit/s CCITT Recommendation G.703 aggregate Physical Interface and consequent actions at reference points A1 and B2 (or G2)

### 10.2.1 Defect or failure conditions at reference points A2 or A1 of the 2 048 kbit/s CCITT Recommendation G.703 aggregate Physical Interface

The 2 048 kbit/s CCITT Recommendation G.703 [3] aggregate Physical Interface function of the FM shall detect the following defect or failure conditions:

- a) Loss Of incoming aggregate Signal (LOS).

NOTE: The detection of this defect or failure condition is required only when it does not result in an indication of loss of frame alignment or if the LSPSW function is provided.

A loss of incoming signal defect at 2 048 kbit/s interfaces shall be detected if the incoming signal has "no transitions" for a consecutive number of pulse positions N, where  $X \leq N \leq Y$ , see figure 8.

The LOS defect shall be cleared if the incoming signal has "no transition-free intervals" for a consecutive number of pulse positions N', where  $X' \leq N' \leq Y'$ .

A signal with "no transition-free intervals" corresponds to a CCITT Recommendation G.703 [3] compliant signal. The criteria for detection of "no transition" condition and "transition" condition is indicated in figure 9.

Values for X, Y, X', Y' and Q are given in table 5.

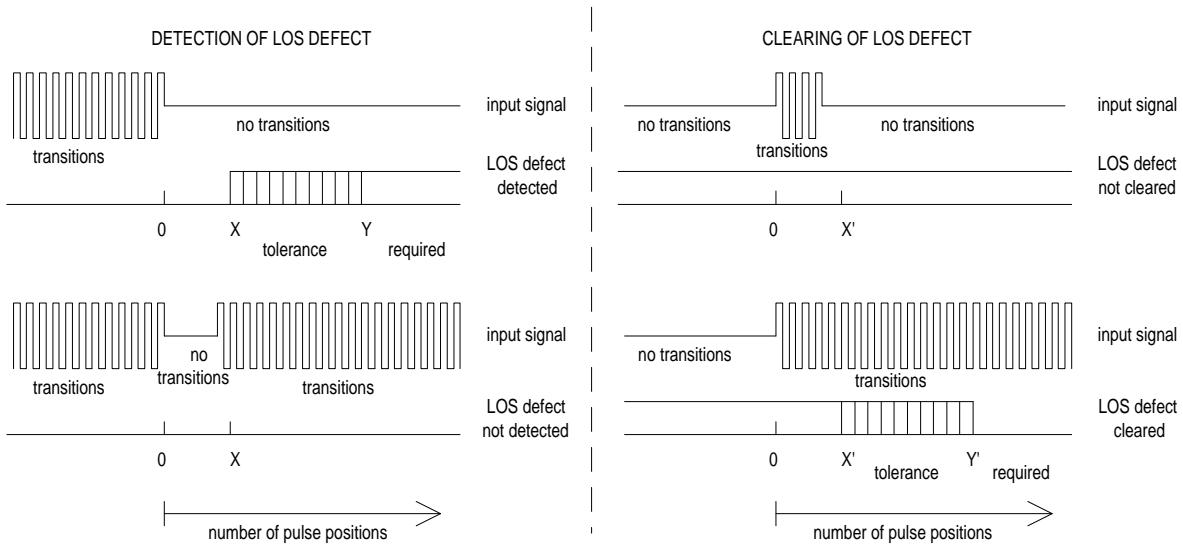

**Figure 8: Timing of LOS defect detection and clearing**

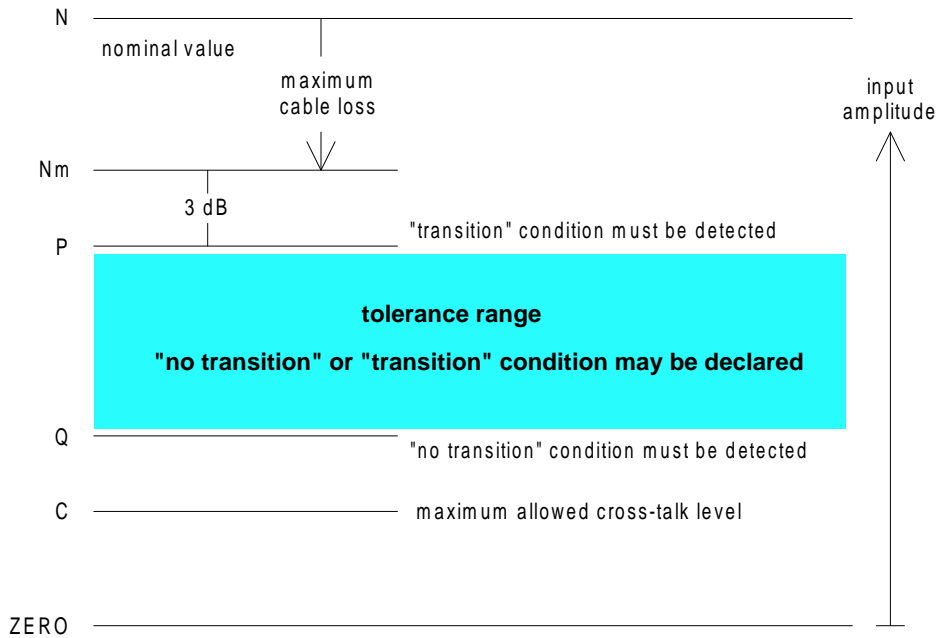

NOTE: The "no transition" shall be detected if the signal level is at level "Q" or below, the "transition" condition shall be declared at the level "P" or above.

**Figure 9: Criteria for determination of transition conditions**

**Table 5: LOS defect criteria**

Bit rate (kbit/s)	Pulse time (ns)	X (number of pulses)	Y (number of pulses)	X' (number of pulses)	Y' (number of pulses)	Q (dB)
2 048	488,28	10	255	10	255	35

b) Bipolar violation error.

Bipolar violation errors anomaly events should be detected in order to allow performance monitoring for the digital section. If requested, this function should comply with part 2 of this ETS (DE/TM-01013-3 [35]).

### 10.2.2 Consequent actions at reference points A1 and B2 (or G2)

Further to the detection of the loss of incoming aggregate 2 048 kbit/s signal, appropriate consequent actions shall be taken as specified in table 6. If the LSPSW function is not provided then the consequent actions specified for reference point B2 shall be performed at reference point G2. The consequent actions should be taken as soon as possible as follows:

- a) the application of AIS should be within 3 ms of the detection of the failure condition;
- b) the maximum period between the detection of a defect or failure condition and the transmission of a defect indication at reference point A1 should be of the order of 100 ms;
- c) the maximum period between the detection of a defect or failure condition and the generation of any failure information is dependant on the maintenance strategy for the equipment. This is specified in part 2 of this ETS (DE/TM-01013-3 [35]).

**Table 6: Consequent actions for 2 048 kbit/s CCITT Recommendation G.703 [3] physical interface**

Defect or failure condition	Failure information generated	Consequent action	
		A1	B2 (or G2)
Loss of incoming signal	(note 1)	RAI (note 2)	AIS (note 3)
Bipolar violation error (note 4)	(note 1)		
NOTE 1: Defect or failure conditions are notified to the EMF via reference point S1. Consequent actions related to the generation of failure information are specified in part 2 of this ETS (DE/TM-01013-3 [35]).			
NOTE 2: RAI, Remote Alarm Indication in bit 3 of TS 0 of the non-frame alignment signal set to 1 when the aggregate signal is structured according to CCITT Recommendation G.704 [4].			
NOTE 3: This applies to reference point G2 when no LSPSW function is in operation or if the condition occurs on the stand-by section this being in operation.			
NOTE 4: Where required.			

### 10.3 Defects or failures at reference points G2 and consequent actions at reference points G1 and H2 (or J2)

#### 10.3.1 Defect or failure conditions at reference points G2

The 2 048 kbit/s path termination function shall detect the following defect or failure conditions:

##### 10.3.1.1 Loss of frame alignment

The detection of this defect shall be in accordance with CCITT Recommendation G.706 [5], §§ 4.1. According to the CRC4 procedure, a failure of the CRC4 multiframe alignment should also lead to the detection of loss of frame alignment in accordance with CCITT Recommendation G.706 [5], §§ 4.3.2.

##### 10.3.1.2 Excessive bit error ratio

The detection of this defect shall be in accordance with CCITT Recommendation G.736 [12], §§ 4.1.5.

The detection of this defect is optional. When required, it can be determined by counting either the number of frame alignment words in error or the number of bits in the frame alignment word in error or by using the CRC4 procedure. Details are given in part 2 of this ETS (DE/TM-01013-3 [35]).

### 10.3.1.3 Defect indications from a remote equipment in TS 0

The equipment shall detect the following defect indications from the remote equipment:

- a) remote alarm indication, bit 3 of TS 0 of the non-frame alignment signal (bit A) set to "1";
- b) remote AIS defect indication (note);
- c) remote synchronization failure indication (note).

NOTE: Detection of these defect and failure indications is only required where they are provided from the remote equipment. In existing networks the bits Sa5, Sa6 or Sa7 may be used for this purpose. To enable appropriate action at the remote end, it is recommended that the defect or failure indications are transmitted to the remote end by the use of the 4 kbit/s data link on Sa4 in TS 0 of the NFAS.

### 10.3.1.4 Reception of alarm indication signal

The detection of AIS shall be in accordance with the following:

The AIS defect in 2 048 kbit/s signal shall be detected if the incoming signal has X or less ZEROs in each of two consecutive Y-bit periods.

The defect shall be cleared if each of two consecutive Y-bit periods contains Z or more ZEROs or the frame alignment signal (FAS) has been found.

The values of X, Y and Z are specified in the table 7.

**Table 7: AIS signal defect detection and clearing criteria**

Bit rate (kbit/s)	X (number of ZEROs)	Y (bits)	Z (number of ZEROs)	frame structure	bits/frame
2 048	2	512	3	G.704 [4]	256

### 10.3.1.5 Loss of multiframe alignment

When TS 16 is used for channel associated signalling or control the detection of this defect shall be in accordance with CCITT Recommendation G.732 [11], §§ 5.2.

### 10.3.1.6 Defect indication from a remote equipment in TS 16

When TS 16 is used for channel associated signalling or control this defect shall be detected as follows:

- remote alarm indication in bit 6 of TS 16 frame 0 of the multiframe set to "1".

### 10.3.1.7 Reception of alarm indication signal in TS 16

When TS 16 is used for channel associated signalling or control the reception of alarm indication signal in TS 16 shall be detected.

An AIS condition is determined when the incoming signal in TS 16 has three or less ZEROs in each of two consecutive CAS multiframe periods.

The defect is cleared if each of two consecutive CAS multiframe periods contains four or more ZEROs or if the multiframe alignment has been found.



#### **10.3.1.8 Frame slip**

This defect occurs when the received signal is not synchronous to the internal timing of the equipment. The re-alignment of the signal shall be based on controlled frame slips which shall not imply a loss of frame alignment condition.

#### **10.3.1.9 CRC4 block error**

This condition shall be detected when the CRC4 procedure is activated.

#### **10.3.1.10 Remote CRC4 block error**

This condition corresponding to the detection of a CRC4 block error at the remote end shall be detected when the CRC4 procedure is activated.

### **10.3.2 Consequent actions at reference points G1 and H2 (or J2)**

Further to the detection of a defect or a failure condition, appropriate consequent actions shall be taken as specified in table 8. If the LPPSW function is not provided then the consequent actions specified for reference point H2 shall be performed at reference point J2. If TS 16 is used for channel associated signalling or control appropriate consequent actions shall also be taken as specified in table 9. The consequent actions should be taken as soon as possible as follows:

- a) the application of AIS should be within 2 ms of the detection of the failure condition;
- b) the maximum period between the detection of a defect or failure condition and the transmission of a defect indication at reference point G1 should be of the order of 100 ms;
- c) the maximum period between the detection of a defect or failure condition and the generation of any failure information is dependant on the maintenance strategy for the equipment. This is specified in part 2 of this ETS (DE/TM-01013-3 [35]).

**Table 8: Consequent actions for the PLPT**

Defect or failure condition	Failure information generated	Consequent action	
		G1	H2 (or J2)
Loss of frame alignment	(note 1)	RAI (note 3)	AIS
Excessive bit error ratio (note 4)		RAI (note 3)	AIS (note 2)
RAI from remote end			
AIS received		RAI (note 5 and 6)	AIS
Remote AIS indication (note 7)			
Frame slip			
CRC4 block error		E (note 8)	
Remote CRC4 block error			
NOTE 1: Defect or failure conditions are notified to the EMF via reference point S6. Consequent actions related to the generation of failure information are specified in part 2 of this ETS (DE/TM-01013-3 [35]). NOTE 2: Provision shall be made for disabling this action. NOTE 3: RAI, Remote Alarm Indication bit 3 in TS 0 of the non-frame alignment signal set to 1. NOTE 4: The detection of this defect condition is optional. NOTE 5: In order to enable appropriate action at the remote end the indication of the reception of AIS, in addition to any other defect indication, may be transmitted to the remote end. The use of the 4 kbit/s data link on Sa4 of TS 0 of the non-frame alignment signal or the use of a spare Sa bit in TS 0 of the non-frame alignment signal is suggested for this application. NOTE 6: This consequent action is optional. NOTE 7: If provided, see note 5. NOTE 8: "E" Indication to the remote end of the reception of an errored CRC4 block, set to 0 according to the CRC4 procedure.			

**Table 9: Additional consequent actions for the PLPT with CAS**

Defect or failure condition	Failure information generated	Consequent action	
		G1	H2 (or J2)
Loss of multiframe alignment	(note 1)	RAI (note 3)	AIS (note 2)
RAI from remote end			
AIS received in TS 16		RAI (note 3)	AIS (note 2)
NOTE 1: Defect or failure conditions are notified to the EMF via reference point S6. Consequent actions related to the generation of failure information are specified in part 2 of this ETS (DE/TM-01013-3 [35]). NOTE 2: AIS applied to signal corresponding to TS 16. NOTE 3: RAI, Remote Alarm Indication in bit 6 of TS 16 frame 0 of the multiframe set to "1".			

NOTE: To tables 8 and 9:  
 consequent actions at G1 reference point apply also to situations where the LPPSW function is in operation. Consequent actions at J2 reference point only apply when defect or failure conditions are detected on both 2 048 kbit/s paths.

**10.4 Defects or failures at reference points P1 or P2 and consequent actions at reference points P2 and M1 (or J1)**

**10.4.1 Defects or failure conditions at reference points P1 or P2**

The equipment shall detect when a tributary interface is not equipped and also the following defects or failure conditions according to the tributary types provided.

**10.4.1.1 2-wire/4-wire voice band (3 400 Hz) interface**

No failure conditions are specified for this interface.

**10.4.1.2 2-wire/4-wire voice band (3 400 Hz) with d.c. signalling interface**

No failure conditions are specified for this interface.

Particular specifications for signalling defect or failure conditions should be determined by individual administrations.

**10.4.1.3 PSTN interface**

See subclause 9.1.3.

**10.4.1.4 Wide band interface (7 kHz)**

No failure conditions are specified for this interface.

**10.4.1.5 CCITT Recommendation G.703/64 kbit/s codirectional interface**

The equipment shall detect the following conditions:

- a) Loss of signal at reference point P1;
- b) Loss of octet timing at reference point P1. The detection of this defect is optional.

A loss of incoming signal defect at 64 kbit/s interfaces shall be detected if the incoming signal has "no transitions" for a consecutive number of pulse positions N, where  $X \leq N \leq Y$ , see figure 8.

The LOS defect shall be cleared if the incoming signal has "no transition-free intervals" for a consecutive number of pulse positions N', where  $X' \leq N' \leq Y'$ .

A signal with "no transition-free intervals" corresponds to a CCITT Recommendation G.703 [3] compliant signal. The criteria for detection of "no transition" condition and "transition" condition is indicated in figure 9.

Values for X, Y, X', Y' and Q are given in the table 10.

**Table 10: LOS defect criteria**

Bit rate (kbit/s)	Pulse time (ns)	X (number of pulses)	Y (number of pulses)	X' (number of pulses)	Y' (number of pulses)	Q (dB)
64	3 906,25	10	255	10	255	35

**10.4.1.6 CCITT Recommendation X.24 interface**

As an option the equipment may be required to detect one or more of the following conditions in accordance with CCITT Recommendation V.11 [19], § 9:

- a) electrical failure of circuits T and C (and X if this circuit is used) at reference point P1;
- b) loss of the connection between the DTE and DCE. Detection of this defect shall be done on at least one active circuit at reference point P1;
- c) loss of power at the DTE.

#### **10.4.1.7 CCITT Recommendation V.24 (V.10 and V.11) interface**

As an option the equipment may be required to detect one or more of the following conditions in accordance with CCITT Recommendation V.10 [18], § 11 or CCITT Recommendation V.11 [19], § 9:

- a) loss of the connection between the DTE and DCE. Detection of this defect shall be done on at least one active circuit at reference point P1;
- b) loss of power at the DTE.

#### **10.4.1.8 Integrated baseband transmission system for data interfaces**

Detection of defect and failure conditions at the data interface on the NTU shall be in accordance with subclause 10.4.1.5, 10.4.1.6, or 10.4.1.7.

Specification of defect or failure conditions for the baseband transmission system are left for further consideration.

#### **10.4.1.9 CCITT Recommendation G.704 formatted n x 64 kbit/s signal interface**

The equipment shall detect the following defect and failure conditions:

- a) loss of signal in accordance with subclause 10.2.1;
- b) loss of frame alignment in accordance with subclause 10.3.1.1;
- c) excessive bit error ratio in accordance with subclause 10.3.1.2. Detection of this condition is optional;
- d) defect indication(s) from the remote equipment in TS 0 in accordance with subclause 10.3.1.3;
- e) reception of alarm indication signal in accordance with subclause 10.3.1.4;
- f) frame slip in accordance with subclause 19.3.1.8;
- g) CRC4 block error in accordance with subclause 19.3.1.9;
- h) remote CRC4 block error in accordance with subclause 19.3.1.10.

When TS 16 is used and declared for channel associated signalling or control, the equipment shall also detect the following defect and failure conditions:

- a) loss of multiframe alignment in accordance with subclause 10.3.1.5;
- b) defect indication from remote equipment in TS 16 in accordance with subclause 10.3.1.6;
- c) reception of alarm indication signal in TS 16 in accordance with subclause 10.3.1.7.

#### **10.4.1.10 ISDN interfaces**

See subclause 9.4.

#### **10.4.1.11 CCITT Recommendation G.703/2 048 kbit/s unstructured interface**

The equipment shall detect the following defect and failure condition:

- a) loss of signal in accordance with subclause 10.2.1;
- b) bipolar violation error.

Bipolar violation errors anomaly events should be detected in order to allow performance monitoring for the digital section. If requested, this function should comply with part 2 of this ETS (DE/TM-01013-3 [35]).

**10.4.2 Consequent actions at reference points P2 and M1 (or J1)**

When a tributary interface is not equipped AIS shall be presented to reference point M1 (or J1).

After the detection of a defect or failure condition, according to subclauses 10.4.1.1 to 10.4.1.11, appropriate consequent actions shall be taken as specified in the tables given in subclauses 10.4.2.1 to 10.4.2.11.

**10.4.2.1 2-wire/4-wire voice band (3 400 Hz) interface**

No consequent actions are specified for this interface.

**10.4.2.2 2-wire/4-wire voice band (3 400 Hz) with d.c. signalling interface**

See subclause 9.1.2.7.

**10.4.2.3 PSTN interface**

No consequent actions are specified for this interface.

Particular specifications for consequent actions due to signalling defect or failure conditions should be determined by individual administrations. See also subclause 9.1.3.

**10.4.2.4 Wide band interface (7 kHz)**

No consequent actions are specified for this interface.

**10.4.2.5 CCITT Recommendation G.703/64 kbit/s codirectional interface**

**Table 11: Consequent actions for a CCITT Recommendation G.703 [3]/64 kbit/s codirectional tributary**

Defect or failure condition	Failure information generated	Consequent action	
		P2	M1 (or J1)
Loss of incoming signal at reference point P1	(note 1)	ROT (note 2 and 4)	AIS (note 3)
Loss of octet timing at reference point P1			
NOTE 1: Defect or failure conditions are notified to the EMF via reference points S11, S12 or S13. Consequent actions related to the generation of failure information are specified in part 2 of this ETS (DE/TM-01013-3 [35]).			
NOTE 2: Provision shall be made for disabling this action.			
NOTE 3: When action is taken at reference point M1, AIS shall be applied within 3 ms of the detection of the relevant defect or failure condition. When action is taken at reference point J1, application of AIS is software controlled and additional delay may be needed.			
NOTE 4: ROT, Remove Octet Timing, octet timing not sent.			

10.4.2.6 CCITT Recommendation X.24 interface

Table 12: Consequent actions for CCITT Recommendation X.24 [28] tributary

Defect or failure condition	Failure information generated	Consequent action	
		P2	M1 (or J1)
Failure of circuit T	(note 1)		1/0 (note 2)
Failure of circuit C (when provided)			OFF (note 3)
Failure of circuit X			(note 5)
Loss of connection between DTE and DCE			1/0-OFF(note 2 and 4)
Loss of power at the DTE			1/0-OFF (note 2 and 4)
NOTE 1: Defect or failure conditions are notified to the EMF via reference points S11, S12 or S13. Consequent actions related to the generation of failure information are specified in part 2 of this ETS (DE/TM-01013-3 [35]).			
NOTE 2: Continuous bit stream of ONEs or ZEROs is applied depending on the configuration of the tributary interface.			
NOTE 3: An OFF condition is applied on control signal when C circuit is provided.			
NOTE 4: An OFF condition is applied on control signal when it is transferred.			
NOTE 5: The transmit signal is timed with the S signal.			

10.4.2.7 CCITT Recommendation V.24 (V.10 and V.11) interface

Table 13: Consequent actions for CCITT Recommendation V.24 [21] tributary

Defect or failure condition	Failure information generated	Consequent action	
		P2	M1 (or J1)
Loss of the connection between the DTE and DCE	(note 1)		1-OFF
Loss of power at the DTE			(note 2)
			1-OFF (note 2)
NOTE 1: Defect or failure conditions are notified to the EMF via reference points S11, S12 or S13. Consequent actions related to the generation of failure information are specified in part 2 of this ETS (DE/TM-01013-3 [35]).			
NOTE 2: All "1" applied on data signal and "OFF" condition on control signal(s) being transferred.			

10.4.2.8 Integrated baseband transmission system for data interfaces

The consequent actions after the detection of defect and failure conditions at the data interface on the NTU shall be in accordance with subclause 10.4.2.5, 10.4.2.6, or 10.4.2.7.

Specification of consequent actions for defect or failure conditions for the baseband transmission system are not the subject of standardization.

10.4.2.9 CCITT Recommendation G.704 formatted n x 64 kbit/s signal interface

Further to the detection of a defect or a failure condition, appropriate consequent actions shall be taken as specified in table 14. If TS 16 is used for channel associated signalling or control appropriate consequent actions shall also be taken as specified in table 15. The consequent actions should be taken as soon as possible as follows:

- a) the application of AIS should be within 2 ms of the detection of the failure condition;
- b) the maximum period between the detection of a defect or failure condition and the transmission of a defect indication at reference point P2 should be of the order of 100 ms;

- c) the maximum period between the detection of a defect or failure condition and the generation of any failure information is dependant on the maintenance strategy for the equipment. This is specified in part 2 of this ETS (DE/TM-01013-3 [35]).

**Table 14: Consequent actions for n x 64 kbit/s tributary**

Defect or failure condition	Failure information generated	Consequent action	
		P2	M1 (or J1)
Loss of incoming signal	(note 1)	RAI (note 3)	AIS
Loss of frame alignment		RAI (note 3)	AIS
Excessive bit error ratio (note 4)		RAI (note 3)	AIS (note 2)
RAI from remote end			
AIS received		RAI (note 5 and 6)	AIS
Remote AIS indication (note 7)			
Frame slip			
CRC4 block error		E (note 8)	
Remote CRC4 block error			
NOTE 1: Defect or failure conditions are notified to the EMF via reference points S11, S12 or S13. Consequent actions related to the generation of failure information are specified in part 2 of this ETS (DE/TM-01013-3 [35]).			
NOTE 2: Provision shall be made for disabling this action.			
NOTE 3: RAI, Remote Alarm Indication bit 3 in TS 0 of the non-frame alignment signal set to 1.			
NOTE 4: The detection of this defect condition is optional.			
NOTE 5: In order to enable appropriate action at the remote end the indication of the reception of AIS, in addition to any other defect indication, may be transmitted to the remote end. The use of the 4 kbit/s data link on Sa4 of TS 0 of the non-frame alignment signal or the use of a spare Sa bit in TS 0 of the non-frame alignment signal is suggested for this application.			
NOTE 6: This consequent action is optional.			
NOTE 7: If provided, see note 5.			
NOTE 8: "E" Indication to the remote end of the reception of an errored CRC4 block, set to 0 according to the CRC4 procedure.			

**Table 15: Additional consequent actions for tributary with CAS**

Defect or failure condition	Failure information generated	Consequent action	
		P2	M1 (or J1)
Loss of multiframe alignment	(note 1)	RAI (note 3)	AIS (note 2)
RAI from remote end			
AIS received in TS 16		RAI (note 3)	AIS (note 2)
NOTE 1: Defect or failure conditions are notified to the EMF via reference points S11, S12 or S13. Consequent actions related to the generation of failure information are specified in part 2 of this ETS (DE/TM-01013-3 [35]).			
NOTE 2: AIS applied to 4 x 500 bit/s signalling or control channels.			
NOTE 3: RAI, Remote Alarm Indication in bit 6 of TS 16 frame 0 of the multiframe set to "1".			

#### 10.4.2.10 ISDN interfaces

See subclause 9.4.

**10.4.2.11 CCITT Recommendation G.703/2 048 kbit/s unstructured interface**

Further to the detection of a defect or a failure condition, appropriate consequent actions shall be taken as specified in table 16. The consequent actions should be taken as soon as possible as follows:

- a) the application of AIS should be within 2 ms of the detection of the failure condition;
- b) the maximum period between the detection of a defect or failure condition and the generation of any failure information is dependant on the maintenance strategy for the equipment. This is specified in part 2 of this ETS (DE/TM-01013-3 [35]).

**Table 16: Consequent actions for CCITT Recommendation G.703 [3]/2 048 kbit/s unstructured tributary**

Defect or failure condition	Failure information generated	Consequent action	
		P2	G1
Loss of incoming signal	(note)		AIS
Bipolar violation error			
NOTE: Defect or failure conditions are notified to the EMF via reference points S11, S12 or S13. Consequent actions related to the generation of failure information are specified in part 2 of this ETS (DE/TM-01013-3 [35]).			

**11 Performance monitoring**

The following performance indications can be derived from error events or other defects:

- a) unavailable time;
- b) degraded performance;
- c) unacceptable performance.

The strategy for determining these quality performance parameters shall be in accordance with part 2 of this ETS (DE/TM-01013-3 [35]).

**12 Test functions**

These functions should not be standardized. See annex F for guidance.



## **Annex A (normative): Differentiating between user information and network failure indication**

This annex describes the additional requirements for both CCITT Recommendation X.24 [28] and CCITT Recommendation V.24 [21] tributary interfaces, applicable when in-band means of differentiating between user information and network failure indication is requested.

References are made to the relevant clauses or subclauses of this ETS and are indicated by parentheses in the headings. The contents of the following clauses and subclauses are intended to be added to the relevant clauses and subclauses of this ETS as part of the CCITT Recommendation X.24 [28] and CCITT Recommendation V.24 [21] tributary interfaces requirements.

### **A.1 Signal processing (subclause 9.2.2.2)**

The following text shall be added to subclause 9.2.2.2:

On bilateral agreement of network provider concerned, a self-synchronising scrambler (descrambler) and having the generating polynomial  $1 \oplus x^{-18} \oplus x^{-23}$  shall be included in the transmitter (respectively the receiver) part of the TSA functional block. The characteristics of the scrambler (respectively the descrambler) are according to CCITT Recommendation V.38 [24], §§ 3.1 (and §§ 3.2 respectively) and its use is extended to  $n \times 64$  kbit/s signals with  $n$  ranging from 1 to 31.

Where this scrambler/descrambler function is provided, the AIS condition at  $n \times 64$  kbit/s will be detected upon the reception of 256 consecutive bits in the binary ONE condition before descrambling. The consequent action to the detection of the AIS detection is the application of the  $R = 0, I = \text{OFF}$  condition at the reference point P2. The normal condition at the reference point P2 shall be restored upon the reception, before descrambling, of at least 16 bits in the binary ZERO condition in a sequence of 256 bits at  $n \times 64$  kbit/s.

### **A.2 Configurable parameters (subclause 9.2.2.7)**

The following parameter shall be added to subclause 9.2.2.7:

- i) CCITT Recommendation V.38 [24] scrambling/descrambling function in use/not in use.

### **A.3 CCITT Recommendation X.24 interface (subclause 10.4.1.6)**

The following text shall be added to subclause 10.4.1.6.

In addition, the equipment shall detect the following condition in accordance with subclause A.9.2.2.2:

- d) AIS at  $n \times 64$  kbit/s at reference point M2 when the CCITT Recommendation V.38 [24] scrambling/descrambling function is activated.

### **A.4 Signal processing (subclause 9.2.3.2)**

The following text shall be added to subclause 9.2.3.2:

On bilateral agreement of network provider concerned, a self-synchronising scrambler (descrambler) and having the generating polynomial  $1 \oplus x^{-18} \oplus x^{-23}$  shall be included in the transmitter (respectively the receiver) part of the TSA functional block. The characteristics of the scrambler (respectively the descrambler) are according to CCITT Recommendation V.38 [24], §§ 3.1 (and §§ 3.2 respectively) and its use is extended to  $n \times 64$  kbit/s signals with  $n$  ranging from 1 to 31.

Where this scrambler/descrambler function is provided, the AIS condition at  $n \times 64$  kbit/s will be detected upon the reception of 256 consecutive bits in the binary ONE condition before descrambling. The consequent action to the detection of the AIS detection is the application of the  $109 = \text{OFF}$  condition at the reference point P2. The normal condition at the reference point P2 shall be restored upon the reception, before descrambling, of at least 16 bits in the binary ZERO condition in a sequence of 256 bits at  $n \times 64$  kbit/s.

### A.5 Configurable parameters (subclause 9.2.3.7)

The following parameter shall be added to subclause 9.2.3.7:

- f) CCITT Recommendation V.38 [24] scrambling/descrambling function in use/not in use.

### A.6 CCITT Recommendation V.24(V.10 and V.11) interface (subclause 10.4.1.7)

The following text shall be added to subclause 10.4.1.7:

In addition, the equipment shall detect the following condition in accordance with subclause A.9.2.2.2:

- c) AIS at n x 64 kbit/s at reference point M2 when the CCITT Recommendation V.38 [24] scrambling/descrambling function is activated.

### A.7 CCITT Recommendation X.24 interface (subclause 10.4.2.6)

Table 12 of subclause 10.4.2.6 shall be replaced by the following table:

**Table A.1: Consequent actions for CCITT Recommendation X.24 [28] tributary**

Defect or failure condition	Failure information generated	Consequent action	
		P2	M1 (or J1)
Failure of circuit T	(note 1)		1/0 (note 2)
Failure of circuit C (when provided)			OFF (note 3)
Failure of circuit X			(note 5)
Loss of connection between DTE and DCE			1/0-OFF(note 2 and 4)
AIS at n x 64 kbit/s		1/0-OFF (note 6)	
Loss of power at the DTE			1/0-OFF (note 2 and 4)
NOTE 1: Defect or failure conditions are notified to the EMF via reference points S11, S12 or S13. Consequent actions related to the generation of failure information are specified in part 2 of this ETS (DE/TM-01013-3 [35]).			
NOTE 2: Continuous bit stream of ONES or ZEROS is applied depending upon the configuration of the tributary interface.			
NOTE 3: An OFF condition is applied on control signal when C circuit is provided.			
NOTE 4: An OFF condition is applied on control signal when it is transferred.			
NOTE 5: The transmit signal is timed with the S signal.			
NOTE 6: Continuous bit stream of ZEROS or ONES depending on the application is applied on the R circuit and an OFF condition is applied on the I circuit.			

**A.8 CCITT Recommendation V.24 (V.10 and V.11) interface (subclause 10.4.2.7)**

Table 13 of subclause 10.4.2.7 shall be replaced by the following table:

**Table A.2: Consequent actions for CCITT Recommendation V.24 [21] tributary**

Defect or failure condition	Failure information generated	Consequent action	
		P2	M1 (or J1)
Loss of the connection between the DTE and DCE	(note 1)		1-OFF
AIS at n x 64 kbit/s at reference point M2		109 = OFF (note 2)	(note 2 and 3)
Loss of power at the DTE			1-OFF (note 3)
NOTE 1: Defect or failure conditions are notified to the EMF via reference points S11, S12 or S13. Consequent actions related to the generation of failure information are specified in part 2 of this ETS (DE/TM-01013-3 [35]).			
NOTE 2: AIS signal at reference point M2 implies continuous ONEs on the 104 circuit.			
NOTE 3: All "1" applied on data signal and "OFF" condition on control signal(s) being transferred.			

## **Annex B (normative):      Analogue tributary interfaces, 32 kbit/s coding**

### **B.1    2-wire/4-wire voice band (3 400 Hz) interface**

This optional interface provides 2-wire or 4-wire connections for a voiceband channel in the frequency band 300 Hz to 3 400 Hz without d.c. signalling. The ADPCM method of coding at 32 kbit/s is specified. This interface type is applicable to analogue leased lines.

Recommendations about the use of 32 kbit/s ADPCM for speech and non-speech services can be found in Appendix 1 of CCITT Recommendation G.721 [8].

#### **B.1.1    Physical interface**

At reference point P a 2-wire or 4-wire interface shall be provided.

The nominal impedance of the interface shall be in accordance with CCITT Recommendation G.712 [7]. References to specific sections of CCITT Recommendations G.712 [7] relating to nominal impedance of 2-wire and 4-wire interfaces are contained in table 1.

#### **B.1.2    Coding**

The analogue signal shall be A-law encoded into 64 kbit/s in accordance with CCITT Recommendation G.711 [6] and then converted to 32 kbit/s ADPCM in accordance with CCITT Recommendation G.721 [8]. Complementary decoding shall also be provided.

#### **B.1.3    Performance**

The overall performance of the channel between the analogue interface and 64 kbit/s A-law encoding and decoding shall be in accordance with CCITT Recommendation G.712 [7]. References to specific sections of CCITT Recommendations G.712 [7] relating to characteristics of input and output ports of 2-wire and 4-wire interfaces are contained in table 1.

The performance of the conversion between 64 kbit/s A-law coding and 32 kbit/s ADPCM and the reverse operation shall be in accordance with CCITT Recommendation G.721 [8].

#### **B.1.4    Signalling**

This interface may carry in-band a.c. tone signalling. The equipment will not need to process this signalling.

#### **B.1.5    Signal at reference point M**

reference point M is specified in terms of 64 kbit/s channels. The signal at reference point M is therefore specified in terms of one or two 32 kbit/s signals into a 64 kbit/s channel.

At reference point M one or two 32 kbit/s encoded analogue signals shall use one 64 kbit/s channel in each direction.

#### **B.1.6    Cross connection rules**

If the tributary signal is cross connected to an aggregate interface then:

- a) the signal at reference point M shall use one TS chosen from TSs 1 to 15 or 17 to 31 at reference point G;
- b) if TS 16 at reference point G is not configured for channel associated signalling or control then the signal may use TS 16 at reference point G;

- c) the first 32 kbit/s signal shall use bits 1, 2, 3 and 4 of the TS at reference point G and the second 32 kbit/s signal, if provided, shall use bits 5, 6, 7 and 8.

### **B.1.7 Configurable parameters**

The following parameters shall be configurable by the EMF via reference point S11, S12 or S13 in accordance with part 2 of this ETS (DE/TM-01013-3 [35]):

- a) 2-wire or 4-wire operation (note);
- b) audio signal levels.

NOTE: Optionally the selection between 2-wire and 4-wire operation can be done by making a physical change at the tributary interface.

### **B.1.8 Test functions**

The following test functions shall be provided controlled by the EMF via reference points S11, S12 or S13 in accordance with part 2 of this ETS (DE/TM-01013-3 [35]):

- a) connection of the external 2-wire or 4-wire circuit at reference point P to a metallic test bus;
- b) analogue loopback from reference point O2 to reference point O1 or optionally from reference point N2 to reference point N1. With the loopback applied no audio signal shall be present at reference point P2.

Indication on tests that can be used with loopbacks are given in clause 12.

## **B.2 2-wire/4-wire voice band (3 400 Hz) with d.c. signalling interface**

This optional interface provides 2-wire or 4-wire connections for a voiceband channel in the frequency band 300 to 3 400 Hz with d.c. signalling. The ADPCM method of coding at 32 kbit/s is specified. This interface type is applicable to analogue leased lines.

Recommendations about the use of 32 kbit/s ADPCM for speech and non-speech services can be found in Appendix 1 of CCITT Recommendation G.721 [8].

### **B.2.1 Physical interface**

At reference point P a 2-wire or 4-wire interface shall be provided which supports d.c. signalling.

The nominal impedance of the interface shall be in accordance with CCITT Recommendations G.712 [7]. References to specific sections of CCITT Recommendations G.712 [7] relating to nominal impedance of 2-wire and 4-wire interfaces are contained in table 1.

### **B.2.2 Coding**

The analogue signal shall be A-law encoded into 64 kbit/s in accordance with CCITT Recommendation G.711 [6] and then converted to 32 kbit/s ADPCM in accordance with CCITT Recommendation G.721 [8]. Complementary decoding shall also be provided.

### **B.2.3 Performance**

The overall performance of the channel between the analogue interface and 64 kbit/s A-law encoding and decoding shall be in accordance with CCITT Recommendation G.712 [7]. References to specific sections of CCITT Recommendations G.712 [7] relating to characteristics of input and output ports of 2-wire and 4-wire interfaces are contained in table 1.

The performance of the conversion between 64 kbit/s A-law coding and 32 kbit/s ADPCM and the reverse operation shall be in accordance with CCITT Recommendation G.721 [8].

#### **B.2.4 Signalling**

The interface shall provide d.c. signalling. Examples of such signalling systems are:

- a) 2-wire or 4-wire E and M;
- b) an earth calling signalling method for 2-wire interfaces for PABXs;
- c) a loop calling, disconnect clear signalling method for 2-wire interfaces including direct dialling inward/outward for PABXs;
- d) double current d.c. signalling.

The d.c. signalling conditions shall be encoded into the a and b or c and d bits of channel associated signalling. The complementary decoding shall also be provided.

Particular specifications for the appropriate signalling method, and its encoding into the a and b or c and d bits, should be determined by individual administrations in accordance with CCITT Recommendation G.761 [13], §§ 2.5.

This interface may also carry in-band a.c. tone signalling. The equipment will not need to process this a.c. signalling.

#### **B.2.5 Signal at reference point M**

Reference point M is specified in terms of 64 kbit/s channels and 4 x 500 bit/s channels for encoded signalling. The signal at reference point M is therefore specified in terms of one or two 32 kbit/s signals into a 64 kbit/s channel and one or two group of 2 x 500 bit/s signals into 4 x 500 bit/s channels.

At reference point M one or two 32 kbit/s encoded analogue signals shall use one 64 kbit/s channel in each direction. In addition one or two encoded signalling channels shall use 2 x 500 bit/s channels each in each direction.

#### **B.2.6 Cross connection rules**

If the tributary signal is cross connected to an aggregate interface then:

- a) the signal at reference point M shall use one TS chosen from TSs 1 to 15 or 17 to 31 at reference point G;
- b) the first 32 kbit/s signal shall use bits 1, 2, 3 and 4 of the TS at reference point G and the second 32 kbit/s signal, if provided, shall use bits 5, 6, 7 and 8;
- c) the channel associated signalling at reference point M shall use the corresponding a, b, c and d bits in TS 16 at reference point G;
- d) the channel associated signalling b and d bits, if used, shall be processed in accordance CCITT Recommendation G.761 [13], §§ 2.5.1.1.3.

#### **B.2.7 Configurable parameters**

The following parameters shall be configurable by the EMF via reference point S11, S12 or S13 in accordance with part 2 of this ETS (DE/TM-01013-3 [35]):

- a) 2-wire or 4-wire operation (note 1);
- b) audio signal levels;

- c) use of signalling bits;
- d) signalling type (note 2);
- e) default value for d.c. signalling under failure condition;
- f) TS allocation at G reference point;
- g) activation of CAS cross connection function.

NOTE 1: Optionally the selection between 2-wire and 4-wire operation can be done by making a physical change at the tributary interface.

NOTE 2: Optionally the selection of signalling type can be done by making a physical change at the tributary interface. Variation of parameters within a basic signalling type could still be provided by the EMF via reference point S11, S12 or S13.

### **B.2.8 Test functions**

The following test functions shall be provided controlled by the EMF via reference points S11, S12 or S13 in accordance with part 2 of this ETS (DE/TM-01013-3 [35]):

- a) connection of the external 2-wire or 4-wire circuit, and any additional signalling wires, at reference point P to a metallic test bus;
- b) analogue loopback from reference point O2 to reference point O1 or optionally from reference point N2 to reference point N1. With the loopback applied no audio signal shall be present and the signalling condition shall be set to idle at reference point P2.

Indication on tests that can be used with loopbacks are given in annex F.

## **B.3 Defects or failure conditions at reference points P1 or P2**

### **B.3.1 2-wire/4-wire voice band (3 400 Hz) interface**

No failure conditions are specified for this interface.

### **B.3.2 2-wire/4-wire voice band (3 400 Hz) with d.c. signalling interface**

No failure conditions are specified for this interface.

Particular specifications for signalling defect or failure conditions should be determined by individual administrations.

## **B.4 Consequent actions at reference points P2 and M1 (or J1)**

After the detection of a defect or failure condition, according to subclauses B.3.1 and B.3.2, appropriate consequent actions shall be taken as specified in subclauses B.4.1 and B.4.2.

### **B.4.1 2-wire/4-wire voice band (3 400 Hz) interface**

No consequent actions are specified for this interface.

**B.4.2 2-wire/4-wire voice band (3 400 Hz) with d.c. signalling interface**

No consequent actions are specified for this interface.

Particular specifications for consequent actions due to signalling defect or failure conditions at P1 or P2 reference point should be determined by individual administrations. Nevertheless, requirement for the application of a default value for d.c. signalling under failure condition detected on the aggregate side or in core functions remains (see subclause 9.1.2.7).



## Annex C (informative): The position and use of loopbacks for testing data channels

### C.1 The use of loopbacks

Loopback test are used in order to verify proper tributary interface and end to end transmission performance and isolate faults to a specific equipment area. The required loopback is set and then the local end transmits known data patterns and verifies reception of the same patterns after it has passed round the loop. By sequentially applying different loopbacks a failure can be localized to a DTE, tributary interface, a FM or the transmission network in between the FMs.

### C.2 Local loopbacks

A local loopback test is used to verifies the integrity of the local-end of the circuit.

#### C.2.1 Local loopbacks CCITT Recommendation X.150

##### C.2.1.1 Loopback 1

Local loopback 1, in accordance with CCITT Recommendation X.150 [26], is shown in figure C.1. Loopback 1 loops the signal within the DTE. The loopback is used when testing the DTE. Loopback 1 can not be used to test the FM tributary interface.

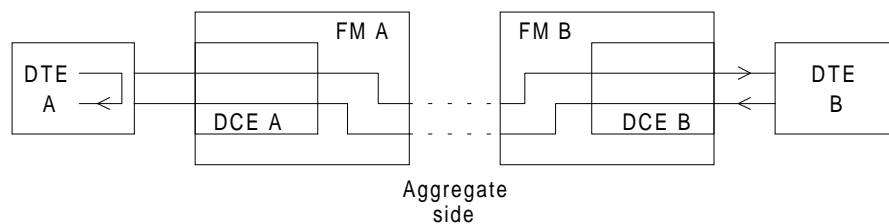

Figure C.1: CCITT Recommendation X.150 [26], loopback 1

##### C.2.1.2 Loopback 3c

Local loopback 3c, in accordance with CCITT Recommendation X.150 [26], is shown in figure C.2. Loopback 3c loops the signal within the FM tributary interface from reference point O1 to reference point O2 or optionally from reference point N1 to reference point N2. The loopback is used when testing the interconnection between the DTE and the FM and the satisfactory working of the FM DCE tributary interface interchange circuits generators and loads.

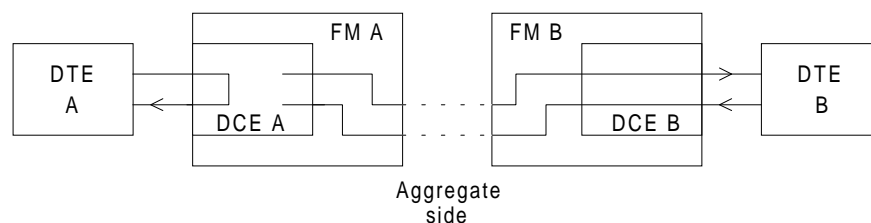
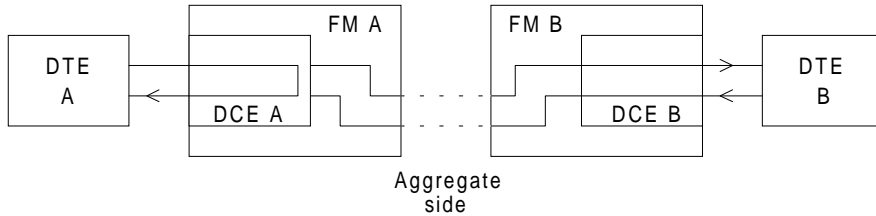

Figure C.2: CCITT Recommendation X.150 [26], loopback 3c

**C.2.1.3 Loopback 3b**

Local loopback 3b, in accordance with CCITT Recommendation X.150 [26], is shown in figure C.3. Loopback 3b loops the signal within the FM tributary interface from reference point N1 to reference point N2 or optionally from reference point M1 to reference point M2. The loopback is used when testing the interconnection between the DTE and the FM and the satisfactory working of the local FM DCE function.

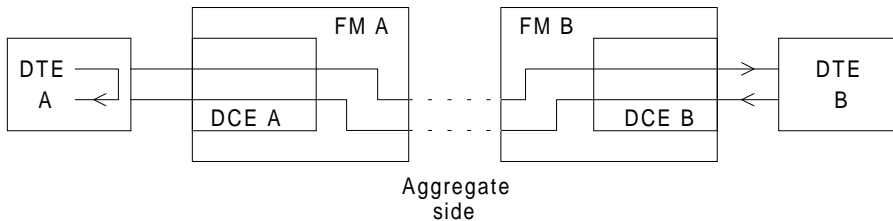

**Figure C.3: CCITT Recommendation X.150 [26], loopback 3b**

**C.2.2 Local loopbacks CCITT Recommendation V.54**

**C.2.2.1 Loopback 1**

Local loopback 1, in accordance with CCITT Recommendation V.54 [25], is shown in figure C.4. Loopback 1 loops the signal within the DTE. The loopback is used when testing the DTE. Loopback 1 can not be used to test the FM tributary interface.



**Figure C.4: CCITT Recommendation V.54 [25], loopback 1**

**C.2.2.2 Loopback 3**

Local loopback 3, in accordance with CCITT Recommendation V.54 [25], is shown in figure C.5. Loopback 3 loops the signal within the FM tributary interface from reference point N1 to reference point N2 or optionally from reference point M1 to reference point M2. The loopback is used when testing the interconnection between the DTE and the FM and the satisfactory working of the local FM DCE function.

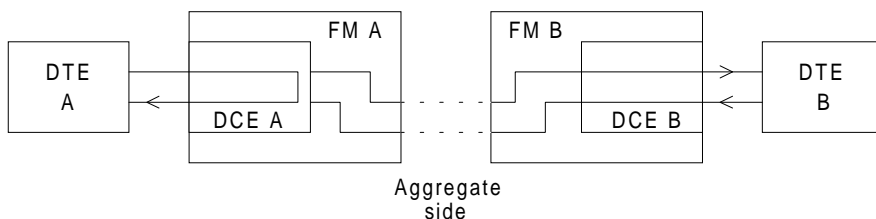

**Figure C.5: CCITT Recommendation V.54 [25], loopback 3**

### C.3 Remote loopbacks

A remote loopback test is used to verify the integrity of the end-to-end circuit.

#### C.3.1 Remote loopbacks CCITT Recommendation X.150

##### C.3.1.1 Loopback 4b

Remote loopback 4b, in accordance with CCITT Recommendation X.150 [26], is shown in figure C.6. Loopback 4b loops the signal within the remote FM Cross Connect function from reference point J2 to reference point J1. The loopback is used when testing the interconnection between the local and remote FMs.

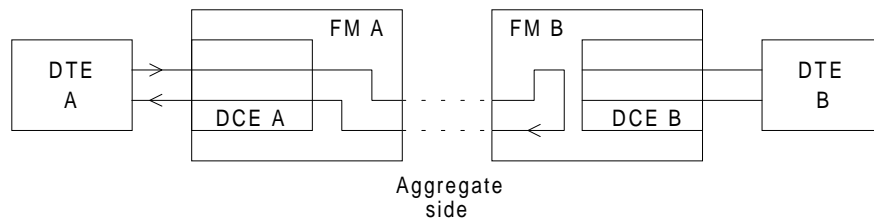

Figure C.6: CCITT Recommendation X.150 [26], loopback 4b

##### C.3.1.2 Loopback 2b

Remote loopback 2b, in accordance with CCITT Recommendation X.150 [26], is shown in figure C.7. Loopback 2b loops the signal within the remote FM tributary interface from reference point O2 to reference point O1 or optionally from reference point N2 to reference point N1. The loop is used when testing the interconnection between the local and remote FMs and the satisfactory working of the remote DCE function.

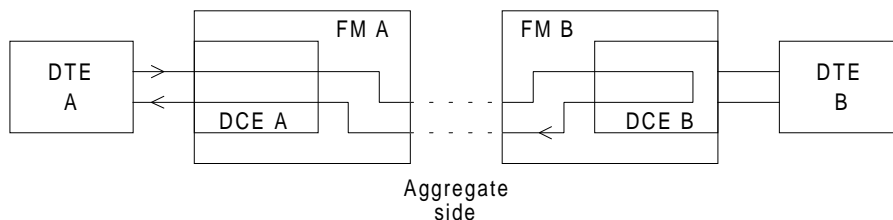

Figure C.7: CCITT Recommendation X.150 [26], loopback 2b

#### C.3.2 Remote loopbacks CCITT Recommendation V.54

##### C.3.2.1 Loopback 4

Remote loopback 4, in accordance with CCITT Recommendation V.54 [25], is shown in figure C.8. Loopback 4 loops the signal within the remote FM Cross Connect function from reference point J2 to reference point J1. The loopback is used when testing the interconnection between the local and remote FMs.

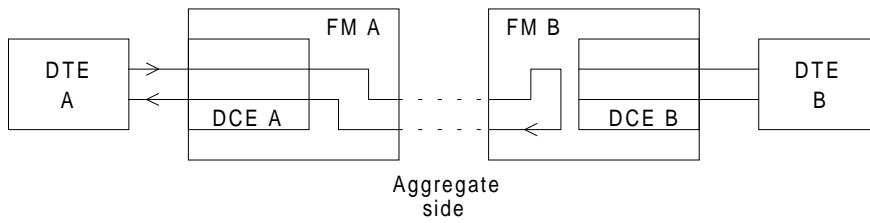

Figure C.8: CCITT Recommendation V.54 [25], loopback 4

### C.3.2.2 Loopback 2

Remote loopback 2, in accordance with CCITT Recommendation V.54 [25], is shown in figure C.9. Loopback 2 loops the signal within the remote FM tributary interface from reference point O2 to reference point O1 or optionally from reference point N2 to reference point N1. The loop is used when testing the interconnection between the local and remote FMs and the satisfactory working of the remote DCE function.

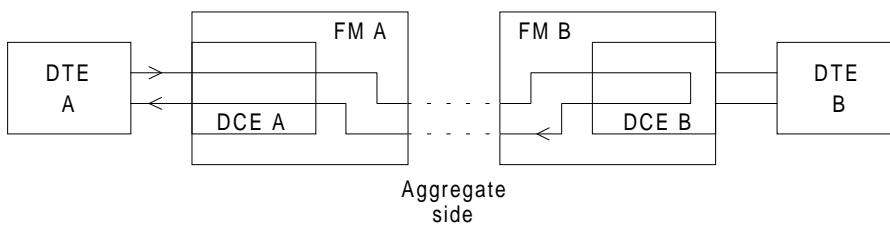

Figure C.9: CCITT Recommendation V.54 [25], loopback 2

## Annex D (informative): Special functions

This annex provides information on optional special functions but does not provide sufficient information to allow full standardization. The special functions are provided at reference point K. Configuration control and test of the special functions is provided by the EMF via reference point S8.

### D.1 Analogue multipoint conference bridge

#### D.1.1 General

In this ETS an analogue conference bridge is a function for use with leased line circuits. It can be used for analogue signals encoded according to one of the following standards:

- A-law PCM in accordance with CCITT Recommendation G.711 [6];
- ADPCM in accordance with CCITT recommendation G.721 [8];
- SB-ADPCM in accordance with CCITT Recommendation G.722 [9].

The conference bridge carries out the following functions:

- interchanges signals with the virtual core of the FM;
- receives 32 kbit/s or 64 kbit/s voice signals to be summed;
- transmits summed 32 kbit/s or 64 kbit/s voice signals;
- receives corresponding channel associated signalling to be summed (optional);
- transmits combined channel associated signalling (optional);
- is configured via a management interface of the FM.

The reference model and functional parts of a conference bridge are shown in figure D.1 and are as follows:

- conversion from A-law PCM, ADPCM or SB-ADPCM to uniform PCM;
- summing of uniform PCM signals;
- conversion from uniform PCM to A-law PCM, ADPCM or SB-ADPCM;
- processing of ADPCM signalling (optional);
- summing of channel associated signalling (optional).

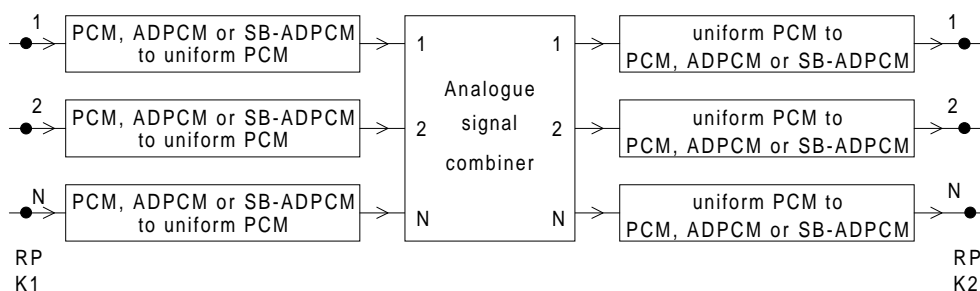

a) Summing of analogue signals

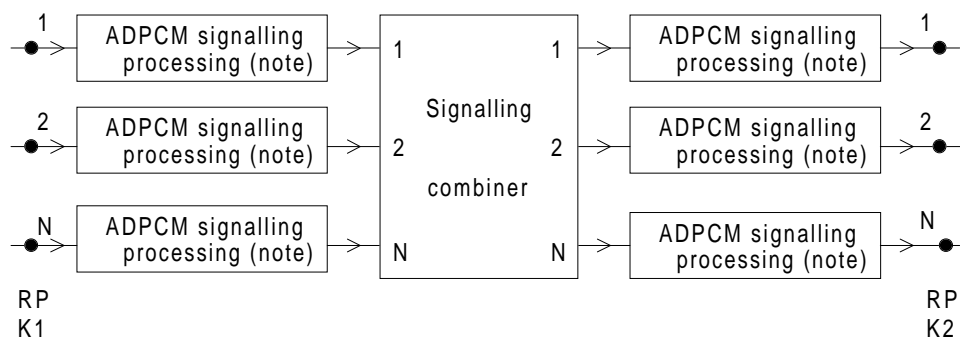

NOTE: For use with 32 kbit/s ADPCM only.

b) Summing of signalling

Figure D.1: Analogue conference bridge

D.1.2 Code conversion

D.1.2.1 64 kbit/s PCM

The conversion from 64 kbit/s A-law PCM to uniform PCM and the inverse operation should be in accordance with CCITT Recommendation G.711 [6].

D.1.2.2 32 kbit/s ADPCM

The conversion from 32 kbit/s ADPCM to uniform PCM and the inverse operation should be in accordance with CCITT Recommendation G.721 [8].

D.1.2.3 64 kbit/s SB-ADPCM

The conversion from 64 kbit/s SB-ADPCM to uniform PCM and the inverse operation should be in accordance with CCITT recommendation G.722 [9].

D.1.3 Summing of uniform PCM signals

D.1.3.1 Summing

The N-port bridge receives N uniform PCM signals and transmits N summed signals. Each summed signal is the arithmetic sum of N - 1 input signals. The input related to the summed output is omitted.

N

$$\text{Out}_i = \sum_{k=1, k \neq i}^N \text{In}_k \quad \text{where } \text{In}_k = \text{the } k^{\text{th}} \text{ input signal and } k=1, \text{ then}$$

$$\text{Out}_i = \text{the } i^{\text{th}} \text{ output signal} \quad k \neq i$$

The accuracy of the summation is 13 bits.

D.1.3.2 Overload

If the sum exceeds the most positive uniform PCM code, the output is constrained to the most positive PCM code. If the sum exceeds the most negative uniform PCM code, the output is constrained to the most negative PCM code.

### D.1.3.3 Offset control

Accumulation of idle signal encoder offset causes excessive quantizing distortion. Suitable methods of offset cancellation are:

- a) inverting of every other input signal;
- b) adding an offset cancelling code to the summing input. The offset is cancelled when the probability of positive and negative codes is equal at the sum output.

At idle input condition, the output offset at the branches of the conference circuit should not exceed +/- 10 steps (a step means a character signal according to the ITU-T definition).

### D.1.3.4 AIS signal elimination

Alarm Indication Signals (AIS) at the input of the bridge would cause a significant code offset. When an AIS signal is detected at the input of the conference bridge, the corresponding uniform PCM input signal should be set to code + 0 or - 0. The AIS signal should be assumed to be detected when two or more consecutive input samples to the bridge equals all ones. When two consecutive samples not equal to all ones are received, the input signal should be restored.

### D.1.3.5 Delay

The delay caused by the conference function should not exceed  $x \mu\text{s}$ . Suitable values for  $x$  could be 125 or 250.

### D.1.3.6 Configuration

As a minimum, the following parameters should be configurable:

- a) activation/deactivation of input signals;
- b) activation/deactivation of corresponding signalling inputs (optional).

### D.1.4 Signalling

If required the channel associated signalling channels a, b, c, and d corresponding to the N input signals should be combined (a, b, c and d channel are combined separately) using a logic AND function. Prior to combining, the b and d bits related to 32 kbit/s ADPCM channels should be processed (receiver side) in accordance with CCITT Recommendation G.761 [13], §§ 2.5.1. After combining, the b and d bits related to 32 kbit/s ADPCM channels are processed (sender side) in accordance with CCITT Recommendation G.761 [13], §§ 2.5.1.

N

$S_{o_j} = S_{i_k}$ , where  $S_{i_k}$  = input signal number k and

k=1  $S_{o_j}$  = output signal number j.

k≠j

The signalling bit of the channel corresponding to the output is omitted.

### D.1.5 Network aspects

The conference bridge itself should not cause any attenuation or changes in the frequency characteristics of the signals. The following points need to be taken into account:

- a) in applications where several branches simultaneously may be active, the relative levels at the channel inputs may need to be adjusted to avoid overload and amplitude clipping at the conference bridge;
- b) to compensate for noise and echo which increases as the number of ports are increased, the circuit loss may need to be adjusted in accordance with CCITT Recommendation G.172 [1].

## D.2 Data multipoint bridge

### D.2.1 General

In this ETS a point-to-multipoint data bridge is a function that carries out the following:

- a) interchanges signals with the core of the FM;
- b) deframes framed signals;
- c) broadcasts data, and optionally control signals, in the direction from the master to the slaves;
- d) combines data, and optionally control signals, in the direction from the slaves to the master;
- e) where applicable frames signals;
- f) is configured by the management interface of the FM.

Two alternative methods for control of data combining are recommended:

- a) for data channels without end to end control signalling refer to subclause D.2.2;
- b) for data channels with end to end control signalling refer to subclause D.2.3.

### D.2.2 Multipoint data bridge not using end to end control signals

For this type of data multipoint bridge the data interface control signals are not transmitted across the network. The reference model and functional parts of the point-to-multipoint data bridge without end to end control signals are shown in figure D.2.

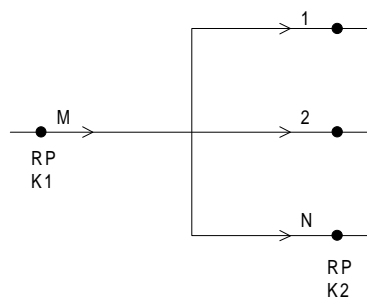

a) Master to slaves



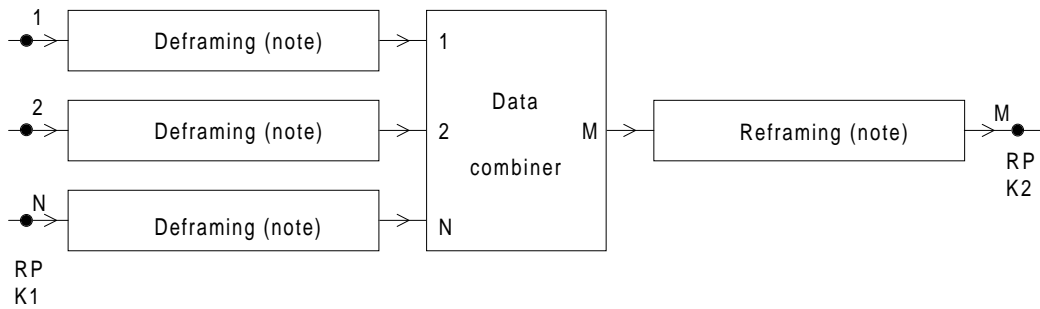

NOTE: Framed signals only.

b) Slaves to master

**Figure D.2: Multipoint data bridge**

#### **D.2.2.1 Master to slaves**

The data signals are broadcast to all slaves in the direction from the master to the slaves.

#### **D.2.2.2 Slaves to master**

The data signals are combined in the direction from the slaves to the master. The framed signals are deframed before combining. After combining, the signal is reframed. The data signals are combined using a logical AND function. The method implies that for correct operation:

- a) when in the idle state the input signals should be constrained to the value 1;
- b) the idle state value is set by the local control signal at the access interfaces of the data circuit;
- c) AIS signals will not disturb the data transmission.

#### **D.2.2.3 Delay**

The delay caused by the combining bridge should not exceed  $x \mu\text{s}$  excluding the delay of the deframing and reframing. Suitable values for  $x$  could be 125 or 250.

#### **D.2.2.4 Configuration**

Cs a minimum, the following parameter should be configurable:

- activation/deactivation of input signals.

**D.2.3 Multipoint data bridge using end-to-end control signals**

For this type of multipoint data bridge the data interface control signals are transmitted across the network along with the data signals. The reference model and functional parts of a point-to-multipoint data bridge with end-to-end control signals is shown in figure D.3.

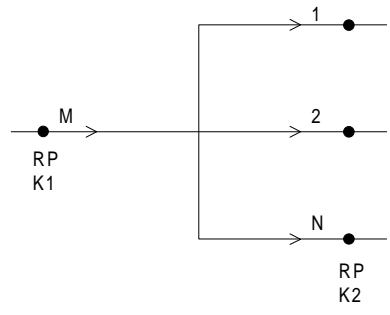

a) Master to slaves

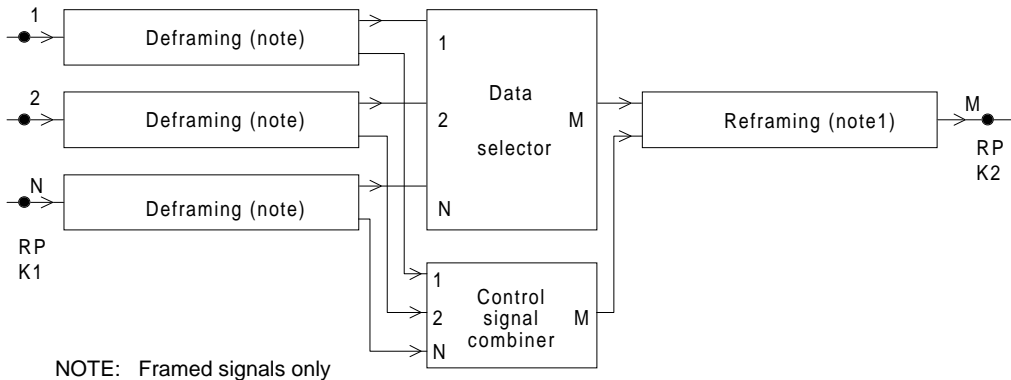

b) Slaves to master  
**Figure D.3: Multipoint data bridge**

**D.2.3.1 Master to slaves**

The data and control signals are broadcasted to all slaves in the direction from the master to the slaves.

**D.2.3.2 Slaves to master**

The data and control signals are combined in the direction from the slaves to the master under the control of the data interface control signals transmitted across the network.

The method of transfer of the control signal may be:

- a) for data interface circuits C/I in accordance with subclause 9.2.2.4;
- b) for data interface circuits 105/109 in accordance with subclause 9.2.3.4.

The framed data signals are deframed before combination. After combining, the signal is reframed.

One at a time, one of the output signals is connected to the output of the combiner. The signal selection is controlled by the control signals of the inputs. When no input signal is active, the combiner data and control signal outputs are set to the idle condition.

The control signals are combined using an AND function which implies that for correct operation only one slave should have its control signal on at any one time.

### D.2.3.3 Delay

The delay caused by the combining bridge should not exceed  $x \mu\text{s}$  excluding the delay of deframing and reframing. Suitable values for  $x$  could be 125 or 250.

### D.2.3.4 Configuration

As a minimum, the following parameters should be configurable:

- activation/deactivation of input signals.

## D.3 Broadcasting

The broadcasting function is unidirectional. The reference model of the broadcast function is shown in figure D.4.

The data signal, including the corresponding signalling or control signals, are broadcast to all slave destinations of the circuit. The return direction is considered unused and may be used for other purposes.

The broadcast function should not introduce any additional delay or signal impairment.

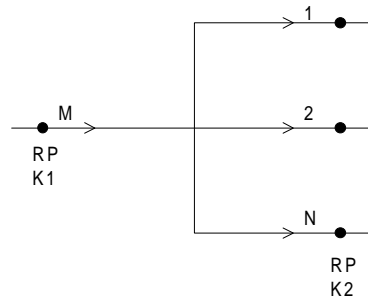

Master to slaves

**Figure D.4: Broadcast function**

## **Annex E (informative): Possible methods for transferring control signals at reference point M**

The transfer of control information from the tributary signal may use one of the following methods.

### **E.1 Channel associated signalling in TS 16**

In case where CAS is used on the corresponding aggregate, up to four 500 bit/s channels on a, b, c and d signalling bits associated to the  $n \times$  TSs of the corresponding  $n \times$  64 kbit/s channel may be selected for control signal(s) transfer. It is assumed that the value of a, b, c and d bits is repeated in the  $n$  corresponding quartets of the CAS multiframe. If only one control signal is to be transferred, the a bit should be preferably selected.

### **E.2 In-band procedure**

When CAS is not available or not used in the corresponding aggregate, the in-band procedure defined in CCITT Recommendation V.13 [20] may be applied for the transfer of one control signal. This applies to the 105 and 109 circuits in case of CCITT Recommendation V.24 [21] tributary interface.

In case of CCITT Recommendation X.24 [28] tributary interface, this procedure is applied to the C and I circuits in place of 105 and 109 circuits respectively.

### **E.3 Other methods**

Alternatively, another free TS may be used on the aggregate for the control signal(s) transfer function.

It is not precluded to implement mechanisms derived from the V5 interface specifications.

## **Annex F (informative): Test functions**

This annex provides information on testing functions which may be implemented in the FM. Testing usually includes a general check of all major components in a communication path, i.e. local and remote FMs, the interfaces and the intervening link.

The following network diagnostic features should be made available at each FM:

- a) the ability to run diagnostic tests without interfering with the operation of the rest of the FM and the rest of the network;
- b) the ability to take any one individual tributary or aggregate interface out of service rather than an entire FM.

Internal self-tests as well as local and remote diagnostics should be made available to verify the functional operation of the FM.

The diagnostic tests should permit fault localization in one of the three following ways:

- a) via the front panel switch;
- b) via hardware interface with signals;
- c) through software via a local or remote man-machine interface.

### **F.1 Internal self tests**

It should be possible to initiate tests for the core functions and an automatic diagnostic procedure to check the tributary or aggregate interfaces before bringing into service. For tributary interfaces the software tests the interface card whereas in the case of aggregate interfaces, the software tests both the interface card and the media concerned.

Complementary information is given in part 2 of this ETS (DE/TM-01013-3 [35]).

### **F.2 Tributary tests and transmission testing**

These tests are required in order to verify proper interface performance and isolate faults to a specific component or interface. Furthermore, in some applications it may be required to incorporate transmission testing functions within the equipment.

To test looped circuits, the following test patterns could be used:

- a) pseudo random,  $2^{20} - 1$ ;
- b) all ones;
- c) mostly ones (one byte zero, 255 bytes ones);
- d) others.

**Annex G (informative): Bibliography**

- 1) ISO 4902 (1981): "Data communication - 37 pin and 9 pin DTE/DCE interface connector and pin assignments".
- 2) ISO 11569 (1993): "Information technology - Telecommunications and information exchange between systems - 26-pole interface connector mateability dimensions and contact number assignments".

## History

<b>Document history</b>	
January 1995	Public Enquiry PE 76: 1995-01-02 to 1995-04-28
April 1996	Converted into Adobe Acrobat Portable Document Format (PDF)