



**E**UROPEAN  
**T**ELECOMMUNICATION  
**S**TANDARD

**ETS 300 453**

February 1996

---

Source: ETSI TC-BTC

Reference: DE/BTC-02032

ICS: 33.020

**Key words:** ONP, leased line, A4O, A4S

**Business TeleCommunications (BTC);  
Ordinary and Special quality voice bandwidth  
4-wire analogue leased lines (A4O and A4S);  
Terminal equipment interface**

**ETSI**

European Telecommunications Standards Institute

**ETSI Secretariat**

**Postal address:** F-06921 Sophia Antipolis CEDEX - FRANCE

**Office address:** 650 Route des Lucioles - Sophia Antipolis - Valbonne - FRANCE

**X.400:** c=fr, a=atlas, p=etsi, s=secretariat - **Internet:** secretariat@etsi.fr

Tel.: +33 92 94 42 00 - Fax: +33 93 65 47 16

\*

---

**Copyright Notification:** No part may be reproduced except as authorized by written permission. The copyright and the foregoing restriction extend to reproduction in all media.

© European Telecommunications Standards Institute 1996. All rights reserved.



## Contents

Foreword .....	5
Introduction .....	5
1 Scope .....	7
2 Normative references .....	7
3 Definitions and abbreviations .....	7
3.1 Definitions .....	7
3.2 Abbreviations .....	8
4 Requirements .....	8
4.1 Physical characteristics .....	8
4.2 Electrical characteristics .....	9
4.2.1 Return loss .....	9
4.2.2 Longitudinal conversion loss .....	9
4.2.3 Transmission signals .....	10
4.2.3.1 Equipment with an acoustic input .....	10
4.2.3.1.1 Sending Loudness Rating (SLR) .....	10
4.2.3.2 Equipment with internally generated electrical signals .....	11
4.2.3.2.1 Maximum mean power .....	11
4.2.3.2.2 Maximum instantaneous power (peak voltage) .....	11
4.2.3.2.3 Maximum power in a 10 Hz bandwidth .....	11
4.2.3.3 Equipment with an electrical input .....	12
4.2.4 Maximum sending power above 4,3 kHz .....	12
4.2.5 Power feeding .....	13
4.3 Safety .....	13
4.4 ElectroMagnetic Compatibility (EMC) .....	13
Annex A (normative): Test methods .....	15
A.1 General .....	15
A.1.1 Equipment connection .....	15
A.1.2 Reference impedance .....	15
A.1.3 Non-reactive termination .....	15
A.2 Test methods .....	15
A.2.1 Return loss .....	15
A.2.2 Longitudinal conversion loss .....	16
A.2.3 Sending Loudness Rating (SLR) .....	17
A.2.4 Maximum mean power .....	19
A.2.5 Maximum instantaneous power (peak voltage) .....	20
A.2.6 Maximum power in a 10 Hz bandwidth .....	21
A.2.7 Maximum sending power above 4,3 kHz .....	21
A.2.8 Power feeding .....	23
Annex B (informative): Bibliography .....	24
History .....	25

Blank page

## Foreword

This European Telecommunication Standard (ETS) has been produced by the Business Telecommunications (BTC) Technical Committee of the European Telecommunications Standards Institute (ETSI).

This ETS resulted from a mandate from the Commission of the European Community (CEC) to provide harmonised standards for the support of the Directive on Open Network Provision (ONP) of leased lines (92/44/EEC).

There are two other standards directly related to this ETS:

ETS 300 451: "Business Telecommunications (BTC); Ordinary quality voice bandwidth 4-wire analogue leased line (A4O); Connection characteristics and network interface presentation".

ETS 300 452: "Business Telecommunications (BTC); Special quality voice bandwidth 4-wire analogue leased line (A4S); Connection characteristics and network interface presentation".

This ETS is based on information from ITU-T Recommendations and ETSI publications and the relevant documents are quoted where appropriate.

Transposition dates	
Date of adoption of this ETS:	2 February 1996
Date of latest announcement of this ETS (doa):	31 May 1996
Date of latest publication of new National Standard or endorsement of this ETS (dop/e):	30 November 1996
Date of withdrawal of any conflicting National Standard (dow):	30 November 1996

## Introduction

The Council Directive on the application of ONP to leased lines (92/44/EEC), concerns the harmonization of conditions for open and efficient access to, and use of, the leased lines provided over public telecommunications networks and the availability throughout the European Union (EU) of a minimum set of leased lines with harmonised technical characteristics.

The consequence of the Directive is that telecommunications organisations within the EU shall make available a set of leased lines within and between points in these countries with specified connection characteristics and specified interfaces.

Two classes of standard will be used for the interfaces of terminal equipment designed for connection to the ONP leased lines. ETSs, which are voluntary, give the full technical specifications for these interfaces, whereas Technical Basis for Regulations (TBRs) give the essential requirements under the Second Phase Directive (91/263/EEC) for attachment to the leased lines. This standard, which is an ETS, belongs to the first category. The TBR (TBR 17) is a subset of this corresponding ETS.

CCITT Recommendations M.1020 (1988) and M.1040 (1988) are used as the basis for the leased line standards to which this terminal equipment interface relates.

Blank page

## 1 Scope

This European Telecommunication Standard (ETS) specifies the full physical and electrical characteristics and corresponding test principles for a terminal equipment interface for connection to the network termination points of Open Network Provision (ONP) ordinary quality or special quality voice bandwidth 4-wire analogue leased lines defined by ETS 300 451 and ETS 300 452. This ETS is not written for regulatory purposes.

This ETS is written only to ensure that the interface of the terminal equipment is compatible with the ONP ordinary quality or special quality voice bandwidth 4-wire analogue leased line. It is applicable to all interfaces designed for connection to these leased lines, however in the cases of apparatus that carries a particular service, of complex apparatus and of apparatus in private networks, other ETSs may apply in addition to this ETS.

Customer premises wiring and installation between the terminal equipment and the Network Termination Point (NTP) are outside the scope of this ETS.

## 2 Normative references

This ETS incorporates by dated and undated reference, provisions from other publications. These normative references are cited at the appropriate places in the text and the publications are listed hereafter. For dated references, subsequent amendments to or revisions of any of these publications apply to this ETS only when incorporated in it by amendment or revision. For undated references the latest edition of the publication referred to applies.

- [1] EN 28877 (1989): "Information processing systems - Interface connector and contact assignments for ISDN basic access interface located at reference points S and T".
- [2] EN 60950 (1992): "Safety of information technology equipment including electrical business equipment".
- [3] ITU-T Recommendation P.56 (1993): "Objective measurement of active speech level".
- [4] ITU-T Recommendation P.64 (1993): "Determination of sensitivity/frequency characteristics of local telephone systems".

NOTE: This ETS also contains a number of informative references which have been included to indicate the sources from which material has been derived, hence they do not have an associated normative reference number. Details of these publications are given in the annex B. In some cases the same publication may have been referenced in both a normative and an informative manner.

## 3 Definitions and abbreviations

### 3.1 Definitions

For the purposes of this ETS, the following definitions apply:

**leased lines:** The telecommunications facilities provided by a public telecommunication network that provide defined transmission characteristics between network termination points and that do not include switching functions that the user can control, (e.g. on-demand switching).

**Network Termination Point (NTP):** All physical connections and their technical access specifications which form part of the public telecommunication network and are necessary for access to and efficient communication through that public network.

**reference impedance  $Z_R$ :** This is 600  $\Omega$ . See also subclause A.1.2.

**terminal equipment:** Equipment intended to be connected to the public telecommunication network, i.e.:

- to be connected directly to the termination of a public telecommunication network; or
- to interwork with a public telecommunication network being connected directly or indirectly to the termination of a public telecommunication network,

in order to send, process, or receive information.

**voice bandwidth:** The band of frequencies over the range 300 Hz to 3 400 Hz.

### 3.2 Abbreviations

For the purposes of this ETS, the following abbreviations apply:

$a$	Return loss
DTMF	Dual Tone Multi-Frequency
EMC	ElectroMagnetic Compatibility
NTP	Network Termination Point
ONP	Open Network Provision
$P_m$	Sound pressure at the mouth reference point (used in the calculation of SLR)
rms	root mean square
RX	RX is a signal input (at either the terminal equipment or the test equipment, see figure 1)
SLR	Sending Loudness Rating
$S_{mJ}$	Sending sensitivity (used in the calculation of SLR)
$S_{mJn}$	Sending sensitivity at frequency $f_n$ (used in the calculation of SLR)
TNV	Telecommunications Network Voltage (see clause 6 of EN 60950 [2])
TX	TX is a signal output (at either the terminal equipment or the test equipment, see figure 1)
$W_{sn}$	Sending weighting factor (used in the calculation of SLR)
$Z_R$	Reference impedance
$Z_T$	Terminating impedance

## 4 Requirements

### 4.1 Physical characteristics

**Requirement:** The terminal equipment shall provide one or more of the following connection methods:

- a) an 8-contact plug of the type specified in EN 28877 [1] with contact assignments as specified in table 1;
- b) a set of connection contacts (e.g. an insulation displacement connector or screw terminal block) to which solid conductors with diameters in the range 0,4 to 0,6 mm may be connected;
- c) a wiring arrangement connected by any means to the terminal equipment, with unterminated solid wire conductors with diameters in the range 0,4 to 0,6 mm at the distant end from the terminal equipment.

Where a) and c) are provided, these may be detachable by the user such that only one is connected to the terminal equipment at any time.

NOTE: The normal presentation of the leased line is by means of a socket.



Table 1: Contact assignment

Contact number	terminal equipment
1	Unused
2	Unused
3 & 6	Transmit pair (Output port)
4 & 5	Receive pair (Input port)
7	Unused
8	Unused

NOTE: The transmit pair is the output from the terminal equipment. The receive pair is the input to the terminal equipment as shown in figure 1. Where the terms "output" and "input" are used without qualification in this ETS, they refer to the terminal equipment interface.

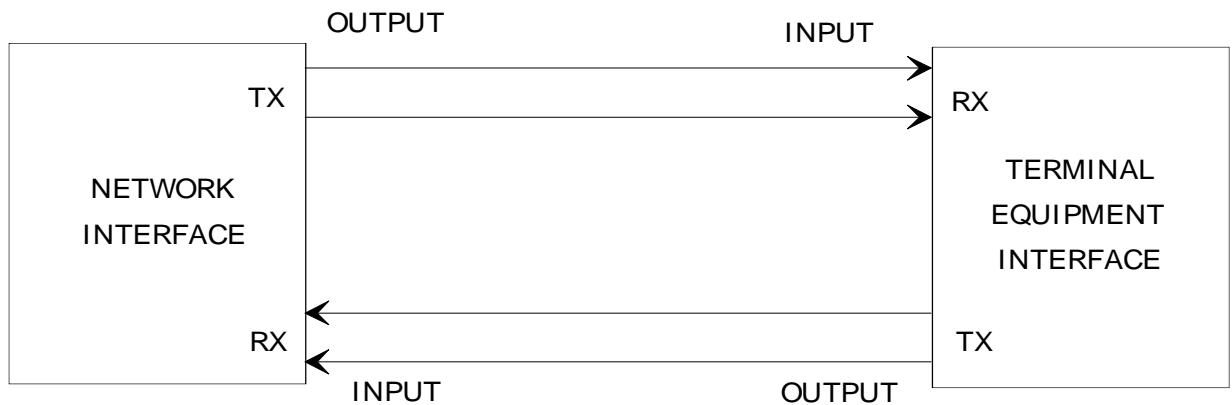

Figure 1: Leased line configuration conventions

**Test:** There shall be a visual inspection that one or more of the connection methods are provided. The contact assignments and connection methods are tested indirectly through the tests in annex A.

#### 4.2 Electrical characteristics

The requirements of subclause 4.2 apply only in the intended operating state of the terminal equipment.

##### 4.2.1 Return loss

**Requirement:** The return loss of the impedance of the input and output ports of the terminal equipment interface with respect to the reference impedance, in the frequency range 200 Hz to 4 000 Hz, shall be greater than or equal to 8 dB throughout the range when tested using a stimulus signal at a voltage equivalent to that of a signal power of -13 dBm at 1 020 Hz.

**Test:** The test shall be conducted according to subclause A.2.1.

##### 4.2.2 Longitudinal conversion loss

**Requirement:** The longitudinal conversion loss of the input and output ports of the terminal equipment interface shall be greater than or equal to the values given in table 2 and figure 2.

NOTE: The longitudinal conversion loss specifies the unwanted transverse signal detected by the terminal equipment when a longitudinal signal is applied equally to the terminals of the interface. Certain networks may have high longitudinal signal levels (e.g. 65 V root mean square (rms)); in this case, a higher longitudinal conversion loss may be necessary to ensure adequate operation of the terminal equipment.

**Table 2: Longitudinal conversion loss, minimum values**

Frequency range	Minimum value
300 Hz to 600 Hz	40 dB
600 Hz to 3 400 Hz	46 dB

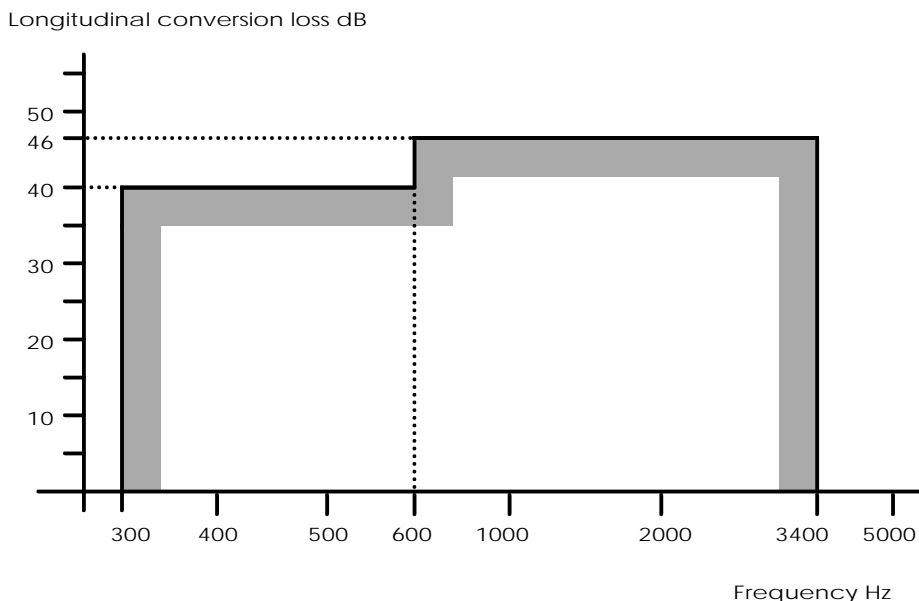

**Figure 2: Longitudinal conversion loss, minimum values**

**Test:** The test shall be conducted according to subclause A.2.2.

**4.2.3 Transmission signals**

The source and nature of the output signal from the terminal equipment interface can be classified in several different ways thus dividing the terminal equipments into several non-exclusive categories. One type of terminal equipment may therefore need to be treated as a member of more than one of the categories. For the purposes of this ETS the general categories requiring identification are defined as follows:

- a) any terminal equipment where the output signal is derived in real time from an integral acoustic interface. See subclause 4.2.3.1;
- b) any terminal equipment where the output signal is generated electrically within the terminal equipment. See subclause 4.2.3.2;
- c) any through connecting terminal equipment where the output signal is derived from another electrical interface. See subclause 4.2.3.3.

**NOTE:** Terminal equipments may belong to more than one category. A telephone may be in both category a) for telephony and category b) for the generation of Dual Tone Multi-Frequency (DTMF) tones. A function for generating synthetic or recorded speech or music, such as is found in answering machines or voice mail, is included in category b).

**4.2.3.1 Equipment with an acoustic input**

**4.2.3.1.1 Sending Loudness Rating (SLR)**

**Requirement:** The minimum SLR of the terminal equipment, when terminated with the reference impedance  $Z_R$ , shall be greater than or equal to -1 dB.

NOTE: The minimum SLR value of -1 dB refers to the actual measured value rather than the nominal value, i.e. there is no tolerance on the specified value, and has been specified to ensure no harm to the network. It is recommended that for normal operation, the SLR should be greater than or equal to +2 dB.

**Test:** The test shall be conducted according to subclause A.2.3.

#### 4.2.3.2 Equipment with internally generated electrical signals

##### 4.2.3.2.1 Maximum mean power

**Requirement:** The mean power level in the frequency range 200 Hz to 3 800 Hz in any one minute period shall be not greater than -13 dBm when the terminal equipment interface is terminated with the reference impedance  $Z_R$ .

**Test:** The test shall be conducted according to subclause A.2.4.

##### 4.2.3.2.2 Maximum instantaneous power (peak voltage)

The maximum instantaneous power is expressed in terms of the peak voltage.

**Requirement:** The peak voltage from the terminal equipment interface shall not be greater than 1,1 volts over the frequency range 200 Hz to 3 800 Hz when the terminal equipment interface is terminated with the reference impedance  $Z_R$ .

**Test:** The test shall be conducted according to subclause A.2.5.

##### 4.2.3.2.3 Maximum power in a 10 Hz bandwidth

**Requirement:** The maximum power within a 10 Hz bandwidth centred at any frequency within the frequency band 0 Hz to 4 300 Hz, and wholly contained within that frequency band, shall not exceed the limits given in table 3 and figure 3 when the terminal equipment interface is terminated with the reference impedance  $Z_R$ .

Exceptionally, when sending DTMF tones, the maximum power in a 10 Hz bandwidth between the frequencies 1 200 Hz and 1 700 Hz shall not exceed -7 dBm.

NOTE: Generally, DTMF tones will have a duty cycle of 50 % or less.

**Table 3: Maximum power in a 10 Hz bandwidth**

Points (see fig. 3)	Frequency range kHz	Maximum sending power dBm
A	0,0	-37
B	0,03	-37
B	0,1	-20
C	0,3	-10
D	3,4	-10
E	3,8	-19
F	4,3	-44
NOTE: Limits for intermediate frequencies are found by drawing a straight line between the break points in table 3 on a logarithmic(frequency) - linear(dB) scale.		

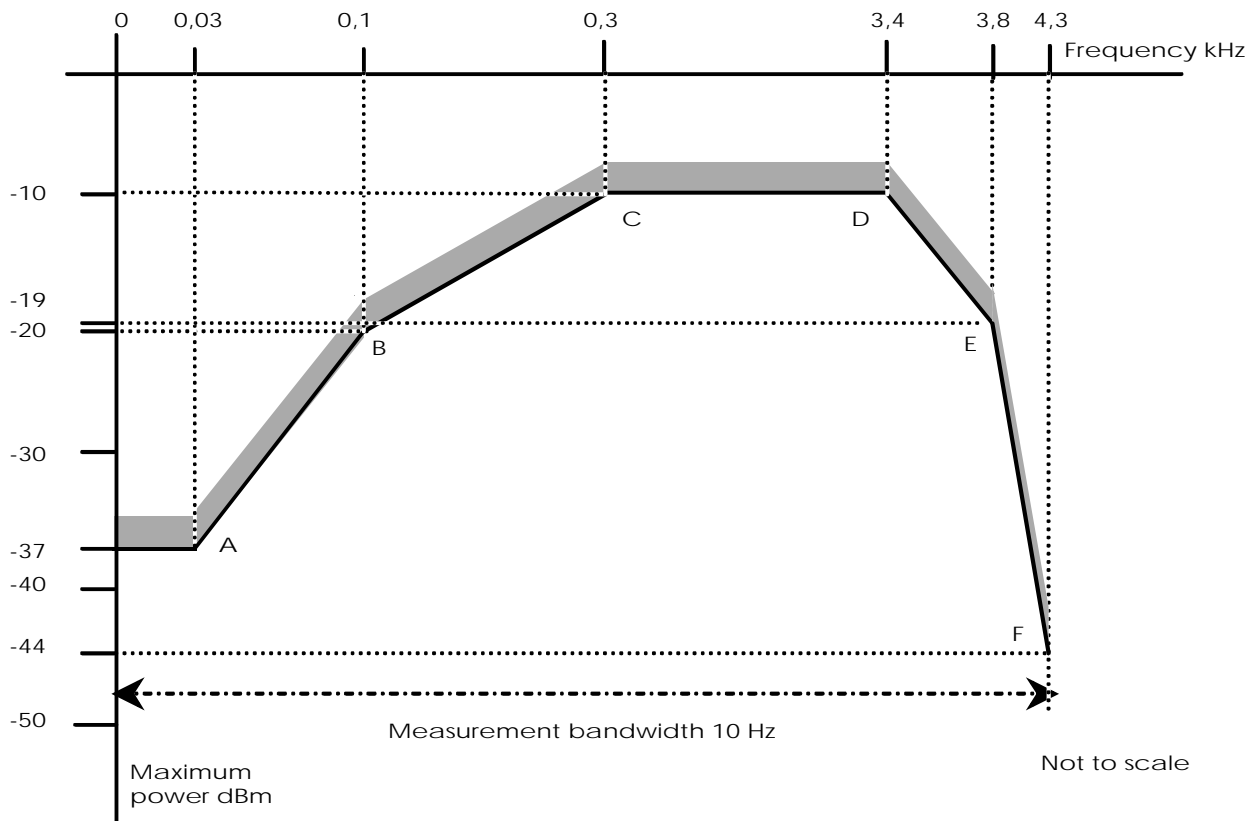

Figure 3: Maximum power in a 10 Hz bandwidth

**Test:** The test shall be conducted according to subclause A.2.6.

#### 4.2.3.3 Equipment with an electrical input

There is no requirement on the level of the output signal in the frequency range 0 Hz to 4 300 Hz where the output signal is derived from another electrical interface (e.g. by through connection).

**NOTE:** It is not practical to limit the level of signals that originate from another interface on the terminal equipment and therefore there is no requirement on this category of equipment within this ETS. It is recommended that the equipment supplier should indicate allowed input signal levels at other ports to which through connection is allowed.

#### 4.2.4 Maximum sending power above 4,3 kHz

This requirement applies to all terminal equipments. Where the output signal from the terminal equipment is derived from an acoustic interface or an electrical interface, these interfaces shall be in their quiescent states.

**Requirement:** The maximum sending power above 4,3 kHz, in a bandwidth defined in table 4 and wholly contained within the frequency range 4,3 kHz to 2 MHz, arising from normal operation of the terminal equipment when terminated with 120  $\Omega$ , shall not exceed the limits shown in table 4 and figure 4.

Exceptionally (e.g. during the sending of DTMF signals), the level of single frequency components in the output spectrum may exceed the limits given in table 4 and figure 4 but shall not exceed -35 dBm per component.

**NOTE 1:** The terminating impedance of 120  $\Omega$  is chosen for the outband requirement as this is a better approximation to the impedance seen by the terminal equipment at these frequencies.

NOTE 2: "Normal operation of the terminal equipment" is defined in the test, see subclause A.2.7.

**Table 4: Maximum sending power above 4,3 kHz**

Points (see fig. 4)	Frequency range	Maximum sending power in a specified bandwidth	Measurement bandwidth
G to H	4,3 kHz to 5 kHz	-29 dBm decreasing to -36 dBm	300 Hz
H to I	5 kHz to 7 kHz	-36 dBm decreasing to -46 dBm	300 Hz
J to K	7 kHz to 200 kHz	-41 dBm	1 kHz
L to M	200 kHz to 2 000 kHz	-45 dBm	10 kHz

NOTE: Limits for intermediate frequencies are found by drawing a straight line between the break points in table 4 on a logarithmic(frequency) - linear(dB) scale.

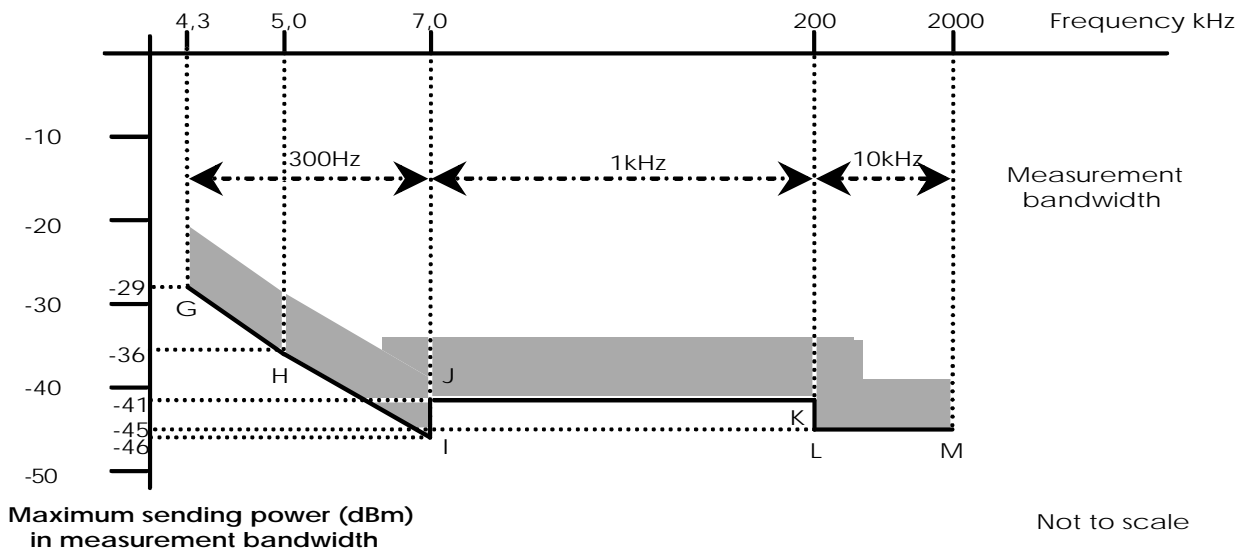

**Figure 4: Maximum sending power above 4,3 kHz**

**Test:** The test shall be conducted according to subclause A.2.7.

#### 4.2.5 Power feeding

**Requirement:** The terminal equipment interface shall not feed power to the network interface and shall not require power from the network interface.

**Test:** The test for power output to the network interface shall be conducted according to subclause A.2.8. The test for the requirement not to support power feeding from the network interface is tested indirectly through the various tests of annex A since no power is supplied over the terminal equipment interface from the test equipment.

#### 4.3 Safety

**Requirement:** The terminal equipment interface shall comply with the requirements for connection to Telecommunications Network Voltage (TNV) circuits of telecommunications networks given in clause 6 of EN 60950 [2].

**Test:** The test shall be conducted according to clause 6 of EN 60950 [2].

#### 4.4 ElectroMagnetic Compatibility (EMC)

There are no EMC requirements under this ETS.

NOTE: General EMC requirements are imposed under the EMC Directive (89/336/EEC). Requirements specific to terminal equipment will be added to this ETS when appropriate specifications become available.

## Annex A (normative): Test methods

### A.1 General

This annex describes the test principles to be used to determine the compliance of a terminal equipment against the requirements of this ETS.

It is outside the scope of this annex to identify the specific details of the implementation of the tests.

A terminal equipment may be designed for through-connecting and may fulfil the electrical requirements only if through-connected. In these cases the requirements of this ETS are valid and the tests are carried out with the through-connection terminated as specified by the manufacturer.

Details of test equipment accuracy and the specification tolerance of the test devices are not included in all cases. Where such details are provided, they shall be complied with, but the way they are expressed shall not constrain the method of implementing the test.

**NOTE:** Attention is drawn to the issue of measurement uncertainty which may be addressed in future documents. Not all the required test results make allowance for spurious events during testing (e.g. errors due to EMC effects), which may make it necessary to repeat a test.

The test configurations given do not imply a specific realization of test equipment or test arrangement, or the use of specific test devices for conformance testing. However, any test configuration used shall provide those test conditions specified under "interface state", "stimulus" and "monitor" for each individual test.

The test equipment shall be a device, or group of devices, that is capable of generating a stimulus signal conforming to this ETS and capable of monitoring the signal received from the interface.

#### A.1.1 Equipment connection

The tests in this ETS shall be carried out using the connection method provided in accordance with subclause 4.1. Where more than one connection method is provided, the testing shall be performed using the connection method preferred by the equipment supplier.

#### A.1.2 Reference impedance

Where the test defines the use of the reference impedance ( $Z_R$ ), this shall be a non-reactive resistance of  $600 \Omega \pm 0,25 \%$ .

#### A.1.3 Non-reactive termination

Where the test defines the use of a termination impedance ( $Z_T$ ) of  $120 \Omega$ , this shall be a non-reactive resistance of  $120 \Omega \pm 0,25 \%$ .

### A.2 Test methods

One test may cover more than one requirement. The scope of each test is defined under the heading "purpose".

#### A.2.1 Return loss

**Requirement:** Subclause 4.2.1.

**Purpose:** To measure the return loss of both the input and output ports of the terminal equipment interface with respect to the reference impedance  $Z_R$ .

**Test configuration:** The terminal equipment is connected as shown in figure A.1.

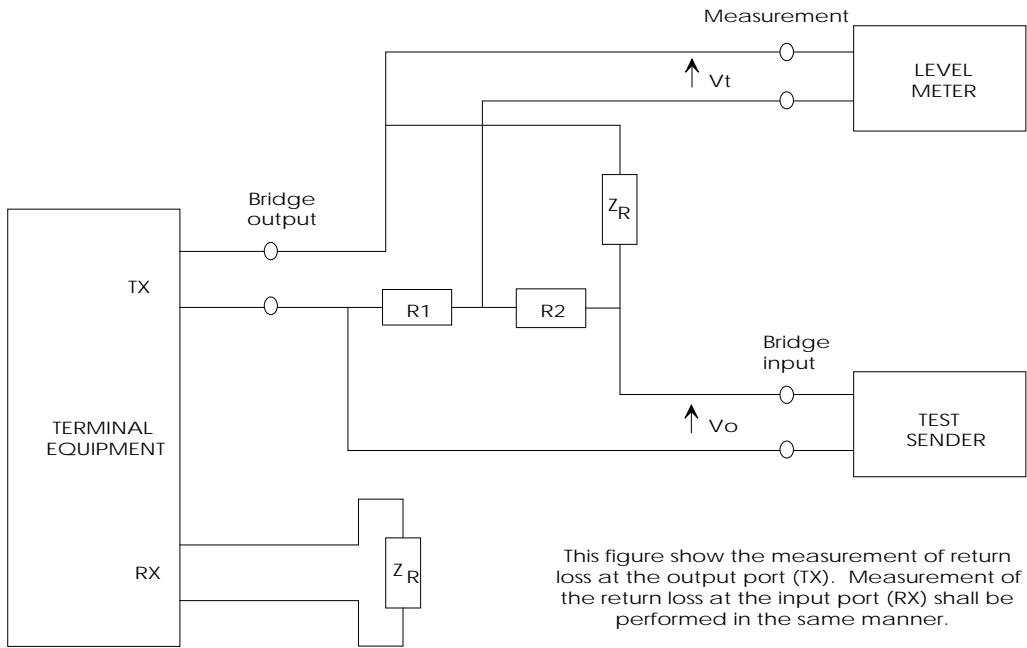

R1 = R2; between 100 Ω and 800 Ω, preferably 600 Ω, matched to better than 0,2 %  
 Test sender output impedance < 10 Ω

**Figure A.1: Return loss**

- Interface state:** Powered.
- Stimulus:** A sinusoidal signal with a constant voltage is applied to the input of the bridge at various frequencies between 300 Hz and 3 400 Hz. The constant voltage is that required to give a power level of -13 dBm at 1 020 Hz into a reference impedance connected to the output of the bridge. Each measurement frequency shall be spaced by not more than one third of an octave from the next frequency of measurement.
- Monitor:** The level of voltages  $V_o$  and  $V_t$  with the terminal equipment port connected to the output of the bridge, as shown in figure A.1. The voltage measurement is conducted using suitable high impedance measuring equipment.
- Result:** The return loss  $a$  of both the input and output ports shall meet the requirement of subclause 4.2.1 across the frequency range, where:

$$a = 20 \log \left| \frac{V_o}{2V_t} \right| \text{dB}$$

where  $V_o$  is the test signal level  
 and  $V_t$  is the level measured across the bridge.

**A.2.2 Longitudinal conversion loss**

- Requirement:** Subclause 4.2.2.
- Purpose:** To measure the longitudinal conversion loss of both the input and output ports of the terminal equipment interface.

NOTE: The test is based on the method defined in CCITT Recommendation O.9.



Test configuration: Figure A.2.

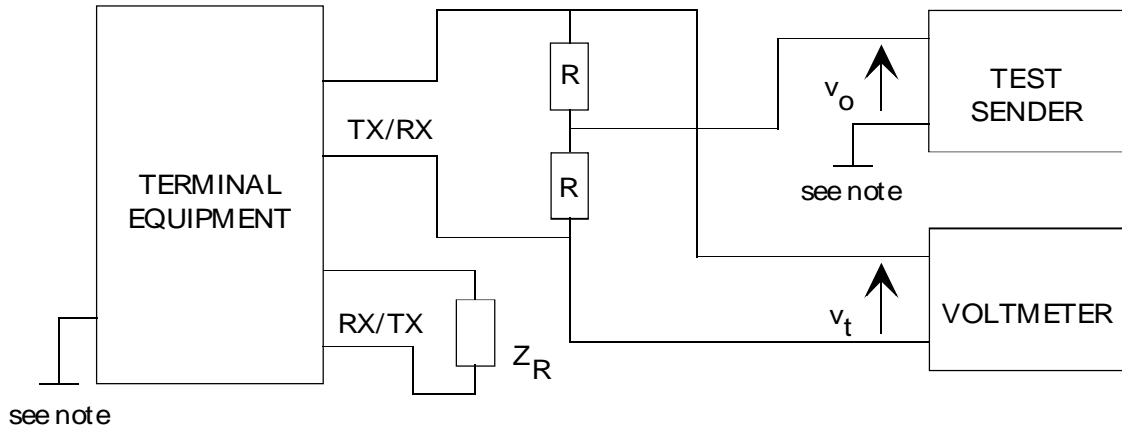

The resistors R shall be  $300 \Omega \pm 1 \%$  and matched to better than 0,1 %.  
 The test sender output impedance is not critical.

NOTE: This point shall be connected to the terminal equipment common reference point or test reference point. In the absence of such a connection point, this shall be a 1 m square copper plate upon which the terminal equipment shall rest.

**Figure A.2: Longitudinal conversion loss**

**Interface state:** Powered.

**Stimulus:** The test sender is swept through the specified frequency range with its output voltage  $V_o$  kept constant at 775 mV rms. Measurement of the longitudinal voltage  $V_t$  is performed with a suitable frequency selective level measuring instrument.

**Monitor:** The maximum value of  $V_t$  for both the input and output ports. These values are used to calculate the minimum value of longitudinal conversion loss from the equation:

$$\text{Longitudinal conversion loss} = 20 \log \left| \frac{V_o}{V_t} \right| \text{dB}$$

**Result:** The longitudinal conversion loss in dB of both the input and output ports shall be greater than or equal to the figures shown in table 2 and figure 2.

### A.2.3 Sending Loudness Rating (SLR)

**Requirement:** Subclause 4.2.3.1.1.

**Purpose:** To check the SLR of the terminal equipment. The test consists of the performance of a sending sensitivity test at various frequencies and calculating the SLR from the results of the test.

**Test configuration:** Figure A.3.

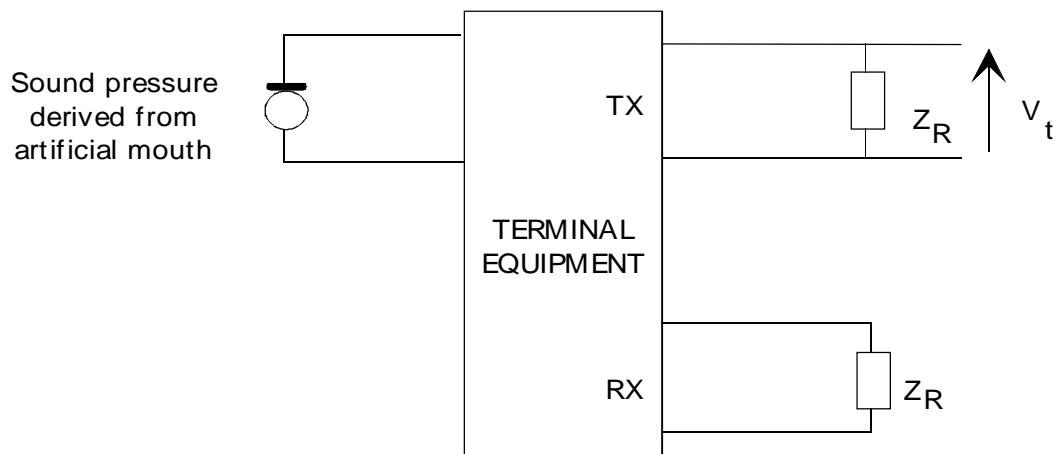

**Figure A.3: Measurement of sending sensitivity**

- Interface state:** Powered.
- Stimulus:** An acoustic signal at one of the frequencies shown in table A.1 and at a sound pressure level of -4,7 dBPa.
- Monitor:** The output voltage  $V_t$  measured at the fundamental frequency of the stimulus. The sending sensitivity  $S_{mJ}$  is determined using the method described in clause 9 of ITU-T Recommendation P.64 [4] and, where carbon microphones are involved, in annex B of ITU-T Recommendation P.64 [4].
- Result:** The value of the SLR, derived as stated below, shall be in accordance with the requirement of subclause 4.2.3.1.1.

The sending sensitivity  $S_{mJ}$  at a specified frequency or in a narrow frequency band is expressed as follows:

$$S_{mJ} = 20 \log \frac{V_t}{p_m} \text{ dB, relative to 1 V/Pa}$$

where  $V_t$  is the voltage across the termination

and  $p_m$  is the sound pressure at the mouth reference point.

The SLR is derived from the measurements of  $S_{mJ}$  obtained at the 14 frequencies shown in table A.1 from the formula:

$$\text{SLR} = -\frac{10}{0,175} \log \sum_{n=1}^{14} 10^{0,0175(S_{mJn} - W_{sn})}$$

where  $W_{sn}$  is the sending weighting factor given in table A.1

and  $S_{mJn}$  is the measured sending sensitivity at frequency  $f_n$ .

Table A.1: Parameters required to calculate SLR

Item n	Frequency $f_n$ Hz	Sending weighting factor $W_{sn}$ dB
1	200	76,9
2	250	62,6
3	315	62,0
4	400	44,7
5	500	53,1
6	630	48,5
7	800	47,6
8	1 000	50,1
9	1 250	59,1
10	1 600	56,7
11	2 000	72,2
12	2 500	72,6
13	3 150	89,2
14	4 000	117,0

NOTE: The values of  $W_{sn}$  are taken from table 2 of ITU-T Recommendation P.79 and reduced by 0,3 dB to take into account the reduced measurement bandwidth.

#### A.2.4 Maximum mean power

**Requirement:** Subclause 4.2.3.2.1.

**Purpose:** To check the maximum mean power from terminal equipments where the output signal is generated internally within the terminal equipment.

**Test configuration:** Figure A.4.

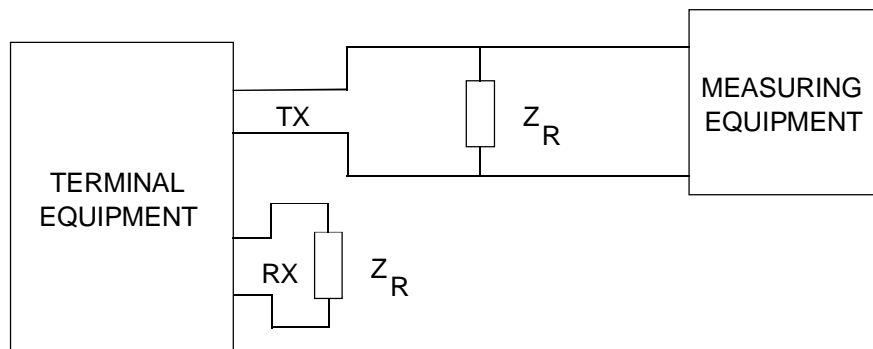

Figure A.4: Maximum mean power

**Interface state:** Powered.

**Stimulus:** Terminal equipment with adjustable output level is set up in accordance with the manufacturer's instructions for intended use, or, in the absence of instructions, is set to send at its maximum level. The terminal equipment is then operated in accordance with its intended use. For data equipment (e.g. modems), any output signal may be a test message consisting of a representative bit pattern or a scrambled signal.

For answering machines or similar equipment where the output is derived from recorded speech, any recorded signal shall have been prepared in accordance with the manufacturer's instructions for intended use.

Where a terminal equipment is transmitting DTMF tones, there shall be no more than 20 digits in each one minute period, with each digit being less than 500 ms duration and the digits separated by a period greater than 500 ms.

**Monitor:** The mean power level integrated over a one minute period. When measuring recorded or synthetic speech or music, the test shall be performed with a measuring instrument in accordance with ITU-T Recommendation P.56 [3], using method B.

**Result:** The maximum mean power in any one minute period shall not exceed the requirement defined in subclause 4.2.3.2.1.

#### A.2.5 Maximum instantaneous power (peak voltage)

**Requirement:** Subclause 4.2.3.2.2.

**Purpose:** To check the maximum instantaneous power, specified in terms of a peak voltage, from terminal equipments where the output signal is generated internally within the terminal equipment.

**Test configuration:** See figure A.5.

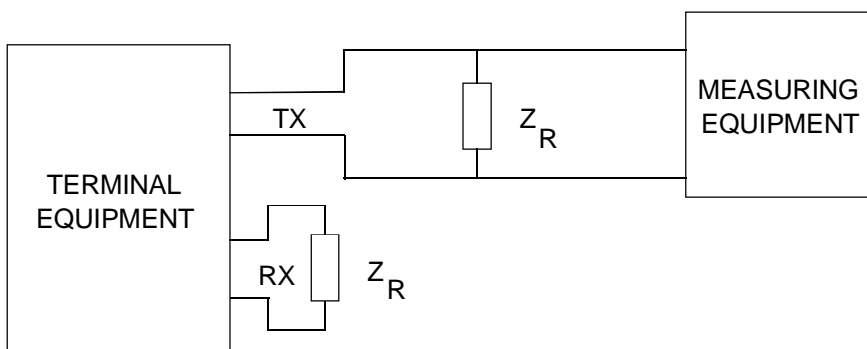

Figure A.5: Maximum instantaneous power

**Interface state:** Powered.

**Stimulus:** Terminal equipment with adjustable output level is set up in accordance with the manufacturer's instructions for intended use, or, in the absence of instructions, is set to send at its maximum level. The terminal equipment is then operated in accordance with its intended use. For data equipment (e.g. modems), any output signal may be a test message consisting of a representative bit pattern or a scrambled signal.

For answering machines or similar equipment where the output is derived from recorded speech, any recorded signal shall have been prepared in accordance with the manufacturer's instructions for intended use.

Where a terminal equipment is transmitting DTMF tones, there shall be no more than 20 digits in each one minute period, with each digit being less than 500 ms duration and the digits separated by a period greater than 500 ms.

**Monitor:** The maximum instantaneous voltage level from the terminal equipment, using measuring equipment which has a rise time less than 50  $\mu$ s and a detection bandwidth of at least 200 Hz to 3 800 Hz.

**Result:** The maximum instantaneous voltage level shall not exceed the requirement defined in subclause 4.2.3.2.2.

### A.2.6 Maximum power in a 10 Hz bandwidth

**Requirement:** Subclause 4.2.3.2.3.

**Purpose:** To check the maximum power in a 10 Hz bandwidth from terminal equipments where the output signal is generated internally within the terminal equipment.

**Test configuration:** See figure A.6.

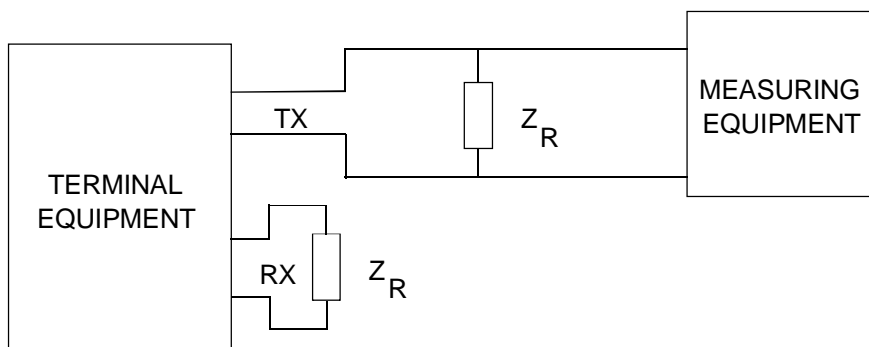

**Figure A.6: Maximum signal power in a 10 Hz bandwidth**

**Interface state:** Powered.

**Stimulus:** Terminal equipment with adjustable output level is set up in accordance with the manufacturer's instructions for intended use, or, in the absence of instructions, is set to send at its maximum level. The terminal equipment is then operated in accordance with its intended use. For data equipment (e.g. modems), any output signal may be a test message consisting of a representative bit pattern or a scrambled signal.

For answering machines or similar equipment where the output is derived from recorded speech, any recorded signal shall have been prepared in accordance with the manufacturer's instructions for intended use.

Where the terminal equipment is capable of sending DTMF tones, these tones shall be sent continuously where this is supported by the terminal equipment, otherwise DTMF digits shall be sent at the maximum rate allowed.

**Monitor:** The maximum power from the terminal equipment in a 10 Hz bandwidth at any frequency within the frequency band 25 Hz to 4 300 Hz and wholly contained within that frequency band. In the case of data equipment (e.g. modems), the maximum power shall only be measured during the data transfer phase.

**Result:** The maximum power in any 10 Hz bandwidth shall not exceed the requirements stated in table 3 and figure 3 of subclause 4.2.3.2.3. Exceptionally, when testing with DTMF tones, the maximum power in a 10 Hz bandwidth between the frequencies 1 200 Hz and 1 700 Hz shall not exceed -7 dBm.

### A.2.7 Maximum sending power above 4,3 kHz

**Requirement:** Subclause 4.2.4.

**Purpose:** The test is used to measure the maximum sending power above 4,3 kHz, irrespective of where the output signal is derived from.

**Test configuration:** Figure A.7.

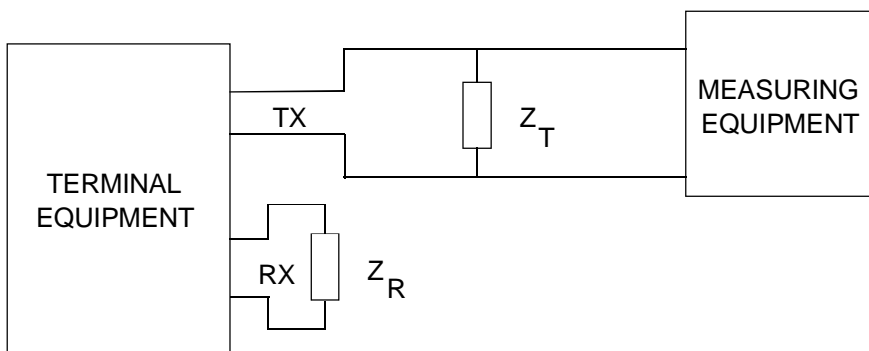

**Figure A.7: Maximum sending power above 4,3 kHz**

**Interface state:** Powered.

**Stimulus:** Terminal equipment with adjustable output level is set up in accordance with the manufacturer's instructions for intended use, or, in the absence of instructions, is set to send at its maximum level. The terminal equipment is then operated in accordance with its intended use. For data equipment (e.g. modems), any output signal may be a test message consisting of a representative bit pattern or a scrambled signal.

For answering machines or similar equipment where the output is derived from recorded speech, any recorded signal shall have been prepared in accordance with the manufacturer's instructions for intended use.

Where the terminal equipment is capable of sending DTMF tones, these tones shall be sent continuously where this is supported by the terminal equipment, otherwise DTMF digits shall be sent at the maximum rate allowed.

For terminal equipment where the output signal is derived in real time from an acoustic interface, the input signal to the acoustic interface shall be in a quiescent state.

For through connecting terminal equipment where the output signal is derived from another electrical interface, the input signal to the electrical interface shall be in a quiescent state.

**Monitor:** The power over the frequency range 4,3 kHz to 2 000 kHz across the terminating impedance ( $Z_T$ ) of 120  $\Omega$ , using a bandwidth as specified in table A.2 which shall be wholly contained within the specified frequency range.

**Table A.2: Measurement bandwidth for maximum sending power above 4,3 kHz**

Frequency range	Measurement bandwidth
4,3 kHz to 7 kHz	300 Hz
7 kHz to 200 kHz	1 kHz
200 kHz to 2 000 kHz	10 kHz

**Result:** The maximum sending power above 4,3 kHz shall not exceed the limits shown in table 4 and figure 4. Exceptionally (e.g. during the sending of DTMF signals), the level of single frequency components in the output spectrum may exceed the limits given in table 4 and figure 4 but shall not exceed -35 dBm per component.

### A.2.8 Power feeding

**Requirement:** Subclause 4.2.5.

**Purpose:** To verify that the terminal equipment is not designed for power feeding by measuring the output current from the terminal equipment into an resistance of 300  $\Omega$ .

**Test configuration:** See figure A.8.

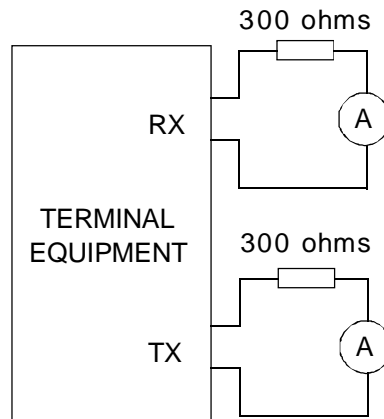

**Figure A.8: Power feeding**

**Interface state:** Powered.

**Stimulus:** None.

**Monitor:** The current through a resistance of 300  $\Omega$  connected to each pair.

**Result:** The current through each 300  $\Omega$  shall be less than 1 mA.

## **Annex B (informative): Bibliography**

- 89/336/EEC: "Council Directive of 3 May 1989 on the approximation of the laws of Member States relating to electromagnetic compatibility".
- 91/263/EEC: "Council Directive of 29 April 1991 on the approximation of the laws of Member States concerning telecommunications terminal equipment, including the mutual recognition of their conformity".
- 92/44/EEC: "Council Directive of 5 June 1992 on the application of Open Network Provision to leased lines".
- CCITT Recommendation M.1020 (1988): "Characteristics of special quality international leased circuits with special bandwidth conditioning".
- CCITT Recommendation M.1040 (1988): "Characteristics of ordinary quality international leased circuits".
- CCITT Recommendation O.9 (1988): "Measurement arrangements to assess the degree of unbalance about earth".
- ITU-T Recommendation P.79 (1993): "Calculation of loudness ratings for telephone sets".
- ETS 300 451: "Business TeleCommunications (BTC); Ordinary quality voice bandwidth 4-wire analogue leased line (A4O); Connection characteristics and network interface presentation".
- ETS 300 452: "Business TeleCommunications (BTC); Special quality voice bandwidth 4-wire analogue leased line (A4S); Connection characteristics and network interface presentation".
- TBR 17: "Business TeleCommunications (BTC); Ordinary and Special quality voice bandwidth 4-wire analogue leased lines (A4O and A4S); Attachment requirements for terminal equipment interface".



## History

Document history			
September 1994	Public Enquiry	PE 70:	1994-09-05 to 1994-12-30
November 1995	Vote	V 92:	1995-11-27 to 1996-01-19
February 1996	First Edition		