



EUROPEAN
TELECOMMUNICATION
STANDARD

DRAFT
pr **ETS 300 448**

September 1994

Source: ETSI TC-BTC

Reference: DE/BTC-02027

ICS: 33.020, 33.040.40

Key words: ONP, leased line

**Business TeleCommunications (BTC);
Ordinary quality voice bandwidth
2-wire analogue leased line (A2O)
Connection characteristics and network interface presentation**

ETSI

European Telecommunications Standards Institute

ETSI Secretariat

Postal address: F-06921 Sophia Antipolis CEDEX - FRANCE

Office address: 650 Route des Lucioles - Sophia Antipolis - Valbonne - FRANCE

X.400: c=fr, a=atlas, p=etsi, s=secretariat - **Internet:** secretariat@etsi.fr

Tel.: +33 92 94 42 00 - Fax: +33 93 65 47 16

Copyright Notification: No part may be reproduced except as authorized by written permission. The copyright and the foregoing restriction extend to reproduction in all media.

© European Telecommunications Standards Institute 1994. All rights reserved.

Contents

Foreword	5
Introduction	5
1 Scope	7
2 Normative references	7
3 Definitions and abbreviations	8
3.1 Definitions	8
3.2 Abbreviations	8
4 Requirements	9
4.1 Connection characteristics	9
4.1.1 Tabulation of connection characteristics	9
4.1.2 Overall loss	9
4.1.3 Loss/frequency distortion	10
4.1.4 Transmission signals	10
4.1.4.1 Maximum mean input power	10
4.1.4.2 Maximum instantaneous power	11
4.1.4.3 Maximum power in a 10 Hz bandwidth	11
4.1.4.4 Maximum input power outside the voice band	11
4.1.5 Transmission delay	11
4.1.6 Group delay distortion	12
4.1.7 Variation of overall loss with time	12
4.1.7.1 Amplitude hits	12
4.1.7.2 Other variations	12
4.1.8 Random circuit noise	13
4.1.9 Impulsive noise	13
4.1.10 Phase jitter	13
4.1.11 Distortion	13
4.1.11.1 Quantizing distortion	13
4.1.11.2 Total distortion	13
4.1.12 Single tone interference	13
4.1.13 Frequency error	13
4.1.14 Harmonic distortion	13
4.1.15 Echo and stability	13
4.1.15.1 Echo	13
4.1.15.1.1 Echo control devices	13
4.1.15.1.2 Talker echo	14
4.1.15.1.3 Listener echo	14
4.1.15.2 Stability	14
4.2 Interface presentation	14
4.2.1 Connector specification	14
4.2.2 Hardwired presentation	15
4.2.3 Return loss	15
4.2.4 Power feeding	15
4.3 Safety	15
4.4 Overvoltage protection	16
4.5 Electro-magnetic compatibility	16
Annex A (normative): Test methods	17
A.1 General	17
A.1.1 Equipment connection	17
A.1.2 Reference impedance	17
A.1.3 Non-reactive line termination	17

A.1.4	Measurement frequency	18
A.2	Test methods.....	18
A.2.1	Tests of connection characteristics.....	18
A.2.1.1	Overall loss	18
A.2.1.2	Loss/frequency distortion and maximum mean input power	18
A.2.1.3	Maximum instantaneous power	19
A.2.1.4	Random circuit noise	20
A.2.1.5	Stability	20
A.2.2	Tests for interface presentation.....	21
A.2.2.1	Return loss.....	21
A.2.2.2	Power feeding.....	22
Annex B (informative):	Weighted return loss measurements.....	23
B.1	Introduction.....	23
B.2	Weighting function.....	23
B.2.1	Calculation (trapezoidal rule).....	23
B.2.2	Calculation (tabulated data)	24
Annex C (informative):	Bibliography	25
History		26

Foreword

This draft European Telecommunication Standard (ETS) has been produced by the Business Telecommunications (BTC) Technical Committee of the European Telecommunications Standards Institute (ETSI), and is now submitted for the Public Enquiry phase of the ETSI standards approval procedure.

This ETS resulted from a mandate from the Commission of the European Community (CEC) to provide harmonized standards for support of the Directive on Open Network Provision (ONP) of leased lines (92/44/EEC).

There is another standard directly related to this ETS:

ETS 300 450: "Business Telecommunications (BTC); Ordinary and Special quality voice bandwidth 2-wire analogue leased lines (A2O and A2S); Terminal equipment interface".

This ETS is based on information from CCITT Recommendations and ETSI publications and the relevant documents are quoted where appropriate.

Proposed transposition dates	
Date of latest announcement of this ETS (doa):	3 months after ETSI publication
Date of latest publication of new National Standard or endorsement of this ETS (dop/e):	6 months after doa
Date of withdrawal of any conflicting National Standard (dow):	6 months after doa

Introduction

The Council Directive on the application of Open Network Provision to leased lines (92/44/EEC) concerns the harmonization of conditions for open and efficient access to, and use of, the leased lines provided over public telecommunication networks, and the availability throughout the Community (EEC) of a minimum set of leased lines with harmonized technical characteristics.

The consequence of the Directive is that Telecommunications Organizations within the EEC shall make available a set of leased lines within and between points in these countries with specified connection characteristics and specified interfaces. Under the Second Phase Directive (91/263/EEC) terminal equipment for connection to these leased lines will be required to fulfil certain essential requirements.

CCITT Recommendation M.1040 (1988) is used as the basis for the connection characteristics.

Blank page

1 Scope

This European Telecommunication Standard (ETS) specifies the technical requirements and test principles for the connection characteristics and the physical and electrical characteristics of the network interface presentation of ordinary quality, voice bandwidth, 2-wire, analogue leased lines, provided as part of the minimum set under the Council Directive on the application of Open Network Provision (ONP) to leased lines (92/44/EEC).

A connection is presented via interfaces at Network Termination Points (NTP) and includes any equipment that may provide the NTP. Signals between terminal equipments are subject to impairments during their transfer over the connection. The limits to these impairments are stated in this ETS. This ETS describes the service offered.

The leased line provides access to the voice bandwidth (300 Hz to 3 400 Hz) with no restrictions on the use of the frequencies.

This ETS is applicable for leased lines, including part time leased lines, for which the establishment or release does not require any protocol exchange or other intervention at the NTP.

The tests specified in this ETS cannot be carried out, nor can performance be monitored by the leased line provider, while the leased line is in service, i.e. carrying user's traffic. Thus the tests are designed for bringing into and returning into service although there is no obligation to perform these tests each time the leased line is brought into or returned into service.

This ETS covers the physical, mechanical and electrical characteristics of the network interface and specifies the conformance tests for the connection characteristics and network interface. Some of the tests described in this ETS are not designed to be applied to the interface of an installed leased line; such tests may be applied to equipment of the kind used to provide the interface.

This ETS does not include details concerning the implementation of the tests nor does it include information on any regulations concerning testing.

2 Normative references

This ETS incorporates by dated and undated reference, provisions from other publications. These normative references are cited at the appropriate places in the text and the publications are listed hereafter. For dated references, subsequent amendments to or revisions of any of these publications apply to this ETS only when incorporated in it by amendment or revision. For undated references the latest edition of the publication referred to applies.

- [1] CCITT Recommendation O.41 (1988): "Psophometer for use on telephone-type circuits".
- [2] EN 28877 (1989): "Information processing systems - Interface connector and contact assignments for ISDN basic access interface located at reference points S and T".
- [3] EN 60950 (1992): "Safety of information technology equipment including electrical business equipment".

NOTE: This ETS also contains a number of informative references which have been included to indicate the sources from which material has been derived, hence they do not have an associated normative reference number. Details of these publications are given in Annex C. In some cases the same publication may have been referenced in both a normative and an informative manner.

3 Definitions and abbreviations

3.1 Definitions

For the purposes of this ETS, the following definitions apply:

Group delay: a measure of the propagation time through the leased line. For a given frequency it is equal to the first derivative of the phase shift through the leased line, measured in radians, with respect to the angular frequency measured in radians per second.

Group delay distortion: the difference between group delay at a given frequency and minimum group delay, in the frequency band of interest.

Leased lines: the telecommunications facilities provided by a public telecommunication network that provide defined transmission characteristics between network termination points and that do not include switching functions that the user can control, (e.g. on-demand switching).

Network Termination Point (NTP): all physical connections and their technical access specifications which form part of the public telecommunication network and are necessary for access to and efficient communication through that public network.

Reference impedance Z_R : this is a complex impedance made up of a resistance of 275 Ω in series with a parallel combination of 850 Ω and 150 nF. See also Annex A, subclause A.1.2.

Terminal Equipment (TE): equipment intended to be connected to the public telecommunication network; i.e.:

- a) to be connected directly to the termination of a public telecommunication network; or
- b) to interwork with a public telecommunication network being connected directly or indirectly to the termination of a public telecommunication network,

in order to send, process, or receive information.

Voice bandwidth: the band of frequencies over which the communication of voice signals takes place. For the purpose of this ETS, this is defined to be the range 300 Hz to 3 400 Hz.

3.2 Abbreviations

For the purposes of this ETS, the following abbreviations apply:

a	Return loss in dB
$a(f)$	Return loss at frequency f in dB
a_w	Weighted return loss in dB
$A(f)$	Return loss at frequency f expressed as a ratio
A2O	Ordinary quality voice bandwidth 2-wire analogue leased line
ADPCM	Adaptive Differential Pulse Coded Modulation
d.c.	direct current
EMC	Electro-Magnetic Compatibility
f	frequency
NTP	Network Termination Point
ONP	Open Network Provision
QDU	Quantizing Distortion Unit
rms	root mean square
TE	Terminal Equipment
TNV	Telecommunication Network Voltage (see EN 60950 [3], subclause 3.4)
Z_R	Reference impedance

4 Requirements

4.1 Connection characteristics

The ordinary quality voice bandwidth 2-wire analogue leased line is a bidirectional line, configured point-to-point, nominally covering the voice bandwidth. The connection is, in general, symmetrical, i.e. each direction of transmission has the same nominal characteristics, although the actual values are independent.

4.1.1 Tabulation of connection characteristics

The parameters defining the characteristics of the connection are given in table 1. These characteristics define the service offered.

Table 1: Network performance characteristics

Description	Nature	Reference subclause
Overall loss	$0 \leq \text{Overall loss} \leq 25 \text{ dB}$	4.1.2
Loss/frequency distortion	Table 2, figure 1	4.1.3
Transmission signals		4.1.4
- maximum mean input power	-9 dBm	4.1.4.1
- maximum instantaneous power	+4 dBm	4.1.4.2
- maximum power in a 10 Hz bandwidth	no requirement	4.1.4.3
- maximum input power outside voice band	no requirement	4.1.4.4
Transmission delay		4.1.5
- terrestrial (for distance G in kilometres)	$< (15 + 0,01 G) \text{ ms}$	
- via satellite	$< 350 \text{ ms}$	
Group delay distortion	no requirement	4.1.6
Variation of overall loss with time		4.1.7
- amplitude hits	no requirement	4.1.7.1
- other variations	$\pm 4 \text{ dB}$ of that at 1 020 Hz	4.1.7.2
Random circuit noise	$< -41 \text{ dBm0p}$ (see NOTE)	4.1.8
Impulsive noise	no requirement	4.1.9
Phase jitter	no requirement	4.1.10
Total distortion		4.1.11
- quantizing distortion	$\leq 7,5 \text{ QDU}; \leq 1 \text{ ADPCM system}$	4.1.11.1
- total distortion	no requirement	4.1.11.2
Single tone interference	no requirement	4.1.12
Frequency error	no requirement	4.1.13
Harmonic distortion	no requirement	4.1.14
Echo and stability		4.1.15
- Echo control devices	no echo control	4.1.15.1.1
- Talker echo	$< 10 \text{ dB}$	4.1.15.1.2
- Listener echo	$< 20 \text{ dB}$	4.1.15.1.3
- Stability	0 to 4 kHz	4.1.15.2
NOTE:	Where the output relative level is not defined, an alternative value is specified in the reference subclause.	

4.1.2 Overall loss

Requirement: The overall loss, including long term variations, presented to a signal frequency of 1 020 Hz sent at a power level of -9 dBm in each direction of transmission with the line terminated in 600 Ω at each end shall be in the range:

$$0 \leq \text{Overall loss} \leq 25 \text{ dB.}$$

NOTE: The overall loss in each direction can be different.

Test: The test shall be conducted according to Annex A, subclause A.2.1.1.

4.1.3 Loss/frequency distortion

Requirement: The overall loss relative to that defined in subclause 4.1.2 above for the connection, presented to a signal sent at a power level of -9 dBm with the line terminated in 600 Ω at each end shall lie between the limits given in table 2 and figure 1.

NOTE: Figure 1 is based on figure 1/M.1040.

Below 300 Hz and above 3 600 Hz the loss shall not be less than 0 dB, but is otherwise unspecified.

Table 2: Limits for loss of the circuit relative to that at 1 020 Hz

Upper limit			Lower limit		
Point	Frequency Hz	Relative loss dB	Point	Frequency Hz	Relative loss dB
A	400	9	E	300	0
B	2 000	9	F	300	-3
C	2 000	16	G	3 600	-3
D	2 800	16	H	3 600	0

Relative loss dB

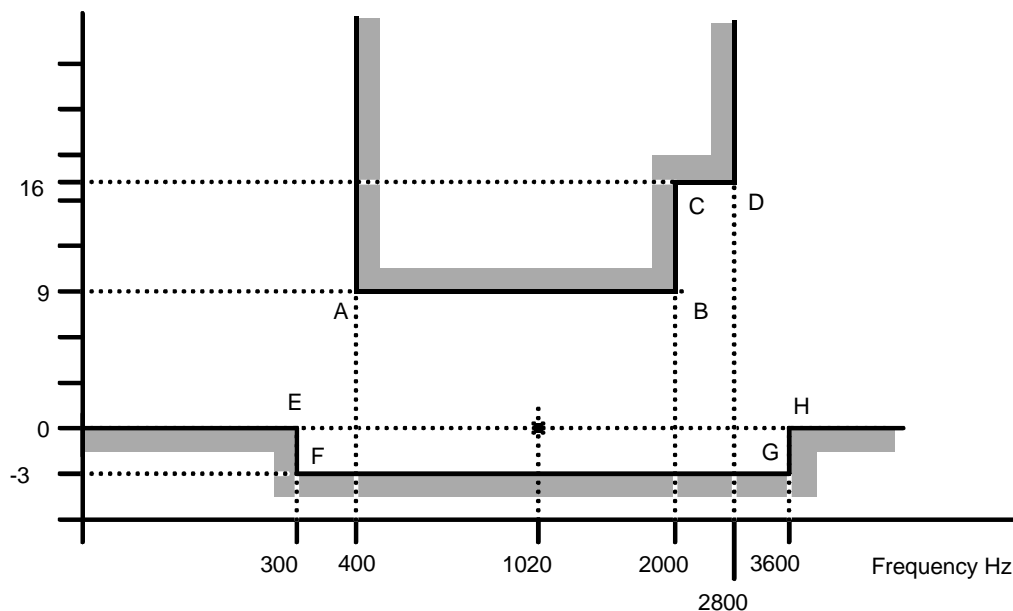

Figure 1: Limits for loss of the circuit relative to that at 1 020 Hz

Test: The test shall be conducted according to Annex A, subclause A.2.1.2.

4.1.4 Transmission signals

4.1.4.1 Maximum mean input power

Requirement: The leased line shall be capable of carrying any signal presented at the input at a one minute mean power level of -9 dBm within a voice bandwidth of 300 Hz to 3 400 Hz with the line terminated in 600 Ω at each end.

Test: The test shall be conducted according to Annex A, subclause A.2.1.2.

4.1.4.2 Maximum instantaneous power

Requirement: The leased line shall be capable of carrying a signal at the input having a maximum value equal to an instantaneous power which is 13 dB above the mean value of -9 dBm (i.e. +4 dBm).

NOTE: This value is based upon a provisional CCITT value. See CCITT Recommendation V.2.

Test: The test shall be conducted according to Annex A, subclause A.2.1.3.

4.1.4.3 Maximum power in a 10 Hz bandwidth

There is no requirement for maximum power in a 10 Hz bandwidth.

NOTE: However, there is a corresponding requirement on the terminal equipment specified in ETS 300 450.

4.1.4.4 Maximum input power outside the voice band

NOTE: The leased line interface is not suitable for the handling of signals below 300 Hz and above 3 400 Hz. Out of band signals from the terminal equipment are limited to avoid trouble in the network (see terminal equipment interface requirement ETS 300 450).

4.1.5 Transmission delay

Requirement: The requirement depends upon whether satellite transmission is involved in the connection or not:

- a) for connections where satellite transmission is not involved the one way end-to-end delay shall be less than $(15 + 0,01 G)$ ms, where G is the geographical distance in kilometres, as shown in figure 2; or
- b) for connections where satellite transmission is involved the one way end-to-end delay shall be less than 350 ms.

NOTE: Requirements a) and b) are based on CCITT Recommendation G.114, §§ 2.2 and 2.3 with suitable adjustment to requirement a) to allow for the possible use of loaded cable.

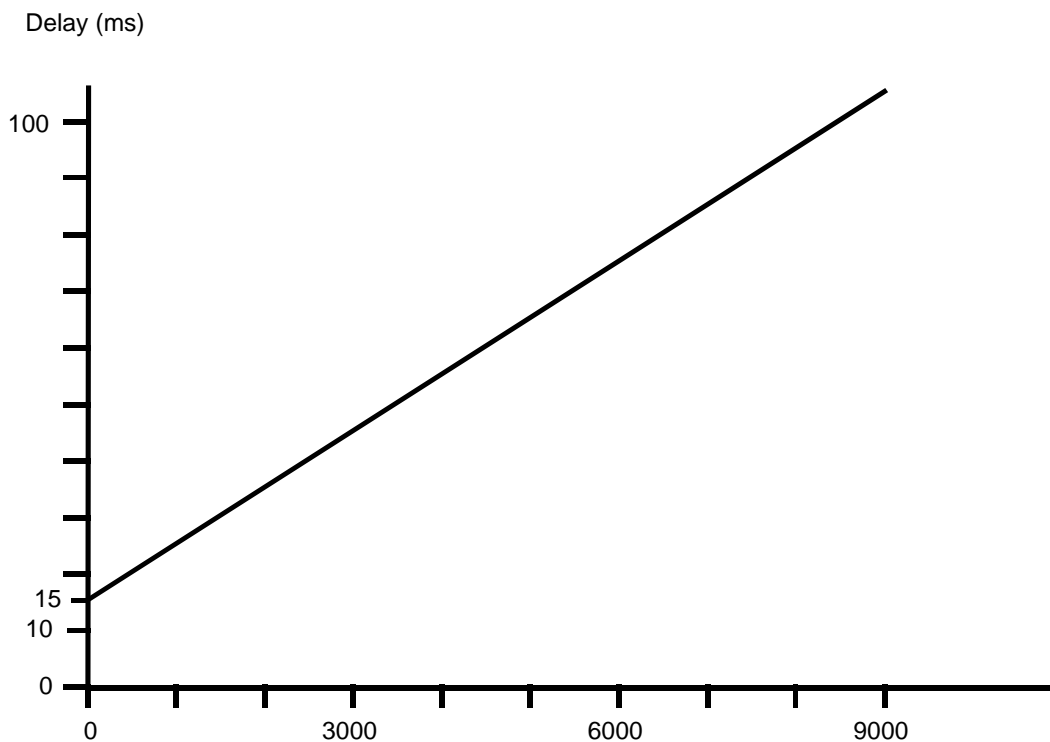

Figure 2: Upper limit of delay

Test: There is no test. This requirement shall be checked by calculation using information from the network plans.

4.1.6 Group delay distortion

There is no requirement for group delay distortion.

NOTE: Group delay distortion is not considered to be important for voice communication. Terminal equipment for other purposes which wish to make use of leased lines conforming to this ETS will need to compensate for possible shortcomings due to group delay distortion.

4.1.7 Variation of overall loss with time

4.1.7.1 Amplitude hits

There is no requirement for amplitude hits.

NOTE: Phase or amplitude hits are defined as sudden positive or negative changes in phase or amplitude of an observed test signal which exceed a specified threshold and persist for a period of time greater than a specified duration.

4.1.7.2 Other variations

Requirement: For a particular implementation, variations with time of the overall loss at 1 020 Hz (including daily and seasonal variations but excluding amplitude hits) shall not exceed ± 4 dB variation from the value established by the test for overall loss, see subclause 4.1.2. Any such variation shall not result in an overall loss greater than the maximum specified in subclause 4.1.2.

Test: There is no test for this but the record of the results of successive tests of overall loss may be used to check compliance. The test shall be conducted according to Annex A, subclause A.2.1.1.

4.1.8 Random circuit noise

Requirement: The level of the psophometric noise power at the output of the leased line shall be less than -41 dBm_{0p}. In order that this parameter can be tested, the leased line provider should declare the planned value of the output relative level of the leased line.

Where the output relative level either is not, or cannot be, declared by the leased line provider, the psophometrically weighted random circuit noise level shall be 28 dB below a received test signal which is sent at a level of -9 dBm at a frequency of 1 020 Hz into the far end of the leased line.

Test: The test shall be conducted according to Annex A, subclause A.2.1.4.

4.1.9 Impulsive noise

There is no requirement for impulsive noise.

4.1.10 Phase jitter

There is no requirement for phase jitter.

4.1.11 Distortion

4.1.11.1 Quantizing distortion

Requirement: The quantizing distortion shall not exceed 7,5 QDU. Within this limit, no more than one ADPCM system shall be used.

Test: There is no test. This requirement shall be checked by calculation using information from the network plans.

4.1.11.2 Total distortion

There is no requirement for total distortion.

4.1.12 Single tone interference

There is no requirement for single tone interference.

4.1.13 Frequency error

There is no requirement for frequency error.

4.1.14 Harmonic distortion

There is no requirement for harmonic distortion.

4.1.15 Echo and stability

4.1.15.1 Echo

4.1.15.1.1 Echo control devices

Requirement: In order to facilitate data transmission, echo control devices shall not be used in the connection.

Test: There is no test. This requirement shall be checked using information from the network plans.

4.1.15.1.2 Talker echo

Requirement: With an input signal level of -9 dBm in the frequency range 500 Hz to 2 500 Hz applied at the interface, with a source impedance of 600 Ω , any composite echo signal received at the near end interface shall be greater than 10 dB below the signal level transmitted into the interface (i.e. < -19 dBm).

Test: There is no test. This requirement shall be checked by calculation using information from the network plans.

4.1.15.1.3 Listener echo

Requirement: With an input signal level of -9 dBm in the frequency range 500 Hz to 2 500 Hz applied at the interface, with a source impedance of 600 Ω , any composite echo signal received at the far end interface shall be greater than 20 dB below the received level of the fundamental signal.

Test: There is no test. This requirement shall be checked by calculation using information from the network plans.

4.1.15.2 Stability

Requirement: Any leased line shall be stable over the frequency range 0 Hz to 4 000 Hz for all terminating conditions.

NOTE: The term "all terminating conditions" includes open and short circuit and high impedance terminations.

Test: The test shall be conducted according to Annex A, subclause A.2.1.4.

4.2 Interface presentation

The physical connection arrangements shall be by a socket; however at the request of the user and with agreement of the leased line provider, an alternative means of connection may be provided, which shall consist of a hardwired connection using insulation displacement connectors.

4.2.1 Connector specification

Requirement: Where a connector is specified as the means of terminating the leased line, the network interface shall provide an 8-contact socket of the type specified in EN 28877 [2] and with contact assignments as specified in table 3.

Table 3: Contact assignments

Contact number	Network interface
1	Unused
2	Unused
3	Unused
4 & 5	Pair
6	Unused
7	Unused
8	Unused

Test: There shall be a visual inspection that the socket is of the correct type. The contact assignments are tested indirectly through the tests in Annex A.

4.2.2 Hardwired presentation

Requirement: Where one or more leased lines are being terminated as hardwired connections, these connections shall be via an insulation displacement terminal block, suitable for terminating solid conductors having diameters in the range 0,4 to 0,6 mm, and provided by the leased line provider. The leased line provider shall provide information on the configuration of the insulation displacement terminals used for each leased line interface.

Test: There shall be a visual inspection that both an insulation displacement connector is provided suitable for taking solid conductors as defined in the requirement and that information on the configuration is provided.

NOTE: All subsequent tests are carried out via the appropriate connection method.

4.2.3 Return loss

Requirement: The return loss presented by the network interface against the reference impedance, when the far end interface of the connection is terminated by the reference impedance, shall either be:

- a) greater than 6 dB over the frequency range 300 Hz to 3 400 Hz when measured with a voltage equivalent to a signal power level at the input to the leased line of -9 dBm at 1 020 Hz; or
- b) if the return loss is not greater than 6 dB at all frequencies, then the weighted return loss against the reference impedance shall be greater than 6 dB over the frequency range 300 Hz to 3 400 Hz, when measured with a voltage equivalent to a signal power at the input to the leased line of -9 dBm at 1 020 Hz.

The weighted return loss a_w shall be given by:

$$a_w = 3,85 - 10 \log \left[\int_{300}^{3400} \frac{A(f)}{f} df \right] \text{ dB}$$

where $A(f) = 10^{-a(f)/10}$

and $a(f)$ is the measured return loss at frequency f expressed in dB.

Test: The test shall be conducted according to Annex A, subclause A.2.2.1.

4.2.4 Power feeding

Requirement: The network interface shall not be designed to support power feeding capabilities to or from the attached terminal equipment.

Test: The test for power output from the network interface shall be conducted according to Annex A, subclause A.2.2.2. The test for the requirement not to support power feeding from the terminal interface is tested indirectly through the various tests of Annex A since no power is supplied over the network interface from the test equipment.

4.3 Safety

Requirement: The leased line interface presentation shall comply with the requirements for TNV circuits and protection against electric shock given in subclause 6.2 of EN 60950 [3].

Test: The test shall be conducted according to subclause 6.2 of EN 60950 [3].

NOTE: The tests associated with the requirements in this subclause are not suitable for use on installed leased lines. Such tests may be applied to equipment of the kind used to provide the interface.

4.4 Overvoltage protection

Requirement: The leased line provider shall provide primary protection in accordance with the general practice adopted in the country in which the leased line is terminated.

NOTE: Secondary protection at the terminal equipment may be necessary to protect the terminal equipment from damage caused by overvoltages.

Test: The test provisions of the applicable national requirements shall apply.

4.5 Electro-magnetic compatibility

There are no EMC requirements under this ETS.

NOTE: EMC requirements are imposed under the EMC Directive (89/336/EEC). Requirements for conducted emissions and immunity to continuous conducted signals may be added to this ETS when appropriate specifications become available if these requirements are not imposed under the EMC directive.

Annex A (normative): Test methods

A.1 General

This annex describes the test principles to be used to determine the compliance of a leased line connection and network interface presentation against the requirements of this ETS.

It is outside the scope of this annex to identify the specific details of the implementation of the tests.

Details of test equipment accuracy and the specification tolerance of the test devices are not included in all cases. Where such details are provided, they shall be complied with, but the way they are expressed shall not constrain the method of implementing the test.

NOTE: Attention is drawn to the issue of measurement uncertainty which may be addressed in future documents. Not all the required test results make allowance for spurious events during testing (e.g. errors due to EMC effects), which may make it necessary to repeat a test.

The test configurations given do not imply a specific realization of the test equipment or test arrangement, or the use of specific test devices. However any test configuration used shall provide those test conditions specified under "interface state", "stimulus" and "monitor" for each individual test.

The test equipment shall be a device, or group of devices, that is capable of generating a stimulus signal conforming to this ETS and capable of monitoring the signal received from the interface.

A.1.1 Equipment connection

The leased line interface may be supplied with either a socket or an insulation displacement connector. Testing shall be performed at the socket or connector as this is the point at which compliance with this ETS is required.

A.1.2 Reference impedance

Where the test defines the use of the reference impedance then this shall be as follows:

Reference impedance Z_R : This is a complex impedance made up of a resistance of 275 Ω in series with a parallel combination of 850 Ω and 150 nF. This is shown in figure A.1. Specific realizations of the reference impedance required for the performance of the tests shall have a return loss against Z_R of 40 dB over the frequency range 300 Hz to 3 400 Hz.

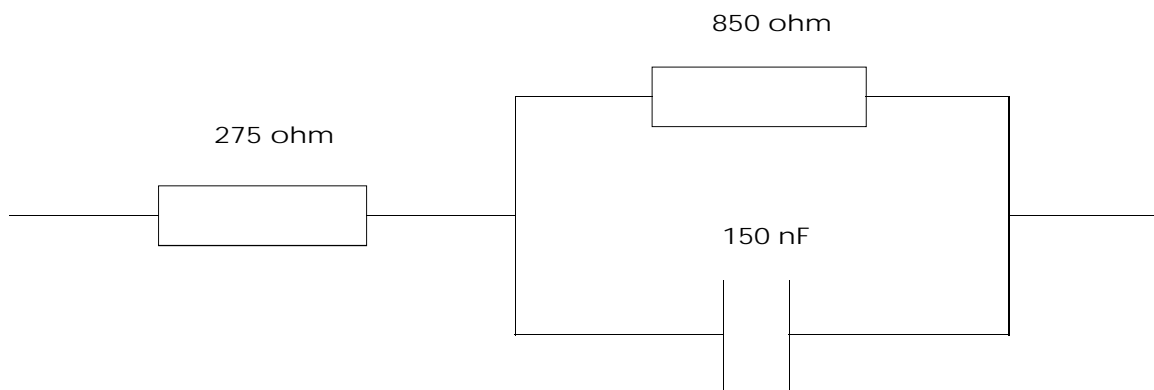

Figure A.1: Reference impedance Z_R

A.1.3 Non-reactive line termination

For all the tests specified in this annex, except the test for return loss; subclause A.2.2.1, a non-reactive line termination of 600 Ω is used. In the test for random circuit noise; subclause A.2.1.4, both impedances are used as the test assumes non-reactive line terminations in the instrumentation.

Where a line termination of 600 Ω is specified, this shall be a non-reactive resistance of 600 $\Omega \pm 0,25 \%$.

A.1.4 Measurement frequency

Many of the requirements specify a test signal frequency of 1 020 Hz. Where this is the case, the specified reference frequency tolerance shall be -7 Hz to +2 Hz (range 1 013 Hz to 1 022 Hz).

A.2 Test methods

A.2.1 Tests of connection characteristics

A.2.1.1 Overall loss

Requirement: Subclauses 4.1.2 and 4.1.7.2.

Purpose: To determine the overall loss of the leased line.

Test configuration: A test sender is connected to one interface of the leased line. A level meter is connected to the far end interface of the leased line which is terminated in 600 Ω . See figure A.2.

The test is repeated in the other direction.

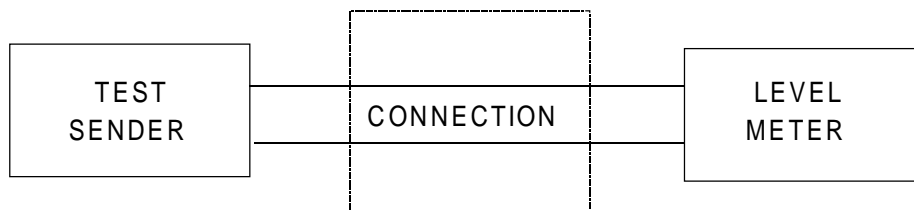

Figure A.2: Overall loss

Connection state: Available.

Stimulus: The test sender, with an impedance of 600 Ω , is set to send a single signal frequency of 1 020 Hz into a load impedance of 600 Ω at a power level of -9 dBm. The load impedance is then disconnected and the signal applied to one interface of the leased line.

Monitor: The power level is measured at the far end of the leased line with a terminating impedance of 600 Ω .

Result: The overall loss, which is the difference between -9 dBm and the measured output power, shall be as defined in subclause 4.1.2.

NOTE: For the purposes of checking the requirement of subclause 4.1.7.2 the test result may be recorded every time the test is performed during the lifetime of the leased line and the record checked for deviation from the limits set in subclause 4.1.7.2.

A.2.1.2 Loss/frequency distortion and maximum mean input power

Requirement: Subclauses 4.1.3 and 4.1.4.1.

Purpose: To check the loss/frequency distortion of the leased line over the bandwidth 300 Hz to 3 600 Hz. This test also serves to check requirement for the maximum mean input power handling capacity of the leased line interface over the frequency bandwidth 300 Hz to 3 400 Hz.

Test configuration: A test sender is connected to one interface of the leased line. A test receiver is connected to the far end interface of the leased line which is terminated in 600 Ω . See figure A.3.

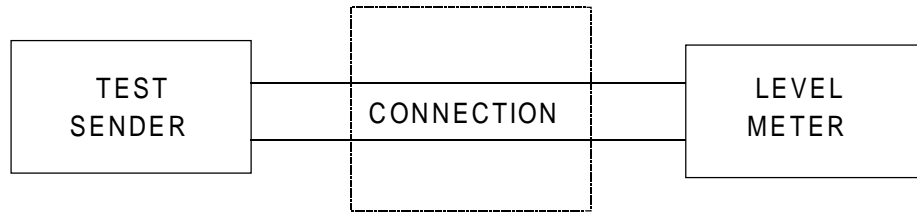

Figure A.3: Loss/frequency distortion and maximum mean input power

Connection state: Available.

Stimulus: The test sender, with an impedance of 600 Ω , is set to send a signal at a number of frequencies within the range 300 Hz to 3 600 Hz into a load impedance of 600 Ω at a power level of -9 dBm. At each frequency in turn, the load impedance is disconnected and the signal applied to one interface of the leased line.

Monitor: The power level is measured at the far end of the leased line with a terminating impedance of 600 Ω .

Result: Relative to the received level measured in subclause A.2.1.1 the received levels at other frequencies shall be within the limits defined by table 2 and figure 1.

A.2.1.3 Maximum instantaneous power

Requirement: Subclause 4.1.4.2.

Purpose: To verify that the leased line can carry a signal corresponding to the peak value of a +4 dBm signal at the input. A single cycle of a sine wave of 1 020 Hz, equivalent to +4 dBm, is transmitted into the leased line, there should be no clipping at the output. By requiring > 50 ms between cycles, the one minute mean signal level should not be exceeded.

Test configuration: See figure A.4.

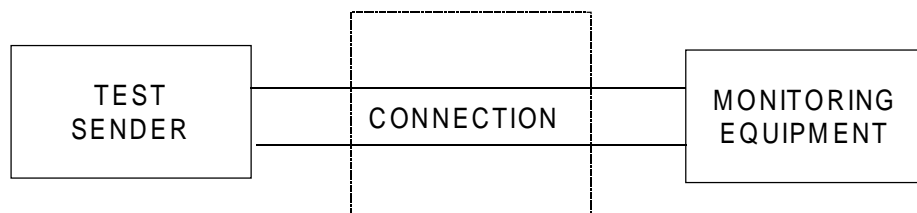

Figure A.4: Maximum instantaneous power

Connection state: Available.

Stimulus: The test sender, with an impedance of 600 Ω , is set to send a single cycle of a sine wave of frequency 1 020 Hz, at a level of +3 dBm, into the input of the leased line, with a duration of at least 50 ms between each cycle.

Monitor: The signal across a termination impedance of 600 Ω at the far end of the leased line.

Result: There shall be no clipping of the signal at the output of the leased line.

A.2.1.4 Random circuit noise

Requirement: Subclause 4.1.8.
 Purpose: To measure the random circuit noise of the leased line connection.
 Test configuration: Performed using a psophometer complying with CCITT Recommendation O.41 [1].
 With the far end interface of the leased line terminated with the reference impedance, the psophometer is connected to the near end interface. See figure A.5.

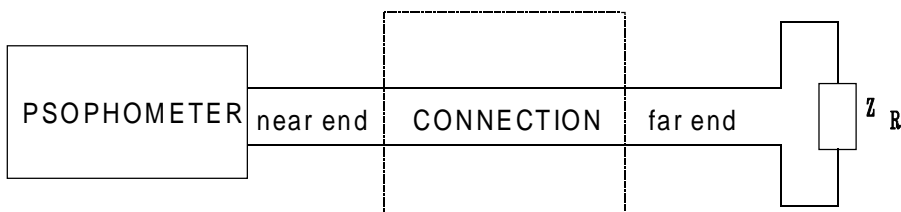

Figure A.5: Random circuit noise

Connection state: Available.
 Stimulus: None.
 Monitor: The psophometrically weighted noise signal across the 600 Ω termination at the near end interface of the leased line.

NOTE: The psophometer terminates the near end of the line with its own internal 600 Ω termination.

Result: The readings obtained shall be within the limits specified in subclause 4.1.8.

A.2.1.5 Stability

Requirement: Subclause 4.1.15.2.
 Purpose: To verify the stability of the leased line under open circuit and short circuit conditions.
 Test configuration: With the far end interface terminated in turn both open circuit and short circuit, a level meter (or similar equipment) with an input impedance of > 100 kΩ is connected to the near end interface. See figure A.6.

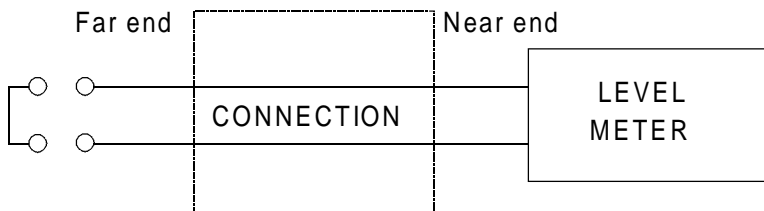

Figure A.6: Stability

Connection state: Available.
 Stimulus: None.
 Monitor: The frequency band 20 Hz to 4 000 Hz.

Result: Any signal level shall be > 22 dB below the level that would be received if a signal of -9 dBm at a frequency of 1 020 Hz were transmitted into the far end of the leased line.

A.2.2 Tests for interface presentation

A.2.2.1 Return loss

Requirement: Subclause 4.2.3

Purpose: To measure the return loss of the input impedance of the leased line with respect to the reference impedance Z_R .

Test configuration: The leased line interface is connected as shown in figure A.7.

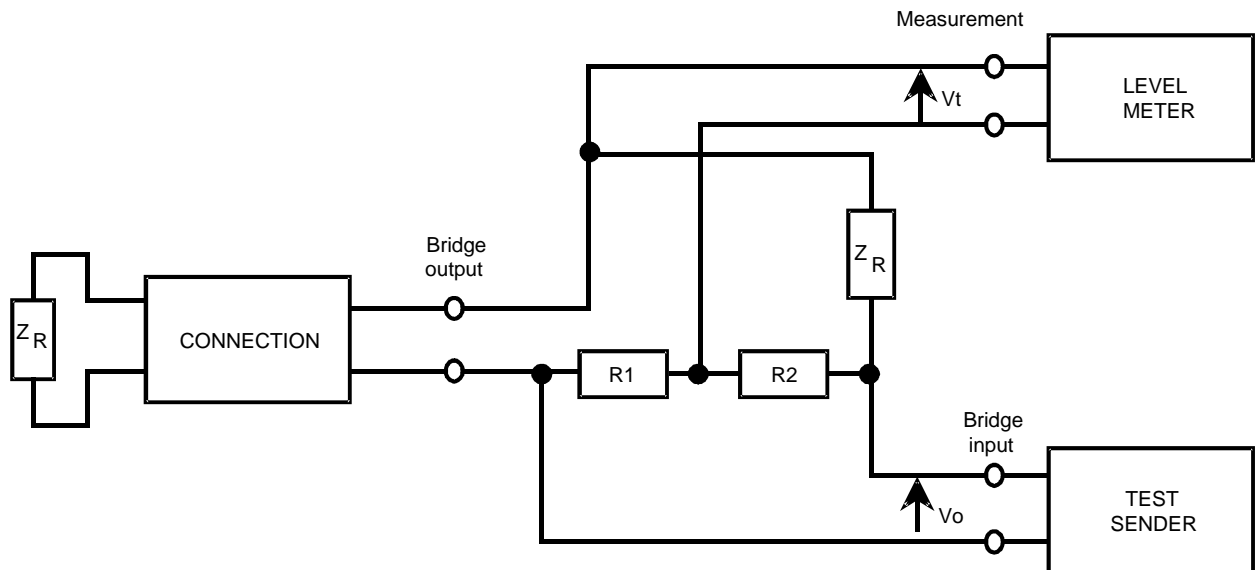

$R_1 = R_2$; between 100 Ω and 800 Ω , preferably 600 Ω , matched to better than 0,2 %
 Test sender output impedance < 10 Ω
 Level meter input impedance > 1 M Ω

Figure A.7: Return loss

Connection state: Available.

Stimulus: A sinusoidal signal with a constant voltage is applied to the input of the bridge at various frequencies between 300 Hz and 3 400 Hz. The constant voltage is that required to give a power level of -9 dBm at 1 020 Hz into a reference impedance connected to the output of the bridge. Each measurement frequency shall be spaced by not more than one third of an octave from the next frequency of measurement.

Monitor: The level of voltages V_t and V_o with the leased line input connected to the output of the bridge, as shown in figure A.7.

Result: Either the return loss $a(f)$ or the weighted return loss a_w shall meet the requirement of subclause 4.2.3 across the frequency range; where:

$$a(f) = 20 \log \left| \frac{V_o}{2V_t} \right| \text{ is the measured return loss at frequency } f,$$

$$a_w = 3,85 - 10 \log \left[\int_{300}^{3400} \frac{A(f)}{f} df \right] \text{dB}, \text{ and}$$

$$A(f) = 10^{-a(f)/10}$$

where V_o is the test signal level

and V_t is the level measured across the bridge.

Information on the application of the weighting function is given in Annex B.

A.2.2.2 Power feeding

Requirement: Subclause 4.2.4.

Purpose: To verify that the leased line is not designed for power feeding by measuring the output current from the leased line into an impedance of 300 Ω.

Test configuration: See figure A.8. The termination at the far end of the leased line is undefined.

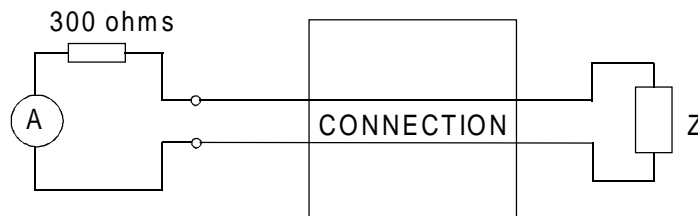

Figure A.8: Power feeding

Connection state: Available.

Stimulus: None.

Monitor: The current through a resistance of 300 Ω.

Result: The current through 300 Ω shall be less than 1 mA.

Annex B (informative): Weighted return loss measurements

B.1 Introduction

The use of a weighted return loss measurement is allowed within this ETS because a fixed return loss is difficult to meet in some situations. Such situations include long local ends to leased lines and short local ends to leased lines in tandem with loaded cable. The definition of a complex reference impedance solves the problem for long local ends but in the case of lines containing loaded cable the situation is worse. The problem results from the behaviour of the impedance of loaded cable near to the cut-off frequency and it is for this reason that the weighting function has been introduced into the requirement to give more weight to the lower frequencies.

B.2 Weighting function

Limitations are placed on the impedance of the leased line interface in order to control trans-hybrid loss in the terminal equipment. A weighting function which relates to trans-hybrid loss and which is relatively convenient to use is provided for the determination of echo loss in CCITT Recommendation G.122; this weighting function can also be used for the determination of the weighted return loss.

The weighted return loss a_w is derived from the integral of the power transfer characteristic, $A(f)$, weighted by a negative slope of 3 dB per octave, starting at 300 Hz and extending to 3 400 Hz as follows:

$$a_w = 3,85 - 10 \log \left[\int_{300}^{3400} \frac{A(f)}{f} df \right] \text{dB} \quad (1)$$

where

$$A(f) = 10^{-a(f)/10}$$

and

$a(f)$ is the measured return loss at frequency f expressed in dB.

B.2.1 Calculation (trapezoidal rule)

In order to calculate the weighted return loss, the weighting function can be approximated by choosing measurement frequencies that are equidistant on a log-frequency scale and using the trapezoidal rule, as described in Annex B of CCITT Recommendation G.122. Thus if equidistant measurement frequencies are chosen on a log-frequency scale and the measurement frequencies are spaced by no more than one third of an octave, then the weighted return loss a_w can be represented by:

$$a_w = -10 \log \left[\frac{1}{N} \left(\frac{A_0}{2} + A_1 + A_2 + A_3 + \dots + A_{N-1} + \frac{A_N}{2} \right) \right] \quad (2)$$

where

$N+1$ is the number of measurement frequencies

$$A_n = 10^{-a(f_n)/10}, \text{ for } n \text{ from } 0 \text{ to } N$$

and

$a(f_n)$ is the measured return loss at frequency f_n expressed in dB.

B.2.2 Calculation (tabulated data)

Where the loss/frequency data are only available at N+1 discrete frequencies, which are non-uniformly spaced on a log-frequency scale, an approximation to the formula for weighted return loss a_w can be given by:

$$a_w = 3,24 - 10\log \sum_{n=1}^N (A_n + A_{n-1})(\log f_n - \log f_{n-1}) \quad (3)$$

where N+1 is the number of measurement frequencies

$$A_n = 10^{-a(f_n)/10}, \text{ for } n \text{ from } 0 \text{ to } N$$

and $a(f_n)$ is the measured return loss at frequency f_n expressed in dB.

NOTE 1: The approximation involved is to assume that within the sub-band f_{n-1} to f_n , the power ratio is constant and has the value $A(f) = (A_n + A_{n-1})/2$.

NOTE 2: The constant 3,24 in the approximate formula arises from a combination of the constant 3,85 in the definition and other constants produced by the approximation.

The sum of product terms may be conveniently calculated as illustrated by the following example.

EXAMPLE: Weighted return loss = 3,24 - 10log(0,5050) = 6,21 dB

Table B.1: Example of calculation of weighted return loss

n	f (Hz)	log f _n	log f _n - log f _{n-1}	measured return loss	A _n	A _n + A _{n-1}	(3) x (6)
	(1)	(2)	(3)	(4)	(5)	(6)	(7)
0	300	2,477		5,00	0,316		
1	500	2,699	0,222	6,00	0,251	0,567	0,1259
2	800	2,903	0,204	8,00	0,158	0,410	0,0836
3	1 000	3,000	0,097	7,00	0,200	0,358	0,0347
4	1 500	3,176	0,176	6,00	0,251	0,451	0,0794
5	2 000	3,301	0,125	6,00	0,251	0,502	0,0628
6	2 500	3,398	0,097	6,00	0,251	0,502	0,0487
7	3 000	3,477	0,079	5,80	0,263	0,514	0,0407
8	3 400	3,531	0,054	5,60	0,275	0,538	0,0293
						Total	0,5050

Annex C (informative): Bibliography

- 1) 89/336/EEC: "Council Directive of 3 May 1989 on the approximation of the laws of Member states relating to electromagnetic compatibility".
- 2) 91/263/EEC: "Council Directive of 29 April 1991 on the approximation of the laws of Member States concerning telecommunications terminal equipment, including the mutual recognition of their conformity".
- 3) 92/44/EEC: "Council Directive of 5 June 1992 on the application of Open Network Provision to leased lines".
- 4) CCITT Recommendation G.114 (1988): "Mean one-way propagation time".
- 5) CCITT Recommendation G.122 (1988): "Influence of national systems on stability, talker echo, and listener echo in international connections".
- 6) CCITT Recommendation M.1040 (1988): "Characteristics of ordinary quality international leased circuits".
- 7) CCITT Recommendation V.2 (1988): "Power levels for data transmission over telephone lines".
- 8) prETS 300 450: "Business TeleCommunications (BTC); Ordinary and Special quality voice bandwidth 2-wire analogue leased lines (A2O and A2S); Terminal equipment interface".

History

Document history	
September 1994	Public Enquiry PE 70: 1994-09-05 to 1994-12-30
October 1995	Converted into Adobe Acrobat Portable Document Format (PDF)