



EUROPEAN
TELECOMMUNICATION
STANDARD

ETS 300 439

December 1996

Source: ETSI TC-BTC

Reference: DE/BTC-02048

ICS: 33.040.20

Key words: Digital, PBX, transmission characteristics

**Business TeleCommunications (BTC);
Transmission characteristics of digital
Private Branch eXchanges (PBXs)**

ETSI

European Telecommunications Standards Institute

ETSI Secretariat

Postal address: F-06921 Sophia Antipolis CEDEX - FRANCE

Office address: 650 Route des Lucioles - Sophia Antipolis - Valbonne - FRANCE

X.400: c=fr, a=atlas, p=etsi, s=secretariat - **Internet:** secretariat@etsi.fr

Tel.: +33 4 92 94 42 00 - Fax: +33 4 93 65 47 16

Copyright Notification: No part may be reproduced except as authorized by written permission. The copyright and the foregoing restriction extend to reproduction in all media.

© European Telecommunications Standards Institute 1996. All rights reserved.

Contents

Foreword	9
1 Scope	11
2 Normative references	11
3 Definitions and abbreviations	13
3.1 Definitions	13
3.1.1 Private Branch eXchange (PBX)	13
3.1.2 Test points, PBX input and output and half connections	13
3.1.2.1 Test points	13
3.1.2.2 PBX input and output	13
3.1.2.3 Half connections (analogue 2-wire or 4-wire, or digital)	13
3.1.3 Relative levels	14
3.1.3.1 Test points	14
3.1.3.2 Analogue interfaces	14
3.1.4 Transmission loss	14
3.1.4.1 Nominal transmission loss, analogue half connections	14
3.1.4.2 Switching Loss (SL)	14
3.1.4.3 Nominal transmission loss, full connections	14
3.1.5 Loss distortion with frequency	19
3.1.6 Parameters relevant for echo and stability	19
3.1.6.1 Terminal Balance Return Loss (TBRL)	19
3.1.6.2 Stability loss	19
3.1.6.3 Echo loss	19
3.1.7 Digital parameters	20
3.1.7.1 Bit integrity	20
3.1.8 Characteristics of interfaces	20
3.1.8.1 2-wire analogue interface	20
3.1.8.1.1 Interface L2	20
3.1.8.1.2 Interface M2	20
3.1.8.1.3 Interface K2	20
3.1.8.2 4-wire analogue interfaces	20
3.1.8.2.1 Interface M4	20
3.1.8.3 Digital interfaces	21
3.1.8.3.1 Interface LD	21
3.1.8.3.2 Interface MD	21
3.1.8.3.3 Interface KD	21
3.1.9 Voice frequency parameters of a connection between two interfaces of the same PBX	21
3.1.9.1 General	21
3.1.9.2 Overall transmission parameters	21
3.1.9.2.1 Transmission loss	21
3.1.9.2.2 Other overall parameters	21
3.1.9.3 Delay	21
3.1.9.3.1 Mean one way transmission time	21
3.1.9.3.2 Group delay	21
3.1.9.3.3 Group delay distortion	22
3.1.10 Loudness Ratings (LR)	22
3.1.10.1 Receiving Loudness Rating (RLR)	22
3.1.10.2 Sending Loudness Rating (SLR)	22
3.1.10.3 Talker sidetone, SideTone Masking Rating (STMR)	22
3.1.10.4 Listener SideTone Rating (LSTR)	22
3.1.11 System specific telephony terminal	22
3.1.12 Ear Reference Point (ERP)	22
3.1.13 Mouth Reference Point (MRP)	22
3.1.14 Acoustic Reference Level (ARL)	22

3.1.15	dBPa	22
3.1.16	dBPa(A)	22
3.2	Abbreviations.....	23
4	Compliance principles.....	23
5	Characteristics of analogue interfaces	24
5.1	PBX input impedance of interfaces K2, L2, M2 and M4.....	24
5.2	Transmission loss	25
5.2.1	Nominal transmission loss.....	25
5.2.2	Variation of gain with input level	25
5.2.3	Loss distortion with frequency	26
5.3	Group delay distortion	27
5.4	Noise	27
5.4.1	Weighted noise of interfaces without a feeding bridge.....	27
5.4.2	Weighted noise of interfaces with a feeding bridge.....	28
5.4.2.1	Output connection.....	28
5.4.2.2	Input connection.....	29
5.4.3	Unweighted noise of interfaces K2, L2, M2 and M4	29
5.4.4	Impulsive noise of interfaces K2, L2, M2 and M4.....	30
5.4.5	Single frequency noise of interfaces K2, L2, M2 and M4	30
5.5	Crosstalk	30
5.6	Total distortion including quantizing distortion.....	30
5.6.1	Values of total distortion of interfaces without a feeding bridge.....	30
5.6.2	Values of total distortion of interfaces with a feeding bridge.....	32
5.7	Discrimination against out-of-band signals applied to the K2, L2, M2 and M4 input interfaces.....	33
5.7.1	Input signals above 4,6 kHz.....	33
5.7.2	Signals below 300 Hz	33
5.8	Spurious out-of-band signals received at the K2, L2, M2 and M4 output interfaces.....	33
5.9	Echo and stability of interfaces K2, L2 and M2	33
5.9.1	Terminal Balance Return Loss (TBRL).....	33
5.9.2	Stability loss.....	34
6	Characteristics of digital interfaces.....	34
6.1	Coding law.....	34
6.2	Transmission loss	34
6.3	Error performance	35
6.4	Bit integrity.....	35
6.5	Bit sequence independence	35
7	Transmission characteristics of 3,1 kHz handset system specific telephony terminals	35
7.1	General.....	35
7.1.1	Applicability of transmission characteristics.....	35
7.1.2	Volume control.....	35
7.2	Speech performance characteristics for handset 3,1 kHz telephony.....	35
7.2.1	Sensitivity - frequency response.....	35
7.2.1.1	Sending	35
7.2.1.2	Receiving	36
7.2.2	Sending and Receiving Loudness Ratings (SLR and RLR)	36
7.2.3	Sidetone.....	37
7.2.3.1	Talker's sidetone	37
7.2.3.2	Listener's sidetone	37
7.2.4	Echo loss	37
7.2.5	Stability loss.....	37
7.2.6	Distortion.....	38
7.2.6.1	Sending.....	38
7.2.6.1.1	Method 1 (Pseudo random noise stimulus).....	38
7.2.6.1.2	Method 2 (Sinusoidal test signal)	38
7.2.6.2	Receiving	38
7.2.6.2.1	Method 1 (Pseudo random noise stimulus).....	38

		7.2.6.2.2	Method 2 (Sinusoidal test signal).....	38
		7.2.6.3	Sidetone distortion	40
	7.2.7		Variation of gain with input level	40
		7.2.7.1	Sending.....	40
		7.2.7.2	Receiving.....	41
	7.2.8		Out-of-band signals.....	42
		7.2.8.1	Discrimination against out-of-band input signals (sending)	42
		7.2.8.2	Spurious out-of-band signals (receiving)	42
	7.2.9		Noise	43
		7.2.9.1	Sending.....	43
		7.2.9.2	Receiving.....	43
		7.2.9.3	Level of sampling frequency (receiving)	43
8	Characteristics for connections between two interfaces			43
	8.1	General		43
	8.2	Transmission loss between interfaces.....		43
	8.3	Quantizing distortion units (qdu)		43
	8.4	Mean one-way transmission time		43
	8.5	Stability loss		43
		8.5.1	Stability loss of interfaces connected to a KD interface	43
		8.5.2	Stability loss of interfaces connected to M4 or MD interfaces.....	44
	Annex A (normative): Digital PBX transmission characteristic measurements.....			45
A.1	General.....			45
	A.1.1	Common measurement configurations.....		45
		A.1.1.1	Environmental conditions	45
		A.1.1.2	Operational conditions.....	45
	A.1.2	Digital signal processing		45
	A.1.3	Reference frequency.....		46
	A.1.4	Impedance		46
	A.1.5	Measurement points		46
	A.1.6	Test Instruments		46
	A.1.7	Test levels.....		46
	A.1.8	Disturbing effects		47
	A.1.9	Alternative test methods		47
A.2	Test point and access to the test point.....			47
	A.2.1	Basic principle.....		47
	A.2.2	Physical nature of test access		47
	A.2.3	Set-up of test connections		47
A.3	Auxiliary test equipment			48
	A.3.1	General		48
	A.3.2	dc power supply		48
	A.3.3	Transmission Decoupling Unit (TDU)		48
	A.3.4	External hybrid for return loss measurements		50
	A.3.5	Test Equipment Interface (TEI)		50
A.4	Specific measurements.....			51
	A.4.1	General procedure for measurement arrangements		51
	A.4.2	Analogue interfaces, half connection measurements.....		51
		A.4.2.1	Input connections	51
			A.4.2.1.1 Input transmission loss / input short-term variation of loss with time.....	51
			A.4.2.1.2 Input variation of gain with input level.....	52
			A.4.2.1.3 Input loss distortion with frequency.....	52
			A.4.2.1.4 Input total distortion including quantizing distortion	52
			A.4.2.1.5 Discrimination against out-of-band signals applied to the input interface	53
		A.4.2.2	Output connections	53
			A.4.2.2.1 Output transmission loss / output short-term variation of loss with time	53

	A.4.2.2.2	Output variation of gain with input level	53
	A.4.2.2.3	Output loss distortion with frequency	54
	A.4.2.2.4	Output total distortion including quantizing distortion	54
A.4.3	Analogue interfaces impedance measurements		54
	A.4.3.1	Return loss	54
	A.4.3.2	TBRL, stability	55
A.4.4	Analogue interfaces, crosstalk		55
	A.4.4.1	Input connections	56
	A.4.4.1.1	Far End Crosstalk (FEXT)	56
	A.4.4.1.2	Near End Crosstalk (NEXT)	56
	A.4.4.2	Output connections	57
	A.4.4.2.1	Far End Crosstalk (FEXT)	57
	A.4.4.2.2	Near End Crosstalk (NEXT)	57
A.4.5	Analogue interfaces, noise measurements		57
	A.4.5.1	Weighted noise measurements	57
	A.4.5.1.1	Input connections	58
	A.4.5.1.2	Output connections	58
A.5	Electro-acoustic measurements		59
	A.5.1	General measurement arrangement	59
	A.5.1.1	Electro-acoustic test equipment	59
	A.5.1.2	Accuracy of test equipment	59
	A.5.1.3	Ideal codec approach and specification	60
	A.5.1.3.1	Codec approach	60
	A.5.1.3.2	Codec specification	60
	A.5.1.4	Selective measurements	61
	A.5.1.5	Use of digital loss or gain pads	62
	A.5.2	Specific electro-acoustic measurements	62
	A.5.2.1	Sensitivity - frequency response	62
	A.5.2.1.1	Sending	62
	A.5.2.1.2	Receiving	62
	A.5.2.2	Loudness Ratings (LR)	63
	A.5.2.2.1	Sending Loudness Rating (SLR)	63
	A.5.2.2.2	Receiving Loudness Rating (RLR)	63
	A.5.2.3	Sidetone	63
	A.5.2.3.1	Talker's sidetone	63
	A.5.2.3.2	Listener's sidetone	63
	A.5.2.4	Echo loss	64
	A.5.2.5	Stability loss	64
	A.5.2.6	Distortion	65
	A.5.2.6.1	Sending	65
	A.5.2.6.1.1	Method 1	65
	A.5.2.6.1.2	Method 2	66
	A.5.2.6.2	Receiving	66
	A.5.2.6.2.1	Method 1	66
	A.5.2.6.2.2	Method 2	66
	A.5.2.6.3	Sidetone	66
	A.5.2.7	Variation of gain with input level	67
	A.5.2.7.1	Sending	67
	A.5.2.7.2	Receiving	67
	A.5.2.8	Out-of-band signals	67
	A.5.2.8.1	Discrimination against out-of-band input signal	67
	A.5.2.8.2	Spurious out-of-band signals	67
	A.5.2.9	Noise	67
	A.5.2.9.1	Sending	67
	A.5.2.9.2	Receiving	68
	A.5.2.9.3	Level of sampling frequency (receiving)	68
Annex B (informative):	General considerations for the choice of test instrumentation		78
B.1	Overall measuring accuracy		78
B.2	Measurement capabilities		78

B.3	Instrument requirements	79
B.4	Measuring accuracy	80
Annex C (informative):	Relationship between the units dBm, dBr and dBm0	84
C.1	General.....	84
C.2	The unit "dB"	84
C.3	The unit "dBm"	84
C.4	The unit "dBr"	85
C.5	The unit "dBm0"	86
C.6	The letter "p" in "dBmp" and "dBm0p"	87
C.7	The relationship between dBm, dBr and dBm0.....	87
C.8	Correction factors.....	87
Annex D (informative):	The concept of "relative levels"	90
D.1	General principles	90
D.2	The speech signal and the dynamic range of the voice channel	90
D.3	Relative level designations for a digital path	94
D.4	Relative levels in equipment design, specification and testing.....	95
D.4.1	Analogue equipment.....	95
D.4.2	Codecs and digital pads.....	95
D.4.3	Digital exchanges.....	95
D.5	Relative levels in transmission planning and maintenance	97
Annex E (informative):	Impedances and relative levels used up to now by the various European administrations	100
Annex F (informative):	Bibliography.....	105
History.....		106

Blank page

Foreword

This European Telecommunication Standard (ETS) has been produced by the Business Telecommunications (BTC) Technical Committee of the European Telecommunications Standards Institute (ETSI).

This ETS is intended to be used as a specification for the design of Private Branch eXchanges (PBXs) and for the harmonization of PBX transmission parameters throughout Europe. It is based on four Interim ETSs (I-ETSs):

- I-ETS 300 003 (1991): "Business Telecommunications (BT); Transmission characteristics of digital Private Automatic Branch Exchanges (PABXs)";
- I-ETS 300 004 (1991): "Business Telecommunications (BT); Transmission characteristics at 2-wire analogue interfaces of a digital Private Automatic Branch Exchange (PABX)";
- I-ETS 300 005 (1991): "Business Telecommunications (BT); Transmission characteristics at 4-wire analogue interfaces of a digital Private Automatic Branch Exchange (PABX)"; and
- I-ETS 300 006 (1991): "Business Telecommunications (BT); Transmission characteristics at digital interfaces of a digital Private Automatic Branch Exchange (PABX)".

Transposition dates	
Date of adoption	22 November 1996
Date of latest announcement of this ETS (doa):	31 March 1997
Date of latest publication of new National Standard or endorsement of this ETS (dop/e):	30 September 1997
Date of withdrawal of any conflicting National Standard (dow):	30 September 1997

Blank page

1 Scope

This European Telecommunication Standard (ETS) specifies the transmission requirements for digital Private Branch eXchanges (PBXs) (through-connecting telecommunications equipment) that:

- are not part of the public network;
- carry 3,1 kHz telephony between analogue interfaces, digital interfaces carrying 64 kbit/s A-law encoded signals and the acoustic interfaces of handset telephony terminals that are designed to be used together with the PBX for connections involving digital access to the public switched network;
- are capable of providing, for the purposes of testing, a test point that offers a 64 kbit/s - signal with bit integrity to the digital transmission path (this test point need not be provided in production versions of a PBX).

NOTE: When dealing with voice bandwidth data transmission, special consideration may have to be given to certain parameters e.g. group delay distortion, error performance, bit integrity, bit sequence independence (the list is not exhaustive).

This ETS applies to PBXs that carry 3,1 kHz voice telephony, irrespective of whether they carry other services in addition.

This ETS does not apply to:

- cordless interfaces or digital interfaces carrying signals coded using other coding laws;
- the transmission of services other than 3,1 kHz voice telephony; and
- handsfree and loudspeaking telephony terminals.

2 Normative references

This ETS incorporates by dated and undated reference, provisions from other publications. These normative references are cited at the appropriate places in the text and the publications are listed hereafter. For dated references, subsequent amendments to or revisions of any of these publications apply to this ETS only when incorporated in it by amendment or revision. For undated references the latest edition of the publication referred to applies.

- [1] ETR 004 (1990): "Business Telecommunications (BT); Overall transmission plan aspects of a private branch network for voice connections with access to the public network".
- [2] ETS 300 283 (1994): "Business Telecommunications (BTC); Planning of loudness rating and echo values for private networks digitally connected to the public network".
- [3] ITU-T Recommendation G.101 (1993): "The transmission plan".
- [4] CCITT Recommendation G.103 (1988): "Hypothetical reference connections".
- [5] ITU-T Recommendation G.121 (1993): "Loudness Ratings (LRs) of national systems".
- [6] ITU-T Recommendation G.122 (1993): "Influence of national systems on stability talker echo in international connections".
- [7] CCITT Recommendation G.123 (1988): "Circuit noise in national networks".
- [8] CCITT Recommendation G.171 (1988): "Transmission plan aspects of privately operated networks".

- [9] CCITT Recommendation G.223 (1988): "Assumptions for the calculation of noise on hypothetical reference circuits for telephony".
- [10] CCITT Recommendation G.703 (1991): "Physical/electrical characteristics of hierarchical digital interfaces".
- [11] CCITT Recommendation G.711 (1988): "Pulse code modulation (PCM) of voice frequencies".
- [12] CCITT Recommendation G.712 (1992): "Transmission performance characteristics of pulse code modulation".
- [13] CCITT Recommendation I.430 (1988): "Basic user-network interface - Layer 1 specification".
- [14] CCITT Recommendation O.9 (1988): "Measuring arrangements to access the degree of unbalance about earth".
- [15] ITU-T Recommendation O.41 (1994), Revision 1: "Psophometer for use on telephone-type circuits".
- [16] CCITT Recommendation O.131 (1988): "Quantizing distortion measuring equipment using a pseudo-random noise test signal".
- [17] CCITT Recommendation O.132 (1988): "Quantizing distortion measuring equipment using a sinusoidal test signal".
- [18] ITU-T Recommendation O.133 (1993): "Equipment for measuring the performance of PCM encoders and decoders".
- [19] ITU-T Recommendation P.51 (1993): "Artificial mouths".
- [20] CCITT Recommendation P.53 (1988): "Psophometers (apparatus for the objective measurement of circuit noise)".
- [21] ITU-T Recommendation P.57 (1993): "Artificial ears".
- [22] CCITT Recommendation P.64 (1988): "Determination of sensitivity/frequency characteristics of local telephone systems to permit calculation of their loudness ratings".
- [23] ITU-T Recommendation P.64 (1993): "Determination of sensitivity/frequency characteristics of local telephone systems".
- [24] ITU-T Recommendation P.65 (1993): "Objective instrumentation for the determination of loudness ratings".
- [25] ITU-T Recommendation P.79 (1993): "Calculation of loudness ratings for telephone sets".
- [26] CCITT Recommendation Q.45 bis (1988): "Transmission characteristics of an analogue international exchange".
- [27] ITU-T Recommendation Q.551 (1994): "Transmission characteristics of digital exchanges".
- [28] ITU-T Recommendation Q.552 (1994): "Transmission characteristics at 2-wire analogue interfaces of a digital exchanges".
- [29] IEC 225 (1966): "Octave, half octave and third-octave band filters intended for the analysis of sound and vibrations".

- [30] IEC 651 (1979): "Sound level meters".
- [31] ISO 3 (1973): "Preferred numbers - series of preferred numbers".
- [32] ISO/DIS 9614-1 (1993): "Acoustics determination of sound power levels of noise sources using sound intensity - Measurement at discrete points".
- [33] CCITT Fascicle VI.5 (Blue Book, 1988): "Digital local, transit, combined and international exchanges in integrated digital networks and mixed analogue-digital networks".

NOTE: This ETS also contains a number of informative references which have been included to indicate the sources from which various material has been derived, hence they do not have an associated normative reference number. Details of these publications are given in annex F. In some cases the same publication may have been referenced in both a normative and an informative manner.

3 Definitions and abbreviations

3.1 Definitions

For the purposes of this ETS, the following definitions apply.

3.1.1 Private Branch eXchange (PBX)

A through connecting telecommunications equipment capable of establishing circuit switched connections between different interfaces under the control of the end user and intended for use outside the public switched network.

3.1.2 Test points, PBX input and output and half connections

3.1.2.1 Test points

The test points shown in figure 3 are defined for specification purposes. They may not physically exist in a PBX but may be accessed at the Access Point (AP) via the digital switching network. In this case, a part or all of the switching network will be included in the path from the PBX interface to the points of access to the test points.

NOTE: For more information see annex A, clause A.2.

3.1.2.2 PBX input and output

The PBX input and output for a connection through a digital PBX are located at the interfaces identified in clause 1 and shown in figures 1, 2 and 3.

3.1.2.3 Half connections (analogue 2-wire or 4-wire, or digital)

Input connection: a unidirectional path from an input of a digital PBX to an output test point.

Output connection: a unidirectional path from an input test point to an output of a digital PBX.

Half connection: a bi-directional path comprised of an input connection and an output connection, both having the same interface.

3.1.3 Relative levels

3.1.3.1 Test points

The input and output test points are defined as 0 dBr points for the equipment under test.

NOTE: See annex D for a discussion of relative levels.

3.1.3.2 Analogue interfaces

The nominal relative level at the PBX input point is designated L_i .

The nominal relative level at the PBX output point is designated L_o .

3.1.4 Transmission loss

3.1.4.1 Nominal transmission loss, analogue half connections

A connection through the PBX (see figure 3) is established by connecting in both directions an input located at one interface to an output located at another interface.

The nominal transmission loss between the input at an analogue interface and the output test point is defined as:

$$NL_i = L_i \quad [\text{dB}]$$

The nominal transmission loss between the input test point and the output of an analogue interface is defined as:

$$NL_o = -L_o \quad [\text{dB}]$$

NOTE: It is assumed that L_i and L_o are achieved by operating on the analogue signal, only.

3.1.4.2 Switching Loss (SL)

Where there are two digital points within the PBX between which bit integrity is not preserved, there is a Switching Loss (SL) between them.

NOTE 1: Devices which cause bit integrity to be lost include digital pads, code converters and echo control devices.

NOTE 2: SL may be associated with a digital interface, with additional loss adjustment of an analogue interface, or with additional loss adjustment in the switching network. As an example, switching loss may be constantly assigned to an interface, e.g. to achieve an L_i of +3 dBr by using an ideal codec followed by a 3 dB digital loss. The requirements assume, however, that all kinds of switching loss can be switched off (see also clause 4).

NOTE 3: By the use of SL the relative levels can remain unchanged.

3.1.4.3 Nominal transmission loss, full connections

The nominal transmission loss for a connection through a PBX is equal to the difference of the relative levels at the input and the output, plus switching loss in the connection. Therefore the nominal transmission loss between analogue interfaces is defined as:

$$NL = L_i - L_o + SL \quad [\text{dB}]$$

The nominal transmission loss between the input of an analogue interface and the output of a digital interface is defined as:

$$NL = L_i + SL \quad [\text{dB}]$$

The nominal transmission loss between the input of a digital interface and the output of an analogue interface is defined as:

$$NL = -L_o + SL \quad [\text{dB}]$$

The nominal transmission loss between digital interfaces is defined as:

$$NL = SL \quad [\text{dB}]$$

NOTE: SL represents the value of any Switching Loss implemented in the PBX.

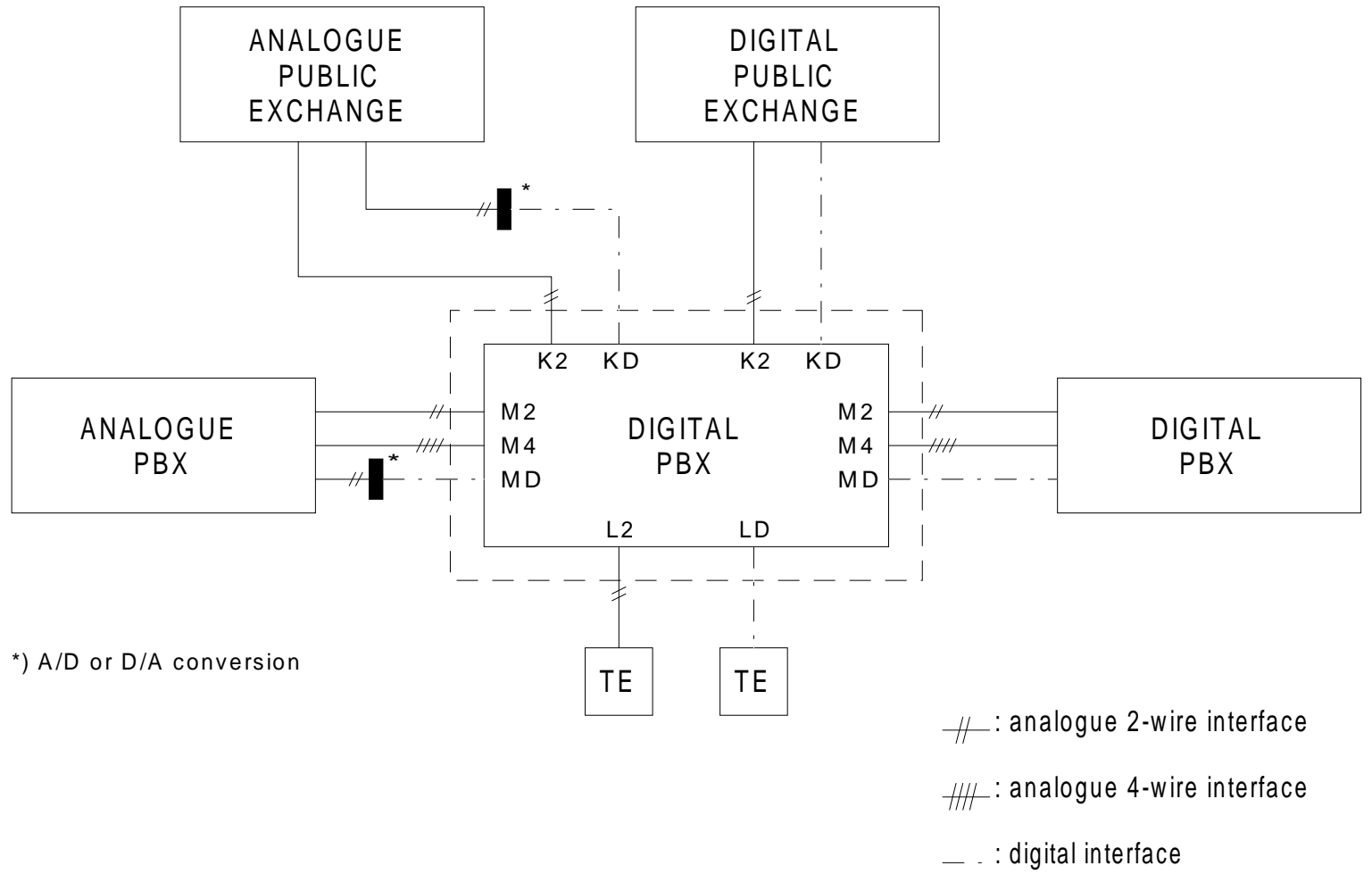

*) A/D or D/A conversion

Figure 1: Interfaces of digital PBX's in network interconnections

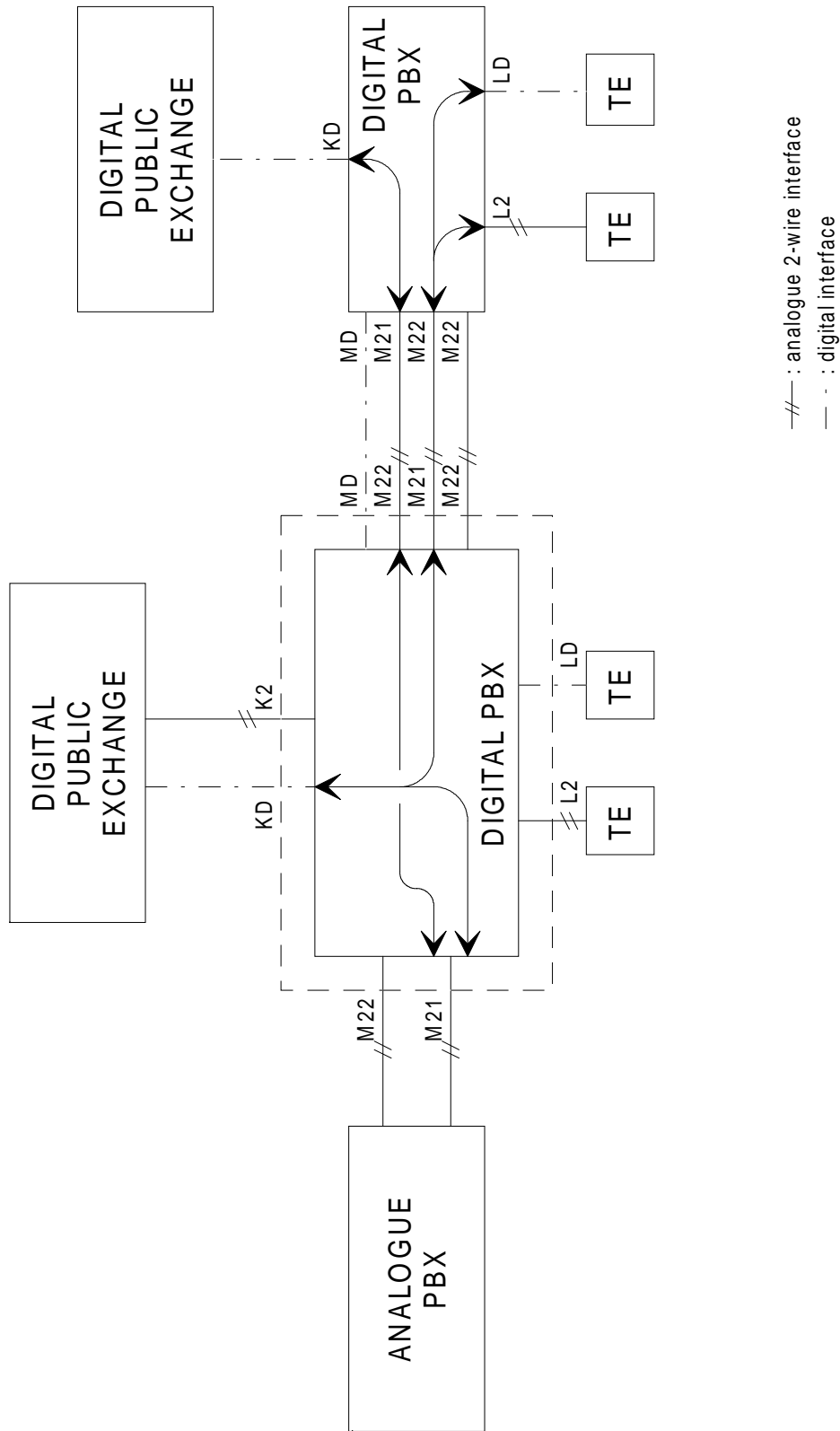

Figure 2: Detailed illustration for access to Public Switched Telephone Network (PSTN) involving M2 interfaces

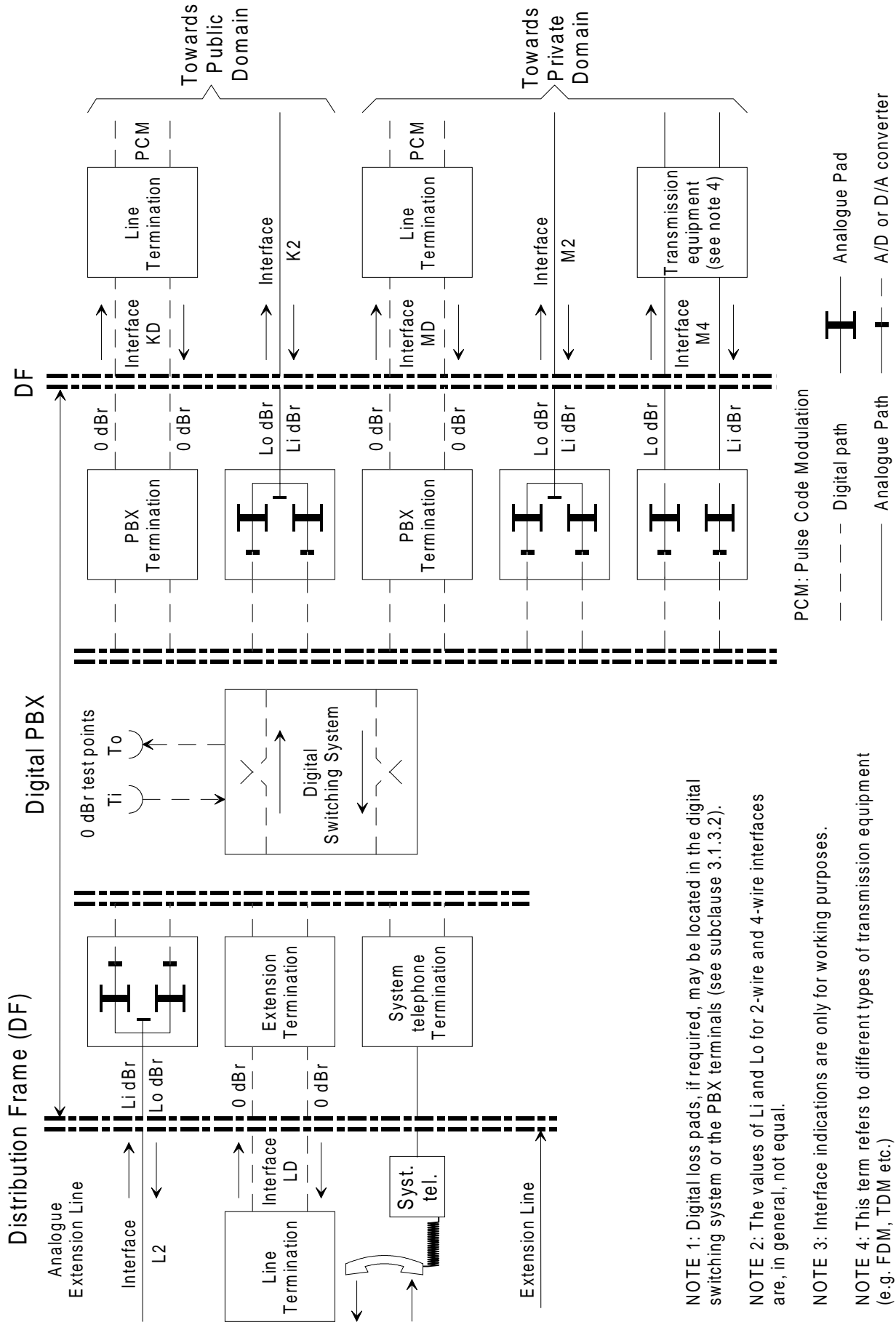

Figure 3: Interfaces, transmission levels and test points at a digital PBX

3.1.5 Loss distortion with frequency

The loss distortion with frequency is the logarithmic ratio of output voltage at the reference frequency (nominally 1 020 Hz), $U(1\ 020\ \text{Hz})$, divided by its value at frequency f , $U(f)$:

$$LD = 20 \log \frac{U(1020\text{Hz})}{U(f)} \quad [\text{dB}]$$

See subclause 1.2.5 of ITU-T Recommendation Q.551 [27] and supplement No.1 in Fascicle VI.5 [33] of the CCITT Blue Book.

3.1.6 Parameters relevant for echo and stability

Terminal Balance Return Loss (TBRL) is introduced in order to characterize the PBX performance with respect to echo. The TBRL of an equipment port is measured in the talking state as in an established connection through a digital PBX. For measurement of TBRL, see annex A.

The parameter "stability loss" as defined in ITU-T Recommendation G.122 [6], applies to the worst terminating conditions encountered at a 2-wire interface in normal operation.

3.1.6.1 Terminal Balance Return Loss (TBRL)

The term TBRL is used to characterize an impedance balancing property of the 2-wire analogue equipment port.

The expression for TBRL is:

$$TBRL = 20 \log \left| \frac{Z_a + Z_b}{2 \cdot Z_a} \cdot \frac{Z_t + Z_b}{Z_t - Z_b} \right| \quad [\text{dB}]$$

where:

- Z_a : PBX input impedance of a 2-wire equipment port;
- Z_b : impedance of the balance network presented at a 2-wire equipment port;
- Z_t : impedance of the balance test network.

NOTE: It could be advantageous to choose $Z_a = Z_b$ in order to optimize TBRL. In this case the expression reduces to:

$$TBRL = 20 \log \left| \frac{Z_t + Z_b}{Z_t - Z_b} \right| \quad [\text{dB}]$$

3.1.6.2 Stability loss

The stability loss is defined as the loss between the PBX test points T_i and T_o of a half connection (see also annex A).

3.1.6.3 Echo loss

The echo loss is the semi-loop loss averaged with $1/f$ power weighting over the voice frequency band, as defined in clause 4 of ITU-T Recommendation G.122 [6].

3.1.7 Digital parameters

3.1.7.1 Bit integrity

Bit integrity is the property of a digital half connection in which the binary values and the sequence of the bits in an octet and of the octets at the input of the half connection are reproduced exactly at the output.

NOTE: Digital processing devices are disabled to provide bit integrity when needed.

3.1.8 Characteristics of interfaces

The interfaces taken into account are those of figure 3. For voice frequency interfaces (L2, M2, K2 and M4) the electrical parameters refer to the appropriate Interface Measurement Points (IMP). For further details, see subclause A.1.5. For limitations on the cable length between Distribution Frame (DF) and the actual digital PBX interface, see CCITT Recommendation G.703 [10].

3.1.8.1 2-wire analogue interface

3.1.8.1.1 Interface L2

The interface L2 provides for the connection of 2-wire analogue extension lines and will carry signals such as speech, voice-band analogue data and multi-frequency push-button signals, etc. In addition, the interface L2 provides for ordinary functions such as direct current (dc) feeding, dc signalling, ringing, etc.

NOTE 1: Since the interface L2 terminates the extension line, the impedance and unbalance about earth should be controlled.

NOTE 2: The interface L2 is a 2-wire analogue extension interface used to connect terminals which are also intended to be connected directly to the PSTN.

3.1.8.1.2 Interface M2

The interface M2 provides for connection to 2-wire analogue inter-PBX circuits e.g. via leased lines. The interface M2 is subdivided into the interfaces "M21" and "M22".

The interface M21 provides the termination of connections to/from the PSTN wired to all types of K interfaces (also via digital (Interface KD, see subclause 3.1.8.3.3) subscriber line access) with the PBX concerned acting as a transit switch (see figure 2).

The interface M22 provides the termination of connections other than those covered by M21. A typical example is the interconnection of an L2 interface with an M22 interface in a PBX for routings through existing 2-wire analogue circuits to other PBXs (see figure 2).

3.1.8.1.3 Interface K2

The interface K2 provides for the connection of 2-wire analogue subscriber lines between PBX and Public Exchange.

NOTE: Since the interface K2 ordinarily terminates the line to the public exchange, the impedance and unbalance about earth should be controlled.

3.1.8.2 4-wire analogue interfaces

3.1.8.2.1 Interface M4

The interface M4 provides for connection to 4-wire analogue inter-PBX circuits.

With the PBX acting as a transit switch (see figures 1 and 3), this interface can be part of an incoming or outgoing connection to the public network.

NOTE: The performance of different transmission media used in conjunction with 4-wire analogue circuits between PBXs is not addressed in this ETS.

3.1.8.3 Digital interfaces

3.1.8.3.1 Interface LD

The interface LD is a digital extension interface used to connect terminals which are also intended to be connected directly to digital interfaces of the public switched network.

3.1.8.3.2 Interface MD

The interface MD provides for connection to a digital inter-PBX circuit.

3.1.8.3.3 Interface KD

The interface KD provides for the connection of a digital access to the public switched network.

3.1.9 Voice frequency parameters of a connection between two interfaces of the same PBX

3.1.9.1 General

This subclause provides guidance on obtaining the overall characteristics for connections between two interfaces of the same PBX.

NOTE: For an overall connection involving one or more digital interfaces, the results quoted assume that an ideal send and receive side (see CCITT Recommendation G.712 [12]) is connected to the digital inputs and outputs, respectively.

The transmission parameters relating to the input connection from a PBX interface to a PBX output test point will be referred to as input parameters. Transmission parameters relating to the output connection from a PBX input test point to a PBX interface will be referred to as output parameters. For additional information about the measurement configurations, see annex A.

3.1.9.2 Overall transmission parameters

3.1.9.2.1 Transmission loss

The transmission loss in each direction through the PBX is equal to the algebraic sum of the input transmission loss, the output transmission loss, and the Switching Loss (SL) in each direction between the two interfaces.

3.1.9.2.2 Other overall parameters

The overall characteristic for the following parameters can be obtained as given in subclause 3.1.9.2.1:

- loss distortion with frequency;
- variation of gain with input level.

3.1.9.3 Delay

3.1.9.3.1 Mean one way transmission time

The mean one way transmission time is the algebraic sum of the one-way transmission times in both directions of transmission between the two interfaces (of the PBX) divided by two.

NOTE: The one-way transmission time through a PBX may vary mainly dependent on the PBX architecture, the types of connections involved and the traffic load.

3.1.9.3.2 Group delay

The time of propagation between two points of a certain element (for example the crest) of the envelope of a wave. For a given frequency it is equal to the first derivative of the phase shift measured in radians, between these points, with reference to the angular frequency measured in radians per second.

3.1.9.3.3 Group delay distortion

The difference between group delay at a given frequency and minimum group delay, in the frequency band of interest.

3.1.10 Loudness Ratings (LR)

Within the context of ITU-T, a loudness rating is an objective measure of the loudness loss, i.e., a weighted, electro-acoustic loss between certain interfaces in the telephone network.

3.1.10.1 Receiving Loudness Rating (RLR)

The loudness loss between an electric interface and the Ear Reference Point (ERP).

3.1.10.2 Sending Loudness Rating (SLR)

The loudness loss between the Mouth Reference Point (MRP) and an electric interface.

3.1.10.3 Talker sidetone, SideTone Masking Rating (STMR)

The loudness loss between the Mouth Reference Point (MRP) and the Ear Reference Point (ERP) via the sidetone path.

3.1.10.4 Listener SideTone Rating (LSTR)

The loudness loss between a diffuse pink sound field representing the room noise source and the Ear Reference Point (ERP) via the electrical sidetone path.

3.1.11 System specific telephony terminal

A telephony terminal used for a specific PBX family for use in a digital environment. It is considered an integral part of the PBX in the sense that the characteristics of the path between the PBX itself and the telephony terminal is not subject to standardization. The system specific telephony terminal is not intended for direct connection to a public network.

3.1.12 Ear Reference Point (ERP)

A point located at the entrance to the ear canal of the listener's ear as described in figure A-1 of ITU-T Recommendation P.64 [23].

3.1.13 Mouth Reference Point (MRP)

A point 25 mm in front of and on the axis of the lip position of a typical human mouth (or artificial mouth) (see figure A-1 of ITU-T Recommendation P.64 [23]).

3.1.14 Acoustic Reference Level (ARL)

The acoustic level which gives -10 dBm₀ at the digital output test point.

3.1.15 dBPa

Sound pressure level relative to 1 Pa (no weighting).

3.1.16 dBPa(A)

Sound level relative to 1 Pa measured using the A-weighting defined in IEC 651 [30].

3.2 Abbreviations

For the purposes of this ETS, the following abbreviations apply:

ac	alternating current
AP	Access Point
APC	Access Point Connection
ARL	Acoustic Reference Level
dc	direct current
DF	Distribution Frame
DRS	Digital Reference Sequence
DTS	Digital Test Sequence
emf	electro motoric force
ERP	Ear Reference Point
FDM	Frequency Division Multiplex
FEXT	Far End Crosstalk
IMP	Interface Measurement Point
ISDN	Integrated Services Digital Network
IUT	Interface Under Test
LCL	Longitudinal Conversion Loss
LCTL	Longitudinal Conversion Transfer Loss
LD	Loss Distortion
LR	Loudness Rating
LRGP	Loudness Rating Guard ring Position
LSTR	Listener SideTone Rating
MNRU	Modulated Noise Reference Unit
MRP	Mouth Reference Point
NEXT	Near End Crosstalk
NL	Nominal (Transmission) Loss
NS	Not Specified
PBN	Private Branch Network
PBX	Private Branch eXchange
PCM	Pulse Code Modulation
PSTN	Public Switched Telephone Network
qdu	quantizing distortion unit
RLH	Return Loss Hybrid
RLR	Receiving Loudness Rating
RLR _{nom}	declared nominal RLR value
rms	root mean square
SL	Switching Loss
SLR	Sending Loudness Rating
SLR _{nom}	declared nominal SLR value
STMR	SideTone Masking Rating
TBRL	Terminal Balance Return Loss
TCLw	weighted Terminal Coupling Loss
TDU	Transmission Decoupling Unit
TEI	Test Equipment Interface
TRP	Transmission Reference Point
LSTR _{corr}	corrected LSTR value
LSTR _{meas}	measured LSTR value
RLR _{meas}	measured RLR value
SLR _{meas}	measured SLR value
STMR _{corr}	corrected STMR value
STMR _{meas}	measured STMR value

4 Compliance principles

All digital signal processing devices, which affect bit integrity of the 64 kbit/s speech-path within a digital PBX, e.g. digital loss or gain, digital echo control devices etc., shall be rendered inoperative, when measuring the transmission parameters of this ETS. However, if the Nominal Transmission Loss (NL) is implemented by a digital loss or gain, the parameters "Nominal value" and "Tolerance" of the relative levels for input and output connections shall be measured with digital loss or gain switched operative.

NOTE: In some digital PBXs such a digital loss or gain might be realized in a way, that it is not possible to switch this digital signal processing inoperative during measurement. However, several transmission parameters like quantizing distortion, variation of gain with input level etc., will be influenced additionally by digital signal processing. This means, the existing limits in this ETS - derived only for the process of encoding/decoding - may not be met.

5 Characteristics of analogue interfaces

For measuring 2-wire analogue interface conditions, refer also to annex A.

NOTE: Annex E provides the transmission planning people the information about values used up to now with respect to impedances and levels.

5.1 PBX input impedance of interfaces K2, L2, M2 and M4

The nominal value of the PBX impedance for 2-wire interfaces shall be:

$$Z_a = 270 \Omega + (750 \Omega \parallel 150 \text{ nF})$$

NOTE: The choice of this nominal value of the complex PBX impedance is providing a termination of:

- unloaded analogue subscriber line of a public exchange with reference to the interface K2;
- unloaded analogue lines between PBXs with reference to the interfaces M21 and M22 to ensure that the public network and every PBX will have adequate values of stability margin and echo.

The choice of this nominal value for the complex PBX impedance also ensures an adequate sidetone performance for telephony terminals connected via analogue lines to the L2 interface, particularly those operated on short lines. This impedance will also be suitable for extension lines fitted with voice band modems.

The nominal value of the PBX impedance for M4 interfaces shall be:

$$Z_a = 600 \Omega$$

The return loss of the impedance presented by K2, L2, M2 and M4 interfaces against the nominal value for the PBX impedance shall comply with the limits given in figure 4.

Compliance shall be checked by the method described in subclause A.4.3.1.

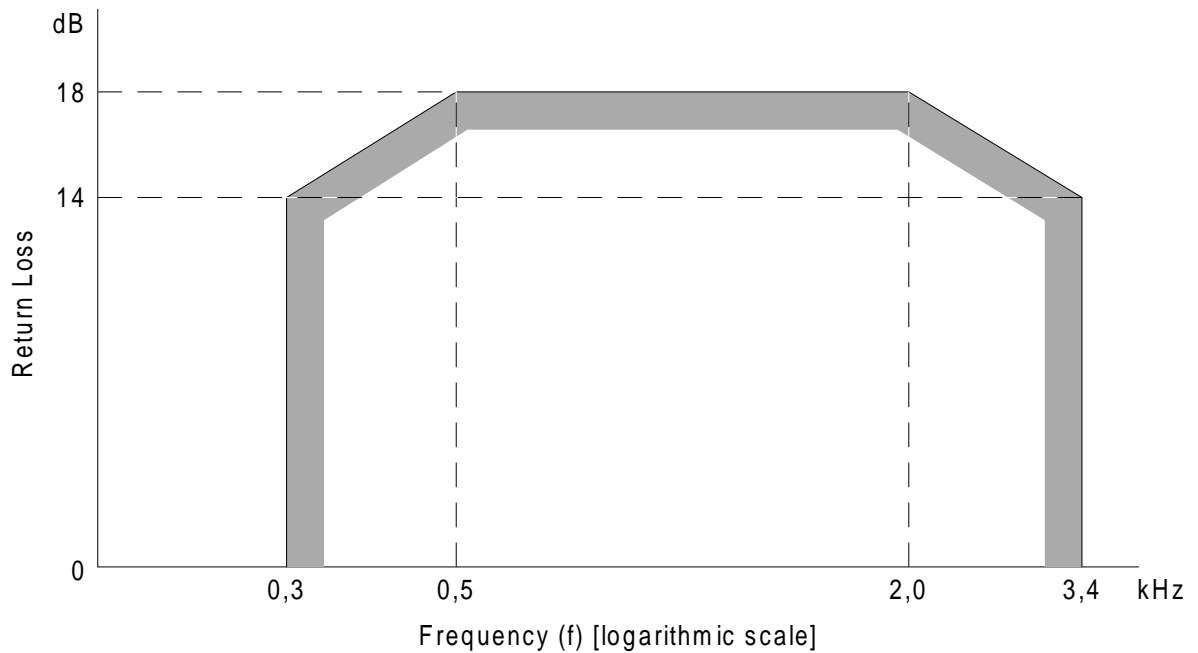

Figure 4: Minimum value of return loss against the nominal PBX impedance

5.2 Transmission loss

5.2.1 Nominal transmission loss

The nominal input and output relative levels shall have a value stated by the supplier.

The difference between the measured value of the transmission loss, between the interface and the test point, and the nominal value of transmission loss (NL_i and NL_o) calculated from the stated value of relative level, shall lie within the following ranges:

- input loss: -0,35 dB to +0,35 dB;
- output loss: -0,35 dB to +0,35 dB.

NOTE: These differences may arise, for example, from design tolerances and adjustment increments.

Compliance shall be checked by the methods described in subclauses A.4.2.1.1 and/or A.4.2.2.1.

5.2.2 Variation of gain with input level

With a sine-wave test signal at the reference frequency 1 020 Hz and at a level between -55 dBm₀ and +3 dBm₀, applied to the 2-wire or 4-wire analogue interface of any input connection, or with a digitally simulated sine-wave signal of the same characteristic applied to the PBX input test point T_i of any output connection, the gain variation of that connection, relative to the gain at an input level of -10 dBm₀, shall lie within the limits given in figure 5.

Compliance shall be checked by the methods described in subclauses A.4.2.1.2 and/or A.4.2.2.2.

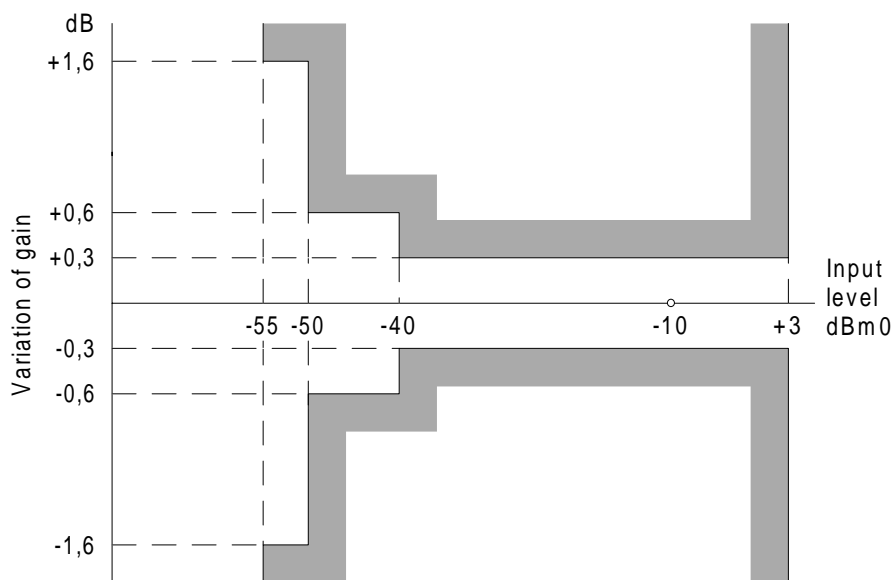

Figure 5: Variation of gain with input level

5.2.3 Loss distortion with frequency

The loss distortion with frequency of any input or output connection according to subclause 3.1.5 shall lie within the limits shown in the mask of figures 6 and 7, respectively. The preferred input level is -10 dBm0.

Compliance shall be checked by the methods described in subclauses A.4.2.1.3 and/or A.4.2.2.3.

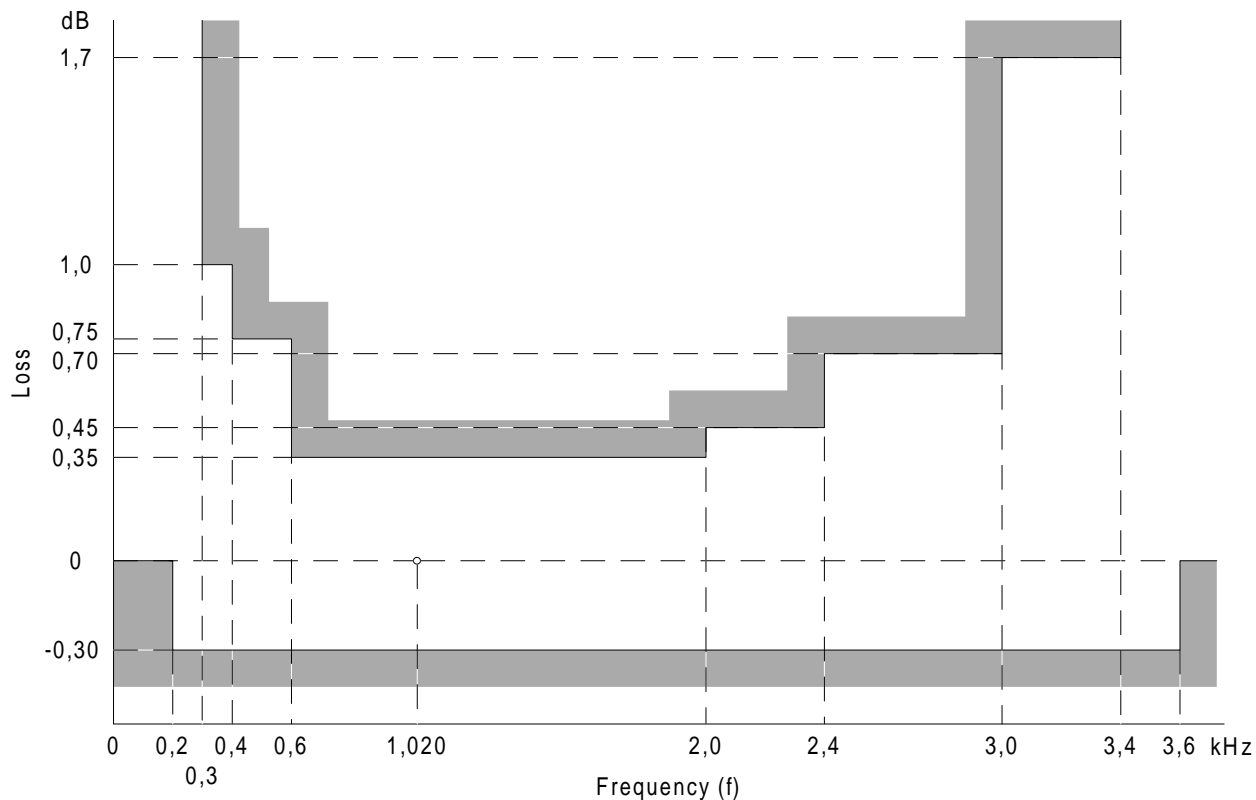

Figure 6: Loss distortion with frequency - input connection

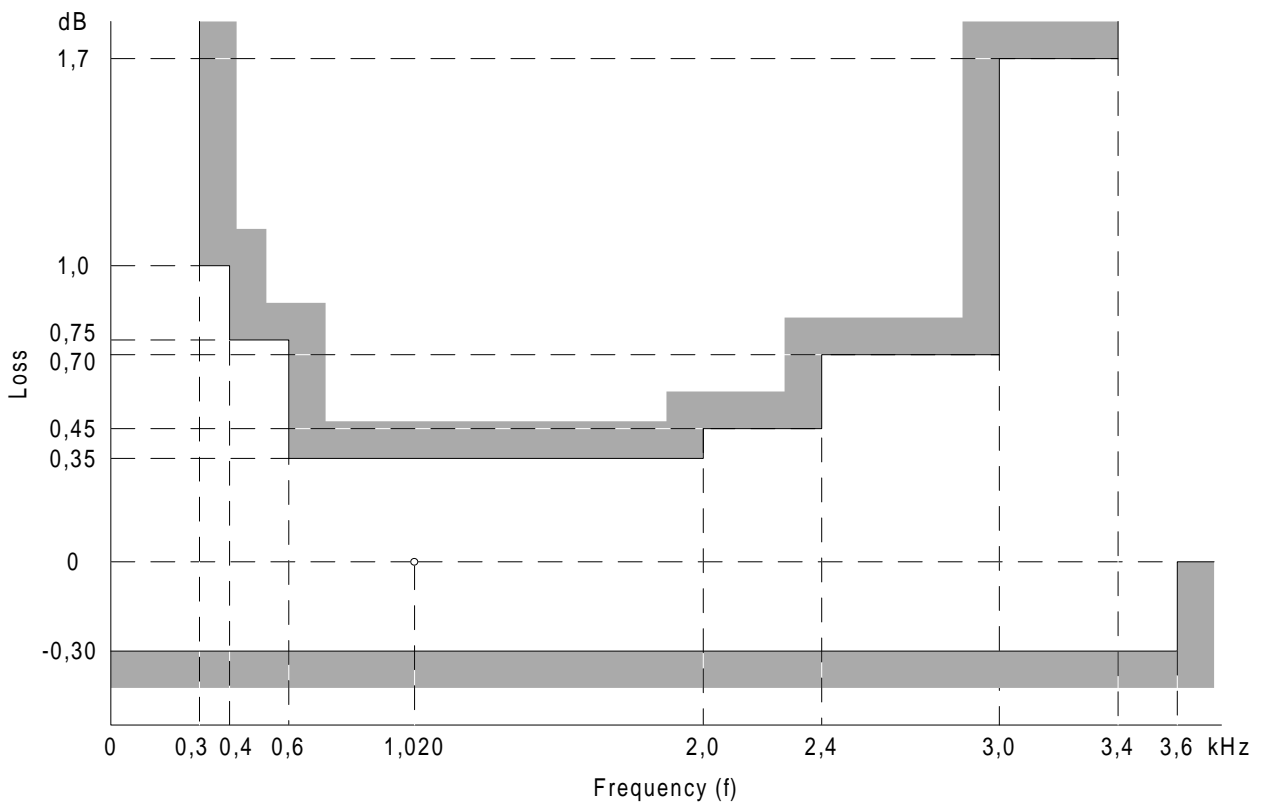

Figure 7: Loss distortion with frequency - output connection

5.3 Group delay distortion

There are no requirements for group delay distortion.

5.4 Noise

NOTE: When evaluating the PBX noise characteristics, two components of noise should be considered. One of these arises from the Pulse Code Modulation (PCM) coding/decoding process, the other from analogue sources, e.g. signalling circuits, power supply, line power feeding on both sides of a connection between two interfaces through the same PBX.

The noise arising from the PCM encoding process is limited by CCITT Recommendation G.712 [12] for all analogue interface types. The noise arising from analogue sources is considered in CCITT Recommendation G.103 [4] and ITU-T Recommendation Q.552 [28]. Its value can be different for different interface types. For a given PBX (single or included in a private network) it is important, according to clause 11 of CCITT Recommendation G.171 [8], that the constituent parts be designed in accordance with the relevant CCITT Recommendation covering the noise for public exchanges. Normally, this practice can guarantee an appropriate behaviour of the equipment. The above rules apply to both weighted noise and total distortion.

5.4.1 Weighted noise of interfaces without a feeding bridge

NOTE: For the calculation of these values, two components of noise should be considered: noise arising from the coding process and noise from the PBX power supply and other analogue sources transmitted through signalling circuits. The first component is limited by clause 9 of CCITT Recommendation G.712 [12] to -67 dBm0p for an input connection and to -70 dBm0p for an output connection. The other component is limited by clause 3 of CCITT Recommendation G.123 [7] to -70 dBm0p for each interface.

The maximum values for overall weighted noise at the outputs of a half connection shall be:

Input connection:

- -65,2 dBm0p: For equipment with signalling on the speech wires;
- -67,0 dBm0p: For equipment with signalling on separate wires.

Output connection:

- -67,0 dBm0p: for equipment with signalling on the speech wires;
- -70,0 dBm0p: for equipment with signalling on separate wires.

Compliance shall be checked by the method described in subclause A.4.5.1.1 or A.4.5.1.2, respectively.

5.4.2 Weighted noise of interfaces with a feeding bridge

NOTE: For the calculation of noise, worst case conditions are assumed. The band limiting effect of the encoder on the noise has not been taken into account.

5.4.2.1 Output connection

NOTE 1: Two components of noise should be considered. One of these, (noise arising from the decoding process) is dependent upon the output relative level. The other (power supply noise from the feeding bridge) is independent of the output relative level. The first component is limited by clause 9 of CCITT Recommendation G.712 [12] as idle channel noise to -70 dBm0p; the other component is assumed by CCITT Recommendation G.103 [4], to be 200 pWp (-67 dBmp). This latter component can be caused by the main dc power supply and auxiliary dc-dc converters.

NOTE 2: Information about the subject of noise on the dc power supply is given in Supplement No. 13 to the G-Series Recommendations (Orange Book (1980), Volume III.3).

The total psophometric power allowed at an interface with a relative output level of L_o dB shall be :

$$P_{TNo} \leq P_{AN} + 10^{0,1(90 + L_{INo} + L_o)} \text{ [pWp]}$$

The total noise level shall be:

$$L_{TNo} \leq (10 \log \left| \frac{P_{TNo}}{1 \text{ pW}} \right| - 90) \text{ [dBmp]}$$

where:

- P_{TNo} : total weighted noise power for the output connection of the digital PBX;
- P_{AN} : weighted noise power in pWp caused by analogue functions according to CCITT Recommendation G.103 [4], i.e. 200 pWp;
- L_{INo} : receiving equipment noise (weighted) in dBm0p for PCM translating equipment according to clause 9 of CCITT Recommendation G.712 [12], i.e. -70 dBm0p;
- L_o : output relative level in dBr of a half connection of a digital PBX, e.g. -5,0 to -7,0 dBr;
- L_{TNo} : total weighted noise level for the output connection of the digital PBX.

EXAMPLE: Examples of the limits for different values of L_o are listed in table 1.

Table 1: Examples of the limits for different values of L_o

L_o [dBr]	P_{TNo} [pWp]	L_{TNo} [dBmp]
-5,0	231,6	-66,4
-6,0	225,1	-66,5
-7,0	220,0	-66,6

Compliance shall be checked by the method described in subclause A.4.5.1.2.

5.4.2.2 Input connection

NOTE: Two components of noise should be considered. One of these (noise arising from the encoding process) is dependent upon the input relative level. The other (power supply noise from the feeding bridge) shall be corrected by the input relative level for calculation at the PBX output test point T_o . The first component is limited by clause 9 of CCITT Recommendation G.712 [12] as idle channel noise to -67 dBm0p; the other component is assumed by CCITT Recommendation G.103 [4] to be 200 pWp (-67 dBmp) which results in -67 dBmp - L_i at the PBX output test point T_o .

The total psophometric power allowed at the PBX output test point T_o with a relative input level of L_i shall be:

$$P_{TNI} \leq P_{AN} * 10^{-0,1L_i} + 10^{0,1(90 + L_{iNi})} \quad [\text{pWp}]$$

and the total noise level shall be:

$$L_{TNI} \leq (10 \log \left| \frac{P_{TNI}}{1\text{pW}} \right| - 90) \quad [\text{dBm0p}]$$

where:

- P_{TNI} : total weighted noise power for the input connection of the digital PBX;
- P_{AN} : weighted noise power in pWp caused by analogue functions according to CCITT Recommendation G.103 [4], i.e. 200 pWp;
- L_{iNi} : idle channel noise (weighted) in dBm0p for the input connection of a digital PBX according to clause 9 of CCITT Recommendation G.712 [12], i.e. -67 dBm0p;
- L_i : input relative level in dBr of a half connection of a digital PBX, e.g. 0 to +2.0 dBr;
- L_{TNI} : total weighted noise level for the input connection of the digital PBX.

EXAMPLE: Examples of the limits for different values of L_o are listed in table 2.

Table 2: Examples of the limits for different values of L_i

L_i [dBr]	P_{TNI} [pWp]	L_{TNI} [dBm0p]
0	399,5	-64,0
+1,0	358,4	-64,5
+2,0	325,7	-64,9

Compliance shall be checked by the method described in subclause A.4.5.1.1.

5.4.3 Unweighted noise of interfaces K2, L2, M2 and M4

There are no requirements for unweighted noise.

5.4.4 Impulsive noise of interfaces K2, L2, M2 and M4

There are no requirements for impulsive noise.

5.4.5 Single frequency noise of interfaces K2, L2, M2 and M4

The level of any unwanted single frequency (in particular the sampling frequency and its multiples), measured selectively with a bandwidth of 80 Hz in the frequency range from 4 kHz to 72 kHz at the interface of an output connection shall not exceed -50 dBm0.

NOTE: In this case "unwanted" refers to self generated noise such as feed-through of sampling frequencies and not to tones used for signalling or for normal traffic.

Compliance shall be checked by the method described in subclause A.5.1.4.

5.5 Crosstalk

A sine-wave test signal applied to an analogue interface of any input connection or a digitally simulated sine-wave test signal applied to PBX input test point T_i of any output connection, at the reference frequency of 1 020 Hz and at a level of 0 dBm0, shall not produce a level measured selectively in any other half connection (Near End Crosstalk (NEXT) and Far End Crosstalk (FEXT)) exceeding the corresponding values given in table 3.

Table 3: Crosstalk requirements (NEXT, FEXT) by using a sending signal of 0 dBm0

	Between L2 / L2 and L2 / K2	Between K2/K2	Between M4/M4 and 4-wire/2-wire
Input (FEXT)	-73 dBm0	-73 dBm0	-73 dBm0
Input (NEXT)	-73 dBm ^{*)}	-73 dBm ^{*)}	-73 dBm0
Output (FEXT)	-73 dBm ^{*)}	-73 dBm ^{*)}	-73 dBm0
Output (NEXT)	-73 dBm0	-66 dBm0	-73 dBm0
*) Not depending on relative levels.			

There are no requirements for crosstalk between the send and receive path (go-to-return) on a 4-wire interface.

Compliance shall be checked by the methods described under subclause A.4.4.

5.6 Total distortion including quantizing distortion

With a sine-wave test signal at the reference frequency of 1 020 Hz applied to the 2-wire interface of an input connection, or with a digitally simulated sine-wave signal of the same characteristic applied to the PBX input test point T_i of an output connection, the signal-to-total distortion ratio, measured at the corresponding outputs of the half connection with a proper noise weighting, specified in table 4 of CCITT Recommendation G.223 [9], shall lie above the limits for the applicable interface given in subclause 5.6.1 or 5.6.2.

NOTE: The sinusoidal test signal is chosen to obtain results independent of the spectral content of the PBX noise.

5.6.1 Values of total distortion of interfaces without a feeding bridge

The signal-to-total distortion ratio for a half connection at interfaces without feeding bridges shall lie above the limits shown:

- in figure 8, for equipment with signalling on separate wires (some M21 interfaces, some M22 interfaces and some M4 interfaces);
- in figure 9, for equipment with signalling on the speech wires (all K2 interfaces and some M22 interfaces).

NOTE 1: These values include the limits for the encoding process, given in figure 11 of CCITT Recommendation G.712 [12], and the allowance for the noise contributed via signalling circuits from the exchange power supply and other analogue sources (e.g. analogue coupling), which is limited to -70 dBm0p.

NOTE 2: Figure 8 of this ETS is identical to figure 11 of CCITT Recommendation G.712 [12].

Compliance shall be checked by the methods described in subclauses A.4.2.1.4 and/or A.4.2.2.4.

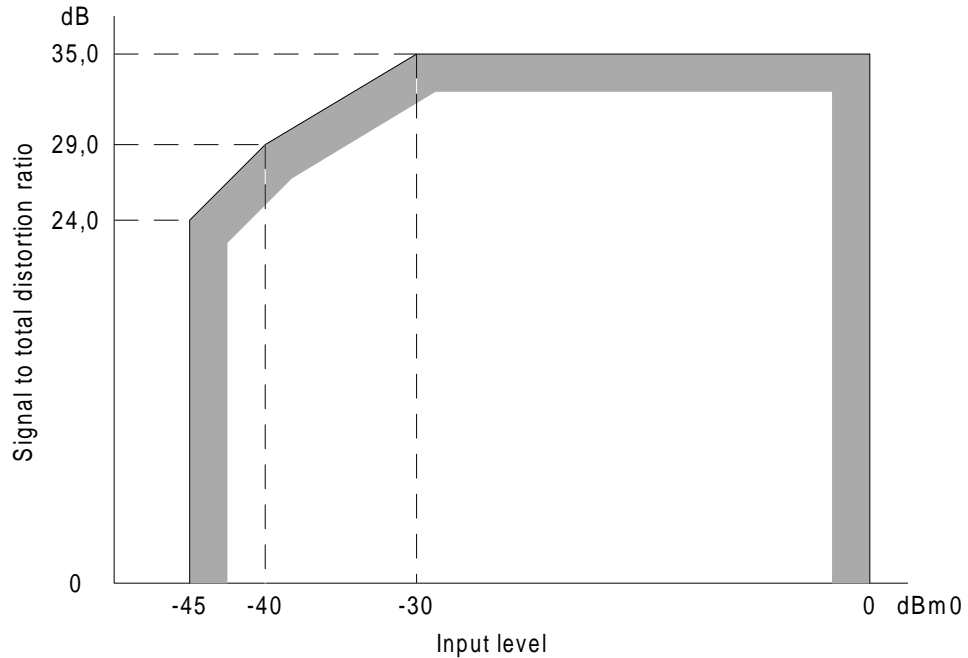

Figure 8: Limits for signal-to-total distortion ratio as a function of input level. Input or output connection. Signalling on separate wires without feeding bridge

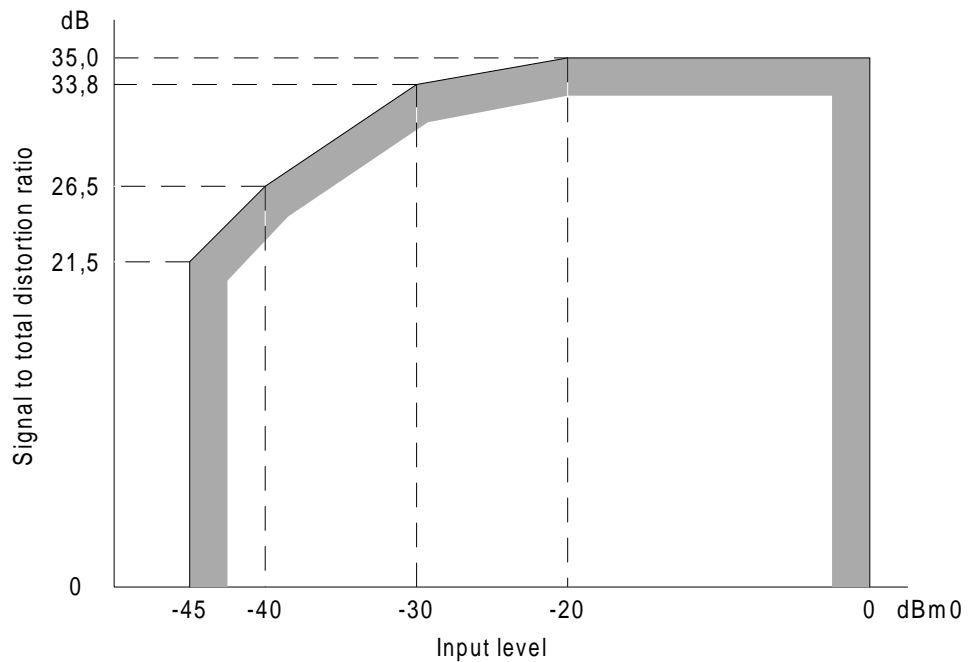

Figure 9: Limits for signal to-total distortion ratio as a function of input level. Input or output connection. Signalling on the speech wires without feeding bridge

5.6.2 Values of total distortion of interfaces with a feeding bridge

The signal-to-total distortion ratio required for a half connection at interfaces with feeding bridges shall be:

$$\frac{S}{N_T} \geq L_s + L_r - 10 \log(10^{0,1(L_s + L_r - \frac{S}{N})} + 2 * 10^{-7}) \text{ [dB]}$$

where:

- S/NT: resulting signal-to-total distortion ratio for input or output connections in digital PBXs;
- L_s: signal level of the measuring signal in dBm0;
- L_r: for input connections, input relative level L_i in dBr; for output connections, output relative level L_o in dBr;
- S/N: signal-to-total distortion ratio in dB for the equivalent value of L_s given in figure 8.

NOTE 1: One resulting template for the signal-to-total distortion ratio of input and output connections in a PBX is shown in figures 10 and 11 as an example. The relative levels are assumed to be L_i = 0 dBr and L_o = -7 dBr.

NOTE 2: The values of figures 10 and 11 include the limits for the coding process given in figure 11 of CCITT Recommendation G.712 [12] and the allowance for the noise contributed from the digital PBX power supply and other analogue sources, which is limited to -67 dBmp (200 pWp) for a L2 interface (with feeding) by CCITT Recommendation G.103 [4].

NOTE 3: For an input connection the calculation above is assumed to be the worst case. No band limiting effect of the encoder on the noise was taken into account.

Compliance shall be checked by the methods described in subclauses A.4.2.1.4 and/or A.4.2.2.4.

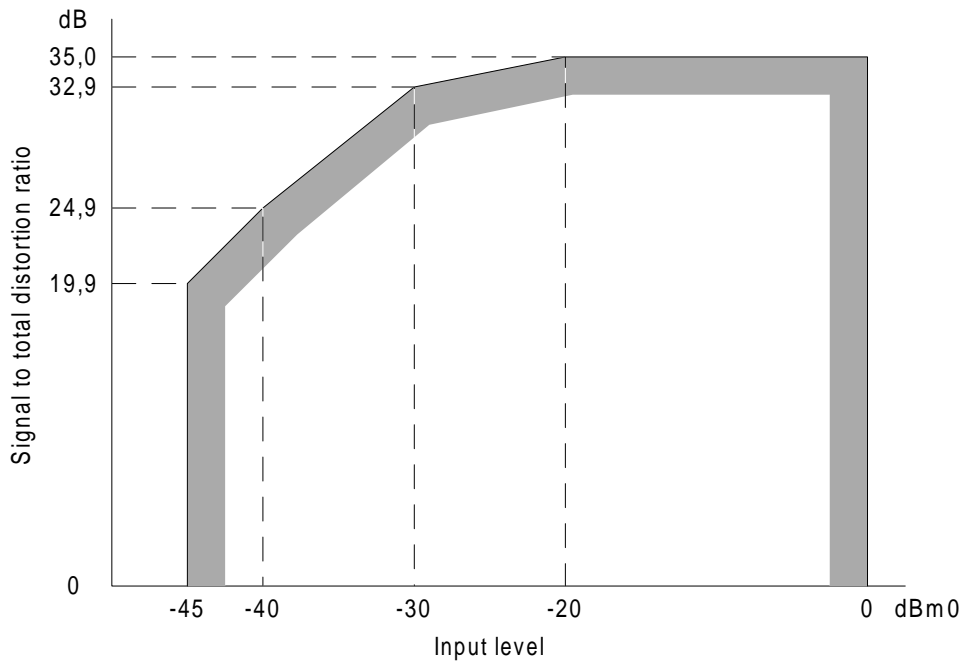

Figure 10: Limits for signal-to-total distortion ratio as a function of input level including analogue noise. Input connection (L_i = 0 dBr). Interfaces L2 and M2 with feeding bridges

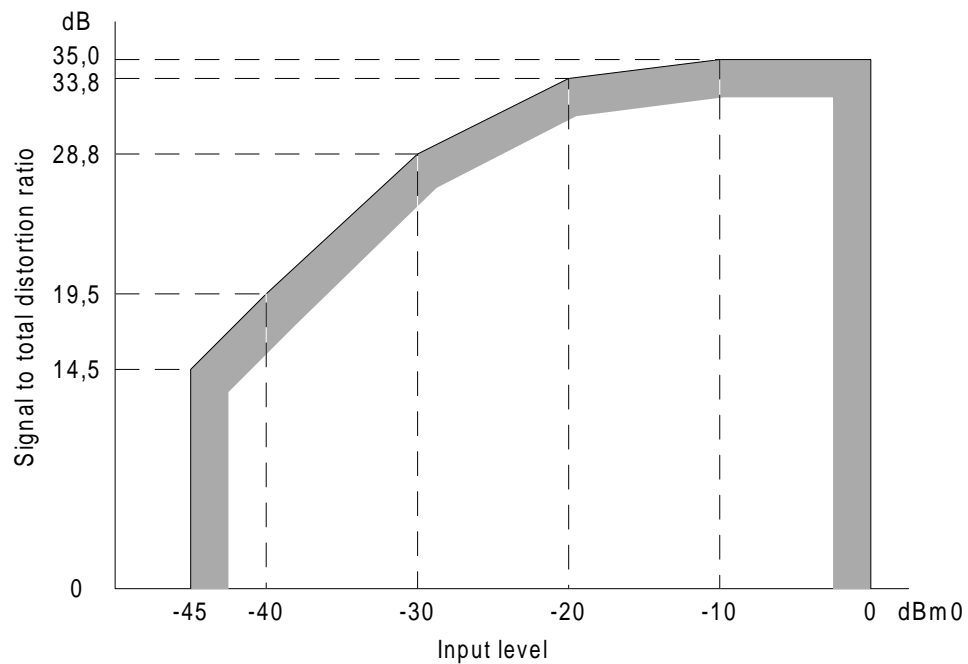

Figure 11: Limits for signal-to-total distortion ratio as a function of input level including analogue noise. Output connection ($L_o = -7$ dBr). Interfaces L2 and M2 with feeding bridges

5.7 Discrimination against out-of-band signals applied to the K2, L2, M2 and M4 input interfaces

5.7.1 Input signals above 4,6 kHz

With a sine-wave signal in the range from 4,6 kHz to 72 kHz applied to the 2-wire and/or 4-wire interface of an input connection at a level of -25 dBm0, the level of any image frequency produced in the time slot corresponding to the input connection shall be at least 25 dB below the level of the test signal.

Compliance shall be checked by the methods described in subclause A.4.2.1.5.

5.7.2 Signals below 300 Hz

There are no requirements for signals below 300 Hz.

5.8 Spurious out-of-band signals received at the K2, L2, M2 and M4 output interfaces

There are no requirements with respect to received out-of-band signals.

NOTE: For some interfaces these parameters are subject to access requirements.

5.9 Echo and stability of interfaces K2, L2 and M2

5.9.1 Terminal Balance Return Loss (TBRL)

Following the test procedure as given in subclause A.4.3.2 the TBRL, measured when terminating the 2-wire interface with the nominal value of the PBX impedance (see subclause 5.1), shall exceed the limits shown in figure 12.

NOTE: In special cases (e.g. very long lines, loaded lines, regulated subsets and so on) it might be necessary to have special arrangements for the line balancing network and the test network.

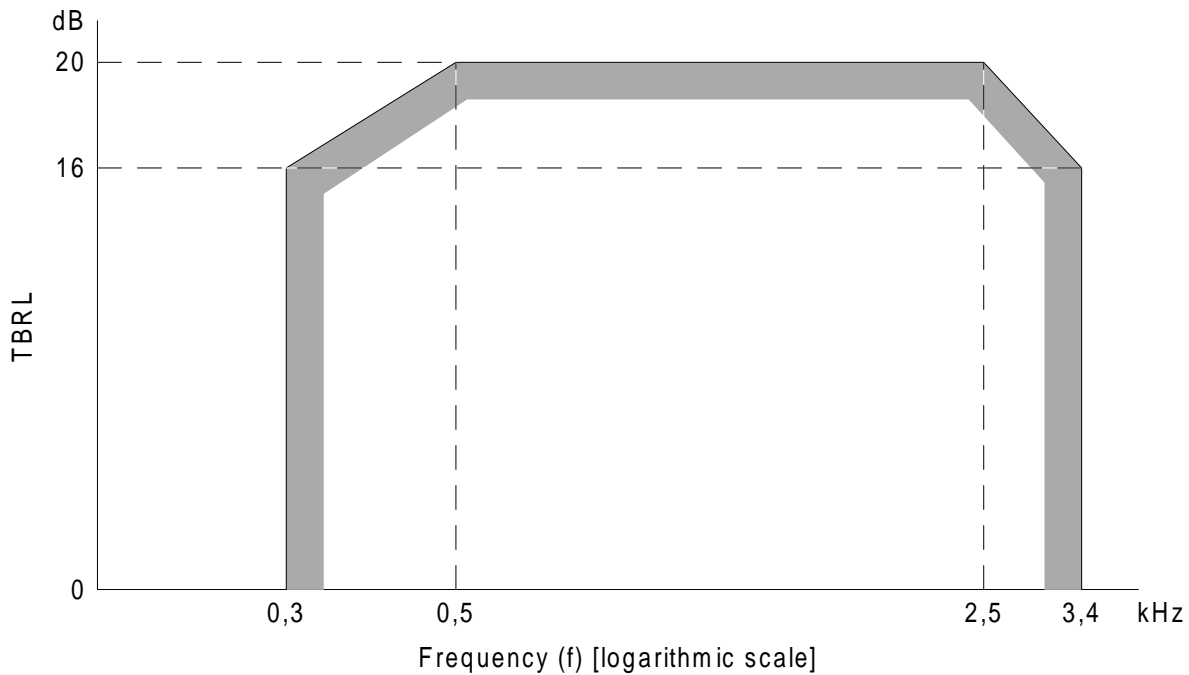

Figure 12: Limits for TBRL

5.9.2 Stability loss

The stability loss measured according to subclause A.4.3.2 from the input test point to the output test point, with worst case terminating conditions, simulated by a short circuit on the 2-wire interfaces L2 or M21 shall be at least a value stated by the supplier at all frequencies in the range 200 Hz to 3 600 Hz.

Where the interface is designed for a minimum line length, a simulation of this line shall be present when terminating the interface during compliance test.

NOTE 1: In some PBXs the 4-wire call path is left open during the dialling or before the terminating equipment has answered the call, thus preventing the effects due to short-circuit and open-circuit termination conditions.

NOTE 2: Where the digital PBX is connected to the public digital exchange using a 4-wire line, the half connection of the digital PBX may provide the total stability loss of the entire path across the public network. The value of stability loss that is required for a 2-wire interface is a matter of national control provided that the requirements of ITU-T Recommendation G.122 [6] are met. A stability loss of 6 dB at all frequencies between 200 Hz and 3 600 Hz will ensure that the ITU-T Recommendation G.122 [6] requirements are met. However, a stability loss between 6 dB and 0 dB will formally comply with the requirements of ITU-T Recommendation G.122 [6] but further study is required to provide guidance in this area.

NOTE 3: In the case that the input impedance is not equal to the balance impedance (see note in subclause 5.9.1), the stability loss under short-circuit terminating conditions may result in lower values than in the case of equal impedances.

6 Characteristics of digital interfaces

6.1 Coding law

The coding law of the digital interface shall be A-law according to CCITT Recommendation G.711 [11].

6.2 Transmission loss

The nominal transmission loss of a digital half-connection shall have a value stated by the supplier.

NOTE 1: If there is a loss or gain between the interface and the test point, this is considered as SL as defined in subclause 3.1.4.2.

The difference between the measured value of the transmission loss and the stated nominal transmission loss shall lie within the ranges -0,15 dB to +0,15 dB, for input and output loss.

NOTE 2: These differences may apply when bit integrity is not preserved between interface and test point and may arise for example from design tolerances and adjustment increments, e.g. when the interface uses A-law coding and the test point uses μ -law coding.

6.3 Error performance

There are no requirements.

6.4 Bit integrity

There are no requirements.

6.5 Bit sequence independence

There are no requirements.

7 Transmission characteristics of 3,1 kHz handset system specific telephony terminals

7.1 General

7.1.1 Applicability of transmission characteristics

The transmission characteristics of system specific telephones apply between the acoustic reference points (MRP, ERP) of the telephony terminal and the PBX digital test points, see figure 3. If the transmission system between the telephony terminal and the PBX contains analogue elements, the requirements apply at zero line length between the telephony terminal and the PBX, or the minimum line length specified by the supplier in case this is not equal to zero.

The requirements of clause 7 do not apply to telephony terminals connected to a L interface.

The measured values of the parameter STMR, LSTR, sending and receiving noise shall be corrected depending on the supplier declaration to the Sending and Receiving Loudness Rating (SLR_{nom} and RLR_{nom} , see subclause 7.2.2) in relation to the normal values $SLR = 7$ dB and $RLR = 3$ dB. The correction factor results in:

$$C = SLR_{nom} - 7 + RLR_{nom} - 3 \quad [\text{dB}]$$

7.1.2 Volume control

Unless stated otherwise, the requirements shall apply where the setting is equal or closest to the declared nominal position of the user-controlled receiving volume control, if provided.

7.2 Speech performance characteristics for handset 3,1 kHz telephony

7.2.1 Sensitivity - frequency response

7.2.1.1 Sending

The sending sensitivity - frequency response (from the MRP to the output test point) shall be within the limits shown in figure 13. All sensitivity values are dB on an arbitrary scale.

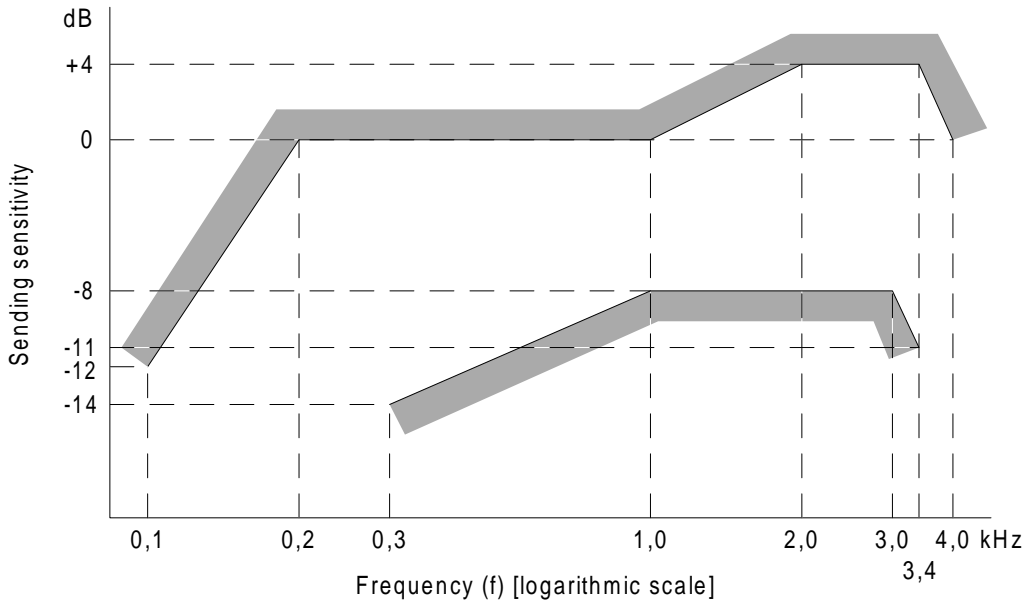

Figure 13: Sending sensitivity/frequency mask

Compliance shall be checked by the methods described in subclause A.5.2.1.1.

7.2.1.2 Receiving

The receiving sensitivity - frequency response (from the input test point to the ERP) shall be within the limits shown in figure 14. All sensitivity values are dB on an arbitrary scale.

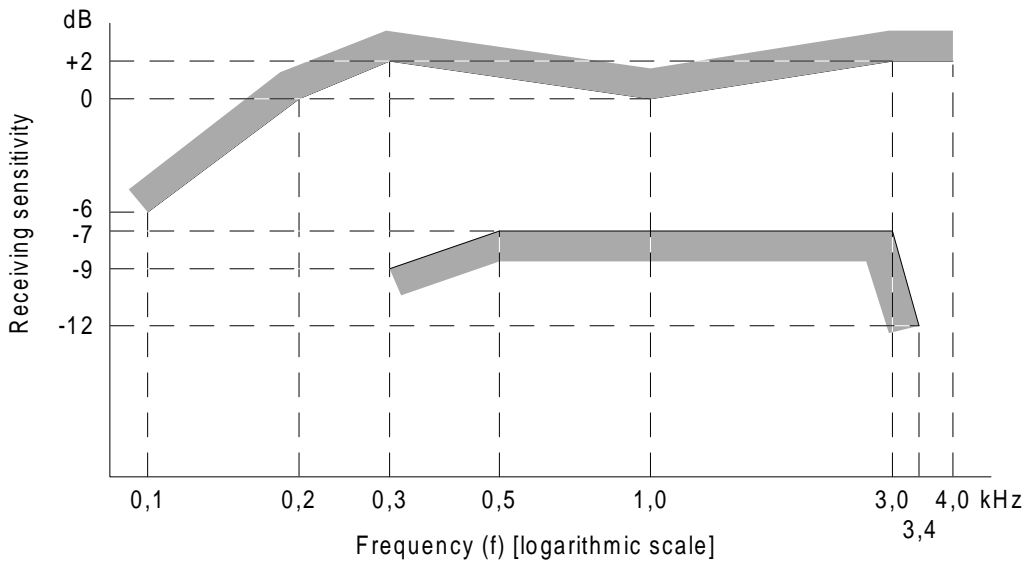

Figure 14: Receiving sensitivity/frequency mask

Compliance shall be checked by the methods described in subclause A.5.2.1.2.

7.2.2 Sending and Receiving Loudness Ratings (SLR and RLR)

The supplier shall state the nominal values of SLR and RLR.

The tolerances on SLR and RLR, including tolerances in the digital pads if present, are $\pm 3,7$ dB.

Where a user-controlled receiving volume control is provided, the RLR shall meet the nominal value for at least one setting of the control. When the control is set to the maximum, the RLR value shall not decrease (become louder) by more than 11 dB when compared with the declared nominal value of RLR.

EXAMPLE: If the nominal RLR is declared to be +3 dB, RLR shall not be less than (louder than) -8 dB when the volume control is set to maximum.

Compliance shall be checked by the methods described in subclause A.5.2.2.

7.2.3 Sidetone

7.2.3.1 Talker's sidetone

The value of the SideTone Masking Rating (STMR) shall be between 13 dB and 18 dB when the measured values are corrected in accordance to the correction factor C as defined in subclause 7.1.1 to the declared nominal values for SLR and RLR (SLR_{nom} and RLR_{nom}).

Where a user-controlled receiving volume control is provided the STMR shall meet the requirement given above at the setting where the RLR is equal (or closest) to the nominal value.

NOTE: Correction from measured STMR ($STMR_{meas}$) to the corrected value ($STMR_{corr}$) can be done using the formula.

$$STMR_{corr} = STMR_{meas} - (SLR_{meas} - SLR_{nom} + RLR_{meas} - RLR_{nom}) - C.$$

Compliance shall be checked by the methods described in subclause A.5.2.3.1.

7.2.3.2 Listener's sidetone

The value of the Listener Side Tone Rating (LSTR) shall be not less than 15 dB when the measured values are corrected in accordance to the correction factor C as defined in subclause 7.1.1 to the declared nominal values for SLR and RLR (SLR_{nom} and RLR_{nom}).

Alternatively if requested by the terminal supplier the value of the weighted average D (the difference of send sensitivities between diffuse and direct sound) shall not be less than +2 dB when measured with the ITU-T Recommendation P.57 Type 3.2 artificial ear.

Where a user-controlled receiving volume control is provided the LSTR shall meet the requirement given above at the setting where the RLR is equal (or closest) to the nominal value.

NOTE: Correction from measured LSTR ($LSTR_{meas}$) to corrected value ($LSTR_{corr}$) can be calculated using the formula.

$$LSTR_{corr} = LSTR_{meas} - (SLR_{meas} - SLR_{nom} + RLR_{meas} - RLR_{nom}) - C.$$

Compliance shall be checked by the methods described in subclause A.5.2.3.2.

7.2.4 Echo loss

The echo loss from the input test point to the output test point shall exceed 24 dB for the long-term objective and 20 dB for short-term objective with a power weighting over the voice frequency band, in accordance with ITU-T Recommendation G.122 [6], reduced by the sum of the losses in both directions of the path "test point to interface KD".

NOTE 1: These values are taken from ETS 300 283 [2].

NOTE 2: For a telephony terminal with a complete 4-wire path from the test point to the acoustic interface, this is equal to the weighted Terminal Coupling Loss (TCLw).

Compliance shall be checked by the methods described in subclause A.5.2.4.

7.2.5 Stability loss

With the handset lying on and the transducers facing a hard surface, the attenuation from the input test point to the output test point shall be at least a value stated by the supplier at all frequencies in the range 200 Hz to 3 600 Hz.

Compliance shall be checked by the methods described in subclause A.5.2.5.

7.2.6 Distortion

7.2.6.1 Sending

The system specific telephony terminal shall meet the requirements of one of the subclauses 7.2.6.1.1 or 7.2.6.1.2.

7.2.6.1.1 Method 1 (Pseudo random noise stimulus)

The test signal shall consist of a band-limited noise signal conforming to CCITT Recommendation O.131 [16]. The ratio of signal-to-total distortion (harmonic and quantizing) power of the digitally encoded signal output by the system specific telephony terminal shall lie above the limits shown in figure 15 unless the sound pressure at the MRP is greater than +5 dBPa.

Compliance shall be checked by the methods described in subclause A.5.2.6.1.1.

7.2.6.1.2 Method 2 (Sinusoidal test signal)

The test signal shall be a sine-wave with a frequency in the range 1 004 Hz to 1 025 Hz. The ratio of signal-to-total distortion (harmonic and quantizing) power of the digitally encoded signal output by the system specific telephony terminal, when passing through a noise weighting as specified in table 4 of CCITT Recommendation G.223 [9], shall lie above the limits shown in figure 16 unless the sound pressure at the MRP is greater than +10 dBPa.

Compliance shall be checked by the methods described in subclause A.5.2.6.1.2.

7.2.6.2 Receiving

The system specific telephony terminal shall meet the requirements of one of the subclauses 7.2.6.2.1 or 7.2.6.2.2.

7.2.6.2.1 Method 1 (Pseudo random noise stimulus)

The test signal shall consist of a band-limited noise signal conforming to CCITT Recommendation O.131 [16]. The ratio of signal-to-total distortion (harmonic and quantizing) power of the signal in the artificial ear shall lie above the limits shown in figure 17 unless the signal in the artificial ear is greater than +5 dBPa or is less than -50 dBPa.

Compliance shall be checked by the methods described in subclause A.5.2.6.2.1.

7.2.6.2.2 Method 2 (Sinusoidal test signal)

The test signal shall be a sine-wave with a frequency in the range 1 004 Hz to 1 025 Hz. The ratio of signal-to-total distortion (harmonic and quantizing) power of the signal in the artificial ear, when passing through a noise weighting as specified in table 4 of CCITT Recommendation G.223 [9], shall lie above the limits shown in figure 18 unless the signal in the artificial ear is greater than +10 dBPa or is less than -50 dBPa.

Compliance shall be checked by the methods described in subclause A.5.2.6.2.2.

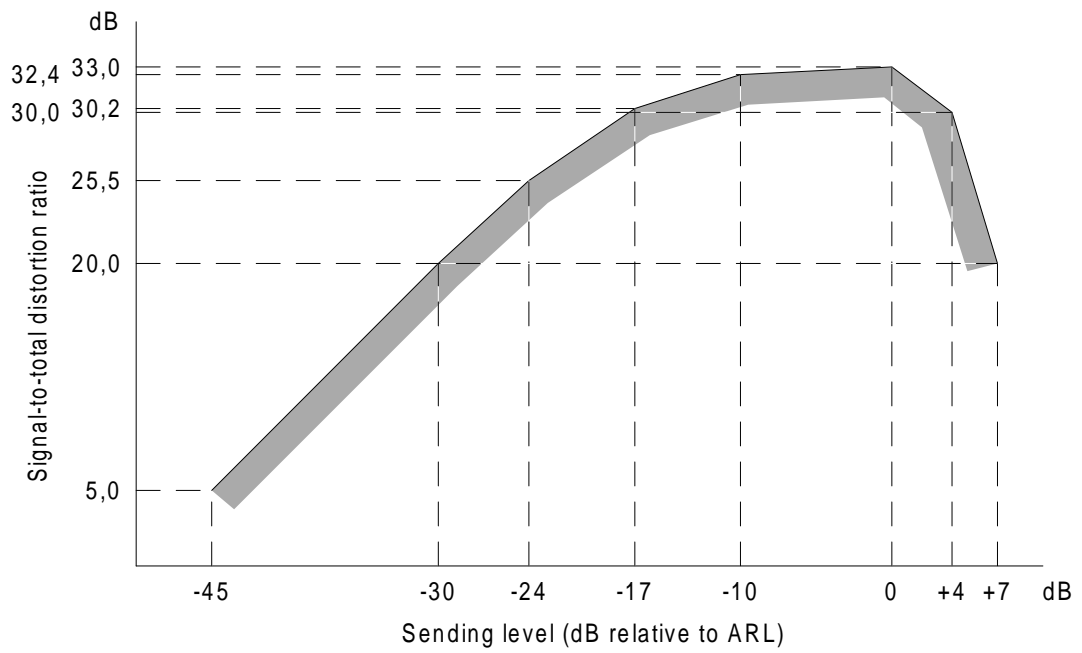

Figure 15: Limits of signal-to-distortion ratio, sending, method 1

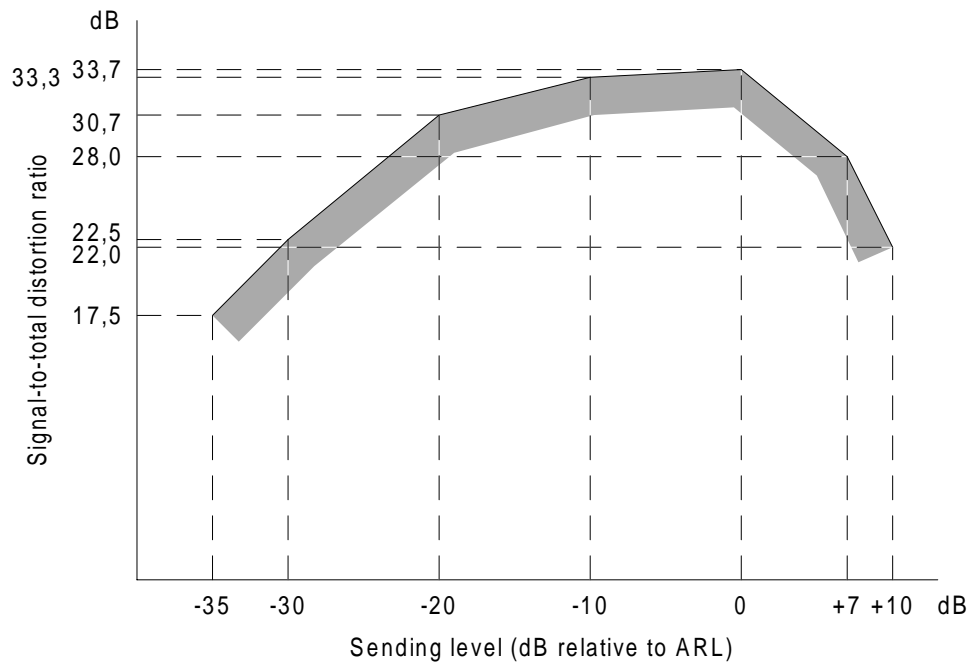

Figure 16: Limits for signal-to-distortion ratio, sending, method 2

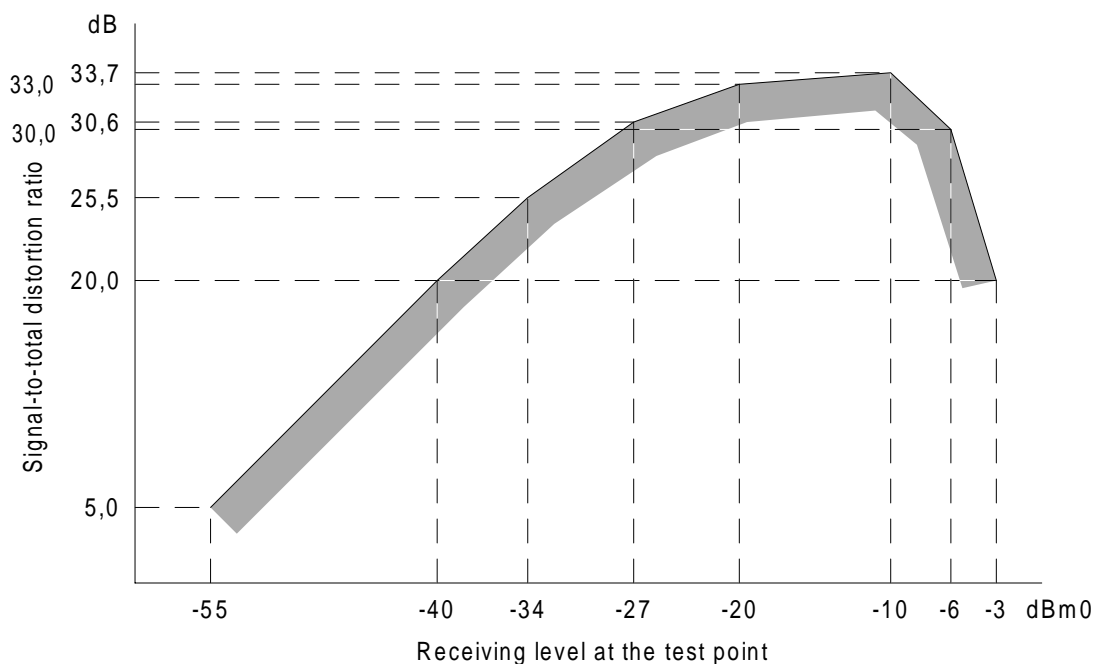

Figure 17: Limits of signal-to-distortion ratio, receiving, method 1

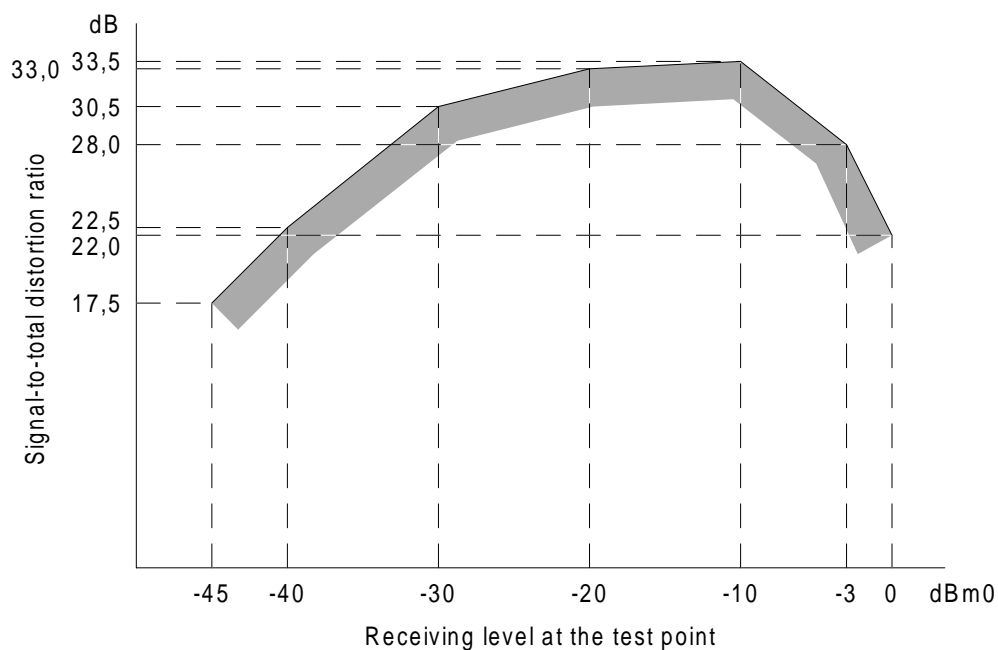

Figure 18: Limits for signal-to-distortion ratio, receiving, method 2

7.2.6.3 Sidetone distortion

The third harmonic distortion generated by the system specific telephony terminal shall not be greater than 10 %.

Compliance shall be checked by the methods described in subclause A.5.2.6.3.

7.2.7 Variation of gain with input level

7.2.7.1 Sending

The gain variation relative to the gain for ARL shall be within the limits shown in figure 19. The test signal shall be a sine-wave with a frequency in the range 1 004 Hz to 1 025 Hz.

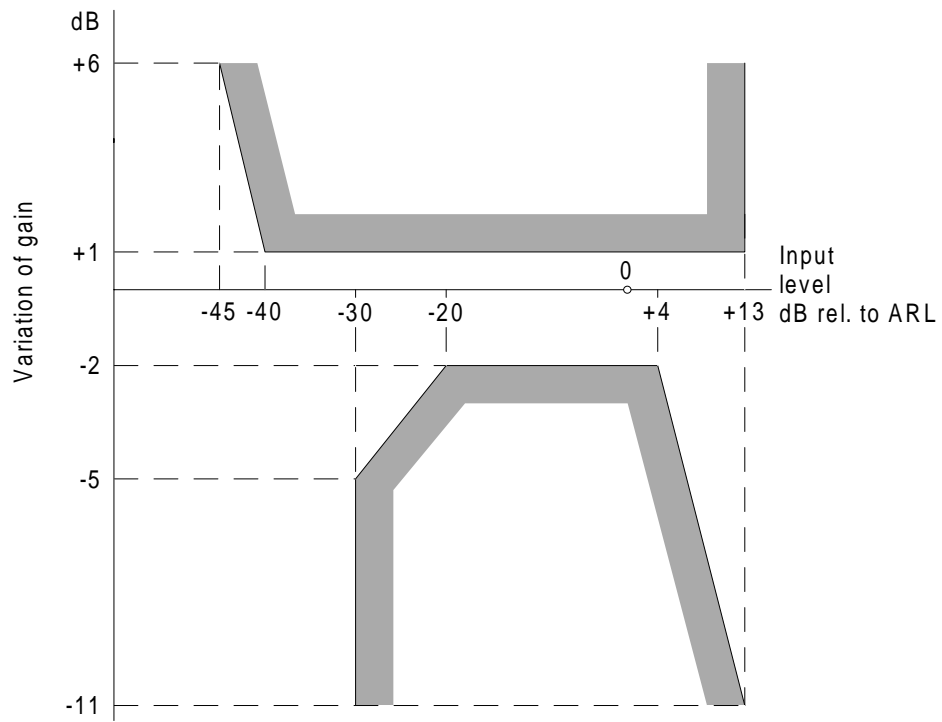

Figure 19: Variation of gain with input level (sending)

Compliance shall be checked by the methods described in subclause A.5.2.7.1.

7.2.7.2 Receiving

The gain variation relative to the gain at an input level of -10 dBm₀ shall be within the limits shown in figure 20. The test signal shall be a sine-wave with a frequency in the range 1 004 Hz to 1 025 Hz.

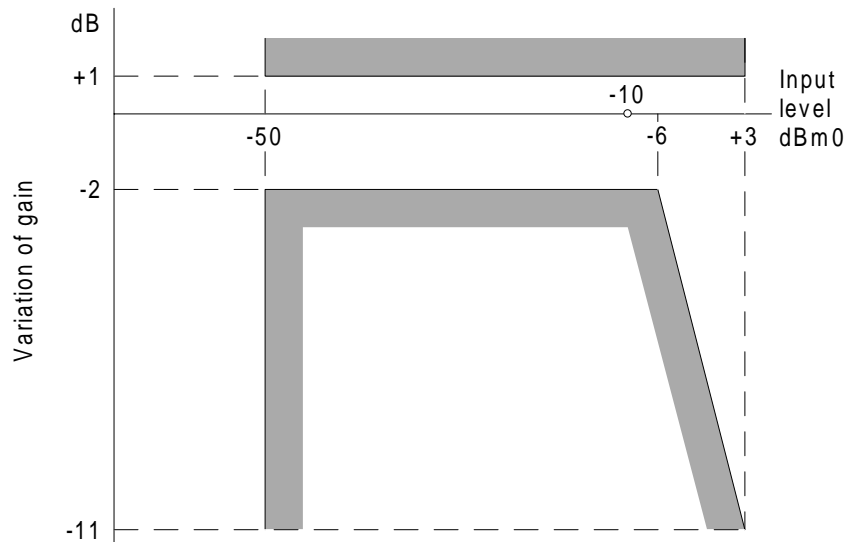

Figure 20: Variation of gain with input level (receiving)

Compliance shall be checked by the methods described in subclause A.5.2.7.2.

7.2.8 Out-of-band signals

7.2.8.1 Discrimination against out-of-band input signals (sending)

With any sine-wave signal between 4,6 kHz and 8 kHz applied at the MRP at a level of -4,7 dBPa, the level of any image signal in the frequency range 300 Hz to 3,4 kHz produced at the output test point shall be less than a reference level obtained at 1 kHz (-4,7 dBPa at MRP) by at least the amount (in dB) described in figure 21.

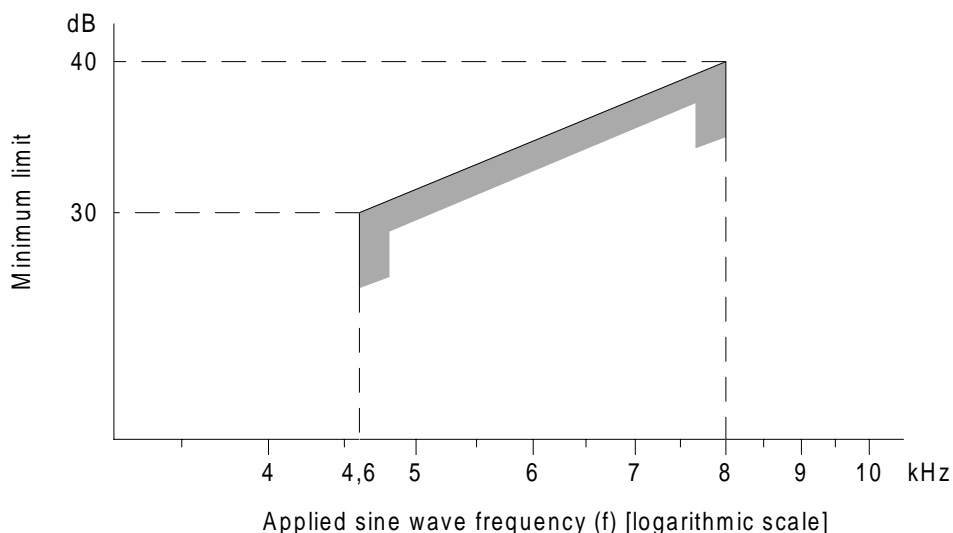

Figure 21: Discrimination levels (sending)

Compliance shall be checked by the methods described in subclause A.5.2.8.1.

7.2.8.2 Spurious out-of-band signals (receiving)

With a digitally simulated sine-wave signal in the frequency range of 300 Hz to 3,4 kHz and at a level of -10 dBm0 applied at the input test point, the level of spurious out-of-band image signals in the frequency range of 4,6 kHz to 8 kHz measured selectively in the artificial ear shall be less than the in-band acoustic level produced by a digital signal at 1 kHz set at the level described in figure 22.

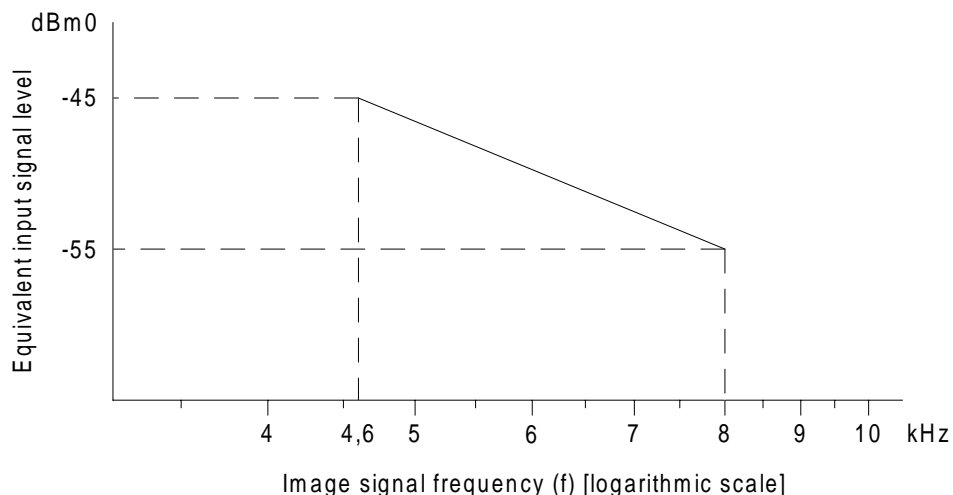

Figure 22: Discrimination levels (receiving)

Compliance shall be checked by the methods described in subclause A.5.2.8.2.

7.2.9 Noise

7.2.9.1 Sending

The noise in the sending direction shall not exceed $-(64 + \text{SLR}_{\text{nom}} - 7)$ dBm0p.

Compliance shall be checked by the methods described in subclause A.5.2.9.1.

7.2.9.2 Receiving

If no user-controlled receiving volume control is provided, or, if it is provided, at the setting of the user-controlled receiving volume control at which the RLR is equal (or closest) to the declared nominal value, the noise measured in the artificial ear contributed by the receiving equipment alone shall not exceed $-(57 + \text{RLR}_{\text{nom}} - 3)$ dBPa(A) when driven by a PCM signal corresponding to the decoder output value number 1.

Compliance shall be checked by the methods described in subclause A.5.2.9.2.

7.2.9.3 Level of sampling frequency (receiving)

The level of 8 kHz measured selectively in the artificial ear shall be less than -70 dBPa.

Compliance shall be checked by the methods described in subclause A.5.2.9.3.

8 Characteristics for connections between two interfaces

8.1 General

Information about performance when interconnecting two interfaces applies only where this interconnection is intended, and when the interfaces are interconnected. These Interfaces can be electrical or acoustic interfaces.

NOTE: The information in this clause is mainly for the benefit of transmission planners.

8.2 Transmission loss between interfaces

The value of transmission loss between interfaces shall be stated by the supplier.

8.3 Quantizing distortion units (qdu)

The number of qdu present in a connection between interfaces shall be a value stated by the supplier.

NOTE: The number of qdu is 1 between two analogue interfaces if no digital loss pad is introduced in the connection, or if the digital pad has a value equal to 6 dB ($20 \cdot \log(2) = 6,02$ dB).

8.4 Mean one-way transmission time

The mean one way transmission time in a connection between two interfaces shall be a value stated by the supplier.

8.5 Stability loss

8.5.1 Stability loss of interfaces connected to a KD interface

The nominal stability loss of connections to a KD interface shall be at least 6 dB at all frequencies in the range 200 Hz to 3 600 Hz, when measured from the input of the KD interface to the output of the KD interface. However, where the national transmission plan ensures that extra loss is added in the public network for international calls, the stability loss value in this clause shall be reduced by the value of such extra loss.

Termination of 2-wire interfaces connected to KD shall be as specified in subclause 5.9.2. Termination of a system specific telephony terminal interface connected to KD shall be as specified in subclause 7.2.5.

8.5.2 Stability loss of interfaces connected to M4 or MD interfaces

The nominal stability loss of connections to M4 or MD interfaces shall be at least a value stated by the supplier at all frequencies in the range 200 Hz to 3 600 Hz, when measured from the input of the M4 or MD interface to the output of the M4 or MD interface. Termination of 2-wire interfaces connected to M4 or MD shall be as specified in subclause 5.9.2. Termination of a system specific telephony terminal interface connected to M4 or MD shall be as specified in subclause 7.2.5.

Annex A (normative): Digital PBX transmission characteristic measurements

A.1 General

A.1.1 Common measurement configurations

A.1.1.1 Environmental conditions

The test shall be performed under the following environmental conditions:

- ambient temperature in the range from 15° C to 35° C;
- relative humidity in the range from 5 % to 85 %;
- air pressure from 86 kPa to 106 kPa.

A.1.1.2 Operational conditions

There is a general rule, that all measurements of transmission characteristics shall be performed under nominal operating conditions, unless stated otherwise. This is mainly relevant to all 2-wire and 4-wire analogue interfaces involved in a connection. In many cases it is necessary that the test equipment includes additional auxiliary test equipment, to simulate nominal operating conditions e.g. dc-feed (see figure A.1). For more information, see clause A.3.

If test equipment are used to establish the test connections (e.g. signalling adapters) it shall be switched off after reaching the talking state or, where this is not possible, their influence on the test results shall be negligible.

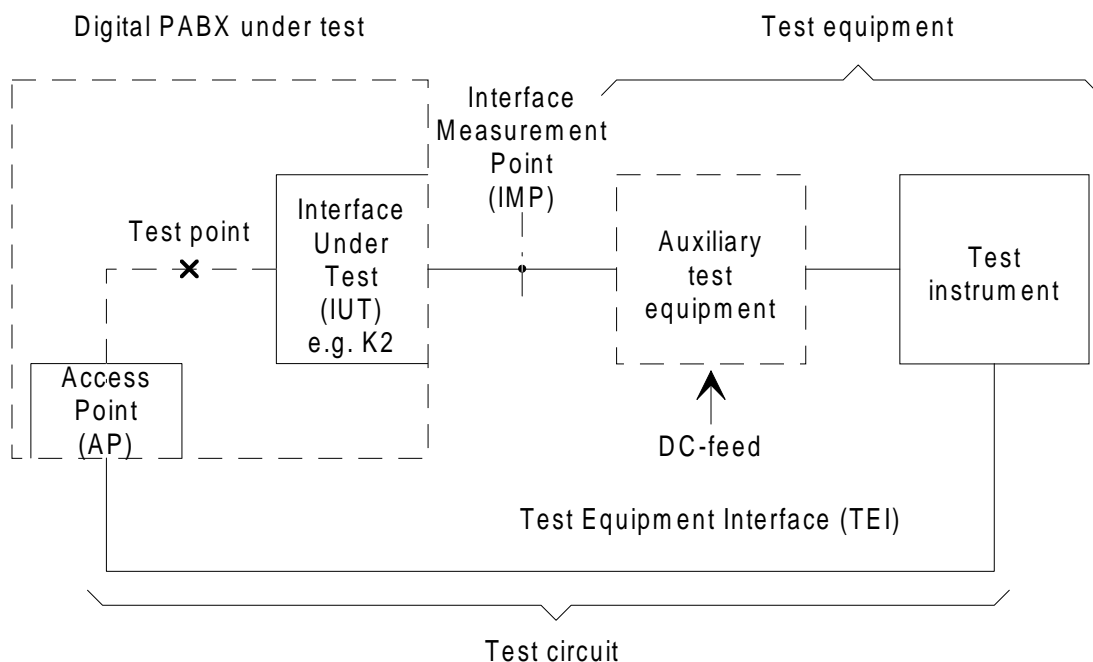

Figure A.1: Basic measurement configuration

A.1.2 Digital signal processing

All digital signal processing devices, which affect bit integrity of the 64 kbit/s speech-path within a digital PBX, e.g. digital loss or gain, digital echo control devices etc., shall be rendered inoperative, when measuring the transmission parameters of this ETS. However, if the Nominal Transmission Loss (NL) is implemented by a digital loss or gain, the parameters "Nominal value" and "Tolerance" of the relative levels for input and output connections shall be measured with digital loss or gain switched operative (see also clause 4).

A.1.3 Reference frequency

The reference frequency shall be 1 020 Hz for test frequency generating circuits or instruments, that provide reference test frequencies. The specified frequency tolerance shall be +2 Hz to -7 Hz.

A.1.4 Impedance

Unless otherwise specified, measurements at analogue interfaces shall be made under matched conditions to the nominal impedance Z_r of the Interface Under Test (IUT). The interpretation of this statement is, that the nominal PBX impedance is used as the internal impedance of the test signal generator and the analogue level meter, i.e. test instruments with integrated test impedances.

NOTE: For more flexibility it may be preferable to use a low-impedance generator and a high-impedance meter in conjunction with a suitable external test impedance, which corresponds to an exact matching to the nominal PBX impedance.

A.1.5 Measurement points

As far as analogue 2-wire or 4-wire interfaces are considered, the Interface Measurement Point (IMP) shall be at the first point of isolation as indicated by the PBX supplier, which provides testing access to the PBX and all external cabling. This means, that all cabling between this point and the interface card in the system, are included in the test results.

NOTE: For the test point used in conjunction with input/output-measurements and its access, see subclause 3.1.2.

A.1.6 Test Instruments

For the choice of test instruments the following features shall be considered:

The test instrumentation consists of the following four functional units:

- an analogue signal generator A to apply test signals to the IMP of the PBX under test e.g. via an auxiliary test equipment (see also subclause A.1.5 and clause A.3). For more information, see subclause 3.2 of ITU-T Recommendation O.133 [18];
- an analogue signal analyser B to process received signals from the IMP of the PBX under test e.g. via an auxiliary test equipment (see also subclause A.1.5 and clause A.3). For more information, see subclause 3.3 of ITU-T Recommendation O.133 [18];
- a digital signal generator C to apply test-signals to the Access Point (AP) or the Test Equipment Interface (TEI) of the PBX under test (see also clause A.2). For more information, see subclause 3.4 of ITU-T Recommendation O.133 [18];
- a digital signal analyser D to process signals received from the AP or the TEI of the PBX under test (see also clause A.2). For more information, see subclause 3.5 of ITU-T Recommendation O.133 [18].

As a general objective the accuracy of the test instruments shall be an order of magnitude better than the relevant performance limits of the PBX under test.

In some cases it may not be possible to meet this objective due to technical and cost limitations.

For guidance to the capability and the accuracy of the test instrumentation refer to annex B.

A.1.7 Test levels

At the reference frequency, test levels at analogue interfaces are defined in terms of apparent power relative to 1 mW.

Where no value is given, the test level shall be -10 dBm0. However, test levels may be restricted to a maximum absolute input and output power level as stated by the supplier.

At frequencies different from the reference frequency, test levels are defined as having the same voltage as the test level at the reference frequency. Measurements are based on the use of a test generator with a frequency independent electro motive force (emf).

A.1.8 Disturbing effects

Where the digital input of the test point is not used, a quiet code shall be applied.

Measurements, which involve low output signal levels, or when measuring individual spectral components of a signal, shall be performed using frequency selective equipment. A bandwidth of 80 Hz is recommended.

A.1.9 Alternative test methods

Laboratories may use other test methods provided they are electrically equivalent to those specified in this ETS.

A.2 Test point and access to the test point

A.2.1 Basic principle

In this ETS, most of the parameters specified are for input half connections and output half connections. In these cases the parameters are referred to a "test point" as given in subclause 3.1.2.1 and figure 3. However, this is only a virtual point for specification purposes and might be considered as a "reference point".

For measurements, one or more specific AP shall be available to provide a suitable "path" between the test instrument and the test point. In this path, a part, or all of the switching network will be included. To ensure, that the influence on the results of this path is negligible, bit integrity is required.

NOTE: This physical access to the test point might be advantageous also for maintenance purposes. However, there is no obligation to provide AP on production systems in the field.

A.2.2 Physical nature of test access

For measurement purposes, an AP shall be digital in its nature. To avoid additional adaptation equipment between AP and test instrument, the following interface types shall be used with the test access:

- 64 kbit/s co-directional, according to clause 1 of CCITT Recommendation G.703 [10];
- 2 048 kbit/s, according to clause 6 of CCITT Recommendation G.703 [10];
- 192 kbit/s, according to CCITT Recommendation I.430 [13].

The synchronization of the test instrument from the digital PBX under test shall be ensured.

The coding law of the test point shall be either A-law or μ -law according to CCITT Recommendation G.711 [11].

NOTE: A-law is preferred.

A.2.3 Set-up of test connections

Measurements of half connections are normally performed such that a complete bi-directional connection between the AP, via the test point (switching matrix) and the IUT is established.

It is the responsibility of the supplier to make it possible to measure all specified input and output parameters as given in this ETS for all types of interfaces provided by the PBX such as K, L and M. Furthermore, it shall be possible to perform conformance tests in every connection configuration of the tested interfaces, where such a connection alters the transmission parameters.

Due to these facts, it might be necessary in some cases, to provide an additional software support for the control of test connections. For test laboratories, documentation, which gives instructions for use of the test access, shall be made available.

A.3 Auxiliary test equipment

A.3.1 General

As already mentioned in subclause A.1.1.2, measurements shall be performed as far as possible under nominal operating conditions. For this purpose, test feeding bridges in conjunction with a separate dc power supply and hold circuits are used at analogue interfaces, not only to keep the measured connection in the talking state, but also to provide a dc flowing, since the transmission characteristics of interfaces may vary with dc.

Furthermore, some modern test instruments (see subclause A.1.6) may only consist of an analogue or digital signal generator and signal receiver, but may not include additional bridge circuits as necessary, e.g. for return loss measurements. In those cases, external equipment shall be used in conjunction with the main PCM test instrument. Where artificial cables are included in the test circuit their characteristics shall be defined and standardized.

Every auxiliary test equipment which is part of the test circuit, shall have negligible influence on the test results.

NOTE: The values of inductances and capacitances used in auxiliary test equipment, may be sufficient for measurements with nominal input or test impedances of 600 Ω resistive, but not for all capacitive complex impedances.

Considering all these facts, the following subclauses will give minimum requirements for all important auxiliary test equipment, to ensure, that their influence on the test results is negligible.

A.3.2 dc power supply

If dc power supply units are used in conjunction with a feeding bridge as part of the test circuit, any superimposed noise voltage shall have negligible influence on the test results. More information is given in the relevant subclauses of clause A.4.

A.3.3 Transmission Decoupling Unit (TDU)

A TDU is used to either feed a dc into the appropriate analogue 2-wire point of the system under test, or to provide a dc loop.

The basic circuit of a TDU is shown in figure A.2. The realization shall provide also a negligible influence when used in common mode configuration as necessary for impedance unbalance measurements, in conjunction with earthed dc power supply.

If TDUs with active elements are used, linearity over the full range of test signal level and the respective noise performance shall be taken into account.

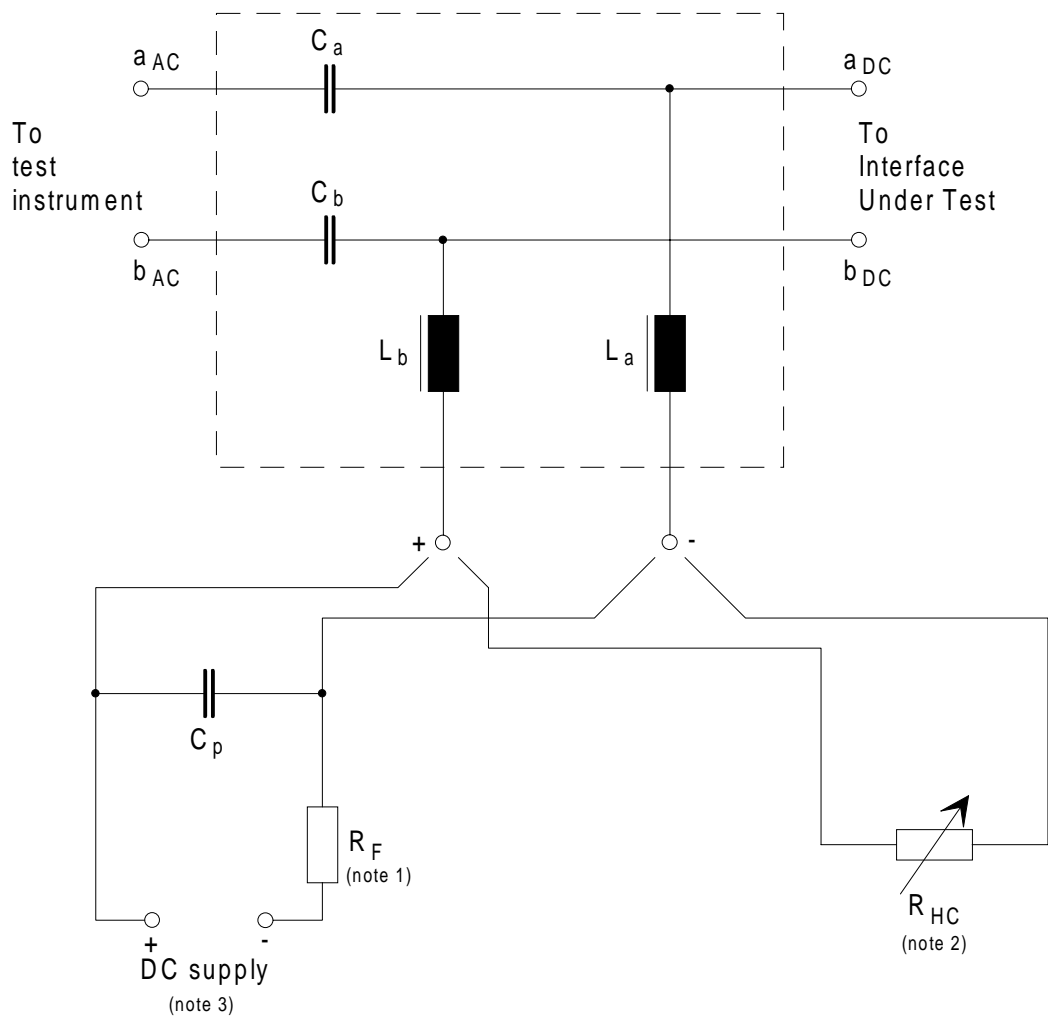

- NOTE 1: The value of the resistor R_F is the value quoted for the nominal resistance of the feeding arrangements being used. The actual value of R_F is adjusted to allow for the resistance value of inductors L_a and L_b .
- NOTE 2: The variable resistor R_{HC} should be adjustable to give the required range of holding resistance. R_{HC} should allow for the resistances of inductors L_a and L_b .
- NOTE 3: The dc supply should be such, that the full range of dc to be tested can be achieved. This could be by use of a low impedance dc voltage source in series with a variable resistor which replaces R_F or a variable constant current source.

Figure A.2: Basic circuit diagram of a Transmission Decoupling Unit (TDU)

The following characteristics of a TDU have to be considered as minimum requirements and shall be met over the full range of dc.

- NOTE 4: Measurements of the following high values for a single TDU, mainly return loss and insertion loss requirements in the full dc range may be difficult or impossible. Therefore, it is recommended to connect two TDUs of the same type in a suitable configuration and perform the measurements including both TDUs. In this case, the requirements for insertion loss is 1,0 dB and 0,1 dB respectively and for return loss 6 dB less than the following values for a single TDU.

Return loss:	≥ 33 dB	in the range from	200 Hz	to	< 500 Hz
	≥ 40 dB	in the range from	500 Hz	to	< 2 500 Hz
	≥ 33 dB	in the range from	2 500 Hz	to	4 000 Hz

measured with reference to a capacitive complex impedance (see annex E).

Insertion loss: for 50 Hz to 200 Hz < 0,5 dB
 for 200 Hz to 4 000 Hz < 0,05 dB
 for 4 000 Hz to 72 kHz < 0,5 dB

Together with earthed dc power supply a TDU shall meet the following inherent balance requirements:

Inherent balance: for 50 Hz to 20 kHz : LCL and LCTL \geq 60 dB
 for 200 Hz to 3 400 Hz : LCL and LCTL \geq 75 dB

measured according to figures 1 and 3 of CCITT Recommendation O.9 [14], with respect to the bridged leads "+" and "-" of the TDU.

A.3.4 External hybrid for return loss measurements

The hybrid shown in figure A.3 may be used for return loss measurements at 2-wire and 4-wire analogue ports.

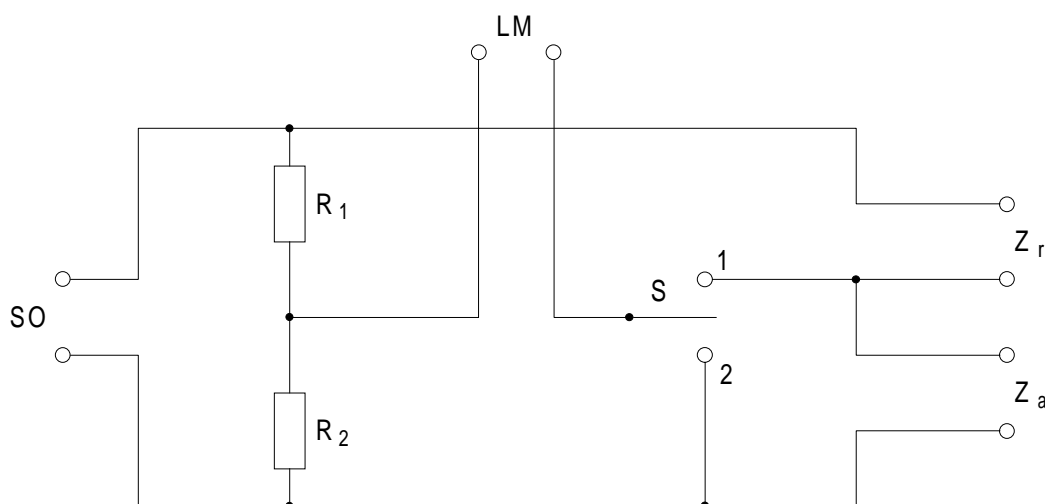

- R₁, R₂ Resistors in the range from 100 Ω to 800 Ω (preferably 600 Ω), matched to each other \leq 0,2 %.
- S Switch (for the use of this switch see clause A.4).
- SO Sinusoidal oscillator, output balanced, earth free, low impedance: \leq 10 Ω.
- LM Level meter, input balanced, earth free, high impedance \geq 20 kΩ.
- Z_r Connection point for reference impedance test network.
- Z_a Connection point to item under test.

Figure A.3: Return Loss measuring Hybrid (RLH)

If the above mentioned values are met, then the inherent return loss in the frequency range from 200 Hz to 4 000 Hz of such an arrangement is more than 45 dB. For the purpose of testing the accuracy of such an equipment, values of $600 \Omega \pm 0,1 \%$ each are recommended for Z_r and Z_a.

A.3.5 Test Equipment Interface (TEI)

The interface of the test equipment connected to the digital IUT shall be capable of providing the signalling and supervision necessary for the PBX to be working in all test modes.

A.4 Specific measurements

A.4.1 General procedure for measurement arrangements

Connect the IUT, using the arrangements for the measurement to be performed as specified in the appropriate subclause below, to both the IMP and the AP for half connection measurements.

For interfaces which have an external dc feed, the TDU shall have a suitable dc supply connected to the + / - terminals.

For interfaces which have an internal dc feed, the TDU shall have a suitable variable resistor connected to the + / - terminals.

For interfaces which have no dc requirements being ac only circuits, the + / - terminals are short circuits or the TDU is not used.

Set the connection to the test point from the IUT such, that the connection case to be validated is established as detailed in the instructions provided for test purposes.

In setting up this connection, any signalling protocols which are necessary between the IUT and external connections, shall be exercised to ensure the correct conditioning of the IUT prior to the commencement of testing.

For IUTs which use in-band signalling this shall be disabled where it will interfere with the measurement being performed.

For those IUTs with dc, repeat the measurement for a representative series of dc values, which cover the range of dc which the IUT is expected to handle.

Set the connection between the test point and the AP for half connection measurements and between two IUTs for full connection measurements.

When testing a 4-wire interface, the input or output connection which is not used in the measurement being carried out, shall be terminated in its nominal impedance Z_r .

NOTE: For the relationship between dBr, dBm, dBm0 and correction factors, reference may be made to annex C.

Perform the measurement in the specified manner and check the results against the values or limits laid down in this ETS.

A.4.2 Analogue interfaces, half connection measurements

A.4.2.1 Input connections

A.4.2.1.1 Input transmission loss / input short-term variation of loss with time

- a) Connect the IMP and the AP as shown in figure A.6 for 2-wire interfaces and figure A.7 for 4-wire interfaces, where:

A = signal generator (sine-wave);

C = digital signal generator;

D = digital level measuring instrument.

- b) Set A at the IMP to provide the input level of - 10 dBm0 as stated for the IUT at a frequency of 1 020 Hz.
- c) Measure the output level at the AP on D and record the value.

A.4.2.1.2 Input variation of gain with input level

- a) Connect the IMP and the AP as shown in figure A.6 for 2-wire interfaces and figure A.7 for 4-wire interfaces, where:

A = signal generator (sine-wave);

C = digital signal Generator;

D = digital level measuring instrument (frequency selective).

- b) Set A at the IMP to provide a representative series of input levels in the range specified in this ETS at a frequency of 1 020 Hz.

Set C at the AP to input a quiet code (see subclause A.1.8).

NOTE: To avoid overloading the codec, it may be necessary to perform this test using the actual input relative level of the interface as required in subclause 5.2.

- c) Measure the output level at the AP on D and record the value for each input level used.

A.4.2.1.3 Input loss distortion with frequency

- a) Connect the IMP and the AP as shown in figure A.6 for 2-wire interfaces and figure A.7 for 4-wire interfaces, where:

A = signal generator (sine-wave);

C = digital signal generator;

D = digital level measuring instrument.

- b) Set A at the IMP to provide the input level of - 10 dBm₀ as stated for the IUT at a representative series of frequencies in the range specified in this ETS. One of the frequencies used for measurement shall be the reference frequency 1 020 Hz.

- c) Measure the output levels at the AP on D and record the value for each input frequency used.

A.4.2.1.4 Input total distortion including quantizing distortion

- a) Connect the IMP and the AP as shown in figure A.6 for 2-wire interfaces and figure A.7 for 4-wire interfaces, where:

A = signal generator (sine-wave);

C = digital signal generator;

D = digital level measuring instrument;

A and D shall form part of the same instrument, which shall be capable of performing total distortion measurements.

- b) Set A at the IMP to provide a representative series of input levels in the range specified in this ETS at a frequency of 1 020 Hz.

Set C at the AP to input a quiet code (see subclause A.1.8).

- c) Measure the total distortion and record the value for each input level used.

A.4.2.1.5 Discrimination against out-of-band signals applied to the input interface

- a) Connect the IMP and the AP as shown in figure A.6 for 2-wire interfaces and figure A.7 for 4-wire interfaces, where:

A = signal generator (sine-wave 4,6 kHz to 72 kHz);

C = digital signal generator;

D = digital level measuring instrument.

- b) Set A at the IMP to provide an input level of -25 dBm₀ as stated for the IUT at a representative series of frequencies in the range specified in this ETS.

Set C at the AP to input a quiet code (see subclause A.1.8).

- c) Measure the output levels at the AP on D and record the value for each input frequency used. If the result is less than 25 dB below the input level of the test signal when D is in the voice frequency bandwidth mode, then individual spectral frequency measurements shall be performed to determine compliance.

NOTE: See subclause A.1.8 for information on frequency selective measurements.

A.4.2.2 Output connections

For these connections, D is required to enable synchronization of the test apparatus.

A.4.2.2.1 Output transmission loss / output short-term variation of loss with time

- a) Connect the IMP and the AP as shown in figure A.8 for 2-wire interfaces and figure A.9 for 4-wire interfaces, where:

B = level measuring instrument;

C = digital signal generator;

D = digital level measuring instrument.

- b) Set C at the AP to provide the input level of -10 dBm₀ as stated for the IUT at a frequency of 1 020 Hz.

- c) Measure the output level at the IMP on B and record the value.

A.4.2.2.2 Output variation of gain with input level

- a) Connect the IMP and the AP as shown in figure A.8 for 2-wire interfaces and figure A.9 for 4-wire interfaces, where:

B = level measuring instrument (frequency selective);

C = digital signal generator;

D = digital level measuring instrument.

- b) Set C at the AP to provide a representative series of input levels in the range specified in the standard at a frequency of 1 020 Hz.

- c) Measure the output level at the IMP on B and record the value for each input level used.

A.4.2.2.3 Output loss distortion with frequency

- a) Connect the IMP and the AP as shown in figure A.8 for 2-wire interfaces and figure A.9 for 4-wire interfaces, where:
- B = level measuring instrument;
- C = digital signal generator;
- D = digital level measuring instrument.
- b) Set C at the AP to provide an input level of -10 dBm₀ as stated for the IUT at a representative series of frequencies in the range specified in this ETS. One of the frequencies used for measurement shall be the reference frequency 1 020 Hz.
- c) Measure the output level at the IMP on B and record the value for each input frequency.

A.4.2.2.4 Output total distortion including quantizing distortion

- a) Connect the IMP and the AP as shown in figure A.8 for 2-wire interfaces and figure A.9 for 4-wire interfaces, where:
- B = level measuring instrument;
- C = digital signal generator;
- D = digital level measuring instrument.

C and B shall form part of the same instrument, which shall be capable of performing total distortion measurements.

- b) Set C at the AP to provide a representative series of input levels in the range specified in this ETS at a frequency of 1 020 Hz.
- c) Measure the output total distortion and record the value for each level used.

A.4.3 Analogue interfaces impedance measurements

A.4.3.1 Return loss

Return loss may be determined by direct impedance measurements and calculation. Alternatively, return loss measuring hybrids as shown in figure A.3 may be used and the following measurement procedures carried out.

- a) Connect the IMP and the AP as shown in figure A.10 for 2-wire interfaces and figure A.11 for 4-wire interfaces, where:
- A = analogue signal generator (sine-wave, low impedance);
- B = level measuring instrument (high input impedance > 20 k Ω);
- C = digital signal generator;
- D = digital level measuring instrument;
- RLH = Return Loss Hybrid.

NOTE: The digital level measuring instrument D is required to enable synchronization of the test apparatus.

- b) Set C to input a quiet code.

- c) Connect the RLH to the IMP and terminate the leads Z_r of RLH with the respective value as stated in the standard for the IUT. Adjust the signal generator A to give an input level of -10 dBm0 at SO at a frequency of 1 020 Hz.
- d) Operate S of RLH to position 2 and adjust the level meter B to give a 0 dB reading.
- e) Operate S of RLH to position 1.
- f) Read off the return losses at the specified frequencies.

Some test instruments are providing the RLH as an integral part with a direct readout of return loss values. In those cases the reference impedance Z_r shall be connected to the respective sockets of the instrument and steps c) to e) are not applicable.

- g) For 4-wire interfaces connect the RLH to the output IMP and Z_r to the input IMP, and repeat steps d) through f).

A.4.3.2 TBRL, stability

The measurement configurations for TBRL and stability are nearly similar. They only differ in the used termination at the IMP. These measurements are only applicable to 2-wire interfaces.

- a) Connect the AP as shown in figure A.12 where:
 - C = digital signal generator;
 - D = digital level measuring instrument.
- b) Terminate the IMP with the nominal test network as specified for this type of interface when performing TBRL measurements. Terminate the IMP with either open or short circuit when performing stability measurements.
- c) Set C at the AP to provide the input level of -10 dBm0 as stated for the IUT at a representative series of frequencies in the range specified in this ETS.
- d) Measure the output levels p_{out} at the AP on D the digital level measuring instrument. Calculate the TBRL using the formula:

$$TBRL = -p_{out} - L_i + L_o - 10 \quad [dB]$$

where L_i and L_o are the nominal relative input and output levels of the IUT.

Calculate the stability loss using the formula:

$$\text{stability loss} = -p_{out} - 10 \quad [dB]$$

- e) Record the result for each input frequency used.

A.4.4 Analogue interfaces, crosstalk

Reference shall be made to "the interfering half connection" (which is defined as that half connection which has the test signal injected) and "the target half connection" (which is defined as the half connection at which the measurement is made).

When considering those interfaces which require to be assessed for crosstalk examination, the physical proximity and geographical relationship between interfaces shall be required. This shall be necessary to limit the number of combinations which are tested to acceptable levels.

To be able to carry out the crosstalk measurements access to two half connections at the same time shall be provided. Thus, if the AP is a single 64 kbit/s co-directional channel as mentioned in subclause A.2.2 (a), two such APs is required; if the AP is a multi-channel system as mentioned in subclause A.2.2 (b) and (c) two channels shall be capable of being used simultaneously.

Each access channel used shall be identified as Access Point Connection 1 (APC 1) and Access Point Connection 2 (APC 2), respectively.

The half connections used in the crosstalk measurements shall be set up to be in the conversational state.

Measurements shall be carried out by use of a frequency selective level measuring instrument.

A.4.4.1 Input connections

A.4.4.1.1 Far End Crosstalk (FEXT)

- a) Having determined the interfaces which are to be used as the interfering half connection and as the target half connection, connect the IMPs and the APs as shown in figure A.13 for 2-wire interfaces, in figure A.14 for 4-wire interfaces and in figure A.15 for measurements between 4-wire and 2-wire interfaces, where:

A_1, A_2 = analogue signal generators (sine-wave);

C_1, C_2 = digital signal generators;

D_1 = digital level measuring instrument.

- b) Set A_1 at the IMP of the target half connection, to provide a low-level activating signal.

NOTE 1: Suitable activating signals are, for example, a band limited noise signal (see CCITT Recommendation O.131 [16]) at a level in the range -50 dBm0 to -60 dBm0 or a sine-wave signal at a level in the range -33 dBm0 to -40 dBm0.

NOTE 2: Care should be taken in the choice of frequency and the filtering characteristics of the measuring apparatus such that the activating signal does not significantly affect the accuracy of the crosstalk measurement.

- c) Set C_1 and C_2 at the APs to input a quiet code (see subclause A.1.8).
- d) Set A_2 at the IMP of the interfering half connection, to provide a sine-wave test signal at the reference frequency of 1 020 Hz at a level of 0 dBm0.
- e) Measure the level of the 1 020 Hz sine-wave in D_1 at the APC 1 of the target half connection, and record the value.

A.4.4.1.2 Near End Crosstalk (NEXT)

- a) Having determined the interfaces which are to be used as the interfering half connection and as the target half connection, connect the IMPs and the APs as shown in figure A.13 for 2-wire interfaces, in figure A.14 for 4-wire interfaces and in figure A.15 for measurements between 4-wire and 2-wire interfaces, where:

A_2 = analogue signal generator (sine-wave);

B_1 = analogue level measuring instrument;

C_1, C_2 = digital signal generators.

- b) Set C_1 and C_2 at the APs, to input a quiet code (see subclause A.1.8).
- c) Set A_2 at the IMP of the interfering half connection, to provide a sine-wave test signal at the reference frequency of 1 020 Hz at a level of 0 dBm0.
- d) Measure the level of the 1 020 Hz sine-wave on B_1 at the IMP of the target half connection, and record the value.

A.4.4.2 Output connections

A.4.4.2.1 Far End Crosstalk (FEXT)

- a) Having determined the interfaces which are to be used as the interfering half connection and as the target half connection, connect the IMPs and the APs as shown in figure A.13 for 2-wire interfaces, in figure A.14 for 4-wire interfaces and in figure A.15 for measurements between 4-wire and 2-wire interfaces, where:

B_1 = analogue level measuring instrument;

C_1, C_2 = digital signal generators.

- b) Set C_1 at the APC 1 to input a quiet code (see subclause A.1.8).
- c) Set C_2 at the APC 2 to provide a digitally simulated sine-wave test signal at the reference frequency 1 020 Hz at a level of 0 dBm0.
- d) Measure the level of the 1 020 Hz sine-wave on B_1 at the IMP of the target half connection, and record the value.

A.4.4.2.2 Near End Crosstalk (NEXT)

- a) Having determined the interfaces which are to be used as the interfering half connection and as the target half connection, connect the IMPs and the APs as shown in figure A.13 for 2-wire interfaces, in figure A.14 for 4-wire interfaces and in figure A.15 for measurements between 4-wire and 2-wire interfaces, where:

A_1 = analogue signal generators (sine-wave);

C_1, C_2 = digital signal generators;

D_1 = digital level measuring instrument.

- b) Set A_1 at the IMP of the target half connection, to provide a low-level activating signal.

NOTE 1: Suitable activating signals are, for example, a band limited noise signal (see CCITT Recommendation O.131 [16]) at a level in the range -50 dBm0 to -60 dBm0 or a sine-wave signal at a level in the range -33 dBm0 to -40 dBm0.

NOTE 2: Care should be taken in the choice of frequency and the filtering characteristics of the measuring apparatus such that the activating signal does not significantly affect the accuracy of the crosstalk measurement.

- c) Set C_1 at the APC 1 to input a quiet code (see subclause A.1.8).
- d) Set C_2 at the APC 2 to provide a digitally simulated sine-wave test signal at the reference frequency 1 020 Hz at a level of 0 dBm0.
- e) Measure the level of the 1 020 Hz sine-wave on D_1 at the APC 1 of the target half connection, and record the value.

A.4.5 Analogue interfaces, noise measurements

A.4.5.1 Weighted noise measurements

The method described here is concerned with the measurement of the total noise at analogue interfaces. The total noise is due to the noise generated by analogue sources, including the PBX power supply, together with noise arising from the encoding / decoding processes. The noise levels due to these sources are influenced by the design and complexity of the interfaces and by the relative levels employed.

PBXs employ a number of different types of interface and the relative levels of a particular interface may vary with the type of connection served. The resultant large number of possible interface connection combinations makes it difficult to carry out noise measurements on complete connections. Half connection measurements are therefore preferred, and in this case, the noise on both the analogue and digital sides of an interface shall be measured.

Measurements are made on the digital side of an interface (i.e. on an input connection) with a digital signal analyser. Analogue measurements on an output connection are made with an analogue signal analyser, which may be a simple psophometer which conforms to the recommendations of CCITT Recommendation P.53 [20]. The digital signal analyser selects a digital signal from any time slot and decodes it. In order to minimize errors the instrument's decoder shall conform to the "ideal" as described in CCITT Recommendation G.711 [11].

The noise measurements are weighted psophometrically and measuring instruments shall incorporate the weighting function as described in ITU-T Recommendation O.41 [15]. Total psophometric power measurements are made and the minimum noise measuring range shall be -80 dBmp to -20 dBmp.

The analogue signal analyser shall have a virtually linear input impedance of 600 Ω as specified in ITU-T Recommendation O.41 [15]. The indicated noise levels are related to the psophometrically weighted noise powers dissipated in this impedance. The noise levels indicated by the digital signal analyser are also related to the psophometrically weighted noise powers dissipated in 600 Ω .

Noise measurements shall be made with the interfaces terminated in impedances which match their output impedances. These impedances are usually complex and hence an impedance converter shall be connected between the terminated interface and the analogue signal analyser. The impedance converter shall present a very high input impedance to the interface and a very low output impedance to the analyser.

A TDU shall be used when interfaces are required to carry line current. The TDU is used to supply this current or, to provide a dc loop, as appropriate for the IUT. Adjustments to the internal components and/or to the TDU's power supply are made to provide the nominal line current before noise measurements are carried out.

A.4.5.1.1 Input connections

- a) Connect the IMP and the AP as shown in figure A.16 for 2-wire interfaces and figure A.17 for 4-wire interfaces, where:

C = digital signal generator;

D = digital signal analyser.

- b) Set C to apply a quiet code (see subclause A.1.8).
c) Measure the weighted noise level on D and record the value.

A.4.5.1.2 Output connections

- a) Connect the IMP and the AP as shown in figure A.18 for 2-wire interfaces and figure A.19 for 4-wire interfaces, where:

B = analogue signal analyser;

C = digital signal generator;

E = termination, appropriate to the type of digital test access interface used.

- b) Set C to apply a quiet code (see subclause A.1.8).
c) Measure the weighted noise level on B and record the value.

The input and output relative levels of a measured interface shall be taken into account when assessing noise performance. Reference shall be made to subclause 5.4 of this ETS to determine the permitted noise levels.

A significant amount of noise may be generated by the TDU, its associated power supply and by the impedance converter. The noise of the test circuit, including these auxiliary equipment, but without IUT shall be < -85 dBmp. When measuring the noise generated by the test circuit, the IUT shall be replaced by a resistor R with the same value as the input dc resistance of the IUT. The resistor R is used to establish the appropriate current in the TDU. The noise correction for the TDU alone may be determined by removing the impedance converter and observing the indicated noise across Z_r with B connected directly to the TDU's output terminals.

A.5 Electro-acoustic measurements

A.5.1 General measurement arrangement

All measurements including a system specific telephony terminal, are performed between the acoustic interface of the telephone handset and the digital test access point of the digital PBX under test. The telephony terminal is connected to its corresponding interface of the PBX and a connection is established between the telephony terminal under test and the test access point. The general test configuration valid for all electro-acoustic measurements in clause A.5 is shown in figure A.20.

All measured values shall, where applicable, be corrected to the nominal values of SLR and RLR as stated by the supplier.

Beside the general issues as given in clauses A.1 to A.3, some additional specifications, described in the following subclauses, shall be considered in conjunction with electro-acoustic measurements.

A.5.1.1 Electro-acoustic test equipment

The test equipment used for electro-acoustic measurements shall conform to ITU-T Recommendation P.64 [23], using the algorithm as described in ITU-T Recommendation P.79 [25].

The artificial mouth shall conform to ITU-T Recommendation P.51 [19].

The artificial ear shall conform to type 1 of the ITU-T Recommendation P.57 [21]. The supplier is permitted to request the use of a type 3.2 artificial ear of ITU-T Recommendation P.57 [21]. In this case the low leakage option of type 3.2 artificial ear shall be adopted. If the geometry of the handset does not allow the use of the type 3.2 artificial ear, then the type 3.3 artificial ear shall be used. The force against the ear shall be as specified in ITU-T Recommendation P.57 [21]. Then the test results shall be corrected to ERP by the correction characteristic specified in ITU-T Recommendation P.57 [21]. When these artificial ears of type 3.2 or 3.3 are used, no leakage correction shall be made in the calculations of RLR, STMR and LSTR (i.e. $L_E = 0$).

A.5.1.2 Accuracy of test equipment

Unless specified otherwise, the accuracy of measurements made by test equipment shall be better than the values given in table A.1.

Table A.1: Accuracy of measurements made by test equipment

Item	Accuracy
Electrical signal power	$\pm 0,2$ dB for levels > -50 dBm
Electrical signal power	$\pm 0,4$ dB for levels < -50 dBm
Sound pressure	$\pm 0,7$ dB
Time	± 5 %
Frequency	$\pm 0,2$ %

Unless specified otherwise, the accuracy of the signals generated by the test equipment shall be better than the values given in table A.2.

Table A.2: Accuracy of signals generated by test equipment

Quantity	Accuracy
Sound pressure level at MRP	± 1 dB for 200 Hz to 4 kHz ± 3 dB for 100 Hz to 200 Hz and 4 kHz to 8 kHz
Electrical excitation levels	$\pm 0,4$ dB (see note 1)
Frequency generation	± 2 % (see note 2)
NOTE 1:	Across the whole frequency range.
NOTE 2:	When measuring sampled systems, it is advisable to avoid measuring at sub-multiples of the sampling frequency. There is a tolerance of ± 2 % on the generated frequencies, which may be used to avoid this problem, except for 4 kHz where only the -2 % tolerance may be used.

A.5.1.3 Ideal codec approach and specification

A.5.1.3.1 Codec approach

As an option, an ideal codec may be used to convert the companded digital input and output bitstream of the test access point to the equivalent analogue values, so that existing test procedures, mainly for electro-acoustic measurements and equipments, without the ability to generate or analyse digital signals, can be used. This codec shall be a high quality codec, whose characteristics are as close as possible to ideal. The specification for such a codec is given below.

A.5.1.3.2 Codec specification

A practical implementation of an ideal codec may be called a reference codec (see clause 4 of ITU-T Recommendation O.133 [18]). For the reference codec, characteristics such as attenuation/frequency distortion, idle channel noise, quantizing distortion, etc., shall be better than the requirements specified in CCITT Recommendation G.712 [12], so as not to mask the corresponding parameters of the set under test. A suitable reference codec may be realized by using:

- at least 14 bit linear A / D and D / A converters of high quality and transcoding the output signal to the A-law PCM format;
- a filter response that meets the requirements of figure A.4.

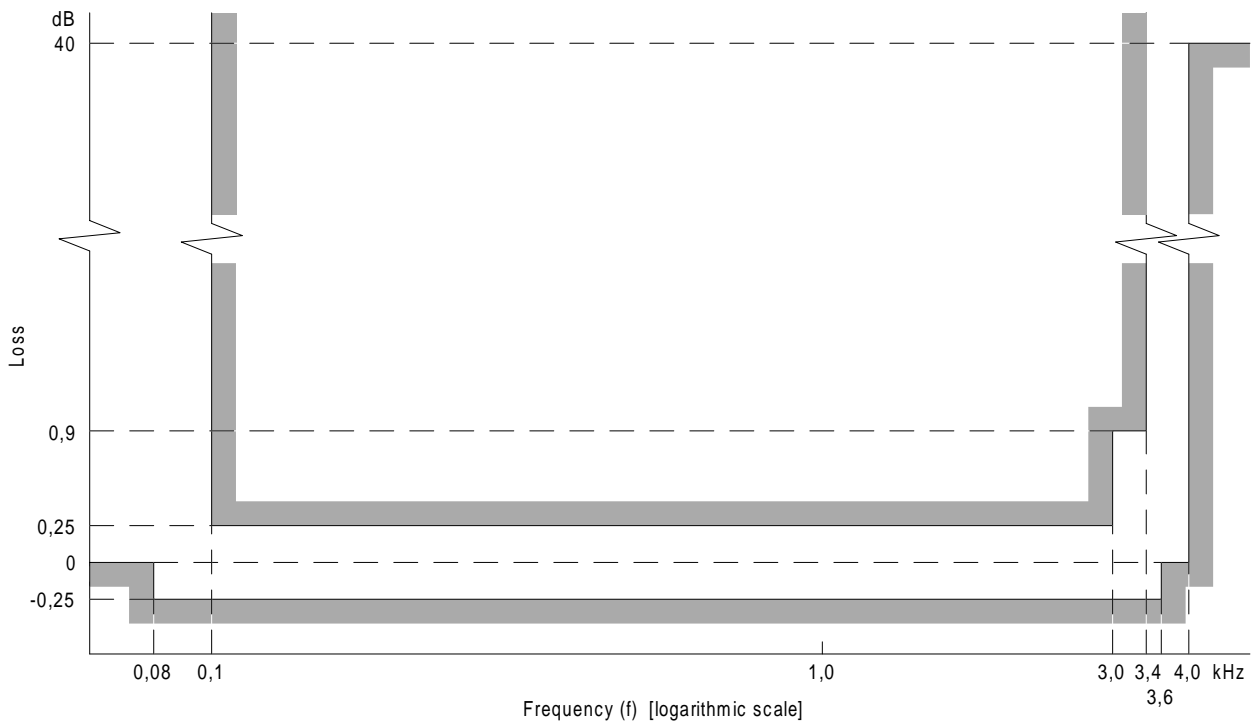

Figure A.4: Attenuation/frequency distortion of the sending or receiving sides of the reference codec

Definition of the analogue 0 dBr point:

D / A converter: a Digital Test Sequence (DTS) representing the PCM equivalent of an analogue sinusoidal signal whose rms value is 3,14 dB (A-law) below the maximum full-load capacity of the codec, shall generate 0 dBm across a 600 Ω load;

A / D converter: a 0 dBm signal generated from a 600 Ω source, shall give the DTS representing the PCM equivalent of an analogue sinusoidal signal, whose rms value is 3,14 dB (A-law) below the maximum full-load capacity of the codec.

DTS is defined as a periodic sequence of character signals as defined in table 5 of CCITT Recommendation G.711 [11].

NOTE: For further information, see figure 6 of ITU-T Recommendation G.101 [3].

Analogue interface: The output and input impedances, return loss and longitudinal conversion losses of the analogue interface of the reference codec shall be in accordance with subclause 3.1.1 of ITU-T Recommendation 0.133 [18].

Digital interface: The fundamental requirements for the reference codec digital interface are given in the appropriate CCITT Recommendations (e.g., CCITT Recommendation G. 703 [10]).

A.5.1.4 Selective measurements

It shall be the responsibility of the test house to select an appropriate bandwidth for selective measurements.

For single frequency noise measurements the procedures of subclauses A.4.5.1.1 and A.4.5.1.2 are followed with the digital and analogue signal analysers in the frequency selective mode. Both in-band and out-of-band single frequency noise components may then be measured.

A.5.1.5 Use of digital loss or gain pads

According to the rules given in clause 4, the use of digital loss or gain pads in the speech path shall be stated by the supplier. If the pads are included in the path between test point of the PBX and system specific telephony terminal, these pads shall be switched inoperative during all transmission measurement, with the exception of:

- SLR (see subclause A.5.2.2.1);
- RLR (see subclause A.5.2.2.2);
- Echo loss (see subclause A.5.2.4);
- Stability loss (see subclause A.5.2.5).

Basically all transmission measurements in conjunction with a system specific telephony terminal, are performed only up to the test point of the PBX. If digital pads are included in the path between test point and the interface KD of the PBX (to be stated by the supplier), test results of SLR, RLR, echo loss and stability loss shall be corrected with the nominal values of the digital loss or gain pads in both transmission directions.

A.5.2 Specific electro-acoustic measurements

A.5.2.1 Sensitivity - frequency response

A.5.2.1.1 Sending

- a) A connection shall be established between the telephony terminal under test and the digital test access point of the PBX.
- b) The handset is mounted in the Loudness Rating Guard ring Position (LRGP) (see ITU-T Recommendation P.64 [23]). The earpiece is sealed to the knife-edge of an artificial ear.
- c) A pure tone signal with a sound level of -4,7 dBPa, in accordance with ITU-T Recommendation P.64 [23] shall be applied at the MRP as described in ITU-T Recommendation P.64 [23], using an artificial mouth conforming to ITU-T Recommendation P.51 [19].
- d) A digital measuring instrument, or high quality digital decoder followed by an analogue level measuring set, shall be connected at the digital test access point of the PBX.
- e) Measurements shall be made at one-twelfth octave intervals as given by the R.40 series of preferred numbers in ISO 3 [31] for frequencies from 100 Hz to 4 kHz inclusive.
- f) At each frequency, the output level for a sound pressure of -4,7 dBPa shall be measured.

A.5.2.1.2 Receiving

- a) A connection is established and the handset is mounted as described in subclause A.5.2.1.1.
- b) A digital signal generator shall be connected at the digital test access point of the PBX, delivering a signal equivalent to a pure tone level of -16 dBm0 (see ITU-T Recommendation P.64 [23]).
- c) Measurements shall be made at one twelfth-octave intervals as given by the R.40 series of preferred numbers in ISO 3 [31] for frequencies from 100 Hz to 4 kHz inclusive.
- d) At each frequency, the sound pressure in the artificial ear shall be measured by connecting a suitable measuring set to the artificial ear.

A.5.2.2 Loudness Ratings (LR)

A.5.2.2.1 Sending Loudness Rating (SLR)

- a) The connection is established and the handset is mounted as described in subclause A.5.2.1.1. The sending sensitivity shall be measured at each of the 14 frequencies given in table 1, bands 4 to 17 of ITU-T Recommendation P.79 [25].
- b) The sensitivity is expressed in terms of dBV/Pa and the SLR shall be calculated according to formula 2.1, over bands 4 to 17 of ITU-T Recommendation P.79 [25] using $m = 0,175$ and the sending weighting factors from table 1 of ITU-T Recommendation P.79 [25].

NOTE: ITU-T Recommendation P.64 [23] allows the use of alternative signal sources for measurement of LRs. If such a signal source is used, it is the responsibility of the test house to ensure that the method used is equivalent to that described above.

A.5.2.2.2 Receiving Loudness Rating (RLR)

- a) A connection is established and the handset is mounted as described in subclause A.5.2.1.1. The receiving sensitivity shall be measured at each of the 14 frequencies listed in table 1, bands 4 to 17, of ITU-T Recommendation P.79 [25].
- b) The sensitivity is expressed in terms of dBPa/V and the RLR shall be calculated according to formula 2.1, over bands 4 to 17 of ITU-T Recommendation P.79 [25], using $m = 0,175$ and the receiving weighting factors from table 1 of ITU-T Recommendation P.79 [25].
- c) The artificial ear sensitivity shall be corrected using the leakage correction of table 2 of ITU-T Recommendation P.79 [25].

NOTE: ITU-T Recommendation P.64 [23] allows the use of alternative signal sources for measurement of LRs. If such a signal source is used, it is the responsibility of the test house to ensure that the method used is equivalent to that described above.

A.5.2.3 Sidetone

For the tests described in subclauses A.5.2.3.1 and A.5.2.3.2, the digital input of the test access point shall be driven by a PCM signal corresponding to decoder value number 1.

A.5.2.3.1 Talker's sidetone

- a) A connection is established and the handset is mounted as described in subclause A.5.2.1.1. A pure tone signal of $-4,7$ dBPa shall be applied at the MRP. For each frequency given in table 3, bands 1 to 20 of ITU-T Recommendation P.79 [25], the sound pressure in the artificial ear shall be measured.
- b) Where a user controlled volume control is provided, the measurements shall be carried out at a setting, which is as close as possible to the declared nominal value of the RLR.
- c) The Sidetone path loss (L_{meST}), expressed in dB, and the STMR, also expressed in dB, shall be calculated from the formula 2.1 of ITU-T Recommendation P.79 [25], using $m = 0,225$ and the weighting factors of table 3 of ITU-T Recommendation P.79 [25].

NOTE: ITU-T Recommendation P.65 [24] allows the use of alternative signal sources for measurement of LRs. If such a signal source is used, it is the responsibility of the test house to ensure that the method used is equivalent to that described above.

A.5.2.3.2 Listener's sidetone

- a) The diffuse sound field is calibrated in the absence of any local obstacles. The averaged field shall be uniform to within ± 3 dB within a radius of 0,15 m of the MRP, when measured in one-third octave bands according to IEC 225 [29] from 100 Hz to 8 kHz (bands 1 to 20).

NOTE 1: The pressure intensity index, as defined in ISO/DIS 9614-1 [32], may prove to be a suitable method for assessing the diffuse field.

NOTE 2: Where more than one loudspeaker is used to produce the desired sound field, the loudspeakers may require to be fed with non coherent electrical signals to eliminate standing waves and other interference effects.

- b) For measurement of LSTR a connection is established and the handset is mounted as described in subclause A.5.2.1.1.
- c) Where a user controlled volume control is provided, the measurements shall be carried out at a setting which is as close as possible to the declared nominal value of the RLR.
- d) Where adaptive techniques or voice switching circuits are not used (need to be declared by the supplier), the spectrum of the diffuse sound field shall be a band limited "pink noise" (50 Hz to 10 kHz) according to annex B of CCITT Recommendation P.64 [22], to within ± 3 dB and the level shall be adjusted to 70 dB(A) (-24 dBPa(A)). The tolerance for this level adjustment is ± 1 dB. In other cases the level shall be adjusted to 50 dB(A) (-44 dBPa(A)), with a tolerance of ± 1 dB.
- e) Measurements shall be made on one-third octave bands according to IEC 225 [29] for the 20 bands centred at 100 Hz to 8 kHz (bands 1 to 20). For each band the sound pressure in the artificial ear shall be measured by connecting a suitable measuring set to the artificial ear.

NOTE 3: There may be problems with the signal to noise ratio. If it is less than 10 dB in any band, the microphone noise level and the noise level of any out-of-band signals need to be subtracted from the measured sidetone level (power subtraction).

- f) The listener sidetone path loss is expressed in dB and the LSTR shall be calculated from formula 2.1 of ITU-T Recommendation P.79 [25], using $m = 0,225$ and the weighting factors in table 3 of ITU-T Recommendation P.79 [25].
- g) For the weighted average D of the difference of the send sensitivities between diffuse and direct sound the diffuse sound sensitivities measured as specified above shall be used for the calculation as $S_{si}(\text{diff})$ at 14 bands from 200 Hz to 4 kHz. The sending sensitivities for the direct sound $S_{si}(\text{direct})$ shall be measured according to subclause A.5.2.1.1, but at one-third octave bands for 14 bands centred at 200 Hz to 4 kHz with the pink noise test signal as specified above. D is computed with $S_{si}(\text{diff})$ and $S_{si}(\text{direct})$ from the ITU-T Recommendation P.79 [25] formulas E-2 and E-3 and the coefficients K_i in table E.1/P.79.

A.5.2.4 Echo loss

- a) A connection is established between the system specific telephony terminal and the test access point.
- b) The handset is suspended in free air in such a way, that the inherent mechanical coupling of the handset is not effected. The testing shall be made under free field condition (the deviation from ideal free field conditions shall be less than 1 dB). The ambient noise level shall be less than 30 dB(A).
- c) The attenuation from digital input to digital output of the test access point shall be measured, using a pure tone at one-twelfth octave intervals as given in the R.40 series of preferred numbers in ISO 3 [31] for frequencies from 300 Hz to 3 350 Hz. The input signal shall be -10 dBm0. The echo loss is calculated according to clause B.4 of ITU-T Recommendation G.122 [6] (trapezoidal rule).

A.5.2.5 Stability loss

The measurement of stability loss is performed independent, if the system specific telephony terminal is an analogue or digital telephony terminal, connected to its appropriate interface of the PBX.

- a) A connection is established between the system specific telephony terminal and the test access point.

- b) The handset, with the transmission circuit fully active, shall be positioned on one inside surface that is of three perpendicular plane, smooth, hard surfaces forming a corner. Each surface shall extend 0,5 m from the apex of the corner. One surface shall be marked with a diagonal line, extending from the corner formed by the three surfaces and a reference position 250 mm from the corner, as shown in figure A.5:

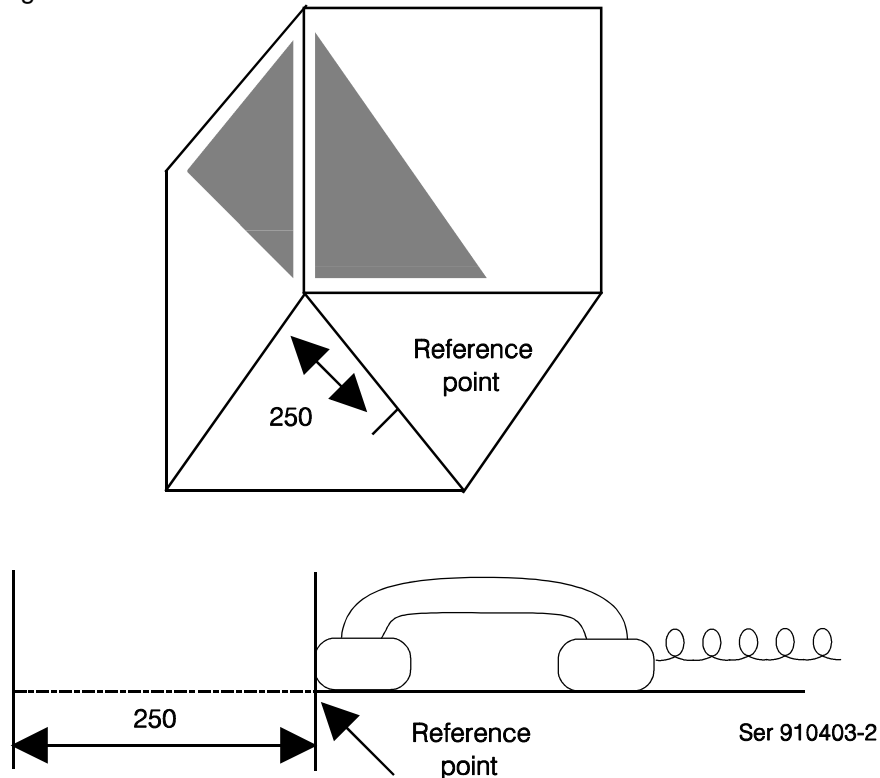

Figure A.5: Position of handset for stability measurements

- c) With an input signal of -10 dBm₀, the attenuation from digital input to digital output of the test access point shall be measured, using a pure tone at one-twelfth octave intervals for frequencies from 200 Hz to 3 600 Hz under the following conditions:
- the handset, with the transmission circuit fully active, shall be positioned on the defined surface as follows:
 - 1) the mouthpiece and earcap shall face towards the surface;
 - 2) the handset shall be placed centrally, the diagonal line with the earcap nearer to the apex of the corner;
 - 3) the extremity of the handset shall coincide with the normal to the reference point, as shown in figure A.5.

A.5.2.6 Distortion

A.5.2.6.1 Sending

A.5.2.6.1.1 Method 1

- a) A connection is established between the system specific telephony terminal and the test access point of the PBX. The handset is mounted at the LRGP and the earpiece is sealed to the knife-edge of the artificial ear.
- b) A band-limited noise signal corresponding to CCITT Recommendation O.131 [16], shall be applied at the MRP. The level of this signal is adjusted until the output at the test access point is -10 dBm₀. The level of the signal at the MRP in dBPa is then the ARL.

- c) The test signal shall be applied at the following levels relative to ARL:
-45 dB, -40 dB, -35 dB, -30 dB, -24 dB, -20 dB, -17 dB, -10 dB, -5 dB, 0 dB, 4 dB, 7 dB.
- d) The ratio of signal to total distortion power of the digital signal output shall be measured (see annex A of CCITT Recommendations G.712 [12] and O.131 [16]).

A.5.2.6.1.2 Method 2

- a) A connection is established and the handset is mounted as described in subclause A.5.2.6.1.1.
- b) A sine-wave signal with a frequency in the range 1 004 Hz to 1 025 Hz shall be applied at the MRP. The level of this signal is adjusted until the output of the test access point is -10 dBm₀. The level of the signal at the MRP in dBPa is then the ARL.
- c) The test signal shall be applied at the following levels relative to ARL:
-35 dB, -30 dB, -25 dB, -20 dB, -15 dB, -10 dB, -5 dB, 0 dB, 7 dB, 10 dB.
- d) The ratio of the signal to total distortion power of the digital signal output shall be measured with the psophometric noise weighting (see CCITT Recommendations G.712 [12] and O.132 [17]).

A.5.2.6.2 Receiving

A.5.2.6.2.1 Method 1

- a) A connection is established and the handset is mounted as described in subclause A.5.2.6.1.1.
- b) A digitally simulated band-limited noise signal corresponding to CCITT Recommendation O.131 [16] shall be applied at the input of the test access point at the following levels:
-55 dBm₀, -50 dBm₀, -45 dBm₀, -40 dBm₀, -34 dBm₀, -30 dBm₀, -27 dBm₀, -20 dBm₀;
-15 dBm₀, -10 dBm₀, -6 dBm₀, -3 dBm₀.
- c) The ratio of signal to total distortion power shall be measured in the artificial ear (see annex A of CCITT Recommendations G.712 [12] and O.131 [16]).

A.5.2.6.2.2 Method 2

- a) A connection is established and the handset is mounted as described in subclause A.5.2.6.1.1.
- b) A digitally simulated sine-wave signal with a frequency in the range 1 004 Hz to 1 025 Hz shall be applied at the input of the test access point at the following levels:
-45 dBm₀, -40 dBm₀, -35 dBm₀, -30 dBm₀, -25 dBm₀, -20 dBm₀, -15 dBm₀, -10 dBm₀, -3 dBm₀, 0 dBm₀.
- c) The ratio of the signal-to-total distortion power shall be measured with the psophometric noise weighting in the artificial ear (see CCITT Recommendations G.712 [12] and O.132 [17]).

A.5.2.6.3 Sidetone

- a) A connection is established and the handset is mounted as described in subclause A.5.2.6.1.1.
- b) An instrument capable of measuring the third harmonic distortion of signals with fundamental frequencies in the range of 315 Hz to 1 kHz shall be connected to the artificial ear.
- c) The digital input of the test access point shall be driven by a PCM signal, corresponding to decoder value number 1.
- d) A pure-tone signal of -4,7 dBPa shall be applied at the MRP at frequencies of 315 Hz, 500 Hz and 1 kHz. For each frequency, the third harmonic distortion shall be measured in the artificial ear.

A.5.2.7 Variation of gain with input level

A.5.2.7.1 Sending

- a) A connection is established and the handset is mounted as described in subclause A.5.2.6.1.1.
- b) A sine-wave signal with a frequency in the range 1 004 Hz to 1 025 Hz shall be applied at the MRP. The level of this signal is adjusted, until the output at the test access point is -10 dBm₀. The level of the signal at the MRP in dBPa is then the ARL.
- c) The test signal shall be applied at the following levels relative to ARL:
-45 dB, -40 dB, -35 dB, -30 dB, -25 dB, -20 dB, -15 dB, -10 dB, -5 dB, 0 dB, 4 dB, 10 dB, 13 dB.
- d) The variation of gain relative to the gain for the ARL shall be measured.

NOTE: Selective measurement may be used to avoid the effects of ambient noise.

A.5.2.7.2 Receiving

- a) A connection is established and the handset is mounted as described in subclause A.5.2.6.1.1.
- b) A digitally simulated sine-wave signal with a frequency in the range 1 004 Hz to 1 025 Hz shall be applied at the digital interface at the following levels:
-50 dBm₀, -45 dBm₀, -40 dBm₀, -35 dBm₀, -30 dBm₀, -25 dBm₀, -20 dBm₀, -15 dBm₀, -10 dBm₀, -6 dBm₀, 0 dBm₀, 3 dBm₀.
- c) The variation of gain relative to the gain at an input level of -10 dBm₀ shall be measured in the artificial ear.

NOTE: Selective measurement may be used to avoid the effects of ambient noise.

A.5.2.8 Out-of-band signals

A.5.2.8.1 Discrimination against out-of-band input signal

- a) A connection is established and the handset is mounted as described in subclause A.5.2.6.1.1.
- b) Input signals at frequencies of 4,65 kHz, 5 kHz, 6 kHz, 6,5 kHz, 7 kHz and 7,5 kHz are applied at the MRP with a level of -4,7 dBPa.
- c) The level of any inband image frequency at the output of the test access point shall be measured selectively.

A.5.2.8.2 Spurious out-of-band signals

- a) A connection is established and the handset is mounted as described in subclause A.5.2.6.1.1.
- b) Input signals at the frequencies 500 Hz, 1 000 Hz, 2 000 Hz, and 3 150 Hz are applied at the input of the test access point with a level of -10 dBm₀.
- c) The level of spurious out-of-band image signals at frequencies of up to 8 kHz shall be measured selectively in the artificial ear.

A.5.2.9 Noise

A.5.2.9.1 Sending

- a) A connection between the system specific telephony terminal and the test access point is established and the handset mounted at the LRGP with the earpiece sealed to the knife-edge of the artificial ear in a quiet environment (ambient noise less than 30 dBA).

- b) The noise level at the output of the test access point shall be measured with apparatus including psophometric weighting according to table 4 of CCITT Recommendation G.223 [9].

A.5.2.9.2 Receiving

- a) A connection is established and the handset is mounted as described in subclause A.5.2.9.1. The ambient noise shall not exceed 30 dBA.
- b) A signal corresponding to decoder output value number 1 shall be applied at the input of the test access point.
- c) Where a user controlled volume control is provided, the measurements shall be carried out at a setting, which is as close as possible to the declared nominal value of the RLR.
- d) The level of the noise shall be measured in the artificial ear.

A.5.2.9.3 Level of sampling frequency (receiving)

Under the same conditions as specified in subclause A.5.2.9.2, the level at 8 kHz in the artificial ear shall be measured selectively.

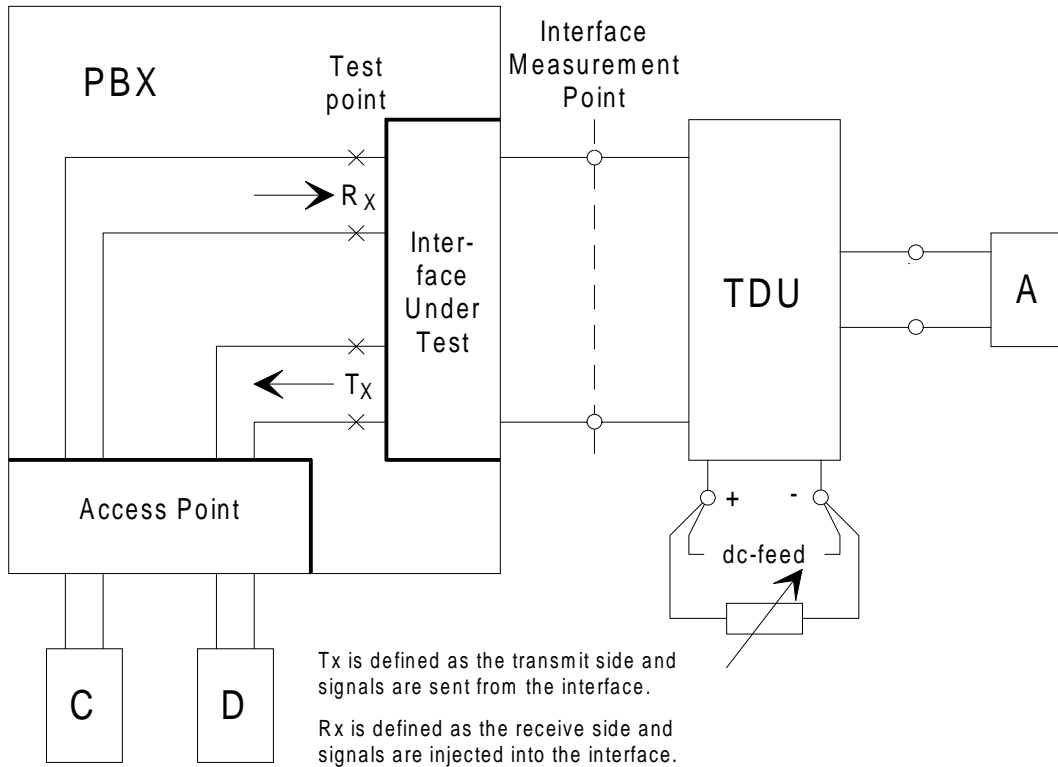

Figure A.6: 2-wire analogue interface, input connection

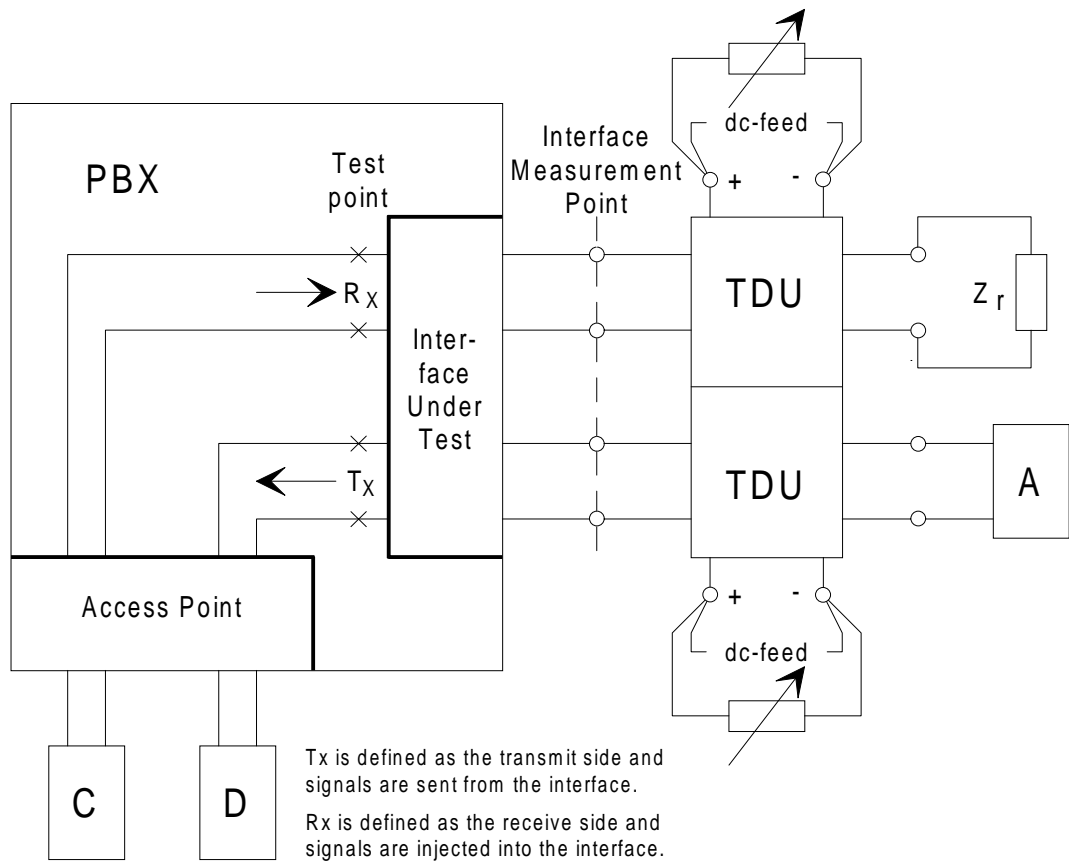

Figure A.7: 4-wire analogue interface, input connection

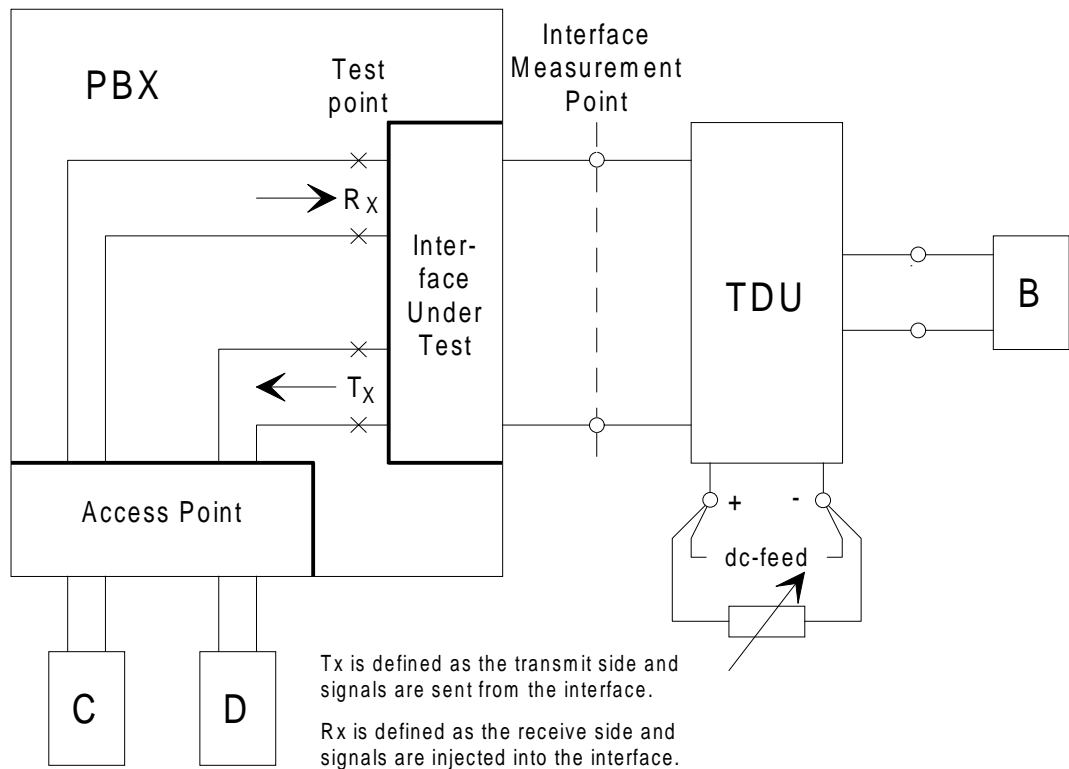

Figure A.8: 2-wire analogue interface, output connection

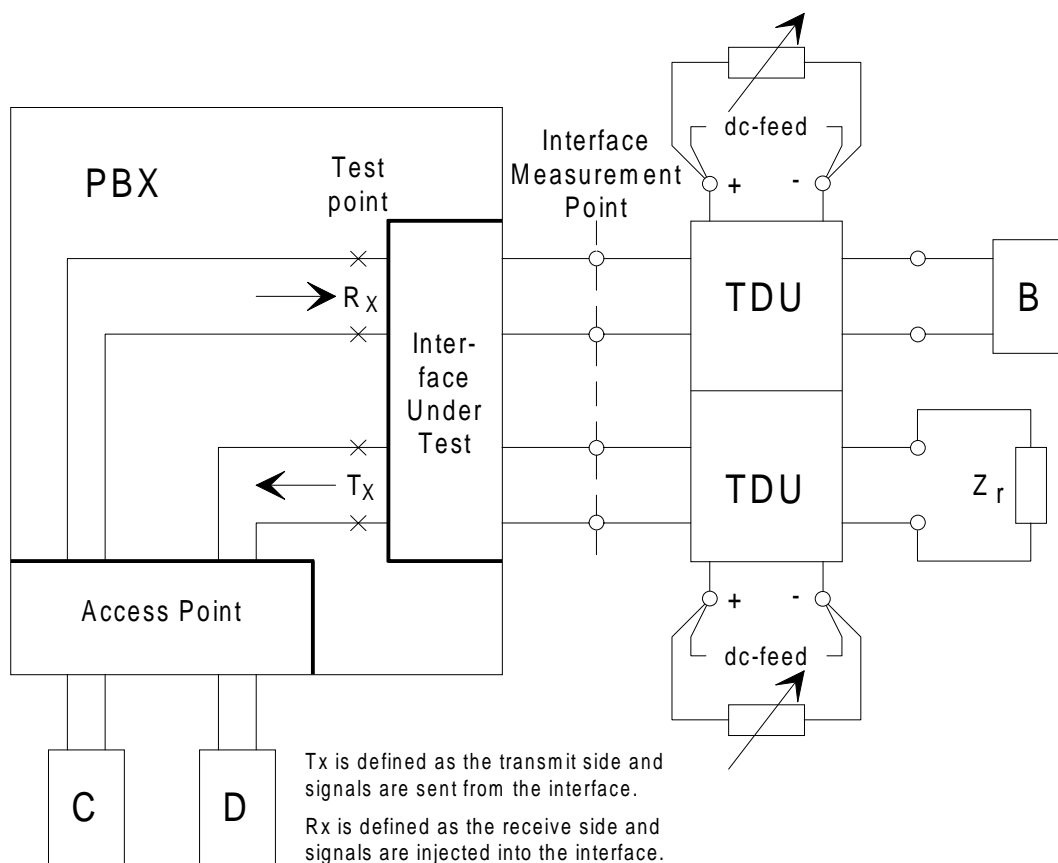

Figure A.9: 4-wire analogue interface, output connection

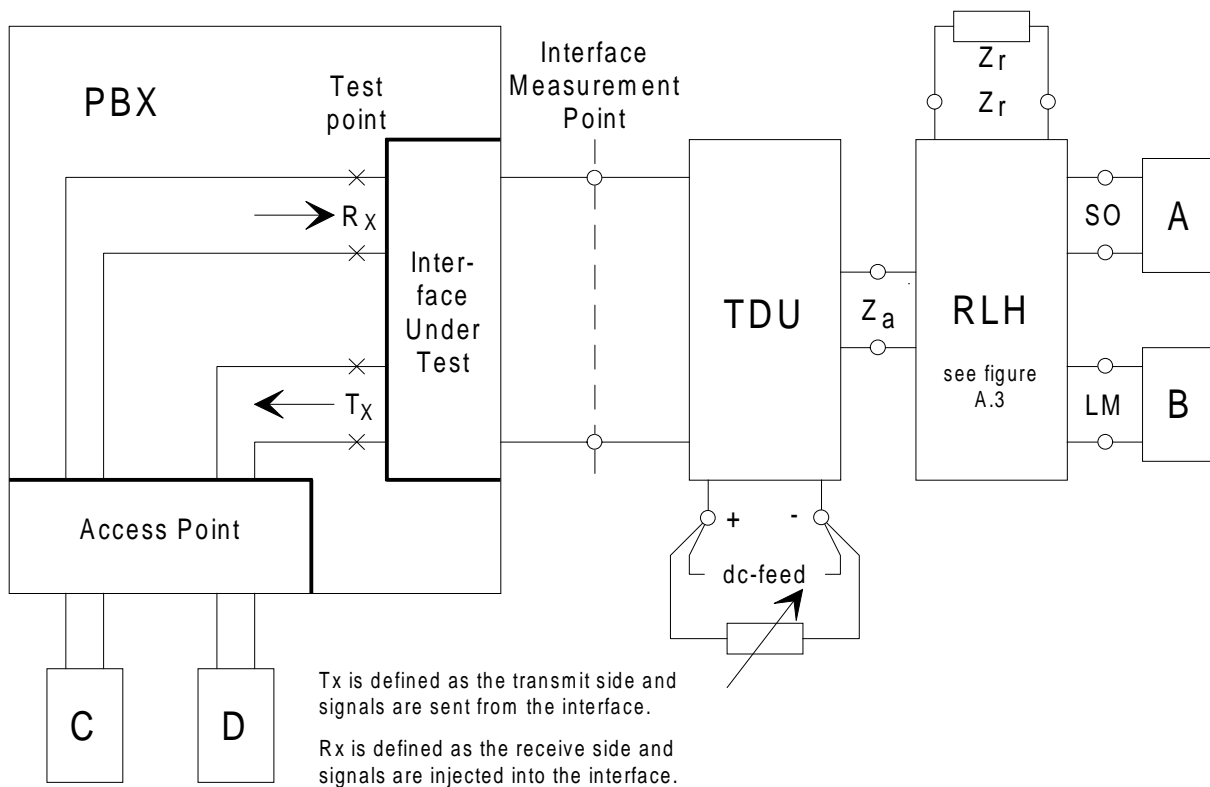

Figure A.10: 2-wire analogue interface, return loss

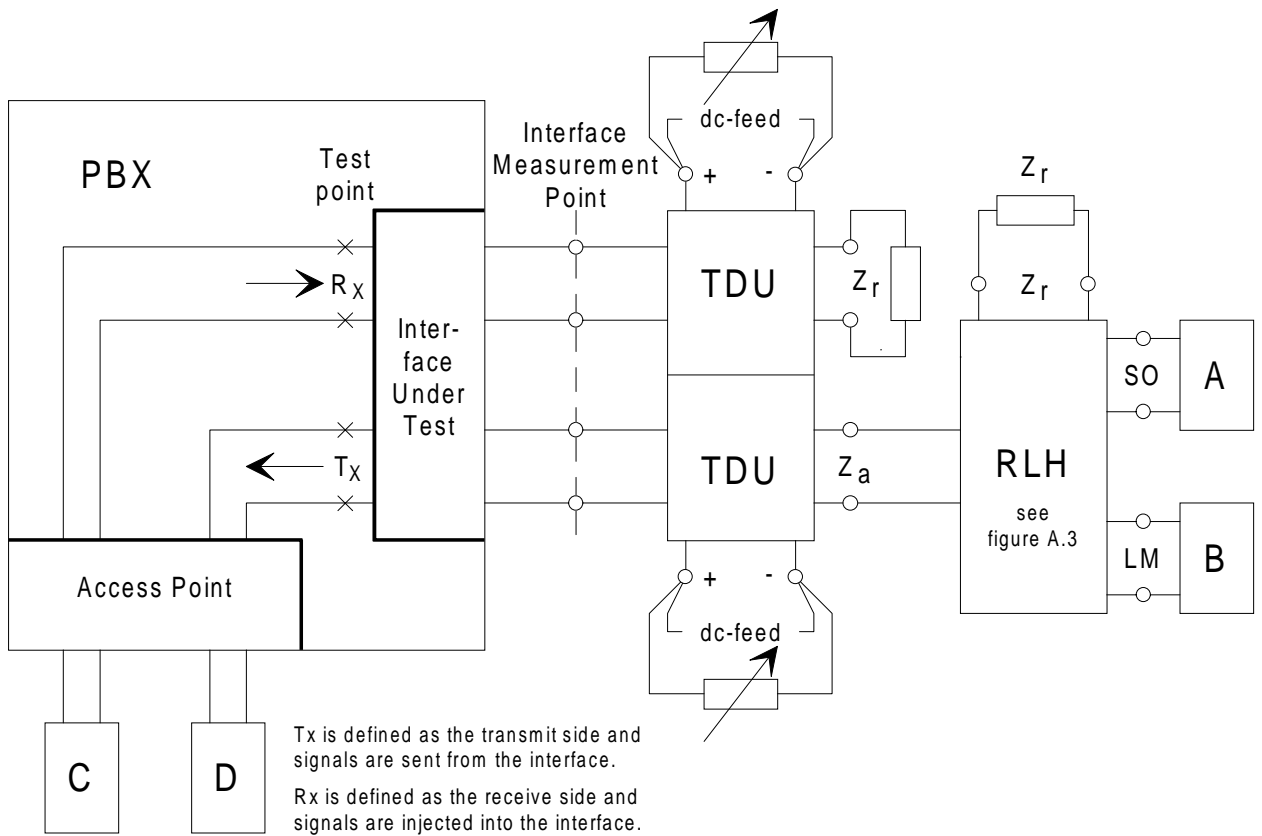

Figure A.11: 4-wire analogue interface, return loss (shown only for the transmit side)

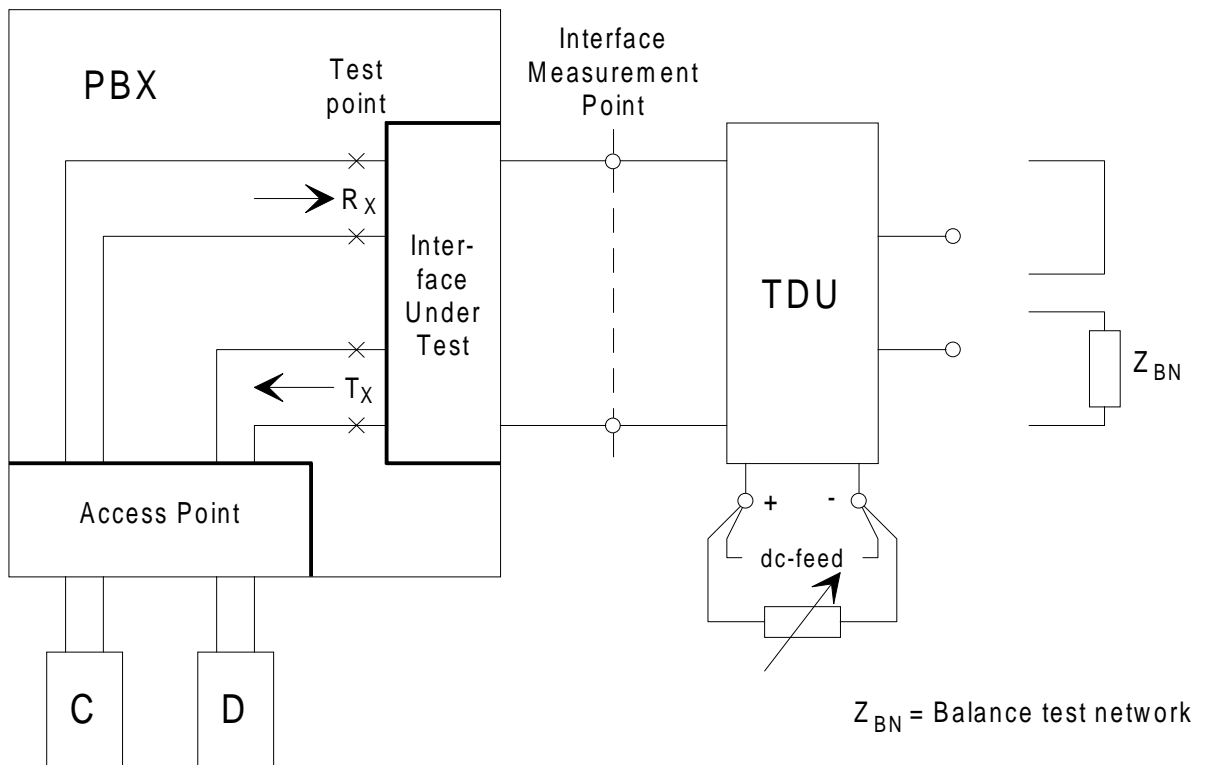
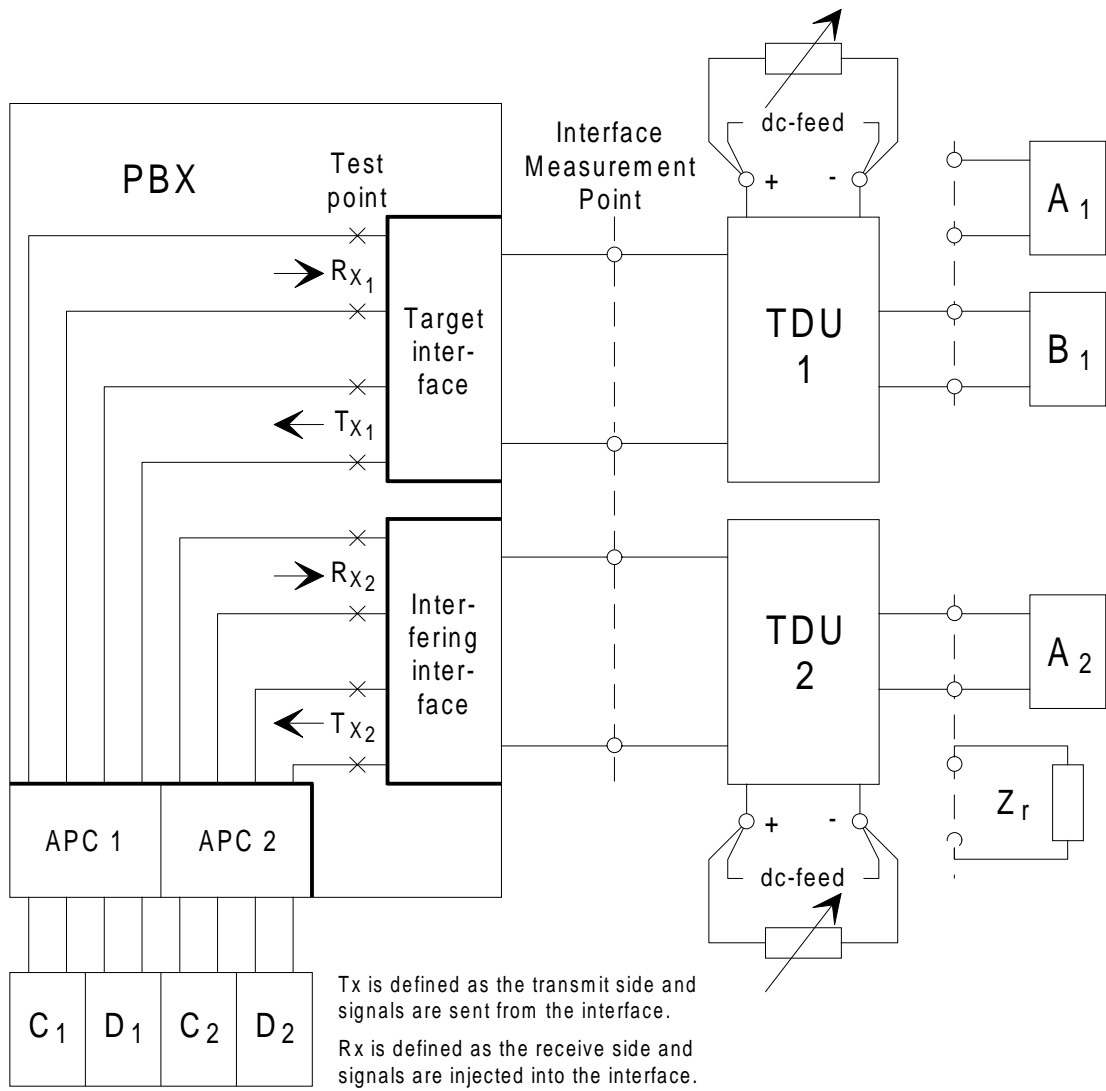
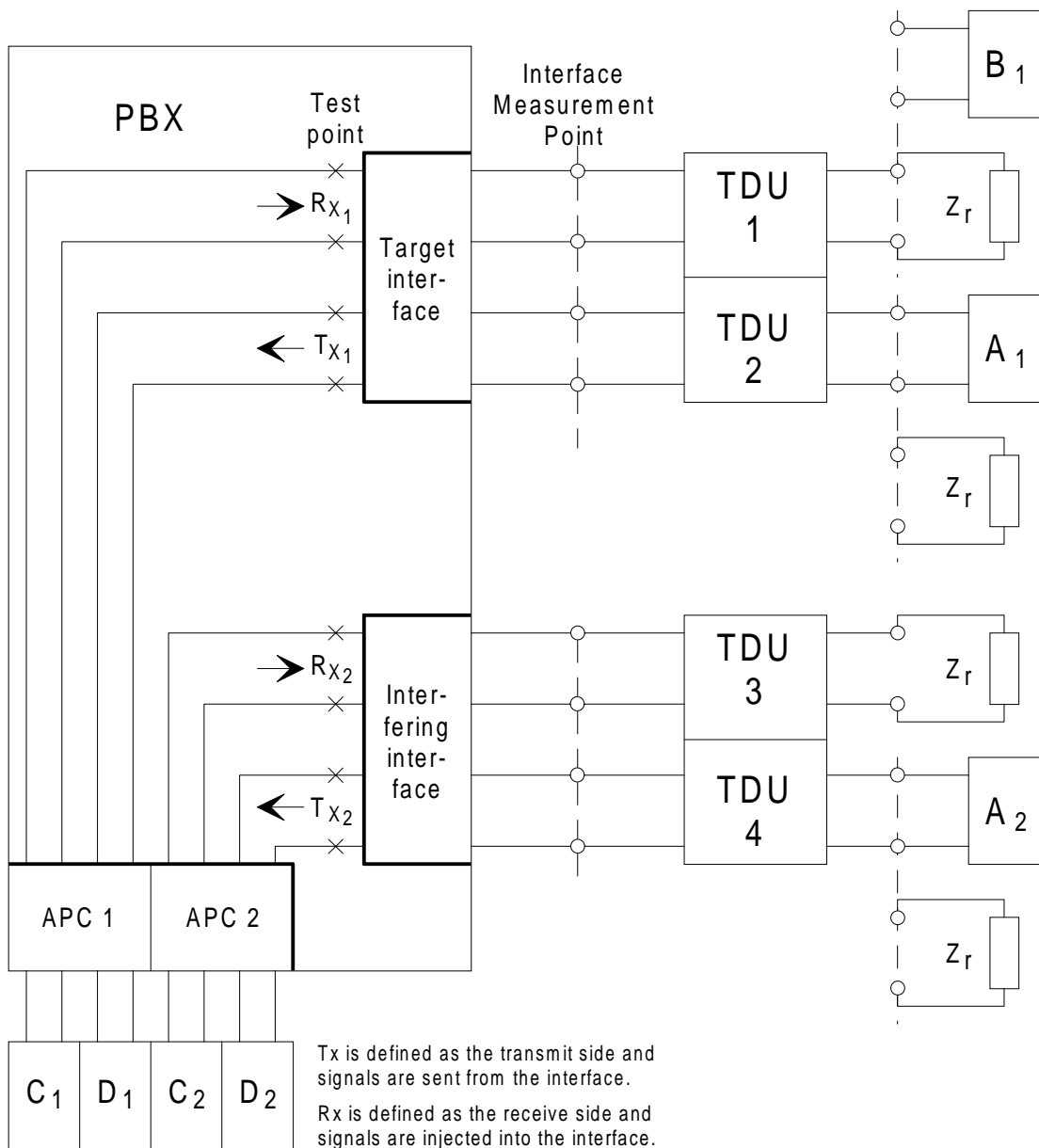

Figure A.12: Terminal Balance Return Loss, stability



Case No.	Connection	NEXT/FEXT	TDU 1	TDU 2	C ₁	C ₂	D ₁	D ₂
1	Input	FEXT	A ₁ Activating	A ₂ Sending	Quiet Code	Quiet Code	Measuring	
2	Input	NEXT	B ₁ Measuring	A ₂ Sending	Quiet Code	Quiet Code		
3	Output	FEXT	B ₁ Measuring	Z _r	Quiet Code	Sending		
4	Output	NEXT	A ₁ Activating	Z _r	Quiet Code	Sending	Measuring	

Figure A.13: Crosstalk measurements on 2-wire analogue interfaces



Case No.	Conne- ction	NEXT/ FEXT	TDU 1	TDU 2	TDU 3	TDU 4	C ₁	C ₂	D ₁	D ₂
1	Input	FEXT	Z _r	A ₁ Activating	Z _r	A ₂ Sending	Quiet Code	Quiet Code	Measuring	
2	Input	NEXT	B ₁ Measuring	Z _r	Z _r	A ₂ Sending	Quiet Code	Quiet Code		
3	Output	FEXT	B ₁ Measuring	Z _r	Z _r	Z _r	Quiet Code	Sending		
4	Output	NEXT	Z _r	A ₁ Activating	Z _r	Z _r	Quiet Code	Sending	Measuring	

Figure A.14: Crosstalk measurements on 4-wire analogue interfaces

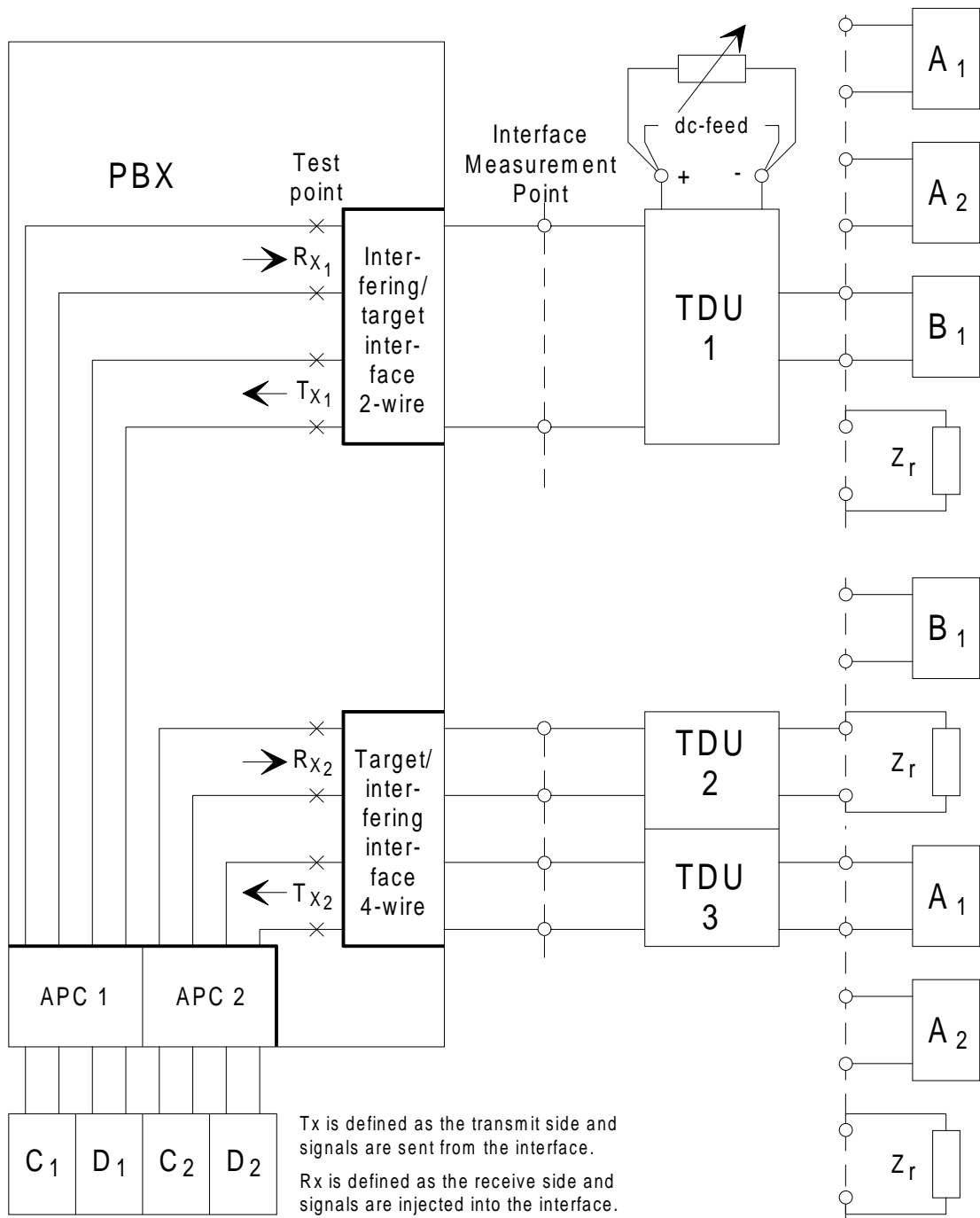

Interfering interface: 2-wire

Target interface: 4-wire

Case No.	Connection	NEXT/FEXT	TDU 1	TDU 2	TDU 3	C ₁	C ₂	D ₁	D ₂
1	Input	FEXT	A ₂ Sending	Z _r	A ₁ Activating	Quiet Code	Quiet Code		Measuring
2	Input	NEXT	A ₂ Sending	B ₁ Measuring	Z _r	Quiet Code	Quiet Code		
3	Output	FEXT	Z _r	B ₁ Measuring	Z _r	Sending	Quiet Code		
4	Output	NEXT	Z _r	Z _r	A ₁ Activating	Sending	Quiet Code		Measuring

Interfering interface: 4-wire			Target interface: 2-wire						
Case No.	Connection	NEXT/FEXT	TDU 1	TDU 2	TDU 3	C ₁	C ₂	D ₁	D ₂
1	Input	FEXT	A ₁ Activating	Z _r	A ₂ Sending	Quiet Code	Quiet Code	Measuring	
2	Input	NEXT	B ₁ Measuring	Z _r	A ₂ Sending	Quiet Code	Quiet Code		
3	Output	FEXT	B ₁ Measuring	Z _r	Z _r	Quiet Code	Sending		
4	Output	NEXT	A ₁ Activating	Z _r	Z _r	Quiet Code	Sending	Measuring	

Figure A.15: Crosstalk measurements between 4-wire and 2-wire analogue interfaces

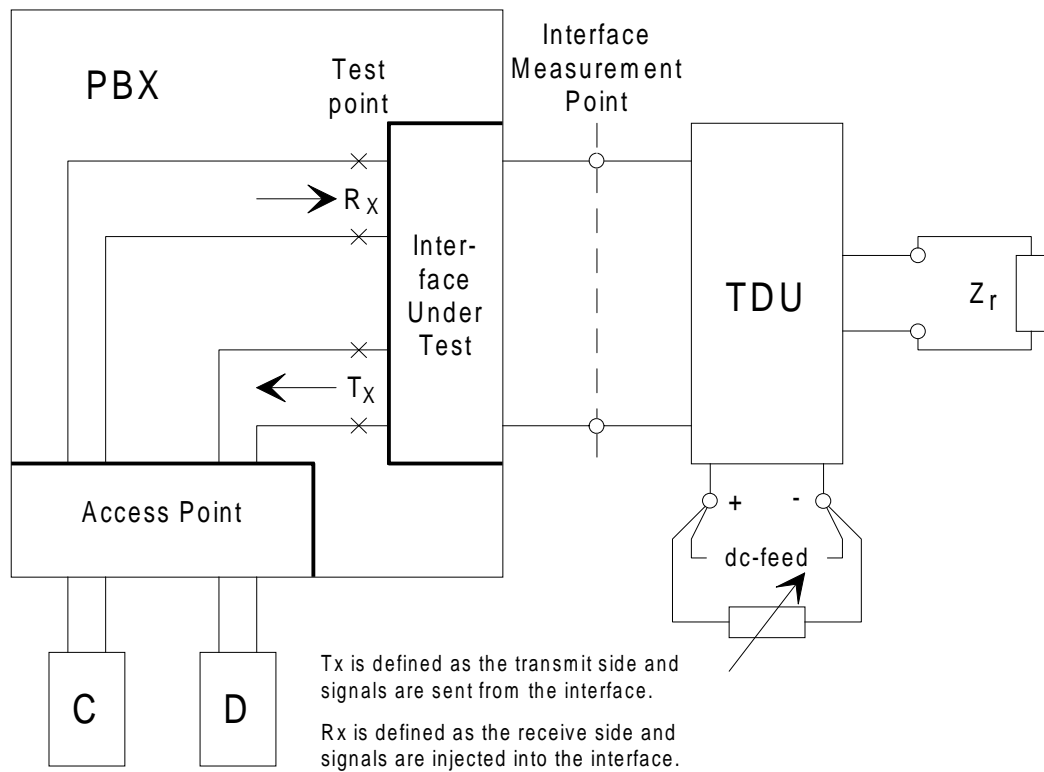

Figure A.16: 2-wire analogue interface, input connection noise measurement

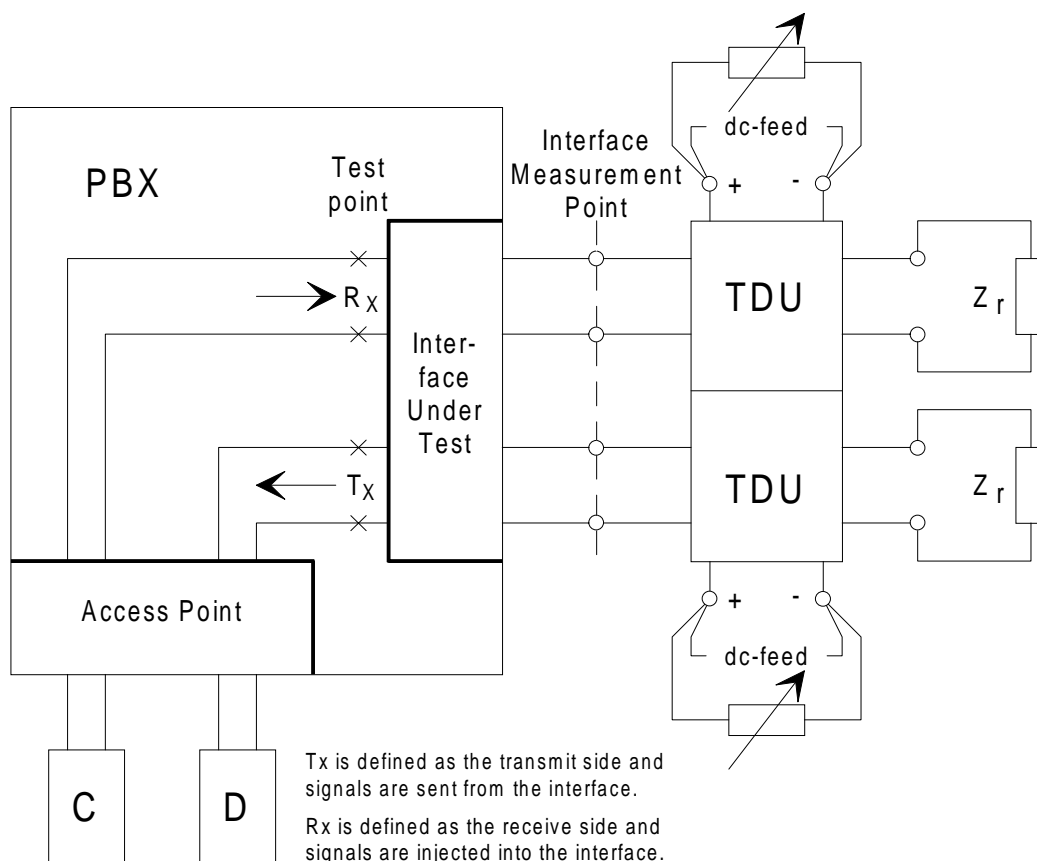

Figure A.17: 4-wire analogue interface, input connection noise measurement

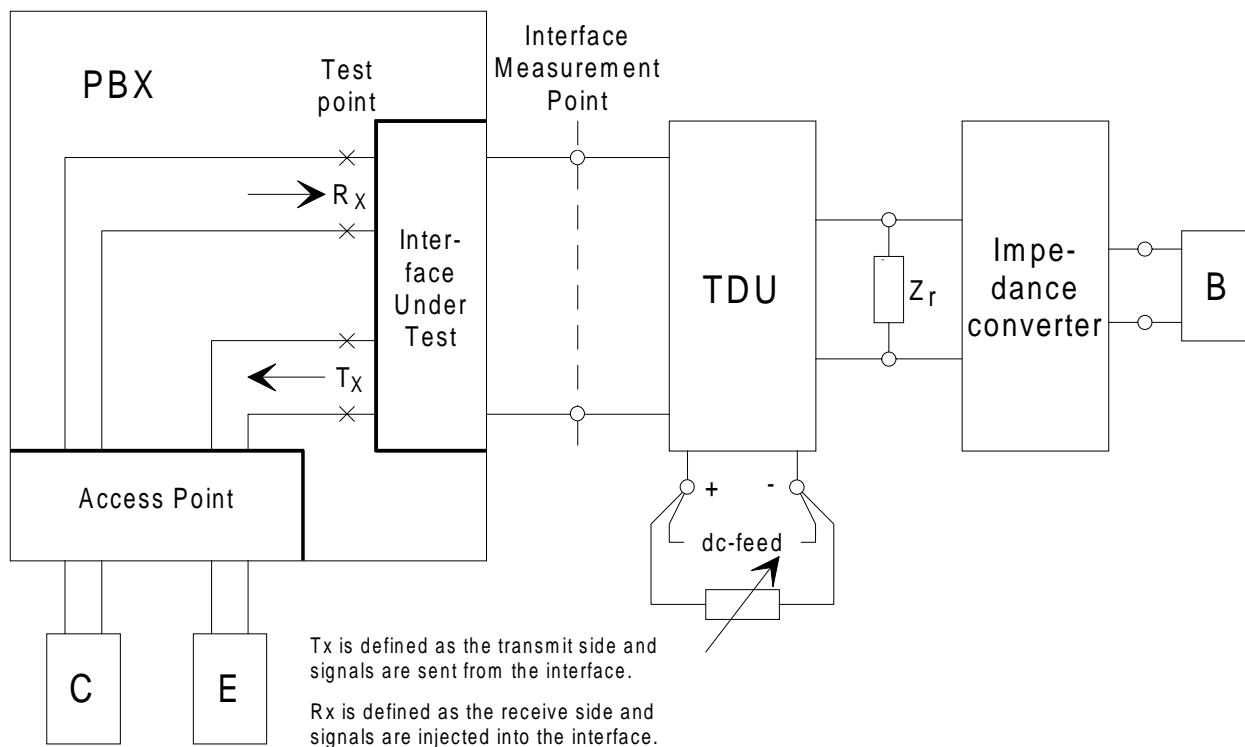

Figure A.18: 2-wire analogue interface, output connection noise measurement

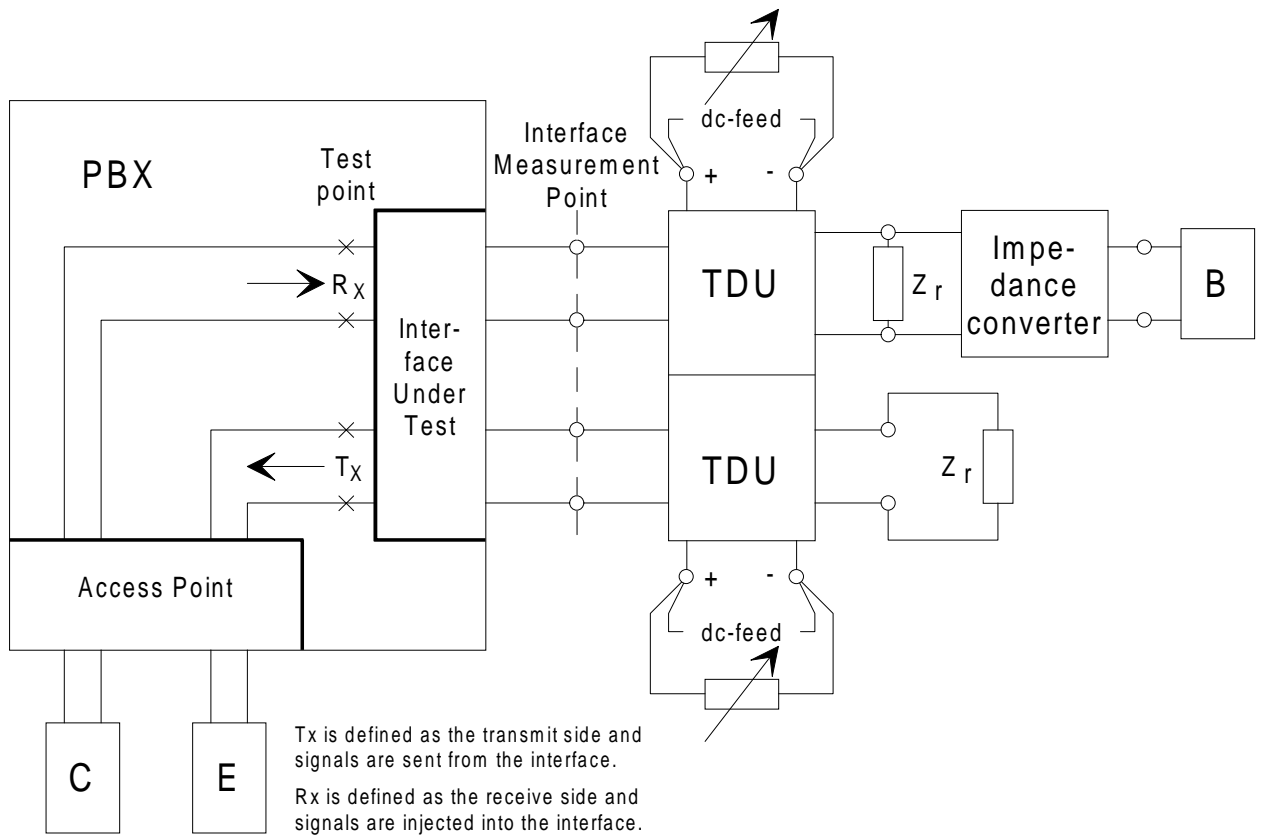

Figure A.19: 4-wire analogue interface, output connection noise measurement

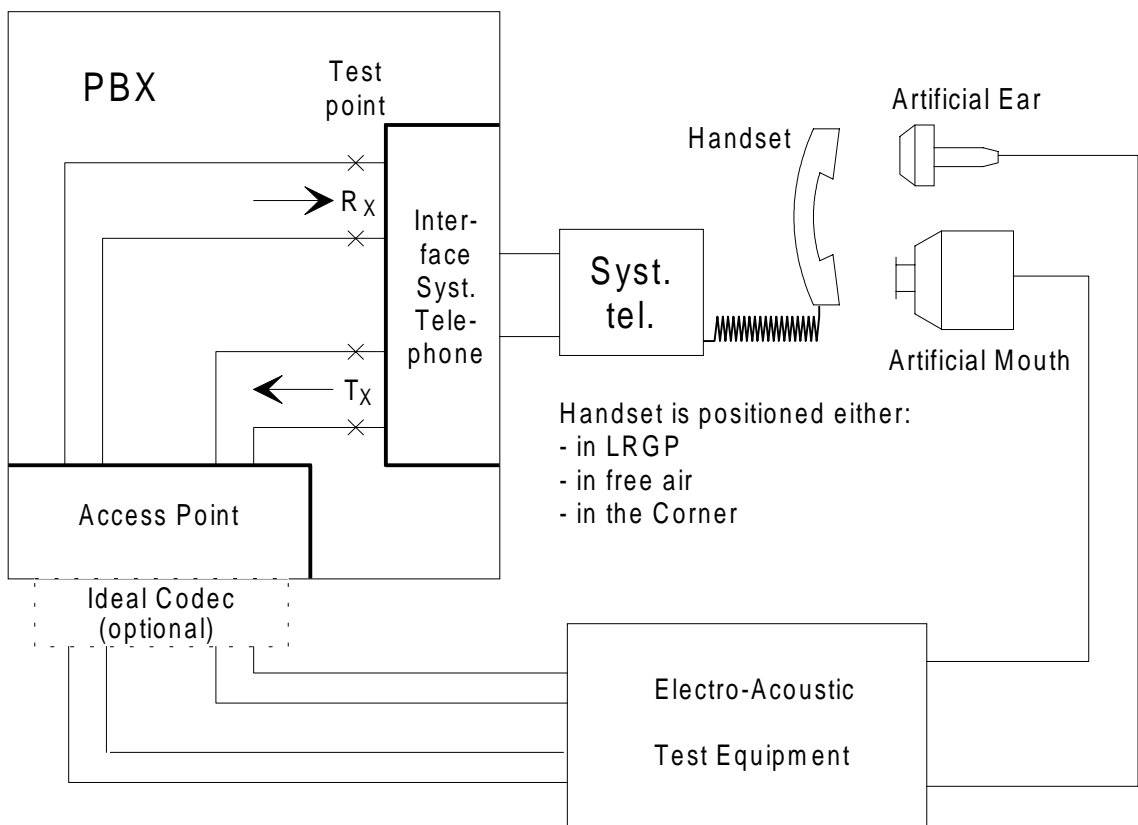

Figure A.20: Test configuration for electro-acoustic measurements

Annex B (informative): General considerations for the choice of test instrumentation

B.1 Overall measuring accuracy

As a general objective, the accuracy of the test equipment should be an order of magnitude better than the relevant performance limits of the PBX under test.

In some cases it may not be possible to meet this objective due to technical and cost limitations.

NOTE: For proper measurements the following needs to be considered:

F the analytic error of the unit under test;

$\pm M$ the measuring error of the test set;

T the test limits while producing;

F_{\max} the maximum possible error for the unit under test,
then the guaranteed error limit $G = F + |2 M| = F_{\max}$ (see also figure B.1).

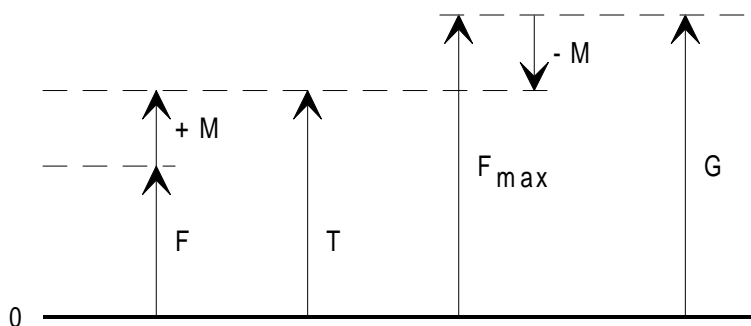

Figure B.1: Worst case error "G"

Facit: In order to minimize the difference $G - F$ the accuracy of the test instrument, $|M|$ should be $\ll F$.

When the test instruments comply with the following requirements to their accuracy and all other components are within $\pm 1\%$ of their nominal value, compliance to the requirements is to be assumed when the values read off the instruments comply.

B.2 Measurement capabilities

The main test instrument should be able to measure all those parameters on the various PBXs as listed in table B.1.

Table B.1: Measurement capabilities

Parameter	Measuring Configuration	according to CCITT Recommendation	Measurement Facility
Transmission loss	A, B, C, D	O.133 [18]	E
Echo and stability	C, D		
Impedance (return loss)	A, B	O.133 [18]	E
Unbalance	A, B, C	O.9 [14], G.117, O.133 [18]	E
Loss distortion with frequency	A, B, C, D		E
Absolute group delay	A, B, C, D		E
Group delay distortion	A, B		O
Weighted noise	A, B, C, D	O.133 [18]	E
Discrimination against out of band signals	A ^{*)} , B, D		O
Spurious out of band signals	A, B ^{*)} , C		O
Single frequency noise	B ^{*)}		O
Total distortion inclusive quantizing distortion	A, B, C, D	O.132 [17], O.133 [18]	E
Variation of gain with input level	A, B, C, D	O.133 [18]	E
Crosstalk	A, B / C, B / A, D		E
A = Analogue signal generator B = Analogue signal analyser C = Digital signal generator D = Digital signal analyser E = Essential O = Optional *) frequency range 4,6 kHz to 72 kHz			

B.3 Instrument requirements

This paragraph describes the minimum requirements to be met by the four functional units of the instrumentation. Measuring accuracy is given in subclause B.4.

Test instruments equipped with standardized digital interfaces and their interworking with the AP, see subclause A.2.2.

Analogue test instrumentation impedances needs to be in accordance with subclause A.1.4.

The output- and input-impedances, of the analogue test instrumentation is to be balanced and earthfree. It is recommended, that the following impedance values are provided:

Output impedance: 600 Ω , 0 Ω , complex (optional)

Input impedance : 600 Ω , > 30 k Ω , complex (optional)

NOTE: For different complex impedances the use of an external impedance converter is recommended.

The requirements for return loss against 600 Ω (or complex impedance) and Longitudinal Conversion Loss (LCL) for input and output impedances are:

600 Ω:	200 Hz to 4 000 Hz	> 46 dB
Complex:	200 Hz to 500 Hz	> 36 dB
	500 Hz to 2 500 Hz	> 40 dB
	2500 Hz to 4 000 Hz	> 36 dB

For unbalance measurements the LCL of the test instrument itself should be ≥ 66 dB in the range from 15 Hz to 4 kHz.

B.4 Measuring accuracy

Considering the measuring accuracy the following facts shall be taken into account.

Even ideal coders/decoders exhibit intrinsic limitations due to the PCM-process which cannot be avoided (see annex A of ITU-T Recommendation O.133 [18]).

The measuring instrumentation described here has no better characteristics and limitations as an ideal coder/decoder. Therefore, the difference between an ideal coder/decoder and the measuring instrument are defined as measuring errors in this ETS.

The total measuring error limits for the test instrumentation can be mainly derived by the sum of errors according to the different configurations of the functional units.

In the following tables the error limits are listed, depending on the type of parameter to be measured and the type of connection.

Table B.2: Error limits for transmission loss

Parameter	Error limits [dB]		
	Output/input connection	Half connection	
	IMP ←→ AP	IMP	AP
Relative levels*) (Transmission Loss)	± 0,08	—	—

*) Measured at a frequency of 1 020 + 2 / -7 Hz and at a level of 0 dBm0.

Table B.3: Error limits for echo and stability

Parameter	Error limits [dB]		
	Output/input connection	Half connection	
	IMP ←→ AP	IMP	AP
TBRL, echo, stability	—	—	± 0,1

Table B.4: Error limits for impedance measurements (return loss)

Parameter	Indicated result	Error limits [dB]		
		Output/input connection	Half connection	
		IMP ←→ AP	IMP	AP
Return loss	0 dB to 30 dB	—	± 1	—
	30 dB to 40 dB	—	± 2	—

Table B.5: Error limits for unbalance measurements

Parameter	Indicated result	Error limits [dB]			
		Output/input connection		Half connection	
		IMP \longleftrightarrow AP		IMP	AP
Unbalance about earth	5 dB to 40 dB	—		$\pm 1,5$	—
	40 dB to 56 dB	—		$\pm 2,5$	—

Measured at a level of ≥ -10 dBm₀.

Table B.6: Error limits for loss distortion with frequency

Parameter	Frequency range	Error limits [dB]			
		Output/input connection		Half connection	
		IMP \longleftrightarrow AP		IMP	AP
Loss distortion with frequency	200 Hz to 300 Hz	$\pm 0,08$		—	—
	300 Hz to 3 400 Hz	$\pm 0,05$		—	—
	3 400 Hz to 3 600 Hz	$\pm 0,08$		—	—

Measured at a level of 0 dBm₀ or -10 dBm₀ and referred to a frequency of 1 020 $\pm 2/-7$ Hz.

Table B.7: Error limits for absolute group delay

Parameter	Receive level	Error limits [μ s]			
		Output/input connection		Half connection	
		IMP \longleftrightarrow IMP		IMP	AP
Absolute group delay	0 dBm ₀ to -10 dBm ₀	$\pm 15^*)$		—	—

*) Due to total distortion including quantizing distortion of the PBX, measurement is proposed in the range 500 Hz to 2 800 Hz.

Table B.8: Error limits for group delay distortion

Parameter	Frequency range	Error limits [μ s]			
		Output/input connection		Half connection	
		IMP \longleftrightarrow AP		IMP	AP
Group delay distortion	0 dBm ₀ to -10 dBm ₀	$\pm 30^*)$		—	—

*) Due to total distortion including quantizing distortion of the PBX, measurement is proposed in the range 500 Hz to 2 800 Hz.

Table B.9: Error limits for weighted noise

Parameter	Indicated result	Error limits [dB]			
		Output/input connection		Half connection	
		IMP \longleftrightarrow AP		IMP	AP
Weighted noise	- 80 dBm _{0p} to - 75 dBm _{0p}	$\pm 2,5$		—	—
	- 75 dBm _{0p} to - 70 dBm _{0p}	$\pm 1,5$		—	—
	- 70 dBm _{0p} to - 20 dBm _{0p}	± 1		—	—

Measurement error includes tolerances of the weighting filter given in ITU-T Recommendation O.41 [15]

Table B.10: Error limits for discrimination against out-of-band signals

Parameter	Error limits [dB]		
	Output/input connection	Half connection	
	IMP \longleftrightarrow AP	IMP	AP
Discrimination against out-of-band input signals	$\pm 0,5$	—	—

The test signal is a sine-wave above 4,6 kHz with a level of -25 dBm0.

Table B.11: Error limits for spurious out-of band signals at the PBX output

Parameter	Error limits [dB]		
	Output/input connection	Half connection	
	IMP \longleftarrow AP	IMP	AP
Spurious out-of-band signals at the PBX output	$\pm 0,5$	—	—

The test signal is a sine-wave in the range 300 Hz to 3 400 Hz with 0 dBm0.
 The received inband-signal is to be measured selectively.

Table B.12: Error limits for single frequency noise at the PBX output

Parameter	Error limits [dB]		
	Output/input connection	Half connection	
	IMP	IMP	AP
Single frequency noise	± 1	—	—

The received output signal has to be measured selectively.

Table B.13: Error limits for total distortion including quantizing distortion

Parameter	Indicated result	Error limits [dB]		
		Output/input connection	Half connection	
		IMP \longleftrightarrow AP	IMP	AP
Total distortion	0 dB to 40 dB	$\pm 0,5$	—	—
	40 dB to 43 dB	± 1	—	—

Measured with sinusoidal test signal of approximately 1 020 Hz. The absolute distortion signal is not less than -72 dBm0.

Table B.14: Error limits for variation of gain with input level

Parameter	Level range	Error limits [μ s]		
		Output/input connection	Half connection	
		IMP \longleftrightarrow AP	IMP	AP
Variation of gain with input level	+3 dBm0 to -40 dBm0	$\pm 0,1$	—	—
	-40 dBm0 to -50 dBm0	$\pm 0,15$	—	—
	-50 dBm0 to -55 dBm0	$\pm 0,20$	—	—

Error referred to measurement of -10 dBm0. The test signal is sinusoidal at a frequency of 1 020 +2/-7 Hz and a level of -10 dBm0.

Table B.15: Error limits for crosstalk measurement

Parameter	Test signal	Error limits [dB]		
		Output/input connection	Half connection	
		IMP \longleftrightarrow AP	IMP	AP
Cross-talk	Sinus 1 020 Hz ^{*)}	± 1	± 1	± 1
	Convent. teleph.	—	$\pm 1,5$	—
*) Measurement to be performed while injecting an auxiliary signal (defined in subclause 3.2.4 of ITU-T Recommendation O.133 [18]) in the disturbed PBX. Error includes the effect of finite rejection of the auxiliary signal by the measurement filter and of quantizing distortion in the measuring bandwidth.				

Annex C (informative): Relationship between the units dBm, dBr and dBm0

C.1 General

Transmission values for loss, gain and levels are expressed in decibels (dB) as a general principle. The basic unit "dB" is often extended with additional letters in order to distinguish between its use in different applications. The aim of this annex is to give a short description of the most common forms as used for transmission measurements at speech band frequencies as well as an introductory explanation of certain transmission planning applications. See also annex D for a more complete discussion.

C.2 The unit "dB"

This basic unit is mainly used for losses, gains, return losses, etc., i.e. as a logarithmic ratio between two values which can be voltages, currents, powers, acoustic pressures etc. If the ratio is X for voltages, currents, pressures, the dB expression is $20 \log (X)$. If the ratio is Y for powers, the dB expression is $10 \log (Y)$.

C.3 The unit "dBm"

This unit with the additional "m" is used as a logarithmic measure of the "magnitude" P of an actual signal. The "dBm value" of a signal is called its "absolute power level" or "absolute level".

The signal magnitude P used for signal characterization in speechband applications has the dimension of power, i.e. expressed in mW or mVA, and has by definition the form:

$$P = \frac{1\,000 \times (V)^2}{|Z(f_0)|} \quad [\text{mW}] \text{ or } [\text{mVA}]$$

where:

V: the rms value in volts of the voltage across the test impedance Z which in the general case is complex and frequency dependent.

Z (f₀): the value of the test impedance in ohms at the (sinusoidal) reference frequency f₀ = 1 020 Hz.

The choice of this definition is based on three conventions:

- firstly, it is practical to characterize the signal magnitude by a unit that has the dimension of power because this has been the practice for the special case of resistive terminations;
- secondly, electronic circuits are designed to react on voltages, i.e. the open-circuit output voltage of, for instance, an amplifier depends only upon the voltage across its input terminals, irrespective of the input and output impedances of the amplifier. Thus, the "power" absorbed by the input impedance of the amplifier has no influence of how the signal is amplified. Hence the use of a constant impedance value in the denominator instead of a frequency dependant impedance;
- thirdly, a sinusoidal signal with the reference frequency (1 020 Hz) the numeric value of P shall be equal to the apparent power absorbed by Z, when this is complex, which is the same as the active power when Z is resistive.

Note that P is equal to the active power absorbed by the test impedance Z only when the latter is purely resistive and constant with frequency, for instance when Z = 600 Ω. Then P is measured in mW, otherwise in mVA. However, when Z is complex, the value of P does not represent the apparent power absorbed by the test impedance at other frequencies than the reference frequency 1 020 Hz.

The definition for the so-called absolute power level L is:

$$L = 10 \log \frac{P}{P_0} \quad [\text{dBm}]$$

where:

P: the power in mW to be stated;

P₀: the reference value which is P₀ = 1 mW.

Likewise, in the speech band the loss between two analogue points 1 and 2 is defined to be:

$$A(f) = 10 \log \left\{ \frac{P_1(f)}{P_2(f)} \right\} = 20 \log \left\{ \frac{V_1(f)}{V_2(f)} \sqrt{\frac{|Z_2(f_0)|}{|Z_1(f_0)|}} \right\} \quad [\text{dB}]$$

Sometimes the unit "dBm" is used in conjunction with a voltage level, referred to a voltage of 0,775 V. The use of "dBm" in this application is only correct if the test impedance is 600 Ω resistive since 0,775 V across 600 Ω results in the reference active power of 1 mW. This fact is important to remember if capacitive complex interfaces or test impedances are used.

C.4 The unit "dBr"

This unit is used to characterize "relative levels", i.e. to express the level relations for signals between points in a signal path, with the convention that one of the points is designated as a level reference point with the relative level 0 dBr.

More specifically, a sinusoidal reference signal of 1 020 Hz in the speech band is thought to pass the signal path under consideration with such an amplitude that its absolute level is 0 dBm at the 0 dBr point. The relative level in dBr at any other point in this signal path is then equal to the level (in dBm) that the reference signal has at that point. (Note that relative level designations should be used for both transmission directions).

If the level reference point is digital, normally the reference signal is thought of as being decoded by an ideal decoder at which output terminal a power of 1 mW is produced, termination 600 Ω resistive (see also annex D).

The relative level concept is very practical for the transmission aspects of telecommunications in several ways. It is a method for matching the power handling capacity of the transmission equipment in a connection to the levels of the actual signals in the network. Loss and gain in the network can be specified by means of relative levels. Also, relative levels can be used to characterize parameters of certain components of an equipment.

Note, however, that the application rules for relative levels depend on in which context they are used.

It is immediately apparent that the differences of the relative levels between two points, which have the same level reference point, correspond to the loss or gain between those two points (at the reference frequency).

Moreover, relative levels are used to characterize the "power" handling capabilities of components (such as codecs) and equipment on the one hand and the expected levels of actual signals in the network on the other hand. This will be discussed in more detail in the following subclauses.

The "signal path under consideration", for which a specific 0 dBr reference point is designated, can encompass:

- a single component, such as an encoder or decoder;
- an equipment, such as a half-channel of a digital exchange;
- a circuit in the sense of the ITU-T definition, i.e. the fixed connection between two exchanges.

In the first two cases the "power handling capability" is the guiding principle for the allocation of a level reference point. For the third case the "expected absolute levels of actual signals" determines the choice of the level reference point.

The aim is of course to match the component performance to the requirement for the equipment performance which in turn should be matched to the actual range of signal levels. However, it is not always possible to achieve this exactly. For this and other reasons, the allocation of the 0 dBr reference point in the signal path may be chosen differently in the three cases above, i.e. when the component is considered alone, when it is considered as part of the equipment, and when the equipment is a part of the circuit. This means that the relative level designation for a certain point sometimes may differ in these three cases, a fact which should be remembered when discussing relative levels.

NOTE: It would be easy to surmise that there is only one level reference point in the network to which all relative levels are referred. However, this is not the case. As a matter of fact, in a complete connection, several different level reference points can be designated. These may also be different from those chosen when the parts of the transmission links are considered separately in the context of parameters for equipment or components. Thus, when stating the relative level at a point one should make it quite clear in which context this relative level applies.

A more detailed discussion of the various applications of relative levels is given in annex D (see also ITU-T Recommendations G.100 and G.101 [3]).

Note that a so-called "level jump" may be introduced at the interconnection point between two (ITU-T) circuits. Thus, the loss or gain between two points belonging to two different circuits is not always equal to the difference in their (circuit) relative levels. Such an example is the case of the input and output relative levels of a digital exchange having no digital loss or gain pads. When the exchange is considered as an equipment, the difference between the (equipment) input and output relative levels gives the loss through the exchange because the two half-channels have the same level reference point. When the exchange is considered as a part of a connection, the two half-channels belong to two different (ITU-T) circuits which are interconnected "in the middle of" the switching matrix. The (circuit) input and output relative levels for the exchange, which are stated in the transmission plan for the connection, can differ from the specified (equipment) relative levels. This is because the (circuit) relative levels refer to two separate level reference points, each determined by estimation of expected signal levels in the two circuits (in general, however, the differences are not very large).

For the purpose of equipment parameter specification and transmission measurement, which is of interest here, the "power handling capability" is the governing factor for the choice of the 0 dBr level reference point. In this context, the digital 64 kbit/s PCM bit-stream is considered as having a relative level of 0 dBr, provided that there are no digital loss or gain pads in its path. Ideal encoders and decoders connected to the bit-stream are defined as having 0 dBr relative levels at their analogue ports when their clipping level for a sinusoidal signal lies at +3,14 dBm (A-law). The relative level for real encoders and decoders connected to the bit-stream is determined by means of the actual clipping levels in relation to the clipping levels of the ideal codecs.

When a digital loss or gain pad is included in the digital bit-stream, one has to make a choice of which side of the pad the bit-stream is to be assigned to 0 dBr. In the context of equipment specification and transmission measurement, it has been found most practical to apply a convention that a digital bit-stream never should be assigned a higher relative level than 0 dBr. This means that:

- a digital pad with L dB loss has the relative levels of 0 dBr at the input and -L dBr at the output;
- a digital pad with G dB gain has the relative levels of -G dBr at the input and 0 dBr at the output.

Note that in the context of transmission planning, a digital bit-stream sometimes may be assigned a relative level which is different from 0 dBr even if there is no digital pad in the digital path (see clause D.3).

Subclause D.4.3 lists another couple of possible choices of the 0 dBr point in digital exchanges.

C.5 The unit "dBm0"

When using an additional "m" and "0" (zero) with the basic "dB", the level under consideration is expressed as the absolute level (dBm) of the same signal that would be measured at the relevant 0 dBr level reference point.

This term is used in conjunction with transmission measurements to specify test levels and test results; the term also facilitates the comparison of the power levels of different signals by referring them to a

common reference point, i.e. the 0 dBr reference point. Networks are often designed to carry different types of signals (speech, modem, fax, etc.) at different levels, expressed in dBm0.

C.6 The letter "p" in "dBmp" and "dBm0p"

The additional small letter "p" is derived from the French word "ponderé" for "weighted" and means that the considered value is a noise level, measured by a psophometer with a special noise weighting filter included as described in ITU-T Recommendations O.41 [15] and P.53 [20].

C.7 The relationship between dBm, dBr and dBm0

The relationship between relative levels at interfaces, which have the same level reference point, and the resulting transmission loss or gain "L", is given by the formula:

$$L = L_i - L_o$$

where L_i and L_o are the relative input- and output levels at the interfaces (see also subclause 3.1.4.1).

The relation between the terms dBm, dBr and dBm0 can be expressed by the following formula:

$$\text{dBm} = \text{dBm0} + \text{dBr} \quad (\text{general})$$

$$\text{dBmp} = \text{dBm0p} + \text{dBr} \quad (\text{for weighted noise})$$

or

$$\text{dBm0} = \text{dBm} - \text{dBr} \quad (\text{general})$$

$$\text{dBm0p} = \text{dBmp} - \text{dBr} \quad (\text{for weighted noise})$$

EXAMPLE 1: The test level for an interface with an input relative level of $L_i = -2$ dBr, is required to be -10 dBm0. To what absolute power level in dBm the signal generator should be adjusted?

$$\begin{aligned} \text{dBm} &= \text{dBm0} + \text{dBr} \\ &= -10 + (-2) = -12 \text{ dBm.} \end{aligned}$$

EXAMPLE 2: The dial tone level at an interface with an output relative level of $L_o = -7$ dBr was measured with -19 dBm. Does this value meet the requirement given with ≤ -15 dBm0 for this type of interface?

$$\begin{aligned} \text{dBm0} &= \text{dBm} - \text{dBr} \\ &= -19 - (-7) = -12 \text{ dBm0.} \end{aligned}$$

The result shows, that the dial tone level is outside the limit.

NOTE: Some modern test instruments are providing as well an automatic adjustment of the correct absolute test level, as the necessary correction of received levels and displaying the results in "dBm0". In those cases the above given calculation can be avoided, however an additional adjustment (beside the test level itself) is required, to adapt the test instrument to the relative input- and output levels of the test object.

C.8 Correction factors

Depending on the type of test instruments, auxiliary equipment and test objects, sometimes correction factors need to be used, to either adjust the correct test signal level, or to obtain the correct test result. This mainly occurs in conjunction with capacitive complex impedances.

In practice, test instruments may be used with input/output impedances only 600Ω resistive and consequently send levels or displayed results referred to 1 mW. To provide the correct termination of test objects with complex impedances, auxiliary equipments called "impedance converter" are used. The

principle of such an impedance converter is shown in figure C.1 in the application for sending and in figure C.2 for receiving.

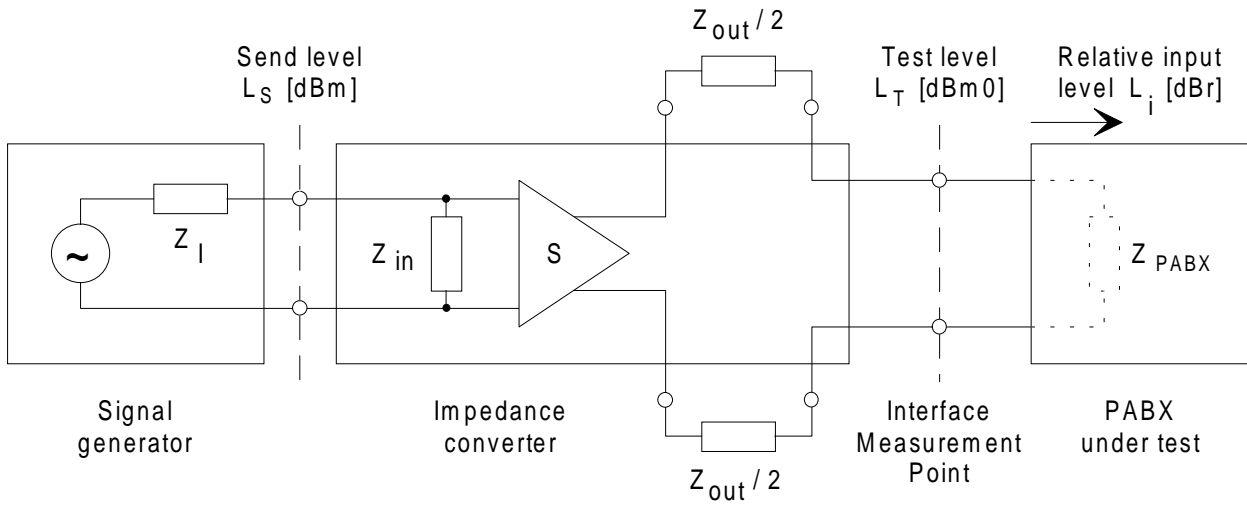

Figure C.1: Impedance converter in the sending path

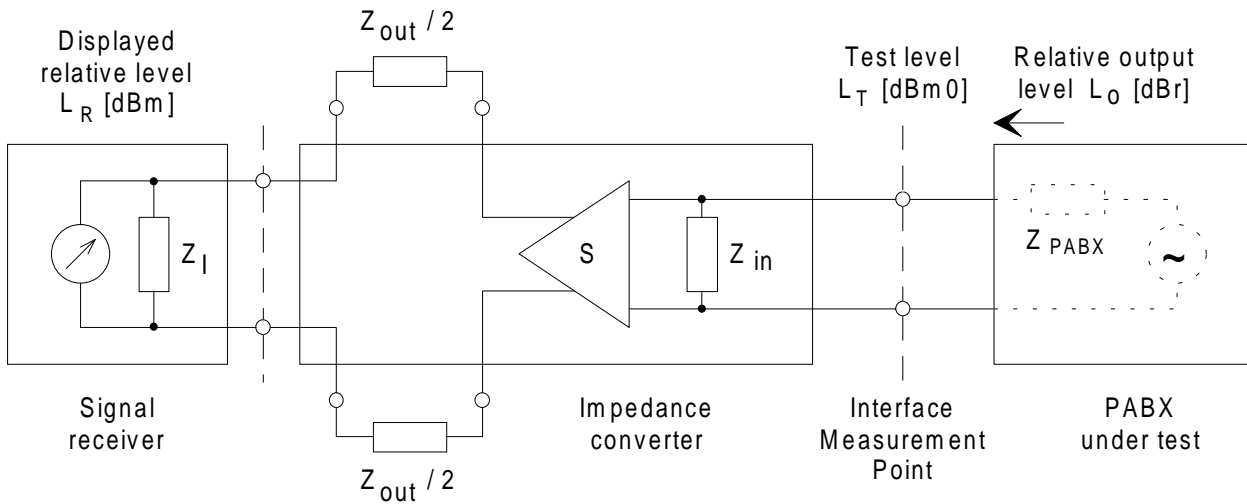

Figure C.2: Impedance converter in the receive path

An advantageous design is, to obtain a power transfer ratio of 1 at the reference frequency 1 020 Hz, if terminated with the respective nominal impedances at input and output. In this case the voltage gain "s" of the inserted amplifier is:

$$s = 6 + 10 \log \frac{Z_{out}}{Z_{in}} \text{ [dB]}$$

This formula is valid for send and receive part of an impedance converter. It should be noted, that if Z_{out} or Z_{in} is a complex impedance, the modulus at the reference frequency 1 020 Hz has to be used.

For impedance converters in the application with different complex impedances the gain "s" is normally only adjusted to 6 dB (power transfer ratio = 1 only, if $Z_{in} = Z_{out}$) and correction values are used as follows:

Sending a test signal

In this application (see figure C.1) Z_{in} is exactly matched to the impedance Z_i of the signal generator (e.g. 600 Ω) and Z_{out} is the nominal value of the interface impedance Z_{PABX} of the PBX under test.

To obtain the required test level L_T in dBm0 at the IMP, the necessary send level L_S in dBm of the signal generator can be calculated as follows:

$$L_S [\text{dBm}] = L_T [\text{dBm0}] + L_i [\text{dBr}] + 10 \log \frac{Z_{\text{out}}}{Z_{\text{in}}}$$

EXAMPLE 3:

For an interface of the PBX under test with an input relative level $L_i = -5$ dBr and a nominal impedance $Z_{\text{PBX}} = 842 \Omega$ (modula at 1 020 Hz for a 3-element complex impedance with $270 \Omega + 750 \Omega // 150\text{nF}$) a test level of $L_T = -10$ dBm0 shall be provided. What is the necessary send level L_S in dBm at a signal generator with 600Ω impedance?

$$L_S [\text{dBm}] = L_T [\text{dBm0}] + L_i [\text{dBr}] + 10 \log \frac{Z_{\text{out}}}{Z_{\text{in}}}$$

$$L_S = -10 \text{ dBm0} + (-5 \text{ dBr}) + 10 \log \frac{842}{600}$$

$$\underline{\underline{L_S = -13,53 \text{ dBm}}}$$

Receiving a test signal

For receiving (see figure C.2) Z_{out} is exactly matched to the instrument impedance Z_i and Z_{in} provides the nominal termination of the IUT with the impedance Z_{PBX} .

To obtain the correct (received) test level L_T in dBm0 at the IMP, the displayed receive level L_R in dBm at the signal receiver needs to be corrected, using the following formula:

$$L_T [\text{dBm0}] = L_R [\text{dBm}] - L_o [\text{dBr}] + 10 \log \frac{Z_{\text{out}}}{Z_{\text{in}}}$$

EXAMPLE 4:

Assuming the same impedances for the test instrument (600Ω) and the PBX under test (842Ω) as in example 3, but with an output relative level of $L_o = -7$ dBr, what is the correct received test level L_T if the signal receiver readout is $L_R = -50$ dBm?

$$L_T [\text{dBm0}] = L_R [\text{dBm}] - L_o [\text{dBr}] + 10 \log \frac{Z_{\text{out}}}{Z_{\text{in}}}$$

$$L_T = -50 \text{ dBm} - (-7 \text{ dBr}) + 10 \log \frac{600}{842}$$

$$\underline{\underline{L_T = -44,47 \text{ dBm0}}}$$

Annex D (informative): The concept of "relative levels"

D.1 General principles

As already mentioned in annex C, the concept of relative level is applied in many areas.

In transmission planning, relative levels are used to characterize "probable signal power levels" occurring in the circuits of the network.

In transmission maintenance, relative levels are used to describe loss or gain between points as well as defining levels of test signals.

For the specification and design of an equipment, relative levels are used to describe the power handling capabilities when the equipment is employed in a transmission chain.

In testing of equipment and components, relative levels are used to characterize signal parameters.

In the ideal case, the power handling capabilities of components and equipment would be accurately matched to the actual signal powers they encounter when used in the network. In practice, this is not always achievable or even desirable. For instance, in equipment design, the relative level designations for testing components do not always correspond exactly to the specified relative levels for the equipment considered as a unit.

However, the distinctions between the different applications of "relative levels" have not always been clearly stated, not even in ITU-T documents, which sometimes has caused confusion.

Often it is clear what a relative level value refers to. However, there is a risk of misunderstanding. It is a wise precaution to make a direct statement, such as:

- (test) relative level;
- (equipment) relative level;
- (circuit) relative level.

As an example of misunderstanding, the relative levels given in a transmission plan have sometimes erroneously been taken to exactly correspond to test levels of equipment.

In the following, examples are given of "good engineering practice" with regard to relative level applications. The rules should be considered as having a certain amount of flexibility. Most difficulties seem to have occurred in conjunction with digital transmission. Therefore, digital cases are given special attention.

D.2 The speech signal and the dynamic range of the voice channel

During normal, active speech periods, the variation in level between different speakers has a standard deviation of about 3 dB as recorded with a fixed distance mouth to microphone. However, when speakers are using actual telephone handsets, held according to individual preferences, the standard deviation is increased by up to 5 dB.

The performance of Frequency Division Multiplex (FDM) (carrier) equipment is governed by the total channel load. That means that the **mean** channel load capacity is of importance. According to a CCITT design recommendation, this should be -15 dBm₀, with speech pauses included and consideration taken of some extraneous signals. This translates into -11 dBm₀ for the actual speech periods.

For PCM systems, the individual channel performance should be matched to the **dynamic range** of the speech signals. Therefore, it is of interest to study the instantaneous amplitude distribution of speech signals.

It is practical to relate the absolute amplitude V of speech signals to the root mean square (rms) - value of the speech signal (V_{eff}) during active speech periods. Investigations have shown that the statistical distribution can be simulated by the function:

$$P(X) = \frac{K}{\Gamma(L)} (KX)^{L-1} e^{-KX}$$

where: $X = \frac{V}{V_{\text{eff}}}$, $L = \text{a constant}$, $K = \sqrt{L(L+1)}$, $\Gamma = \text{the } \Gamma\text{-function}$.

The constant L is about 0,5 for handsets with modern linear microphones (for older, carbon types $L = 0,2$).

The equation as shown above is to be interpreted as follows:

The probability to find a value in the interval $X \pm dX/2$ is $P(X) dX$.

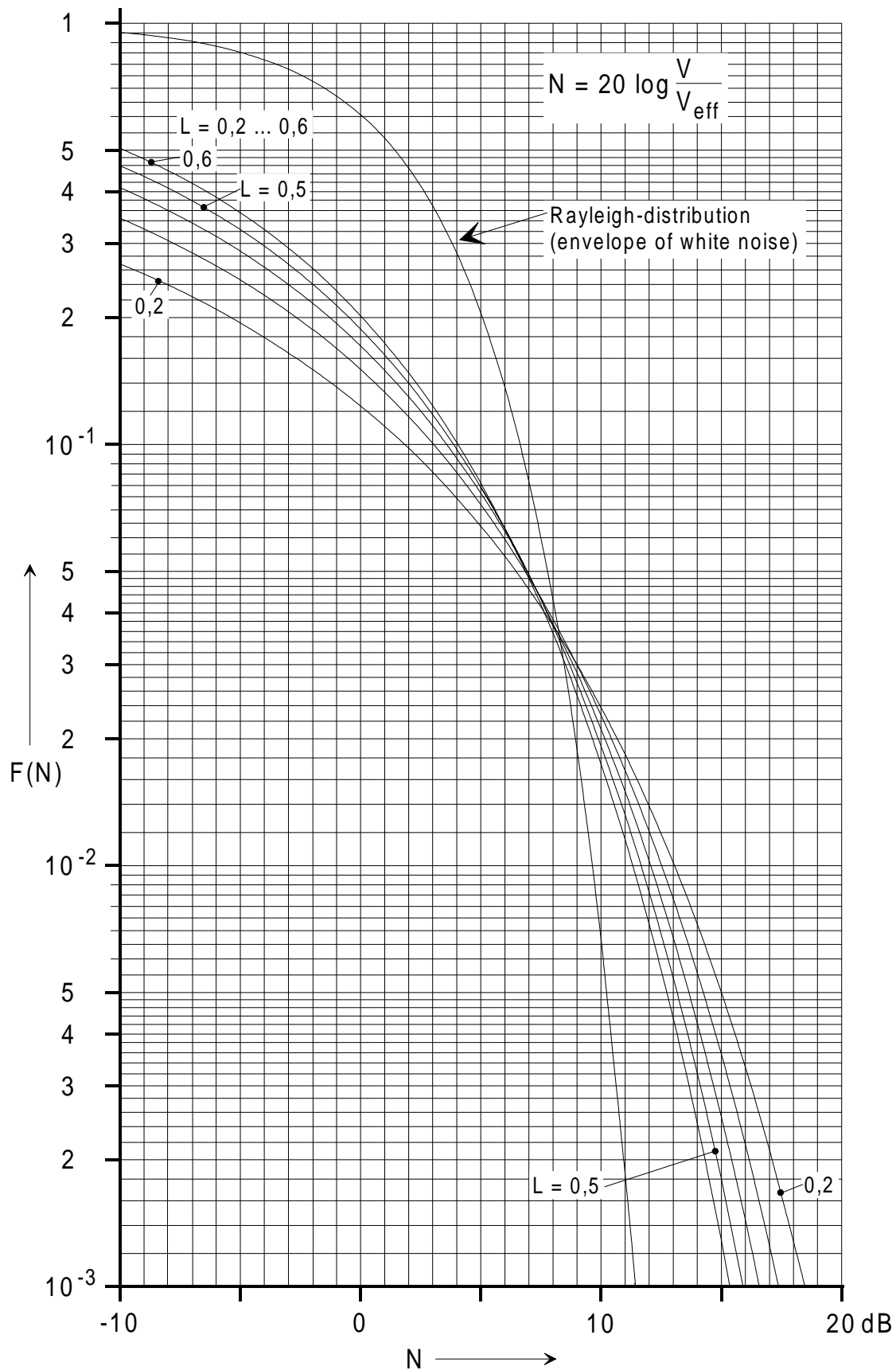

Figure D.1: Statistical distribution of speech signals

From the above equation the cumulative statistical distribution $F(X)$ can be computed. This is depicted in figure D.1 with $N = 20 \log (V/V_{\text{eff}})$ as abscissa and $L = 0,2...0,6$. For comparison, a similar curve is drawn for the envelope of band-limited white noise signals.

It is apparent from the figure that speech signals are more "peaky" than white noise. However, for those peak values, that only are exceeded 1 % of the time, the difference is only about 2 dB for the most common value $L = 0,5$. The 1 % probability value corresponds to $N = 12$ dB. Subjective tests indicate that this is an acceptable lower limit for speech clipping. Measured absolute peak values of speech lie at about 18 dB above the rms value, but those peaks occur very infrequently.

The dynamic range of 64 kbit/s PCM codecs can be described in many ways. One method is to look at the limits for the signal-to-total distortion ratio as depicted in figure A.5 of CCITT Recommendation G.712 [12] which is reproduced here in figure D.2. This curve applies for white noise as an input signal (method 1).

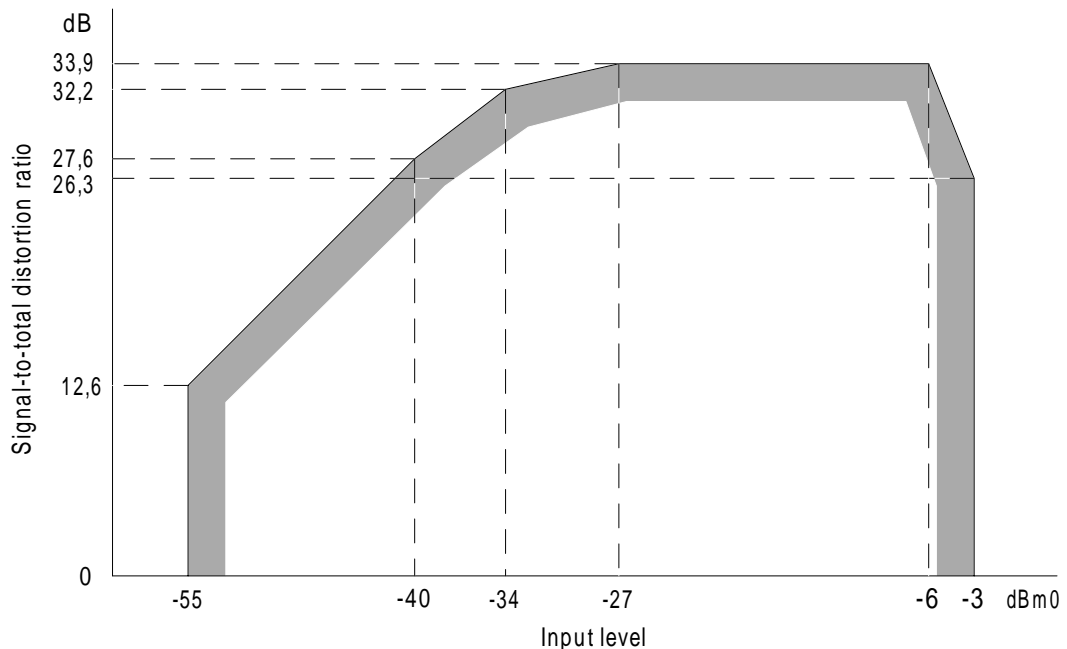

Figure D.2: Signal-to-total distortion ratio as a function of input level (method 1)

One can see from the figure that the signal-to-total distortion ratio curve is flat from - 27 dBm0 to -6 dBm0 white noise input signal. The upper limit corresponds to the level when peak clipping begins to take effect. However, the decrease in signal-to-total distortion ratio is quite moderate for - 3 dBm0 input level.

The peak clipping level for sinusoidal signals is + 3 dBm0, i.e. the absolute peak limit level is 6 dBm0. Thus, in the range when the peak clipping begins to take effect for white noise, the margin between the peak limit and the rms value of the noise lies between:

$$6 \text{ dB} + 3 \text{ dB} = 9 \text{ dB} \text{ and } 6 \text{ dB} + 6 \text{ dB} = 12 \text{ dB}.$$

Using speech signals, these values should be increased by 2 dB, giving a desirable margin in the range of 11 dB to 14 dB. This corresponds well with the subjectively established value of 12 dB.

What actual speech levels can be expected in the network compared to the nominal speech level?

According to a recent investigations, a "reference talker" (i.e. talking a with -4,7 dBPa mean speech sound pressure at the MRP) produces during active speech at a 0 dBr point a signal level of:

$$N = - 11 - \text{SLR} \quad [\text{dBm0}]$$

where SLR is referred to the 0 dBr point.

By using the above formula, one can compute the margin C at the average speech level against "just noticeable" speech clipping, i.e. at 12 dB higher than the rms value. Also, using the standard deviation of 5 dB for speech levels one can estimate the percentage P_c of talkers who talk so loudly that they are subjected to clipping. Thus:

$$\text{For the nominal SLR} = 7 \text{ dB: } C = 12 \text{ dB, } P_c = 0,8 \text{ \%};$$

For the minimum SLR = 2 dB: $C = 7$ dB, $P_c = 8$ %.

It appears that $SLR > 2$ gives a reasonable protection against objectionable speech clipping.

NOTE: Actual speech levels in networks are currently being studied in the ITU-T.

Thus, for normal connections there are no problems in the matching between the dynamic ranges of the speech signal and the codecs. Moreover, it appears that reasonable margins exist in the 64 kbit/s PCM channel so that the nominal speech level can be increased by 2 or 3 dB or decreased by 6 dB from its normal value of -11 dBm0 without objectionable results. (This is confirmed by some early subjective tests performed with the help of the Modulated Noise Reference Unit (MNRU) method).

Examples of such level shifts occur when digital loss or gain is used or when so-called level jumps have to be introduced between (ITU-T) circuits (see clauses D.4 and D.5). Formally, this can be handled by assigning relative levels **differing from 0 dBr** to the digital bit stream. This is discussed in subclauses D.3 to D.5.

D.3 Relative level designations for a digital path

Most often, the digital path is assigned to the relative level 0 dBr. The absolute level of a signal in a 64 kbit/s PCM path is then determined by ideal encoders and decoders as shown in figure D.3.

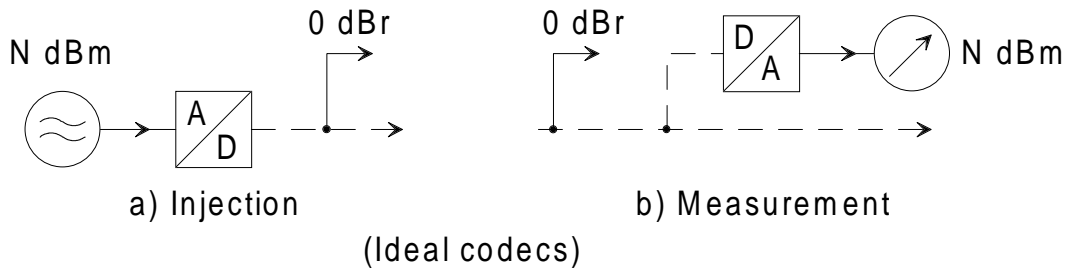

Figure D.3: Interpretation of absolute signal level in a digital path with relative level 0 dBr

The analogue 0 dBm0 reference signal, corresponding to $N = 0$ in figure D.3, has its counterpart in the standard Digital Reference Sequence (DRS).

In some exceptional cases, it is practical to assign a relative level L dBr, **differing from 0 dBr**, to the digital path. The analogue 0 dBm0 reference signal then corresponds to a different DRS which shall be termed DRS (L dBr) for clarity. The injection and detection of this is depicted in figure D.4.

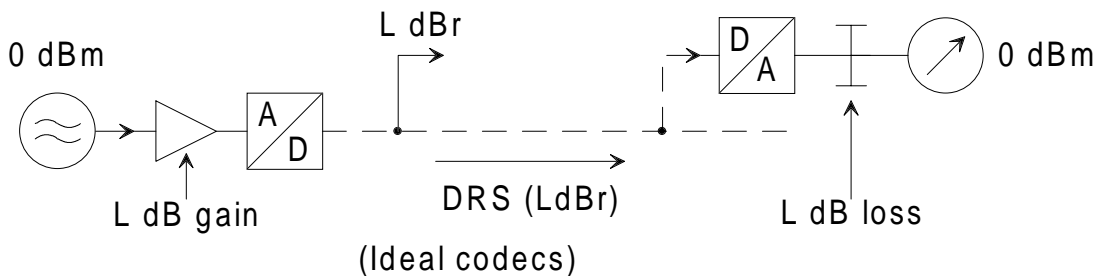

Figure D.4: Interpretation of a 0 dBm0 reference sequence DRS(L dBr) for a digital path with relative level L dBr

- NOTE 1: Negative values of L are chosen more often.
- NOTE 2: In test specifications, positive values of L shall never be used.
- NOTE 3: To create a DRS(L dBr) as shown, $L < 3$ dBr.
- NOTE 4: If $L > 0$ dBr, no sinusoidal signals higher than $(3 - L)$ can be passed without clipping.

Figure D.5 shows level measurement of an actual signal on a digital path with the relative level L.

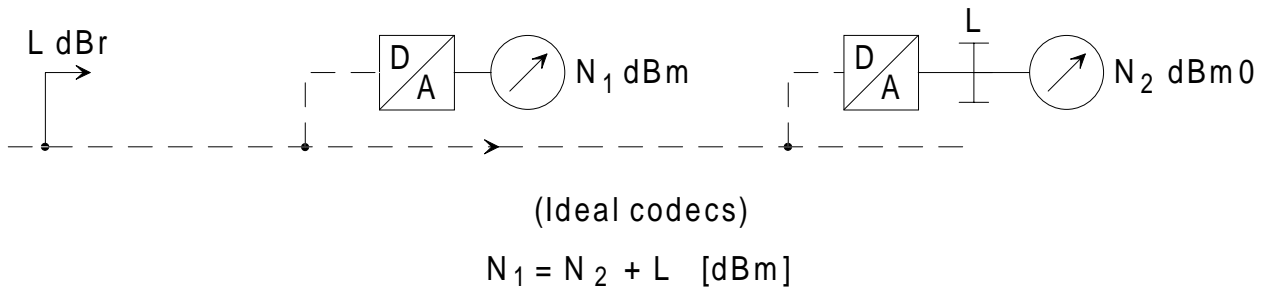

Figure D.5: Level measurements on a digital path with L dBr

D.4 Relative levels in equipment design, specification and testing

D.4.1 Analogue equipment

Large-capacity FDM (carrier) systems are designed to allow, in an up-modulated band, a long-term average of -15 dBm0 per channel, taking into account signalling, carrier leaks and speech pauses. This corresponds to -11 dBm0 actual speech during active periods. (FDM systems with fewer than 240 channels should be designed for a higher average power per channel. For instance, a 12-channel FDM system should be able to handle -7,5 dBm0 per channel).

Voice band analogue equipment is in general designed with regard to relative levels so that noise and clipping do not present any problems (this implies for instance that the clipping level is higher than 3 dBm0).

D.4.2 Codecs and digital pads

For 64 kbit/s **encoders and decoders** regarded as **components** of an equipment, the digital path is taken to represent the 0 dBr level reference point (see figure D.6).



Figure D.6: 0 dBr level reference points for codecs

The performance specification of codecs, as described in CCITT Recommendation G.712 [12] and elsewhere, is based on this convention and the parameters are specified with respect to 0 dBm0 values.

In general, when speech path impairments are considered, **analogue pads, loss or gain**, are to be preferred for level and loss adjustments. However, **digital pads** often allow more flexibility, especially as they can easily be controlled by software.

Experience has shown that digital pads are robust components that do not require such extensive testing as codecs do. Therefore, it has not been necessary to introduce dBm0-values in their specifications.

When codecs and digital pads are combined in an equipment, any performance testing of the equipment should be done with the pads disabled, except of course, during pure loss or gain measurements.

The amount of digital loss or gain should be kept within reasonable limits (see clause D.2).

D.4.3 Digital exchanges

A digital exchange is built up of half-channels interconnected by a switching matrix.

The power handling properties, which are to be used as a basis for the transmission planning of networks, are described by the relative level designations of the exchange ports (however, these values are not necessarily the same as used in performance testing or in the transmission plan).

For all those cases when no digital pads are used, the digital path is considered to be at 0 dBr relative level. Figure D.7 shows as an example the relative level designations for a 2-wire subscriber half-channel.

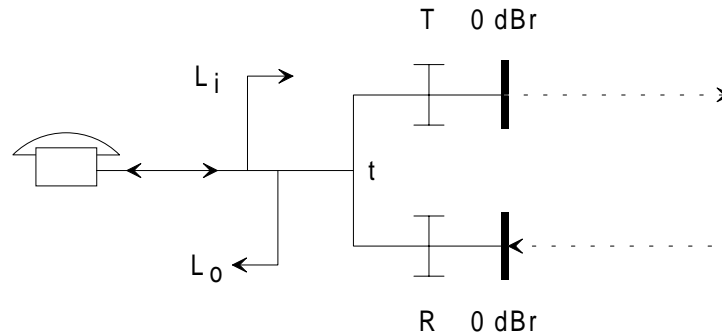

Figure D.7: Relative levels at a local exchange $L_i = T$ dBr, $L_o = -R$ dBr (it is assumed that T and R represent all those losses between t , the 2-wire point, and the digital bit-streams)

When **digital pads** are used, they can either be incorporated in the switching matrix or in the half-channels.

In the first case, the relative level designations for the half-channels remain unchanged.

In the second case, in principle there are several possibilities to designate the 0 dBr reference point:

- a) those digital points which are directly connected to respectively the encoder or decoder;
- b) digital points near the pads, chosen in such a way that the digital relative levels never exceed 0 dBr;
- c) the digital points interfacing the switching matrix.

All cases considered, method c) appears to be the most practical one when specifying data for use in transmission planning.

Figures D.8 and D.9 show examples of how digital loss and gain pads are introduced in the half-channel depicted in figure D.7.

The nominal losses through a half-channel can be found from the relative level designations as shown in figures D.7, D.8 and D.9.

The loss through the exchange is:

$$A = L_i - L_o + SL$$

where L_i , L_o are the input and output relative levels of the half-channels concerned, and SL is the loss of the switching matrix.

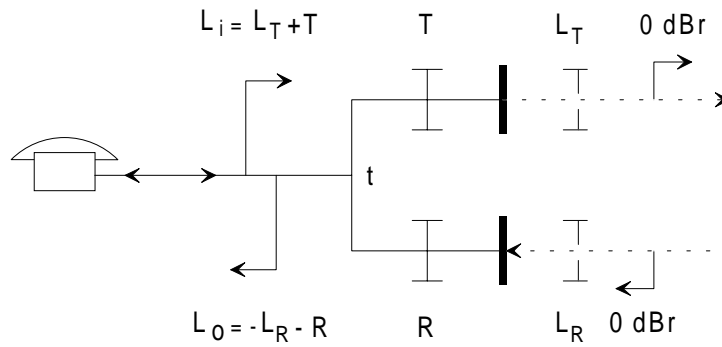

Figure D.8: Relative levels at a local exchange. Digital loss in the half-channel

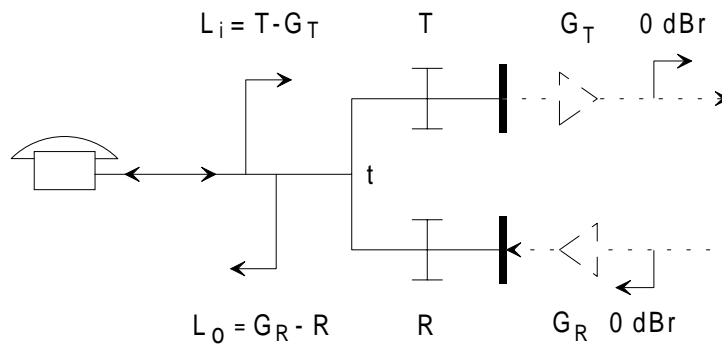

Figure D.9: Relative levels at a local exchange. Digital gain in the half-channel

D.5 Relative levels in transmission planning and maintenance

In transmission planning procedures the overall transmission path is divided into sections in ITU-T vocabulary termed **circuits**, each having its own 0 dBr Transmission Reference Point (TRP). Most often circuits connect switching centres. Sometimes also the subscriber line connected to a local exchange is termed circuit. Thus, a circuit is constituted by all permanently interconnected equipment. In this way maintenance personnel have clearly defined segments with fixed transmission parameters to supervise.

The physical limits of a circuit are sometimes expressed as being situated at "the middle of the exchanges". In this case the exchange terminating equipment is included in the circuit ending in the exchange test point. This practice is common in the public networks and dates back to the times when most exchanges were analogue.

However, the transmission planner has other options to subdivide the connection into circuits, provided he clearly defines the interface. Thus, if the digital switching matrix is designed to introduce loss, the two half-channels 0dBr points may be considered as ending of circuits with the switching matrix as a mini circuit in between.

Exceptionally, the "transmission interface" between the two different maintenance organizations does not lie at an exchange. This may be the case when a public and a private network are interconnected. To divide the responsibilities clearly, one may designate the public and private links as belonging to two different circuits.

One main problem in transmission planning is to obtain a reasonable matching between expected signal levels and the power handling capabilities of the equipment used in each circuit. Sometimes also the relative levels at circuit interconnection points cannot be matched to each other so that "level jumps" have to be introduced.

Regarding a speech level of -11 dBm, at a 0 dBr point, pauses excluded, expected as an average for a large number of subscribers, however, field measurements of actual speech levels in TRPs show a very large spread. By this instead one resorts to some conventions based on general experience.

For normal telephony terminals and subscriber lines, the interconnection to the local exchange can be taken as an "anchor point" to establish a 0 dBr point (see figure D.7). Of course, the speech levels are influenced by the telephony terminal sensitivities. Nevertheless, from annex C of ITU-T Recommendation G.121 [5] it can be seen that many administrations found the optimum values to be $L_i = 0$ dBr, $L_o = -6$ dBr or -7 dBr.

Regarding how the equipment is incorporated in the network, in most cases it will be possible to obtain an exact correspondence between the "equipment" and the "circuit" relative levels. Exceptions sometimes have to be allowed, for instance when for stability reasons extra loss is included in a 4-wire loop. Another reason might be lack of suitable level controls in certain equipment (some echo canceller designs may also need an extra margin against clipping).

An example of additional loss in an analogue 4-wire loop is shown in figure D.10 where an analogue circuit section is interposed between digital circuit sections. To ensure that the risk of instability and "hollowness" of a connection will be insignificant, ITU-T recommends that a 0,5 dB loss is inserted in analogue or mixed digital/analogue circuits. Thus, in the transmission plan for this circuit, part of the digital bit stream will be associated with $-0,5$ dBr.

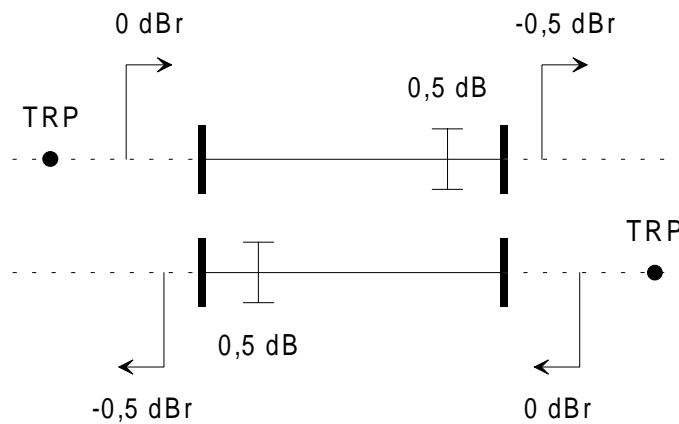

Figure D.10: Example of (circuit) relative levels when an analogue link is interposed in a digital chain

Two adjacent circuits each have their own TRPs to which their respective relative levels are referred. Ideally, at the interface between the circuits the two relative levels should be the same.

Occasionally, the send relative level is set 0,5 dB lower than the receive level in order to guarantee stability, namely when analogue 4-wire transmission is used. For instance, two local exchanges are interconnected via a primary or transit centre with 4-wire analogue switching and transmission. The net loss in the transit path should be 0,5 dB for stability reasons. The relative levels at the local exchanges are determined by the properties of the telephony terminals as mentioned before. Therefore, the 0,5 dB net transmission loss corresponds to a "level-jump" of 0,5 dB at the transit exchange. A similar example of an international transit connection is given in figure D.11 which is a reproduction of figure 2a of CCITT Recommendation Q.45 bis [26].

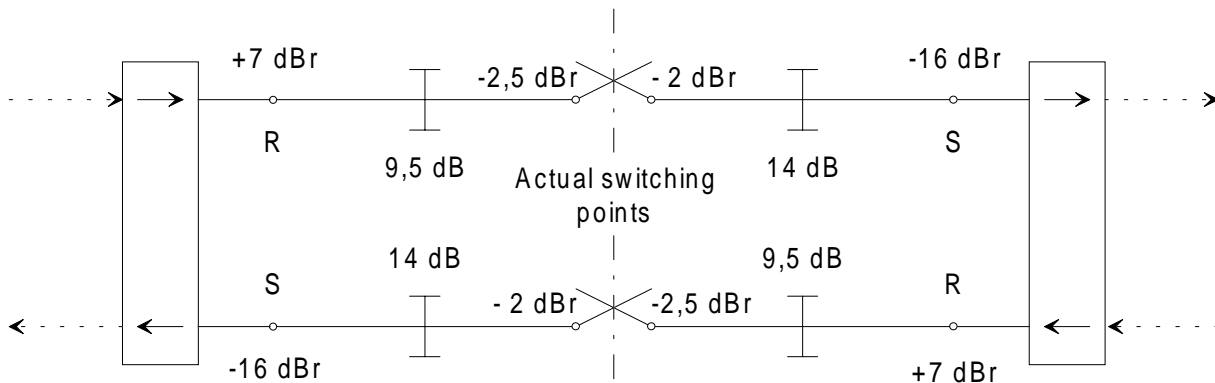

Figure D.11: Example showing a (simplified) representation of a transit connection in an international exchange, actual arrangement

Occasionally, the transmission planner may find it convenient to assign a "level-jump" at an interface between a public and a private circuit which is not associated with switching (such a level-jump minimizes the dynamic range and should be as small as possible).

Note that, in general, the total loss of a connection made up of several circuits should be determined by adding the losses of the individual circuits, and not by taking differences in relative levels between the input and the output of the connection ports (the latter method is only valid when all the consistent circuits are digital and not using digital signal processing).

With regard to digital parameters in a complete connection, the transmission planner should also consider the sum of q_{du} 's, the total amount of digital loss or gain introduced, and the sum of all level-jumps (see clause D.2).

Annex E (informative): Impedances and relative levels used up to now by the various European administrations

The corresponding values for the various L2, K2, M2, and M4 interfaces are listed in tables E.1 to E.4, respectively. The configuration of the PBX input impedance and of the test network for trans balance return loss is given in figure E.1.

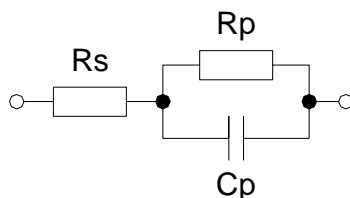

Figure E.1: Configuration of the PBX Input Impedance and the Test Network for TBRL

Table E.1: L2 interface - Values for impedance, the test network for TBRL, and the relative input and output levels specified by different administrations

Country	PBX Input Impedance			Test Network for Terminal Balance Return Loss			Relative Input/output levels	
	R_s [Ω]	R_p [Ω]	C_p [nF]	R_s [Ω]	R_p [Ω]	C_p [nF]	L_i [dBr]	L_o [dBr]
Austria	220 600	820 0	115 0	600 600	0 0	0 0	0 0	-7 -7
Belgium								
short lines ≤ 2,5 km	150	830	72	600	0	0	0	-7
long lines > 2,5 km	150	830	72	150	830	72	0	-7
Denmark	300	1 000	220	400	500	330	0	-6
Finland	270 270	910 910	120 120	390 270	620 1200	100 120	0 0	-7 -7
France ¹⁾	215 (180)	1 000 (910)	137 (150)	600 600	0 0	0 0	-1,9 (-1,4)	-8,9 (-8,4)
Germany								
option	220 220	820 820	115 115	220 220	820 820	115 115	0 +3	-7 -10
Greece	400	500	50	220	820	115	0	-7
Italy	180	630	60	0	750	18	0	-7
Netherlands		NS		340	422	100	0	-7
Norway ²⁾	120 120	820 820	110 110	120 120	820 820	110 110	+2 +7	-5 -11
Portugal		NS			NS		under study	
Slovakia	220 600	820 0	115 0	220 600	820 0	115 0	0 +3	-7 -10
Spain	220	820	120	220	820	120	0	-7
Sweden ³⁾	200	1 000	100	0	900	30	0	-5
Switzerland	220	820	115	220	820	115	0	-6,5
UK (BT)	300	1 000	220	370	620	310	≥ +3	NS

NOTE 1: Values in brackets shall not be used in the future.
 NOTE 2: In Norway, for connections to/from digital exchange lines, the relative levels may have to be changed to $L_o = -11$ dBr and $L_i = +7$ dBr to satisfy the recommendations in ETR 004 [1].
 NOTE 3: On international connections 2 dB digitally implemented loss is added at the international switching centre in the receiving transmission direction.

Table E.2: K2 interface - Values for impedance, the test network for TBRL, and the relative input and output levels specified by different administrations

Country	PBX Input impedance			Test network for Terminal Balance Return Loss			Relative input/output levels		
	R_s [Ω]	R_p [Ω]	C_p [nF]	R_s [Ω]	R_p [Ω]	C_p [nF]	L_i [dBr]	L_o [dBr]	
Austria ¹⁾	220 600	820 0	115 0	220 220	1200 1200	150 150	-6	-1	
Belgium	line \leq 3 dB line $>$ 3 dB	150 150	830 830	72 72	150 176 ²⁾	830 873 ²⁾	72 166 ²⁾	-4 -6	-3 -1
Denmark	case a ⁸⁾ case b ⁸⁾	400 400	500 500	330 330	270 300	390 1 000	91 220	-3 6	-3 0
Finland	line \leq 1 km line $>$ 1 km	600 270	0 910	0 120	390 270	620 1200	100 120	-4,5 -4,5	-2,5 -2,5
France	line \leq 2 dB line $>$ 2 dB	215	1 000 or (910)	137 (150)	215 (180)	1 000 or (910)	137 (150)	-4,9 -7,9	-5,9 -2,9
a) ³⁾	line \leq 2 dB line $>$ 2 dB	(180)	(0) or (0)	(0)				(-4,4) (-7,4)	(-5,4) (-2,4)
b) ³⁾	line \leq 2 dB line $>$ 2 dB	(600)	(0) or (0)	(0)				(-4,7) (-7,7)	(-5,7) (-2,7)
c) ³⁾	line \leq 2 dB line $>$ 2 dB	(900)	(0)	(0)				(-3) (-6)	(-4) (-1)
Germany	line \leq 2 dB line $>$ 2 dB	220 220	820 820	115 115	220 220	820 820	115 115	-5 -7	-2 0
option	line \leq 2 dB line $>$ 2 dB	220 220	820 820	115 115	220 220	820 820	115 115	-8 -10	+1 +3
Italy		600 600	0 0	0 0	400 400	700 700	200 200	-5 -6 ⁹⁾	-2 -1 ⁹⁾
Netherlands	line \leq 3 dB line $>$ 3 dB	600 600	0 0	0 0	NS			(-4) ⁷⁾ -6	(-3) ⁷⁾ -1
Norway	line \leq 3 dB line $>$ 3 dB	120 120	820 820	110 110	120 120	820 820	110 110	-2 (-4)	-1 (+1)
Portugal		330	910	110	NS			NS	NS
Slovakia	a) ¹⁰⁾ b) ¹⁰⁾ c) ¹⁰⁾	220 220 220	820 820 820	115 115 115	220 220 220	820 820 820	115 115 115	-6 -3 0	-1 -4 -7
Spain	line \leq 3 dB line $>$ 3 dB	220 220	820 820	120 120	220 220	820 820	120 120	-4 (-6)	-3 (-1)
Sweden ⁴⁾		0	900	30	0	900	60	-2	-3
Switzerland	line \leq 2 dB line $>$ 2 dB	220 220	820 820	115 115	220 220	820 820	115 115	-2,5 (-4,5)	-4 (-2)
UK Business Telecom (BT) ⁵⁾	line \leq x km ⁵⁾ line $>$ x km ⁵⁾	370 370	620 620	310 310	600 300	0 1 000	0 220	-11 -3 ⁶⁾	\leq +3 \leq +3

continued

Table E.2 (concluded): K2 interface - Values for impedance, the test network for TBRL, and the relative input and output levels specified by different administrations

NOTE 1:	In order to get a high echo loss in the public network and in the case of subscriber loop with a resistance less than 450Ω , in Austria a 3 dB artificial line (T-pad: $180 \Omega / 100 \text{ nF} / 180 \Omega$) shall be inserted into the subscriber line (K2 interface). Echo depends essentially on the balance impedance and the terminating of the hybrid. In Austria in the case of a short subscriber line, a real impedance on the LE and a complex balance impedance in the K2 interface, the adjustment of the transmission loss shall be made by inserting an artificial line into the subscriber line, instead of changing the relative levels.
NOTE 2:	Option for extra long lines: $1,36 \mu\text{F} + 176 \Omega + (873 \Omega \parallel 166 \text{ nF})$.
NOTE 3:	Main values quoted are for new PBXs. The options a, b, and c are for intermediate values which shall not be used in the future.
NOTE 4:	On international connections 2 dB digitally implemented loss is added at the international switching centre in the receiving transmission direction.
NOTE 5:	The line length, signed by "x" is not specified (BT).
NOTE 6:	In UK the level of Li of the K2 interface depends on the loss of the line.
NOTE 7:	The values -6 and -1 are allowed in both cases. The values -4 and -3 are only allowed for lines $\leq 3 \text{ dB}$.
NOTE 8:	The use of case a or b depends on the length of the subscriber line and the input impedance of the public exchange.
NOTE 9:	For transit-PBX.
NOTE 10:	The use of case a), b) or c) depends on the length of the subscriber line and the input impedance of the public exchange.

Table E.3: M2 interface (M21/M22) - Values for impedance, the test network for TBRL, and the relative input and output levels specified by different administrations

Country	Mode	PBX Input impedance			Test network for Terminal Balance Return Loss			Relative input/output levels				
		R _s [Ω]	R _p [Ω]	C _p [nF]	R _s [Ω]	R _p [Ω]	C _p [nF]	L _i [dBr]	L _o [dBr]			
Austria	M21	200	820	115	220	820	115	0	-7			
	M22	600	0	0				-6 / 0	-1/-7			
Belgium	M2	150	830	72	NS	NS	NS	NS	NS			
Denmark	M21	400	500	330	under study			0	-6			
	M22	400	500	330	under study			under study				
Finland	line ≤ 1 km M21	600	0	0	390	620	100	0	-7			
	line > 1 km M21	270	910	120	270	1 200	120	0	-7			
	line ≤ 1 km M22	600	0	0	390	620	100	NS	NS			
	line > 1 km M22	270	910	120	270	1 200	120	NS	NS			
France	M21				215			-1,9	-8,9			
	a) ¹⁾ M21							1 000		137		(-1,4)
	b) ¹⁾ M21	215	1 000	137								(-7,7)
	c) ¹⁾ M21	or						(0)	(-7)			
	line ≤ 2 dB M22	(180)	(910)	(150)				215	1 000	137	-4,9	-5,9
	line > 2 dB M22	or						or			-7,9	-2,9
	a) ¹⁾ line ≤ 2 dB M22	(600)	(0)	(0)				(180)	(910)	(150)	(-4,4)	(-5,4)
	line > 2 dB M22	or						or			(-7,4)	(-2,4)
	b) ¹⁾ line ≤ 2 dB M22	(900)	(0)	(0)							(-4,7)	(-5,7)
	line > 2 dB M22										(-7,7)	(-2,7)
c) ¹⁾ line ≤ 2 dB M22							(-3)	(-4)				
line > 2 dB M22							(-6)	(-1)				
Germany	M21	220	820	115	220	820	115	0	-7			
	opt: M21	220	820	115	220	820	115	+3	-10			
opt.:	line ≤ 2 dB M22	220	820	115	220	820	115	-5	-2			
	line > 2 dB M22	220	820	115	220	820	115	-7	0			
	line ≤ 2 dB M22	220	820	115	220	820	115	-8	+1			
	line > 2 dB M22	220	820	115	220	820	115	-10	+3			
Italy	M21	600	0	0	400	700	200	0	-7			
	M22	600	0	0	400	700	200	-6	-1			
Netherlands	M21	600	0	0	NS			NS	NS			
	M22	600	0	0	NS			NS	NS			
Norway	M21	120	820	110	120	820	110	+1	-4			
	M22	120	820	110	120	820	110	+1	-4			
Portugal	M2	NS			NS			under study				
Slovakia	a) ⁴⁾ M21	600	0	0	600	0	0	-6	-1			
	b) ⁴⁾ M21	600	0	0	600	0	0	-3	-4			
	c) ⁴⁾ M21	600	0	0	600	0	0	0	-7			
a) ⁴⁾ b) ⁴⁾ c) ⁴⁾	M22	600	0	0	600	0	0	-6	-1			
	M22	600	0	0	600	0	0	-3	-4			
	M22	600	0	0	600	0	0	0	-7			
Spain	M2	NS			NS			NS	NS			
Sweden ²⁾	M21	0	900	30	0	900	30-60	0	-5			
	M22	0	900	30	0	900	30-60	0	-5			

(continued)

Table E.3 (concluded): M2 interface (M21/M22) - Values for impedance, the test network for TBRL, and the relative input and output levels specified by different administrations

Country	Mode	PBX Input impedance			Test network for Terminal Balance Return Loss			Relative input/output levels	
		R_s [Ω]	R_p [Ω]	C_p [nF]	R_s [Ω]	R_p [Ω]	C_p [nF]	L_i [dBr]	L_o [dBr]
Switzerland	M21	220	820	115	220	820	115	0	-6,5
	M22	220	820	115	220	820	115	0	-6,5
UK (BT)	M21	370	620	310	370	620	310	+1	-6
line $\leq x$ km ³⁾	M22	370	620	310	600	0	0	under study	
line $> x$ km ³⁾	M22	370	620	310	300	1 000	220	under study	

NOTE 1: Main values quoted are for new PBXs. The options a, b, and c are for intermediate values which shall not be used in the future.

NOTE 2: On international connections 2 dB digitally implemented loss is added at the international switching centre in the receiving transmission direction.

NOTE 3: The line-length, signed by "x" is not specified (BT).

NOTE 4: The use of case a), b) or c) depends on the length of the subscriber line and the input impedance of the public exchange.

Table E.4: Relative levels for M4 interfaces specified by different administrations

Country	Relative input/output levels	
	L_i [dBr]	L_o [dBr]
Austria	-3,5	-3,5
Denmark	under study	
Finland	-3,5	-3,5
France a) ³⁾	-3,5	-3,5
b) ³⁾	-4,9	-4,9
c) ³⁾	-5,4	-5,4
Germany	-2,5	-4,5
opt: ¹⁾	-3,5	-3,5
Greece	-3,5	-3,5
Italy	-3,5	-3,5
opt: ²⁾	$-14 + A_s$	$+4 - A_r$
Netherlands	under study	
Norway	0	0
Portugal	under study	
Sweden	-3,5	-3,5
Switzerland	-3,5	-3,0
United Kingdom	-4,5	+0,5

NOTE 1: In the case of Private Branch Network (PBN) with no traffic to the public network.

NOTE 2: In the case of connection to FDM systems A_r and A_s are, respectively, the total loss in the receive and send path between FDM systems and the PBX interface.

NOTE 3: These options are for impedance values of:
Option a) 600 Ω ;
Option b) 180 Ω +910 Ω || 150 nF;
Option c) 215 Ω +1 000 Ω || 137 nF.

Annex F (informative): Bibliography

- I-ETS 300 003 (1991): "Business Telecommunications (BT); Transmission characteristics of digital Private Automatic Branch Exchanges (PABXs)".
- I-ETS 300 004 (1991): "Business Telecommunications (BT); Transmission characteristics at 2-wire analogue interfaces of a digital Private Automatic Branch Exchange (PABX)".
- I-ETS 300 005 (1991): "Business Telecommunications (BT); Transmission characteristics at 4-wire analogue interfaces of a digital Private Automatic Branch Exchange (PABX)".
- I-ETS 300 006 (1991): "Business Telecommunications (BT); Transmission characteristics at digital interfaces of a digital Private Automatic Branch Exchange (PABX)".
- ITU-T Recommendation G.100 (1993): "Definitions used in Recommendations on general characteristics of international telephone connections and circuits".
- CCITT Recommendation G.117 (1988): "Transmission aspects of unbalance about earth (definitions and methods)".
- CCITT Fascicle III.3 (Orange Book, 1980) Supplement 13 to the G Series: "Noise at the terminals of battery supply".

History

Document history			
October 1995	Public Enquiry	PE 95:	1995-11-06 to 1996-03-01
September 1996	Vote	V 111:	1996-09-23 to 1996-11-15
December 1996	First Edition		