



**E**UROPEAN  
**T**ELECOMMUNICATION  
**S**TANDARD

**ETS 300 433**

November 1995

---

Source: ETSI TC-RES

Reference: DE/RES-00005

ICS: 33.020

**Key words:** radio, CB, measurement

**Radio Equipment and Systems (RES);  
Double Side Band (DSB) and/or Single Side Band (SSB)  
amplitude modulated Citizens' Band (CB) radio equipment;  
Technical characteristics and methods of measurement**

**ETSI**

European Telecommunications Standards Institute

**ETSI Secretariat**

**Postal address:** F-06921 Sophia Antipolis CEDEX - FRANCE

**Office address:** 650 Route des Lucioles - Sophia Antipolis - Valbonne - FRANCE

**X.400:** c=fr, a=atlas, p=etsi, s=secretariat - **Internet:** secretariat@etsi.fr

Tel.: +33 92 94 42 00 - Fax: +33 93 65 47 16

---

**Copyright Notification:** No part may be reproduced except as authorized by written permission. The copyright and the foregoing restriction extend to reproduction in all media.

© European Telecommunications Standards Institute 1995. All rights reserved.



## Contents

Introduction.....	7
1 Scope .....	9
2 Normative references.....	9
3 Definitions, abbreviations and symbols.....	10
3.1 Definitions .....	10
3.2 Abbreviations .....	10
3.3 Symbols .....	10
4 General.....	11
4.1 Presentation of equipment for testing purposes .....	11
4.2 Mechanical and electrical design.....	11
4.2.1 General.....	11
4.2.2 Controls .....	11
4.2.3 Marking.....	11
4.3 Interpretation of the measurement results.....	11
5 Technical characteristics.....	12
5.1 Common characteristics .....	12
5.1.1 Frequency band.....	12
5.1.2 Carrier frequencies and channel numbers.....	12
5.1.3 Channel spacing.....	12
5.1.4 Multi-channel equipment .....	12
5.1.5 Type of modulation.....	12
5.1.6 Push-to-talk (ptt) and voice activated switch.....	13
5.1.7 Combination with other equipment.....	13
5.2 Transmitter parameter limits.....	13
5.2.1 Frequency error.....	13
5.2.2 Transmitter Radio Frequency (RF) power.....	13
5.2.3 Adjacent channel power .....	13
5.2.4 Spurious emissions of the transmitter .....	14
5.2.5 Transient frequency behaviour of the transmitter.....	14
5.2.6 Synthesisers .....	15
5.3 Receiver parameter limits .....	15
5.3.1 Maximum usable sensitivity.....	15
5.3.2 Adjacent channel selectivity .....	15
5.3.3 Intermodulation response rejection .....	15
5.3.4 Spurious radiation .....	15
5.3.5 Spurious response rejection.....	16
6 Test conditions, power sources and ambient temperatures .....	16
6.1 Normal and extreme test conditions .....	16
6.2 Test power source .....	16
6.3 Normal test conditions .....	16
6.3.1 Normal temperature and humidity.....	16
6.3.2 Normal test power source .....	17
6.3.2.1 Mains voltage and frequency.....	17
6.3.2.2 Regulated lead-acid battery power sources on vehicles .....	17
6.3.2.3 Other power sources .....	17
6.4 Extreme test conditions .....	17
6.4.1 Extreme temperatures.....	17
6.4.2 Extreme test source voltages.....	17
6.4.2.1 Mains voltage.....	17
6.4.2.2 Regulated lead-acid battery power sources on vehicles .....	17
6.4.2.3 Power sources using other types of battery.....	17

	6.4.2.4	Other power sources.....	17
6.5		Procedure for tests at extreme temperatures .....	18
7		General conditions.....	18
7.1		Arrangements for test signals applied to the receiver input .....	18
7.2		Receiver mute or squelch facility.....	18
7.3		Receiver rated audio output power .....	18
7.4		Transmitter rated RF power .....	18
7.5		Normal test modulation .....	18
	7.5.1	DSB modulation.....	18
	7.5.2	SSB modulation .....	19
7.6		Artificial antenna.....	19
7.7		Test fixture .....	19
7.8		Arrangement for test signals at the input of the transmitter .....	20
7.9		Test site and general arrangements for radiated measurements .....	20
8		Method of measurement for transmitter parameters.....	20
8.1		Frequency error.....	20
	8.1.1	Definition.....	20
	8.1.2	Method of measurement.....	20
8.2		Transmitter RF power .....	20
	8.2.1	Definition.....	20
	8.2.2	Method of measurement (for equipment other than equipment with integral antenna only) .....	21
	8.2.3	Method of measurement for equipment with integral antenna .....	21
8.3		Adjacent channel power.....	22
	8.3.1	Definition.....	22
	8.3.2	Method of measurement.....	22
8.4		Spurious emissions .....	22
	8.4.1	Definition.....	22
	8.4.2	Method of measuring the power level in a specified load, (subclause 8.4.1, a)) .....	23
	8.4.3	Method of measuring the effective radiated power, (subclause 8.4.1 b)).....	23
	8.4.4	Method of measuring the effective radiated power, (subclause 8.4.1 c)).....	24
8.5		Transient frequency behaviour of the transmitter.....	24
	8.5.1	Definitions .....	24
	8.5.2	Method of measurement.....	25
9		Methods of measurement for receiver parameters .....	26
9.1		Maximum usable sensitivity.....	27
	9.1.1	Definition.....	27
	9.1.2	Method of measurement.....	27
9.2		Adjacent channel selectivity .....	27
	9.2.1	Definition.....	27
	9.2.2	Method of measurement.....	27
9.3		Inter-modulation response rejection.....	28
	9.3.1	Definition.....	28
	9.3.2	Method of measurement.....	28
9.4		Spurious radiation .....	28
	9.4.1	Definition.....	28
	9.4.2	Method of measuring the power level in a specified load, (subclause 9.4.1 a)) .....	29
	9.4.3	Method of measuring the effective radiated power, (subclause 9.4.1 b)).....	29
	9.4.4	Method of measuring the effective radiated power, (subclause 9.4.1 c)).....	30
9.5		Spurious response rejection.....	30
	9.5.1	Definition.....	30
	9.5.2	Method of measurement.....	30
10		Measurement uncertainty .....	30
Annex A (normative):		Radiated measurement .....	32
A.1		Test sites and general arrangements for measurements involving the use of radiated fields .....	32

A.1.1	Outdoor test site.....	32
	A.1.1.1 Test site for hand-portable stations.....	32
A.1.2	Test antenna.....	33
A.1.3	Substitution antenna.....	33
A.1.4	Optional additional indoor site.....	34
A.2	Guidance on the use of radiation test sites.....	34
	A.2.1 Measuring distance.....	35
	A.2.2 Test antenna.....	35
	A.2.3 Substitution antenna.....	35
	A.2.4 Artificial antenna.....	35
	A.2.5 Auxiliary cables.....	35
A.3	Further optional alternative indoor test site using an anechoic chamber.....	35
	A.3.1 Example of the construction of a shielded anechoic chamber.....	35
	A.3.2 Influence of parasitic reflections in anechoic chambers.....	36
	A.3.3 Calibration of the shielded anechoic chamber.....	37
Annex B (normative):	Specification for adjacent channel power measurement arrangements.....	39
B.1	Power measuring receiver specification.....	39
	B.1.1 IF filter.....	39
	B.1.2 Variable attenuator.....	40
	B.1.3 Rms value indicator.....	40
	B.1.4 Oscillator and amplifier.....	40
History.....		41

Blank page

## Foreword

This European Telecommunication Standard (ETS) was produced by the Radio Equipment and Systems (RES) Technical Committee of the European Telecommunications Standards Institute (ETSI).

Every ETS prepared by ETSI is a voluntary standard. This ETS contains text concerning the type approval of equipment to which it relates. This text does not make this ETS mandatory in its status as a standard. However, this ETS can be referenced, wholly or in part, for mandatory application by decisions of regulatory bodies.

Transposition dates	
Date of adoption of this ETS:	29 September 1995
Date of latest announcement of this ETS (doa):	28 February 1996
Date of latest publication of new National Standard or endorsement of this ETS (dop/e):	31 August 1996
Date of withdrawal of any conflicting National Standard (dow):	31 August 1996

The national regulations on Citizens' Band (CB) equipment that permit the use of other types of modulation or power levels will not necessarily be affected by the adoption of this ETS.

## Introduction

This ETS is intended to specify the minimum performance and the methods of measurement of CB Double Side Band (DSB) and/or Single Side Band (SSB) amplitude modulated radio equipment as specified in the Scope.

Clause 5 provides the corresponding limits. These limits have been chosen to ensure an acceptable grade of service and to minimise harmful interference to other equipment and services.

Administrative arrangements (e.g. for type approval, marking, antennas), and conditions for the use of CB DSB and/or SSB amplitude modulated radios are to be determined by the national regulatory authorities.

This ETS may be used by European notified accredited test laboratories for the assessment of the performance of the equipment. In order to avoid any ambiguity in that assessment, this standard contains instructions for the presentation of equipment for type testing purposes (clause 4), conditions (clauses 6 and 7) and measurement methods (clauses 8 and 9).

This standard was drafted on the assumption that:

- a) the type test measurements would be performed only once in one of the accredited test laboratories, and then accepted by the various authorities in order to obtain type approval;
- b) if equipment available on the market is required to be checked it should be tested in accordance with the methods specified in this ETS.

Blank page



## 1 Scope

This European Telecommunications Standard (ETS) applies to Double Side Band (DSB) and/or Single Side Band (SSB) amplitude modulated Citizen's Band (CB) radio equipment operating in the frequency band 26,960 MHz to 27,410 MHz with a channel spacing of 10 kHz, and intended for analogue speech and/or data transmission.

This ETS covers the minimum characteristics considered necessary in order to make the best use of the available frequencies. It does not necessarily include all the characteristics that may be required by a user, nor does it necessarily represent the optimum performance achievable.

This ETS covers base stations, mobile stations and two categories of hand-portable stations.

This ETS is complementary to ETS 300 135 [1] which concerns angle modulated CB radio equipment (CEPT PR 27).

Any CB equipment covered by this ETS that can also work with angle modulation is also required to meet ETS 300 135 [1].

This ETS is based upon existing national standards.

This ETS applies to equipment with a socket for an external antenna and to equipment with an integral antenna.

In the case of equipment that is intended for use with either an integral antenna or an external antenna, the equipment is specified to be measured as equipment intended for use with an external antenna and specified to meet the appropriate limits. In addition to this the following characteristics of the transmitter and receiver are specified to be measured as for equipment for use with an integral antenna and the appropriate limits are defined:

- transmitter carrier power;
- spurious emissions of the transmitter;
- spurious radiation of the receiver.

## 2 Normative references

This ETS incorporates, by dated or undated reference, provisions from other publications. These normative references are cited at the appropriate places in the text and relate to the publications listed hereafter. For dated references, subsequent amendments to or revisions of any of these publications apply to this standard only when incorporated in it by amendment or revision. For undated references, the latest edition of the publication referred to applies.

- [1] ETS 300 135 (1991): "Radio Equipment and Systems (RES); Angle-modulated Citizens' Band radio equipment (CEPT PR 27 Radio Equipment). Technical characteristics and methods of measurement".
- [2] CISPR Publication No 16-1 (1993): "Specification for radio disturbance and immunity measuring apparatus and methods; Part 1: Radio disturbance and immunity measuring apparatus".
- [3] CCITT Recommendation O.41 (1988): "Psophometer for use on telephone-type circuits".
- [4] ETR 028 (1992): "Radio Equipment and Systems (RES); Uncertainties in the measurement of mobile radio equipment characteristics".

### 3 Definitions, abbreviations and symbols

#### 3.1 Definitions

For the purposes of this ETS, the following definitions apply:

**base station:** Equipment fitted with an antenna socket, for use with an external antenna, and intended for use in a fixed location.

**mobile station:** Mobile equipment fitted with an antenna socket, for use with an external antenna, normally used in a vehicle or as a transportable station.

**hand-portable station:** Equipment fitted either with an antenna socket, an integral antenna, or both, normally used on a stand-alone basis, to be carried on a person or held in the hand.

**integral antenna:** An antenna designed to be connected to the equipment without the use of a 50  $\Omega$  external connector and considered to be part of the equipment. An integral antenna may be fitted internally or externally to the equipment.

**Double Side Band (DSB) modulation:** DSB amplitude modulation (A3E).

**Single Side Band (SSB) modulation:** SSB amplitude modulation with suppressed carrier (J3E), using the Upper Side Band (USB) or the Lower Side Band (LSB).

#### 3.2 Abbreviations

For the purposes of this ETS, the following abbreviations apply:

ac	alternating current
A3E	DSB amplitude modulation
CB	Citizens' Band
dBA	relative sound level in dB incorporating A-weighting curve
DSB	Double Side Band
emf	electro-motive force
IF	Intermediate Frequency
J3E	SSB amplitude modulation with suppressed carrier
LSB	Lower Side Band
PEP	Peak Envelope Power
ptt	push-to-talk
RF	Radio Frequency
rms	root mean square
SINAD	SND/ND
SND/N	(Signal + Noise + Distortion)/(Noise)
SND/ND	(Signal + Noise + Distortion)/(Noise + Distortion)
SSB	Single Side Band
USB	Upper Side Band

#### 3.3 Symbols

For the purposes of this ETS, the following symbols apply:

$E_o$	reference field strength, (see annex A)
$R_o$	reference distance, (see annex A)

## **4 General**

### **4.1 Presentation of equipment for testing purposes**

The manufacturer shall provide a production model of the equipment for type testing.

Tests shall be carried out on the highest and lowest channel within the switching range of the equipment and on a channel near the middle of the switching range. The switching range of the receiver and transmitter shall be declared by the manufacturer.

NOTE: The switching range is the maximum frequency range over which the receiver or the transmitter can be operated without reprogramming or realignment.

In the case of equipment fitted with one channel only, all tests are carried out on that channel.

In the case of equipment fitted with two channels, all tests are carried out on both channels.

### **4.2 Mechanical and electrical design**

#### **4.2.1 General**

The equipment submitted by the manufacturer or his representative, shall be designed, constructed and manufactured in accordance with sound engineering practice, and with the aim to minimise harmful interference to other equipment and services.

#### **4.2.2 Controls**

Those controls which, if maladjusted might increase the interfering potentialities of the equipment or improper functioning of the transceiver, shall not be accessible to the user.

#### **4.2.3 Marking**

The marking shall be in accordance with the requirements of the national regulatory authorities.

### **4.3 Interpretation of the measurement results**

The interpretation of the results recorded in a test report when making the measurements described in this ETS shall be as follows:

- a) the measured value related to the corresponding limit shall be used to decide whether an equipment meets the minimum requirements of this ETS;
- b) the actual measurement uncertainty for each particular measurement shall be included in the test report;
- c) the values, of the actual measurement uncertainty shall be, for each measurement, equal to or less than the figures given in clause 10 (table of measurement uncertainty).

## 5 Technical characteristics

### 5.1 Common characteristics

#### 5.1.1 Frequency band

The maximum operating frequency band shall be from 26,960 MHz to 27,410 MHz. Equipment may operate on one or more channels up to a maximum of 40 channels.

The operating frequency band specified in this ETS is currently allocated for CB equipment in most European countries. This fact does not prevent the upholding of the other 27 MHz frequency bands allocated to CB equipment in some countries, nor future extensions which could be decided by CEPT/ERC or by the national regulatory authorities.

#### 5.1.2 Carrier frequencies and channel numbers.

The allowed carrier frequencies and associated channel numbers are given in table 1. Transmission and reception shall take place on the same channel (single frequency simplex mode).

Table 1: Carrier frequency and channel number

Carrier frequencies (MHz)	Channel number	Carrier frequencies (MHz)	Channel number	Carrier frequencies (MHz)	Channel number
26,965	1	27,135	15	27,295	29
26,975	2	27,155	16	27,305	30
26,985	3	27,165	17	27,315	31
27,005	4	27,175	18	27,325	32
27,015	5	27,185	19	27,335	33
27,025	6	27,205	20	27,345	34
27,035	7	27,215	21	27,355	35
27,055	8	27,225	22	27,365	36
27,065	9	27,235	23	27,375	37
27,075	10	27,245	24	27,385	38
27,085	11	27,255	25	27,395	39
27,105	12	27,265	26	27,405	40
27,115	13	27,275	27		
27,125	14	27,285	28		

#### 5.1.3 Channel spacing

The channel spacing shall be 10 kHz.

#### 5.1.4 Multi-channel equipment

Multi-channel equipment may be used, provided that such equipment is only designed for the channels indicated in subclause 5.1.2.

Precautions shall be taken against extension of the usable frequency range by the user, e.g. the physical and electrical design of the channel switching system shall permit operation in not more than the channels indicated in subclause 5.1.2.

#### 5.1.5 Type of modulation

Equipment only capable of using A3E or J3E shall be tested according to this ETS by using the appropriate type of modulation.

Equipment capable of using both A3E and J3E shall be tested to this ETS in both modes of modulation.

### 5.1.6 Push-to-talk (ptt) and voice activated switch

Switching between the transmit and receive mode of operation shall be by means of a non-locking push-to-talk (ptt) switch or by means of a non-locking voice activated switch. Alternatively, a locking ptt or a locking voice activated switch may be used provided that the transmitter has a time-out of 10 seconds  $\pm$  5 seconds.

If a voice activated switch is used it shall not respond to ambient noise. This may be implemented by a volume threshold control. When this threshold is exceeded, the unit shall switch to transmit mode.

For SSB amplitude modulated CB equipment with a microphone jack, the threshold level adjustment shall be accessible to the user and, for DSB amplitude modulated CB equipment with a microphone jack, the threshold level adjustment may be accessible to the user.

For equipment without a microphone jack, the threshold level shall be fixed at 80 dBA (at 1 kHz).

All adjustment points that have influence on the threshold and are accessible by the user, shall be safe against unintended change of setting.

### 5.1.7 Combination with other equipment

The CB equipment shall not be combined with any other form of transmitting equipment. If it is combined with a receiving equipment, e.g. a car-radio, it shall not be possible to operate the latter during the transmission mode of the CB equipment.

Terminals or other connecting points are permitted for the connection of external devices that shall not modulate the transmitter (e.g. a voice synthesiser device to give an aural indication of the selected channel).

The CB equipment shall not be provided with any terminals or other connection points, internal or external, for modulating sources other than those required for either a separate or a built-in microphone, or for selective calling devices.

Equipment fitted with a selective calling device shall meet the requirements of subclause 5.2.4 with the device in operation.

## 5.2 Transmitter parameter limits

### 5.2.1 Frequency error

For the definition and the measuring method see subclause 8.1.

The frequency error shall not exceed 0,6 kHz.

### 5.2.2 Transmitter Radio Frequency (RF) power

For the definition and the measuring method see subclause 8.2.

Both the transmitter RF power (terminated in 50  $\Omega$ ), and the effective radiated power of an equipment with an integral antenna, shall not exceed the following limits:

- 1 W (carrier power) for DSB amplitude modulated equipment;
- 4 W Peak Envelope Power (PEP) for SSB amplitude modulated equipment.

Any adjustment circuit that may raise the transmitter RF power above these limits shall not be accessible to the user.

### 5.2.3 Adjacent channel power

For the definition and measuring method see subclause 8.3.

The adjacent channel power shall not exceed a value of 20 µW.

#### 5.2.4 Spurious emissions of the transmitter

For the definition and measuring method see subclause 8.4.

The power of conducted and radiated spurious emissions shall not exceed 4 nW for the transmitter operating and 2 nW for the transmitter in the stand-by condition in the following frequency bands:

- 47 MHz to 74 MHz;
- 87,5 MHz to 118 MHz;
- 174 MHz to 230 MHz;
- 470 MHz to 862 MHz.

The power of any spurious emissions on any other frequency in the specified ranges shall not exceed the limits given in tables 2 and 3.

**Table 2: Limits for conducted emissions**

Frequency range	Transmitter operating	Transmitter stand-by
9 kHz to 1 GHz	0,25 µW (- 36 dBm)	2 nW (- 57 dBm)
1 GHz to 2 GHz (or 4 GHz), (see subclause 8.4.2)	1 µW (- 30 dBm)	20 nW (- 47 dBm)

**Table 3: Limits for radiated emissions**

Frequency range	Transmitter operating	Transmitter stand-by
25 MHz to 1 GHz	0,25 µW (- 36 dBm)	2 nW (- 57 dBm)
1 GHz to 2 GHz (or 4 GHz), (see subclause 8.4.3)	1 µW (- 30 dBm)	20 nW (- 47 dBm)

Table 4 should be used for the measurement bandwidth for conducted and radiated measurements.

**Table 4: Measuring bandwidth**

Frequency range	Bandwidth (- 6 dB)
9 kHz to 150 kHz	200 Hz
>150 kHz to 30 MHz	9 kHz to 10 kHz
>30 MHz to 1 GHz	100 kHz to 120 kHz
>1 GHz	1 MHz

The measurement detector used for this measurement should be a peak detector in accordance with CISPR Publication No. 16-1 [2].

In the case of radiated measurements for hand-portable stations the following conditions shall apply:

- for integral antenna equipment the normal antenna shall be connected;
- for equipment with an external antenna socket an artificial load shall be connected to the socket for the test.

#### 5.2.5 Transient frequency behaviour of the transmitter

This measurement applies only to equipment with an external antenna connector.

For the definition and measurement method see subclause 8.5.

The transient periods are shown in subclause 8.5, figure 2, and are as follows:

- $t_1$  5,0 ms;
- $t_2$  20,0 ms;
- $t_3$  5,0 ms.

During the periods  $t_1$  and  $t_3$  the frequency difference shall not exceed the value of one channel separation.

During the period  $t_2$  the frequency difference shall not exceed the value of half a channel separation.

### 5.2.6 Synthesisers

If, for determining the transmitter frequency, use is made of a synthesiser, the transmitter shall be inhibited when synchronisation is absent.

## 5.3 Receiver parameter limits

### 5.3.1 Maximum usable sensitivity

This requirement applies only to equipment with an external antenna connector.

For the definition and measuring method see subclause 9.1.

The maximum usable sensitivity shall not exceed an electro motive force (emf) of + 12 dB $\mu$ V for DSB equipment and + 6 dB $\mu$ V for SSB equipment.

### 5.3.2 Adjacent channel selectivity

This requirement applies only to equipment with an external antenna connector.

For the definition and measuring method see subclause 9.2.

The adjacent channel selectivity shall not be less than 60 dB.

### 5.3.3 Intermodulation response rejection

This requirement applies only to equipment with an external antenna connector.

For the definition and measurement method see subclause 9.3.

The intermodulation response rejection ratio shall not be less than 48 dB.

### 5.3.4 Spurious radiation

For the definition and the measurement method see subclause 9.4.

The power of any spurious radiation shall not exceed the values in tables 5 and 6.

**Table 5: Limits for conducted emissions**

Frequency range	Limit
9 kHz to 1 GHz	2 nW (- 57 dBm)
1 GHz to 2 GHz (or 4 GHz), (see subclause 9.4.2)	20 nW (- 47 dBm)

Table 6: Limits for radiated emissions

Frequency range	Limit
25 MHz to 1 GHz	2 nW (- 57 dBm)
1 GHz to 2 GHz (or 4 GHz), (see subclause 9.4.3)	20 nW (- 47 dBm)

### 5.3.5 Spurious response rejection

This requirement applies only to equipment with an external antenna connector.

For the definition and the measurement method see subclause 9.5.

At any frequency separated from the nominal frequency of the receiver by more than two channels, the spurious response rejection ratio shall not be less than 48 dB.

## 6 Test conditions, power sources and ambient temperatures

### 6.1 Normal and extreme test conditions

Type tests shall be made under normal test conditions and also, where stated, under extreme test conditions.

In the case of an equipment that can operate also in angle modulation (see ETS 300 135 [1]), the tests under normal conditions shall be performed at the same time for all types of modulation. The tests under extreme conditions shall then be performed at the same time for all types of modulation.

### 6.2 Test power source

During type tests the power source of the equipment shall be replaced by a test power source capable of producing normal and extreme test voltages as specified in subclauses 6.3.2 and 6.4.2.

The internal impedance of the test power source shall be low enough for its effect on the test results to be negligible.

For the purpose of tests, the voltage of the power source shall be measured at the input terminals of the equipment.

If the equipment is provided with a permanently connected power cable, the test voltage shall be that measured at the point of connection of the power cable to the equipment.

For battery operated equipment, the battery shall be removed and the test power source shall be applied as close to the battery terminals as practicable.

During tests the power source voltages shall be maintained within a tolerance of  $\pm 3\%$  relative to the voltage at the beginning of each test.

### 6.3 Normal test conditions

#### 6.3.1 Normal temperature and humidity

The normal temperature and humidity conditions for tests shall be any convenient combination of temperature and humidity within the following ranges:

- temperature: + 15°C to + 35°C;
- relative humidity: 20 % to 75 %.

When it is impracticable to carry out the tests under the conditions stated above, a note to this effect, stating the actual temperature and relative humidity during the tests, shall be added to the test report.



### **6.3.2 Normal test power source**

For the purpose of this ETS, the nominal voltage shall be the declared voltage or any of the declared voltages for which the equipment is designed.

#### **6.3.2.1 Mains voltage and frequency**

The normal test voltage for equipment to be connected to the mains shall be the nominal mains voltage.

The frequency of the test power source corresponding to the mains alternating current (ac) shall be between 49 and 51 Hz.

#### **6.3.2.2 Regulated lead-acid battery power sources on vehicles**

When the radio equipment is intended for operation from the usual types of regulated lead-acid battery power source of vehicles, the normal test voltage shall be 1,1 times the nominal voltage of the battery (6 V, 12 V etc.).

#### **6.3.2.3 Other power sources**

For operation from other power sources or types of battery (primary or secondary), the normal test voltage shall be that declared by the equipment manufacturer.

### **6.4 Extreme test conditions**

#### **6.4.1 Extreme temperatures**

For tests at extreme temperatures, measurements shall be made in accordance with the procedures specified in subclause 6.5, at the upper and lower temperatures of - 10°C and + 55°C respectively.

#### **6.4.2 Extreme test source voltages**

##### **6.4.2.1 Mains voltage**

The extreme test voltage for equipment to be connected to an ac mains source shall be the nominal voltage  $\pm 10\%$ .

##### **6.4.2.2 Regulated lead-acid battery power sources on vehicles**

When the equipment is intended for operation from the usual types of regulated lead-acid battery power sources of vehicles the extreme test voltages shall be 1,3 and 0,9 times the nominal voltage of the battery (6 V, 12 V etc.).

##### **6.4.2.3 Power sources using other types of battery**

The lower extreme test voltages for equipment with power sources using the following batteries shall be:

- for the Leclanché, or the lithium type of battery, 0,85 times the nominal voltage of the battery;
- for the mercury or nickel-cadmium type of battery, 0,9 times the nominal voltage of the battery.

No upper extreme test voltages apply.

##### **6.4.2.4 Other power sources**

For equipment using other power sources, or capable of being operated from a variety of power sources, the extreme test voltages shall be those agreed between the equipment manufacturer and the testing laboratory and shall be recorded in the test report.

## 6.5 Procedure for tests at extreme temperatures

Before measurements are made the equipment shall have reached thermal balance in the test chamber. If the thermal balance is not checked by measurements, a temperature stabilising period of at least one hour, or such period as may be decided by the testing laboratory, shall be allowed. The equipment shall be switched off during the temperature stabilising period.

The sequence of measurements shall be chosen, and the humidity content in the test chamber shall be controlled so that excessive condensation does not occur.

For tests at the upper extreme temperature the equipment shall be placed in the test chamber and left until thermal balance is attained. The equipment shall then be switched on for one minute in the transmit condition, followed by four minutes in the receive condition, after which the equipment shall meet the specified requirements.

For tests at the lower extreme temperature the equipment shall be left in the test chamber until thermal balance is attained, then switched to the standby or receive condition for one minute after which the equipment shall meet the specified requirements.

## 7 General conditions

### 7.1 Arrangements for test signals applied to the receiver input

Sources of test signals for application to the receiver input shall be connected in such a way that the impedance presented to the receiver input is 50  $\Omega$ . This requirement shall be met irrespective of whether one or more signals are supplied to the receiver simultaneously.

The levels of the test signals shall be expressed in terms of the emf at the receiver input terminals.

The effects of any inter-modulation products and noise produced in the signal generators should be negligible.

### 7.2 Receiver mute or squelch facility

If the receiver is equipped with a mute or squelch circuit, this shall be made inoperative for the duration of the type approval tests.

### 7.3 Receiver rated audio output power

The rated audio output power shall be the maximum power, declared by the manufacturer, for which all the requirements of this ETS are met. With normal test modulation (subclause 7.5), the audio power shall be measured in a resistive load, simulating the load with which the receiver normally operates. The value of this load shall be declared by the manufacturer.

### 7.4 Transmitter rated RF power

The rated transmitter RF power shall be the maximum transmitter RF power declared by the manufacturer. The transmitter RF power measured under normal conditions shall be within  $\pm 2$  dB of the rated transmitter RF power.

### 7.5 Normal test modulation

#### 7.5.1 DSB modulation

a) modulation for the transmitter tests:

- the transmitter shall be modulated by a test signal of 1 250 Hz at a level that is 20 dB higher than that required to produce a modulation depth of 60 %;

b) modulation for the receiver tests:

- the modulation shall be at a frequency of 1 kHz and at a level resulting in a modulation depth of 60 %.

### 7.5.2 SSB modulation

a) two tone modulation for transmitter tests:

For the two-tone modulation, two audio frequency generators are required, the signals of which shall be combined and simultaneously available at the microphone input of the unit under test. The generators shall not influence each other.

One of the generators shall be switched off. With the other one, the transmitter shall be modulated as described in subclause 7.5.2 b), but by an audio frequency of 400 Hz.

This generator shall be switched off, and the other one shall then be switched on.

The transmitter shall be modulated as described in subclause 7.5.2 b), but by an audio frequency of 2,5 kHz.

Then both generators shall be switched on.

b) One-tone modulation for transmitter tests:

The transmitter shall be modulated by an audio frequency of 1 kHz.

The normal test modulation level shall be 20 dB higher than the audio frequency level which produces the maximum RF output power declared by the manufacturer.

For the measurement of the frequency error, the normal test modulation level shall be the audio frequency level which produces the maximum RF output power declared by the manufacturer.

c) One-tone modulation for receiver tests:

The unmodulated carrier of the RF test generator shall be adjusted 1 kHz up (for USB) or down (for LSB) in respect to the frequencies given in subclause 5.1.2.

### 7.6 Artificial antenna

Tests on the transmitter shall be carried out with a non-reactive non-radiating load of 50  $\Omega$  connected to the antenna terminals.

Tests on the transmitter requiring the use of a test fixture (see subclause 7.7) shall be performed with a 50  $\Omega$  non-reactive non-radiating load connected to the test fixture.

### 7.7 Test fixture

In the case of equipment intended for use with an integral antenna, the manufacturer may be required to supply a test fixture suitable to allow relative measurements to be made on the submitted sample.

The test fixture shall provide means of making external connection to the audio frequency input and radio frequency output and of replacing the power source by external power supplies.

The test fixture shall provide a 50  $\Omega$  RF terminal at the working frequencies of the equipment.

The performance characteristics of this test fixture under normal and extreme conditions are subject to the approval of the test laboratory.

The characteristics of interest to the test laboratory shall be such that:

- a) the coupling loss shall not be greater than 30 dB;
- b) the variation of coupling loss with frequency shall not cause errors exceeding 2 dB in measurements using the test fixture;
- c) the coupling device shall not include any non-linear elements.

The test laboratory may provide its own test fixture. The test fixture may be replaced by a temporary internal 50  $\Omega$  test point.

### **7.8 Arrangement for test signals at the input of the transmitter**

The transmitter audio frequency modulation signal shall be supplied by a generator applied at the connections of the microphone insert, unless otherwise stated.

### **7.9 Test site and general arrangements for radiated measurements**

For guidance on radiation test sites see annex A. Detailed descriptions of the radiated measurement arrangements are included in this annex.

## **8 Method of measurement for transmitter parameters**

If the unit to be tested is designed to operate in USB and in LSB, each side band has to be measured separately for all points of the performed tests.

### **8.1 Frequency error**

#### **8.1.1 Definition**

The frequency error of the transmitter is the difference between the measured frequency and its nominal value.

#### **8.1.2 Method of measurement**

The carrier frequency shall be measured in DSB without modulation and in SSB with modulation (see subclause 7.5.2 b)), with the transmitter connected to an artificial antenna (see subclause 7.6).

NOTE: When testing in the SSB mode the RF (nominal frequency) is shifted by the modulation frequency, i.e. 1 kHz, and the resulting frequency is displayed.

Equipment with an integral antenna shall be placed in a test fixture (see subclause 7.7) connected to an artificial antenna (see subclause 7.6).

The measurement shall be made under normal test conditions (see subclause 6.3) and repeated under extreme test conditions (subclauses 6.4.1 and 6.4.2 applied simultaneously).

### **8.2 Transmitter RF power**

#### **8.2.1 Definition**

The transmitter power is the power delivered to the artificial antenna during a radio frequency cycle, or in the case of equipment with integral antenna, the effective radiated power in the direction of maximum field strength under specified conditions of measurement (subclause 7.9).

### **8.2.2 Method of measurement (for equipment other than equipment with integral antenna only)**

The transmitter shall be connected to an artificial antenna (subclause 7.6), and the power delivered to this artificial antenna shall be measured.

The measurements shall be made under normal test conditions (subclause 6.3) and extreme test conditions (subclauses 6.4.1 and 6.4.2 applied simultaneously).

In DSB the carrier power without modulation shall be measured.

In SSB with modulation (subclause 7.5.2 a)) the PEP shall be measured by a RF watt-meter with direct reading of the PEP or by a RF power analyser.

### **8.2.3 Method of measurement for equipment with integral antenna**

On a test site selected from annex A the equipment shall be placed on the support in one of the following positions:

- for equipment with an internal antenna, it shall stand so that the axis of the equipment which in its normal use is closest to the vertical, shall be vertical;
- for equipment with a rigid external antennas, the antenna shall be vertical;
- for equipment with a non-rigid external antenna, the antenna shall be extended vertically upwards by a non-conducting support.

The test antenna shall be oriented for vertical polarisation and the length of the test antenna shall be chosen to correspond to the frequency of the transmitter. The output of the test antenna shall be connected to measuring equipment.

The transmitter shall be switched on without modulation in DSB or with modulation (subclause 7.5.2, b)) in SSB. The modulation shall be supplied by a loudspeaker, the connecting wires shall be lead vertically downwards.

The measuring receiver shall be tuned to the frequency of the transmitter under test. The test antenna shall be raised and lowered through the specified height range until a maximum signal level is detected by the measuring receiver.

The transmitter shall then be rotated through 360° in the horizontal plane until the maximum signal level is detected by the measuring receiver.

The maximum signal level detected by the measuring receiver shall be noted.

The transmitter shall be replaced by a substitution antenna as defined in annex A, subclause A.2.3.

The substitution antenna shall be oriented for vertical polarisation and the length of the substitution antenna shall be adjusted to correspond to the frequency of the transmitter.

The substitution antenna shall be connected to a calibrated signal generator.

The input attenuator setting of the measuring receiver shall be adjusted in order to increase the sensitivity of the measuring receiver.

The test antenna shall be raised and lowered through the specified height range to ensure that the maximum signal is received.

The input signal to the substitution antenna shall be adjusted to the level that produces a level detected by the measuring receiver, that is equal to the level noted while the transmitter radiated power was measured, corrected for the change of input attenuator setting of the measuring receiver.

The measurement shall be repeated with the test antenna and the substitution antenna oriented for horizontal polarisation.

The measure of the effective radiated power is the larger of the two power levels recorded, at the input to the substitution antenna, corrected for gain of the antenna if necessary.

### **8.3 Adjacent channel power**

#### **8.3.1 Definition**

The adjacent channel power is that part of the total output power of a transmitter, modulated under defined conditions, which falls within a specified bandwidth centred on the nominal frequency of either of the adjacent channels. This power is the sum of the mean power produced by the modulation process and by residual modulation caused by hum and noise of the transmitter.

#### **8.3.2 Method of measurement**

The adjacent channel power shall be measured with a power measuring receiver that conforms with the requirements given in annex B and is referred to in this clause as the "receiver":

- a) the transmitter RF output power shall be measured (see subclause 8.2) without modulation in DSB or with one tone modulation (see subclause 7.5.2, b)) in SSB;
- b) the output of the transmitter shall be linked to the input of the measuring receiver by a connecting device such that the impedance presented to the transmitter is 50 ohms and the level at the "receiver" input is appropriate;

For the equipment with an integral antenna the connecting device is a test fixture as described in subclause 7.7. With the equipment under normal test conditions (subclause 6.3) the transmitter shall be unmodulated in DSB or shall be modulated with one tone (see subclause 7.5.2 b)) in SSB, the tuning of the "receiver" shall be adjusted so that a maximum response is obtained. This is the 0 dB reference point. The "receiver" variable attenuator setting and the reading of the root mean square (rms) value indicator shall be recorded.

- c) the tuning of the "receiver" shall be adjusted away from the carrier so that the "receiver" 6 dB response nearest to the transmitter carrier frequency is located at a displacement of 5,75 kHz from the nominal carrier frequency;
- d) the transmitter shall be modulated in DSB (see subclause 7.5.1, a)) or shall be modulated with two tones (see subclause 7.5.2, a)) in SSB;
- e) the "receiver" variable attenuator shall be adjusted to obtain the same reading as in step b) or a known relation to it;
- f) the ratio of adjacent channel power to RF power in step a) is the difference between the attenuator settings in steps b) and e), corrected for any differences in the reading of the rms value indicator;
- g) the measurement shall be repeated with the "receiver" tuned to the other side of the carrier;
- h) if the equipment has a microphone socket the measurement shall be repeated with an input level of 1,5 volts at this socket.

### **8.4 Spurious emissions**

#### **8.4.1 Definition**

Spurious emissions are emissions at frequencies other than those of the carrier and sidebands associated with normal test modulation.

The level of spurious emissions shall be measured as:

- a) power level in a specified load (conducted spurious emission); and

- b) their effective radiated power when radiated by the cabinet and structure of the equipment (cabinet radiation); or
- c) their effective radiated power when radiated by the cabinet and the integral antenna, in the case of hand-portable equipment fitted with such an antenna and no external RF connector.

#### **8.4.2 Method of measuring the power level in a specified load, (subclause 8.4.1, a))**

The transmitter shall be connected to a 50  $\Omega$  power attenuator. The output of the power attenuator shall be connected to a measuring receiver.

The transmitter shall be switched on with modulation in DSB (subclause 7.5.1, a)) or with 2-tone modulation in SSB (subclause 7.5.2, a)).

The measuring receiver shall be according to CISPR Publication No 16-1 [2], with a peak detector, and shall be tuned over the frequency range from 9 kHz to 2 GHz (or 4 GHz, see last paragraph in this subclause). The measurement bandwidth below 1 GHz shall be in accordance with CISPR Publication No 16-1 [2] and above 1 GHz, it shall be 1 MHz.

At each frequency at which a spurious component is detected, the power level shall be recorded as the conducted spurious emission level delivered into the specified load, except for the channel on which the transmitter is intended to operate and the adjacent channels.

The measurements shall be repeated with the transmitter on stand-by.

If spurious emissions are detected in the frequency range 1,5 GHz to 2 GHz with a level exceeding 0,1  $\mu$ W (transmitter operating) or 1 nW (transmitter on stand-by), the measurement of spurious emissions shall be extended to the frequency range 2 GHz to 4 GHz.

#### **8.4.3 Method of measuring the effective radiated power, (subclause 8.4.1 b))**

On a test site, selected from annex A, the equipment shall be placed at the specified height on the appropriate support and in the position closest to normal use as declared by the manufacturer.

The transmitter antenna connector shall be connected to an artificial antenna, subclause 7.6.

The test antenna shall be oriented for vertical polarisation and the length of the test antenna shall be chosen to correspond to the instantaneous frequency of the measuring receiver, which shall be according to CISPR Publication No 16-1 [2].

The output of the test antenna shall be connected to a measuring receiver. The transmitter shall be switched on with modulation in DSB (subclause 7.5.1 a)) or with one tone modulation in SSB (subclause 7.5.2 b)). The modulation shall be supplied by an acoustical source. The connecting wires shall be placed leading downwards vertically.

The measuring receiver with a peak detector shall be tuned over the frequency range from 25 MHz to 2 GHz (or 4 GHz, see last paragraph in this subclause). The measurement bandwidth below 1 GHz shall be in accordance with CISPR Publication No 16-1 [2] and above 1 GHz, it shall be 1 MHz.

At each frequency at which a spurious component is detected, the test antenna shall be raised and lowered through the specified range of heights until the maximum signal level is detected on the measuring receiver.

The transmitter shall then be rotated through 360° in the horizontal plane, until the maximum signal level is detected by the measuring receiver.

The maximum signal level detected by the measuring receiver shall be noted.

The transmitter shall be replaced by a substitution antenna as defined in annex A, subclause A.1.3.

The substitution antenna shall be oriented for vertical polarisation and the length of the substitution antenna shall be adjusted to correspond to the frequency of the spurious component detected.

The substitution antenna shall be connected to a calibrated signal generator.

The frequency of the calibrated signal generator shall be set to the frequency of the spurious component detected.

The input attenuator setting of the measuring receiver shall be adjusted in order to increase the sensitivity of the measuring receiver, if necessary.

The test antenna shall be raised and lowered through the specified range of heights to ensure that the maximum signal is received.

The input signal to the substitution antenna shall be adjusted to the level that produces a level detected by the measuring receiver, that is equal to the level noted while the spurious component was measured, corrected for the change of input attenuator setting of the measuring receiver.

The input level to the substitution antenna shall be recorded as power level, corrected for the change of input attenuator setting of the measuring receiver.

The measurement shall be repeated with the test antenna and the substitution antenna oriented for horizontal polarisation.

The value of effective radiated power of the spurious components is the larger of the two power levels recorded for each spurious component at the input to the substitution antenna, corrected for the gain of the antenna if necessary.

If the spurious component exceeds the limit level, the measurement at this frequency shall be repeated with a quasi-peak detector.

The measurements shall be repeated with the transmitter on stand-by.

If spurious emissions are detected in the frequency range 1,5 GHz to 2 GHz with a level exceeding 0,1  $\mu$ W (transmitter operating) or 1 nW (transmitter on stand-by), the measurement of spurious emissions shall be extended to the frequency range 2 GHz to 4 GHz.

#### **8.4.4 Method of measuring the effective radiated power, (subclause 8.4.1 c))**

The method of measurement shall be performed according to subclause 8.4.3, except that the transmitter output shall be connected to the integral antenna and not to an artificial antenna.

### **8.5 Transient frequency behaviour of the transmitter**

#### **8.5.1 Definitions**

The transient frequency behaviour of the transmitter is the variation with respect to time of the transmitter frequency distance from the nominal frequency of the transmitter when the RF output power is switched on and off.

**t<sub>on</sub>**: according to the method of measurement described in subclause 8.5.2 the switch-on instant defined by the condition when the output power, measured at the antenna terminal, exceeds 10 % of the nominal power.

**t<sub>1</sub>**: period of time starting at t<sub>on</sub> and finishing according to subclause 5.2.5.

**t<sub>2</sub>**: period of time starting at end of t<sub>1</sub> and finishing according to subclause 5.2.5.

**t<sub>off</sub>**: switch-off instant defined by the condition when the output power falls below 10 % of the nominal power.

**t<sub>3</sub>**: period of time finishing at t<sub>off</sub> and starting according to subclause 5.2.5.



### 8.5.2 Method of measurement

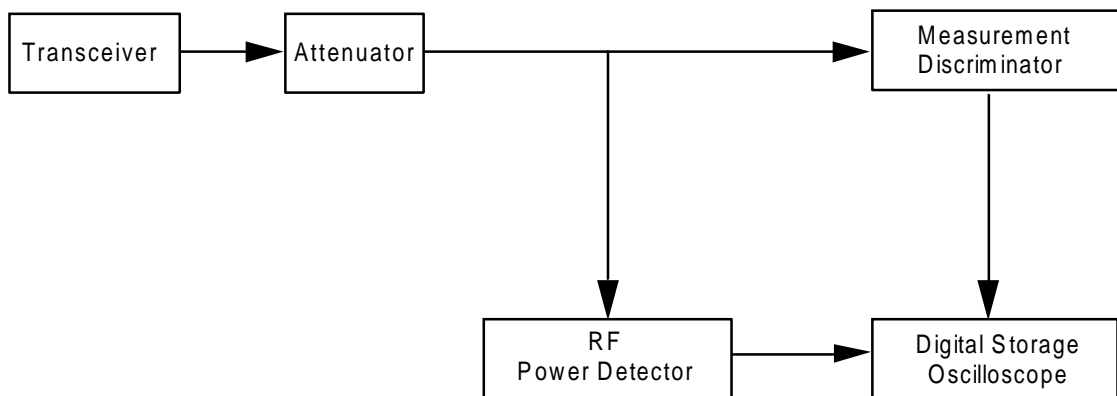

**Figure 1: Measurement arrangement**

The measurement set up shall be assembled according to figure 1, but instead of the transceiver a test signal generator shall be connected. The frequency shall be set to the nominal carrier frequency. The attenuator shall give a termination with correct impedance to the transceiver. It shall be adjusted, so that the limiting amplifier works in the limiting area, when the generator level exceeds the nominal output power of the transceiver by 10 %. The calibration of the test discriminator is checked by setting the test signal generator to a defined frequency deviation.

- a) transient behaviour, switch ON condition;

The trigger threshold on the digital storage oscilloscope shall be set such that it triggers as soon as the level exceeds 10 % of the nominal output power. The oscilloscope shall display the time frame after the point of triggering.

The generator shall be replaced by the transmitter to be tested.

In DSB mode the transmitter is not modulated, in SSB mode the transmitter shall be modulated according to subclause 7.5.2 b). If the transmitter is equipped with a socket for an external microphone, then in SSB mode, the modulating signal shall be present at this socket, even when the transmitter is not switched on.

The transient behaviour is measured by activating the ptt switch.

- b) transient behaviour, switch OFF condition;

The trigger threshold on the digital storage oscilloscope shall be set such, that it triggers, as soon as the level falls below 10 % of the nominal output power. The oscilloscope shall display the time frame before the point of triggering.

In DSB mode the transmitter is not modulated, in SSB mode the transmitter shall be modulated according to subclause 7.5.2 b). If the transmitter is equipped with a socket for an external microphone, then in SSB mode, the modulating signal shall be present at this socket, even when the transmitter is not switched on.

The ptt is activated.

The transient behaviour is measured by releasing the ptt switch.

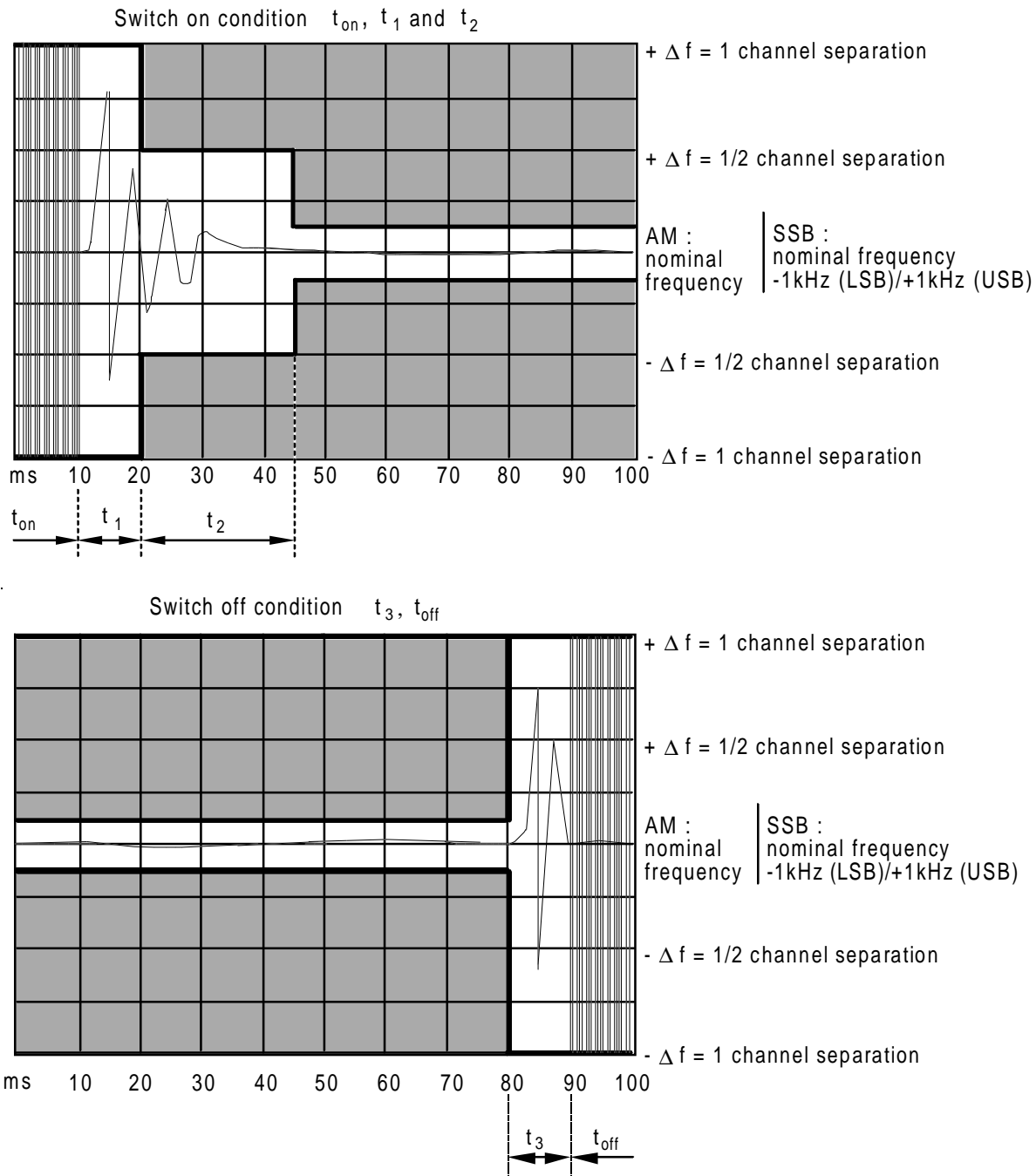

NOTE: The figures shown here are only examples of oscilloscope displays. Refer to subclause 5.2.5 for the actual values of  $t_1$ ,  $t_2$  and  $t_3$ .

**Figure 2: Example storage oscilloscope view  $t_1$ ,  $t_2$  and  $t_3$**

## 9 Methods of measurement for receiver parameters

If the unit to be tested is designed to operate in both the USB and LSB, each sideband has to be measured separately for all the specified tests.

In the case of a hand portable station if requested by the manufacturer, the testing laboratory shall perform all receiver measurements with (Signal + Noise + Distortion)/(Noise) (SND/N) ratio instead of (Signal + Noise + Distortion)/(Noise + Distortion) (SND/ND) ratio.

## 9.1 Maximum usable sensitivity

This measurement applies only to equipment with an external antenna connector.

### 9.1.1 Definition

The maximum usable sensitivity of the receiver is the minimum level of signal (emf) at the receiver input, at the nominal frequency of the receiver and with normal test modulation, (see subclause 7.5), which will produce:

- an audio frequency output power of at least 25 % of the rated power output, (see subclause 7.3); and
- a SND/ND ratio of 20 dB, measured at the receiver output through a telephone psophometric weighting network as described in CCITT Recommendation O.41 [3].

### 9.1.2 Method of measurement

The test signal, at the nominal frequency of the receiver, with normal test modulation (DSB see subclause 7.5.1 b), SSB see subclause 7.5.2 c)) at an emf of 12 dB $\mu$ V (DSB) or 6 dB $\mu$ V (SSB), i.e. the value of the limit for the maximum usable sensitivity, shall be applied to the receiver input connector.

An audio frequency load-resistor, a SND/ND meter and a psophometric telephone weighting network (see subclause 9.1.1), shall be connected to the receiver output terminals. Where possible, the receiver volume control shall be adjusted to give at least 25 % of the rated audio frequency output power, or, in the case of stepped volume controls, to the first step that provides an output power of at least 25 % of the rated audio frequency output power.

The test signal input level shall be reduced until a SND/ND ratio of 20 dB is obtained. The test signal input level under these conditions is the value of the maximum usable sensitivity.

## 9.2 Adjacent channel selectivity

This measurement applies only to equipment with an external antenna connector.

### 9.2.1 Definition

The adjacent channel selectivity is the capability of the receiver to receive a wanted modulated signal at the nominal frequency without exceeding a given degradation due to the presence of an unwanted modulated signal in the adjacent channel.

### 9.2.2 Method of measurement

The two input signals shall be connected to the receiver via a combining network, subclause 7.1.

The wanted test signal, at the nominal frequency of the receiver, with normal test modulation (DSB see subclause 7.5.1 b), SSB see subclause 7.5.2 c)) at an emf of 12 dB $\mu$ V (DSB) or 6 dB $\mu$ V (SSB), i.e. the value of the limit for the maximum usable sensitivity, shall be applied to the receiver input connector via one input of the combining network.

The unwanted test signal, at a frequency of 10 kHz above the nominal frequency of the receiver, frequency modulated with 400 Hz with a deviation of  $\pm 1,2$  kHz shall be applied to the receiver input connector via the second input of the combining network.

The amplitude of the unwanted test signal shall be adjusted until the SND/ND ratio, psophometrically weighted, at the output of the receiver is reduced to 14 dB.

The measure of the adjacent channel selectivity is the ratio in dB of the level of the unwanted test signal to the level of the wanted test signal at the receiver input for which the specified reduction in SND/ND ratio occurs. This ratio shall be noted.

The measurement shall be repeated with an unwanted signal at the frequency of the channel below that of the wanted signal.

The two noted ratios shall be recorded as the upper and lower adjacent channel selectivity.

### **9.3 Inter-modulation response rejection**

This measurement only applies to equipment with an external antenna connector.

#### **9.3.1 Definition**

The inter-modulation response rejection is the capability of a receiver to receive a wanted modulated signal at the nominal frequency without exceeding a given degradation due to the presence of two or more unwanted signals with a specific frequency relationship to the wanted signal frequency.

#### **9.3.2 Method of measurement**

Three input signals shall be connected to the receiver via a combining network, subclause 7.1.

The wanted test signal (A), at the nominal frequency of the receiver, with normal test modulation (DSB see subclause 7.5.1 b), SSB see subclause 7.5.2 c)) at an emf of 12 dB $\mu$ V (DSB) or 6 dB $\mu$ V (SSB), i.e. the value of the limit for the maximum usable sensitivity, shall be applied to the receiver input connector via input of the combining network.

The unwanted test signal (B), at the frequency 20 kHz above the nominal frequency of the receiver, without modulation, shall be applied to the receiver input connector via the second input of the combining network.

The unwanted test signal (C), at a frequency of 40 kHz above the nominal frequency of the receiver, DSB amplitude modulated by 1 kHz to a modulation depth of 60 % shall be applied to the receiver input connector via the third input of the combining network.

The frequency of the unwanted test signals (B) and (C) may be slightly adjusted to search for maximum intermodulation.

The amplitude of the unwanted test signals (B) and (C) shall be maintained equal and adjusted until the SND/ND ratio, psophometrically weighted, at the output of the receiver is reduced to 14 dB.

The measure of the inter-modulation response rejection is the ratio in dB of the level of the unwanted test signals to the level of the wanted test signal at the receiver input for which the specified reduction in SND/ND ratio occurs. This ratio shall be recorded.

The two sets of measurements described above shall be repeated with the unwanted signals below the nominal frequency of the receiver by the specified amounts.

### **9.4 Spurious radiation**

#### **9.4.1 Definition**

Spurious radiation from the receiver are components at any frequency, radiated by the equipment and antenna.

The level of spurious radiation shall be measured by:

- a) their power level in a specified load (conducted spurious emission); and
- b) their effective radiated power when radiated by the cabinet and structure of the equipment (cabinet radiation); or
- c) their effective radiated power when radiated by the cabinet and the integral antenna, in the case of hand-portable equipment fitted with such an antenna and no external RF connector.

#### **9.4.2 Method of measuring the power level in a specified load, (subclause 9.4.1 a))**

The receiver shall be connected to a 50  $\Omega$  attenuator. The output of the attenuator shall be connected to a measuring receiver.

The measuring receiver shall be according to CISPR Publication No 16-1 [2], with a peak detector, and shall be tuned over the frequency range from 9 kHz to 2 GHz (or 4 GHz, see last paragraph in this subclause). The measurement bandwidth below 1 GHz shall be in accordance with CISPR Publication No 16-1 [2] and above 1 GHz, it shall be 1 MHz.

At each frequency at which a spurious component is detected, the power level shall be recorded as the conducted spurious emission level delivered into the specified load.

If spurious radiation is detected in the frequency range 1,5 GHz to 2 GHz with a level exceeding 1 nW, the measurement of spurious emissions shall be extended to the frequency range 2 GHz to 4 GHz.

#### **9.4.3 Method of measuring the effective radiated power, (subclause 9.4.1 b))**

On a test site, selected from annex A, the equipment shall be placed at the specified height on the appropriate support and in the position closest to normal use as declared by the manufacturer.

The receiver antenna connector shall be connected to an artificial antenna, (see subclause 7.6).

The test antenna shall be oriented for vertical polarisation and the length of the test antenna shall be chosen to correspond to the instant frequency of the measuring receiver or the spectrum analyser, which shall be according to CISPR Publication No 16-1 [2].

The output of the test antenna shall be connected to a measuring receiver. The receiver shall be switched on and the measuring receiver with a peak detector shall be tuned over the frequency range from 25 MHz to 2 GHz (or 4 GHz, see last paragraph in this subclause). The measurement bandwidth below 1 GHz shall be in accordance with CISPR Publication No. 16-1 [2], and above 1 GHz the measuring bandwidth shall be 1 MHz.

At each frequency at which a spurious component is detected, the test antenna shall be raised and lowered through the specified height range until a maximum signal level is detected by the measuring receiver. The receiver shall then be rotated through 360° in the horizontal plane until the maximum signal level is detected by the measuring receiver. The maximum signal level detected by the measuring receiver shall be noted.

The receiver shall be replaced by a substitution antenna as defined in annex A, subclause A.2.3. The substitution antenna shall be oriented for vertical polarisation and the length of the substitution antenna shall be adjusted to correspond to the frequency of the spurious component detected. The substitution antenna shall be connected to a calibrated signal generator. The frequency of the calibrated signal generator shall be set to the frequency of the spurious component detected.

The input attenuator setting of the measuring receiver shall be adjusted in order to increase the sensitivity of the measuring receiver, if necessary.

The test antenna shall be raised and lowered through the specified height range to ensure that the maximum signal is received.

The input signal to the substitution antenna shall be adjusted to the level that produces a level noted when the spurious component was measured, corrected for the change of input attenuator setting of the measuring receiver. The input level to the substitution antenna shall be recorded as power level, corrected for the change of input attenuator setting of the measuring receiver.

The measurement shall be repeated with the test antenna and the substitution antenna realigned for horizontal polarisation.

The value of effective radiated power of the spurious components is the larger of the two power levels recorded for each spurious component at the input to the substitution antenna, corrected for the gain of the antenna if necessary.

If spurious radiation is detected in the frequency range 1,5 GHz to 2 GHz with a level exceeding 1 nW, the measurement of spurious emissions shall be extended to the frequency range 2 GHz to 4 GHz.

**9.4.4 Method of measuring the effective radiated power, (subclause 9.4.1 c))**

The measurement shall be performed according to subclause 9.4.3, except that the receiver input shall be connected to the integral antenna and not to an artificial antenna.

**9.5 Spurious response rejection**

This measurement applies only to equipment with an external antenna connector.

**9.5.1 Definition**

The spurious response rejection is the capability of the receiver to discriminate between the wanted modulated signal at the nominal frequency and an unwanted signal at any other frequency at which a response is obtained.

**9.5.2 Method of measurement**

The two input signals shall be connected to the receiver via a combining network, see subclause 7.1.

The wanted test signal, at the nominal frequency of the receiver, with normal test modulation (DSB see subclause 7.5.1 b), SSB see subclause 7.5.2 c)) at an emf of 12 dBµV (DSB) or 6 dBµV (SSB), i.e. the value of the limit for the maximum usable sensitivity, shall be applied to the receiver input connector via one input of the combining network.

The unwanted test signal, DSB amplitude modulated by 1 kHz to a modulation depth of 60 % and at an emf of 92 dBµV, shall be applied to the receiver input connector via the second input of the combining network. The unwanted test signal shall be tuned over the frequency range from 100 kHz to 1 GHz.

At each frequency at which a spurious response occurs, the input level shall be adjusted until the SND/ND ratio, psophometrically weighted, is reduced to 14 dB.

The value of spurious response rejection is the ratio in dB of the level of the unwanted test signal to the level of the wanted test signal at the receiver input for which the specified reduction in SND/ND ratio occurs.

The ratio shall be recorded as the spurious response rejection for each spurious response obtained.

**10 Measurement uncertainty**

**Table 7: Absolute measurement uncertainties**

<b>Absolute measurement uncertainties:</b>	<b>Maximum values</b>
RF frequency	< ± 1x10 <sup>-7</sup>
Audio frequency	< ± 0,1 Hz
RF power	< ± 0,75 dB
Deviation limitation	< ± 5 %
Adjacent channel power	< ± 5 dB
Conducted emission of transmitter	< ± 4 dB
Audio output power	< ± 0,5 dB
Sensitivity at 20 dB SND/ND (SINAD) or SND/N	< ± 3 dB
Conducted emission of receiver	< ± 3 dB
Two-signal measurement, valid to 4 GHz	< ± 4 dB
Three-signal measurement	< ± 3 dB
Radiated emission of transmitter	< ± 6 dB
Radiated emission of receiver	< ± 6 dB
Transmitter transient time	< ± 20 %
Transmitter transient frequency	< ± 250 Hz

For the test methods laid down in this ETS, these uncertainty figures are valid to a confidence level of 95 % calculated according to the methods described in ETR 028 [4].

## **Annex A (normative): Radiated measurement**

### **A.1 Test sites and general arrangements for measurements involving the use of radiated fields**

#### **A.1.1 Outdoor test site**

The outdoor test site shall be on a reasonably level surface or ground. At one point on the site, a ground plane of at least 5 m diameter shall be provided. In the middle of this ground plane, a non-conducting support, capable of rotation through 360° in the horizontal plane, shall be used to support the test sample at 1,5 m above the ground plane. The test site shall be large enough to allow the erection of a measuring or transmitting antenna at a distance of  $\lambda/2$  or 3 m whichever is the greater. The distance actually used shall be recorded with the results of the tests carried out on the site.

Sufficient precautions shall be taken to ensure that reflections from extraneous objects adjacent to the site and ground reflections do not degrade the measurement result.

##### **A.1.1.1 Test site for hand-portable stations**

The test site shall be on a reasonably level surface or ground. The test site shall be large enough to allow the erection of a measuring or transmitting antenna at a distance of at least 6 m. The distance actually used shall be recorded with the results of the test carried out on the site.

At one point on the site, a ground plane of at least 5 m diameter shall be provided. In the middle of this ground plane, a support, capable of rotation through 360° in the horizontal plane, shall be used to support the test sample at 1,5 m above the ground plane. This support consists of a plastic tube, which is filled with salt water (9 g NaCl per litre). The tube shall have a length of 1,5 m and an internal diameter of  $10 \pm 0,5$  cm. The upper end of the tube is closed by a metal plate with a diameter of 15 cm, which is in contact with the water.

The sample shall be placed with its side of largest area on the metal plate. To meet the requirement that the antenna is vertical while maintaining contact with the metal plate, it may be necessary to use a second metal plate, attached to the first. This metal plate shall be 10 cm x 15 cm in size and shall be hinged to the first plate by its 10 cm edge in such a way that the angle between the plates can be adjusted between 0° and 90°. The hinge point shall be adjustable so that the centre of the sample can be placed above the centre of the circular plate. In the cast of samples whose length along the antenna axis is less than 15 cm, the sample shall be arranged so that the base of the antennas is at the edge of the hinged plate.

Sufficient precautions shall be taken to ensure that reflections from extraneous objects adjacent to the site and ground reflections do not degrade the measurement results.



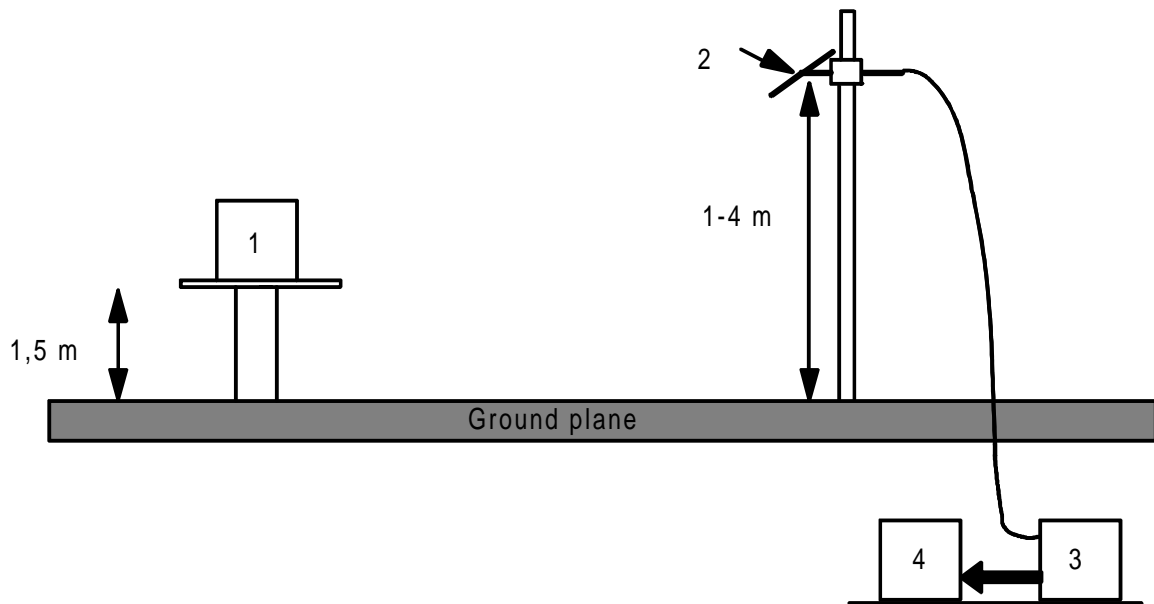

- 1) Equipment under test;
- 2) Test antenna;
- 3) High pass filter (necessary for strong fundamental transmitter radiation);
- 4) Spectrum analyser or measuring receiver.

**Figure A.1: Outdoor test site**

#### **A.1.2 Test antenna**

The test antenna is used to detect the radiation from both the test sample and the substitution antenna, when the site is used for radiation measurements; where necessary, it is used as a transmitting antenna, when the site is used for the measurement of receiver characteristics.

This antenna is mounted on a support such as to allow the antenna to be used in either horizontal or vertical polarisation and for the height of its centre above ground to be varied over the range 1 to 4 m. Preferably a test antenna with pronounced directivity should be used. The size of the test antenna along the measurement axis shall not exceed 20 % of the measuring distance.

For receiver and transmitter radiation measurements, the test antenna is connected to a measuring receiver, capable of being tuned to any frequency under investigation and of measuring accurately the relative levels of signals at its input. For receiver radiated sensitivity measurements the test antenna is connected to a signal generator.

#### **A.1.3 Substitution antenna**

When measuring in the frequency range up to 1 GHz the substitution antenna shall be a  $\lambda/2$  dipole, resonant at the frequency under consideration, or a shortened dipole, calibrated to the  $\lambda/2$  dipole. For measurements between 1 GHz and 4 GHz, either a  $\lambda/2$  dipole or a horn radiator may be used. The centre of this antenna shall coincide with the reference point of the test sample it has replaced. This reference point shall be the volume centre of the sample when its antenna is mounted inside the cabinet, or the point where an external antenna is connected to the cabinet.

The distance between the lower extremity of the dipole and the ground shall be at least 30 cm.

The substitution antenna shall be connected to a calibrated signal generator when the site is used for spurious radiation measurements and transmitter effective radiated power measurements. The substitution antenna shall be connected to a calibrated measuring receiver when the site is used for the measurement of receiver sensitivity.

The signal generator and the receiver shall be operating at the frequencies under investigation and shall be connected to the antenna through suitable matching and balancing networks.

### A.1.4 Optional additional indoor site

When the frequency of the signals being measured is greater than 80 MHz, use may be made of an indoor site. If this alternative site is used, this shall be recorded in the test report.

The measurement site may be a laboratory room with a minimum area of 6m by 7m and at least 2,7 m in height.

Apart from the measuring apparatus and the operator, the room shall be as free as possible from reflecting objects other than the walls, floor and ceiling.

The potential reflections from the wall behind the equipment under test are reduced by placing a barrier of absorbent material in front of it. The corner reflector around the test antenna is used to reduce the effect of reflections from the opposite wall and from the floor and ceiling in the case of horizontally polarised measurements. Similarly, the corner reflector reduces the effects of reflections from the side walls for vertically polarised measurements. For the lower part of the frequency range (below approximately 175 MHz) no corner reflector or absorbent barrier is needed. For practical reasons, the  $\lambda/2$  antenna in figure A.2 may be replaced by an antenna of constant length, provided that this length is between  $\lambda/4$  and  $\lambda$  at the frequency of measurement and the sensitivity of the measuring system is sufficient. In the same way the distance of  $\lambda/2$  to the apex may be varied.

The test antenna, measuring receiver, substitution antenna and calibrated signal generator are used in a way similar to that of the general method. To ensure that errors are not caused by the propagation path approaching the point at which phase cancellation between direct and the remaining reflected signals occurs, the substitution antenna shall be moved through a distance of  $\pm 10$  cm in the direction of the test antenna as well as in the two directions perpendicular to this first direction. If these changes of distance cause a signal change of greater than 2 dB, the test sample should be re-sited until a change of less than 2 dB is obtained.

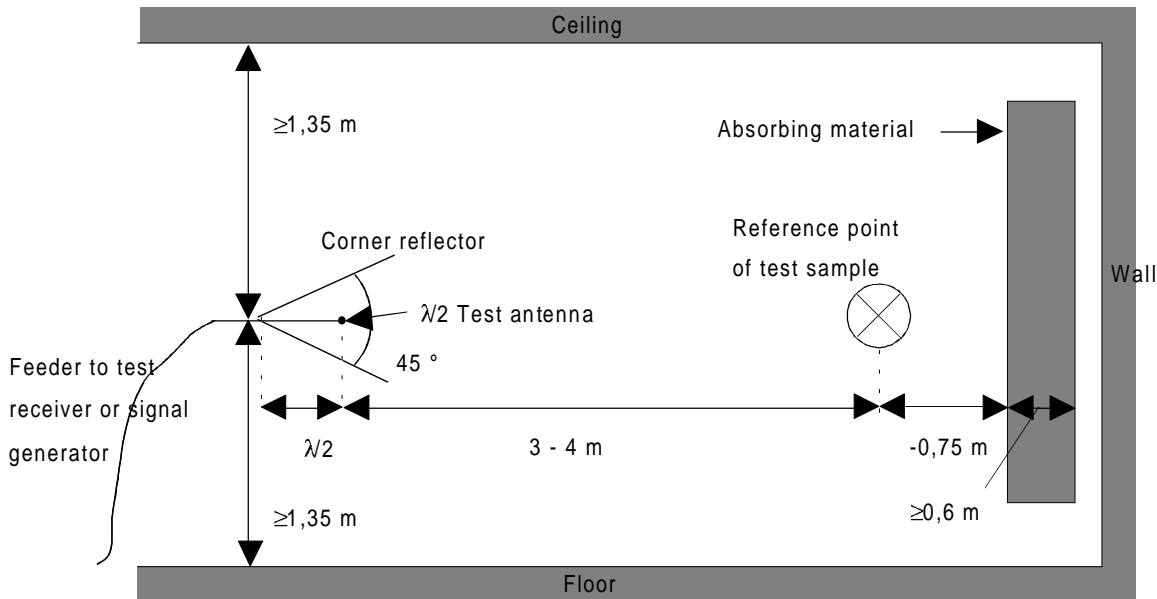

Figure A.2: Indoor site arrangement (shown in horizontal polarisation)

## A.2 Guidance on the use of radiation test sites

For measurements involving the use of radiated fields, use may be made of a test site in conformity with the requirements of Clause A.1 of this annex. When using such a test site, the conditions in the following subclauses should be observed to ensure consistency of measuring results.

### **A.2.1 Measuring distance**

Evidence indicates that the measuring distance is not critical and does not significantly affect the measuring results, provided that the distance is not less than  $\lambda/2$  at the frequency of measurement, and the precautions described in this annex are observed. Measuring distances of 3 m, 5 m, 10 m and 30 m are in common use in European test laboratories.

### **A.2.2 Test antenna**

Different types of test antenna may be used, since performing substitution measurements reduces the effect of the errors on the measuring results.

Height variation of the test antenna over a range of 1 m to 4 m is essential in order to find the point at which the radiation is a maximum.

Height variation of the test antenna may not be necessary at the lower frequencies below about 100 MHz.

### **A.2.3 Substitution antenna**

Variations in the measuring results may occur with the use of different types of substitution antenna at the lower frequencies below about 80 MHz. Where a shortened dipole antenna is used at these frequencies, details of the type of antenna used should be included with the results of the tests carried out on the site. Correction factors shall be taken into account when shortened dipole antennas are used.

### **A.2.4 Artificial antenna**

The dimensions of the artificial antenna used during radiated measurements should be small in relation to the sample under test.

Where possible, a direct connection should be used between the artificial antenna and the test sample.

In cases where it is necessary to use a connecting cable, precautions should be taken to reduce the radiation from this cable by, for example, the use of ferrite cores or double screened cables.

### **A.2.5 Auxiliary cables**

The position of auxiliary cables (power supply and microphone cables, etc.) which are not adequately de-coupled may cause variations in the measuring results. In order to get reproducible results, cables and wires of auxiliaries should be arranged vertically downwards (through a hole in the non conducting support).

## **A.3 Further optional alternative indoor test site using an anechoic chamber**

For radiation measurements when the frequency of the signals being measured is greater than 25 MHz, use may be made of an indoor site being a well-shielded anechoic chamber simulating free space environment. If such a chamber is used, this shall be recorded in the test report.

The test antenna, measuring receiver, substitution antenna and calibrated signal generator are used in a way similar to that of the general method, Clause A.1. In the range between 25 MHz and 100 MHz some additional calibration may be necessary.

An example of a typical measurement site may be an electrically shielded anechoic chamber being 10 m long, 5 m broad and 5 m high. Walls and ceiling should be coated with RF absorbers of 1 m height. The base should be covered with absorbing material 1 m thick, and a wooden floor, able to carry test equipment and operators. A measuring distance of 3 m to 5 m in the long middle axis of the chamber can be used for measurements up to 12,75 GHz. The construction of the anechoic chamber is described in the following clauses.

### **A.3.1 Example of the construction of a shielded anechoic chamber**

Free-field measurements can be simulated in a shielded measuring chamber where the walls are coated with RF absorbers. Figure A.3 shows the requirements for shielding loss and wall return loss of such a

room. As dimensions and characteristics of usual absorber materials are critical below 100 MHz (height of absorbers < 1 m, reflection attenuation < 20 dB) such a room is preferably suitable for measurements above 100 MHz. Figure A.4 shows the construction of a shielded measuring chamber having a base area of 5 m by 10 m and a height of 5 m. Ceilings and walls are coated with pyramidal formed absorbers approximately 1 m high. The base is covered with absorbers that are able to support a form of floor. The available internal dimensions of the room are 3 m x 8 m x 3 m, so that a measuring distance of maximum 5 m length in the middle axis of this room is available.

At 100 MHz the measuring distance can be extended up to a maximum of  $2 \lambda$ . The floor absorbers reject floor reflections so that the antenna height need not be changed and floor reflection influences need not be considered. All measuring results can therefore be checked with simple calculations and the measuring tolerances have the smallest possible values due to the simple measuring configuration.

For special measurements it can be necessary to re-introduce floor reflections. Taking away the floor absorbers would mean a removal of approximately 24 m<sup>3</sup> absorber material. Therefore the floor absorbers are covered with metal plates or metallic nets instead.

### A.3.2 Influence of parasitic reflections in anechoic chambers

For free-space propagation in the far field condition the correlation  $E = E_0(R_0/R)$  is valid for the dependence of the field strength  $E$  on the distance  $R$ , whereby  $E_0$  is the reference field strength in the reference distance  $R_0$ . It is useful to use just this correlation for comparison measurements, as all constants are eliminated with the ratio and neither cable attenuation nor antenna mismatch or antenna dimensions are of importance. Deviations from the ideal curve can be seen easily if the logarithm of the above equation is used, because the ideal correlation of field strength and distance can then be shown as a straight line and the deviations occurring in practice are clearly visible. This indirect method shows the disturbances due to reflections more readily and is far less problematical than the direct measurement of reflection attenuation.

With an anechoic chamber of the dimensions suggested in Clause A.3 at low frequencies up to 100 MHz there are no far field conditions, and therefore reflections are stronger so that careful calibration is necessary. In the medium frequency range from 100 MHz to 1 GHz the dependence of the field strength on the distance meets the expectations very well. In the frequency range of 1 to 12,75 GHz, because more reflections will occur, the dependence of the field strength on the distance will not correlate so closely.

**A.3.3 Calibration of the shielded anechoic chamber**

Careful calibration of the chamber shall be performed over the range 25 MHz to 12,75 GHz.

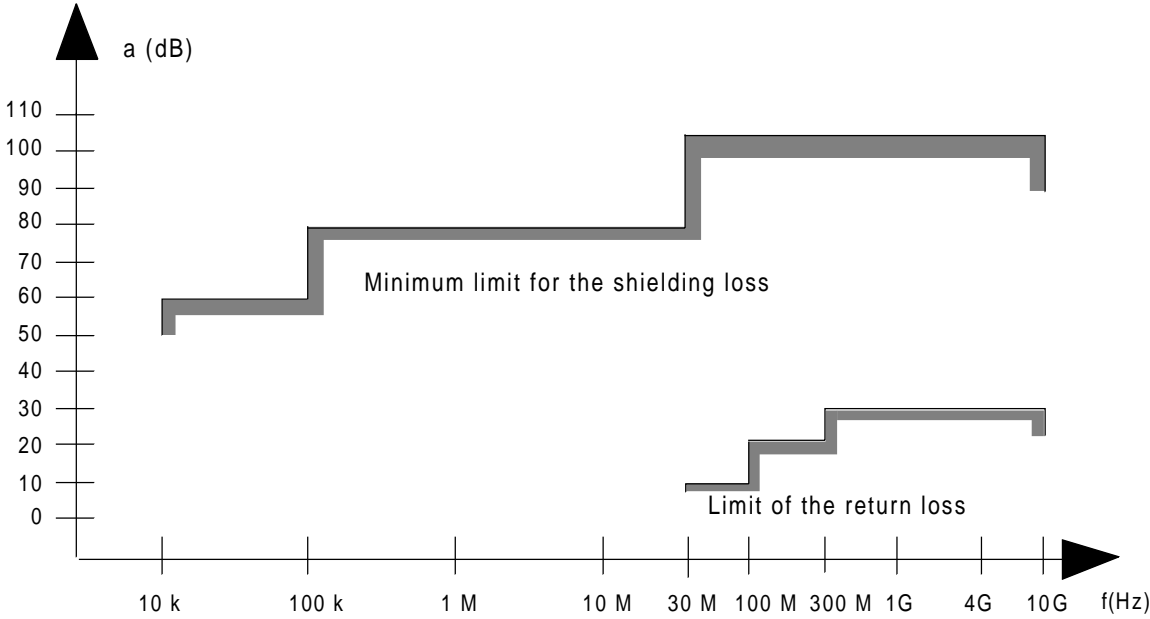

**Figure A.3: Specifications for shielding and reflections**

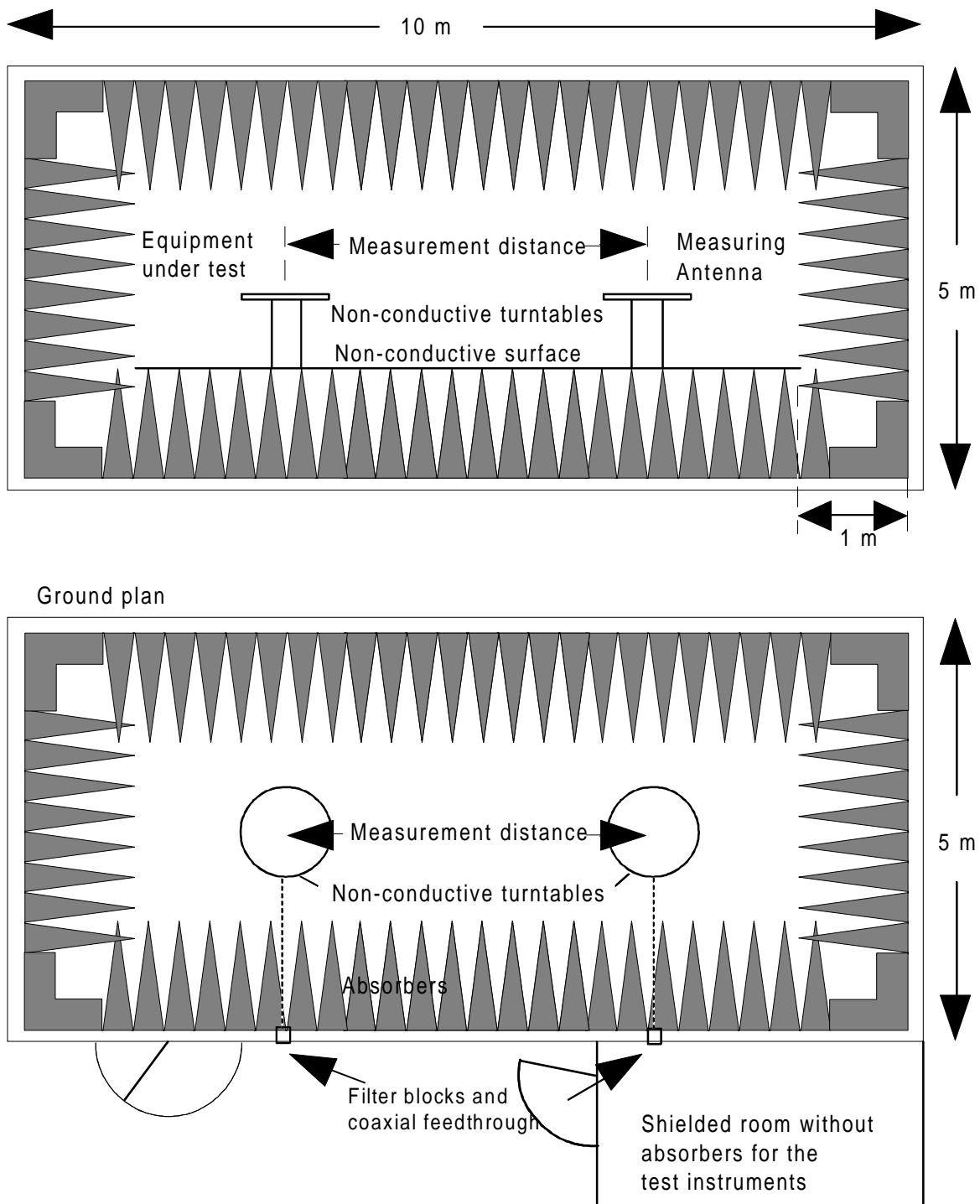

Figure A.4: Example of construction of an anechoic shielded chamber

**Annex B (normative): Specification for adjacent channel power measurement arrangements**

**B.1 Power measuring receiver specification**

The power measuring receiver consists of a mixer, an Intermediate Frequency (IF) filter, an oscillator, an amplifier, a variable attenuator and an rms value indicator. Instead of the variable attenuator with the rms value indicator it is also possible to use an rms voltmeter calibrated in dB as the rms value indicator. The technical characteristics of the power measuring receiver are given in subclauses B.1.1 to B.1.4.

**B.1.1 IF filter**

The IF filter shall be within the limits of the following selectivity characteristic.

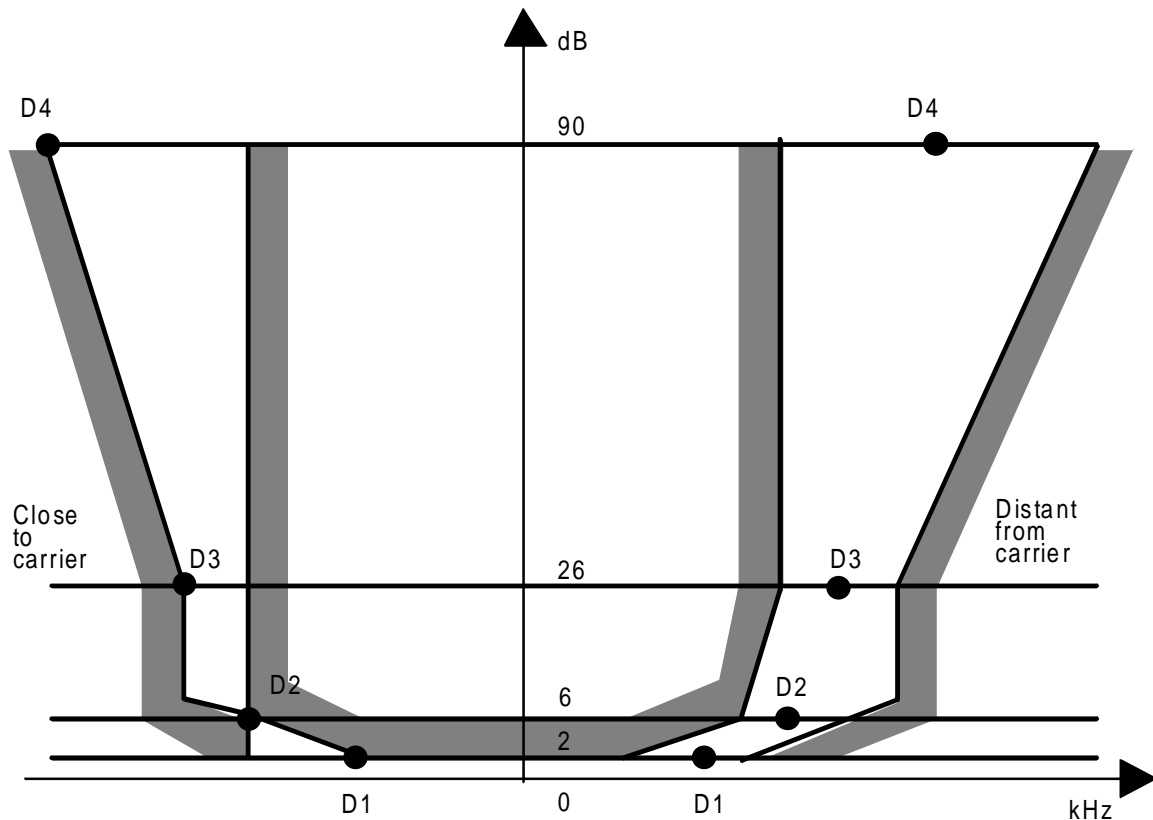

**Figure B.1: IF filter characteristic**

The selectivity characteristic shall keep the frequency separations from the nominal centre frequency of the adjacent channel as given in column 2 of table B.1.

The attenuation points on the slope towards the carrier shall not exceed the tolerances, as given in column 3 of table B.1.

The attenuation points on the slope, distant from the carrier, shall not exceed the tolerances, as given in column 4 of table B.1.

Table B.1: Selectivity characteristics of the "receiver"

Attenuation points	Frequency separation	Tolerance towards C	Tolerance distant from C
D1 (2 dB)	3,00 kHz	+ 1,35 kHz	± 2,00 kHz
D2 (6 dB)	4,25 kHz	± 0,10 kHz	± 2,00 kHz
D3 (26 dB)	5,50 kHz	- 1,35 kHz	± 2,00 kHz
D4 (90 dB)	9,50 kHz	- 5,35 kHz	+ 2 kHz and - 6 kHz

The minimum attenuation of the filter outside the 90 dB attenuation points shall be equal to or greater than 90 dB.

#### B.1.2 Variable attenuator

The attenuation indicator shall have a minimum range of 80 dB and a reading accuracy of 1 dB.

#### B.1.3 Rms value indicator

The instrument shall accurately indicate non-sinusoidal signals in a ratio of up to 10:1 between peak value and rms value.

#### B.1.4 Oscillator and amplifier

The oscillator and the amplifier shall be designed in such a way that the measurement of the adjacent channel power of a low noise unmodulated transmitter, whose self-noise has a negligible influence on the measurement result, yields a measured value of  $\leq - 80$  dB referred to the carrier of the oscillator.



## History

Document history			
July 1994	Public Enquiry	PE 66:	1994-07-04 to 1994-10-28
March 1995	Vote extended:	V 84:	1995-07-24 to 1995-09-15 1995-07-24 to 1995-09-29
November 1995	First Edition		
February 1996	Converted into Adobe Acrobat Portable Document Format (PDF)		