

EUROPEAN
TELECOMMUNICATION
STANDARD

ETS 300 403-7

April 1998

Source: SPS

Reference: DE/SPS-05094

ICS: 33.020

Key words: ISDN, DSS1, layer 3, testing, ATS, PIXIT, network

**Integrated Services Digital Network (ISDN);
Digital Subscriber Signalling System No. one (DSS1) protocol;
Signalling network layer for circuit-mode basic call control;
Part 7: Abstract Test Suite (ATS) and partial Protocol
Implementation eXtra Information for Testing (PIXIT) proforma
specification for the network**

ETSI

European Telecommunications Standards Institute

ETSI Secretariat

Postal address: F-06921 Sophia Antipolis CEDEX - FRANCE

Office address: 650 Route des Lucioles - Sophia Antipolis - Valbonne - FRANCE

Internet: secretariat@etsi.fr - <http://www.etsi.fr> - <http://www.etsi.org>

Tel.: +33 4 92 94 42 00 - Fax: +33 4 93 65 47 16

Copyright Notification: No part may be reproduced except as authorized by written permission. The copyright and the foregoing restriction extend to reproduction in all media.

© European Telecommunications Standards Institute 1998. All rights reserved.

Contents

Foreword	5
1 Scope	7
2 Normative references	7
3 Definitions and abbreviations	8
3.1 Definitions	8
3.2 Abbreviations	8
4 Abstract Test Method (ATM)	9
4.1 Description of ATM used	9
4.2 Conventions for test components and PCOs.....	9
4.3 Conventions for point-to-multipoint configurations.....	11
5 Untestable test purposes.....	11
6 ATS conventions	12
6.1 Declarations part.....	12
6.1.1 Type definitions	12
6.1.1.1 Simple type definitions.....	12
6.1.1.2 Structured type definitions	12
6.1.1.2.1 TTCN structured type definitions	12
6.1.1.2.2 ASN.1 structured type definitions.....	12
6.1.1.3 ASP type definitions.....	12
6.1.1.3.1 TTCN ASP type definitions	12
6.1.1.3.2 ASN.1 ASP type definitions	13
6.1.1.4 PDU type definitions	13
6.1.1.4.1 TTCN PDU type definitions.....	13
6.1.1.4.2 ASN.1 PDU type definitions	13
6.1.2 Test suite constants	13
6.1.3 Test suite parameters	13
6.1.4 Variables	13
6.1.4.1 Test suite variables.....	13
6.1.4.2 Test case variables.....	13
6.1.5 Test suite operation definitions.....	13
6.2 Constraints part.....	14
6.2.1 Structured type constraint declaration	14
6.2.2 ASN.1 type constraint declaration	14
6.2.3 ASP type constraint declaration	14
6.2.3.1 ASN.1 ASP type constraint declaration	14
6.2.3.2 TTCN ASP type constraint declaration	14
6.2.4 PDU type constraint declaration	15
6.2.4.1 ASN.1 PDU type constraint declaration.....	15
6.2.4.2 TTCN PDU type constraint declaration	15
6.2.5 Derived constraints.....	15
6.2.6 Parameterized constraints.....	15
6.2.7 Value assignment.....	15
6.2.7.1 Specific values.....	15
6.2.7.2 Matching values.....	15
6.3 Dynamic part.....	15
6.3.1 Test cases.....	15
6.3.2 Test steps.....	15
6.3.3 Defaults	15
7 ATS to TP map.....	15

8	PCTR conformance	16
9	PIXIT conformance.....	16
10	ATS conformance.....	16
	Annex A (normative): Protocol Conformance Test Report (PCTR) proforma	17
A.1	Identification summary.....	17
A.1.1	Protocol conformance test report.....	17
A.1.2	IUT identification.....	17
A.1.3	Testing environment.....	17
A.1.4	Limits and reservations	18
A.1.5	Comments.....	18
A.2	IUT conformance status	18
A.3	Static conformance summary.....	18
A.4	Dynamic conformance summary.....	18
A.5	Static conformance review report.....	19
A.6	Test campaign report.....	19
A.7	Observations.....	36
	Annex B (normative): Partial PIXIT proforma	37
B.1	Identification summary.....	37
B.2	Abstract test suite summary	37
B.3	Test laboratory.....	37
B.4	Client (of the test laboratory)	38
B.5	System Under Test (SUT)	38
B.6	Protocol information.....	39
B.6.1	Protocol identification	39
B.6.2	Configuration to be tested	39
B.6.3	Configuration options	39
B.6.4	Test management timers	40
B.6.5	Sending of messages by IUT	41
B.6.6	Parameter values.....	41
	Annex C (normative): Abstract Test Suite (ATS)	44
C.1	The TTCN Graphical form (TTCN.GR)	44
C.2	The TTCN Machine Processable form (TTCN.MP)	44
	Annex D (informative): General structure of ATS	45
	History	46

Foreword

This European Telecommunication Standard (ETS) has been produced by the Signalling Protocols and Switching (SPS) Technical Committee of the European Telecommunications Standards Institute (ETSI).

This ETS is part 7 of a multi-part standard covering the Digital Subscriber Signalling System No. one (DSS1) protocol specification for the Integrated Services Digital Network (ISDN) signalling network layer for circuit-mode basic call control, as described below:

- Part 1: "Protocol specification [ITU-T Recommendation Q.931 (1993), modified]";
- Part 2: "Specification and Description Language (SDL) diagrams";
- Part 3: "Protocol Implementation Conformance Statement (PICS) proforma specification";
- Part 4: "Test Suite Structure and Test Purposes (TSS&TP) specification for the user";
- Part 5: "Abstract Test Suite (ATS) and partial Protocol Implementation eXtra Information for Testing (PIXIT) proforma specification for the user";
- Part 6: "TSS&TP specification for the network";
- Part 7: "ATS and partial PIXIT proforma specification for the network".**

Transposition dates	
Date of adoption of this ETS:	20 March 1998
Date of latest announcement of this ETS (doa):	31 July 1998
Date of latest publication of new National Standard or endorsement of this ETS (dop/e):	31 January 1999
Date of withdrawal of any conflicting National Standard (dow):	31 January 1999

Blank page

1 Scope

This seventh part of ETS 300 403 specifies the Abstract Test Suite (ATS) and partial Protocol Implementation eXtra Information for Testing (PIXIT) proforma for the Network side of the T reference point or coincident S and T reference point (as defined in ITU-T Recommendation I.411 [10]) of implementations conforming to the standards for the signalling network layer for circuit-mode basic call control of the Digital Subscriber Signalling System No. one (DSS1) protocol for the pan-European Integrated Services Digital Network (ISDN), ETS 300 403-1 [1] and ETS 300 403-2 [2].

ETS 300 403-6 [4] specifies the Test Suite Structure and Test Purposes (TSS&TP) related to this ATS and partial PIXIT proforma specification. Other parts specify the TSS&TP and the ATS and partial PIXIT proforma for the User side of the T reference point or coincident S and T reference point of implementations conforming to ETS 300 403-1 [1] and ETS 300 403-2 [2].

2 Normative references

This ETS incorporates by dated and undated reference, provisions from other publications. These normative references are cited at the appropriate places in the text and the publications are listed hereafter. For dated references, subsequent amendments to or revisions of any of these publications apply to this ETS only when incorporated in it by amendment or revision. For undated references the latest edition of the publication referred to applies.

- [1] ETS 300 403-1 (1995): "Integrated Services Digital Network (ISDN); Digital Subscriber Signalling System No. one (DSS1) protocol; Signalling network layer for circuit-mode basic call control; Part 1: Protocol specification [ITU-T Recommendation Q.931 (1993), modified]".
- [2] ETS 300 403-2 (1995): "Integrated Services Digital Network (ISDN); Digital Subscriber Signalling System No. one (DSS1) protocol; Signalling network layer for circuit-mode basic call control; Part 2: Specification and Description Language (SDL) diagrams".
- [3] ETS 300 403-3 (1996): "Integrated Services Digital Network (ISDN); Digital Subscriber Signalling System No. one (DSS1) protocol; Signalling network layer for circuit-mode basic call control; Part 3: Protocol Implementation Conformance Statement (PICS) proforma specification".
- [4] ETS 300 403-6: "Integrated Services Digital Network (ISDN); Digital Subscriber Signalling System No. one (DSS1) protocol; Signalling network layer for circuit-mode basic call control; Part 6: Test Suite Structure and Test Purposes (TSS&TP) specification for the network".
- [5] ISO/IEC 9646-1: "Information technology - OSI Conformance Testing Methodology and Framework; Part 1: General Concepts".
- [6] ISO/IEC 9646-2: "Information technology - OSI Conformance Testing Methodology and Framework; Part 2: Abstract Test Suite Specification".
- [7] ISO/IEC 9646-3: "Information technology - OSI Conformance Testing Methodology and Framework; Part 3: The Tree and Tabular Combined Notation".

- [8] ISO/IEC 9646-4: "Information technology - OSI Conformance Testing Methodology and Framework; Part 4: Test realization".
- [9] ISO/IEC 9646-5: "Information technology - OSI Conformance Testing Methodology and Framework; Part 5: Requirements on test laboratories and clients for the conformance assessment process".
- [10] ITU-T Recommendation I.411 (1993): "ISDN user-network interfaces - Reference configurations".

3 Definitions and abbreviations

3.1 Definitions

For the purposes of this ETS, the following definitions apply:

Abstract Test Suite (ATS): See ISO/IEC 9646-1 [5].

Implementation Under Test (IUT): See ISO/IEC 9646-1 [5].

Lower Tester (LT): See ISO/IEC 9646-1 [5].

Point of Control and Observation (PCO): See ISO/IEC 9646-1 [5].

Protocol Implementation Conformance Statement (PICS): See ISO/IEC 9646-1 [5].

PICS proforma: See ISO/IEC 9646-1 [5].

Protocol Implementation eXtra Information for Testing (PIXIT): See ISO/IEC 9646-1 [5].

PIXIT proforma: See ISO/IEC 9646-1 [5].

System Under Test (SUT): See ISO/IEC 9646-1 [5].

Upper Tester (UT): See ISO/IEC 9646-1 [5].

3.2 Abbreviations

For the purposes of this ETS, the following abbreviations apply:

ASP	Abstract Service Primitive
ATM	Abstract Test Method
ATS	Abstract Test Suite
BA	Basic Access
CES	Connection Endpoint Suffix
CM	Co-ordination Message
CP	Co-ordination Point
ExTS	Executable Test Suite
IUT	Implementation Under Test
LT	Lower Tester
MOT	Means Of Testing
MTC	Main Test Component
PCO	Point of Control and Observation
PCTR	Protocol Conformance Test Report
PDU	Protocol Data Unit
PICS	Protocol Implementation Conformance Statement
PIXIT	Protocol Implementation eXtra Information for Testing
PRA	Primary Rate Access
PTC	Parallel Test Component

SUT	System Under Test
TCP	Test Co-ordination Procedures
TP	Test Purpose
TTCN	Tree and Tabular Combined Notation
UT	Upper Tester

4 Abstract Test Method (ATM)

4.1 Description of ATM used

The requirement for testing the network IUT is to focus on the behaviour of the network IUT at the user-network interface where a T reference point or coincident S and T reference point applies. Thus the IUT is the network DSS1 protocol entity at a particular user-network interface and is not the whole network.

It is possible to specify an ATS based on a Single party (remote) test method for such an IUT. However, it is considered that an ATS based on such an approach is of limited use as the only way to specify IUT generated PDUs is to use the "implicit send" statement. Many users of such an ATS would replace the "implicit send" statements with descriptions of the behaviour at other interfaces.

An ATS based on a multi-party test method is considered to be more useful in that it is closer to how a real test suite would be constructed. Such a test method specifies behaviour at multiple network interfaces. One very important limitation here is that tests are focused on one particular interface. Thus the test system is made up one Main Test Component (MTC) and one or more Parallel Test Components (PTC), see figure 1.

4.2 Conventions for test components and PCOs

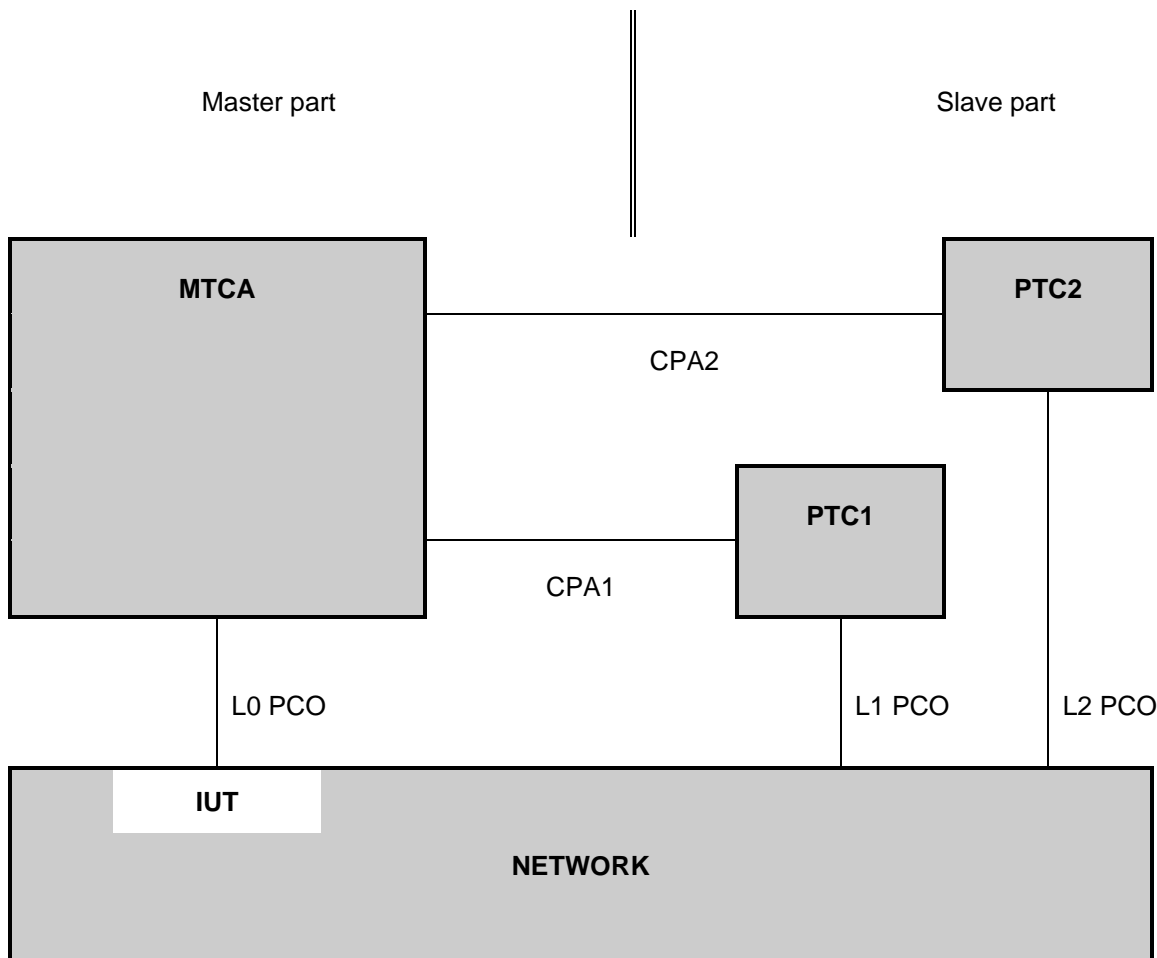

Figure 1: Multi-party test method

In a master/slave arrangement, the MTC is considered to be the master while the PTCs are the slaves. The "slave" testers are only an explicit description of how to deal with the "other" interfaces during the testing process, i.e. "how to make the IUT send the required message".

This means, in particular, that the verdict will only be assigned from the protocol aspects observed on *the* interface under test (i.e. by the "master" tester), as it would be observed by a terminal connected to this interface. A failure in the correlation between the protocol at the different interfaces to which the different testers are connected, i.e. in the mechanism of the functional service itself, will not cause a FAIL verdict. For instance, if the IUT fails to send a message on the tested interface after another interface has received the proper stimulus, the verdict will be INCONCLUSIVE.

The MTC MTCA has two functions in this configuration. Firstly, it has the MTC function of controlling the one or more PTCs. Thus it is responsible for starting the PTCs and afterwards co-ordinates activities by exchanging Co-ordination Messages (CM) with the PTCs. Secondly it is responsible for the behaviour of the Lower Tester (LT) at PCO L0.

A combination of the remote and multi-party test methods is applied. As can be seen from figure 1, several PCOs are used. All PCOs reside at the service access points between layers 2 and 3.

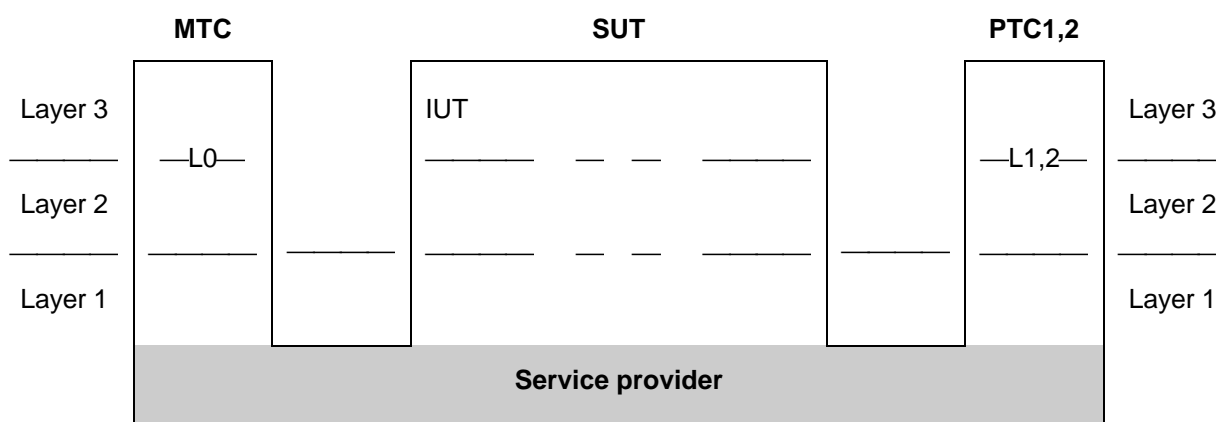

Figure 2: Combination of the remote and multi-party test methods

The MTC PCO is named "L0" ("L" for Lower). The L0 PCO is used to control and observe the behaviour of the IUT and test case verdicts are assigned depending on the behaviour observed at this PCO. The PTCs PTC1, PTC2 etc. use PCOs L1, L2 etc. These PCOs are used to control and, in a limited way, observe the behaviour of the network equipment at interfaces other than the one under test. No verdicts are assigned at these PCOs.

As stated in a previous paragraph, the non-receipt of network generated messages at L0, which are stimulated by events at the L1, L2 etc., will result in INCONCLUSIVE rather than FAIL verdicts being assigned.

PTC2 is only activated in a small set of test cases that test the handling of two calls at one time. In test cases which verify that the IUT rejects invalid or unacceptable SETUP messages, no PTC is activated at all, as these rejection procedures are considered local to the access between IUT and MTC.

The capability of the IUT to send INFORMATION and PROGRESS messages is tested in different call states. Implicit send events have to be used in this small set of test cases, as the sending of those messages cannot be triggered via a PTC. Separate PIXIT questions are asked for each call state, if and how it is possible for the test operator to cause the sending of the messages.

4.3 Conventions for point-to-multipoint configurations

For this group, PTC3 is connected to the same basic access as the MTC. Thus messages that are sent to the MTC via the broadcast data link will be received at PTC3 via PCO L3 as well. Both the MTC and PTC3 will send messages on the same access using the same call reference value. A distinction between the two message flows related to the PCOs L0 and L3 can still be made, as they use different data link entities. This approach, representing a slight modification in the test method, is illustrated in figure 3. This shows that the part of the network considered to be the IUT is connected to both the MTC and PTC3. PTC2 is not used in that configuration.

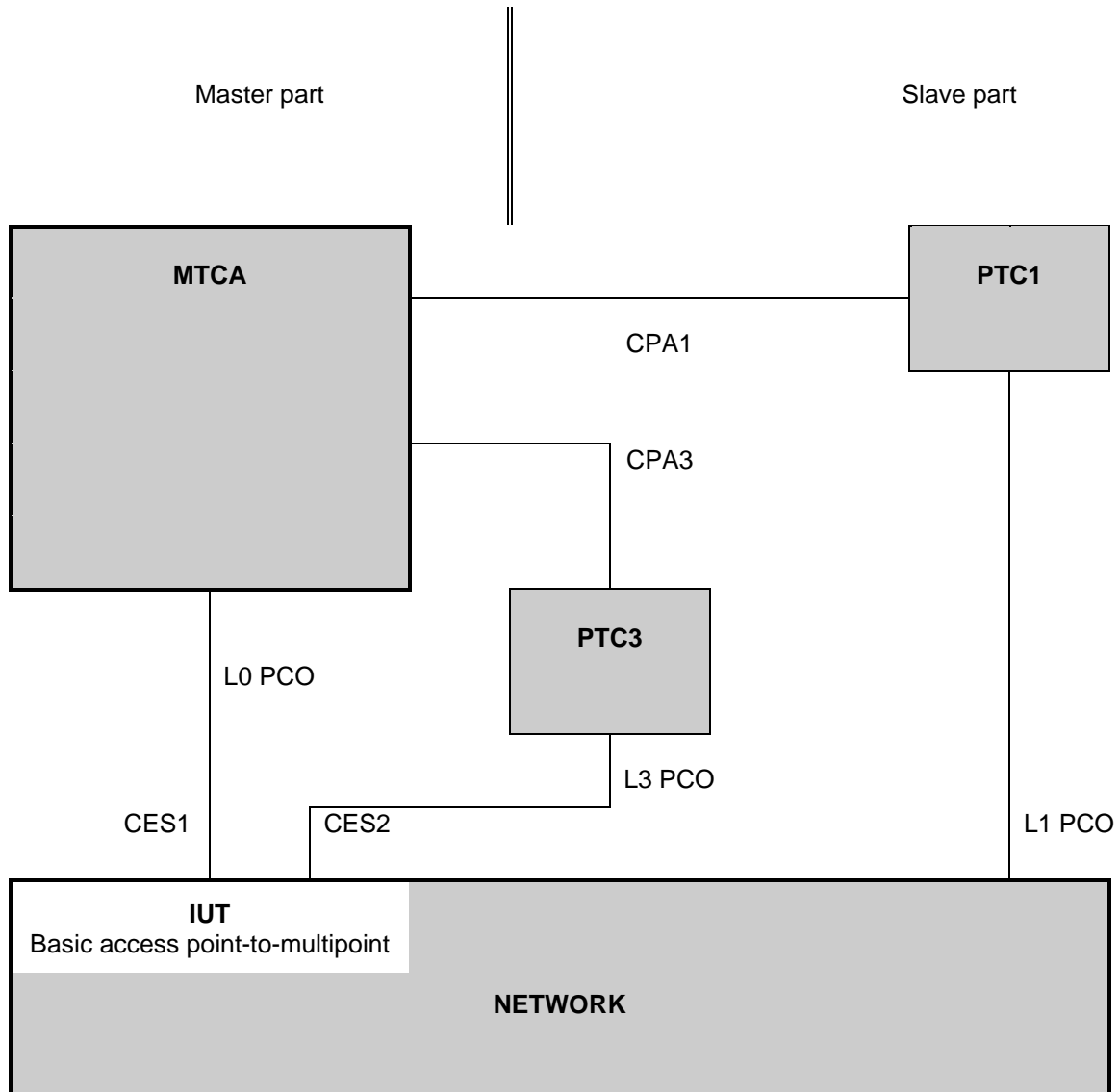

Figure 3: Multi-party test method - modified for point-to-multipoint configurations

5 Untestable test purposes

There are no untestable test purposes associated with this ATS and ATM.

6 ATS conventions

This clause is structured similarly to the structure of a TTCN ATS. However, the names of the subclauses are arranged in a way more suitable to this ETS.

6.1 Declarations part

6.1.1 Type definitions

6.1.1.1 Simple type definitions

Where appropriate, simple types have a length, a value list or a range restriction attached.

Simple types defined as being of some string type (e.g. BIT STRING, OCTET STRING), have a length restriction or a value list attached.

Simple types, defined as being of INTEGER type, have a value list or a range restriction attached.

6.1.1.2 Structured type definitions

6.1.1.2.1 TTCN structured type definitions

All structured type definitions are provided with a full name.

All elements in every structured type definition, defined as being of some string type (e.g. BIT STRING, OCTET STRING), have a length restriction attached.

If an element in a structured type definition is defined as being of a referenced type, the (possible) restriction is defined in that referenced type.

For information elements the identifier, which is unique for each element, has its type defined as a simple type where the value list is restricted to the single value which is the identifier itself. This has the advantage that it allows a test system derived from this ATS to easily identify information elements embedded in messages. An ATS where information element identifiers are represented as unrestricted types can present difficulties for a derived test system in the case where it needs to find one information element embedded in a number of others and the constraints for the other elements have the any-or-omit value. In such a case the test system cannot easily find the beginning of each information element.

6.1.1.2.2 ASN.1 structured type definitions

There are no ASN.1 structured type definitions in the ATS.

6.1.1.3 ASP type definitions

6.1.1.3.1 TTCN ASP type definitions

TTCN ASP type definitions only contain one PDU or no PDU at all.

All TTCN ASP type definitions are provided with a full identifier.

Some ASPs are not parameterized as shown in the example in table 1. Such ASPs are only used for requesting or receiving service from the lower layer.

Table 1: TTCN ASP type definition DL_REL_IN

TTCN ASP Type Definition		
ASP NAME : DL_REL_IN (DL_RELEASE_INDICATION)		
PCO Type : SAP		
Comments :		
Parameter Name	Parameter Type	Comments
Detailed Comments :		

Table 2 shows an example of a parameterized ASP. All ASPs containing PDUs contain only that PDU and no other parameters.

Table 2: TTCN ASP type definition DL_DATA_RQ

TTCN ASP Type Definition		
ASP NAME : DL_DATA_RQ (DL_DATA_REQUEST)		
PCO Type : SAP		
Comments :		
Parameter Name	Parameter Type	Comments
mun (MessageUnit)	PDU	
Detailed Comments :		

6.1.1.3.2 ASN.1 ASP type definitions

There are no ASN.1 ASP type definitions in the ATS.

6.1.1.4 PDU type definitions

6.1.1.4.1 TTCN PDU type definitions

The TTCN PDU type reflects the actual data being transferred or received. All PDUs are embedded in ASPs.

If a specific PDU type definition contains elements defined in terms of a pre-defined type, that element has a restriction attached to it.

6.1.1.4.2 ASN.1 PDU type definitions

There are no ASN.1 PDU type definitions in the ATS.

6.1.2 Test suite constants

Each test suite constant is defined in terms of a predefined type or a referenced type. The values given in the value column will remain unchanged throughout the test suite.

6.1.3 Test suite parameters

Each test suite parameter is defined in terms of a predefined type or a referenced type. A referenced type is used when it is necessary to attach restrictions to these type definitions (it is not allowed to include restrictions directly in the test suite parameter table). The referenced type can have a length or value restriction attached to it in its declaration table.

6.1.4 Variables

6.1.4.1 Test suite variables

No test suite variables are used or defined in this ATS.

6.1.4.2 Test case variables

Each test case variable is defined in terms of a predefined type or a referenced type. A referenced type is used when it is necessary to attach restrictions to these type definitions (it is not allowed to include restrictions directly in the test case variable table). The referenced type can have a length or value restriction attached to it in its declaration table.

Where test case variables are used in constraints, they are passed as formal parameters.

6.1.5 Test suite operation definitions

The description part of a test suite operation definition uses either natural language or meta C.

Table 3: Test suite operation definition ASSIGN_CHI

Test Suite Operation Definition	
Operation Name	: ASSIGN_CHI(basic, primary : CHI; basic_flag : BOOLEAN)
Result Type	: CHI
Comments	: This operation is used to assign a correct Channel identification information element to PDUs dependent on the type of access that is tested.
Description	
CHI ASSIGN_CHI(basic,primary,basic_flag)	
If the value of the basic_flag is set to TRUE, the result of the operation ASSIGN_CHI will be the value represented by the parameter basic which is of type CHI. Else the operation results in the value represented by the parameter primary.	
Examples: ASSIGN_CHI(CHI1b_R1, CHI1p_R1, TRUE) = CHI1b_R1 ASSIGN_CHI(CHI1b_R1, CHI1p_R1, FALSE) = CHI1p_R1	
Detailed comments :	

The test suite operation definition shown in table 3 is used in the constraints part when assigning an element of type CHI a value. The CHI type can be defined in two ways depending on whether the ATS is testing basic or primary rate access. To avoid duplicate types and thereby duplicate test cases this operation is used to assign a value to an element of CHI type. It takes three parameters:

```
primary:      a constraint of type CHI valid for Primary-rate access;
basic:        a constraint of type CHI valid for Basic access;
basic_flag:   a Boolean value: TRUE if basic access is applicable, FALSE otherwise.
```

This operation returns the correct constraint according to the Boolean flag basic_flag. That constraint will then be assigned to the specific element of type CHI.

6.2 Constraints part

6.2.1 Structured type constraint declaration

For every structured type definition there exists one or more structured type constraint.

6.2.2 ASN.1 type constraint declaration

There are no ASN.1 type constraint declarations in the ATS.

6.2.3 ASP type constraint declaration

6.2.3.1 ASN.1 ASP type constraint declaration

There are no ASN.1 ASP type constraint declarations in the ATS.

6.2.3.2 TTCN ASP type constraint declaration

The PDUs to be sent or received are passed to the TTCN ASP constraint declarations Ms and Mr as parameters of meta type PDU. Only if values inside a specific PDU have to be referenced, the use of the meta type PDU is not allowed according to ISO/IEC 9646-3 [7]. In such cases different TTCN ASP constraint declarations are used, that are defined to carry only a specific type of PDU (e.g. SETUP).

Table 4 shows an example of such a TTCN ASP constraint declaration.

Table 4: TTCN ASP constraint declaration Sr

TTCN ASP Constraint Declaration		
Constraint Name	: Sr(PARAM: SETUP_PDU)	
ASP Type	: DL_DAT_IN_SETUP	
Derivation Path	:	
Comments	: ASP to indicate the receipt of SETUP messages.	
Parameter Name	Parameter Value	Comments
mun	PARAM	
Detailed Comments :		

All ASP constraints have a specific value for its parameter. No matching symbols are used in ASPs.

6.2.4 PDU type constraint declaration

6.2.4.1 ASN.1 PDU type constraint declaration

There are no ASN.1 PDU type constraint declarations in the ATS.

6.2.4.2 TTCN PDU type constraint declaration

PDU constraints are used for assigning values or patterns to the data being sent or received.

6.2.5 Derived constraints

Derived constraints are used in this ATS only for SETUP and ERROR PDUs.

6.2.6 Parameterized constraints

Parameterized constraints are used in this ATS.

6.2.7 Value assignment

6.2.7.1 Specific values

For specific value assignment both explicit values and references to explicit values are used.

6.2.7.2 Matching values

As matching values the following mechanisms are used:

Instead of Value:

AnyOrOmit	"**"
AnyValue	"?"
Omit	"_"

Inside value:

AnyOne	"?"
AnyOrNone	"**"

6.3 Dynamic part

6.3.1 Test cases

Each test case contains the test purpose text from ETS 300 403-6 [4]. To be able to read and understand the test case dynamic behaviour it is recommended that the test steps are understood first.

6.3.2 Test steps

Much use has been made of test steps to avoid needless repetition of dynamic behaviour.

6.3.3 Defaults

Note the use of the RETURN statement which is defined in DAM1 of ISO/IEC 9646-3 [7]. This allows valid background behaviour to be handled in the default tree with a possibility to return to the original set of alternatives in the test case.

7 ATS to TP map

The identifiers used for the TPs are reused as test case names. Thus there is a straightforward one-to-one mapping.

8 PCTR conformance

A test laboratory, when requested by a client to produce a PCTR, is required, as specified in ISO/IEC 9646-5 [9], to produce a PCTR conformant with the PCTR template given in annex B of ISO/IEC 9646-5 [9].

Furthermore, a test laboratory, offering testing for the ATS specification contained in annex C, when requested by a client to produce a PCTR, is required to produce a PCTR conformant with the PCTR proforma contained in annex A of this ETS.

A PCTR which conforms to this PCTR proforma specification shall preserve the content and ordering of the clauses contained in annex A. Clause A.6 of the PCTR may contain additional columns. If included, these shall be placed to the right of the existing columns. Text in italics may be retained by the test laboratory.

9 PIXIT conformance

A test realizer, producing an Executable Test Suite (ExTS) for the ATS specification contained in annex C, is required, as specified in ISO/IEC 9646-4 [8], to produce an augmented partial PIXIT proforma conformant with this partial PIXIT proforma specification.

An augmented partial PIXIT proforma which conforms to this partial PIXIT proforma specification shall, as a minimum, have contents which are technically equivalent to annex B. The augmented partial PIXIT proforma may contain additional questions that need to be answered in order to prepare the Means Of Testing (MOT) for a particular IUT.

A test laboratory, offering testing for the ATS specification contained in annex C, is required, as specified in ISO/IEC 9646-5 [9], to further augment the augmented partial PIXIT proforma to produce a PIXIT proforma conformant with this partial PIXIT proforma specification.

A PIXIT proforma which conforms to this partial PIXIT proforma specification shall, as a minimum, have contents which are technically equivalent to annex B. The PIXIT proforma may contain additional questions that need to be answered in order to prepare the test laboratory for a particular IUT.

10 ATS conformance

The test realizer, producing MOT and ExTS for this ATS specification, shall comply with the requirements of ISO/IEC 9646-4 [8]. In particular, these concern the realization of an ExTS based on each ATS. The test realizer shall provide a statement of conformance of the MOT to this ATS specification.

An ExTS which conforms to this ATS specification shall contain test groups and test cases which are technically equivalent to those contained in the ATS in annex C. All sequences of test events comprising an abstract test case shall be capable of being realized in the executable test case. Any further checking which the test system might be capable of performing is outside the scope of this ATS specification and shall not contribute to the verdict assignment for each test case.

Test laboratories running conformance test services using this ATS shall comply with ISO/IEC 9646-5 [9].

A test laboratory which claims to conform to this ATS specification shall use an MOT which conforms to this ATS.

Annex A (normative): Protocol Conformance Test Report (PCTR) proforma

Notwithstanding the provisions of the copyright clause related to the text of this ETS, ETSI grants that users of this ETS may freely reproduce the PCTR proforma in this annex so that it can be used for its intended purposes and may further publish the completed PCTR.

A.1 Identification summary

A.1.1 Protocol conformance test report

PCTR number:	
PCTR date:	
Corresponding SCTR number:	
Corresponding SCTR date:	
Test laboratory identification:	
Test laboratory manager:	
Signature:	

A.1.2 IUT identification

Name:	
Version:	
Protocol specification:	ETS 300 403-1
PICS:	
Previous PCTRs (if any):	

A.1.3 Testing environment

PIXIT reference number:	
ATS specification:	ETS 300 403-7
Abstract test method:	Multi-party test method (see ISO/IEC 9646-2)
Means of testing identification:	
Dates of testing:	
Conformance log reference(s):	
Retention date for log reference(s):	

A.1.4 Limits and reservations

Additional information relevant to the technical contents or further use of the test report, or to the rights and obligations of the test laboratory and the client, may be given here. Such information may include restriction on the publication of the report.

.....
.....
.....
.....

A.1.5 Comments

Additional comments may be given by either the client or the test laboratory on any of the contents of the PCTR, for example, to note disagreement between the two parties.

.....
.....
.....
.....

A.2 IUT conformance status

This IUT has / has not been shown by conformance assessment to be non-conforming to the specified protocol specification.

Strike the appropriate words in this sentence. If the PICS for this IUT is consistent with the static conformance requirements (as specified in clause A.3 of this report) and there are no "FAIL" verdicts to be recorded (in clause A.6) strike the word "has", otherwise strike the words "has not".

A.3 Static conformance summary

The PICS for this IUT is / is not consistent with the static conformance requirements in the specified protocol.

Strike the appropriate words in this sentence.

A.4 Dynamic conformance summary

The test campaign did / did not reveal errors in the IUT.

Strike the appropriate words in this sentence. If there are no "FAIL" verdicts to be recorded (in clause A.6 of this report) strike the word "did", otherwise strike the words "did not".

Summary of the results of groups of tests:

.....
.....
.....
.....
.....

A.5 Static conformance review report

If clause A.3 indicates non-conformance, this clause itemizes the mismatches between the PICS and the static conformance requirements of the specified protocol specification.

.....

.....

.....

.....

.....

.....

.....

.....

A.6 Test campaign report

Call state N00				
ATS reference	Selected? (Y/N)	Run? (Y/N)	Verdict	Observations
L3N_N00_V_001				
L3N_N00_V_002				
L3N_N00_V_003				
L3N_N00_V_004				
L3N_N00_V_005				
L3N_N00_V_006				
L3N_N00_V_007				
L3N_N00_V_008				
L3N_N00_V_009				
L3N_N00_V_010				
L3N_N00_V_011				
L3N_N00_V_012				
L3N_N00_V_013				
L3N_N00_V_014				
L3N_N00_V_015				
L3N_N00_V_016				
L3N_N00_V_017				
L3N_N00_V_018				
L3N_N00_V_019				
L3N_N00_V_020				
L3N_N00_V_021				
L3N_N00_V_022				
L3N_N00_V_023				
L3N_N00_V_024				
L3N_N00_V_025				
L3N_N00_V_026				
L3N_N00_V_027				
L3N_N00_V_028				
L3N_N00_V_029				
(continued)				

Call state N00 (concluded)				
ATS reference	Selected? (Y/N)	Run? (Y/N)	Verdict	Observations
L3N_N00_V_030				
L3N_N00_V_031				
L3N_N00_V_032				
L3N_N00_V_033				
L3N_N00_V_034				
L3N_N00_V_035				
L3N_N00_V_036				
L3N_N00_V_037				
L3N_N00_V_038				
L3N_N00_V_039				
L3N_N00_V_040				
L3N_N00_V_041				
L3N_N00_V_042				
L3N_N00_V_043				
L3N_N00_V_044				
L3N_N00_V_045				
L3N_N00_V_046				
L3N_N00_V_047				
L3N_N00_V_048				
L3N_N00_V_049				
L3N_N00_V_050				
L3N_N00_V_051				
L3N_N00_V_052				
L3N_N00_V_053				
L3N_N00_V_054				
L3N_N00_V_055				
L3N_N00_V_056				
L3N_N00_V_057				
L3N_N00_I_001				
L3N_N00_I_002				
L3N_N00_I_003				
L3N_N00_I_004				
L3N_N00_I_005				
L3N_N00_I_006				
L3N_N00_I_007				
L3N_N00_I_008				
L3N_N00_I_009				
L3N_N00_I_010				
L3N_N00_I_011				
L3N_N00_I_012				
L3N_N00_I_013				
L3N_N00_S_001				
L3N_N00_S_002				
L3N_N00_S_003				
L3N_N00_S_004				
L3N_N00_S_005				
L3N_N00_S_006				
L3N_N00_S_007				
L3N_N00_S_008				
L3N_N00_S_009				
L3N_N00_S_010				
L3N_N00_S_011				
L3N_N00_S_012				

Call state N02				
ATS reference	Selected? (Y/N)	Run? (Y/N)	Verdict	Observations
L3N_N02_V_001				
L3N_N02_V_002				
L3N_N02_V_003				
L3N_N02_V_004				
L3N_N02_V_005				
L3N_N02_V_006				
L3N_N02_V_007				
L3N_N02_V_008				
L3N_N02_V_009				
L3N_N02_V_010				
L3N_N02_V_011				
L3N_N02_V_012				
L3N_N02_V_013				
L3N_N02_I_001				
L3N_N02_I_002				
L3N_N02_I_003				
L3N_N02_I_004				
L3N_N02_I_005				
L3N_N02_I_006				
L3N_N02_I_007				
L3N_N02_I_008				
L3N_N02_I_009				
L3N_N02_I_010				
L3N_N02_I_011				
L3N_N02_S_001				
L3N_N02_S_002				
L3N_N02_S_003				
L3N_N02_S_004				
L3N_N02_S_005				
L3N_N02_S_006				
L3N_N02_S_007				
L3N_N02_S_008				
L3N_N02_S_009				
L3N_N02_S_010				

Call state N03				
ATS reference	Selected? (Y/N)	Run? (Y/N)	Verdict	Observations
L3N_N03_V_001				
L3N_N03_V_002				
L3N_N03_V_003				
L3N_N03_V_004				
L3N_N03_V_005				
L3N_N03_V_006				
L3N_N03_V_007				
L3N_N03_V_008				
L3N_N03_V_009				
L3N_N03_V_010				
L3N_N03_V_011				
L3N_N03_V_012				
L3N_N03_I_001				
L3N_N03_I_002				
L3N_N03_I_003				
L3N_N03_I_004				
L3N_N03_I_005				
L3N_N03_I_006				
L3N_N03_I_007				
L3N_N03_I_008				
L3N_N03_I_009				
L3N_N03_I_010				
L3N_N03_S_001				
L3N_N03_S_002				
L3N_N03_S_003				
L3N_N03_S_004				
L3N_N03_S_005				
L3N_N03_S_006				
L3N_N03_S_007				
L3N_N03_S_008				
L3N_N03_S_009				
L3N_N03_S_010				

Call state N04				
ATS reference	Selected? (Y/N)	Run? (Y/N)	Verdict	Observations
L3N_N04_V_001				
L3N_N04_V_002				
L3N_N04_V_003				
L3N_N04_V_004				
L3N_N04_V_005				
L3N_N04_V_006				
L3N_N04_V_007				
L3N_N04_V_008				
L3N_N04_V_009				
L3N_N04_I_001				
L3N_N04_I_002				
L3N_N04_I_003				
L3N_N04_I_004				
L3N_N04_I_005				
L3N_N04_I_006				
L3N_N04_I_007				
L3N_N04_I_008				
L3N_N04_I_009				
L3N_N04_I_010				
L3N_N04_S_001				
L3N_N04_S_002				
L3N_N04_S_003				
L3N_N04_S_004				
L3N_N04_S_005				
L3N_N04_S_006				
L3N_N04_S_007				
L3N_N04_S_008				
L3N_N04_S_009				
L3N_N04_S_010				

Call state N06				
ATS reference	Selected? (Y/N)	Run? (Y/N)	Verdict	Observations
L3N_N06_V_001				
L3N_N06_V_002				
L3N_N06_V_003				
L3N_N06_V_004				
L3N_N06_V_005				
L3N_N06_V_006				
L3N_N06_V_007				
L3N_N06_V_008				
L3N_N06_V_009				
L3N_N06_V_010				
L3N_N06_V_011				
L3N_N06_V_012				
L3N_N06_V_013				
L3N_N06_V_014				
L3N_N06_V_015				
L3N_N06_V_016				
L3N_N06_V_017				
L3N_N06_V_018				
L3N_N06_V_019				
L3N_N06_V_020				
L3N_N06_V_021				
L3N_N06_V_022				
L3N_N06_V_023				
L3N_N06_V_024				
L3N_N06_V_025				
L3N_N06_V_026				
L3N_N06_V_027				
L3N_N06_V_028				
L3N_N06_V_029				
L3N_N06_V_030				
L3N_N06_V_031				
L3N_N06_V_032				
L3N_N06_V_033				
L3N_N06_V_034				
L3N_N06_V_035				
L3N_N06_V_036				
L3N_N06_V_037				
L3N_N06_V_038				
L3N_N06_V_039				
L3N_N06_V_040				
L3N_N06_V_041				
L3N_N06_V_042				
L3N_N06_V_043				
L3N_N06_V_044				
L3N_N06_V_045				
L3N_N06_V_046				
L3N_N06_V_047				
(continued)				

Call state N06 (concluded)				
ATS reference	Selected? (Y/N)	Run? (Y/N)	Verdict	Observations
L3N_N06_I_001				
L3N_N06_I_002				
L3N_N06_I_003				
L3N_N06_I_004				
L3N_N06_I_005				
L3N_N06_I_006				
L3N_N06_I_007				
L3N_N06_I_008				
L3N_N06_I_009				
L3N_N06_S_001				
L3N_N06_S_002				
L3N_N06_S_003				
L3N_N06_S_004				
L3N_N06_S_005				
L3N_N06_S_006				
L3N_N06_S_007				
L3N_N06_S_008				
L3N_N06_S_009				

Call state N07				
ATS reference	Selected? (Y/N)	Run? (Y/N)	Verdict	Observations
L3N_N07_V_001				
L3N_N07_V_002				
L3N_N07_V_003				
L3N_N07_V_004				
L3N_N07_V_005				
L3N_N07_V_006				
L3N_N07_V_007				
L3N_N07_V_008				
L3N_N07_V_004				
L3N_N07_V_010				
L3N_N07_V_011				
L3N_N07_V_012				
L3N_N07_V_013				
L3N_N07_V_014				
L3N_N07_V_015				
L3N_N07_V_016				
L3N_N07_V_017				
L3N_N07_V_018				
L3N_N07_V_019				
L3N_N07_V_020				
L3N_N07_V_021				
L3N_N07_V_022				
L3N_N07_I_001				
L3N_N07_I_002				
L3N_N07_I_003				
L3N_N07_I_004				
L3N_N07_I_005				
L3N_N07_I_006				
L3N_N07_I_007				
L3N_N07_I_008				
L3N_N07_I_009				
L3N_N07_I_010				
L3N_N07_I_011				
L3N_N07_I_012				
L3N_N07_I_013				
L3N_N07_I_014				
L3N_N07_I_015				
L3N_N07_I_016				
L3N_N07_I_017				
L3N_N07_I_018				
L3N_N07_I_019				
L3N_N07_S_001				
L3N_N07_S_002				
L3N_N07_S_003				
L3N_N07_S_004				
L3N_N07_S_005				
L3N_N07_S_006				
L3N_N07_S_007				
L3N_N07_S_008				
L3N_N07_S_009				
L3N_N07_S_010				
L3N_N07_S_011				

Call state N09				
ATS reference	Selected? (Y/N)	Run? (Y/N)	Verdict	Observations
L3N_N09_V_001				
L3N_N09_V_002				
L3N_N09_V_003				
L3N_N09_V_004				
L3N_N09_V_005				
L3N_N09_V_006				
L3N_N09_V_007				
L3N_N09_V_008				
L3N_N09_V_009				
L3N_N09_V_010				
L3N_N09_V_011				
L3N_N09_V_012				
L3N_N09_V_013				
L3N_N09_V_014				
L3N_N09_V_015				
L3N_N09_V_016				
L3N_N09_V_017				
L3N_N09_V_018				
L3N_N09_V_019				
L3N_N09_V_020				
L3N_N09_V_021				
L3N_N09_V_022				
L3N_N09_V_023				
L3N_N09_I_001				
L3N_N09_I_002				
L3N_N09_I_003				
L3N_N09_I_004				
L3N_N09_I_005				
L3N_N09_I_006				
L3N_N09_I_007				
L3N_N09_I_008				
L3N_N09_I_009				
L3N_N09_I_010				
L3N_N09_I_011				
L3N_N09_I_012				
L3N_N09_I_013				
L3N_N09_I_014				
L3N_N09_I_015				
L3N_N09_I_016				
L3N_N09_I_017				
L3N_N09_I_018				
L3N_N09_S_001				
L3N_N09_S_002				
L3N_N09_S_003				
L3N_N09_S_004				
L3N_N09_S_005				
L3N_N09_S_006				
L3N_N09_S_007				
L3N_N09_S_008				
L3N_N09_S_009				
L3N_N09_S_010				
L3N_N09_S_011				

Call state N10, incoming call				
ATS reference	Selected? (Y/N)	Run? (Y/N)	Verdict	Observations
L3N_N10I_V_001				
L3N_N10I_V_002				
L3N_N10I_V_003				
L3N_N10I_V_004				
L3N_N10I_V_005				
L3N_N10I_V_006				
L3N_N10I_V_007				
L3N_N10I_V_008				
L3N_N10I_V_009				
L3N_N10I_V_010				
L3N_N10I_V_011				
L3N_N10I_V_012				
L3N_N10I_V_013				
L3N_N10I_V_014				
L3N_N10I_V_015				
L3N_N10I_V_016				
L3N_N10I_V_017				
L3N_N10I_V_018				
L3N_N10I_V_019				
L3N_N10I_V_020				
L3N_N10I_V_021				
L3N_N10I_I_001				
L3N_N10I_I_002				
L3N_N10I_I_003				
L3N_N10I_I_004				
L3N_N10I_I_005				
L3N_N10I_I_006				
L3N_N10I_I_007				
L3N_N10I_I_008				
L3N_N10I_I_009				
L3N_N10I_I_010				
L3N_N10I_I_011				
L3N_N10I_S_001				
L3N_N10I_S_002				
L3N_N10I_S_003				
L3N_N10I_S_004				
L3N_N10I_S_005				
L3N_N10I_S_006				
L3N_N10I_S_007				
L3N_N10I_S_008				
L3N_N10I_S_009				
L3N_N10I_S_010				

Call state N10, outgoing call				
ATS reference	Selected? (Y/N)	Run? (Y/N)	Verdict	Observations
L3N_N100_V_001				
L3N_N100_V_002				
L3N_N100_V_003				
L3N_N100_V_004				
L3N_N100_V_005				
L3N_N100_V_006				
L3N_N100_V_007				
L3N_N100_V_008				
L3N_N100_V_009				
L3N_N100_V_010				
L3N_N100_V_011				
L3N_N100_V_012				
L3N_N100_V_013				
L3N_N100_V_014				
L3N_N100_V_015				
L3N_N100_V_016				
L3N_N100_V_017				
L3N_N100_V_018				
L3N_N100_V_019				
L3N_N100_V_020				
L3N_N100_I_001				
L3N_N100_I_002				
L3N_N100_I_003				
L3N_N100_I_004				
L3N_N100_I_005				
L3N_N100_I_006				
L3N_N100_I_007				
L3N_N100_I_008				
L3N_N100_I_009				
L3N_N100_I_010				
L3N_N100_I_011				
L3N_N100_I_012				
L3N_N100_S_001				
L3N_N100_S_002				
L3N_N100_S_003				
L3N_N100_S_004				
L3N_N100_S_005				
L3N_N100_S_006				
L3N_N100_S_007				
L3N_N100_S_008				
L3N_N100_S_009				
L3N_N100_S_010				

Call state N12, incoming call				
ATS reference	Selected? (Y/N)	Run? (Y/N)	Verdict	Observations
L3N_N12I_V_001				
L3N_N12I_V_002				
L3N_N12I_V_003				
L3N_N12I_V_004				
L3N_N12I_V_005				
L3N_N12I_V_006				
L3N_N12I_V_007				
L3N_N12I_I_001				
L3N_N12I_I_002				
L3N_N12I_I_003				
L3N_N12I_I_004				
L3N_N12I_I_005				
L3N_N12I_I_006				
L3N_N12I_I_007				
L3N_N12I_I_008				
L3N_N12I_S_001				
L3N_N12I_S_002				
L3N_N12I_S_003				
L3N_N12I_S_004				
L3N_N12I_S_005				
L3N_N12I_S_006				
L3N_N12I_S_007				
L3N_N12I_S_008				

Call state N12, outgoing call				
ATS reference	Selected? (Y/N)	Run? (Y/N)	Verdict	Observations
L3N_N12O_V_001				
L3N_N12O_V_002				
L3N_N12O_V_003				
L3N_N12O_V_004				
L3N_N12O_V_005				
L3N_N12O_V_006				
L3N_N12O_V_007				
L3N_N12O_I_001				
L3N_N12O_I_002				
L3N_N12O_I_003				
L3N_N12O_I_004				
L3N_N12O_I_005				
L3N_N12O_I_006				
L3N_N12O_I_007				
L3N_N12O_I_008				
L3N_N12O_I_009				
L3N_N12O_S_001				
L3N_N12O_S_002				
L3N_N12O_S_003				
L3N_N12O_S_004				
L3N_N12O_S_005				
L3N_N12O_S_006				
L3N_N12O_S_007				
L3N_N12O_S_008				

Call state N19, incoming call				
ATS reference	Selected? (Y/N)	Run? (Y/N)	Verdict	Observations
L3N_N19I_V_001				
L3N_N19I_V_002				
L3N_N19I_V_003				
L3N_N19I_V_004				
L3N_N19I_V_005				
L3N_N19I_V_006				
L3N_N19I_V_007				
L3N_N19I_I_001				
L3N_N19I_I_002				
L3N_N19I_I_003				
L3N_N19I_I_004				
L3N_N19I_I_005				
L3N_N19I_I_006				
L3N_N19I_I_007				
L3N_N19I_I_008				
L3N_N19I_S_001				
L3N_N19I_S_002				
L3N_N19I_S_003				
L3N_N19I_S_004				
L3N_N19I_S_005				
L3N_N19I_S_006				
L3N_N19I_S_007				
L3N_N19I_S_008				

Call state U19, outgoing call				
ATS reference	Selected? (Y/N)	Run? (Y/N)	Verdict	Observations
L3N_N19O_V_001				
L3N_N19O_V_002				
L3N_N19O_V_003				
L3N_N19O_V_004				
L3N_N19O_V_005				
L3N_N19O_V_006				
L3N_N19O_V_007				
L3N_N19O_I_001				
L3N_N19O_I_002				
L3N_N19O_I_003				
L3N_N19O_I_004				
L3N_N19O_I_005				
L3N_N19O_I_006				
L3N_N19O_I_007				
L3N_N19O_I_008				
L3N_N19O_I_009				
L3N_N19O_S_001				
L3N_N19O_S_002				
L3N_N19O_S_003				
L3N_N19O_S_004				
L3N_N19O_S_005				
L3N_N19O_S_006				
L3N_N19O_S_007				
L3N_N19O_S_008				

Call state N22				
ATS reference	Selected? (Y/N)	Run? (Y/N)	Verdict	Observations
L3N_N22_V_001				
L3N_N22_V_002				
L3N_N22_V_003				
L3N_N22_V_004				
L3N_N22_V_005				
L3N_N22_V_006				
L3N_N22_V_007				
L3N_N22_V_008				
L3N_N22_V_009				
L3N_N22_V_010				
L3N_N22_V_011				
L3N_N22_V_012				
L3N_N22_V_013				
L3N_N22_V_014				

Call state N25				
ATS reference	Selected? (Y/N)	Run? (Y/N)	Verdict	Observations
L3N_N25_V_001				
L3N_N25_V_002				
L3N_N25_V_003				
L3N_N25_V_004				
L3N_N25_V_005				
L3N_N25_V_006				
L3N_N25_V_007				
L3N_N25_V_008				
L3N_N25_V_009				
L3N_N25_V_010				
L3N_N25_V_011				
L3N_N25_V_012				
L3N_N25_V_013				
L3N_N25_V_014				
L3N_N25_V_015				
L3N_N25_V_016				
L3N_N25_V_017				
L3N_N25_V_018				
L3N_N25_V_019				
L3N_N25_V_020				
L3N_N25_V_021				
L3N_N25_V_022				
L3N_N25_V_023				
L3N_N25_V_024				
L3N_N25_V_025				
L3N_N25_V_026				
L3N_N25_V_027				
L3N_N25_V_028				
(continued)				

Call state N25 (concluded)				
ATS reference	Selected? (Y/N)	Run? (Y/N)	Verdict	Observations
L3N_N25_I_001				
L3N_N25_I_002				
L3N_N25_I_003				
L3N_N25_I_004				
L3N_N25_I_005				
L3N_N25_I_006				
L3N_N25_I_007				
L3N_N25_I_008				
L3N_N25_I_009				
L3N_N25_I_010				
L3N_N25_I_011				
L3N_N25_I_012				
L3N_N25_I_013				
L3N_N25_I_014				
L3N_N25_I_015				
L3N_N25_I_016				
L3N_N25_I_017				
L3N_N25_I_018				
L3N_N25_S_001				
L3N_N25_S_002				
L3N_N25_S_003				
L3N_N25_S_004				
L3N_N25_S_005				
L3N_N25_S_006				
L3N_N25_S_007				
L3N_N25_S_008				
L3N_N25_S_009				
L3N_N25_S_010				
L3N_N25_S_011				

Call state R00, incoming call				
ATS reference	Selected? (Y/N)	Run? (Y/N)	Verdict	Observations
L3N_R00I_V_001				
L3N_R00I_V_002				
L3N_R00I_V_003				
L3N_R00I_V_004				
L3N_R00I_V_005				
L3N_R00I_V_006				
L3N_R00I_V_007				
L3N_R00I_V_008				
L3N_R00I_I_001				
L3N_R00I_I_002				
L3N_R00I_I_003				
L3N_R00I_S_001				
L3N_R00I_S_002				
L3N_R00I_S_003				
L3N_R00I_S_004				
L3N_R00I_S_005				
L3N_R00I_S_006				
L3N_R00I_S_007				
L3N_R00I_S_008				
L3N_R00I_S_009				
L3N_R00I_S_010				
L3N_R00I_S_011				
L3N_R00I_S_012				

Call state R00, outgoing call				
ATS reference	Selected? (Y/N)	Run? (Y/N)	Verdict	Observations
L3N_R00O_V_001				
L3N_R00O_V_002				
L3N_R00O_V_003				
L3N_R00O_V_004				
L3N_R00O_V_005				
L3N_R00O_V_006				
L3N_R00O_V_007				
L3N_R00O_V_008				
L3N_R00O_I_001				
L3N_R00O_I_002				
L3N_R00O_I_003				
L3N_R00O_S_001				
L3N_R00O_S_002				
L3N_R00O_S_003				
L3N_R00O_S_004				
L3N_R00O_S_005				
L3N_R00O_S_006				
L3N_R00O_S_007				
L3N_R00O_S_008				
L3N_R00O_S_009				
L3N_R00O_S_010				
L3N_R00O_S_011				
L3N_R00O_S_012				

Call state R01				
ATS reference	Selected? (Y/N)	Run? (Y/N)	Verdict	Observations
L3N_R01_V_001				
L3N_R01_V_002				
L3N_R01_V_003				
L3N_R01_I_001				
L3N_R01_I_002				
L3N_R01_I_003				
L3N_R01_I_004				
L3N_R01_I_005				
L3N_R01_I_006				
L3N_R01_S_001				
L3N_R01_S_002				
L3N_R01_S_003				
L3N_R01_S_004				
L3N_R01_S_005				
L3N_R01_S_006				
L3N_R01_S_007				
L3N_R01_S_008				
L3N_R01_S_009				
L3N_R01_S_010				
L3N_R01_S_011				

Message Segmentation				
ATS reference	Selected? (Y/N)	Run? (Y/N)	Verdict	Observations
L3N_SEG_V_001				
L3N_SEG_V_002				
L3N_SEG_I_001				
L3N_SEG_I_002				
L3N_SEG_I_003				
L3N_SEG_I_004				
L3N_SEG_I_005				
L3N_SEG_I_006				
L3N_SEG_I_007				
L3N_SEG_S_001				

Annex B (normative): Partial PIXIT proforma

Notwithstanding the provisions of the copyright clause related to the text of this ETS, ETSI grants that users of this ETS may freely reproduce the partial PIXIT proforma in this annex so that it can be used for its intended purposes and may further publish the completed PIXIT.

B.1 Identification summary

PIXIT number:

.....

Test laboratory name:

.....

Date of issue:

.....

Issued to:

.....

B.2 Abstract test suite summary

Protocol specification: ETS 300 403-1

ATS specification: ETS 300 403-7

Abstract test method: Multi-party test method (see ISO/IEC 9646-2)

B.3 Test laboratory

Test laboratory identification:

.....

Accreditation status of the test service:

.....

Accreditation reference:

.....

Test laboratory manager:

.....

Test laboratory contact:

.....

Means of testing:

.....

Test laboratory instructions for completion:

.....

B.4 Client (of the test laboratory)

Client identification:

.....

Client test manager:

.....

Client contact:

.....

Test facilities required:

.....

B.5 System Under Test (SUT)

Name:

.....

Version:

.....

SCS reference:

.....

Machine configuration:

.....

Operating system identification:

.....

IUT identification:

.....

PICS (all layers):

.....

.....

Limitations of the SUT:

.....

Environmental conditions:

.....

B.6 Protocol information

B.6.1 Protocol identification

Specification reference: ETS 300 403-1

Protocol version:

PICS reference:

NOTE: The PICS reference should reference a completed PICS which is conformant with the PICS proforma contained in ETS 300 403-3.

B.6.2 Configuration to be tested

Table B.1: Configuration to be tested

Item	Configuration: Is the access to be tested ...	Supported? (Y/N)
1.1	sending a RESTART message after the establishment of the multiple frame operation?	
1.2	releasing the multiple frame established operation (i.e. sending of a DISC frame) after entering the state N00?	

B.6.3 Configuration options

Table B.2: Configuration options

Item	Configuration: What actions, if possible, have to be taken to configure the IUT to ...	Supported? (Y/N)	Stimulus (action taken)
2.1	send a RESTART message after the second timeout of timer T308?		
2.2	accept two calls on one CES?		
2.3	be in an all channels busy condition (i.e. send a RELEASE COMPLETE message indicating cause value 34 in response to a compatible SETUP message)?		
2.4	be in an all channels unavailable condition (i.e. send a RELEASE COMPLETE message indicating cause value 34 or 44 in response to a compatible SETUP message)?		
2.5	have a specific channel (as given in PIXIT item 5.25) unavailable?		
2.6	have a specific bearer service (as given in PIXIT item 5.11) unavailable or not authorized?		
2.7	remain in call state N02, but to route the call to the called user (called user's number as given in PIXIT item 5.22)?		

(continued)

Table B.2 (concluded): Configuration options

Item	Configuration: What actions, if possible, have to be taken to configure the IUT to ...	Supported? (Y/N)	Stimulus (action taken)
2.8	accept a SETUP message indicating a bearer service (as given in PIXIT item 5.12) but reject it after entering state N02?		
2.9	send a SETUP message indicating in the Channel identification information element "exclusive: only the indicated channel is acceptable"? (for point-to-point configuration only)		
2.10	send a SETUP message indicating in the Channel identification information element "indicated channel is preferred"? (for point-to-point configuration only)		
2.11	send a SETUP message indicating in the Channel identification information element "any channel"? (for point-to-point configuration only)		
2.12	have the access under test not subscribed to the call rearrangement procedures?		
2.13	send a DISCONNECT message including the Progress indicator information element (see PIXIT item 5.28)?		
2.14	send a DISCONNECT message NOT including the Progress indicator information element?		

B.6.4 Test management timers

Table B.3: Timer values

Item	Timer values: Give a value for the timer used to ...	Value (in seconds)
3.1	wait for the test operator to perform an implicit send action or to wait for a PTC to react (TWAIT).	
3.2	wait for the IUT to respond to a stimulus sent by the tester (TAC).	
3.3	control that the IUT does not respond to a stimulus sent by the tester (TNOAC).	
3.4	wait for RESTART messages after establishment of the multiple frame operation (T_RESTART; only if 1.1 is supported).	
NOTE:	The IUT provider may fill in a value range rather than a fixed value for the test management timers. During test execution the test laboratory will choose specific values for the timers dependant on the means of testing used. These specific values may even be beyond the range given by the IUT provider, if this is necessary for achieving satisfactory test results.	

B.6.5 Sending of messages by IUT

Table B.4: Actions required to stimulate IUT to send messages

Item	Action: What actions, if possible, have to be taken to cause the IUT to send a ...	Supported? (Y/N)	Stimulus (action taken)
4.1	INFORMATION message in call state N02?		
4.2	INFORMATION message in call state N03?		
4.3	INFORMATION message in call state N04?		
4.4	INFORMATION message in call state N07?		
4.5	INFORMATION message in call state N09?		
4.6	INFORMATION message in call state N10?		
4.7	INFORMATION message in call state N12?		
4.8	NOTIFY message in call state N10?		
4.9	PROGRESS message in call state N02?		
4.10	PROGRESS message in call state N03?		
4.11	PROGRESS message in call state N04?		
4.12	RESTART message in call state N10?		
4.13	DISCONNECT message with a length exceeding N201 (default value 260 octets) in call state N10?		

B.6.6 Parameter values

Table B.5: Parameter values

Item	Parameter values: Give a ...	Allowed values	Value
5.1	value for the maximum number of STATUS ENQUIRY retransmissions, if no STATUS message is received.	N/A	
5.2	value for an erroneous protocol discriminator, coded other than '00001000'B.	any other than '00001000'B	
5.3	value for an unrecognized message type.	N/A	
5.4	value for the supported length of the call reference value.	BA: 1 PRA: 2	
5.5	value for a length of the call reference value that is higher than the supported length.	BA: > 1 PRA: > 2	
5.6	a coding of a Bearer capability information element, which the IUT is compatible with, for the purpose of accepting outgoing calls.	N/A	
5.7	a coding of a Bearer capability information element (information transfer capability = "speech") for the purpose of accepting outgoing calls.	N/A	
5.8	a coding of a Bearer capability information element (information transfer capability = "unrestricted digital information") for the purpose of accepting outgoing calls.	N/A	

(continued)

Table B.5 (continued): Parameter values

Item	Parameter values: Give a ...	Allowed values	Value
5.9	a coding of a Bearer capability information element (information transfer capability = "3.1kHz Audio") for the purpose of accepting outgoing calls.	N/A	
5.10	a coding of a Bearer capability information element (information transfer capability = "unrestricted digital information with tones/announcements") for the purpose of accepting outgoing calls.	N/A	
5.11	a coding of a Bearer capability information element indicating a service that is accepted in a SETUP message but that will be rejected in N02 (see PIXIT item 2.6).	N/A	
5.12	a coding of a Bearer capability information element indicating a service that is not authorized or not available for the purpose of rejecting outgoing calls.	N/A	
5.13	a coding of a Bearer capability information element, for which fallback is allowed.	N/A	
5.14	a coding of a High layer compatibility information element, which the IUT is compatible with, for the purpose of accepting outgoing calls.	N/A	
5.15	a coding of a High layer compatibility information element, for which fallback is allowed.	N/A	
5.16	a coding of a Low layer compatibility information element, which the IUT is compatible with, for the purpose of accepting outgoing calls.	N/A	
5.17	a coding of a Called party number information element including the number digits of the access related to the PTC1.	N/A	
5.18	a coding of a Called party number information element including the number digits of the access related to the PTC2.	N/A	
5.19	a coding of a Called party number information element including the number digits of the access related to the MTC.	N/A	
5.20	the coding of a Called party number information element that will be sent by the IUT to the MTC in a en-bloc SETUP message.	N/A	
5.21	a coding of a Called party number information element, which contains number information that is incomplete (insufficient to route the call to its destination).	N/A	
5.22	a coding of a Called party number information element, which contains number information that is incomplete so that the IUT remains in state N02 but that is sufficient for the IUT to route the call to its destination (see PIXIT item 2.7).	N/A	

(continued)

Table B.5 (concluded): Parameter values

Item	Parameter values: Give a ...	Allowed values	Value
5.23	a coding of a Called party number information element, which contains invalid number information for the purpose of rejecting outgoing calls.	N/A	
5.24	a value for the preferred channel number (used in Channel identification information element) to be used for outgoing calls.	BA: 1..2 PRA: 1..30	
5.25	a value for the preferred channel number (used in Channel identification information element) to be used for a second outgoing call on the same CES (if PIXIT item 2.2 is supported).	BA: 1..2 PRA: 1..30	
5.26	a value for the a channel number (used in Channel identification information element), which is not available (see PIXIT item 2.5).	N/A	
5.27	a value for the a channel number (used in Channel identification information element), which is not subscribed. Tested only for primary rate access.	N/A	
5.28	a cause value that, when sent in a DISCONNECT message to the IUT will result in the sending of a DISCONNECT message including a Progress indicator information element at the remote user (see PIXIT item 2.13).	N/A	

Annex C (normative): Abstract Test Suite (ATS)

This ATS has been produced using the Tree and Tabular Combined Notation (TTCN) according to ISO/IEC 9646-3 [7].

The ATS was developed on a separate TTCN software tool and therefore the TTCN tables are not completely referenced in the contents table. The ATS itself contains a test suite overview part which provides additional information and references (see also annex D).

C.1 The TTCN Graphical form (TTCN.GR)

The TTCN.GR representation of this ATS is contained in a PDF file (403_7_2.pdf included in archive 4037_e1.lzh) which accompanies this ETS.

C.2 The TTCN Machine Processable form (TTCN.MP)

The TTCN.MP representation corresponding to this ATS is contained in an ASCII file (403_7_2.mp included in archive 4037_e1.lzh) which accompanies this ETS.

NOTE: According to ISO/IEC 9646-3 [7], in case of a conflict in interpretation of the operational semantics of TTCN.GR and TTCN.MP, the operational semantics of the TTCN.GR representation takes precedence.

Annex D (informative): General structure of ATS

This annex gives a simple listing of the order of types of tables which appear in a typical supplementary service ATS. This is intended as an aid in helping readers find particular sections quickly.

Test Suite Overview

Test Suite Structure

Test Case Index

Test Step Index

Default Index

Declarations Part

Simple Type Definitions

Structured Type Definitions

ASN.1 Type Definitions

Test Suite Operation Definitions

Test Suite Parameter Declarations

Test Case Selection Expression Definitions

Test Suite Constant Declarations

Test Case Variable Declarations

PCO Declarations

Co-ordination Point Declarations

Timer Declarations

Test Component Declarations

Test Components Configuration Declarations

TTCN ASP Type Definition

TTCN PDU Type Definition

TTCN CM Type Definition

Alias Definitions

Constraints Part

Structured Type Constraint Declarations

ASN.1 Type Constraint Declarations

TTCN ASP Constraint Declarations

TTCN PDU Constraint Declarations

TTCN CM Constraint Declarations

Dynamic Part

Test Case Dynamic Behaviour

Test Step Dynamic Behaviour

Default Dynamic Behaviour

History

Document history			
March 1997	Public Enquiry	PE 9729:	1997-03-21 to 1997-07-18
January 1998	Vote	V 9811:	1998-01-13 to 1998-03-13
April 1998	First Edition		