

EUROPEAN
TELECOMMUNICATION
STANDARD

DRAFT

ETS 300 394-4-6

December 1999

Source: TETRA

Reference: DE/TETRA-02009-4-6

ICS: 33.020

Key words: TETRA, DMO, protocol, testing, TTCN, ATS, radio

**Terrestrial Trunked Radio (TETRA);
Conformance testing specification;
Part 4: Protocol testing specification for
Direct Mode Operation (DMO);
Sub-part 6: Abstract Test Suite (ATS) for
Direct Mode Repeater (DM-REP) type 1**

ETSI

European Telecommunications Standards Institute

ETSI Secretariat

Postal address: F-06921 Sophia Antipolis CEDEX - FRANCE

Office address: 650 Route des Lucioles - Sophia Antipolis - Valbonne - FRANCE

Internet: secretariat@etsi.fr - <http://www.etsi.org>

Tel.: +33 4 92 94 42 00 - Fax: +33 4 93 65 47 16

Copyright Notification: No part may be reproduced except as authorized by written permission. The copyright and the foregoing restriction extend to reproduction in all media.

© European Telecommunications Standards Institute 1999. All rights reserved.

Contents

Foreword.....	5
1 Scope	7
2 References	7
3 Definitions and abbreviations	8
3.1 TETRA definitions	8
3.2 TETRA abbreviations	8
3.3 ISO 9646 definitions.....	8
3.4 ISO 9646 abbreviations.....	9
4 Abstract Test Method (ATM)	9
4.1 Single PCO testing.....	10
4.1.1 Lower Tester (LT).....	10
4.1.2 Upper Tester (UT)	10
4.1.3 Test Coordination Procedures (TCP)	10
4.1.4 Point of Control and Observation (PCO)	10
4.2 Multiple PCO testing	11
4.2.1 Lower Testers (LT)	11
4.2.2 Upper Tester (UT)	11
4.2.3 Test Coordination Procedures (TCP).....	11
4.2.4 Point of Control and Observation (PCO)	11
4.3 Test configurations and use of concurrent TTCN	12
5 ATS conventions	13
5.1 Naming conventions	13
5.1.1 Declarations part	13
5.1.1.1 Test suite type and structured type definitions.....	13
5.1.1.2 Test suite operations definitions	13
5.1.1.3 Test suite parameter declarations	13
5.1.1.4 Test case selection expression definitions	13
5.1.1.5 Test suite constant declarations	14
5.1.1.6 Test suite variable declarations	14
5.1.1.7 Test case variable declarations	14
5.1.1.8 PCO declarations.....	14
5.1.1.9 Timer declarations	14
5.1.1.10 ASP type definitions.....	15
5.1.1.11 PDU type definitions	15
5.1.1.12 Alias definitions	15
5.1.2 Constraints part	15
5.1.3 Dynamic part	16
5.1.3.1 Test case identifier.....	16
5.1.3.2 Test step identifier	16
5.1.3.3 Default identifier	16
5.2 Implementation conventions	16
5.3 TC and TP naming.....	16
Annex A (normative): ATS for DMO Repeater type 1 (DM-REP1) MAC layer	17
A.1 The TTCN Graphical form (TTCN.GR)	17
A.2 The TTCN Machine Processable form (TTCN.MP)	17
Annex B (normative): Partial PIXIT proforma for TETRA DMO Repeater type 1 MAC layer protocol ..	18

B.1	Identification summary.....	18
B.2	ATS summary.....	18
B.3	Test laboratory.....	18
B.4	Client identification.....	18
B.5	SUT.....	19
B.6	Protocol layer information.....	19
B.6.1	Protocol identification.....	19
B.6.2	IUT information.....	19
B.6.2.1	Implicit send events.....	19
B.6.2.2	Parameter values.....	19
Annex C (normative):	Protocol Conformance Test Report (PCTR) proforma for TETRA DMO Repeater type 1 MAC layer protocol.....	20
C.1	Identification summary.....	20
C.1.1	Protocol conformance test report.....	20
C.1.2	IUT identification.....	20
C.1.3	Testing environment.....	20
C.1.4	Limits and reservation.....	21
C.1.5	Comments.....	21
C.2	IUT conformance status.....	21
C.3	Static conformance summary.....	21
C.4	Dynamic conformance summary.....	21
C.5	Static conformance review report.....	22
C.6	Test campaign report.....	22
C.7	Observations.....	23
History	24

Foreword

This draft European Telecommunication Standard (ETS) has been produced by the Terrestrial Trunked Radio (TETRA) Project of the European Telecommunications Standards Institute (ETSI), and is now submitted for the Public Enquiry phase of the ETSI standards approval procedure.

This ETS consists of 5 parts as follows:

- Part 1: "Radio";
- Part 2: "Protocol testing specification for Voice plus Data (V+D)";
- Part 3: "Protocol testing specification for Packet Data Optimized (PDO)";
- Part 4: "Protocol testing specification for Direct Mode Operation (DMO)";**
- Part 5: "Security".

Proposed transposition dates	
Date of latest announcement of this ETS (doa):	3 months after ETSI publication
Date of latest publication of new National Standard or endorsement of this ETS (dop/e):	6 months after doa
Date of withdrawal of any conflicting National Standard (dow):	6 months after doa

Blank page

1 Scope

This ETS contains the Abstract Test Suite (ATS) to test the TETRA Direct Mode Operation (DMO) Repeater type 1 (DM-REP1) protocol at layer 2, the Medium Access Control (MAC) protocol. The MAC protocol is specified in ETS 300 396-3 [1] and in ETS 300 396-4 [2]. The Test Suite Structure (TSS) and Test Purposes (TPs) for this ATS are defined in ETS 300 394-4-4 [4].

The objective of this test specification is to provide a basis for approval tests for TETRA equipment giving a high probability of air interface inter-operability between different manufacturer's TETRA equipment.

The ISO standard for the methodology of conformance testing, ISO/IEC 9646-1 [5], ISO/IEC 9646-2 [6], ISO/IEC 9646-3 [7] and ISO/IEC 9646-5 [8], as well as the ETSI rules for conformance testing, ETS 300 406 [9] and ETR 141 [10] are used as a basis for the test methodology.

Annex A provides the Tree and Tabular Combined Notation (TTCN) part of this ATS.

Annex B provides the partial Protocol Implementation eXtra Information for Testing (PIXIT) Proforma of this ATS.

Annex C provides the Protocol Conformance Test Report (PCTR) Proforma of this ATS.

2 References

This ETS incorporates by dated and undated reference, provisions from other publications. These normative references are cited at the appropriate places in the text and the publications are listed hereafter. For dated references, subsequent amendments to or revisions of any of these publications apply to this ETS only when incorporated in it by amendment or revision. For undated references the latest edition of the publication referred to applies.

- [1] ETS 300 396-3: "Radio Equipment and Systems (RES); Trans-European Trunked RADio (TETRA) system; Direct Mode; Part 3: Mobile Station to Mobile Station (MS-MS) Air Interface (AI) protocol".
- [2] ETS 300 396-4: "Radio Equipment and Systems (RES); Trans-European Trunked Radio (TETRA); Direct Mode (DM); Part 4: Type 1 Repeater Air Interface".
- [3] ETS 300 396-8-2: "Radio Equipment and Systems (RES); Trans-European Trunked RADio (TETRA); Direct Mode Operation (DMO); Part 8: Protocol Implementation Conformance Statement (PICS) proforma specification; Part 8-2: Type 1 repeater Air Interface".
- [4] ETS 300 394-4-4: "Radio Equipment and Systems (RES); Trans-European Trunked RADio (TETRA) system; Direct Mode Operation (DMO); Part 4: Protocol testing specification; Test Suite Structure and Test Purposes; Part 4-4 Repeater type 1 (DM REP1) Air Interface (AI)".
- [5] ISO/IEC 9646-1 (1994): "Information technology - Open Systems Interconnection - Conformance Testing Methodology and Framework - Part 1: General Concepts". (See also CCITT Recommendation X.290 (1991)).
- [6] ISO/IEC 9646-2 (1994): "Information technology - Open Systems Interconnection - Conformance Testing Methodology and Framework - Part 2: Abstract Test Suite Specification". (See also CCITT Recommendation X.291 (1991)).
- [7] ISO/IEC 9646-3 (1994): "Information technology - Open Systems Interconnection - Conformance testing methodology and framework - Part 3: The tree and tabular combined notation". (See also CCITT Recommendation X.292 (1992)).

- [8] ISO/IEC 9646-5 (1994): "Information technology - Open Systems Interconnection - Conformance testing methodology and framework - Part 5: Requirements on test laboratories and clients for the conformance assessment process". (See also CCITT Recommendation X.292 (1992)).
- [9] ETS 300 406: "Methods for Testing and Specification (MTS); Protocol and profile conformance testing specifications; Standardization methodology".
- [10] ETR 141: "Methods for Testing and Specification (MTS); Protocol and profile conformance testing specifications; The Tree and Tabular Combined Notation (TTCN) style guide".

3 Definitions and abbreviations

3.1 TETRA definitions

For the purposes of this ETS, the definitions given in ETS 300 396-4 [2] apply.

3.2 TETRA abbreviations

For the purposes of this ETS the following TETRA abbreviations apply:

DM-REP1	Direct Mode Repeater Type 1
MAC	Medium Access Control
MS	Mobile Station
SDS	Short Data Service
SDU	Service Data Unit

3.3 ISO 9646 definitions

For the purposes of this ETS the following ISO/IEC 9646-1 [5] definitions apply:

ATS	Abstract Test Suite
ATM	Abstract Test Method
ICS	Implementation Conformance Statement
IUT	Implementation Under Test
IXIT	Implementation eXtra Information for Testing
LT	Lower Tester
PCO	Point of Control and Observation
PICS	Protocol Implementation Conformance Statement (PICS proforma)
PIXIT	Protocol Implementation eXtra Information for Testing (PIXIT proforma)
SAP	Service Access Point
SpyT	Single Party Testing
SUT	System Under Test
UT	Upper Tester

For the purposes of this ETS the following ISO/IEC 9646-3 [7] definitions apply:

TTCN.GR
TTCN.MP

For the purposes of this ETS the following ISO/IEC 9646-5 [8] definition applies:

PCTR Protocol Conformance Test Report (PCTR proforma)

3.4 ISO 9646 abbreviations

For the purposes of this ETS the following ISO/IEC 9646-1 [5] abbreviations apply:

ASP	Abstract Service Primitive
ATM	Abstract Test Method
ATS	Abstract Test Suite
IUT	Implementation Under Test
LT	Lower Tester
PCO	Point of Control and Observation
PDU	Protocol Data Unit
PICS	Protocol Implementation Conformance Statements
PIXIT	Protocol Implementation eXtra Information for Testing
SAP	Service Access Point
SPyT	Single Party Testing
SUT	System Under Test
TC	Test Case
TP	Test Purpose
TTCN	Tree and Tabular Combined Notation
TSS	Test Suite Structure
UT	Upper Tester

For the purposes of this ETS the following ISO/IEC 9646-5 [8] abbreviation applies:

PCTR	Protocol Conformance Test Report
------	----------------------------------

4 Abstract Test Method (ATM)

This clause describes the ATM used for testing the DM-REP1 MAC layer protocol. The selected method is the remote method, as defined in ISO/IEC 9646-2 [6], clause 11. This test method has been selected, because:

- this test method implies no specific requirements from the Implementation Under Test (IUT);
- the upper Service Access Point (SAP) of the IUT cannot be directly observed;
- the variety of the possible TETRA implementations is a serious technical obstacle for the adoption of a different ATM;
- this test method places minimum limitations in the realization of conformance testing.

The DM-REP1 MAC protocol defines the operation of a DM-REP1 serving two air interfaces, the master and the slave link. To test the repeater operation in some cases both interfaces need to be controlled and observed simultaneously. This implies that two testing methods are used: the remote single-party test method (with one PCO) and the remote multiparty test method with two PCOs.

4.1 Single PCO testing

The remote Single Party test method with a single PCO is illustrated in figure 1.

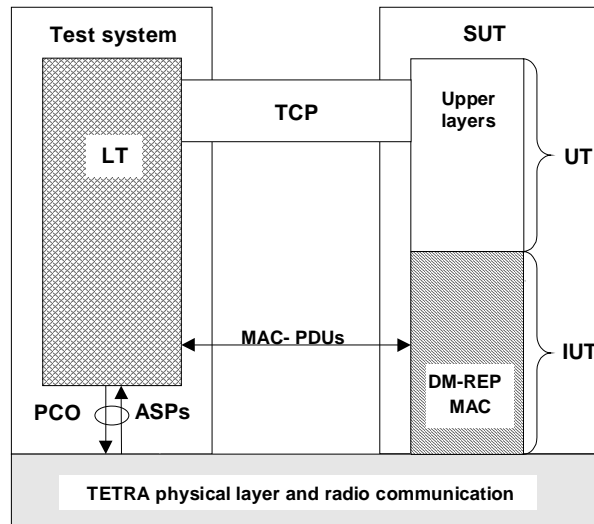

Figure 1: Remote SPyT test method for TETRA DM-REP1 MAC layer

4.1.1 Lower Tester (LT)

A LT is located in a remote TETRA test system. It controls and observes the behaviour of the IUT.

4.1.2 Upper Tester (UT)

There is no explicit UT in the remote test method, but the DM-REP1 MAC layer and the layers above inside the System Under Test (SUT) are used implicitly for testing the MAC layer.

4.1.3 Test Coordination Procedures (TCP)

The implicit send events defined by the provider of an implementation in annex B serve the purpose of the TCP. They are used as an input to the IUT communicating with the UT to initiate test events at the DMO MAC layer.

4.1.4 Point of Control and Observation (PCO)

All test events at the PCO carrying service user data are specified in terms of MAC layer PDUs. Only few Abstract Service Primitives (ASPs) are defined for control or observation purposes. The mapping of the MAC PDUs into the physical layer frame structure is left to the test implementation.

4.2 Multiple PCO testing

The selected test method is illustrated in figure 2.

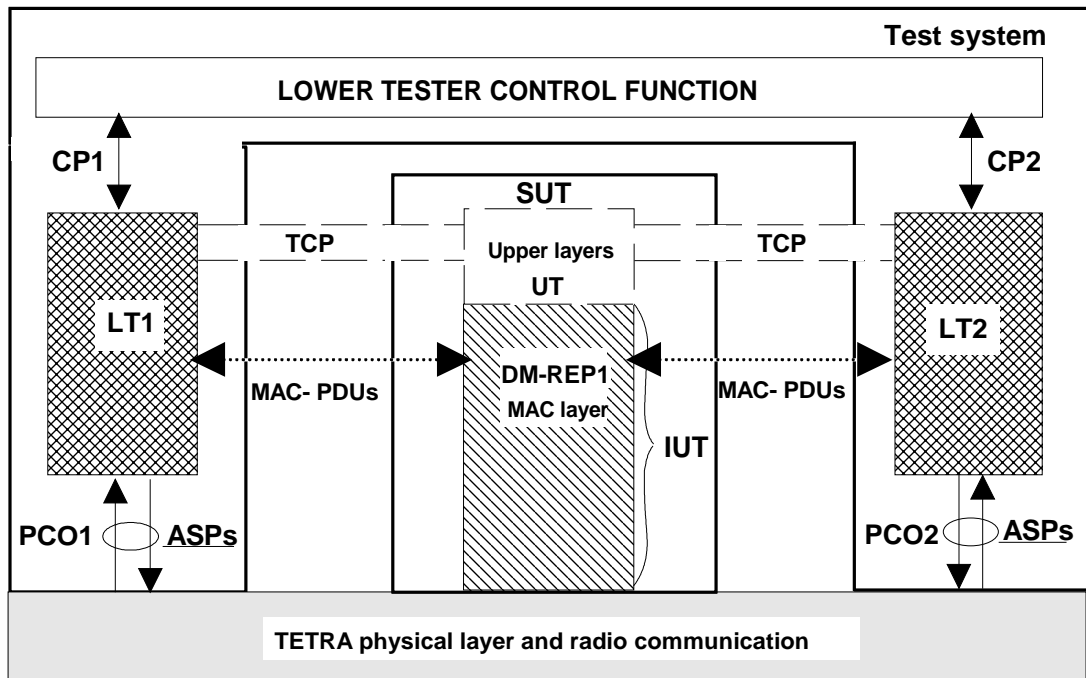

Figure 2: Remote multi party test method for TETRA DM-REP1 MAC protocol

4.2.1 Lower Testers (LT)

Two LTs: LT1 and LT2 are located in a remote TETRA test system. They observe the behaviour of the IUT. They are controlled and synchronized by the lower tester control function.

4.2.2 Upper Tester (UT)

There is no explicit UT in the remote test method, but the layers above inside the System Under Test (SUT) are used implicitly for testing the DM-REP1 MAC layer.

4.2.3 Test Coordination Procedures (TCP)

The implicit send events defined by the provider of an implementation in annex B serve the purpose of the TCP. They are used as an input to the IUT communicating with the UT to initiate test events at the MAC protocol layer.

4.2.4 Point of Control and Observation (PCO)

The PCOs are located inside the protocol.

All test events at the PCOs carrying service user data are specified in terms of MAC PDUs. The mapping of the PDUs to possible physical layer service primitives is left to the test implementation.

4.3 Test configurations and use of concurrent TTCN

As this ATS covers both single-party testing using non-concurrent TTCN, and multi-party testing using concurrent TTCN, the notation chosen for the complete ATS is concurrent TTCN syntax. Therefore, tests components are defined to describe the two configurations: the "single_party" configuration and the "multi_party" configuration, as shown in Figures 3 and 4.

The single_party configuration is used in case of single-party testing, i.e. for testing a single air interface only, a master link or slave link interface. In this case only a single test component is needed. It is the Main Test Component (MTC) MTC_SINGLE connected to the IUT via the PCO LMAC.

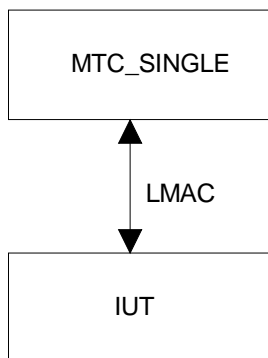

Figure 3: Single_party configuration

The Multi_party configuration is used when testing the DM-REP1 MAC layer protocol involves both the master link and slave link interface. In this case, three test components are needed. These are the Main Test Component (MTC) MTC_REP1, and the two Parallel Test Components (PTCs) PTC_MS_ML and PTC_MS_SL. The two PTCs are connected to the MTC via the coordination points CP_ML and CP_SL. The PTC_MS_ML and PTC_MS_SL are further connected to the IUT via the two PCOs LMAC_ML and LMAC_SL.

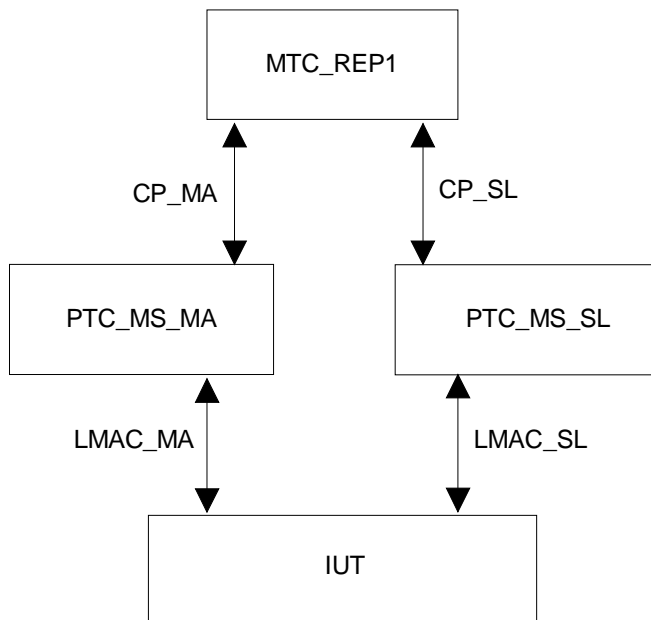

Figure 4: Multi_party configuration for DM-REP1 MAC testing

5 ATS conventions

This clause describes the conventions applied to define the ATS and gives the naming conventions chosen for the different elements of the ATS.

The ATS conventions are intended to give a better understanding of the ATS but they describe also the conventions made for the development of the ATS, thus for any later maintenance purposes or further development of the ATS, the conventions described in this clause shall be considered.

5.1 Naming conventions

5.1.1 Declarations part

This subclause describes the naming conventions chosen for the elements of the ATS declarations part.

5.1.1.1 Test suite type and structured type definitions

The test suite type and test suite structured type identifiers describe the information elements, and each whole word included in the name is written in lowercase starting by an uppercase letter:

EXAMPLE:	CallOwnershipType	simple type;
	SSI_Type	simple type;
	ITSI_Type	structured type.

In the case an abbreviation is included in the declaration name, there is an underscore ("_") before and/or after it, separating it from the rest of the identifier. This rule with abbreviations apply to all the naming conventions in the whole test suite.

5.1.1.2 Test suite operations definitions

The test suite operation identifiers are composed of strings in uppercase letters starting by the uppercase string "TSO_". The different strings in the definition are separated with underscores.

EXAMPLE: TSO_RADIO_LINK_FAILURE.

5.1.1.3 Test suite parameter declarations

The test suite parameter identifiers are composed of strings in uppercase letters starting by the uppercase string "PIC_" or "PIX_" and separated by underscores.

If the test suite parameter references a PICS item, the prefix "PIC_" is used.

EXAMPLE 1: PIC_CM_CALL.

If the test suite parameter references a PIXIT item, the prefix "PIX_" is used.

EXAMPLE 2: PIX_MS_ITSI.

Complete names as defined in the specifications are used.

5.1.1.4 Test case selection expression definitions

The naming conventions for the test case selection expression definitions use free text starting with an uppercase letter. The name of the expression shall explain clearly the selection rule. The test case selection expressions are generally logical combinations of the PICS element definitions.

5.1.1.5 Test suite constant declarations

The test suite constant identifiers are composed of strings in lowercase letters starting by the lowercase string "tsc_".

EXAMPLE: tsc_slot_1;

 tsc_initial_frame_number.

Complete names as defined in the specifications are used. However, in the parameters including a dot character, the dot is replaced by an underscore.

5.1.1.6 Test suite variable declarations

The test suite variable identifiers are composed of string in lowercase letters starting by the lowercase string "tsv_".

EXAMPLE: tsv_call_active.

If the test suite variable represents a system parameter or value, the name defined in the specifications is used. However, in the variables including a dot character, the dot is replaced by an underscore.

5.1.1.7 Test case variable declarations

The test case variable identifiers are composed of strings in lowercase letters starting by the lowercase string "tcv_".

EXAMPLE: tcv_energy_economy_group.

5.1.1.8 PCO declarations

The point of control and observation identifiers are composed of three to six capital letters, beginning with an "L", as there are only LTs.

EXAMPLE: LMAC_SL Represents a lower tester MAC PCO.

5.1.1.9 Timer declarations

Two kinds of timers can be distinguished:

1) standardized:

 Those defined in the standard, e.g. DT303, use the same name as in the standard, beginning with capital "DT".

As there is a tolerance margin accepted for these timers, two values are needed:

- the minimum value allowed, which will use the suffix "_Min";
- the maximum value allowed, which will use the suffix "_Max".

EXAMPLE 1: DT303_Min, DT303_Max

2) non-standardized:

 Those not defined in the standard, i.e. for execution use, e.g. a timer waiting for a response. These timers begin with the prefix "T_", followed by a string in lowercase letters with each word in the following string starting with an uppercase letter.

EXAMPLE 2: T_IUT_Response

 T_NoResponse

5.1.1.10 ASP type definitions

ASP definitions follow the specification in the ETS 300 396-4 [2] when a corresponding definition exists. If not, a free name is used.

EXAMPLE: LINK_indication

 RESET_MS.

5.1.1.11 PDU type definitions

The identifier of a PDU is given in a string in uppercase letters, which represents the layer message.

EXAMPLE: DM_SETUP for the SETUP layer 3 PDU;

 DMAC_FRAG_PDU_Type for the DMAC FRAC layer 2 PDU.

5.1.1.12 Alias definitions

No alias definitions are used in the test suite.

5.1.2 Constraints part

This subclause describes the naming conventions chosen for the elements of the ATS constraints part.

Constraint identifiers commence with uppercase. The remaining part of the name is separated from the beginning with an underscore and is written in lowercase with each word starting with an uppercase letter.

Identifier names of elements concerning the same subject have equivalent names in the declaration and the constraint part:

- Declaration part: U_STATUS;
- Constraint part: U_STATUS_IgnoreAll.

The name of the modified constraint describes the particularity of the modified constraint:

EXAMPLE 1: D_LOCATION_UPDATE_ACCEPT_HomeNetwork.

If formal parameter lists are used, the variable names are written in lowercase. The variable name is the same as the name of the element it is representing starting with prefix "cpa_".

EXAMPLE 2: U_STATUS_No_EG(cpa_Status: StatusType).

5.1.3 Dynamic part

This subclause describes the naming conventions chosen for the elements of the ATS dynamic part.

5.1.3.1 Test case identifier

The identifier of a TC is built according to the test purpose name, as in table 1.

Table 1: TC naming convention

DMO/<ts>/<fm>/<x>/<ss>/<nn>			
<ts>	= test suite type	DMREP1	Repeater type 1
<fm>	= functional module	MAC	Upper MAC (layer 2)
x	= Type of testing	CA	Capability Tests
		BV	Valid Behaviour Tests
		BI	Invalid Behaviour Tests
		TI	Timer expiry and counter mismatch tests
<nn>	= sequential number	01-99	Test Purpose Number

5.1.3.2 Test step identifier

The test step identifier is built with a string of lowercase letters leaded by a string of capital letter and joined by an underscore character. The first string indicates the main function of the test step; e.g. PRE for preamble, PST for postamble, LTS for local tree name and STP for general step. The second string indicates the meaning of the step.

EXAMPLES: PRE_Name;
 PST_Name;
 LTS_Name;
 STP_Name.

5.1.3.3 Default identifier

The default identifier MAC_OtherwiseFail is used. For the multi party configuration the identifiers DEF_mtc, DEF_ptc_ml, and DEF_ptc_sl are also used.

5.2 Implementation conventions

A fully functional underlying physical layer is assumed from the test system.

5.3 TC and TP naming

There is a single name used for both the TC identifiers and the TP identifiers.

Annex A (normative): ATS for DMO Repeater type 1 (DM-REP1) MAC layer

The ATS is written in TTCN according to ISO/IEC 9646-3 [7].

The ATS itself contains a test suite overview part which provides additional information and references.

A.1 The TTCN Graphical form (TTCN.GR)

The TTCN.GR representation of this ATS is contained in an Adobe Portable Document Format™ file (dmrep1.PDF contained in archive 39446e1.ZIP) which accompanies this ETS.

A.2 The TTCN Machine Processable form (TTCN.MP)

The TTCN.MP representation corresponding to this ATS is contained in an ASCII text file (dmrep1.MP contained in archive 39446e1.ZIP) which accompanies this ETS.

Annex B (normative): Partial PIXIT proforma for TETRA DMO Repeater type 1 MAC layer protocol

Notwithstanding the provisions of the copyright clause related to the text of this ETS, ETSI grants that users of this ETS may freely reproduce the PIXIT proforma in this annex so that it can be used for its intended purposes and may further publish the completed PIXIT.

The PIXIT proforma is based on ISO/IEC 9646-5. Any additional information needed can be found in this international standard document.

B.1 Identification summary

Table B.1

PIXIT number:	
Test laboratory name:	
Date of issue:	
Issued to:	

B.2 ATS summary

Table B.2

Protocol specification:	ETS 300 396-4.
Protocol to be tested:	
ATS specification:	ETS 300 394-4-6.
Abstract test method:	Remote test method, embedded variant.

B.3 Test laboratory

Table B.3

Test laboratory identification:	
Test laboratory manager:	
Means of testing:	
SAP address:	

B.4 Client identification

Table B.4

Client identification:	
Client test manager:	
Test facilities required:	

B.5 SUT

Table B.5

Name:	
Version:	
SCS number:	
Machine configuration:	
Operating system identification:	
IUT identification:	
PICS reference for IUT:	
Limitations of the SUT:	
Environmental conditions:	

B.6 Protocol layer information

B.6.1 Protocol identification

Table B.6

Name:	TETRA - DMO - Repeater type 1 Air Interface ETS 300 396-4.
Version:	
PICS references:	ETS 300 396-8-2.

B.6.2 IUT information

B.6.2.1 Implicit send events

None are used.

B.6.2.2 Parameter values

Table B.7 Parameter values

Item	Parameter	Parameter type	Explanation	Value or reference
1	PIX_CIRCUIT_M ODE_TYPE	Circuit_Mode_Type _Type	Traffic channel type and interleaving depth supported by the IUT.	
2	PIX_MNI	MNI_Type	MNI to be used by the tester.	
3	PIX_MS_MASTER _SSI	SSI_Type	SSI of an MS operating on the master link.	
4	PIX_MS_SLAVE_ SSI	SSI_Type	SSI of an MS operating on the slave link.	
5	PIX_POWER_CL ASS	Power_Class_Type	Power class of the tester as required by the IUT.	
6	PIX_POWER_CO NTROL_FLAG	Power_Control_Flag _Type	Power control flag as required by the IUT.	
7	PIX_REPEATER_ ADDRESS	Repeater_Address_ Type	Repeater address of the IUT.	
8	PIC_NON_REPEA TER_ADDRESS	Repeater_Address_ Type	An SSI not recognized as the repeater address of the IUT.	

Annex C (normative): Protocol Conformance Test Report (PCTR) proforma for TETRA DMO Repeater type 1 MAC layer protocol

Notwithstanding the provisions of the copyright clause related to the text of this ETS, ETSI grants that users of this ETS may freely reproduce the PCTR proforma in this annex so that it can be used for its intended purposes and may further publish the completed PCTR.

The PCTR Proforma is based on ISO/IEC 9646-5. Any additional information needed can be found in this referenced document.

C.1 Identification summary

C.1.1 Protocol conformance test report

Table C.1

PCTR number:	
PCTR date:	
Test laboratory identification:	
Accreditation status:	
Accreditation reference:	
Technical authority:	
Signature:	
Test laboratory manager:	
Signature:	

C.1.2 IUT identification

Table C.2

Name:	
Version:	
Protocol specification:	
PICS:	
Previous PCTR if any:	

C.1.3 Testing environment

Table C.3

PIXIT number:	
ATS specification:	
Abstract test method:	Remote test method, embedded variant.
Means of testing identification:	
Period of testing:	
Conformance log reference(s):	
Retention date for log reference(s):	

C.1.4 Limits and reservation

Additional information relevant to the technical contents or further use of the test report, or the rights and obligations of the test laboratory and the client, may be given here. Such information may include restriction on the publication of the report.

.....
.....
.....
.....
.....

C.1.5 Comments

Additional comments may be given by either the client or the test laboratory on any of the contents of the PCTR, for example, to note disagreement between the two parties.

.....
.....
.....
.....
.....

C.2 IUT conformance status

This IUT has or has not been shown by conformance assessment to be non-conforming to the specified protocol specification.

Strike the appropriate words in this sentence. If the PICS for this IUT is consistent with the static conformance requirements as specified in clause C.3 in this report and there are no "FAIL" verdicts to be recorded in clause C.6 strike the words "has or". otherwise strike the words "or has not".

C.3 Static conformance summary

The PICS for this IUT is or is not consistent with the static conformance requirements in the specified protocol.

Strike the appropriate words in this sentence.

C.4 Dynamic conformance summary

The test campaign did or did not reveal errors in the IUT.

Strike the appropriate words in this sentence. If there are no "FAIL" verdicts to be recorded in clause C.6 of this report strike the words "did or" otherwise strike the words "or did not".

Summary of the results of groups of test:

.....
.....
.....
.....
.....

C.5 Static conformance review report

If clause C.3 indicates non-conformance, this subclause itemizes the mismatches between the PICS and the static conformance requirements of the specified protocol specification.

.....

.....

.....

.....

.....

.....

.....

.....

.....

.....

.....

.....

.....

.....

.....

.....

.....

.....

.....

.....

C.6 Test campaign report

Table C.4

ATS reference	Selected	Run	Verdict	Observations (see note)
DMO_DMREP1_MAC_CA_01	Yes/No	Yes/No		
DMO_DMREP1_MAC_CA_02	Yes/No	Yes/No		
DMO_DMREP1_MAC_BV_01	Yes/No	Yes/No		
DMO_DMREP1_MAC_BV_02	Yes/No	Yes/No		
DMO_DMREP1_MAC_BV_03	Yes/No	Yes/No		
DMO_DMREP1_MAC_BV_04	Yes/No	Yes/No		
DMO_DMREP1_MAC_BV_05	Yes/No	Yes/No		
DMO_DMREP1_MAC_BV_06	Yes/No	Yes/No		
DMO_DMREP1_MAC_BV_07	Yes/No	Yes/No		
DMO_DMREP1_MAC_BV_08	Yes/No	Yes/No		
DMO_DMREP1_MAC_BV_09	Yes/No	Yes/No		
DMO_DMREP1_MAC_BV_10	Yes/No	Yes/No		
DMO_DMREP1_MAC_BI_01	Yes/No	Yes/No		
DMO_DMREP1_MAC_BI_02	Yes/No	Yes/No		
DMO_DMREP1_MAC_TI_01	Yes/No	Yes/No		
DMO_DMREP1_MAC_TI_02	Yes/No	Yes/No		
DMO_DMREP1_MAC_TI_03	Yes/No	Yes/No		
NOTE: Reference to any observations made in clause C.7 in this report.				

C.7 Observations

Additional information relevant to the technical content of the PCTR are given here.

.....
.....
.....
.....
.....
.....
.....
.....
.....
.....

History

Document history	
December 1999	Public Enquiry PE 200013: 1999-12-01 to 2000-03-31