



EUROPEAN
TELECOMMUNICATION
STANDARD

DRAFT
pr **ETS 300 394-1**

January 1995

Source: ETSI TC-RES

Reference: DE/RES-06009-1

ICS: 33.060

Key words: TETRA, radio conformance testing

**Radio Equipment and Systems (RES);
Trans-European Trunked Radio (TETRA)
Conformance testing specification
Part 1: Radio**

ETSI

European Telecommunications Standards Institute

ETSI Secretariat

Postal address: F-06921 Sophia Antipolis CEDEX - FRANCE

Office address: 650 Route des Lucioles - Sophia Antipolis - Valbonne - FRANCE

X.400: c=fr, a=atlas, p=etsi, s=secretariat - **Internet:** secretariat@etsi.fr

Tel.: +33 92 94 42 00 - Fax: +33 93 65 47 16

Copyright Notification: No part may be reproduced except as authorized by written permission. The copyright and the foregoing restriction extend to reproduction in all media.

© European Telecommunications Standards Institute 1995. All rights reserved.

Contents

Foreword		7
1	Scope	9
2	Normative references	9
3	Definitions, symbols and abbreviations	9
3.1	Definitions	9
3.2	Symbols	9
3.3	Abbreviations	10
4	General	10
4.1	Presentation of equipment for testing purposes	10
4.1.1	Facilities and information required for testing	10
4.1.2	Choice of radio frequency channels to be tested	11
4.1.3	Interpretation of the measurement results	11
4.2	Mechanical and electrical design	11
4.2.1	General	11
4.2.2	Controls	11
4.2.3	Marking	11
5	Radio test configuration, test signals and test modes	12
5.1	General functional radio test configuration	12
5.2	Radio test modes	12
5.2.1	Test receive mode	12
5.2.1.1	MS test receive mode	12
5.2.1.2	BS test receive mode	12
5.2.2	Test transmit mode	14
5.2.2.1	MS V+D testing	14
5.2.2.2	MS PDO testing	14
5.2.2.3	BS V+D & PDO testing	14
5.3	Radio test signals	14
5.3.1	General	14
5.3.2	Test signal T1 (TETRA wanted signal)	15
5.3.2.1	MS V+D testing	15
5.3.2.2	BS V+D testing	16
5.3.2.3	MS PDO testing	16
5.3.2.4	BS PDO testing	17
5.3.3	Test signal T2 (TETRA interferer)	17
5.3.4	Test signal T3 (unmodulated interferer)	17
6	Test conditions	17
6.1	General	17
6.2	Power sources and ambient temperatures	17
6.2.1	Normal test conditions	17
6.2.2	Extreme test conditions	18
6.3	Procedure for tests at extreme temperatures	19
6.3.1	Equipment designed for continuous operation	19
6.3.2	Equipment designed for intermittent operation	19
7	Technical characteristics	19
7.1	Transmitter parameter definitions & limits	19
7.1.1	Transmitter output power	19
7.1.1.1	Definition	19
7.1.1.2	Limit values	20
7.1.2	Unwanted output power in non-active transmit state	20
7.1.2.1	Definition	20

	7.1.2.2	Limit values	20
7.1.3	Adjacent channel power due to modulation		20
	7.1.3.1	Definition	20
	7.1.3.2	Limit values	21
7.1.4	Adjacent channel power due to switching transients		21
	7.1.4.1	Definition	21
	7.1.4.2	Limit values	21
7.1.5	Unwanted emissions far from the carrier		21
	7.1.5.1	Definition	21
	7.1.5.2	Limit values	21
7.1.6	Unwanted emissions during the BLCH/CLCH (linearisation).....		22
	7.1.6.1	Definition	22
	7.1.6.2	Limit values	22
7.1.7	Intermodulation attenuation		22
	7.1.7.1	Definition	22
	7.1.7.2	Limit values	22
		7.1.7.2.1	MS Limit values.....
		7.1.7.2.2	Limit values for single BS transmitter... 22
		7.1.7.2.3	Limit values for Intra BS intermodulation.....
			23
7.2	Receiver parameter definitions and limits		23
7.2.1	General		23
7.2.2	Nominal error rates		23
	7.2.2.1	Definition	23
	7.2.2.2	Limit values	23
7.2.3	Reference sensitivity performance		24
	7.2.3.1	Definition	24
	7.2.3.2	Limit values	24
7.2.4	Reference interference performance.....		24
	7.2.4.1	Definition	24
	7.2.4.2	Limit values	24
7.2.5	Blocking characteristics		25
	7.2.5.1	Definition	25
	7.2.5.2	Limit values	25
7.2.6	Spurious response rejection		25
	7.2.6.1	Definition	25
	7.2.6.2	Limit values	25
7.2.7	Intermodulation		26
	7.2.7.1	Definition	26
	7.2.7.2	Limit values	26
7.2.8	Unwanted emissions.....		26
	7.2.8.1	Definition	26
	7.2.8.2	Limit values	26
7.3	Transmitter / receiver parameter definitions & limits.....		27
7.3.1	Modulation accuracy.....		27
	7.3.1.1	Definition	27
	7.3.1.2	Limit values	27
7.3.2	Carrier frequency accuracy.....		27
	7.3.2.1	Definition	27
	7.3.2.2	Limit values	27
7.3.3	MS receiver performance for synchronization burst acquisition		27
	7.3.3.1	Definition	27
	7.3.3.2	Limit values	27
7.3.4	MS Frame alignment performance.....		28
	7.3.4.1	Definition	28
	7.3.4.2	Limit values	28
7.3.5	MS link control		28
	7.3.5.1	Definition	28
	7.3.5.2	Limit values	28
8	Methods of measurement for transmitter parameters		29
8.1	Transmitter output power		29
	8.1.1	MS transmitter output power.....	29

8.1.2	BS transmitter output power.....	29
8.2	Unwanted output power in non active transmit state	30
8.3	Adjacent channel power due to modulation	30
8.4	Adjacent channel power due to switching transients	31
8.5	Unwanted emissions far from the carrier.....	31
8.6	Unwanted emissions during the BLCH/CLCH (linearisation).....	31
8.7	Intermodulation attenuation	32
8.7.1	MS Intermodulation attenuation	32
8.7.2	BS Intermodulation attenuation	32
8.7.3	Intra BS intermodulation.....	32
9	Methods of measurement for receiver parameters.....	32
9.1	Nominal error rates	32
9.1.1	MS nominal error rate.....	32
9.1.2	BS nominal error rate	33
9.2	Reference sensitivity performance	33
9.2.1	MS reference sensitivity performance	33
9.2.2	BS reference sensitivity performance.....	33
9.2.3	PUEM performance.....	34
9.3	Reference interference performance.....	34
9.3.1	MS reference interference performance	34
9.3.2	BS reference interference performance	34
9.4	Blocking characteristics	35
9.4.1	MS blocking.....	35
9.4.2	BS blocking	35
9.5	Spurious response rejection	35
9.6	Intermodulation	36
9.6.1	MS intermodulation	36
9.6.2	BS intermodulation	36
9.7	Unwanted emissions.....	36
10	Methods of measurement for transmitter/receiver parameters.....	37
10.1	Modulation accuracy	37
10.1.1	MS modulation accuracy	37
10.1.2	BS modulation accuracy.....	37
10.1.3	Vector error magnitude at symbol time	37
10.1.4	Vector error magnitude between symbol times.....	37
10.2	Carrier frequency accuracy.....	38
10.2.1	MS carrier frequency accuracy.....	38
10.2.2	BS carrier frequency accuracy	38
10.3	MS receiver performance for synchronization burst acquisition	39
10.4	MS Frame alignment performance	39
10.5	MS link control	40
11	Measurement uncertainty.....	41
Annex A (normative): TETRA receiver testing		42
A.1	Frequencies of spurious response	42
A.1.1	Spurious response rejection	42
A.1.1.1	Definition	42
A.1.1.2	Introduction to the method of measurement	42
A.2	Test cases and test conditions for BS and MS receivers.....	43
A.3	Test signal T1, content of BSCH and BNCH/T (V+D) & MBCH/T (PDO)	53
Annex B (normative): Radio test system functions		55
B.1	Test transmitter and receiver	55
B.1.1	General	55
B.1.2	Sampling system.....	55
B.1.2.1	General.....	55

B.1.2.2	Adjacent channel power measurements	55
B.1.2.3	Modulation accuracy measurements	55
B.1.2.4	Measurement of unwanted output power in the nonactive transmit state	56
B.1.3	Spectrum analyzer	56
B.1.4	Error rate tester	56
B.1.5	Interfering signal sources	56
B.1.6	Propagation simulators	57
B.1.7	Timing measurement unit	57
B.1.8	Passive test system components	57
B.1.9	Test system controller	57
B.1.10	Test signal (T1, T2) requirements	57
B.1.10.1	Adjacent channel power	57
B.1.10.2	Modulation accuracy	57
History		59

Foreword

This draft European Telecommunication Standard (ETS) has been produced by the Radio Equipment and Systems (RES) Technical Committee of the European Telecommunications Standards Institute (ETSI), and is now submitted for the Public Enquiry phase of the ETSI standards approval procedure.

Every ETS prepared by ETSI is a voluntary standard. This ETS contains text concerning conformance testing of the equipment to which it relates. This text should be considered only as guidance and does not make this ETS mandatory.

Proposed transposition dates	
Date of latest announcement of this ETS (doa):	3 months after ETSI publication
Date of latest publication of new National Standard or endorsement of this ETS (dop/e):	6 months after doa
Date of withdrawal of any conflicting National Standard (dow):	6 months after doa

Blank page

1 Scope

This ETS specifies the minimum technical characteristics of both TETRA Voice + Data (V+D) and Packet Data Optimised (PDO) base and mobile station equipment and the radio test methods used for type testing. The purpose of these specifications is to provide a sufficient quality of radio transmission and reception for equipment operating in a TETRA system and to minimise harmful interference to other equipment. The document is applicable to TETRA systems operating at radio frequencies in the range of 380 MHz to 520 MHz.

These specifications do not necessarily include all the characteristics which may be required by a user of equipment, nor do they necessarily represent the optimum performance achievable.

2 Normative references

This ETS incorporates by dated and undated reference, provisions from other publications. These normative references are cited at the appropriate places in the text and the publications are listed hereafter. For dated references, subsequent amendments to or revisions of any of these publications apply to this ETS only when incorporated in it by amendment or revision. For undated references the latest edition of the publication referred to applies.

- [1] ETS 300 392-2 (1994): "Radio Equipment and Services (RES); Trans-European Trunked RAdio (TETRA) system; Voice plus Data; Part 2: Air Interface".
- [2] ETS 300 393-2 (1994): "Radio Equipment and Services (RES); Trans-European Trunked RAdio (TETRA) system; Packet Data Optimised; Part 2: Air Interface".
- [3] ETS 300 113 (1992): "Radio Equipment and Systems (RES); Land mobile service, Technical characteristics and test conditions for non-speech and combined analogue speech/non-speech equipment with an internal or external antenna connector, intended for the transmission of data".
- [4] CCITT Recommendation O.153: "Basic parameters for the measurement of error performance at bit rate below the primary rate".

3 Definitions, symbols and abbreviations

3.1 Definitions

For the purposes of this ETS, the following definitions apply:

Refer to ETS 300 392-2, [1] clause 3 for common definitions.

accreditation authority: The body which is concerned with approving the equipment based upon the results of the test authority.

test authority: That body which is concerned with the testing of equipment submitted by a manufacturer for approval.

test laboratory: A body which performs testing on the equipment. This laboratory is accredited to perform 3rd party testing.

3.2 Symbols

For the purposes of this ETS, the following symbols apply:

f _{lo}	local oscillator frequency applied to first receiver mixer
f _o	nominal centre frequency of radio channel
if ₁ ...if _n	receiver intermediate frequencies
P _{MS}	access power
P _{Tx}	MS transmit power
R _{lev}	averaged signal level received by MS

3.3 Abbreviations

For the purposes of this ETS, the following abbreviations apply:

Refer to ETS 300 392-2 [1], clause 3 for common abbreviations.

B	Measurement bandwidth
BER	Bit Error Rate
C/I	Carrier to Interference ratio
dBc	Decibels relative to carrier power
dBm	Decibels relative to one milliwatt
MER	Message Erasure Rate
PACQ	Probability of synchronisation burst Acquisition
PRBS	Pseudo Random Bit Sequence
PUEM	Probability of Undetected Erroneous Message
RF	Radio Frequency
RMS	Root Mean Square
Rx	Receiver
SB	Synchronization Burst
Tx	Transmitter
VSWR	Voltage Standing Wave Ratio

4 General

4.1 Presentation of equipment for testing purposes

Each equipment submitted for type testing shall fulfil the requirements of this ETS on all channels over which it is intended to operate. The manufacturer, or other applicant, shall provide one or more production model(s) of the equipment, as appropriate, for type testing. If type approval is given on the basis of tests on a preliminary model, then the corresponding production models shall be identical in all respects with the preliminary model tested.

4.1.1 Facilities and information required for testing

The applicant shall, when submitting equipment for type testing, provide the following facilities:

- at least one antenna connector as a test point;
- for equipment supporting diversity, or for any other reason having more than one antenna connector, the applicant shall supply coupling and/or terminating devices so that the tests can be performed via a single antenna connector;
- TETRA equipment, for example PDO radio packet modem modules which may not have an antenna connector, may be submitted for type testing by the manufacturer, or other applicant, if a suitable jig or adapter is supplied which allows the conducted tests to be carried out;
- specific test modes, as defined in subclause 5.2;
- a test connector which provides decoded data output for all uplink logical channels in the case of BS and downlink logical channels in the case of MS to be tested;
- a means to connect the equipment to the test power source according to clause 6.

The applicant shall provide the following information to the test authority:

- power class of equipment;
- receiver class A, B or Q (MS only);
- other capabilities and options implemented in equipment, including V+D or PDO, traffic channels supported;

- information related to radio sub-system of equipment, i.e. transmit and receive frequency bands, first local oscillator frequency (flo) and intermediate frequencies (if1...ifn) of receiver;
- description how to use equipment in specific test modes;
- information of power source used in equipment.

4.1.2 Choice of radio frequency channels to be tested

Unless otherwise stated, the tests described in clauses 8, 9 and 10 shall be performed on the lowest, highest and middle radio frequency channel of either the transmit or receive band of the equipment, whichever is appropriate.

4.1.3 Interpretation of the measurement results

The interpretation of the results recorded in the Test Report for the measurements described in this ETS shall be as follows:

- a) the measured value related to the corresponding limit will be used to decide whether an equipment meets the minimum requirements of the specification;
- b) the actual measurement uncertainty of the test laboratory carrying out the measurement, for each particular measurement, shall be included in the test report;
- c) the values of the actual measurement uncertainty shall be, for each measurement, equal to or lower than the figures given in clause 11. The measurement uncertainty requirements given in this specification corresponds to a confidence level of 95 %, unless otherwise stated. The confidence level is the probability that the true value of the measured parameter lies within the range of values bounded by the uncertainty.

This procedure for using maximum acceptable uncertainty values is valid until superseded by other appropriate ETSI publications covering this subject. The use of the measured value has been chosen because there is no definitive standard allowing for measurement uncertainty at the time of publication of this ETS. Therefore, the measurement uncertainty shall be used to assess the quality of the actual measurement. The measurement uncertainty values can also be used by accreditation authorities during their accreditation procedures to ensure compliance of type testing to ETSI standards.

4.2 Mechanical and electrical design

4.2.1 General

The equipment submitted for type testing by the manufacturer or other applicant, shall be designed, constructed and manufactured in accordance with sound engineering practice and with the aim to minimise harmful interference to other equipment and services.

4.2.2 Controls

Those controls which if maladjusted might increase the interfering potentialities of the equipment shall not be accessible to the user.

4.2.3 Marking

The equipment shall be marked in a visible place. This marking shall be legible, tamperproof and durable.

The marking shall include:

- the name of the manufacturer or his trade mark;
- type number of designation and serial number;
- type approval number (when allocated by appropriate authorities).

5 Radio test configuration, test signals and test modes

This clause outlines, in terms of functional blocks, the test system required to perform the radio test procedures and test modes used in clauses 8, 9 and 10.

5.1 General functional radio test configuration

The radio test system configuration shown in figure 1 is presented for information only and is not mandatory. The equipment under test shall be connected to the test system via the antenna connector. The tasks and characteristics of the test system functional blocks are described in annex B, clause B.1. All power level and frequency characteristics specified shall be, unless otherwise stated, referred to the antenna connector of the equipment under test.

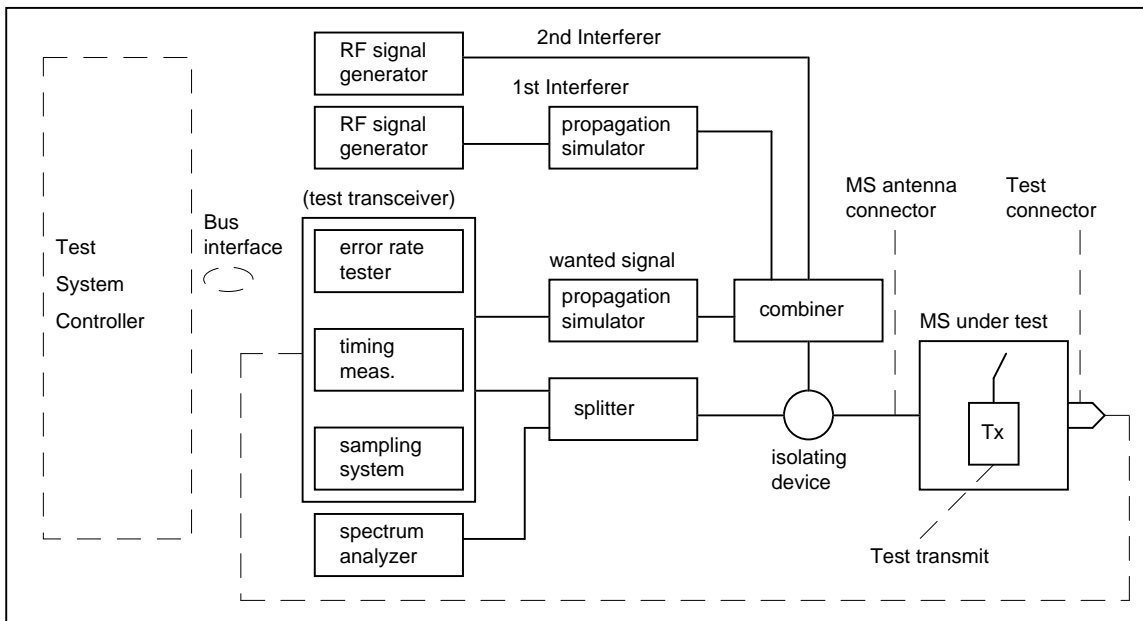

Figure 1: Radio test configuration

5.2 Radio test modes

The manufacturer shall provide the means to operate the equipment under test in either test transmit or test receive modes. The MS under test shall be instructed which test mode to operate in using the Tx_on parameter contained in the BNCH/T(V+D) or MBCH/T(PDO) channels of test signal T1 transmitted by the test system. Further details of test signal T1 and the contents of BNCH/T and MBCH/T are found in subclause 5.3.2 and annex A, clause A.3. For a BS under test the manufacturer shall provide the means to configure the BS operation for all type tests to be conducted.

5.2.1 Test receive mode

5.2.1.1 MS test receive mode

In test receive mode the MS under test shall provide at the test connector a decoded data output for each downlink logical channel (control, traffic) to be tested. The logical channel type to be decoded is indicated using the T1_burst_type parameter in the BNCH/T(V+D) or MBCH/T(PDO).

In all cases whenever the MS decodes a timeslot containing BSCH and BNCH/T(V+D) or MBCH/T(PDO) the MS shall provide the data decoded from these channels at the test connector. In the case where the MS detects an erroneous message on the BSCH, BNCH/T(V+D) or MBCH(TPDO) transmitted by the test equipment during frame 18, the MS shall remain in the same state as it was on frames 1 to 17.

5.2.1.2 BS test receive mode

Using the method provided by the manufacturer, the BS in test receive mode shall be configured to receive the desired logical channel type from the test system. The BS shall operate in its normal mode

e.g. continuous or discontinuous transmission mode and provide at the test connector the decoded data output of each uplink logical channel tested.

A V+D BS shall be configured to receive the desired logical channel on timeslot 1 of each uplink frame. During testing the test system shall use the down link BS transmissions to synchronise its uplink burst frequency and timing. The BS shall transmit in timeslot 1 of frame 18 a downlink synchronisation burst according to table 1.

Table 1: Base Station down link synchronisation burst

Burst type	Block 1	Block 2	Broadcast Block
synchronisation	BSCH	BNCH/T	AACH

The downlink synchronisation burst contains both BSCH and BNCH/T channels, which includes the T1_burst_type parameter indicating the logical channel the BS is expecting to receive. The BNCH/T is a logical channel specific to the test mode. The contents of the BSCH and BNCH/T channels used during testing are defined in annex A, clause A.3. For a V+D BS in continuous mode time slots 1 to 4 of downlink frames 1 to 17 and time slots 2 to 4 of downlink frame 18 are filled with a channel type 1 signal, see subclause 5.3.2 for details of channel types. For a V+D BS in discontinuous mode time slot 1 of downlink frames 1 to 17 are filled with a channel type 1 signal.

Unless otherwise specified the following configuration shall be used:

- channel type 1 (see subclause 5.3.2 for details);
- the parameters MS_TXPWR_MAX_CELL shall be set to 15 dBm;
- the parameter ACCESS_PARAMETER shall be set to - 53 dBm.

A PDO BS shall transmit in sub burst 1 a down link synchronisation burst according to table 2.

Table 2: Sub burst type

Sub burst type	
synchronisation	MBCH/T

The downlink synchronisation burst shall be used by the test system to synchronise its uplink sub burst frequency and timing.

The MBCH/T is a logical channel specific to the test mode. The contents of the MBCH/T used during testing are defined in annex A, clause A.3. On down link sub bursts 2 to 150 a channel type 6 signal shall be sent by the BS under test.

Unless otherwise specified the following configuration shall be used:

- channel type 6;
- start of reservation value 30 (equivalent to 240 symbol durations);
- the parameters MS_TXPWR_MAX_CELL shall be set to 15 dBm;
- the parameter ACCESS_PARAMETER shall be set to - 53 dBm.

In the case of testing a receive-only BS, the manufacturer shall also provide a BS transmitter and the required interconnections with the receive-only BS for synchronisation purposes.

5.2.2 Test transmit mode

5.2.2.1 MS V+D testing

In test transmit mode the MS under test shall transmit either a normal uplink burst or control uplink burst, as indicated by the Tx_Burst_type parameter of the BNCH/T. The MS shall be synchronised in time and frequency to the test signal T1 and shall transmit only on timeslot 1.

In test transmit mode the MS shall begin by transmitting a typical CLCH burst on subslot 1 of frame 18 followed by transmission of TCH/7,2 normal uplink bursts on frames 1 to 17 or SCH/HU control uplink burst on subslot 1 of frames 1 to 17, the sequence then repeating. Further CLCH opportunities are therefore available every multiframe. A bit stream, produced by repeating a pseudo random sequence with a length of 511 bits according to CCITT Recommendation O.153 [4], shall be used as the information to be transmitted over the logical channel. The MS shall set its transmit power according to the measured signal strength of signal T1 and the decoded power control parameters in the BNCH/T channel.

In test transmission mode the MS shall continue to monitor the BSCH and BNCH/T transmitted by the test equipment on frame 18.

5.2.2.2 MS PDO testing

In test transmit mode the MS under test shall transmit a sequence of NBCH normal uplink sub bursts. The MS transmissions shall begin with an uplink start sub burst with normal linearisation followed by an alternating sequence of uplink even and uplink odd sub bursts. The MS transmission shall be terminated using an uplink end sub burst. In test transmit mode the MS transmissions are started and stopped using the down link busy flag generated by the test system. A bit stream, produced by repeating a pseudo random sequence with a length of 511 bits according to CCITT Recommendation O.153 [4], shall be used as the information to be transmitted over the logical channel.

The MS shall set its transmit power according to the measured signal strength of signal T1 and the decoded power control parameters in the MBCH/T channel.

5.2.2.3 BS V+D & PDO testing

Using the method provided by the manufacturer, the BS in test transmit mode shall be configured to transmit the desired down link logical channel and burst/sub burst type. The BS shall operate in its normal mode e.g. continuous or discontinuous mode. For a V+D BS in discontinuous mode the BS shall transmit only in time slot 1 of each frame. A bit stream, produced by repeating a pseudo random sequence with a length of 511 bits according to CCITT Recommendation O.153 [4], shall be used as the information to be transmitted over the logical channel. The BS transmission, if required, shall begin with a BLCH burst followed by transmission of desired channel type.

5.3 Radio test signals

5.3.1 General

In principle the modulation of the test signals T1 and T2, to be described below, shall comply with ETS 300 392-2, [1], clause 5. The modulation filter is specified by a set of windowed discrete impulse response samples, $\{g'_j\}$, where $j=0\dots N-1$ and,

$$g'_j = w_j g \left(TN_s \left(\frac{j}{N-1} - \frac{1}{2} \right) \right)$$

where $g(t)$ is the symbol waveform defined in ETS 300 392-2 [1], clause 5, N_S is the number of symbols spanned by the filter and T is the symbol duration as defined in ETS 300 392-2 [1], clause 5. N_S shall be at least 15. The window coefficients, w_j , are defined by:

$$w_j = 1 - \left(\frac{j - \frac{1}{2}(N-1)}{\frac{1}{2}(N+1)} \right)^2$$

The test transmitter shall be sufficiently linear with respect to amplitude and phase (active linearisation should be avoided whenever possible) to meet the requirements in annex B, clause B.1.

5.3.2 Test signal T1 (TETRA wanted signal)

The T1 signal sequence shall comply with the TETRA (V+D or PDO) air interface multiframe, frame and slot/burst/sub burst structure and is the wanted signal transmitted by the test system during frames 1 to 17 in all receiver tests. The information transmitted by the test system in T1 frame 18 is used for test control purposes. The slot structure of T1 in frames 1 to 17 is dependant upon the type of receiver test being conducted, defined by the channel type number.

5.3.2.1 MS V+D testing

During MS V+D receiver testing, the test system shall transmit in T1 timeslot 1 down link burst and channel types according to the tables 3 and 4.

On frame 18 according to table 3.

Table 3: Test system transmission

Burst type	Block 1	Block 2	Broadcast Block
synchronisation	BSCH	BNCH/T	AACH

The BNCH/T is a logical channel specific to the test mode. The contents of the BSCH and BNCH/T to be used during the test are given in annex A, clause A.3.

On frame 1 to 17 one of the following channel types according to table 4.

Table 4: Channel types

Channel type	Burst type	Block 1	Block 2	Broadcast Block
0	normal	TCH/7,2		AACH
1	normal	TCH/7,2		AACH
2	normal	SCH/F		AACH
3	synchronisation	BSCH	SCH/HD	AACH
4	normal	TCH/2,4, N=1		AACH

A bit stream, produced by repeating a pseudo random sequence with a length of 511 bits according to CCITT Recommendation O.153 [4], shall be used as the information to be transmitted over the logical channel.

NOTE: For channel type 3, the logical channels BNCH and STCH have the same coding, interleaving format and performance specification as SCH/HD and are not, therefore, specifically tested.

Channel types 1, 2 and 4 shall be tested in continuous transmission mode only, where channel type 0 is inserted in time slots 2 to 4 of frames 1 to 18.

Channel type 3 shall be tested in discontinuous transmission mode only, where no signal is transmitted on time slots 2 to 4, except in testing class Q equipment where channel type 3 will take the form of a continuous downlink synchronisation burst.

For MS synchronisation burst acquisition performance testing, the normal multiframe structure shall not be respected and the synchronisation bursts carrying BSCH/T shall be transmitted randomly. The period between the start of two synchronisation bursts shall be randomly selected in the range between 800 and 25 000 symbol durations, with a step less than or equal to 1/4 symbol duration. Nothing shall be transmitted in the time interval between synchronisation bursts. This special discontinuous transmission mode is defined as channel type 13.

5.3.2.2 BS V+D testing

During BS V+D receiver testing the test system shall transmit in T1 timeslot 1 up link burst and channel types according to the tables 5 and 6.

On frame 18 according to table 5.

Table 5: Test system transmission

Channel type	Burst type	Sub slot 1	Sub slot 2
8	normal	SCH/F	

On frame 1 to 17 one of the following channel types according to table 6.

Table 6: Channel types

Channel type	Burst type	Sub slot 1	Sub slot 2
7	normal	TCH/7,2	
8	normal	SCH/F	
9	normal	STCH	STCH
10	normal	TCH/2,4 , N=1	
11	normal	SCH/HU	SCH/HU

In continuous BS transmission mode only, channel type 7 shall be inserted in time slots 2 to 4 of all uplink frames 1 to 18. A bit stream, produced by repeating a pseudo random sequence with a length of 511 bits according to CCITT Recommendation O.153 [4], shall be used as the information to be transmitted over the logical channel.

5.3.2.3 MS PDO testing

During MS PDO receiver testing the test system shall transmit T1 down link sub burst and channel types according to the tables 7 and 8.

On sub burst 1 according to table 7.

Table 7: Sub bursts

Channel type	Sub burst type	
5	synchronisation	MBCH/T

On sub bursts 2 to 150 according to table 8.

Table 8: Sub bursts

Channel type	Sub burst type	
6	normal	NBCH

A bit stream, produced by repeating a pseudo random sequence with a length of 511 bits according to CCITT Recommendation O.153 [4], shall be used as the information to be transmitted over the logical channel.

For MS synchronisation burst acquisition performance testing, the normal sub-burst structure shall not be respected and the synchronisation sub-bursts carrying the MBCH/T shall be transmitted randomly as described in subclause 5.3.2.1. This special discontinuous transmission mode is defined as channel type 14.

5.3.2.4 BS PDO testing

During BS PDO receiver testing the test system shall transmit T1 up link sub burst and channel types according to table 9.

On uplink sub bursts 1 to 150 according to table 9.

Table 9: Sub bursts

Channel type	Sub burst type	
12	normal	NBCH

A bit stream, produced by repeating a pseudo random sequence with a length of 511 bits according to CCITT Recommendation O.153 [4], shall be used as the information to be transmitted over the logical channel.

5.3.3 Test signal T2 (TETRA interferer)

Test signal T2 is a $\pi/4$ DQPSK modulated continuous radio signal following the structure of TETRA signals, but with all modulating bits (including training sequences) derived directly from pseudo random bit sequence (with a length of 511 bits according to CCITT Recommendation O.153 [4]).

T2 is used as an unwanted (modulated) signal.

5.3.4 Test signal T3 (unmodulated interferer)

Test signal T3 is an unmodulated continuous sinusoidal radio signal. T3 is used as an unwanted (unmodulated) signal.

6 Test conditions

6.1 General

Type tests shall be made under normal test conditions and where stated also under extreme test conditions. The test conditions and procedures shall be as specified in subclauses 6.2.1 and 6.2.2.

6.2 Power sources and ambient temperatures

During type tests the power source of the equipment shall be replaced by a test power source, capable of producing normal and extreme test voltages as specified in subclauses 6.2.1 and 6.2.2. The internal impedance of the test power source shall be low enough for its effect on the test results to be negligible. For the purpose of tests, the voltage of the power source shall be measured at the input terminals of the equipment. If the equipment is provided with a permanently connected power cable, the test voltage shall be that measured at the point of connection of the power cable to the equipment. In equipment with incorporated batteries the test power source shall be applied as close to the battery terminals as practicable. During tests the power source voltages shall be maintained within a tolerance of $\pm 1\%$ relative to the voltage at the beginning of each test.

6.2.1 Normal test conditions

The normal temperature and humidity conditions for tests shall be any convenient combination of temperature and humidity within the following ranges:

- temperature +15 C to +35 C (degrees Celsius);
- relative humidity 20 % to 75 %.

When it is impracticable to carry out the tests under the conditions stated above, the actual temperature and relative humidity during the tests shall be recorded in the Test Report.

The normal test voltage for equipment to be connected to the mains shall be the nominal mains voltage. For the purpose of these specifications, the nominal voltage shall be the declared voltage or any of the declared voltages for which the equipment was designed. The frequency of the test power source corresponding to the mains shall be between 49 Hz and 51 Hz.

When the radio equipment is intended for operation from the usual types of regulated lead-acid battery power source of vehicles, the normal test voltage shall be 1,1 times the nominal voltage of the battery (6 V, 12 V, etc.).

For operation from other power sources or types of battery (primary or secondary) the normal test voltage shall be that declared by the equipment manufacturer.

6.2.2 Extreme test conditions

For tests at extreme ambient temperatures measurements shall be made at the upper and lower temperatures of the following range:

- - 20 C to +55 C (degrees Celsius).

The extreme test voltages for equipment to be connected to an ac mains source shall be the nominal mains voltage \pm 10 %.

When the equipment is intended for operation from the usual types of regulated lead-acid battery power sources of vehicles the extreme test voltages shall be 1,3 and 0,9 times the nominal voltage of the battery (6 V, 12 V, etc.).

The extreme test voltages for equipment with power sources using non regulated batteries shall be as follows. The upper extreme test voltage shall be the normal test voltage. The lower extreme test voltage shall be:

- for the Leclanche or the lithium-type of battery, 0,85 times the nominal voltage of the battery;
- for the mercury-type or nickel cadmium type of battery, 0,9 times the nominal voltage of the battery;
- for other types of batteries, end point voltage declared by the equipment manufacturer.

However, the lower extreme test source voltages shall be those agreed between the equipment manufacturer and the testing authority for the following equipment:

- designed to use other power sources;
- capable of being operated from a variety of power sources;
- designed to include a shut-down facility to ease operation of the equipment at source voltages other than those referred to above.

The conditions shall be recorded in the Test Report and in the latter case the purpose of including this facility.

The following four extreme test condition combinations are applied while testing TETRA equipment under extreme test conditions:

- LTLV: - 20 °C and lower voltage;
- LTHV: - 20 °C and higher voltage;
- HTLV: + 55 °C and lower voltage;
- HTHV: + 55 °C and higher voltage.

Unless otherwise stated tests to be conducted under extreme test conditions shall include all the above temperature and voltage combinations.

6.3 Procedure for tests at extreme temperatures

Before measurements are made, the equipment shall have reached thermal balance in the test chamber. The equipment shall be switched off during the temperature stabilising period. In the case of equipment containing temperature stabilisation circuits designed to operate continuously, the temperature stabilisation circuits may be switched on for 15 minutes after thermal balance has been obtained, the equipment shall then meet the specified requirements. If the thermal balance is not checked by measurements, a temperature stabilising period of at least one hour, or such period as may be decided by the testing authority shall be allowed. The sequence of measurements shall be chosen, and the humidity content in the test chamber shall be controlled so that excessive condensation does not occur.

6.3.1 Equipment designed for continuous operation

Before tests at the upper temperature, the equipment shall be placed in the test chamber and left until thermal balance is attained. The equipment shall then be switched on in the transmit state for a period of 30 minutes after which the equipment shall meet the specified requirements.

Before tests at the lower temperature, the equipment shall be left in the test chamber until thermal balance is attained, then switched to the idle (non-transmit) state for a period of 4 minutes, after which the equipment shall meet the specified requirements.

6.3.2 Equipment designed for intermittent operation

Before tests at the upper temperature, the equipment shall be placed in the test chamber and left until thermal balance is attained. The equipment shall then be switched on in the idle (non-transmit) state for a period of four minutes prior to testing. In the case of transmitter CLCH testing, measurement of unwanted emissions shall take place immediately following this period. Prior to further transmitter testing the equipment shall be operated in the transmit state for a period of one minute followed by four minutes in the idle (non-transmit) state before measurements are made.

Before tests at the lower temperature, the equipment shall be left in the test chamber until thermal balance is attained, then switched to the idle (non-transmit) state for a period of one minute after which the equipment shall meet the specified requirements.

7 Technical characteristics

7.1 Transmitter parameter definitions & limits

7.1.1 Transmitter output power

7.1.1.1 Definition

Two parameters are considered here:

- a) average transmitter output power measured over the scrambled bits of a burst;
- b) transmitter output power versus time within a burst.

7.1.1.2 Limit values

The following requirements shall be met:

- a) the average transmitter output power under the normal test conditions shall be within $\pm 1,5$ dB of the nominal value specified for the BS or MS power class in ETS 300 392-2 [1], clause 6. Under extreme test conditions the average transmitter output power shall be within $+ 2,0$ dB and $- 3,0$ dB of the power value measured above;
- b) the transmitter output power versus time shall be within the power time mask specified in figure 2, measured under the normal and extreme test conditions. The time periods t1, t2 and t3 in figure 2 are defined in ETS 300 392-2 [1], clause 6.

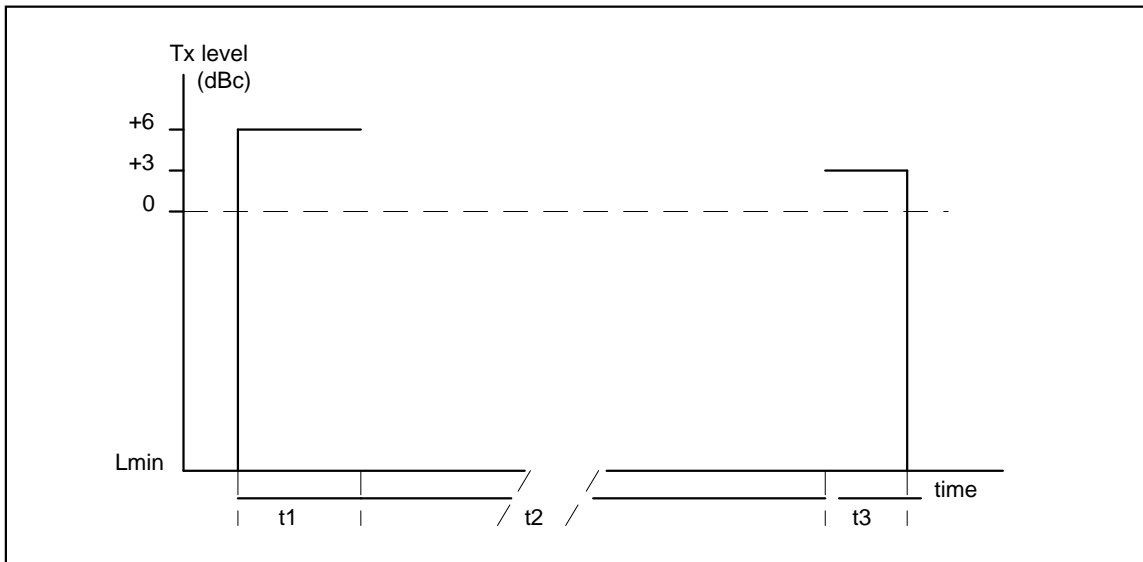

Figure 2: Power time mask of transmitted burst

For BS in discontinuous mode $L_{min} = -40$ dBc and for MS $L_{min} = -70$ dBc.

In any case, no requirement more stringent than -36 dBm applies.

7.1.2 Unwanted output power in non-active transmit state

7.1.2.1 Definition

The unwanted output power in non-active transmit state is the average power emitted by a BS operating in discontinuous mode or MS transmitter, as measured through the TETRA filter (defined in subclause 5.3.1), over a non active timeslot occurring between successive burst transmissions.

7.1.2.2 Limit values

The unwanted output power in non active transmit state shall not exceed for a BS -40 dBc or MS -70 dBc under normal test conditions. In any case, no requirement more stringent than -36 dBm applies.

NOTE: 0 dBc refers to the BS or MS transmit power.

7.1.3 Adjacent channel power due to modulation

7.1.3.1 Definition

The adjacent channel power due to modulation is the average power over the scrambled bits of a burst, as measured through the TETRA filter, emitted by an active BS or MS transmitter at the frequency offsets of ± 25 kHz, ± 50 kHz and ± 75 kHz from the nominal centre frequency of the allocated channel.

7.1.3.2 Limit values

The limit values given in table 10 shall not be exceeded at the listed frequency offsets from the nominal carrier frequency.

Table 10: Maximum adjacent channel power levels

Frequency offset	25 kHz	50 kHz	75 kHz
maximum level (normal test conditions)	- 60 dBc	- 70 dBc	- 70 dBc
maximum level (extreme test conditions)	- 50 dBc	- 60 dBc	- 60 dBc

These requirements shall be measured under normal and extreme test conditions. In any case, no requirement more stringent than - 36 dBm shall apply.

NOTE: 0 dBc refers to the BS or MS transmit power.

7.1.4 Adjacent channel power due to switching transients

7.1.4.1 Definition

The adjacent channel power due to switching transients is the peak power over the ramp-up and ramp-down periods of a burst, as measured through the TETRA filter, emitted by an active BS transmitter operating in discontinuous mode or an active MS transmitter at frequency offsets of ± 25 kHz from the nominal frequency of the allocated channel.

7.1.4.2 Limit values

The adjacent channel peak power level shall not exceed - 50 dBc. In any case, no requirement more stringent than - 36 dBm shall apply.

This requirement shall be measured under normal test conditions.

NOTE: 0 dBc refers to the BS or MS transmit power.

7.1.5 Unwanted emissions far from the carrier

7.1.5.1 Definition

The unwanted emissions are emissions (whether modulated or unmodulated) emitted by a BS or MS in the transmit state at frequencies having an offset of at least 100 kHz from the carrier frequency. The peak power level of these unwanted emissions shall be measured, in the case of conducted emissions in the frequency range from 9 kHz to 4 GHz and in the case of radiated emissions from 30 MHz to 4 GHz. The maximum allowed peak power shall be the sum of the broadband noise and discrete spurious power.

7.1.5.2 Limit values

For conducted emissions the maximum allowed peak power shall not exceed $(- 83 + 10 \log B)$ dBm, B being the measurement bandwidth in Hz. B shall be at least 100 kHz. In addition each discrete spurious emission, shall be less than - 36 dBm, measured in 30 kHz bandwidth, in the frequency range 9 kHz to 1 GHz and - 30 dBm in the range 1 GHz to 4 GHz.

These requirements shall be measured under normal test conditions.

For radiated unwanted emissions, the test given in ETS 300 113 [3] shall apply.

7.1.6 Unwanted emissions during the BLCH/CLCH (linearisation)

7.1.6.1 Definition

These unwanted emissions are emissions produced by a BS or MS, measured in a TETRA filter at a frequency offset of ± 25 kHz from the nominal carrier frequency, while the BS is transmitting a linearisation burst on the BS Linearisation Channel (BLCH) or a MS transmitting a linearisation burst on the Common Linearisation Channel (CLCH).

7.1.6.2 Limit values

The maximum allowed peak power at a frequency offset from the carrier of ± 25 kHz during the BLCH/CLCH shall not exceed -30 dBc for a maximum period of 1 ms. At all other times during the BLCH/CLCH the peak power shall not exceed -45 dBc.

NOTE: 0 dBc refers to the transmit power during normal operation after the BLCH/CLCH.

These requirements shall be measured under normal and extreme test conditions.

7.1.7 Intermodulation attenuation

7.1.7.1 Definition

Intermodulation attenuation is the ratio of the power level of the wanted signal to the power level of an intermodulation component. It is a measure of the capability of the transmitter to inhibit the generation of signals in its non-linear elements caused by the presence of the useful carrier and an interfering signal reaching the transmitter via its antenna.

7.1.7.2 Limit values

7.1.7.2.1 MS Limit values

For a MS transmitter operating at the nominal power defined by its class, the intermodulation attenuation shall be at least 60 dB for any intermodulation component when measured in 30 kHz bandwidth. The interfering signal shall be unmodulated and have a frequency offset of at least 100 kHz from the carrier frequency. The power level of the interfering signal shall be 50 dB below the level of the modulated output signal from the transmitter under test.

This requirement shall be measured under normal test conditions.

7.1.7.2.2 Limit values for single BS transmitter

In the case of base station equipment with only one transmitter, not co-located with other radio equipment operating in the same frequency band, the intermodulation attenuation shall be at least 40 dB for any intermodulation component. The interfering signal shall be unmodulated and have a frequency offset of at least 100 kHz from the carrier frequency. The power level of the interfering signal shall be 30 dB below the power level of the modulated output signal from the transmitter under test.

For all other cases, the intermodulation attenuation of the base station equipment shall be at least 70 dB for any intermodulation component. The interfering signal shall be unmodulated and have a frequency offset of at least 100 kHz from the carrier frequency. The power level of the interfering signal shall be 30 dB below the power level of the modulated output signal from the transmitter under test.

NOTE: The cases are the following:

- base station with one transmitter co-located with other radio equipment;
- base station comprising more than one transmitter, co-located or not co-located with other radio equipment.

If the intermodulation attenuation is achieved by additional, internal or external, isolating devices they shall be included in the measurements.

In any case no requirement more stringent than - 36 dBm shall apply.

All power levels stated in the cases above are referring to the antenna connector of the base station.

These requirements shall be measured under normal test conditions.

7.1.7.2.3 Limit values for Intra BS intermodulation

In a BS, intermodulation may be caused by combining several transmitters and carriers to feed a single antenna.

For all transmitters of a single TETRA base station operating at the maximum allowed power, the peak power of any intermodulation components, when measured in a 30 kHz bandwidth, shall not exceed - 60 dBc in the relevant downlink frequency band. In any case no requirement more stringent than - 36 dBm shall apply.

NOTE: The value of - 60 dBc refers to the carrier power measured at the antenna connector of the base station.

In the case where the performance is achieved by additional, internal or external isolating devices (such as circulators) they shall be supplied at the time of type testing and shall be used for measurements.

This requirement shall be measured under normal test conditions.

7.2 Receiver parameter definitions and limits

7.2.1 General

The required minimum number of samples (bits in the case of BER measurements and messages in the case of MER and PUEM measurements) and the test limit error rates used in the following receiver tests have been defined such that:

- a) the probability of passing a bad unit is lower than 0,3%;
- b) the probability of passing a good unit, operating on the limit of performance, is at least 99,5%.

A unit shall be considered bad if its true BER/MER performance is worse than 1,5 times the specified BER/MER in static conditions and worse than 1,26 times the specified BER/MER in dynamic (fading multipath) conditions. These values have been adopted (taking into account the expected shapes of the BER/MER performance) in order to not to pass an unit with a sensitivity or interference rejection performance, 1 dB worse than that of an unit which just meets the specification.

NOTE: The above definition of a bad unit does not apply to PUEM measurements.

7.2.2 Nominal error rates

7.2.2.1 Definition

The nominal error rate is a measure of the receiver performance under nominal channel conditions. Nominal channel conditions are defined as a received signal level > - 85 dBm with no interference under both static and fading conditions.

7.2.2.2 Limit values

The nominal bit error rate shall be measured using the channel type, propagation and signal level conditions detailed in the tables of annex A, clause A.2. The specified performance shall be maintained up to an input level of - 25 dBm under static conditions.

These requirements shall be measured under normal test conditions.

7.2.3 Reference sensitivity performance

7.2.3.1 Definition

The minimum required reference sensitivity performance is specified for V+D and PDO equipment according to test condition, logical channel, propagation condition, BS transmission mode and the receiver class.

7.2.3.2 Limit values

The maximum dynamic and static reference sensitivity levels for a BS receiver under normal and extreme test conditions shall not exceed the signal levels shown in table 11.

Table 11: BS receiver minimum reference sensitivity

Test condition	Dynamic ref. sensitivity	Static ref. sensitivity
normal	- 106 dBm	- 115 dBm
extreme	- 100 dBm	- 109 dBm

The maximum dynamic and static reference sensitivity levels for a MS receiver under normal and extreme test conditions shall not exceed the signal levels shown in table 12.

Table 12: MS receiver minimum reference sensitivity

Test condition	Dynamic ref. sensitivity	Static ref. sensitivity
normal	- 104 dBm	- 113 dBm
extreme	- 98 dBm	- 107 dBm

The maximum dynamic and static reference sensitivity levels for a handheld receiver under normal and extreme test conditions shall not exceed the signal levels shown in table 13.

Table 13: Handheld receiver minimum reference sensitivity

Test condition	Dynamic ref. sensitivity	Static ref. sensitivity
normal	- 103 dBm	- 112 dBm
extreme	- 97 dBm	- 106 dBm

The cases to be tested and the corresponding limit values for BER or MER are given in the tables of annex A, clause A.2. Reference sensitivity requirements shall be tested under both normal and in certain cases extreme test conditions

All MS equipment shall achieve a PUEM $<10^{-4}$ on the AACH and a PUEM $<10^{-5}$ on the BSCH, SCH/HD, SCH/HU, SCH/F, BNCH (V+D) or MBCH and NBCH (PDO), measured in dynamic conditions.

The cases to be tested, the number of required samples and the test limit values for PUEM are given in annex A, clause A.2. The PUEM tests shall be conducted under normal test conditions only.

7.2.4 Reference interference performance

7.2.4.1 Definition

The minimum required reference interference performance (for co-channel C/Ic or adjacent channel C/Ia) is specified for V+D and PDO equipment according to test condition, channel type, propagation condition and the receiver class of the equipment.

7.2.4.2 Limit values

The reference interference ratio shall be as follows:

- for co-channel interference: $C/I_c = 19$ dB;
- for adjacent channel interference: $C/I_a = -45$ dB (under normal test conditions);
 $C/I_a = -35$ dB (under extreme test conditions).

In the case of co-channel interference these specifications apply for a wanted input signal level of -85 dBm, and in the case of adjacent channel interference, for a wanted input signal 3 dB above the dynamic reference sensitivity level under appropriate test conditions. In any case the interference is a continuous TETRA random modulated signal (test signal T2) subjected to an independent realisation of the same propagation condition as the wanted signal.

The cases to be tested and the corresponding limit values for BER or MER are given in the tables of annex A, clause A.2.

These requirements shall be measured under normal and in the case of adjacent channel interference, extreme test conditions.

7.2.5 Blocking characteristics

7.2.5.1 Definition

Blocking is a measure of the capability of the receiver to receive a modulated wanted input signal in the presence of an unwanted unmodulated input signal on frequencies other than those of the spurious responses or the adjacent channels, without this unwanted input signal causing a degradation of the performance of the receiver beyond a specified limit. The blocking performance specification shall apply at all frequencies within the relevant receive band of the equipment, except those at which spurious responses occur (see subclause 7.2.6).

7.2.5.2 Limit values

The reference sensitivity performance for the TCH/7,2 for V+D or NBCH for PDO equipment, as specified in annex A, clause A.2 under static conditions, shall be met when the following signals are simultaneously input to the receiver:

- a wanted signal at frequency f_0 , 3 dB above the static reference sensitivity level as specified in subclause 7.2.3;
- a continuous sine wave signal (test signal T3) at frequency offsets of ± 1 MHz, ± 2 MHz, ± 5 MHz and ± 10 MHz from the nominal receive frequency (f_0) and at a minimum level of -25 dBm.

This requirement shall be measured under normal test conditions.

7.2.6 Spurious response rejection

7.2.6.1 Definition

Spurious response rejection is a measure of the capability of a receiver to receive a wanted modulated signal without exceeding a given degradation due to the presence of an unwanted unmodulated signal at any other frequency at which a response is obtained.

7.2.6.2 Limit values

The reference sensitivity performance for the TCH/7,2 for V+D or NBCH for PDO equipment, as specified in annex A, clause A.2 under static conditions, shall be met when the following signals are simultaneously input to the receiver:

- a wanted signal at frequency f_0 , 3 dB above the static reference sensitivity level as specified in subclause 7.2.3;

- a continuous sine wave signal (test signal T3) at frequency f , as defined below, at a level of - 45 dBm.

IN BAND: Any frequency within the relevant receive band at which the blocking specification of subclause 7.2.5 is not met. The number of such responses shall not exceed $0,05 \times$ (number of frequency channels in the relevant receive band).

OUT OF BAND: The frequencies shall be chosen according to annex A, clause A.1: "The frequencies outside the limited frequency range". These shall additionally include:

- the first image frequency $f = 2 f_{lo} - f_0$;
- the frequency $f = (f_0 + f_{lo})/2$, where f_{lo} is the frequency of the first local oscillator.

This requirement shall be measured under normal test conditions.

7.2.7 Intermodulation

7.2.7.1 Definition

Intermodulation is a measure of the capability of the receiver to receive a wanted modulated signal without exceeding a given degradation due to the presence of two or more unwanted signals with a specific frequency relationship to the wanted signal frequency.

7.2.7.2 Limit values

The reference sensitivity performance for the TCH/7,2 for V+D or NBCH for PDO equipment, as specified in annex A, clause A.2 under static conditions, shall be met when the following signals are simultaneously input to the receiver:

- a wanted signal at frequency f_0 , 3 dB above the static reference sensitivity level as specified in subclause 7.2.3;
- a continuous sine wave signal (test signal T3) at frequency f_1 and a level - 47 dBm;
- a $\pi/4$ DQPSK modulated continuous radio signal (test signal T2) at frequency f_2 , with level - 47 dBm, such that $f_0 = 2f_1 - f_2$ and $|f_2 - f_1| = 50$ kHz.

This requirement shall be measured under normal test conditions.

7.2.8 Unwanted emissions

7.2.8.1 Definition

Unwanted emissions from a MS or BS when in reception (non-transmit state) are signals at any frequency emitted by the MS or BS.

7.2.8.2 Limit values

The unwanted conducted emissions shall be less than - 57 dBm measured in frequency range from 9 kHz to 1 GHz and less than - 47 dBm in the frequency range from 1 GHz to 4 GHz, as measured in a 30 kHz bandwidth.

These requirements shall be measured under normal test conditions.

In the case of radiated unwanted emissions, the test given in ETS 300 113 [3] shall apply .

7.3 Transmitter / receiver parameter definitions & limits

7.3.1 Modulation accuracy

7.3.1.1 Definition

Modulation accuracy is defined according to ETS 300 392-2 [1], clause 6 as a difference between the actual transmitted signal waveform and the ideal signal waveform. The difference is specified in terms of vector error magnitudes at a symbol time and (half way) between the symbol times, respectively. The parameters to be measured are RMS vector error and peak vector error, as defined in ETS 300 392-2 [1], clause 6. In addition the residual carrier power of the transmitter shall be measured.

7.3.1.2 Limit values

- RMS vector error: less than 0,1 in any burst.
- Peak vector error: less than 0,3 for any symbol.
- Residual carrier power shall be less than 5 %.

These requirements shall be measured under normal test conditions.

7.3.2 Carrier frequency accuracy

7.3.2.1 Definition

Carrier frequency accuracy (error) is defined as a difference between the actual transmitted carrier frequency and its nominal value.

7.3.2.2 Limit values

The carrier frequency error in any burst shall be within $\pm 0,2$ ppm measured under normal test conditions.

7.3.3 MS receiver performance for synchronization burst acquisition

7.3.3.1 Definition

This subclause specifies reference sensitivity performance of a MS receiver for the acquisition of the synchronization (sub) burst (SB) in V+D and PDO standard. The performance is defined in terms of the probability PACQ of detecting a single transmitted SB and correctly decoding its BSCH (MBCH) information for the condition where the MS is listening on the frequency while the SB is transmitted, and where the MS is already frequency synchronised but not synchronised in terms of time slots.

7.3.3.2 Limit values

The MS receiver PACQ performance specified in table 14 shall be met with a wanted signal level at the dynamic reference sensitivity level.

Table 14: MS receiver PACQ

Receiver Class	Propagation Condition	PACQ
A	HT200	0,8
B	TU50	0,8

For test purposes, with a limited number of samples (20 synchronisation bursts) a test limit of 0,55 instead of 0,8 shall apply for both classes. This corresponds to 11 successful acquisitions. This specification applies to continuous or discontinuous downlink mode.

This requirement shall be measured under normal test conditions.

7.3.4 MS Frame alignment performance

7.3.4.1 Definition

Frame alignment performance is defined as the capability of the MS to adjust its burst transmission time with reference to the signals received from the serving BS, when the MS-BS distance is varying with time.

7.3.4.2 Limit values

The timing of each burst sent by the MS shall not differ by more than $\pm 1/4$ symbol duration (ETS 300 392-2 [1], clause 7) from the timing reference received from the BS.

This requirement shall be measured under normal test conditions.

7.3.5 MS link control

7.3.5.1 Definition

The MS shall be capable of setting its initial transmit output power based upon the received signal strength measured and the power control parameters broadcast by the serving BS on the BNCH (V+D) or MBCH (PDO).

7.3.5.2 Limit values

The MS shall use its nominal power control level that is closest to P_{MS} , where P_{MS} is defined by ETS 300 392-2 [1], clause 23:

$$- P_{MS} = \text{MIN} (\text{MS_TXPWR_MAX_CELL} , \text{ACCESS_PARAMETER} - R_{lev});$$

where:

- MS_TXPWR_MAX_CELL = maximum MS transmit power allowed in the cell;
- ACCESS_PARAMETER = parameter for access power calculation;
- R_{lev} = averaged signal level received by the MS.

All values are expressed in dBm.

NOTE: ACCESS_PARAMETER is based on the BS power and configuration and on the required mean receive power level at the BS.

The measured MS transmit power shall be within ± 8 dB of the value P_{MS} defined above, when P_{MS} is within the MS power control range.

The tolerances specified above include the contribution of the following sources of error:

- acceptable signal strength measurement uncertainty in the MS (ETS 300 392-2 [1], clause 23): ± 4 dB;
- nominal steps of 5 dB between adjacent MS power control levels: $\pm 2,5$ dB;
- acceptable uncertainty in setting the MS transmit power: $\pm 1,5$ dB.

In any case, when P_{MS} is outside the MS power control range by more than 3,5 dB the highest or lowest power control level supported by the MS shall be used accordingly. In that case the power tolerances specified in subclause 7.1.1 shall apply.

These requirements shall be measured under normal test conditions.

8 Methods of measurement for transmitter parameters

8.1 Transmitter output power

The test shall be carried out under normal and extreme (LTLV, HTHV) test conditions specified in clause 6. A test configuration as presented in subclause 5.1 should be applied. The sampling system described in annex B, subclause B.1.2 shall be employed.

8.1.1 MS transmitter output power

- a) The MS shall be connected to the test system. In the case of V+D MS testing the test system shall transmit test signal T1 continuously with channel type 1 in timeslot 1 of frames 1 to 17 and a synchronisation burst containing BSCH and BNCH/T(V+D) parameters in timeslot 1 of frame 18. In frames 1 to 18 channel type 0 shall be inserted into time slots 2 to 4. Test signal T1 level and BNCH/T parameters shall be initially set as detailed in test case 1 below and transmitted on the desired downlink frequency.

In the case of PDO MS testing the test system shall transmit test signal T1 continuously with MBCH/T in sub burst 1 followed by a NBCH (channel type 6) in sub bursts 2 to 150. Test signal T1 level and MBCH/T parameters shall be initially set as detailed in test case 1 below and transmitted on the desired downlink frequency.

All T1 levels are referenced to the antenna connector of the MS. Table 15 refers.

Table 15: T1 levels

test case	T1 level dBm	Access_parameter dBm	MS_TXPWR_MAXCELL dBm
1	- 95	- 53	40
2	- 65	- 53	20

The MS shall be set to test receive mode for a period of at least 5 seconds in which it will decode BSCH and BNCH/T(V+D) or MBCH/T(PDO) information and measure T1 signal strength. The MS shall then be set to test transmit mode.

- b) The sampling system shall capture a representation of the MS transmit burst's (excluding any CLCH transmissions) amplitude and timing (sampled at symbol rate). The procedure shall be repeated for 200 bursts and the test system shall calculate the following two parameters:
- b1) the average power versus time profile during time periods t1 and t3 (figure 2 in subclause 7.1.1), where each point represents the average power per sample, as estimated from the 200 arrays;
- b2) the average power over the scrambled bits of a burst as defined in ETS 300 392-2 [1], clause 9, ETS 300 393-2 [2], further averaged over the 200 burst measurements. This signal power value shall be used as the 0 dB reference for the power versus time profile determined in step b1) above.
- c) The steps a) and b) shall be repeated for the parameters detailed in test case 2.
- d) The test procedure above shall be performed on the lowest, highest and middle radio frequency channel in the MS transmit band.

8.1.2 BS transmitter output power

- a) The BS shall be connected to the test system and shall be set to test transmit mode. The BS shall operate in its normal mode i.e. continuous or discontinuous transmission and transmit at the BS maximum nominal output power level.

A V+D BS shall transmit in timeslot 1 of frame 18, a synchronisation burst containing BSCH and BNCH/T information. A V+D BS operating in continuous mode shall transmit a channel type 1 signal

in time slots 1 to 4 of frames 1 to 17 and time slots 2 to 4 in frame 18. A V+D BS operating in discontinuous mode shall transmit a channel type 1 signal in timeslot 1 of frames 1 to 17 only.

In the case of PDO BS a synchronisation sub burst containing MBCH/T information shall be sent on sub burst 1 and a channel type 6 signal shall be sent on sub bursts 2 to 150.

- b) The sampling system shall capture a representation of the BS transmit burst's (excluding any BLCH transmissions) amplitude and timing (sampled at symbol rate). The procedure shall be repeated for 200 bursts and the test system shall calculate the following parameters:
- b1) in the case of a discontinuous BS the average power versus time profile during time periods t_1 and t_3 (figure 2 in subclause 7.1.1), where each point represents the average power per sample, as estimated from the 200 arrays;
 - b2) the average power over the scrambled bits of a burst as defined in ETS 300 392-2 [1], clause 23, ETS 300 393-2 [2], further averaged over the 200 burst measurements. This signal power value shall be used as the 0 dB reference for the power versus time profile determined in step b1) above.
- c) If applicable steps a) and b) shall be repeated at the BS minimum nominal power level.
- d) If applicable the tests shall be performed on the lowest, highest and middle radio frequency channel in the BS transmit band.

8.2 Unwanted output power in non active transmit state

The test shall be carried out under the normal test conditions specified in clause 6.

The test method presented in subclause 8.1.1 for MS or subclause 8.1.2 for BS shall be used to measure the average unwanted transmitter output power during the non active time slots occurring between the successive burst transmissions of the MS or BS operating in discontinuous mode. The equipment under test shall transmit a burst only in one timeslot per frame and, hence each transmitted burst is followed by three non active time slots.

The test system shall calculate the average power over 200 non active time slots by applying the same measurement procedure detailed in step b2) of subclause 8.1.1 for MS and subclause 8.1.2 for discontinuous BS, to the non active time slots. The transmitter output power measured during active bursts shall be used as the 0dB reference for the unwanted output power in non active transmit state measured here.

8.3 Adjacent channel power due to modulation

The test shall be carried out under normal and extreme (LTLV, HTHV) test conditions specified in clause 6. The test method presented in subclause 8.1.1 for MS and subclause 8.1.2 for BS shall be used. The sampling system shall be set to capture the transmit power (sampled at symbol rate) appearing in the adjacent channels at the frequency offsets of ± 25 kHz, ± 50 kHz and ± 75 kHz from the nominal centre frequency of the allocated channel. The power measurements described here are timed to occur during the scrambled bits of bursts transmitted by the equipment.

For each adjacent channel, the test system shall calculate the average power over 200 bursts by applying the corresponding procedure as in step b2) of subclause 8.1.1 for MS or subclause 8.1.2 for BS. The transmitter output power obtained by using the method described in subclause 8.1 shall be used as the 0 dB reference for the adjacent channel power measured here. The test shall be conducted in the middle radio frequency channel of the equipment's transmit band and in the case of MS equipment repeated as per 8.1.1 c) and if applicable 8.1.2 c) for BS equipment.

In addition for MS equipment the test at a ± 25 kHz frequency offset shall be performed at maximum output power in the lowest and highest radio frequency channel of the MS transmit band, with a mismatch at the antenna connector such that the VSWR on the antenna feed line equals 3. The transmitter output power obtained using the method described in subclause 8.1.1 under the new mismatch condition shall be used as the 0 dB reference for the adjacent channel power measured here.

8.4 Adjacent channel power due to switching transients

The test shall be carried out under the normal test conditions specified in clause 6. The test method presented in subclause 8.1.1 for MS or subclause 8.1.2 for BS shall be used. The measurement shall be conducted only in the middle radio frequency channel of the MS or discontinuous mode BS transmit band.

The test procedure is similar to that described in subclause 8.1, except that the measurement is performed only at a frequency offset of ± 25 kHz. In this case, the sampling system shall capture a representation of the adjacent channel power (sampled at the symbol rate) during the ramp-up and ramp-down periods (t_1 , t_3) of a burst transmitted by the equipment.

For each burst the test system shall record the peak power obtained. The procedure shall be repeated for 200 bursts. The 5 bursts giving the highest peak power values shall not be taken into account. From the remaining 195 bursts the burst giving the highest peak power value shall be chosen as an estimate of the switching transient power in the adjacent channel under test.

NOTE: This procedure is used in order to avoid the test failing due to random external events which are caused by sources other than the equipment under test (e.g. spikes on the power lines). The probability that the peak power of the adjacent channel is within the measured range is of the order of 97,5 %.

8.5 Unwanted emissions far from the carrier

The test shall be carried out under normal test conditions specified in clause 6. The spectrum analyser defined in annex B, subclause B.1.3, together with the appropriate measurement filters, shall be used as a power detecting device in the frequency domain.

The test method presented in subclause 8.1.1 for MS or subclause 8.1.2 for BS shall be used. The test shall be performed in the middle radio frequency channel only.

The test system shall measure the peak power emitted by the equipment in the frequency range 9 kHz to 4 GHz, excluding the allocated channel and its adjacent channels. The measurement bandwidth and approximate video bandwidth of the spectrum analyser at different frequency offsets from the allocated channel shall be set to the values shown in table 16.

Table 16: Spectrum analyser setups

offset (MHz)	0,1 - 5	5 - 12,5	12,5 - 25,5	>25,5
meas. BW (kHz)	100	300	1 000	3 000
video BW (kHz)	300	1 000	3 000	3 000

When measuring in the frequency range below 3 MHz the measurement bandwidth shall be reduced according to specifications of the spectrum analyser.

8.6 Unwanted emissions during the BLCH/CLCH (linearisation)

The test shall be carried out under normal test and extreme (LTLV, HTHV) conditions specified in clause 6. The test shall be performed in the middle radio frequency channel only, using the test method presented in subclause 8.1.1 for MS or subclause 8.1.2 for BS. Prior to any BLCH/CLCH measurement the equipment shall operate in the non-transmit state for a period of four minutes. Once the PTT in the case of MS or the transmit on signal in the case of BS has been activated, only the transmitter emissions in the adjacent channel during the first BLCH/CLCH period shall be measured.

For the BLCH/CLCH measurement the instrument shall be centred on the frequency of either of the adjacent channels (± 25 kHz offset) to the nominal channel frequency. The adjacent channel measurement shall be made using a TETRA filter. Video triggering shall be used to capture the adjacent channel transmissions during the first BLCH/CLCH period. The video trigger level shall be set to - 30 dBm. The measurement instrument shall capture a 7,5 ms time record in order to provide the peak adjacent channel power (dBm) vs. time domain response of the signal. It is recommended that a sampling rate of at least 54 kHz is used.

The measurement instrument provides a peak adjacent channel power "dBm" reading for BLCH/CLCH period measured. To obtain a "dBc" reading the measured "dBm" value must then be subtracted from the normal average on-channel "dBm" power level, as measured in subclause 8.1 under the appropriate test conditions.

NOTE: All subsequent normal transmissions from the equipment, following this single or subsequent linearisation signals, are expected to meet the specified requirements for on-channel and adjacent channel power limits.

8.7 Intermodulation attenuation

The test shall be carried out under normal test conditions specified in clause 6. Referring to the test configuration presented in subclause 5.1, the following equipment shall be employed:

A spectrum analyser with 30 kHz measurement bandwidth as a power detecting device in frequency domain (annex B, subclause B.1.3) and an unmodulated signal generator as an interfering signal source (test signal T3, subclause 5.3.4). In addition, a directional coupler and RF attenuators shall be used to complete the measurement arrangement.

Using the procedure detailed in subclause 8.1.1 a) for MS and 8.1.2 a) for BS, the equipment under test shall be set to test transmit mode and transmit at its maximum power control level on the radio frequency channel in the middle of the transmit band. The interfering (unmodulated) signal generator shall be set to deliver the desired output power level detailed below, at a frequency of at least 100 kHz offset from the transmitter under test frequency. The frequency of signal T3 shall be chosen in such a way that the intermodulation components to be measured do not coincide with other spurious components. The spectrum analyser shall be used to measure the power of any intermodulation component occurring, in the case of a MS under test, in the TETRA uplink band or in the case of a BS under test, the TETRA downlink band.

8.7.1 MS Intermodulation attenuation

The signal generator level shall be set to deliver at the antenna connector of the transmitter under test an interfering signal (T3) at a power level 50 dB below the transmitter transmit level.

8.7.2 BS Intermodulation attenuation

The signal generator level shall be set to deliver at the antenna connector of the transmitter under test an interfering signal (T3) at a power level 30 dB below the transmitter transmit level.

8.7.3 Intra BS intermodulation

In the case of intra BS intermodulation, test signal T3 shall be switched off.

9 Methods of measurement for receiver parameters

9.1 Nominal error rates

The test shall be carried out under normal test conditions specified in clause 6. A test configuration as presented in subclause 5.1 should be applied. The equipment under test shall be connected to the test system via its antenna connector.

9.1.1 MS nominal error rate

- a) The V+D MS is set up to receive a T1 signal with channel type 1 burst in the middle radio frequency channel of the MS receive band. The propagation simulator function is set to TU50. The test system shall transmit test signal T1 such that the power level at the antenna connector of the MS is -85 dBm.
- b) At the test connector the error events in the received data shall be captured and the appropriate BER shall be calculated (refer to annex A, clause A.2).

- c) Step b) shall be repeated with a power level of - 25 dBm at the antenna connector of the MS under static channel conditions.

9.1.2 BS nominal error rate

- a) The V+D BS shall operate in its normal mode and shall transmit on timeslot 1 of frame 18 a synchronisation burst containing BNCH/T information. The BNCH/T is used to indicate which channel type the BS expects the test system to send on timeslot 1 of the corresponding uplink channel in frames 1 to 18. A BS in continuous mode shall in time slots 1 to 4 of frames 1 to 17 and time slots 2 to 4 of frame 18, send a channel type 1 signal. For a discontinuous BS a channel type 1 signal shall be sent on timeslot 1 of frames 1 to 17 only.
- b) The BS is set up to receive a T1 signal with channel type 1 burst in the middle radio frequency channel of the BS receive band. The propagation simulator function is set to TU50. The test system shall transmit test signal T1 such that the power level at the antenna connector of the BS is - 85 dBm.
- c) At the test connector the error events in the received data shall be captured and the appropriate BER shall be calculated (refer to annex A, clause A.2).
- d) Step b) shall be repeated with a power level of - 25 dBm at the antenna connector of the BS under static channel conditions.

9.2 Reference sensitivity performance

The test shall be carried out under normal and where applicable extreme (LTLV, HTHV) test conditions specified in clause 6. A test configuration as presented in subclause 5.1 should be applied. The equipment shall be connected to the test system via its antenna connector.

9.2.1 MS reference sensitivity performance

- a) Using test signal T1 the MS is set up to receive one of the logical channels defined in subclause 7.2.3. The propagation simulator function shall be set according to subclause 7.2.3. The test system shall provide the test signal T1, under normal test conditions, at a power level of - 104 dBm for mobiles or - 103 dBm for handhelds.

In order to reduce test time, only the V+D MS receiver sensitivity test using channel type 2, shall be conducted under both normal and extreme test conditions. Under extreme test conditions the test system shall provide the test signal T1, at a power level of - 98 dBm for mobiles or - 97 dBm for handhelds. Channel type 2 receiver sensitivity measurements shall also be repeated in the highest, middle and lowest channels of the receive band. In all other V+D MS test cases the receiver sensitivity test shall only be performed in the middle channel of the receive band under normal conditions.

Only PDO MS receiver sensitivity tests using channel type 6, shall be repeated under both normal and extreme test conditions in the highest, middle and lowest channels of the receive band. Under extreme test conditions the test system shall provide the test signal T1, at a power level of - 98 dBm for mobiles or - 97 dBm for handhelds. All other MS PDO receiver sensitivity testing, shall only be performed in the middle channel of the receive band under normal conditions.

- b) At the test connector the error events in the received data shall be captured and the appropriate error rate shall be calculated.
- c) Step b) shall be repeated for all test cases defined in subclause 7.2.3.

9.2.2 BS reference sensitivity performance

- a) Using the test setup outlined in 9.1.2 the BS shall be set up to receive one of the logical channels defined in 7.2.3. The test system shall provide the test signal T1 at a power level of - 106 dBm.

In order to reduce test time, only the V+D BS receiver sensitivity test using channel type 8, shall be conducted under both normal and extreme test conditions. Under extreme test conditions the test system shall provide the test signal, at a power level of - 100 dBm. Channel type 8 receiver

sensitivity measurements shall also be repeated in the highest, middle and lowest channels of the receive band. In all other V+D BS test cases the receiver sensitivity test shall only be performed in the middle channel of the receive band under normal conditions.

Only PDO BS receiver sensitivity tests using channel type 12, shall be repeated under both normal and extreme test conditions in the highest, middle and lowest channels of the receive band. Under extreme test conditions the test system shall provide the test signal, at a power level of - 100 dBm. All other BS PDO receiver sensitivity testing, shall only be performed in the middle channel of the receive band under normal conditions.

- b) At the test connector the error events in the received data shall be captured and the appropriate error rate shall be calculated.
- c) Step b) shall be repeated for all test cases defined in subclause 7.2.3.

9.2.3 PUEM performance

The PUEM performance of the receiver under test at reference sensitivity shall be measured, the test cases and conditions are detailed in the PUEM test table in annex A, clause A.2. The receiver under test shall provide along with the recovered data a message error flag at the test connector. The test system shall record those instances when an message error occurred, but the message error flag was not set. Following the completion of PUEM testing on the equipment, the test system shall generate a PUEM figure for each test case.

9.3 Reference interference performance

The tests shall be carried out under normal and in the case of adjacent channel interference, also extreme (LTLV, HTHV) test conditions specified in clause 6. A test configuration as presented in subclause 5.1 should be applied. The equipment shall be connected to the test system.

9.3.1 MS reference interference performance

- a) The MS is set up to receive one of the logical channels defined for co-channel interference in subclause 7.2.4 on a radio frequency channel in the middle of the MS receive band. The propagation simulator functions (for wanted and unwanted signals) shall be set according to subclause 7.2.4. The test system shall provide the test signal T1 (wanted signal at the nominal frequency of the MS receiver) with a power level of - 85 dBm at the antenna connector of the MS.
- b) The interfering signal source shall provide the test signal T2 (unwanted signal) at the nominal frequency of the MS receiver and with a power level of - 104 dBm at the antenna connector of the MS.
- c) At the test connector the error events in the received data shall be captured and the appropriate error rate calculated.
- d) Step c) shall be repeated for all co-channel interference test cases defined in subclause 7.2.4.
- e) The test system shall provide the wanted test signal T1 with a power level of - 101 dBm (normal test conditions) or - 95 dBm (extreme test conditions) for mobiles and - 100 dBm (normal test conditions) or - 94 dBm (extreme test conditions) for handhelds. The interfering signal source shall be set to provide the unwanted test signal T2 at the frequency offsets of ± 25 kHz from the nominal frequency of the MS receiver and with a power level of - 56 dBm (normal) or - 60 dBm (extreme) for mobiles and - 55 dBm (normal) or - 59 dBm (extreme) for handhelds.
- f) Step c) shall be repeated for all adjacent channel interference test cases defined in subclause 7.2.4.

9.3.2 BS reference interference performance

- a) Using the test setup outlined in subclause 9.1.2 the BS shall be set up to receive one of the logical channels defined for co-channel interference in subclause 7.2.4 on a radio frequency channel in the middle of the BS receive band. The propagation simulator functions (for wanted and unwanted signals) shall be set according to subclause 7.2.4. The test system shall provide the test signal T1

(wanted signal at the nominal frequency of the BS receiver) with a power level of - 85 dBm at the antenna connector of the BS.

- b) The interfering signal source shall provide the test signal T2 (unwanted signal) at the nominal frequency of the BS receiver and with a power level of - 104 dBm at the antenna connector of the BS.
- c) At the test connector the error events in the received data shall be captured and the appropriate error rate calculated.
- d) Step c) shall be repeated for all co-channel interference test cases defined in subclause 7.2.4.
- e) The test system shall provide the wanted test signal at a power level of - 103 dBm (normal test conditions) or - 97 dBm (extreme test conditions). The interfering signal source shall be set to provide the unwanted test signal T2 at the frequency offsets of ± 25 kHz from the nominal frequency of the BS receiver and with a power level of - 58 dBm (normal) or - 62 dBm (extreme).
- f) Step c) shall be repeated for all adjacent channel interference test cases defined in subclause 7.2.4.

9.4 Blocking characteristics

The test shall be carried out under normal test conditions specified in clause 6. The test configuration presented in subclause 5.1 is applied. The error rate indication scheme used in subclauses 9.2 and 9.3 may be employed. All propagation simulator functions are set to "static". The equipment shall be connected to the test system.

9.4.1 MS blocking

- a) The MS is set up to receive a T1 channel type 1 signal (i.e. TCH/7,2 (NBCH for PDO)) on a radio frequency channel in the middle of the MS receive band. The test system shall provide the wanted test signal T1 at a power level of - 110 dBm for mobiles or - 109 dBm for handhelds at the antenna connector of the MS.
- b) The interfering signal source shall provide the test signal T3 (unmodulated unwanted signal) at frequency offsets of ± 1 MHz, ± 2 MHz, ± 5 MHz and ± 10 MHz from the nominal frequency of the MS receiver at a power level of - 25 dBm. The actual values of the offset frequencies shall be adjusted such that they do not coincide with the frequencies of spurious response to be tested in subclause 9.5.1.
- c) For each of the offset frequencies chosen in step b) the bit error rate shall be indicated.

9.4.2 BS blocking

- a) Using the test setup outlined in subclause 9.1.2 the BS shall be set up to receive a T1 channel type 7 for V+D BS or a channel type 11 for PDO BS, on a radio frequency channel in the middle of the BS receive band. The test system shall provide the wanted test signal T1 at a power level of - 112 dBm at the antenna connector of the BS.
- b) The interfering signal source shall provide the test signal T3 (unmodulated unwanted signal) at frequency offsets of ± 1 MHz, ± 2 MHz, ± 5 MHz and ± 10 MHz from the nominal frequency of the BS receiver at a power level of - 25 dBm. The actual values of the offset frequencies shall be adjusted such that they don't coincide with the frequencies of spurious response to be tested in subclause 9.5.2.
- c) For each of the offset frequencies chosen in step b) the bit error rate shall be indicated.

9.5 Spurious response rejection

The test shall be carried out under the normal test conditions specified in clause 6.

The purpose of this test is to complete the procedure described in subclause 9.4 by testing the error performance of the equipment receiver when the frequency of the interfering signal is set to the predicted frequencies of spurious response, as calculated according to annex A, clause A.1 and supplemented in subclause 7.2.6.

By using the same test configuration and conditions as in subclause 9.4, except that the power level of the interfering signal shall be - 45 dBm, the error rate shall be calculated at each frequency of spurious response. Additionally, any response which exhibited an error rate exceeding the limit value in subclause 9.4 shall be tested here.

9.6 Intermodulation

The test shall be carried out under normal test conditions specified in clause 6. The test configuration presented in subclause 5.1 is applied. The error rate indication scheme used in subclauses 9.1 to 9.3 may be employed. All propagation simulator functions are set to "static". The equipment under test shall be connected to the test system.

9.6.1 MS intermodulation

- a) The MS is set up to receive a T1 channel type 1 signal (i.e. TCH/7.2 (NBCH for PDO)) on a radio frequency channel in the middle of the MS receive band. The test system shall provide the wanted test signal T1 at a power level of - 110 dBm (- 109 dBm for handhels) at the antenna connector of the MS.
- b) The (second) interfering signal source shall provide the test signal T3 (unmodulated unwanted signal) at frequency f_1 and with a power level of - 47 dBm. The (first) interfering signal source shall provide the test signal T2 (modulated unwanted signal) at frequency f_2 and with a power level of - 47 dBm, such that $f_0 = 2 f_1 - f_2$ and $f_1 - f_2 = 50$ kHz. Both unwanted power levels refer to the antenna connector of the MS.
- c) The error events in the received data shall be captured and the appropriate error rate shall be calculated.
- d) Step c) shall be repeated with the unwanted signal frequencies f_1 and f_2 set such that $f_0 = 2 f_1 - f_2$ and $f_2 - f_1 = 50$ kHz.

9.6.2 BS intermodulation

- a) Using the test setup outlined in subclause 9.1.2 the BS shall be set up to receive a T1 channel type 7 for V+D BS or a channel type 11 for PDO BS, on a radio frequency channel in the middle of the BS receive band. The test system shall provide the wanted test signal T1 at a power level of - 112 dBm at the antenna connector of the BS.
- b) The (second) interfering signal source shall provide the test signal T3 (unmodulated unwanted signal) at frequency f_1 and with a power level of - 47 dBm. The (first) interfering signal source shall provide the test signal T2 (modulated unwanted signal) at frequency f_2 and with a power level of - 47 dBm, such that $f_0 = 2 f_1 - f_2$ and $f_1 - f_2 = 50$ kHz. Both unwanted power levels refer to the antenna connector of the BS.
- c) The error events in the received data shall be captured and the appropriate error rate shall be calculated.
- d) Step c) shall be repeated with the unwanted signal frequencies f_1 and f_2 set such that $f_0 = 2 f_1 - f_2$ and $f_2 - f_1 = 50$ kHz.

9.7 Unwanted emissions

The test shall be carried out under normal test conditions specified in clause 6.

The equipment shall be connected to the test system via its antenna connector. The equipment shall be in the non-transmit state. The test system shall measure the peak power emitted by the equipment in the frequency range 9 kHz to 4 GHz. Within the transmit and receive bands the measurement bandwidth of the spectrum analyser shall be 100 kHz (video bandwidth 300 kHz). Outside the transmit and receive bands the measurement (and video) bandwidths given in subclause 8.5 shall apply. In this case, however, the frequency offsets defined shall refer to the edge of the transmit or receive band, respectively. When measuring in the frequency range below 3 MHz the measurement bandwidth shall be reduced according to the specifications of the spectrum analyser.

10 Methods of measurement for transmitter/receiver parameters

10.1 Modulation accuracy

The test shall be carried out under normal test conditions specified in clause 6. The measurements described here are performed, in the case of MS equipment on normal uplink bursts or in the case of BS equipment downlink bursts, defined in ETS 300 392-2 [1], clause 9, ETS 300 393-2 [2]. The test configuration presented in subclause 5.1 is applied. The sampling system in annex B, subclause B.1.2 shall be employed.

10.1.1 MS modulation accuracy

The MS shall be connected to the test system. The test system shall transmit test signal T1. Test signal T1 BNCH/T(V+D) or MBCH/T(PDO) parameters and level as detailed in test case 1 of subclause 8.1.1 a) shall be used. All T1 levels are referenced to the antenna connector of the MS.

The MS shall be set to test receive mode for a period of at least 5 seconds in which it will decode BSCH and BNCH/T(V+D) or MBCH/T(PDO) information and measure T1 signal strength. The MS shall then be set to test transmit mode. The modulation accuracy shall be tested by measuring the vector error magnitude as specified in subclauses 10.1.3 and 10.1.4.

10.1.2 BS modulation accuracy

The BS shall be connected to the test system. The test procedure detailed in subclause 8.1.2 a) shall be used. The modulation accuracy shall be tested by measuring the vector error magnitude as specified in subclauses 10.1.3 and 10.1.4.

10.1.3 Vector error magnitude at symbol time

- a) The sampling system shall capture a representation of the transmit burst's vector error at sampling times t_k (symbol by symbol) where t_k is the symbol time corresponding to the k -th symbol. For each symbol the sampling system shall compute the vector error $Z'(k)-S(k)$ defined in ETS 300 392-2 [1], clause 6, where $Z'(k)$ is the normalised modulation symbol transmitted by the MS and $S(k)$ is the modulation symbol which would be transmitted by an ideal MS. The sampling system shall calculate the RMS vector error RMSVE for all symbols of the burst as defined in ETS 300 392-2 [1], clause 6. The sampling system shall also calculate the peak vector error magnitude $|Z'(k)-S(k)|$ and the residual carrier power C_0 as defined in ETS 300 392-2 [1], clause 6 for each symbol of the burst and shall calculate the mean residual carrier power $\langle C_0 \rangle$ averaged over all values C_0 of the burst.
- b) The procedure described in step a) shall be repeated for 200 bursts.
- c) The procedures described in steps a) and b) shall be performed on the lowest, highest and middle radio frequency channel in the transmit band.

10.1.4 Vector error magnitude between symbol times

- a) The sampling system shall capture a representation of the transmit burst's vector error at sampling times $t_{k+1/2}$ (between all consecutive symbols) where t_k is the symbol time corresponding to the k -th symbol. For each symbol the sampling system shall compute the vector error $Z'(k+1/2)-S(k+1/2)$ defined in ETS 300 392-2 [1], clause 6, where $Z'(k+1/2)$ is the normalised modulation signal transmitted by the MS and $S(k+1/2)$ is the modulation signal which would be transmitted by an ideal MS. The sampling system shall calculate the RMS vector error RMSVE for all symbols of the burst as defined in ETS 300 392-2 [1], clause 6. The sampling system shall also calculate the peak vector

error magnitude $|Z'(k+1/2)-S(k+1/2)|$ and the residual carrier power C_0 as defined in ETS 300 392-2 [1], clause 6 for each symbol of the burst and shall calculate the mean residual carrier power $\langle C_0 \rangle$ averaged over all values C_0 of the burst.

- b) The procedure described in step a) shall be repeated for 200 bursts.
- c) The procedures described in steps a) and b) shall be performed on the lowest, highest and middle radio frequency channel in the transmit band of the equipment.

10.2 Carrier frequency accuracy

The test setup shall be according to subclause 10.1.1 in the case of MS equipment and subclause 10.1.2 in the case of BS equipment, with the following modifications:

- the test shall be carried out under normal test conditions specified in clause 6.

10.2.1 MS carrier frequency accuracy

The sampling system shall be synchronised to the internal timing reference of the test system. The MS shall adjust its frequency by means of BSCH signals received from the test system. The MS shall be connected to the test system and the test system shall transmit test signal T1. Test signal T1 level and BNCH/T(V+D) or MBCH/T(PDO) parameters as detailed in test case 1 of subclause 8.1.1 a) shall be used. All T1 levels are referenced to the antenna connector of the MS.

The MS shall be set to test receive mode for a period of at least 5 seconds in which it will decode BSCH and BNCH/T(V+D) or MBCH/T(PDO) information and measure T1 signal strength. The MS shall then be set to test transmit mode. The input level applied to the MS shall be the static reference sensitivity level.

- a) The sampling system shall capture a representation of the MS transmit burst's modulation symbol $Z(k)$ at sampling times t_k (symbol by symbol) where t_k is the symbol time corresponding to the k-th symbol. For each symbol the sampling system shall measure the phase rotation θ which is caused by the frequency difference between the MS and the sampling system, as defined in ETS 300 392-2 [1], clause 6. The sampling system shall calculate the frequency error (df) for the burst as follows:

$$df = 1/(2\pi SN_{max}) \sum_{k=1}^{SN_{max}} \theta(k)$$

where $\theta(k)$ is expressed in radians, T is the symbol duration and SNmax is the number of symbols in a burst.

- b) The procedure described in step a) shall be repeated for 20 bursts.
- c) The procedures described in steps a) and b) shall be performed on the lowest, highest and middle radio frequency channel in the MS transmit band.

10.2.2 BS carrier frequency accuracy

The BS shall be connected to the test system. The test procedure detailed in subclause 8.1.2 a) shall be used. The carrier frequency accuracy shall be tested as follows.

- a) The sampling system shall capture a representation of the BS transmit burst's modulation symbol $Z(k)$ at sampling times t_k (symbol by symbol) where t_k is the symbol time corresponding to the k-th symbol. For each symbol the sampling system shall measure the phase rotation θ which is caused by the frequency difference between the BS and the sampling system, as defined in ETS 300 392-2 [1], clause 6. The sampling system shall calculate the frequency error df for the burst as follows:

$$df = 1/(2\pi SN_{max}) \sum_{k=1}^{SN_{max}} \theta(k)$$

where $\theta(k)$ is expressed in radians, T is the symbol duration and SNmax is the number of symbols in a burst.

- b) The procedure described in step a) shall be repeated for 20 bursts.
- c) If applicable the procedures described in steps a) and b) shall be performed on the lowest, highest and middle radio frequency channel in the BS transmit band.

10.3 MS receiver performance for synchronization burst acquisition

The test shall be carried out under normal test conditions specified in clause 6. A test configuration as presented in subclause 5.1 may be applied. The propagation simulator function (wanted signal only) shall be set to TU50 for class B receiver testing and HT200 for class A receiver testing. The test system shall transmit discontinuous synchronisation bursts (channel type 13 for V+D, channel type 14 for PDO) on the middle frequency of the receive band, at a power level of - 104 dBm (mobiles) or - 103 dBm (handhelds). Before starting the synchronisation burst acquisition performance test the MS shall be switched off for a period of at least 60 seconds, following power on the MS receiver shall be fixed to the middle frequency channel of the receive band, i.e. no scanning required. The MS will now attempt to detect the synchronisation burst and decode the BSCH and BNCH/T (V+D) or MBCH/T(PDO) information. A special T1_burst_type field contained in the BNCH/T or MBCH/T, is used to place the MS into synchronisation acquisition test mode. During this period the MS may perform some frequency offset correction.

Following the first synchronisation burst which is successfully detected and decoded, the MS shall enter synchronisation acquisition test mode, this shall be immediately indicated at the test connector to inform the test system that the MS is ready for the synchronisation burst acquisition test.

Once in synchronisation acquisition mode the MS shall continuously attempt to detect a synchronisation burst and decode the BSCH and BNCH/T(V+D) or MBCH/T(PDO) information. Each successful decoding shall be indicated at the MS test connector.

The test system shall transmit 20 synchronisation bursts and count the number of successful acquisitions and calculate the PACQ.

10.4 MS Frame alignment performance

The test shall be carried out under normal test conditions specified in clause 6. A test configuration as presented in subclause 5.1 may be applied. The training sequences transmitted by the test system shall be used as a timing reference during this test procedure. The MS shall be synchronised to the test system (in terms of frequency and time slot).

The test system shall transmit test signal T1 on a frequency in the middle of the MS receive band, at the dynamic reference sensitivity level, placing the MS into test transmit mode.

- a) The propagation simulator function (T1, wanted signal only) is set to TU50 (class B) or HT200 (class A).
- b) The timing delay (TD) of bursts transmitted by the test system shall be set to zero (symbol durations).
- c) The MS shall transmit normal uplink bursts in the radio frequency channel in the middle of the MS transmit band. The timing measurement unit (refer to annex B, subclause B.1.7) shall compare the timing of the bursts received from the MS with that of the slot timing of test signal T1. The timing measurement shall be repeated for 200 bursts.
- d) The test system shall increase the delay (TD) of its transmission in steps of one symbol duration . After setting a new delay value (TD) a settling time of 10s is required for the MS before starting the next timing measurement. The step c) above shall be repeated for TD values of 1, 2 and 3 symbol durations.

10.5 MS link control

The test shall be carried out under normal test conditions specified in clause 6.

- a) The MS shall be connected to the test system. The test system shall transmit test signal T1. Test signal T1 level and BNCH/T(V+D) or MBCH/T(PDO) parameters as detailed in test case 1 in table 17 shall be used. All T1 levels are referenced to the antenna connector of the MS.

Table 17: Test Case

test case	T1 level dBm	Access_parameter dBm	MS_TXPWR_MAXCELL dBm
1	- 95	- 53	40
2	- 90	- 53	35
3	- 85	- 53	30
4	- 80	- 53	25
5	- 75	- 53	20

The MS shall be set to test receive mode for a period of at least 5 seconds in which it will decode BSCH and BNCH/T(V+D) or MBCH/T(PDO) information and measure T1 signal strength. The MS shall then be set to test transmit mode.

- b) The sampling system shall capture a representation of the MS transmit burst's (excluding any CLCH transmissions) amplitude and timing (sampled at symbol rate). The procedure shall be repeated for 200 bursts and the test system shall calculate the following two parameters:
- b1) the average power versus time profile during time periods t1 and t3 (see figure 2), where each point represents the average power per sample, as estimated from the 200 arrays;
 - b2) the average power over the scrambled bits of a burst as defined in ETS 300 392-2 [1], clause 9, ETS 300 393-2 [2], further averaged over the 200 burst measurements. This single power value shall be used as the 0 dB reference for the power versus time profile determined in step b1) above.
- c) The steps a) and b) shall be repeated for the parameters detailed in test cases 2 to 5.

The test scenario presented in figure 3 is applied. The propagation simulator function (wanted signal only) shall be set to TU50.

NOTE: The dynamic propagation condition TU50 is used in order to test implicitly the capability of the MS to perform averaged signal strength measurements under the "fading" reception conditions.

The test system shall know the maximum MS power.

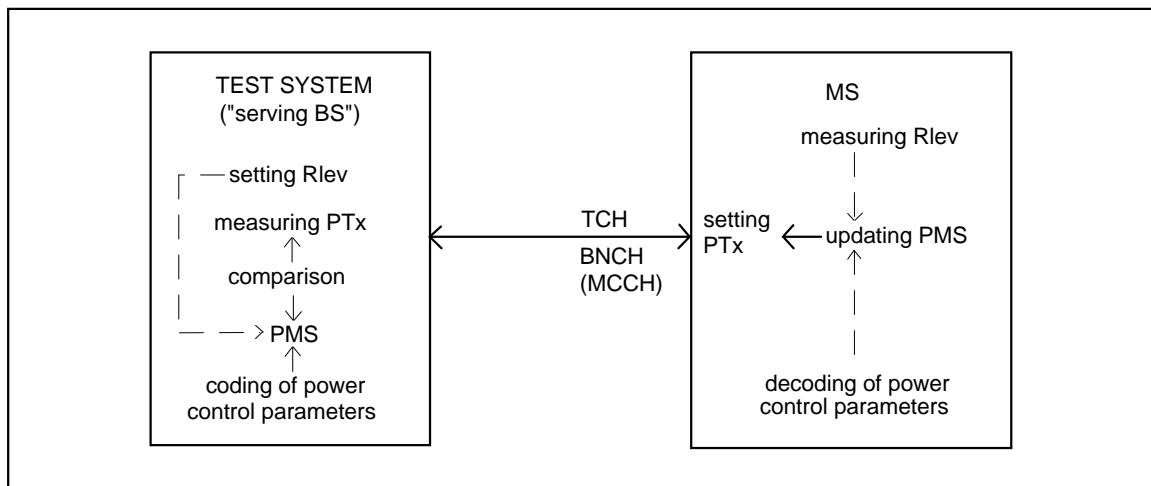

Figure 3: MS link control test scenario

11 Measurement uncertainty

Absolute measurement uncertainties: maximum values.

Valid up to 1GHz for the RF parameters unless otherwise stated.

Radio frequency	$\pm 0,02$ ppm
Average on channel RF power	$\pm 0,75$ dB
RF power versus time	± 2 dB
Adjacent channel power	± 3 dB
Unwanted power in non transmit state	± 3 dB
Unwanted emissions	± 4 dB
Intermodulation	± 3 dB
Frame alignment	$\pm 2 \times 10^{-6}$
RMS vector error	$\pm 0,01$
Peak vector error	$\pm 0,03$

Annex A (normative): TETRA receiver testing

A.1 Frequencies of spurious response

This annex provides a test method used to identify those frequencies at which the receiver under test has a response measured during the spurious response rejection test.

A.1.1 Spurious response rejection

A.1.1.1 Definition

The spurious response rejection is a measure of the capability of the receiver to receive a wanted modulated signal without exceeding a given degradation due to the presence of an unwanted modulated signal at any other frequency, at which a response is obtained.

A.1.1.2 Introduction to the method of measurement

To determine the frequencies at which spurious responses can occur the following calculations shall be made:

- a) Calculation of the "limited frequency range".

The "limited frequency range" is equal to: The frequency of the local oscillator signal (f_{lo}) applied to the 1st mixer of the receiver \pm the sum of the intermediate frequencies (if_1, \dots, if_n) and half the switching range (sr) of the receiver.

Hence, the "limited frequency range" = $f_{lo} \pm (if_1 + if_2 + \dots + if_n + sr/2)$.

- b) The calculation of the frequencies at which spurious response can occur outside the range determined in a) above is made for the remainder of the frequency range of interest.

The frequencies outside the "limited frequency range" are equal to:

- the harmonics of the frequency of the local oscillator signal (f_{lo}) applied to the 1st mixer of the receiver or the harmonics of any other oscillator used to generate reference frequencies in the receiver (fr) present at the first mixer of the receiver \pm the numeric value of the 1st intermediate frequency (if_1) of the receiver.

Hence, the frequencies of these spurious responses = $nf_{lo} + if_1$ and $pf_{fr} \pm if_1$, where n is an integer greater than or equal to 2 and p is an integer greater than or equal to 1.

The measure of the first image response of the receiver shall initially be made to verify the calculation of spurious response frequencies.

For the calculations a) and b) above, the manufacturer shall state the frequency of the receiver, the frequency of the local oscillator signal (f_{lo}) applied to the 1st mixer of the receiver, the intermediate frequencies (if_1, if_2, \dots) and the switching range (sr) of the receiver.

A.2 Test cases and test conditions for BS and MS receivers

This annex contains receiver test tables for TETRA BS and MS equipment for both V+D and PDO applications. The tables list test type and provide information on channel type used in each test, test limits, minimum sample size and signal levels. Test specifications and limits which are underscored indicate a BER measurement and those which are not, are MER measurements. For those tests measured under both normal and extreme test conditions, signal levels under extreme test conditions are shown in brackets, "()". Test tables for PUEM measurements are given at the end of the annex.

Table A.1: Test conditions for mobile/handheld receiver V+D, class A

Test type	Channel type	Logical channel	Propagation condition	Signal level (dBm)	Interferer level (dBm)	Specific BER or MER %	Test limit BER or MER %	Minimum sample size
nominal error	1	TCH/7,2	TU50	- 85/- 85		<u>0,4</u>	<u>0,448</u>	3,6E6
nominal error	1	TCH/7,2	STAT	- 25/- 25		<u>0,1</u>	<u>0,122</u>	170 000
sensitivity	2	SCH/F	TU50	- 104/- 103 (- 98/- 97)		8	8,96	6 600
sensitivity	2	AACH	TU50	- 104/- 103 (- 98/- 97)		10	11,2	6 600
sensitivity	3	BSCH	HT200	- 104/- 103		11	12,32	4 800
sensitivity	3	SCH/HD	HT200	- 104/- 103		11	12,32	4 800
sensitivity	4	AACH	HT200	- 104/- 103		17	19,04	3 000
sensitivity	4	TCH/2,4 N=1	HT200	- 104/- 103		<u>1,1</u>	<u>1,232</u>	1,29E6
co-channel interference.	2	SCH/F	HT200	- 85/- 85	104/- 104	7,5	8,4	7 000
adjacent channel interference	2	SCH/F	TU50	- 101/- 100 (- 95/- 94)	- 56/- 55 (- 60/- 59)	6,5	7,280	8 000
inter modulation	1	TCH/7,2	STAT	- 110/- 109	- 47/- 47	<u>3,5</u>	<u>4,270</u>	5 000
blocking	1	TCH/7,2	STAT	- 110/- 109	- 25/- 25	<u>3,5</u>	<u>4,270</u>	5 000
spurious response	1	TCH/7,2	STAT	- 110/- 109	- 45/- 45	<u>3,5</u>	<u>4,270</u>	5 000

Table A.2: Test conditions for mobile/handheld receiver V+D, class B

Test type	Channel type	Logical channel	Propogation condition	Signal level (dBm)	Interferer level (dBm)	Specific BER or MER %	Test limit BER or MER %	Minimum sample size
nominal error	1	TCH/7,2	TU50	- 85/- 85		<u>0,4</u>	<u>0,448</u>	3,6E6
nominal error	1	TCH/7,2	STAT	- 25/- 25		<u>0,1</u>	<u>0,122</u>	170 000
sensitivity	2	SCH/F	TU50	- 104/- 103 (- 98/- 97)		8	8,96	6 600
sensitivity	2	AACH	TU50	- 104/- 103 (- 98/- 97)		11	12,32	6 600
sensitivity	3	BSCH	TU50	- 104/- 103		8	8,96	6 600
sensitivity	3	SCH/HD	TU50	- 104/- 103		9	10,08	6 600
sensitivity	4	AACH	TU50	- 104/- 103		10	11,2	5 000
sensitivity	4	TCH/2,4 N=1	TU50	- 104/- 103		<u>0,35</u>	<u>0,392</u>	2,16E6
co-channel interference	2	SCH/F	TU50	- 85/- 85	- 104/- 104	6,5	7,280	8 500
adjacent channel interference	2	SCH/F	TU50	- 101/- 100 (- 95/- 94)	- 56/- 55 (- 60/- 59)	6,5	7,280	8 000
inter modulation	1	TCH/7,2	STAT	- 110/- 109	- 47/- 47	<u>4</u>	<u>4,880</u>	4 500
blocking	1	TCH/7,2	STAT	- 110/- 109	- 25/- 25	<u>4</u>	<u>4,880</u>	4 500
spurious response	1	TCH/7,2	STAT	- 110/- 109	- 45/- 45	<u>4</u>	<u>4,880</u>	4 500

Table A.3: Test conditions for mobile/handheld receiver V+D, class Q

Test type	Channel type	Logical channel	Propagation condition	Signal level (dBm)	Interferer level (dBm)	Specific BER or MER %	Test limit BER or MER %	Minimum sample size
nominal error	1	TCH/7,2	TU50	- 85/- 85		<u>0,4</u>	<u>0,448</u>	3,6E6
nominal error	1	TCH/7,2	STAT	- 25/- 25		<u>0,1</u>	<u>0,122</u>	170 000
sensitivity	2	SCH/F	TU50	- 104/- 103 (- 98/- 97)		8	8,96	6 600
sensitivity	2	AACH	TU50	- 104/- 103 (- 98/- 97)		10	11,2	6 600
sensitivity	3	BSCH	QS200	- 104/- 103		22	24,64	2 000
	3	SCH/HD	„	- 104/- 103		21	23,52	2 000
sensitivity	4	AACH	QS200	- 104/- 103		16	17,92	3 000
sensitivity	4	TCH/2,4 N=1	QS200	- 104/- 103		<u>0,82</u>	<u>0,918</u>	1,29E6
co-channel interference	2	SCH/F	QS200	- 85/- 85	- 104/- 104	20	22,400	3 500
adjacent channel interference	2	SCH/F	TU50	- 101/- 100 (- 95/- 94)	- 56/- 55 (- 60/- 59)	6,5	7,280	8 000
inter modulation	1	TCH/7,2	STAT	- 110/- 109	- 47/- 47	<u>3,5</u>	<u>4,270</u>	4 500
blocking	1	TCH/7,2	STAT	- 110/- 109	- 25/- 25	<u>3,5</u>	<u>4,270</u>	4 500

Table A.4: Test conditions for mobile/handheld receiver PDO, class A

Test type	Channel type	Logical channel	Propogation condition	Signal level (dBm)	Interferer level (dBm)	Specific MER %	Test limit MER %	Minimum sample size
sensitivity	6	NBCH	HT200	- 104/- 103		11	12,32	4 500
sensitivity	5	MBCH	HT200	- 104/- 103		11	12,32	4 500
sensitivity	6	NBCH	TU50	- 104/- 103 (- 98/- 97)		8	8,96	6 500
sensitivity	5	MBCH	TU50	- 104/- 103 (- 98/- 97)		8	8,96	6 500
co-channel interference	6	NBCH	TU50	- 85/- 85	- 104/- 104	7	7,84	9 000
co-channel interference	5	MBCH	TU50	- 85/- 85	- 104/- 104	6	6,720	9 000
adjacent channel interference	6	NBCH	TU50	- 101/- 100 (- 95/- 94)	- 56/- 55 (- 60/- 59)	7	7,84	9 000
inter modulation	6	NBCH	STAT	- 110/- 109	- 47/- 47	2,5	3,050	6 500
blocking	6	NBCH	STAT	- 110/- 109	- 25/- 25	2,5	3,050	6 500
spurious response	6	NBCH	STAT	- 110/- 109	- 45/- 45	2,5	3,050	6 500

Table A.5: Test conditions for mobile/handheld receiver PDO, class B

Test type	Channel type	Logical channel	Propogation condition	Signal level (dBm)	Interferer level (dBm)	Specific MER %	Test limit MER %	Minimum sample size
sensitivity	6	NBCH	TU50	- 104/- 103 (- 98/- 97)		8	8,96	6 500
sensitivity	5	MBCH	TU50	- 104/- 103		8	8,96	6 500
co-channel interference	6	NBCH	TU50	- 85/- 85	- 104/- 104	7	7,840	9 000
co-channel interference	5	MBCH	TU50	- 85/- 85	- 104/- 104	6	6,720	9 000
adjacent channel interference	6	NBCH	TU50	- 101/- 100 (- 95/- 94)	- 56/- 55 (- 60/- 59)	7	7,840	9 000
inter modulation	6	NBCH	STAT	- 110/- 109	- 47/- 47	2,5	3,050	6 500
blocking	6	NBCH	STAT	- 110/- 109	- 25/- 25	2,5	3,050	6 500
spurious response	6	NBCH	STAT	- 110/- 109	- 45/- 45	2,5	3,050	6 500

Table A.6: Test conditions for mobile/handheld receiver PDO, class Q

Test type	Channel type	Logical channel	Propogation condition	Signal level (dBm)	Interferer level (dBm)	Specific MER %	Test limit MER %	Minimum sample size
sensitivity	6	NBCH	QS200	- 104/- 103		22	24,64	2 000
sensitivity	5	MBCH	QS200	- 104/- 103		21	23,52	2 000
sensitivity	6	NBCH	TU50	- 104/- 103 (- 98/- 97)		8	8,96	6 500
sensitivity	5	MBCH	TU50	- 104/- 103		8	8,96	6 500
co-channel interference	6	NBCH	TU50	- 85/- 85	- 104/- 104	7	7,840	2 500
co-channel interference	5	MBCH	TU50	- 85/- 85	- 104/- 104	6	6,720	2 500
adjacent-channel interference	6	NBCH	TU50	- 101/- 100 (- 95/- 94)	- 56/- 55 (- 60/- 59)	7	7,840	9 000
inter modulation	6	NBCH	STAT	- 110/- 109	- 47/- 47	2,5	3,050	6 500
blocking	6	NBCH	STAT	- 110/- 109	- 25/- 25	2,5	3,050	6 500
spurious response	6	NBCH	STAT	- 110/- 109	- 45/- 45	2,5	3,050	6 500

Table A.7: Test conditions for BS V+D, class A

Test type	Channel type	Logical channel	Propogation condition	Signal level (dBm)	Interferer level (dBm)	Specific BER or MER %	Test limit BER or MER %	Minimum sample size
nominal error	7	TCH/7,2	TU50	- 85		<u>0,4</u>	<u>0,448</u>	3,6E6
nominal error	7	TCH/7,2	STAT	- 25		<u>0,1</u>	<u>0,122</u>	170 000
sensitivity	8	SCH/F	TU50	- 106 (- 100)		11	12,32	6 600
sensitivity	9	STCH	TU50	- 106 (- 100)		9	10,08	6 600
sensitivity	10	TCH/2,4 N=1	HT200	- 106 (- 100)		<u>1,3</u>	<u>1,456</u>	45 000
sensitivity	11	SCH/HU	HT200	- 106 (- 100)		9,5	10,64	5 000
co-channel interference	8	SCH/F	HT200	- 85	- 104	7,5	8,4	7 000
adjacent channel interference	8	SCH/F	TU50	- 103 (- 97)	- 58 (- 62)	6	6,72	9 000
inter modulation	7	TCH/7,2	STAT	- 112	- 47	<u>3,0</u>	<u>3,66</u>	5 800
blocking	7	TCH/7,2	STAT	- 112	- 25	<u>3,0</u>	<u>3,66</u>	5 800
spurious response	7	TCH/7,2	STAT	- 112	- 45	<u>3,0</u>	<u>3,66</u>	5 800

Table A.8: Test conditions for BS V+D, class B

Test type	Channel type	Logical channel	Propogation condition	Signal level (dBm)	Interferer level (dBm)	Specific BER or MER %	Test limit BER or MER %	Minimum sample size
nominal error	7	TCH/7,2	TU50	- 85		<u>0,4</u>	<u>0,448</u>	3.6E6
nominal error	7	TCH/7,2	STAT	- 25		<u>0,1</u>	<u>0,122</u>	170 000
sensitivity	8	SCH/F	TU50	- 106 (- 100)		8	8,96	6 600
sensitivity	9	STCH	TU50	- 106 (- 100)		8	8,96	6 600
sensitivity	10	TCH/2,4 N=1	TU50	- 106 (- 100)		<u>0,35</u>	<u>0,392</u>	160 000
sensitivity	11	SCH/HU	TU50	- 106 (- 100)		8	8,96	6 600
co-channel interference	8	SCH/F	TU50	- 85	- 104	7,5	8,4	7 000
adjacent channel interference	8	SCH/F	TU50	- 103 (- 97)	- 58 (- 62)	6	6,72	9 000
inter modulation	7	TCH/7,2	STAT	- 112	- 47	<u>4,0</u>	<u>4,88</u>	4 000
blocking	7	TCH/7,2	STAT	- 112	- 25	<u>4,0</u>	<u>4,88</u>	4 000
spurious response	7	TCH/7,2	STAT	- 112	- 45	<u>4,0</u>	<u>4,88</u>	4 000

Table A.9: Test conditions for BS receiver PDO, class A

Test type	Channel type	Logical channel	Propagation condition	Signal level (dBm)	Interferer level (dBm)	Specific MER %	Test limit MER %	Minimum sample size
sensitivity	12	NBCH	HT200	- 106		11	12,32	4 500
sensitivity	12	NBCH	TU50	- 106		9	10,08	6 600
co-channel interference.	12	NBCH	TU50	- 85	- 104	7	7,84	9 000
adjacent channel interference	12	NBCH	TU50	- 103 (- 97)	- 58 (- 62)	7	7,84	9 000
inter modulation	12	NBCH	STAT	- 112	- 47	9	10,08	6 600
blocking	12	NBCH	STAT	- 112	- 25	9	10,08	6 600
spurious response	12	NBCH	STAT	- 112	- 45	9	10,08	6 600

Table A.10: Test conditions for BS receiver PDO, class B

Test type	Channel type	Logical channel	Propogation condition	Signal level (dBm)	Interferer level (dBm)	Specific MER %	Test limit MER %	Minimum sample size
sensitivity	12	NBCH	TU50	- 106 (- 100)		8	8,96	6 600
co-channel interference	12	NBCH	TU50	- 85	- 104	7	7,84	9 000
adjacent channel interference	12	NBCH	TU50	- 103 (- 97)	- 58 (- 62)	7	7,84	9 000
inter modulation	12	NBCH	STAT	- 112	- 47	5	5,6	10 000
blocking	12	NBCH	STAT	- 112	- 25	5	5,6	10 000
spurious response	12	NBCH	STAT	- 112	- 45	5	5,6	10 000

Table A.11: PUEM Test table

Equipment type	Channel type	Logical channel	Propogation condition	Signal level (dBm)	Specific PUEM	Test limit PUEM	Max No. Errors	Sample size
MS(V+D)	2	SCH/F AACH	TU50	- 104/- 103	10^{-5} 10^{-4}	$3,5 \times 10^{-4}$ $6,5 \times 10^{-4}$	2 8	31 200
MS(PDO)	6	NBCH	TU50	- 104/- 103	10^{-5}	$3,5 \times 10^{-4}$	2	31 200
BS(V+D)	8	SCH/F	TU50	- 106	10^{-5}	$3,5 \times 10^{-4}$	2	31 200
BS(PDO)	12	NBCH	TU50	- 106	10^{-5}	$3,5 \times 10^{-4}$	2	31 200

A.3 Test signal T1, content of BSCH and BNCH/T (V+D) & MBCH/T (PDO)

The following tables define the information content of the BSCH and BNCH/T for V+D and MBCH/T for PDO bursts, used during testing.

Table A.12: Test signal T1 content of the BSCH (V+D) & MBCH/T (PDO)

Information element	Size (bits)	Values	Meaning
Colour code	6	111111	Scrambled
System code	4	0xxx 1xxx	V+D reserved PDO reserved
Timeslot number	2	00	Timeslot 1
Frame number	5	01010	Frame 18
Multiframe number	6	111100	Not used
Discontinuous TX	1	0 1	Continuous transmission Discontinuous transmission
Cell preference	2	xx	do not care
Discontinuous mode	2	xx	do not care
TS reserved frames	3	xxx	do not care
Reserved	3	xxx	do not care
TM-SDU (MLE data)	28		mobile country code, mobile network code, cell service level info set by test system

Table A.13: Test signal T1 content of the BNCH/T(V+D) & MBCH/T (PDO)

Information element	Size (bits)	Values	Meaning
PDU type	2	10	Broadcast PDU
Broadcast type	2	00	SYSINFO PDU
Main carrier	12		test signal carrier frequency
Frequency band	4		test signal carrier band
Offset	2	xx	do not care
Duplex spacing	3		
Reverse operation	1	0 1	normal (defined in ETS 300 392-2 [1], clause 23) reverse
No of common secondary control channels in use	2	00	none
MS_TXPWR_MAX_CELL	3	000 001 010 011 100 101 110 111	reserved reserved 15 dBm 20 dBm 25 dBm 30 dBm 35 dBm 40 dBm
RXLEV_ACCESS_MIN	6	000000	Defined in ETS 300 392-2 [1], clause 23
ACCESS_PARAMETER	4	0000 - 1111	- 53 dBm to - 23 dBm in 2 dB steps for subsequent power adjustments
RADIO_DOWNLINK_TIMEOUT	4	0000	Disable Radio Downlink Counter (RDC)
Tx_on	1	0 1	Reception on Transmission on
Tx_burst_type	1	0 1	Normal uplink burst Control uplink burst
T1_burst_type	4	0000 0001 0010 0011 0100 0101 0110 0111 1000 1001 1010 1011 1100 1101 1110 1111	type 0: TCH/7,2 (downlink) type 1: TCH/7,2 (downlink) type 2: SCH/F(downlink) type 3: BSCH +SCH/HD (downlink) type4: TCH/2,4 N=1 (downlink) type 5: MBCH (PDO downlink) type 6: NBCH (PDO downlink) type 7: TCH/7,2 (uplink) type 8: SCH/F (uplink) type 9: STCH + STCH (uplink) type 10: TCH/2,4 N=1 (uplink) type 11: SCH/HU + SCH/HU (uplink) type 12: NBCH (PDO uplink) type 13: random synchronisation bursts type 14: random synchronisation subbursts reserved
reserved	73		do not care

Annex B (normative): Radio test system functions

B.1 Test transmitter and receiver

B.1.1 General

The task of the test transmitter/receiver is to simulate either TETRA base station or mobile station functions required while performing the Radio Conformance Testing procedures on the TETRA equipment according to the clauses 8, 9 and 10. These tasks include:

- supporting all the logical channels defined in TETRA;
- supporting the full range of transmit and receive frequencies of TETRA according to ETS 300 392-2 [1], clause 6;
- transmitting at power levels from - 115 dBm to - 20 dBm, adjustable in steps of 0,2 dB or less, with a maximum level uncertainty of ± 1 dB and with a maximum frequency uncertainty of $\pm 0,02$ ppm;
- delaying the transmitted bursts up to 3 symbol durations in steps of one symbol duration, whenever required;
- receiving power levels with a dynamic range of at least 40 dB;
- activating and de-activating specific test modes in the MS, whenever required (optional feature).

B.1.2 Sampling system

B.1.2.1 General

The task of the sampling system, a subsystem of the test receiver, is to acquire a sampled version of a wanted TETRA modulated radio signal or an unwanted emission through a TETRA filter. The acquired complex samples (I-Q base band representation) are used for modulation accuracy and power measurements.

A sampling rate of > 4 samples per symbol duration is sufficient. The receive frequency of the sampling system shall be adjustable to the nominal equipment transmit frequencies with an uncertainty of $\pm 0,02$ ppm. Prior to sampling frequency down conversion from RF to IF and appropriate IF filtering may take place.

In order to provide credible test results the sampling system, when connected to the test transmitter, shall meet the requirements defined in the subclauses B.1.2.2 to B.1.2.4. It is assumed that the test signals T1 and T2 themselves meet the requirements given in subclauses B.1.2.2 to B.1.2.4.

B.1.2.2 Adjacent channel power measurements

The residual adjacent channel level of the test system, as measured in subclause 8.3, shall not exceed the limits shown in table B.1.1, at the listed frequency offsets from the nominal carrier frequencies, when test signal T2 is applied.

Table B.1: Maximum residual adjacent channel level of the test system

Frequency offset	Maximum level
25 kHz	- 70 dBc
50 kHz	- 80 dBc
75 kHz	- 80 dBc

B.1.2.3 Modulation accuracy measurements

The residual modulation accuracy of the test system shall meet the limit specified in subclause 7.3.1.1, when transmitting either a continuous or discontinuous test signal T1. The residual RMS vector error shall be less than 0,03 and the peak vector error shall be less than 0,1.

B.1.2.4 Measurement of unwanted output power in the nonactive transmit state

In the nonactive transmit state the output level measured as defined in subclause 7.1.2 shall not exceed the following limits:

- $L_{min} = -60$ dBc when a discontinuous test signal T1 consisting of one uplink burst per frame is applied;
- $L_{min} = -35$ dBc when a discontinuous test signal T1 consisting of one discontinuous downlink burst per frame is applied.

No extra ramping function is applied to the test signals T1 which leads to slightly increased levels compared to those specified for L_{min} in ETS 300 392-2 [1], clause 6. Nevertheless this requirement imposes an additional constraint to the TETRA filter and shall contribute to ensure its correct implementation

B.1.3 Spectrum analyzer

The spectrum analyzer is to be used as a power detecting device (in frequency domain) and is characterized as follows:

- frequency range: 9 kHz to 4 GHz;
- power level range: - 80 dBm to + 20 dBm;
- measurement uncertainty of power level: $\pm 1,5$ dB (100 kHz to 1 GHz), $\pm 3,0$ dB (1 GHz to 4 GHz);
- dynamic range: 80 dB;
- resolution bandwidths: 30 kHz, 100 kHz, 300 kHz, 1 MHz, 3 MHz;
- video bandwidths: 30 kHz, 100 kHz, 300 kHz, 1 MHz, 3 MHz;
- peak hold function selectable.

B.1.4 Error rate tester

The task of the error rate tester is to generate test bit sequences which are to be sent to the receiver under test. A Pseudo Random Bit Sequence (PRBS) with a length of 511 bits shall be used according to CCITT Recommendation O.153 [4]. The second task is to compare the bits decoded by the receiver under test with the original ones and calculate the appropriate error rates.

B.1.5 Interfering signal sources

a) First interferer:

- modulation: TETRA modulated (see test signal T2 in subclause 5.3.3);
- frequency range: nominal TETRA MS receive frequencies;
- uncertainty of frequency: $\pm 0,2$ ppm;
- power level range; - 110 dBm to - 30 dBm, adjustable in steps of 1 dB or less;
- uncertainty of power level: $\pm 1,0$ dB.

b) Second interferer:

- modulation: unmodulated sinusoidal signal (see test signal T3 in subclause 5.3.4);
- frequency range: 10 MHz to 4 GHz;
- uncertainty of frequency: $\pm 0,2$ ppm;

- power level range: - 60 dBm to 0 dBm, level adjustable in steps of 1 dB or less;

NOTE: Up to + 20 dBm in the MS transmit band; for intermodulation attenuation measurement only.

- uncertainty of power level; $\pm 1,0$ dB.

B.1.6 Propagation simulators

The task of the propagation simulators is to take into account the effect of the propagation conditions, as described in ETS 300 392-2 [1], clause 6, while testing the receiver performance.

B.1.7 Timing measurement unit

The timing measurement unit is a time interval counter within the test system. It compares the timing (training sequence) of bursts received by the test receiver with the internal timing reference of the test system. The bursts (training sequences) transmitted by the test transmitter shall be synchronized to this internal timing reference.

B.1.8 Passive test system components

The task of the passive components is to establish the appropriate interconnection of the test system and the equipment under test. The required composition and characteristics of the passive components depend on the overall implementation of the test system and are not to be defined in this specification. However, the following components may be useful herein: RF combiner, power splitter, isolating device, RF attenuators and connecting cables.

B.1.9 Test system controller

The test system controller coordinates the test system functions via an appropriate interface. It may also perform the calculations required by the test procedures and present the final test results whenever appropriate.

B.1.10 Test signal (T1, T2) requirements

B.1.10.1 Adjacent channel power

Adjacent channel power, measured in a TETRA filter, shall not exceed the limits shown in table B.1.2, at the listed frequency offsets from the nominal carrier frequencies.

Table B.2: Maximum adjacent channel power levels of the test transmitter

Frequency offset	Max. level
25 kHz	- 70 dBc
50 kHz	- 80 dbc
75 kHz	- 80 dBc

NOTE: The TETRA filter to be used for this purpose can be approximately realised by weighted integration over frequency of the adjacent channel spectrum measured with a spectrum analyzer using a narrow filter. The weighting function is the squared magnitude frequency response of the ideal TETRA filter.

B.1.10.2 Modulation accuracy

The RMS vector error and the peak vector error in any burst as defined in ETS 300 392-2 [1], clause 6 shall be less than 0,03 and 0,1, respectively. These errors shall be measured by observing the test signals T1 and T2 through a TETRA filter having the same sampled impulse response $\{g'_j\}$.

NOTE: Verification of modulation accuracy can be performed by the test transmitter itself using a built-in Cartesian loop-back facility.

Maximum acceptable measurement uncertainty:

$\pm 0,01$ for RMS and $\pm 0,03$ for peak vector error measurement.

History

Document history	
January 1995	Public Enquiry PE 78: 1995-01-30 to 1995-05-26
October 1995	Converted into Adobe Acrobat Portable Document Format (PDF)