

EUROPEAN
TELECOMMUNICATION
STANDARD

FINAL DRAFT
pr **ETS 300 392-12-6**

August 1998

Source: TETRA

Reference: DE/TETRA-03001-12-06

ICS: 33.020

Key words: TETRA, V+D

**Terrestrial Trunked Radio (TETRA);
Voice plus Data (V+D);
Part 12: Supplementary services stage 3;
Sub-part 6: Call Authorized by Dispatcher (CAD)**

ETSI

European Telecommunications Standards Institute

ETSI Secretariat

Postal address: F-06921 Sophia Antipolis CEDEX - FRANCE

Office address: 650 Route des Lucioles - Sophia Antipolis - Valbonne - FRANCE

Internet: secretariat@etsi.fr - <http://www.etsi.fr> - <http://www.etsi.org>

Tel.: +33 4 92 94 42 00 - Fax: +33 4 93 65 47 16

Copyright Notification: No part may be reproduced except as authorized by written permission. The copyright and the foregoing restriction extend to reproduction in all media.

© European Telecommunications Standards Institute 1998. All rights reserved.

Contents

Foreword.....	5
1 Scope	7
2 Normative references	7
3 Definitions and abbreviations	7
3.1 Definitions	7
3.2 Abbreviations	8
4 SS-CAD overview.....	8
4.1 Functional entities and communication routes.....	8
4.2 Protocol structure and protocol stack	8
5 SS-CAD service description	8
5.1 General	8
5.2 SS-CAD services offered over the TNSS-SAP	9
5.2.1 ACCEPT response.....	9
5.2.2 ACCEPTED indication.....	9
5.2.3 ACTIVATE indication.....	9
5.2.4 ACTIVATE request.....	10
5.2.5 CANCEL indication.....	10
5.2.6 DEACTIVATE indication.....	10
5.2.7 DEACTIVATE request.....	10
5.2.8 DEFINE indication	11
5.2.9 DEFINE request	11
5.2.10 DIVERT response	11
5.2.11 DIVERTED indication	11
5.2.12 INTERCEPTED indication	12
5.2.13 INTERROGATE indication	12
5.2.14 INTERROGATE request	12
5.2.15 REJECTED indication	12
5.2.16 REJECT response.....	13
5.2.17 REQUEST indication	13
5.3 Parameter description.....	13
6 SS-CAD protocol description.....	15
6.1 PDU descriptions	15
6.1.1 ACCEPT PDU	15
6.1.2 ACCEPTED PDU	15
6.1.3 ACTIVATE PDU	16
6.1.4 ACTIVATE ACK PDU.....	16
6.1.5 CANCEL PDU	17
6.1.6 DEACTIVATE PDU	17
6.1.7 DEACTIVATE ACK PDU	18
6.1.8 DEFINE PDU.....	19
6.1.9 DEFINE ACK PDU	19
6.1.10 DIVERT PDU.....	20
6.1.11 DIVERTED PDU.....	21
6.1.12 INTERCEPTED PDU	21
6.1.13 INTERROGATE PDU.....	21
6.1.14 INTERROGATE ACK PDU	22
6.1.15 PROFILE and PROFILE ACK information elements.....	23
6.1.16 REJECT PDU	23
6.1.17 REJECTED PDU.....	24
6.1.18 REQUEST PDU	24
6.2 Information element coding	25

6.2.1	Activation failure reason	25
6.2.2	Activation result.....	25
6.2.3	Activation type.....	26
6.2.4	Basic service restriction - called party	26
6.2.5	Basic service restriction - calling party.....	26
6.2.6	CAD PDU type element	27
6.2.7	Deactivation rejection reason	27
6.2.8	Deactivation result	27
6.2.9	Definition failure reason	28
6.2.10	Definition result	28
6.2.11	Dispatcher address type	28
6.2.12	Interception cause	29
6.2.13	Interception type	29
6.2.14	Interrogation failure reason.....	29
6.2.15	Interrogation result.....	29
6.2.16	Multiple user mask.....	29
6.2.17	Range type.....	29
6.2.18	Rejection cause	29
6.2.19	Restricted basic service.....	30
6.2.20	Restricted destination address type.....	30
6.2.21	Restricted destination external subscriber number	30
6.2.22	Restricted parties.....	30
6.2.23	Restricted source address type	30
6.2.24	Restricted user address type	30
6.2.25	Type of restriction change	31
6.3	SS-CAD protocol states	31
6.4	Protocol states for FE1.....	32
6.4.1	Protocol states for FE2	34
6.4.2	Protocol states for FE3	38
6.4.3	Protocol states for FE7	40
6.5	Procedures.....	42
6.5.1	General routing of SS information	42
6.5.2	Procedures for FE1.....	42
6.5.3	Procedures for FE2.....	43
6.5.3.1	CAD invocation procedures	43
6.5.3.2	Call authorization.....	43
6.5.3.3	Activation/deactivation procedures	44
6.5.3.4	Definition procedure.....	44
6.5.3.5	Interrogation procedure.....	45
6.5.4	Procedures for FE3.....	45
6.5.5	Procedures for FE7.....	45
6.5.5.1	Normal operation of FE7	45
6.5.5.2	Calling user A disconnects during interception	45
6.5.5.3	Activation/deactivation/definition/interrogation requests from the dispatcher	45
	History	46

Foreword

This final draft European Telecommunication Standard (ETS) has been produced by the Terrestrial Trunked Radio (TETRA) Project of the European Telecommunications Standards Institute (ETSI), and is now submitted for the Voting phase of the ETSI standards approval procedure.

This ETS is a multi-part standard and will consist of the following parts:

- Part 1: "General network design".
- Part 2: "Air Interface (AI)".
- Part 3: "Inter-System Inter-working (ISI)".
- Part 4: "Gateways".
- Part 5: "Peripheral Equipment Interface (PEI)".
- Part 6: "Line connected Station (LS)", (DE/TETRA-03001-6).
- Part 7: "Security".
- Part 9: "General requirements for supplementary services".
- Part 10: "Supplementary services stage 1".
- Part 11: "Supplementary services stage 2".
- Part 12: "Supplementary services stage 3".**
- Part 13: "SDL model of the Air Interface (AI)".
- Part 14: "Protocol Implementation Conformance Statement (PICS) proforma specification".

Proposed transposition dates	
Date of latest announcement of this ETS (doa):	3 months after ETSI publication
Date of latest publication of new National Standard or endorsement of this ETS (dop/e):	6 months after doa
Date of withdrawal of any conflicting National Standard (dow):	6 months after doa

Blank page

1 Scope

This ETS defines the stage 3 specifications of the Supplementary Service Call Authorized by Dispatcher (SS-CAD) for the Terrestrial Trunked RAdio (TETRA) as provided by European operators. Stage 3 defines the signalling system protocols needed to implement the service described in stage 1 and stage 2. The stage 1 and stage 2 aspects are detailed in ETS 300 392 10-6 [2] and ETS 300 392-11-6 [3] respectively. Aspects relating to all supplementary services are detailed in ETS 300 392-9 [6].

Charging principles and the Man-Machine Interface (MMI) are outside the scope of this ETS.

The SS-CAD ensures that predefined TETRA calls do not proceed without first being authorized by a dispatcher.

2 Normative references

This ETS incorporates, by dated or undated reference, provisions from other publications. These normative references are cited at the appropriate places in the text and the publications are listed hereafter. For dated references, subsequent amendments to, or revisions of, any of these publications apply to this ETS only when incorporated in it by amendment or revision. For undated references the latest edition of the publication referred to applies.

- [1] ITU-T Recommendation Z.100 (1993): "Specification and Description Language (SDL)".
- [2] ETS 300 392-10-6: "Terrestrial Trunked Radio (TETRA); Voice plus Data (V+D); Part 10: Supplementary services stage 1; Part 10-06: Call authorized by dispatcher".
- [3] ETS 300 392-11-06: "Terrestrial Trunked Radio (TETRA); Voice plus Data (V+D); Part 11: Supplementary services stage 2; Part 11-06: Call Authorized by Dispatcher (CAD)".
- [4] ETS 300 392-1: "Terrestrial Trunked Radio (TETRA); Voice plus Data (V+D); Part 1: General network design".
- [5] ETS 300 392-2: "Terrestrial Trunked Radio (TETRA); Voice plus Data (V+D); Part 2: Air Interface (AI)".
- [6] ETS 300 392-9: "Terrestrial Trunked Radio (TETRA); Voice plus Data (V+D); Part 9; General Supplementary Services Design".
- [7] ETS 300 392-3-2: "Terrestrial Trunked Radio (TETRA); Voice plus Data (V+D); Part 3; Interworking - Basic Operation (ISI); Subpart 2: ISI Individual Call (ANF-ISIIC); Stage 1, 2 and 3 Descriptions".

3 Definitions and abbreviations

3.1 Definitions

For the purposes of this ETS, the following definitions apply:

authorized user: The user who can make service definition. The authorized user can also activate/deactivate and interrogate the service.

dispatcher: The user to whom the request for authorization shall be directed to. This user is also able to activate/deactivate SS-CAD for other users (individuals and groups) within his responsibility area and interrogate the activation status for these users.

restricted user: The user who's calls are forced to be authorized by a dispatcher before the call can proceed. The restricted user can be either the calling user (A) or the called user (B) or both.

3.2 Abbreviations

For the purposes of this ETS, the following abbreviations apply:

CAD	Call Authorized by Dispatcher
CC	Call Control
CMCE	Circuit Mode Control Entity
FE	Functional Entity
GTSI	Group TETRA Subscriber Identity
ISI	Inter-System Interface
ITSI	Individual TETRA Subscriber Identity
LS	Line Station
MMI	Man Machine Interface
MS	Mobile Station
PDU	Protocol Data Unit
SAP	Service Access Point
SDL	Specification and Description Language
SNA	Short Number Address
SS	Supplementary Service

NOTE: The abbreviation SS is only used when referring to a specific supplementary service.

SSI	Short Subscriber Identity
SwMI	Switching and Management Infrastructure
TETRA	Terrestrial Trunked RAdio
V+D	Voice plus Data

4 SS-CAD overview

4.1 Functional entities and communication routes

The functional model for SS-CAD consists of Functional Entities FE1 to FE5 as defined in ETS 300 392-11-06 [3], subclause 4.1.

These functional entities can, for one call, be located in different TETRA systems, refer to ETS 300 392-11-06 [3], subclause 4.

4.2 Protocol structure and protocol stack

SS-CAD PDUs shall be routed as specified in ETS 300 392-9 (e.g. at the air interface in facility information elements for the call related SS-CAD PDUs and in U/D-FACILITY PDUs for the call unrelated SS-CAD PDUs, and using ANF-ISISS for conveying SS-CAD PDUs over the ISI). In addition some specific SS-CAD information elements have been included in the definition of some ANF-ISIIC and ANF-ISIGC PDUs. This ETS is normative for the protocol architecture and user application Service Access Points (SAPs) within the MS/LS, but gives an informative description of the protocol within the SwMI.

5 SS-CAD service description

5.1 General

This clause describes the CAD specific services offered by the Circuit Mode Control Entity (CMCE) at the Supplementary Services Service Access Point (TNSS-SAP) of the TETRA Voice plus Data (V+D) layer 3 service boundary. The SS-CAD service access point may be used in conformance testing as a normative boundary in TETRA Mobile Stations (MSs) and TETRA Line Stations (LSs).

NOTE 1: As this ETS only deals with the SS-CAD all service primitives has been shown without a TNSS-CAD-prefix e.g. TNSS-CAD-ACTIVATE request is shortened to ACTIVATE request.

NOTE 2: User application is the user of the supplementary service.

5.2 SS-CAD services offered over the TNSS-SAP

The SS-CAD service primitives at the restricted user MS/LS (FE1) TNSS-SAP shall be:

- a) ACCEPTED indication;
- b) DIVERTED indication;
- c) REJECTED indication;
- d) INTERCEPTED indication.

The SS-CAD service primitives specific at the authorized user MS/LS (FE3) TNSS-SAP shall be:

- a) DEFINE request;
- b) DEFINE indication;

The SS-CAD service primitives at the authorized user MS/LS (FE3) and dispatcher (FE7) TNSS-SAP shall be:

- a) ACTIVATE request;
- b) ACTIVATE indication;
- c) DEACTIVATE request;
- d) DEACTIVATE indication;
- e) INTERROGATE request;
- f) INTERROGATE indication.

The SS-CAD service primitives specific at the dispatcher (FE7) TNSS-SAP shall be:

- a) ACCEPT response
- b) CANCEL indication
- c) DIVERT response
- d) REJECT response
- e) REQUEST indication

NOTE: Following service primitives assume that a call identifier or equivalent information is exchanged implicitly or explicitly with the primitive, when the primitive is related to a call.

5.2.1 ACCEPT response

The user application shall offer an ACCEPT response to the dispatching user MS/LS (FE7) to indicate that the call has been authorized. The only parameter for this primitive is an optional Access priority.

5.2.2 ACCEPTED indication

The calling user MS/LS (FE1) shall offer an ACCEPTED indication to the user application to inform that the call authorization is successfully completed. There are no parameters for this primitive.

5.2.3 ACTIVATE indication

The authorized or dispatching user MS/LS (FE3 or FE7) shall offer an ACTIVATE indication to the user application to inform an activation of call authorization.

Parameters for the primitive ACTIVATE indication shall be as defined in table 1.

Table 1: Parameters for the primitive ACTIVATE indication

Parameter	Indication
Activation result	M
Restricted user TETRA identity (ies)	M (note)
NOTE: It is optional to support more than one identities.	

5.2.4 ACTIVATE request

The user application shall offer an ACTIVATE request to the authorized or dispatching user MS/LS (FE3 or FE7) to request an activation of call authorization.

Parameters for the primitive ACTIVATE request shall be as defined in table 2.

Table 2: Parameters for the primitive ACTIVATE request

Parameter	Request
Access priority	O
Restricted user TETRA identity (ies)	M (note)
Intercepting dispatcher identity (ies)	O
NOTE: It is optional to support more than one identities.	

5.2.5 CANCEL indication

The dispatching user MS/LS (FE7) shall offer a CANCEL indication to the user application to indicate that the restricted user no longer expects a call authorization. There are no parameters for this primitive.

5.2.6 DEACTIVATE indication

The authorized or dispatching user MS/LS (FE3 or FE7) shall offer a DEACTIVATE indication to the user application to inform a deactivation of call authorization.

Parameters for the primitive DEACTIVATE indication shall be as defined in table 3.

Table 3: Parameters for the primitive DEACTIVATE indication

Parameter	Indication
Deactivation result	M
Restricted user TETRA identity (ies)	M (note)
NOTE: It is optional to support more than one identities.	

5.2.7 DEACTIVATE request

The user application shall offer a DEACTIVATE request to the authorized or dispatching user MS/LS (FE3 or FE7) to request a deactivation of call authorization.

Parameters for the primitive DEACTIVATE request shall be as defined in table 4.

Table 4: Parameters for the primitive DEACTIVATE request

Parameter	Request
Access priority	O
Restricted user TETRA identity	M (note)
NOTE: It is optional to support more than one identities.	

5.2.8 DEFINE indication

The authorized user MS/LS (FE3) shall offer a DEFINE indication to the user application to indicate a result of the call authorization definition request.

Parameters for the primitive DEFINE indication shall be as defined in table 5.

Table 5: Parameters for the primitive DEFINE indication

Parameter	Indication
Definition result	M
Restricted user TETRA identity	M (note)
NOTE: It is optional to support more than one identities.	

5.2.9 DEFINE request

The user application shall offer DEFINE request to the authorized user MS/LS (FE3) to make a call authorization definition.

Parameters for the primitive DEFINE request shall be as defined in table 6.

Table 6: Parameters for the primitive DEFINE request

Parameter	Request
Access priority	O
Activate/deactivate	M
Restricted user TETRA identity	M (note 1)
Intercepting dispatcher identity	O (note 2)
Restricted basic service incoming	O
Restricted basic service outgoing	O
Restricted source address	O (note 2)
Restricted destination address	O (note 2)
Restricted area (note 2)	O (note 2)
NOTE 1: It is optional to support more than one identities.	
NOTE 2: Repeatable.	

5.2.10 DIVERT response

The user application shall offer DIVERT response to the dispatching user MS/LS (FE7) to indicate that the call shall be diverted to the authorized user. The only parameter for this primitive is an optional Access priority.

5.2.11 DIVERTED indication

The calling user MS/LS (FE1) shall offer a DIVERTED indication primitive to the user application to inform that the call is diverted to the dispatcher for authorization.

Parameters for the primitive DIVERTED indication shall be as defined in table 7.

Table 7: Parameters for the primitive DIVERTED

Parameter	Indication
Interception cause	M
Intercepting dispatcher identity	O

5.2.12 INTERCEPTED indication

The calling user MS/LS (FE1) shall offer an INTERCEPTED indication primitive to the user application to inform that the call authorization has started.

Parameters for the primitive INTERCEPTED indication shall be as defined in table 8.

Table 8: Parameters for the primitive INTERCEPTED indication

Parameter	Indication
Interception cause	M
Intercepting dispatcher identity	O

5.2.13 INTERROGATE indication

The authorized or dispatching user MS/LS (FE3 or FE7) shall offer an INTERROGATE indication to the user application to provide an interrogation result of call authorization.

Parameters for the primitive INTERROGATE indication shall be as defined in table 9.

Table 9: Parameters for the primitive INTERROGATE indication

Parameter	Indication
Restricted user TETRA identity	M
Intercepting dispatcher identity	M
Interrogation result	M
Restricted basic service incoming	O
Restricted basic service outgoing	O
Restricted source address	O (note)
Restricted destination address	O (note)
Restricted area	O (note)
NOTE:	Repeatable.

5.2.14 INTERROGATE request

The user application shall offer an INTERROGATE request to the authorized or dispatching user MS/LS (FE3 or FE7) to request an interrogation of call authorization.

Parameters for the primitive INTERROGATE request shall be as defined in table 10.

Table 10: Parameters for the primitive INTERROGATE request

Parameter	Request
Access priority	O
Restricted user TETRA identity	M

5.2.15 REJECTED indication

The calling user MS/LS (FE1) shall offer a REJECTED indication primitive to the user application to inform that the call authorization has failed.

Parameters for the primitive REJECTED indication shall be as defined in table 11.

Table 11: Parameters for the primitive REJECTED indication

Parameter	Indication
Rejection cause	M
Intercepting dispatcher identity	O

5.2.16 REJECT response

The user application shall offer a REJECT response to the dispatching user MS/LS (FE7) to indicate that the call has not been authorized and shall be disconnected.

Parameters for the primitive REJECT response shall be as defined in table 12.

Table 12: Parameters for the primitive REJECT response

Parameter	Request
Access priority	O
Rejection cause	M

5.2.17 REQUEST indication

The dispatching user MS/LS (FE7) shall offer a REQUEST indication to the user application to indicate a need for a call authorization.

Parameters for the primitive REQUEST indication shall be as defined in table 13.

Table 13: Parameters for the primitive REQUEST indication

Parameter	Indication
Interception cause	M
Calling user's number	O
Called user's number	O
Restricted area - calling user	O
Restricted area - called user	O
Restricted basic service incoming	O
Restricted basic service outgoing	O

5.3 Parameter description

Access priority =

- Low;
- High;
- Emergency.

NOTE: The emergency priority should not be used in the procedures "definition", "interrogation" or "normal operation".

Activate/deactivate =

- Activate;
- Deactivate.

Activation result =

- Not activated;
- Activated;
- Not authorized restricted user;
- Not valid restricted user;
- Not authorized dispatcher;
- Not valid dispatcher;
- No dispatchers available;
- PDU contents invalid.

Deactivation result =

See Activation result.

Definition result =

- Defined;
- Rejected for undefined reason;
- Not authorized source/destination/dispatcher identity;
- Invalid source/destination/dispatcher identity;
- Invalid area;
- Not authorized basic service;
- PDU contents invalid.

Intercepting dispatcher identity =

See ETS 300 392-1 [5] cause 7.

Interception cause =

- Not defined;
- Restricted basic service;
- Restricted destination address;
- Restricted source address;
- Restricted area.

Interception type =

- Immediate set-up;
- Dispatcher requested set-up.

Interrogation result =

See Activation result.

Rejection cause =

- Reason not defined;
- Restricted basic service;
- Restricted destination address;
- Restricted source address;
- Area rejection.

Restricted area =

See ETS 300 392-2 [5], subclause 14.8.1.

Restricted basic service incoming/outgoing =

No restrictions;
Speech service;
Data service;
Speech and data service.

Restricted user TETRA identity =

See ETS 300 392-1 [5] cause 7.

6 SS-CAD protocol description

6.1 PDU descriptions

ETS 300 392-9 specifies the coding:

- of the facility information element which is used to convey call related SS-CAD PDUs at the air and line station interfaces;
- of the D-FACILITY or U-FACILITY PDU which are used to convey call-unrelated SS-CAD PDUs at the air and line station interfaces; and
- of the ANF-ISISS Invoke APDU which is used to convey SS-CAD PDUs over the ISI.

The general rules specified in ETS 300 392-2 [5], subclause 14.7 for information elements in PDUs apply for SS-CAD PDUs. These PDUs are specified in the following subclauses.

6.1.1 ACCEPT PDU

ACCEPT PDU is offered from FE7 to FE2. The ACCEPT PDU shall contain information elements as defined in table 14.

Table 14: Facility element coding for ACCEPT PDU

Information element	Length	Type	C/O/M	Remark
SS type	6	1	M	Defined in ETS 300 392-9 [6],
CAD PDU type	5	1	M	ACCEPT
SS-CAD intercepting SwMI call identifier	14	1	M	note 1 and note 2
NOTE 1: Shall be as defined in ETS 300 392-2 [5], subclause 14.8.				
NOTE 2: When ACCEPT PDU is call related, this information element is redundant.				

6.1.2 ACCEPTED PDU

ACCEPTED PDU is offered from FE2 to FE1. The ACCEPTED PDU shall contain information elements as defined in table 15.

Table 15: Facility element coding for ACCEPTED PDU

Information element	Length	Type	C/O/M	Remark
SS type	6	1	M	Defined in ETS 300 392-9 [6]
CAD PDU type	5	1	M	ACCEPTED

6.1.3 ACTIVATE PDU

ACTIVATE PDU is offered from FE3 or FE7 to FE2. The ACTIVATE PDU shall contain information elements as defined in table 16.

Table 16: Facility element coding for ACTIVATE PDU

Information element	Length	Type	C/O/M	Remark
SS type	6	1	M	Defined in ETS 300 392-9 [6]
CAD PDU type	5	1	M	ACTIVATE
Range type for restricted user/users	4	1	M	
Restricted user address type	2	1	M	note 1
Restricted user SSI	24	1	C	note 2, note 3
Restricted user extension	24	1	C	note 2, note 3
Range type for dispatcher/dispatchers	4	2	O	note 4, note 5
Dispatcher address type	2	2	C	note 6, note 7
Dispatcher SSI	24	2	C	note 3, note 7
Dispatcher extension	24	2	C	note 3, note 7
NOTE 1:	Shall be repeated as defined by the Range type for the restricted user/users element. This PDU shall contain at least one Restricted user.			
NOTE 2:	Shall be as defined by the Restricted user address type element.			
NOTE 3:	Defined in ETS 300 392-2 [5], subclauses 14.7 and 14.8.			
NOTE 4:	If the Range type for dispatcher/dispatchers element indicates that no Dispatcher address follows, then it shall be assumed that the activation is against all dispatchers defined in subscription.			
NOTE 5:	The dispatcher/dispatchers shall be valid for all the previous restricted users.			
NOTE 6:	Shall be repeated as defined by the information element range type for dispatcher / dispatchers.			
NOTE 7:	Shall be as defined by the Dispatcher type identifier.			

6.1.4 ACTIVATE ACK PDU

ACTIVATE ACK PDU is offered from FE2 to FE3 or FE7. Each restricted user address in the ACTIVATE PDU which was not accepted and not activated will be sent back in the ACTIVATE ACK. The ACTIVATE ACK PDU shall contain information elements as defined in table 17.

When activation result information element values are different for different restricted users then FE2 will send multiple ACTIVATE ACK PDUs one for each different activation result. The multiple user mask shall be according to the range used in that ACTIVATION ACK PDU and it may be different than the range in the corresponding ACTIVATE PDU.

When the Activation result information element indicates "Accepted", then each "1" bit in the Multiple user mask information element shall indicate users who's SS-CAD restrictions are activated.

When the Activation result information element indicates "Not accepted", then each "1" bit in the Multiple user mask information element shall indicate users against which activation of the SS-CAD restrictions are failed. The SS-CAD restrictions state of those users can be either "activated" or "deactivated" and the actual state is not indicated in the ACTIVATE ACK PDU.

Table 17: Facility element coding for ACTIVATE ACK PDU

Information element	Length	Type	C/O/M	Remark
SS type	6	1	M	Defined in ETS 300 392-9 [6]
CAD PDU type	5	1	M	ACTIVATE ACK
Range type for restricted user	4	1	M	
Restricted user address type	2	1	M	note 1
Restricted user SSI	24	1	C	note 2; note 3
Restricted user extension	24	1	C	note 2; note 3
Multiple user mask present	1	1	M	
Multiple user mask	Variable	1	C	note 4
Activation result	1	1	M	note 5
Activation failure reason	7	1	C	note 6
NOTE 1:	Shall be repeated as defined by the Range type for the restricted user element.			
NOTE 2:	Shall be as defined by the Restricted user address type element.			
NOTE 3:	Defined in ETS 300 392-2 [5], subclauses 14.7 and 14.8.			
NOTE 4:	This information element shall be present only when the Multiple user mask present information element indicates "Present". This information element shall be used, when the activation result information element is valid only against a subset of the restricted users. The length of the information element shall be equal to the number of users in the range for restricted users.			
NOTE 5:	This information element shall indicate activation result against those restricted users indicated in the Multiple user mask information element or all users in the range when the Multiple user mask information element is omitted.			
NOTE 6:	This information element shall be present only when the Activation result is "Not accepted".			

6.1.5 CANCEL PDU

CANCEL PDU is offered from FE2 to FE7. The CANCEL PDU shall contain information elements as defined in table 18.

Table 18: Facility element coding for CANCEL PDU

Information element	Length	Type	C/O/M	Remark
SS type	6	1	M	Defined in ETS 300 392-9 [6]
CAD PDU type	5	1	M	CANCEL
SS-CAD intercepting SwMI call identifier	14	1	M	note 1 and note 2
NOTE 1:	Shall be as defined in ETS 300 392-2 [5], subclause 14.8.			
NOTE 2:	When ACCEPT PDU is call related, this information element is redundant			

6.1.6 DEACTIVATE PDU

DEACTIVATE PDU is offered from FE3 or FE7 to FE2. The DEACTIVATE PDU shall contain information elements as defined in table 19.

Table 19: Facility element coding for DEACTIVATE PDU

Information element	Length	Type	C/O/M	Remark
SS type	6	1	M	Defined in ETS 300 392-9 [6]
CAD PDU type	5	1	M	DEACTIVATE
Range type for restricted user	4	1	M	
Restricted user address type	2	1	M	note 1
Restricted user SSI	24	1	C	note 2; note 3
Restricted user extension	24	1	C	note 2; note 3
NOTE 1:	Shall be repeated as defined by the Range type for the restricted user.			
NOTE 2:	Shall be as defined by the Restricted user address type element.			
NOTE 3:	Defined in ETS 300 392-2 [5], subclauses 14.7 and 14.8.			

6.1.7 DEACTIVATE ACK PDU

DEACTIVATE ACK PDU is offered from FE2 to FE3 or FE7. The DEACTIVATE ACK PDU shall contain information elements as defined in table 20.

When the Deactivation result information element values are different for different restricted users then FE2 will send multiple DEACTIVATE ACK PDUs one for each different deactivation result. The multiple user mask shall be according to the range used in that DEACTIVATION ACK PDU and it may be different than the range in the corresponding DEACTIVATE PDU.

When the Deactivation result information element indicates "Accepted", then each "1" bit in the Multiple user mask information element shall indicate users who's SS-CAD restrictions are deactivated.

When the Deactivation result information element indicates "Not accepted", then each "1" bit in the Multiple user mask information element shall indicated users against which deactivation of the SS-CAD restrictions are failed. The SS-CAD restrictions state of those users can be either "activated" or "deactivated" and the actual state is not indicated in the DEACTIVATE ACK PDU.

Table 20: Facility element coding for DEACTIVATE ACK PDU

Information element	Length	Type	C/O/M	Remark
SS type	6	1	M	Defined in ETS 300 392-9 [6]
CAD PDU type	5	1	M	DEACTIVATE ACK
Range type for restricted user	4	1	M	
Restricted user address type	2	1	M	note 1
Restricted user SSI	24	1	C	note 2; note 3
Restricted user extension	24	1	C	note 2; note 3
Multiple user mask present	1	1	M	
Multiple user mask	Variable	1	C	note 4
Deactivation result	1	1	M	note 5
Deactivation failure reason	7	1	C	note 6
NOTE 1:	Shall be repeated as defined by the Range type for the restricted user.			
NOTE 2:	Shall be as defined by the Restricted user address type element.			
NOTE 3:	Defined in ETS 300 392-2 [5], subclauses 14.7 and 14.8.			
NOTE 4:	This information element shall be present only when the Multiple user mask present information element indicates "Present". This information element shall be used, when the activation result information element is valid only against a subset of the restricted users. The length of the information element shall be equal to the number of users in the range for restricted users.			
NOTE 5:	This information element shall indicate deactivation result against those restricted users indicated in the Multiple user mask information element or all users in the range when the Multiple user result information element is omitted.			
NOTE 6:	This information element shall be present only when the deactivation result is "Not accepted".			

6.1.8 DEFINE PDU

DEFINE PDU is offered from FE3 or FE7 to FE2. The DEFINE PDU shall contain information elements as defined in table 21.

Table 21: Facility element coding for DEFINE PDU

Information element	Length	Type	C/O/M	Remark
SS type	6	1	M	Defined in ETS 300 392-9 [6]
CAD PDU type	5	1	M	DEFINE
Range type for restricted user/users	4	1	M	
Restricted user address type	2	1	M	note 4
Restricted user SSI	24	1	C	note 1; note 2
Restricted user extension	24	1	C	note 1; note 2
Type of restriction change	4	1	M	
Activation type	1	1	M	
Interception type	1	1	M	
Basic service restriction - called party	2	1	M	
Basic service restriction - calling party	2	1	M	
Range type for dispatcher/dispatchers	4	2	O	
Dispatcher address type	2	2	C	note 4
Dispatcher SSI	24	2	C	note 1; note 2
Dispatcher extension	24	2	C	note 1; note 2
Range type for restricted source/sources	4	2	O	
Restricted source address type	2	2	C	note 4
Restricted source SSI	24	2	C	note 1; note 2
Restricted source extension	24	2	C	note 1; note 2
Range type for restricted destination/destinations	4	2	O	
Restricted destination address type	2	2	C	note 4
Restricted destination SSI	24	2	C	note 1; note 2
Restricted destination extension	24	2	C	note 1; note 2
Restricted destination external subscriber number	variable	2	C	note1; note 5
Range type for restricted area/areas	4	2	O	
Restricted area	4	2	C	note 3; note 4
NOTE 1:	Shall be as defined by the restricted user/source/destination/dispatcher address type information element.			
NOTE 2	Defined in ETS 300 392-2 [5], subclauses 14.7 and 14.8.			
NOTE 3:	Defined in ETS 300 392-2 [5], subclause 14.8.1.			
NOTE 4:	Shall be repeated as defined by the preceding Range type information element.			
NOTE 5:	This information element shall contain (sub)element or (sub)elements as defined in ETS 300 392-9 [6], clause 8.4.4.			

6.1.9 DEFINE ACK PDU

DEFINE ACK PDU is offered from FE2 to FE3 or FE7. The DEFINE ACK PDU shall contain information elements as defined in table 22.

When definition result information element values are different for different restricted users then FE2 will send multiple DEFINE ACK PDUs one for each different definition result. The multiple user mask shall be according to the range used in that DEFINE ACK PDU and it may be different than the range in the corresponding DEFINE PDU.

When the Definition result information element indicates "Accepted", then each "1" bit in the Multiple user mask information element shall indicate users who's SS-CAD restrictions are defined.

When the Definition result information element indicates "Not accepted", then each "1" bit in the Multiple user mask information element shall indicate users against which definition of the SS-CAD restrictions are failed.

Table 22: Facility element coding for DEFINE ACK

Information element	Length	Type	C/O/M	Remark
SS type	6	1	M	Defined in ETS 300 392-9 [6]
CAD PDU type	5	1	M	DEFINE
Range type for restricted users	4	1	M	
Restricted user address type	2	1	M	note 1;
Restricted user SSI	24	1	C	note 2; note 3
Restricted user extension	24	1	C	note 2; note 3
Multiple user mask present	1	1	M	
Multiple user mask	Variable	1	C	note 4
Definition result	1	1	M	note 5
Definition failure reason	6	1	C	note 6
NOTE 1:	Shall be repeated as defined by the Range type for the restricted user.			
NOTE 2:	Shall be as defined by the Restricted user address type information element.			
NOTE 3:	Defined in ETS 300 392-2 [5], subclauses 14.7 and 14.8.			
NOTE 4:	This information element shall be present only when the Multiple user mask present information element indicates "Present". This information element shall be used, when the definition result information element is valid only against a subset of the restricted users. The length of the information element shall be equal to the number of users in the range for restricted users.			
NOTE 5:	This information element shall indicate the definition result against those restricted users indicated in the Multiple user mask information element or all users in the range when the Multiple user result information element is omitted.			
NOTE 6:	This information element shall be present only when the definition result is "Not accepted".			

6.1.10 DIVERT PDU

DIVERT PDU is offered from FE7 to FE2. The DIVERT PDU shall contain information elements as defined in table 23.

Table 23: Facility element coding for DIVERT PDU

Information element	Length	Type	C/O/M	Remark
SS type	6	1	M	Defined in ETS 300 392-9 [6]
CAD PDU type	5	1	M	DIVERT
SS-CAD intercepting SwMI call identifier	14	1	M	Defined in ETS 300 392-2 [5], subclause 14.8

6.1.11 DIVERTED PDU

DIVERTED PDU is offered from FE2 to FE1. The DIVERTED PDU shall contain information elements as defined in table 24.

Note that when this PDU is sent over the ISI (using ANF-ISISS), the information element "call diverted to a dispatcher" shall be set to 1 in the ISI CONNECT PDU.

Table 24: Facility element coding for DIVERTED PDU

Information element	Length	Type	C/O/M	Remark
SS type	6	1	M	Defined in ETS 300 392-9 [6]
CAD PDU type	5	1	M	DIVERTED
Interception cause	5	1	M	
Dispatcher address type	2	2	O	
Dispatcher SSI	24	2	C	note 1; note 2
Dispatcher extension	24	2	C	note 1; note 2
NOTE 1:	Shall be as defined by the Dispatcher address type element.			
NOTE 2:	Defined in ETS 300 392-2 [5], subclauses 14.7 and 14.8.			

6.1.12 INTERCEPTED PDU

INTERCEPTED PDU is offered from FE2 to FE1. The INTERCEPTED PDU shall contain information elements as defined in table 25.

Table 25: Facility element coding for INTERCEPTED PDU

Information element	Length	Type	C/O/M	Remark
SS type	6	1	M	Defined in ETS 300 392-9 [6]
CAD PDU type	5	1	M	INTERCEPTED
Interception cause	5	1	M	
Dispatcher address type	2	2	O	
Dispatcher SSI	24	2	C	note 1; note 2
Dispatcher extension	24	2	C	note 1; note 2
NOTE 1:	Shall be as defined by the Dispatcher address type element.			
NOTE 2:	Defined in ETS 300 392-2 [5], subclauses 14.7 and 14.8.			

6.1.13 INTERROGATE PDU

INTERROGATE PDU is offered from FE3 or FE7 to FE2. The INTERROGATE PDU shall contain information elements as defined in table 26.

Table 26: Facility element coding for INTERROGATE PDU

Information element	Length	Type	C/O/M	Remark
SS type	6	1	M	Defined in ETS 300 392-9 [6]
CAD PDU type	5	1	M	INTERROGATE
Restricted user address type	2	1	M	
Restricted user SSI	24	1	C	note 1; note 2
Restricted user extension	24	1	C	note 1; note 2
NOTE 1:	Shall be as defined by the Restricted user address type element.			
NOTE 2:	Defined in ETS 300 392-2 [5], subclauses 14.7 and 14.8.			

6.1.14 INTERROGATE ACK PDU

INTERROGATE ACK PDU is offered from FE2 to FE3 or FE7. The INTERROGATE ACK PDU shall contain information elements as defined in table 27.

When interrogation result information element values are different for different restricted users then FE2 will send multiple INTERROGATE ACK PDUs one for each different interrogation result. The multiple user result shall be according to the range used in that INTERROGATE ACK PDU and it may be different than the range in the corresponding INTERROGATE PDU.

Table 27: Facility element coding for INTERROGATE ACK PDU

Information element	Length	Type	C/O/M	Remark
SS type	6	1	M	Defined in ETS 300 392-9 [6]
CAD PDU type	5	1	M	INTERROGATE ACK
Range type for restricted users	4	1	M	
Restricted user address type	2	1	M	note 1
Restricted user SSI	24	1	C	note 2; note 3
Restricted user extension	24	1	C	note 2; note 3
Multiple user mask present	1	1	M	
Multiple user mask result	Variable	1	C	note 4
Interrogation result	1	1	M	
Interrogation failure reason	3	1	C	note 5
Activation type	1	1	C	note 6
Interception type	1	1	C	note 6
Basic service restriction - called party	2	1	C	note 6
Basic service restriction - calling party	2	1	C	note 6
Range type for dispatcher/dispatchers	4	2	O	note 7
Dispatcher address type	2	2	C	note 8
Dispatcher SSI	24	2	C	note 2; note 3
Dispatcher extension	24	2	C	note 2; note 3
Range type for restricted source/sources	4	2	O	note 7
Restricted source address type	2	2	C	note 8
Restricted source SSI	24	2	C	note 2; note 3
Restricted source extension	24	2	C	note 2; note 3
Range type for restricted destination/destinations	4	2	O	note 7
Restricted destination address type	2	2	C	note 8
Restricted destination SSI	24	2	C	note 2; note 3
Restricted destination extension	24	2	C	note 2; note 3
Restricted destination external subscriber number	variable	2	C	note2; note 9
Range type for restricted areas	4	2	O	note 7
Restricted area	4	2	C	note 8; note 10
NOTE 1:	Shall be repeated as defined by the Range type for the restricted user.			
NOTE 2:	Shall be as defined by the Restricted user address type information element.			
NOTE 3:	Defined in ETS 300 392-2 [5], subclauses 14.7 and 14.8.			
NOTE 4:	This information element shall be present only when the Multiple user mask present information element indicates "Present". This information element shall be used, when the definition result information element is valid only against a subset of the restricted users. The length of the information element shall be equal to the number of users in the range for restricted users.			
NOTE 5:	Shall be present only when the interrogation result is "Not accepted".			
NOTE 6:	Shall be present when the interrogation result is "Accepted".			
NOTE 7:	Shall not be present when the interrogation result "Not accepted".			
NOTE 8:	Shall be repeated as defined by the preceding Range type element.			
NOTE 9:	This information element shall contain (sub)element or (sub)elements as defined in ETS 300 392-9 [6], clause 8.4.4.			
NOTE 10:	Defined in ETS 300 392-2 [5], subclause 14.8.1.			

6.1.15 PROFILE and PROFILE ACK information elements

PROFILE and PROFILE ACK information elements are exchanged between FE2s upon migration of an individual user or when SS-CAD definition is modified. The PROFILE and PROFILE ACK information elements shall contain information elements as defined in table 28.

Table 28: Facility element coding for PROFILE and PROFILE ACK information elements

Information element	Length	Type	C/O/M	Remark
Restricted user address type	2	1	M	
Restricted user SSI	24	1	C	note 1; note 2
Restricted user extension	24	1	C	note 1; note 2
Activation type	1	1	M	
Interception type	1	1	M	
Basic service restriction - called party	2	1	M	
Basic service restriction - calling party	2	1	M	
Range type for dispatcher/dispatchers	4	2	O	
Dispatcher address type	2	2	C	note 3
Dispatcher SSI	24	2	C	note 1; note 2
Dispatcher extension	24	2	C	note 1; note 2
Range type for restricted source/sources	4	2	O	
Restricted source address type	2	2	C	note 3
Restricted source SSI	24	2	C	note 1; note 2
Restricted source extension	24	2	C	note 1; note 2
Range type for restricted destination/destinations	4	2	O	
Restricted destination address type	2	2	C	note 3
Restricted destination SSI	24	2	C	note 1; note 2
Restricted destination extension	24	2	C	note 1; note 2
Restricted destination external subscriber number mask	variable	2	C	note 1, note 4
Range type for restricted areas	4	2	O	
Restricted area	4	2	C	note 3; note 5
NOTE 1:	Shall be as defined by the Restricted user address type information element.			
NOTE 2:	Defined in ETS 300 392-2 [5], subclauses 14.7 and 14.8.			
NOTE 3:	Shall be repeated as defined by the preceding Range type element.			
NOTE 4:	This information element shall contain (sub)element or (sub)elements as defined in ETS 300 392-9 [6], subclause 8.4.4.			
NOTE 5:	Defined in ETS 300 392-2 [5], subclause 14.8.1.			

6.1.16 REJECT PDU

REJECT PDU is offered from FE7 to FE2. The REJECT PDU shall contain information elements as defined in table 29.

Table 29: Facility element coding for REJECT PDU

Information element	Length	Type	C/O/M	Remark
SS type	6	1	M	Defined in ETS 300 392-9 [6]
CAD PDU type	5	1	M	REJECT
SS-CAD intercepting SwMI call identifier	14	1	M	note 1 and note 2
Rejection cause	5	1	M	
NOTE 1:	Shall be as defined in ETS 300 392-2 [5], subclause 14.8.			
NOTE 2:	When ACCEPT PDU is call related, this information element is redundant.			

6.1.17 REJECTED PDU

REJECTED PDU is offered from FE2 to FE1. The REJECTED PDU shall contain information elements as defined in table 30.

Table 30: Facility element coding for REJECTED PDU

Information element	Length	Type	C/O/M	Remark
SS type	6	1	M	Defined in ETS 300 392-9 [6]
CAD PDU type	5	1	M	REJECTED
Dispatcher address type	2	2	C	
Dispatcher SSI	24	2	C	note 1; note 2
Dispatcher extension	24	2	C	note 1; note 2
Rejection cause	5	1	M	
NOTE 1:	Shall be as defined by the Dispatcher address type information element.			
NOTE 2:	Defined in ETS 300 392-2 [5], subclauses 14.7 and 14.8.			

6.1.18 REQUEST PDU

REQUEST PDU is offered from FE2 to FE7. The REQUEST PDU shall contain information elements as defined in table 31.

The calling and called party address type shall be included when SS-CAD has been invoked because of source or destination restrictions. This shall hold for the calling party even if SS-CLIR has been invoked for the calling party.

In theory no calling or called party information is needed when the REQUEST PDU is sent together with the ANF-ISIIC SETUP PDU (i.e. when the call is automatically diverted to the dispatcher), since such information is already included in this SETUP PDU. However, it shall nevertheless be included whenever such information has to be delivered to the dispatcher since the SwMI where the dispatcher is registered may not be able to add it in the CAD REQUEST PDU which it receives from the ISI (in case it would not support SS-CAD).

Table 31: Facility element coding for REQUEST PDU

Information element	Length	Type	C/O/M	Remark
SS type	6	1	M	Defined in ETS 300 392-9 [6]
CAD PDU type	5	1	M	REQUEST
SS-CAD intercepting SwMI call identifier	14	1	M	Defined in ETS 300 392-2 [5], subclause 14.8
Interception cause	5	1	M	
Calling party address type	2	2	O	
Calling party SSI	24	2	C	note 1; note 2
Calling party extension	24	2	C	note 1; note 2
Calling external subscriber number length	5	2	C	note 1; note 3
Calling external subscriber number	variable	2	C	note 3; note 4
Called party address type	2	2	O	
Called party SSI	24	2	C	note 5; note 2
Called party extension	24	2	C	note 5; note 2
Called external subscriber number length	5	2	C	note 5; note 6
Called external subscriber number	variable	2	C	note 6; note 4
MNI	24	2	O	note 7
Restricted area - calling user	4	2	O	
Restricted area - called user	4	2	O	
Basic service restriction - calling party	2	2	O	
Basic service restriction - called party	2	2	O	
NOTE 1:	Shall be as defined by the Calling party address type information element.			
NOTE 2:	Shall be as defined in ETS 300 392-2 [5], subclauses 14.7 and 14.8.			
NOTE 3:	The Calling external subscriber number length information element shall indicate number of the digits in the calling external subscriber number information element.			
NOTE 4:	Defined in ETS 300 392-2 [5], subclause 14.8.20.			
NOTE 5:	Shall be as defined by the Called party address type information element.			
NOTE 6:	The Called external subscriber number length shall indicate number of the digits in the called external subscriber number information element.			
NOTE 7:	MNI of the SwMI sending this request. Only sent if FE7 is in a different SwMI to SS-CAD intercepting SwMI.			

6.2 Information element coding

6.2.1 Activation failure reason

The activation failure reason information element is a bit-mapped field indicating the reason for an activation not being accepted. The meaning of each bit setting in this element shall be as defined in table 32.

NOTE: The failure reason information element may not fully describe all reasons for rejection.

Table 32: Activation failure reason contents

Information element	Length	Value	Remark
Activation/Deactivation failure reason	7	00000002	Rejected for undefined reason
		00000012	Not authorized restricted user
		00000102	Not valid restricted user
		00001002	Not authorized dispatcher
		00010002	Not valid dispatcher
		00100002	No dispatchers available
		01000002	Undecodeable PDU
		10000002	Range not supported (see note)
NOTE:	Refer to ETS 300 392-9 [6], subclause 8.3.2.		

6.2.2 Activation result

The activation result information element shall indicate activation whether activation was accepted as defined in table 33.

Table 33: Activation result contents

Information element	Length	Value	Remark
Activation result	1	0	Not accepted
		1	Accepted

6.2.3 Activation type

The activation type information element shall indicate whether SS-CAD is activated as defined in table 34.

Table 34: Activation type contents

Information element	Length	Value	Remark
Activation type	1	0	Not activated
		1	Activated

6.2.4 Basic service restriction - called party

The basic service restriction - called party information element shall indicate the type of basic service which is restricted for incoming calls as defined in table 35.

Table 35. Basic service restriction contents

Information element	Length	Value	Remark
Basic service restriction	2	0	No restrictions
		1	Speech service
		2	Data service
		3	Speech and data service

6.2.5 Basic service restriction - calling party

The basic service restriction - calling party information element shall indicate the type of basic service which is restricted for outgoing calls as defined in table 35.

6.2.6 CAD PDU type element

The CAD PDU Type information element shall indicate the action requested or the action response received as defined in table 36.

Table 36: CAD PDU type contents

Information element	Length	Value	Remark
CAD PDU type	5	0	See ETS 300 392-9
		1	See ETS 300 392-9
		2	ACTIVATE
		3	ACTIVATE ACK
		4	DEACTIVATE
		5	DEACTIVATE ACK
		6	DEFINE
		7	DEFINE ACK
		8	INTERROGATE
		9	INTERROGATE ACK
		10	INTERCEPTED
		11	REQUEST
		12	ACCEPT
		13	ACCEPTED
		14	CANCEL
		15	DIVERT
		16	DIVERTED
		17	REJECT
18	REJECTED		
19-31	Reserved		

6.2.7 Deactivation rejection reason

This information element shall have the values as defined in table 32.

6.2.8 Deactivation result

The deactivation result information element shall indicate whether deactivation was accepted as defined in table 37.

Table 37: Deactivation result contents

Information element	Length	Value	Remark
Deactivation result	1	0	Not accepted
		1	Accepted

6.2.9 Definition failure reason

The definition failure reason information element is a bit-mapped field indicating the reason for a definition not being accepted. The meaning of each bit setting in this information element shall be as defined in table 38.

NOTE: The failure reason information element may not fully describe all reasons for rejection.

Table 38: Definition failure reason contents

Information element	Length	Value	Remark
Definition failure reason	6	0000002	Rejected for undefined reason
		0000012	Not authorized source/destination/dispatcher identity
		0000102	Invalid source/destination/dispatcher identity
		0001002	Invalid area
		0010002	Not authorized basic service
		0100002	Undecodeable PDU
		1000002	Range not supported (see note)
NOTE: Refer to ETS 300 392-9 [6], subclause 8.3.2.			

6.2.10 Definition result

Definition result shall indicate whether the previously made definition request was successful or unsuccessful. Definition result information element shall be as defined in table 39.

Table 39: Definition result contents

Information element	Length	Value	Remark
Definition result	1	02	Not accepted
		12	Accepted

6.2.11 Dispatcher address type

The dispatcher type identifier information element shall indicate the type of dispatcher address that shall follow this element, refer to ETS 300 392-9 [6]. The element value encoding shall be as defined in table 40.

Table 40: Dispatcher address type contents

Information element	Length	Value	Remark
Dispatcher address type	2	0	Short Number Address (SNA)
		1	Short Subscriber Identity (SSI)
		2	TETRA Subscriber Identity (TSI)
		3	External subscriber number

6.2.12 Interception cause

The interception cause information element is a bit-mapped field and shall give the cause for the call being intercepted by the dispatcher as defined in table 41.

Table 41: Interception cause contents

Information element	Length	Value	Remark
Interception cause	5	000002	Reason not defined
		000012	Restricted basic service
		000102	Restricted destination address
		001002	Restricted source address
		010002	Restricted area
		100002	Reserved

6.2.13 Interception type

The Interception type information element shall define if immediate set-up or dispatcher requested set-up is valid for this request as defined in table 42.

Table 42: Interception type contents

Information element	Length	Value	Remark
Interception cause	1	0	Immediate set-up
		1	Dispatcher requested set-up

6.2.14 Interrogation failure reason

The interrogation failure reason information element shall define the course of unsuccessful interrogation as defined in ETS 300 392-9 [6], subclause 8.4.5.

6.2.15 Interrogation result

Interrogation result shall indicate whether the previously made interrogation request was successful or unsuccessful. Interrogation result information element shall be as defined in table 43.

Table 43: Interrogation result contents

Information element	Length	Value	Remark
Interrogation result	1	02	Not accepted
		12	Accepted

6.2.16 Multiple user mask

The multiple user mask information element shall indicate for which identities in the preceding list or range of restricted users the indicated result or action is valid as defined in ETS 300 392-9 [6].

6.2.17 Range type

See ETS 300 392-9 [6] for the encoding of this element.

6.2.18 Rejection cause

The rejection cause information element shall indicate why the call set-up to user A has been rejected by the dispatcher as defined in table 41.

6.2.19 Restricted basic service

The restricted basic service element shall define which basic service is restricted as listed in table 44.

Table 44: Restricted basic service contents

Information element	Length	Value	Remark
Restricted basic service	2	0	None
		1	Basic service information - calling party
		2	Basic service information - called party
		3	Both parties

6.2.20 Restricted destination address type

The restricted destination address type information element shall indicate the type of restricted destination address that shall follow this element, refer to ETS 300 392-9 [6]. The element value encoding shall be as defined in table 40.

6.2.21 Restricted destination external subscriber number

This information element shall contain (sub)element or (sub)elements as defined in ETS 300 392-9 [6], subclause 8.4.4.

6.2.22 Restricted parties

The restricted parties information element shall define which of the parties in a call have a restriction as listed in table 45.

Table 45: Restricted parties contents

Information element	Length	Value	Remark
Restricted parties	2	0	None
		1	Calling party
		2	Called party
		3	Both parties

6.2.23 Restricted source address type

The restricted source address type information element shall indicate the type of restricted source address that shall follow this element, refer to ETS 300 392-9 [6]. The element value encoding shall be as defined in table 40.

6.2.24 Restricted user address type

The restricted user address type information element shall indicate the type of restricted user address that shall follow this element, refer to ETS 300 392-9 [6]. The element value encoding shall be as defined in table 40.

6.2.25 Type of restriction change

The type of restriction change information element shall define the action of the following elements as listed in table 46.

Table 46: Type of restriction change contents

Information element	Length	Value	Remark
Type of restriction change	4	0	No modification of the actual restriction value
		1	Delete following specified restrictions
		2	Delete all restrictions
		3	Add following specified restrictions
		4	Add restrictions to all elements
		5-15	Reserved

6.3 SS-CAD protocol states

The protocol states of each of the SS-CAD functional entities are described in the following SDL diagrams. The convention used in the figures below is that output signals to the left represent primitives towards the user and output signals to the right represents information flow towards the SwMI part of the CAD function. Input signals from the left represent primitives from the user and input signals from the right represent information flows from the central part of the SwMI.

The behaviour of each FE is shown using the Specification and Description Language (SDL) defined in CCITT Recommendation Z.100 [1].

6.4 Protocol states for FE1

The signal routes used by FE1 are detailed in figure 1.

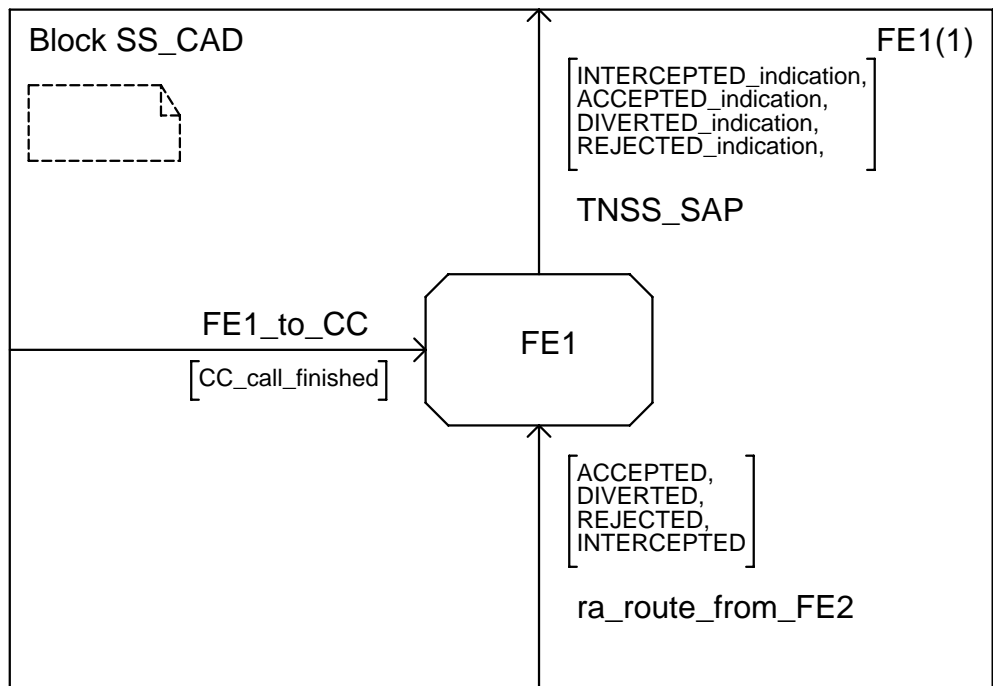

Figure 1: FE1 signal routes

The protocol states used in FE1 are shown in figure 2.

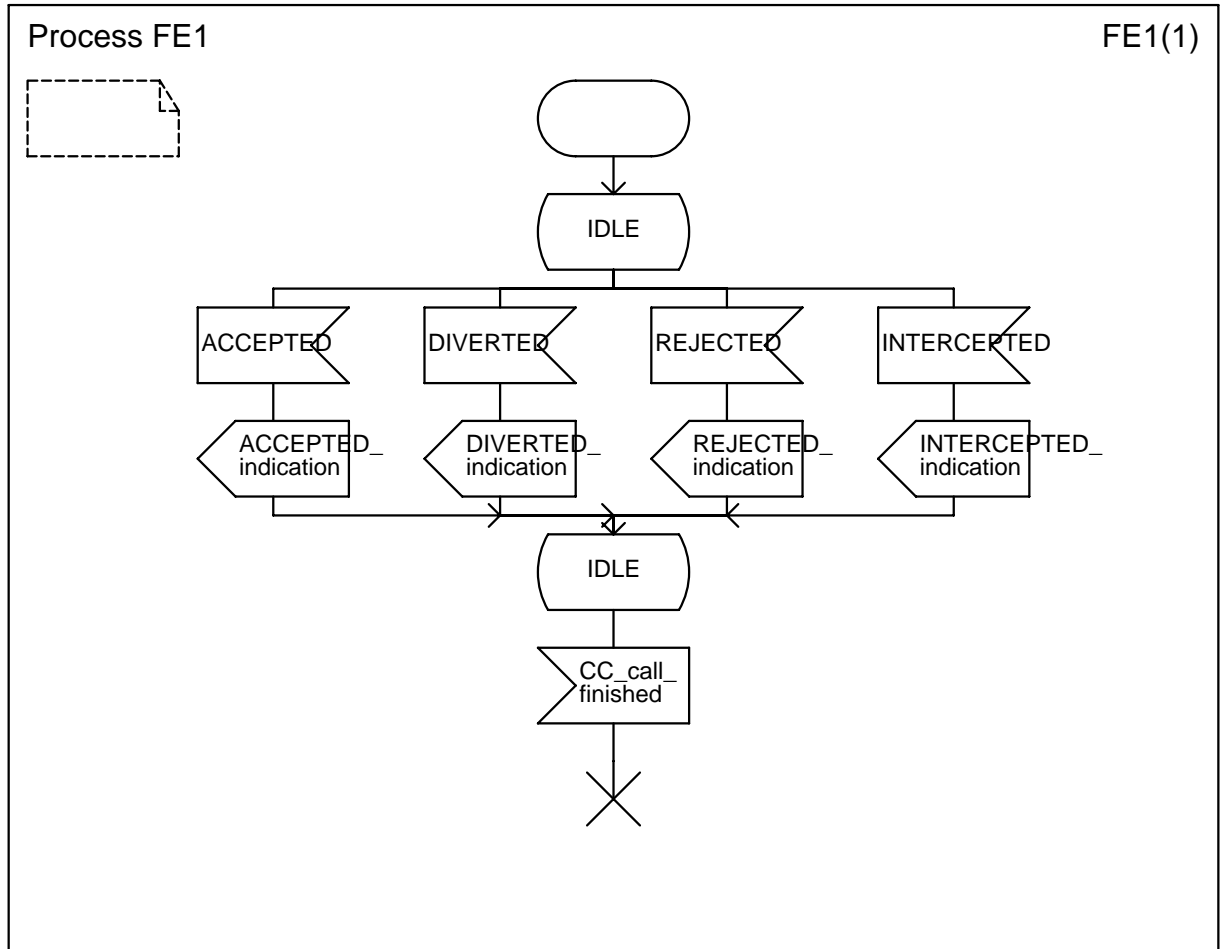

Figure 2: FE1 protocol states

6.4.1 Protocol states for FE2

The signal routes used by FE2 are detailed in figure 3.

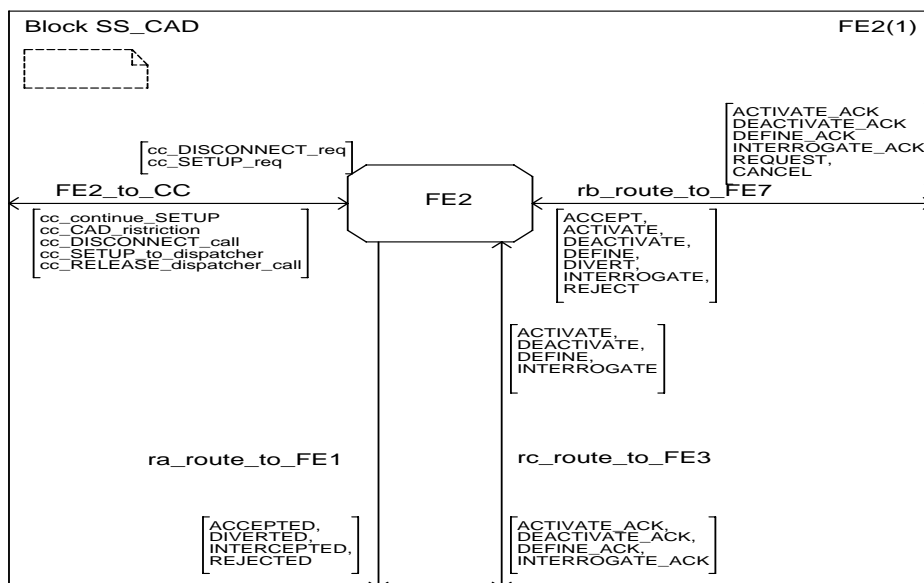

Figure 3: FE2 signal routes

The protocol states used in FE2 are shown in figures 4, 5, 6 and 7.

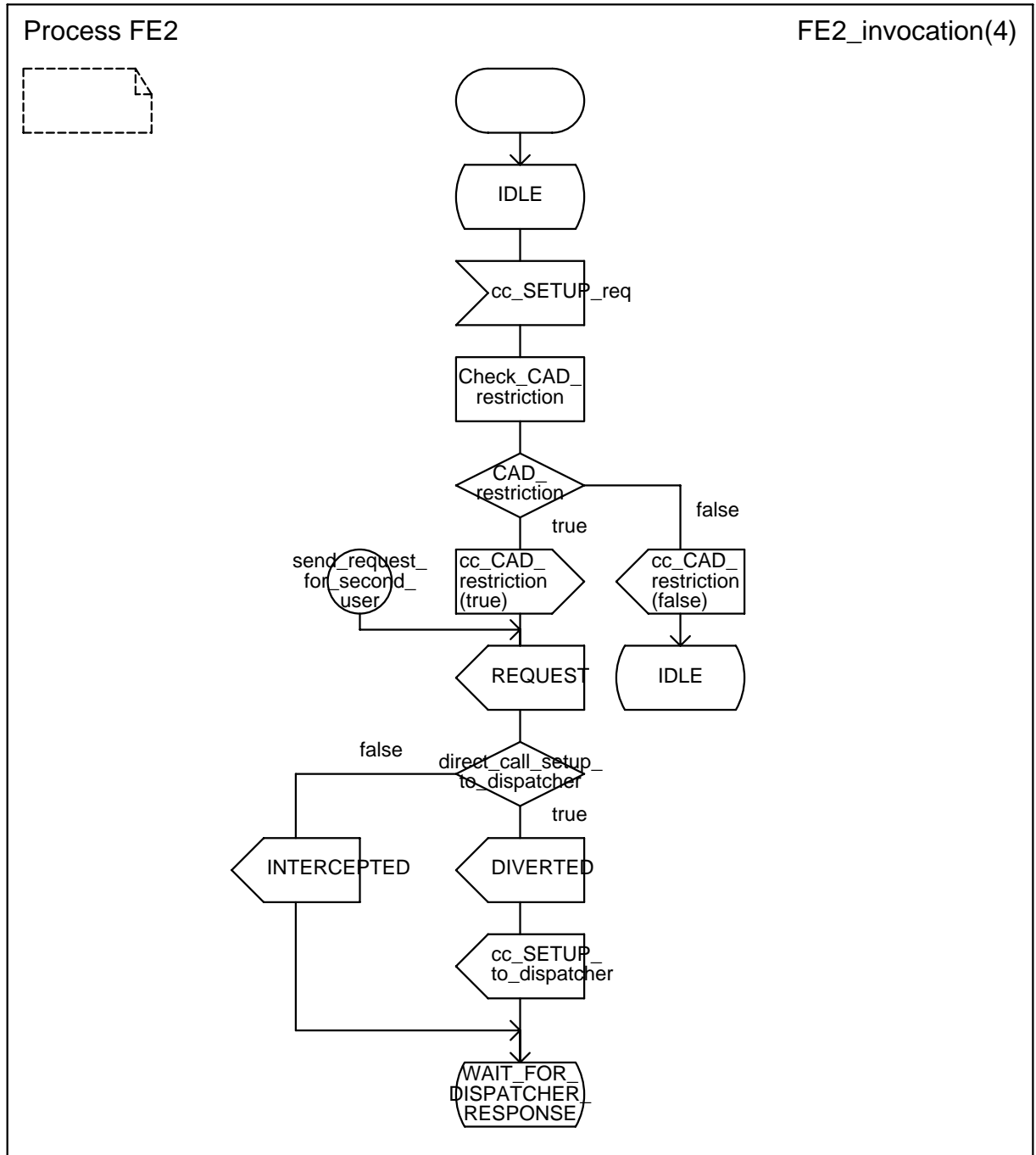

Figure 4: FE2 protocol state - invocation

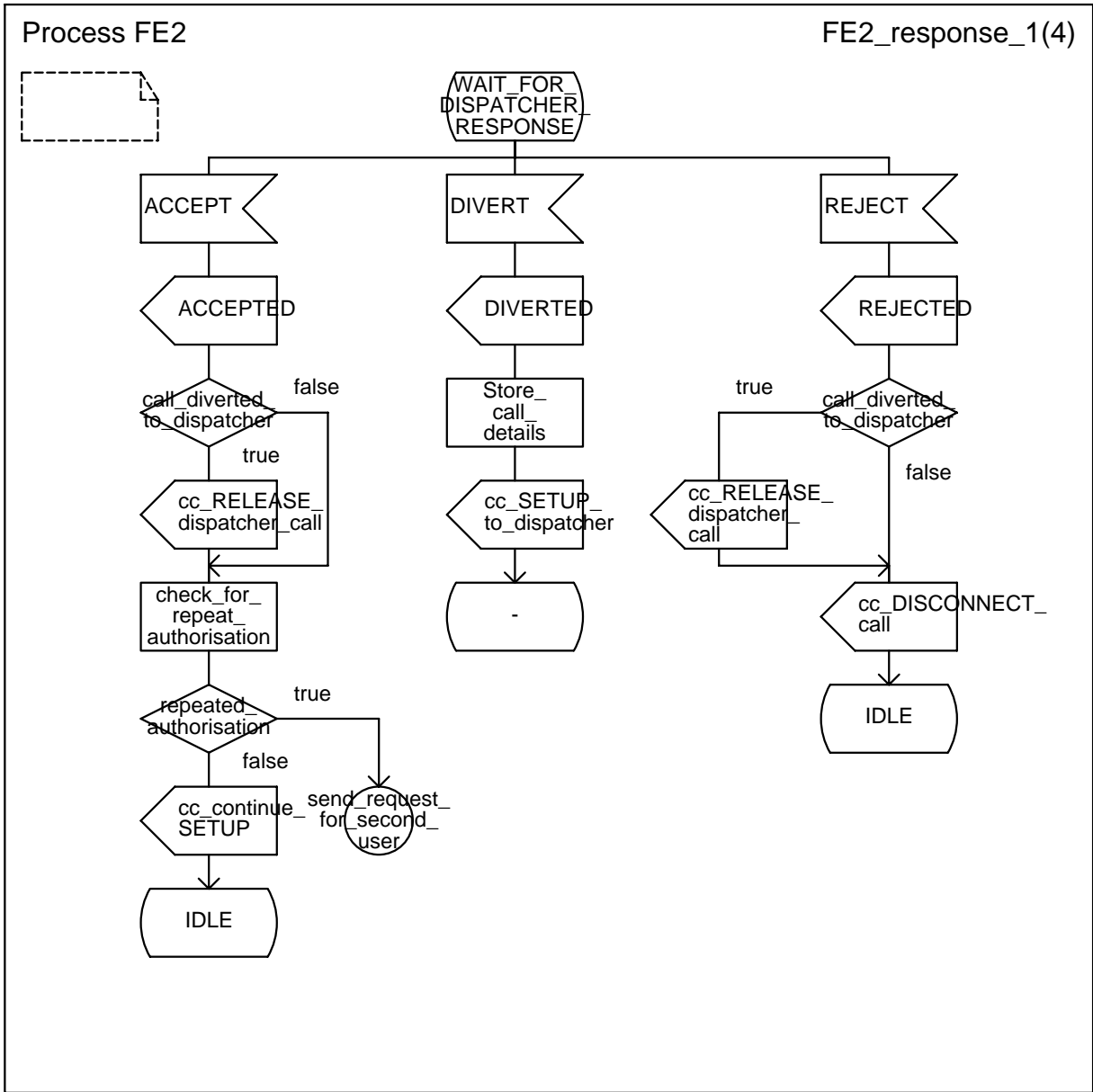

Figure 5: FE2 protocol states - responses

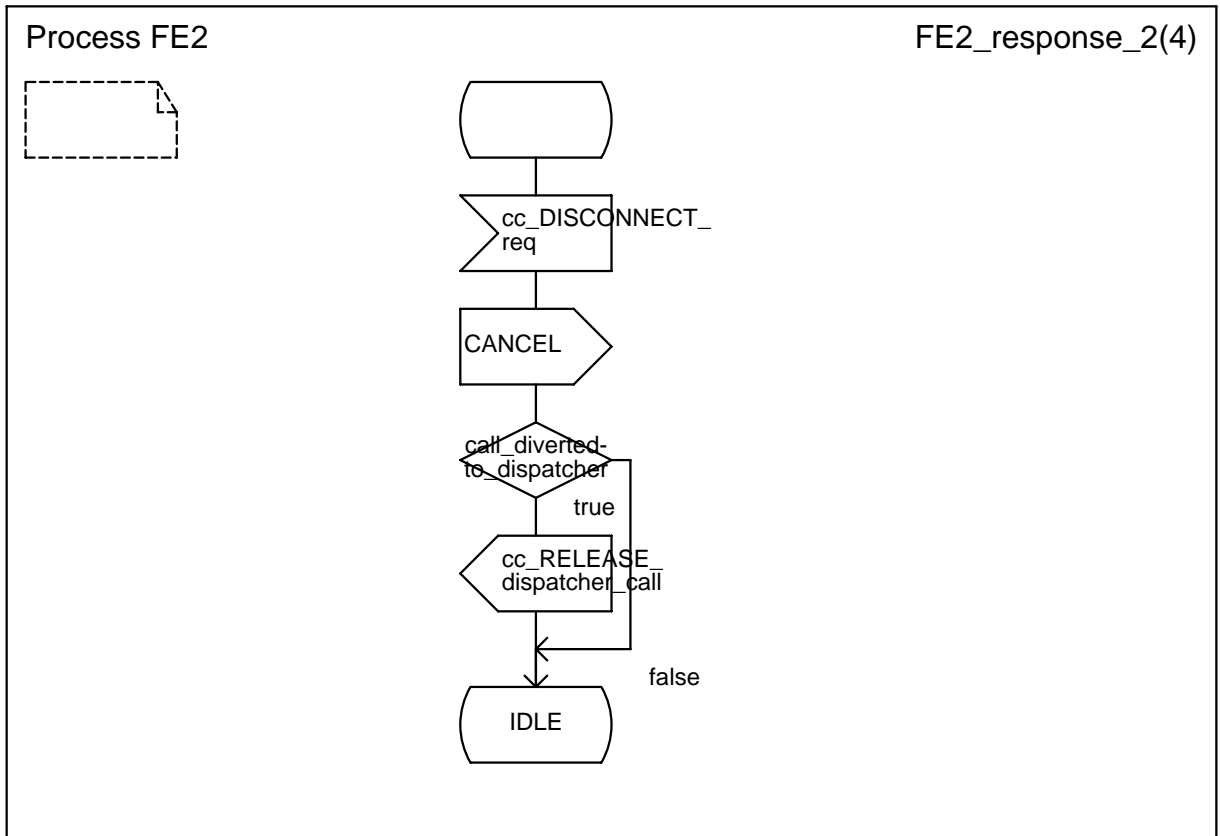

Figure 6: FE2 protocol states - responses (continued)

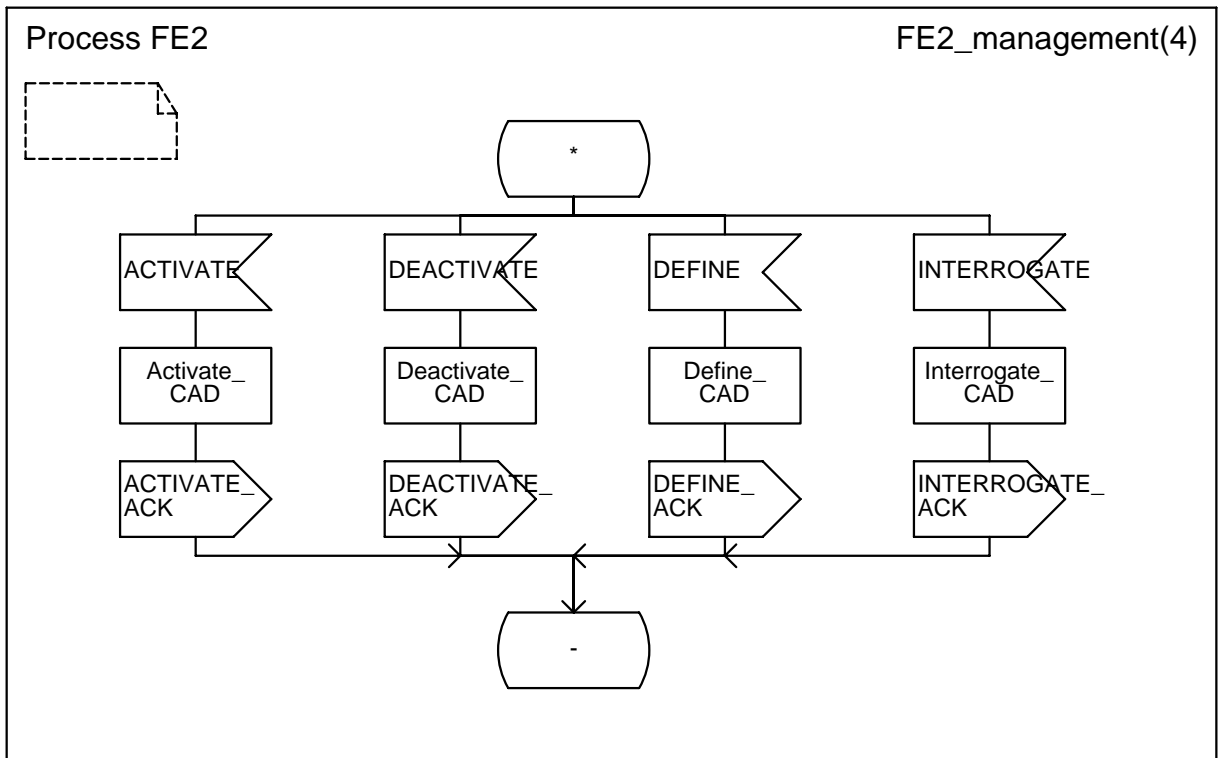

Figure 7: FE2 protocol states - management

6.4.2 Protocol states for FE3

The signal routes used by FE3 are detailed in figure 8.

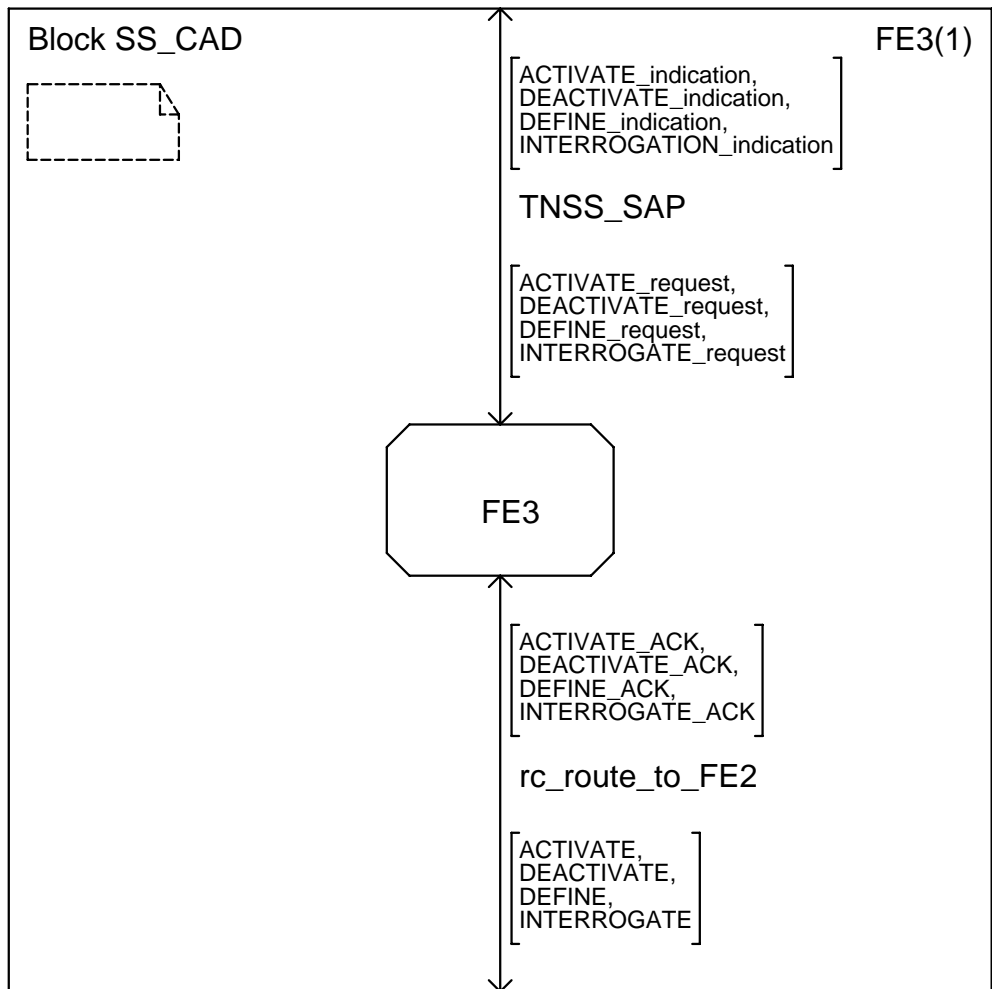

Figure 8: FE3 signal routes

The protocol states used in FE3 are shown in figure 9.

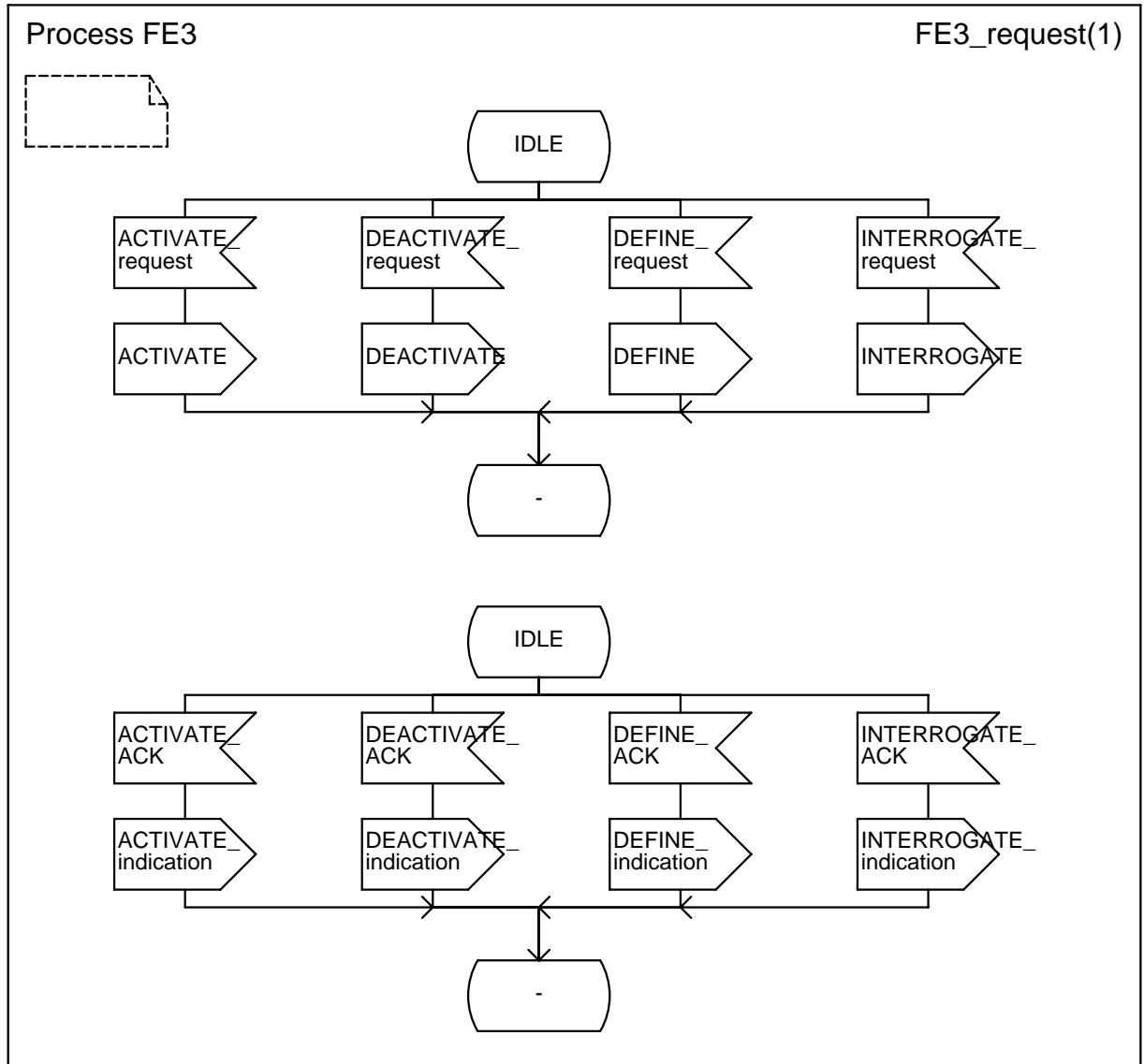

Figure 9: FE3 protocol states

6.4.3 Protocol states for FE7

The signal routes used by FE7 are detailed in figure 10

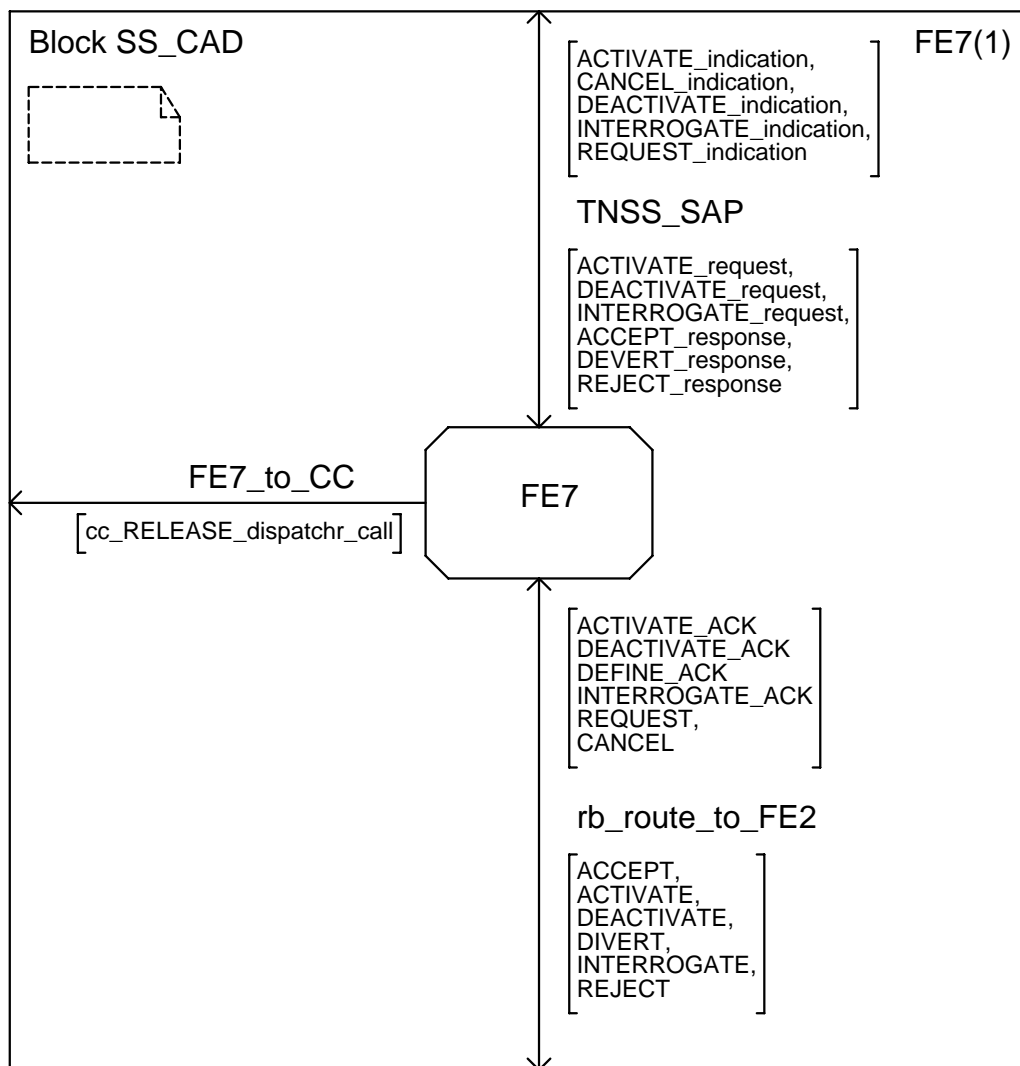

Figure 10: FE7 signal routes

The protocol states used in FE7 are shown in figures 11 and 12.

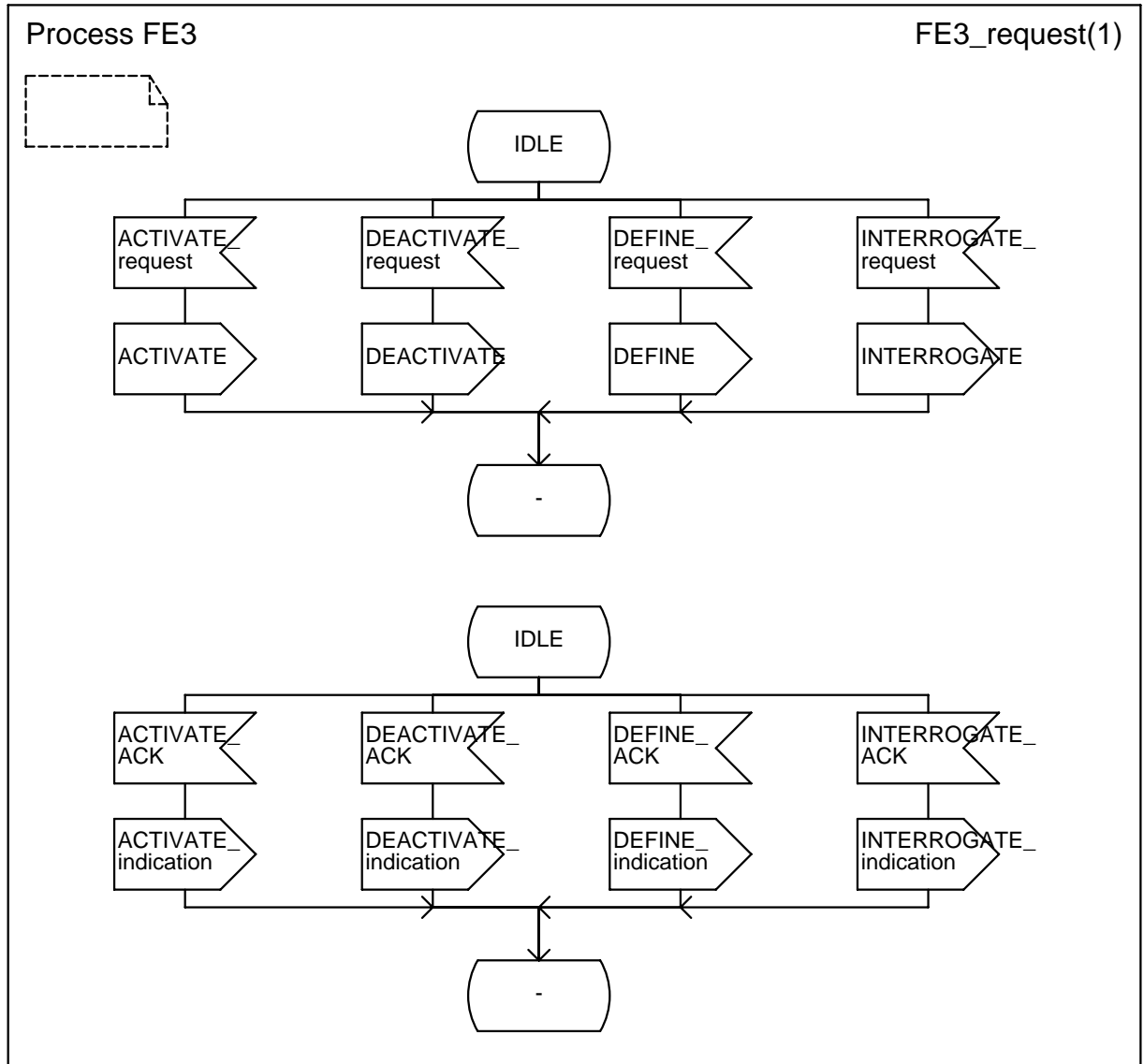

Figure 11: FE7 protocol states - request

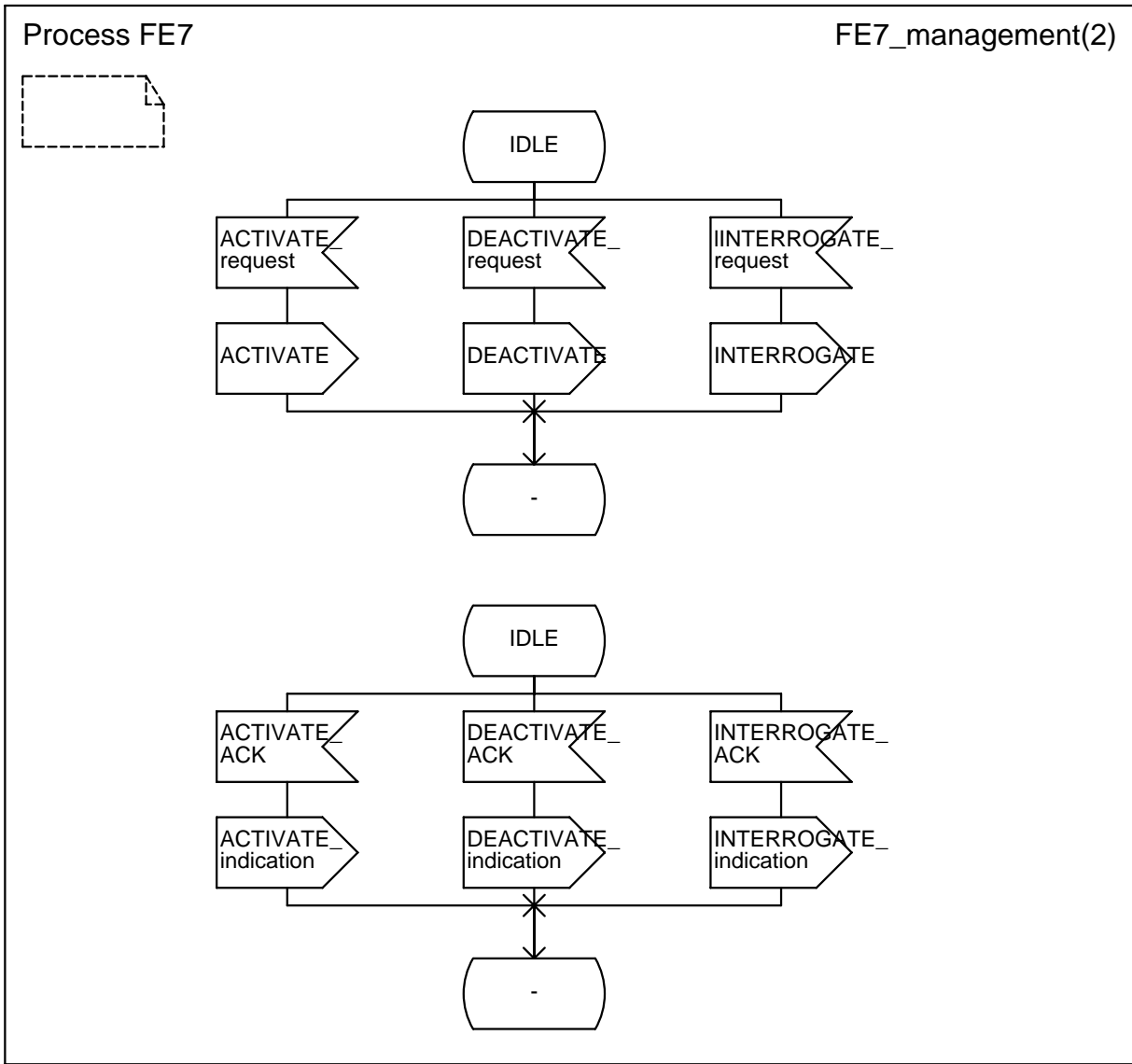

Figure 12: FE7 protocol states - management

6.5 Procedures

This supplementary service shall modify CC functions as defined in the following protocols. A formal information exchange between the SS-CAD entity and the CC entity is outside the scope of this ETS. This subclause describes the procedures identified in the SDL diagrams in the previous subclause, but does not give a complete functional description of each Functional Entity.

6.5.1 General routing of SS information

Call related SS-CAD PDUs shall generally use facility element in a CMCE PDU having call identity of the related call. Those CMCE PDUs shall be routed over the air interface as defined in ETS 300 392-2 [5] and over ISI as defined in ETS 300 392-9 [6]. Certain SS-CAD PDUs to and from a dispatcher in operation of SS-CAD refer to a call but there is no need to set up a call to the dispatcher and in that situation call unrelated signalling shall be used as defined in the following subclauses.

6.5.2 Procedures for FE1

FE1 receives a number of PDUs from FE2 and sends a corresponding TNSS-CAD primitive to the Application. It also sends an indication to CC specifying whether the current call set-up shall be halted, continued or disconnected.

6.5.3 Procedures for FE2

6.5.3.1 CAD invocation procedures

For each incoming call to SwMI where SS-CAD may be invoked, this SwMI CC shall temporarily halt the call set-up procedure and send an internal request to FE2. FE2 shall then call Check_CAD_restriction to determine if SS-CAD is to be invoked either for the calling or the called TETRA address. If restrictions are identified, then the SS-CAD intercepting SwMI shall memorize the set-up information for continuation after call acceptance.

If no restrictions are identified the call set up shall normally continue to the destination.

6.5.3.2 Call authorization

If there are restrictions they can either be related to user A or to user B or to both. If there are restrictions for both, one or two dispatchers may authorize the call. The authorization can either be done with or without immediate call set-up to the dispatcher. If immediate call set-up is requested, a DIVERTED PDU shall be sent to the calling user A and SS-CAD intercepting SwMI shall divert the call to the dispatcher in sending a D-SETUP PDU to it or an ISI SETUP PDU to the SwMI where this dispatcher is registered with a REQUEST PDU. The SS-CAD intercepting SwMI or the dispatcher may modify the call to match dispatcher capabilities. If no immediate connection is established, restricted user A shall be informed with an INTERCEPTED PDU and a REQUEST PDU shall be sent to dispatcher using call un-related signalling, refer to ETS 300 392-9 [6]. For either case, FE2 moves to the WAIT_FOR_DISPATCHER_RESPONSE state. The dispatcher functional entity can respond to the SS-CAD intercepting SwMI with an ACCEPT or a REJECT PDU. In the case where the call has not been diverted (i.e. just intercepted), the dispatcher functional entity can also respond with a DIVERT PDU.

- **Call accepted:** if an ACCEPT PDU is received from the dispatcher entity in the WAIT_FOR_DISPATCHER_RESPONSE state, an ACCEPTED PDU shall be sent to FE1. If the call has been diverted to the dispatcher, CC shall be informed to release the section of the call to the dispatcher. FE2 then calls check_for_repeated_authorization and, if required, issues a REQUEST PDU for the second dispatcher in the same manner as the first. If no further authorization is needed, CC shall be informed to continue the memorized call set-up to user B. FE2 returns to the IDLE state.
- **Call diverted:** if a DIVERT PDU is received from the dispatcher entity in the WAIT_FOR_DISPATCHER_RESPONSE state, a DIVERTED PDU shall be sent to the restricted user A. The SS-CAD intercepting SwMI CC shall then divert the call to the dispatcher. To do it, the SS-CAD intercepting SwMI CC shall send a D-SETUP PDU to the MS/LS of the dispatcher if he is registered in the SS-CAD intercepting SwMI, or otherwise an ISI FORWARD SWITCHING SETUP PDU to the SwMI where this dispatcher is registered, refer to ETS 300 392-3-2 [7]. The SS-CAD intercepting SwMI or the dispatcher may modify the call to match dispatcher capabilities. The SS-CAD intercepting SwMI shall stay in the WAIT_FOR_DISPATCHER_RESPONSE state.

NOTE 1: When the call is diverted to the dispatcher and when the latter is not registered in the SS-CAD intercepting SwMI, the call diversion is operated by forward switching and not by re-routeing even in the case where the dispatcher would be registered in the originating SwMI.

- **Call rejected:** if a REJECT PDU is received from the dispatcher entity in the WAIT_FOR_DISPATCHER_RESPONSE state, a REJECTED PDU shall be sent to the restricted user A. If the call had been diverted to the dispatcher, CC shall be informed to release the call, otherwise it is informed to disconnect the connection to user A. FE2 returns to the IDLE state.

If the call is accepted without diversion to the dispatcher, then the call set-up to the original destination shall be resumed and continued as defined for the basic call.

If the call is diverted to the dispatcher, the contents of the original SETUP shall be memorized in the SS-CAD intercepting SwMI, then after the call acceptance the memorized call set to the original destination shall be resumed (refer to ETS 300 392-3-2 [7]) as originally requested, except possibly for the transmission grant information elements. The latter shall be set to the values corresponding to the transmission permission grant at the end of the call with the dispatcher, i.e. independently of their values in the original SETUP.

If the destination SwMI is different from both the originating SwMI and the SS-CAD intercepting SwMI, the latter shall send to it an ISI FORWARD SWITCHING SETUP PDU to the destination SwMI.

NOTE 2: After the call has been diverted to the dispatcher, the call establishment to the called user will be done by forward switching through the SS-CAD intercepting SwMI.

Note that the user B SwMI or user B or both may modify the call set-up such that it is different from the call between dispatcher and user A.

Still if the destination SwMI is different from both the originating SwMI and the SS-CAD intercepting SwMI, when the call set-up is completed to the destination the SS-CAD intercepting SwMI shall send an IS-THROUGH CONNECT PDU to the originating SwMI and through connect the call between the originating and destination SwMIs, refer to ETS 300 392-3-2 [7].

Upon reception of the ISI-THROUGH CONNECT PDU the originating SwMI shall send the ISI-THROUGH CONNECT ACKNOWLEDGE PDU, refer to ETS 300 392-3-2 [7].

NOTE 3: The call through connection to the original destination after the call acceptance may invoke other supplementary services such as SS-COLP and SS-TPI.

If the restricted user A disconnects the call during call authorization, CC shall inform FE2, and FE2 shall send a CANCEL PDU to FE3. If FE2 was in the WAIT_FOR_DISPATCHER_RESPONSE state and the call had been diverted to the dispatcher, CC shall be informed to release the call. After these actions FE2 returns to the IDLE state.

When the dispatcher is in another SwMI than the SS-CAD intercepting SwMI and there is not a call related signalling connection available, then the REQUEST PDUs shall be sent using ANF-ISISS and the ACCEPT, DIVERT and REJECT PDUs will be received by ANF-ISISS as defined in ETS 300 392-9 [6]. When the ACCEPT or INTERCEPTED PDU is to be sent over ISI to the user A and there is not yet a signalling connection established, then those shall be sent in a PSS1 PROGRESS message.

The operation of SS-CAD should not affect the call maintenance procedures on transmission granting as the call controlling SwMI is not changed due to the SS-CAD interception.

NOTE 4: This SS-CAD operation description assumes that also the group call set-up from the originating SwMI uses call related signalling. If the ANF-ISIGC uses a different call set-up arrangement then the required modifications to the SS-CAD operation will be described in the ANF-ISIGC.

6.5.3.3 Activation/deactivation procedures

When FE2 receives an ACTIVATE or DEACTIVATE PDU from FE3 or FE7, FE2 shall check that the dispatcher is authorized to make an activation/deactivation by calling Activate_CAD or Deactivate_CAD before SS-CAD is activated or deactivated for the specified TETRA identities. In all cases, an ACTIVATE ACK or DEACTIVATE ACK PDU shall be sent to the requesting entity with the activation/deactivation result.

6.5.3.4 Definition procedure

When FE2 receives a DEFINE PDU from FE3 or FE7, FE2 shall check that the user is authorized to make the definition by calling Define_CAD before the SS-CAD restrictions are set for the TETRA addresses specified. The result of the definition procedure shall then be sent back to the requesting entity in a DEFINE ACK PDU.

6.5.3.5 Interrogation procedure

When FE2 receives an INTERROGATION PDU from FE2 or FE7, FE2 shall check that the requesting user is authorized to interrogate by calling Interrogate_CAD before the SS-CAD restrictions for a certain restricted user are sent back in an INTERROGATE ACK PDU.

6.5.4 Procedures for FE3

FE3 is the authorized user's agent in the MS/LS. As an implementation option, concurrent operation of FE3 functions can be possible through multiple independent state machines. The allocation/deallocation of multiple FE3 state machines is outside the scope of this ETS.

FE3 receives requests from the application for activation, deactivation, definition or interrogation, and sends the appropriate PDU to FE2. On receipt of an acknowledgement PDU from FE2 to a request, it sends the appropriate indication to the Application. These requests are not confirmed by SS-CAD and it is the responsibility of the Application to match up indications to requests sent.

6.5.5 Procedures for FE7

FE7 is the dispatcher agent in the MS/LS. As an implementation option, concurrent operation of FE7 functions can be possible through multiple independent state machines. The allocation/deallocation of multiple FE7 state machines is outside the scope of this ETS.

6.5.5.1 Normal operation of FE7

When a REQUEST PDU is received from the SS-CAD intercepting FE2, a REQUEST_indication primitive shall be sent to the dispatcher application. FE2 also calls Store_diversion_state using the Interception Type element to store which calls have been diverted to the dispatcher. It is the responsibility of the Application to ensure response primitives match received REQUEST_indications.

When the dispatcher is in another SwMI than the SS-CAD intercepting SwMI and there is not a call related signalling connection available then the ACCEPT, DIVERT and REJECT PDUs shall be sent using ANF-ISISS and the REQUEST PDU will be received by ANF-ISISS as defined in ETS 300 392-9 [6]. The FE7 shall send the ACCEPT, DIVERT and REJECT PDUs to the SS-CAD intercepting SwMI using routing information from the REQUEST PDU as defined in ETS 300 392-9 [6]. When the ACCEPT or INTERCEPTED PDU is to be sent over ISI and there is not yet a signalling connection available then it shall be sent in a PSS1 PROGRESS message.

6.5.5.2 Calling user A disconnects during interception

If a CANCEL PDU is received from the SS-CAD intercepting FE2 during the interception, FE7 shall send a CANCEL_indication primitive to the application, which should remove the reference to the related interception request.

6.5.5.3 Activation/deactivation/definition/interrogation requests from the dispatcher

FE7 follows the same procedures as FE3 detailed in subclauses 6.3.3.3, 6.3.3.4 and 6.3.3.5 to handle these requests.

History

Document history			
July 1996	Public Enquiry	PE 110:	1996-07-22 to 1996-11-15
August 1998	Vote	V 9841:	1998-08-11 to 1998-10-09