

**E**UROPEAN  
**T**ELECOMMUNICATION  
**S**TANDARD

**DRAFT**  
pr **ETS 300 392-11-24**  
December 1999

---

Source: TETRA

Reference: DE/TETRA-03001-11-24

ICS: 33.020

**Key words:** TETRA, data, radio, retention, speech, Stage 2, supplementary service, V + D

**Terrestrial Trunked Radio (TETRA);  
Voice plus Data (V+D);  
Part 11: Supplementary services stage 2;  
Sub-part 24: Call Retention (CRT)**

**ETSI**

European Telecommunications Standards Institute

**ETSI Secretariat**

**Postal address:** F-06921 Sophia Antipolis CEDEX - FRANCE

**Office address:** 650 Route des Lucioles - Sophia Antipolis - Valbonne - FRANCE

**Internet:** [secretariat@etsi.fr](mailto:secretariat@etsi.fr) - <http://www.etsi.org>

Tel.: +33 4 92 94 42 00 - Fax: +33 4 93 65 47 16

---

**Copyright Notification:** No part may be reproduced except as authorized by written permission. The copyright and the foregoing restriction extend to reproduction in all media.

© European Telecommunications Standards Institute 1999. All rights reserved.



## Contents

Foreword .....		5
1	Scope .....	7
2	Normative references .....	7
3	Definitions, symbols and abbreviations.....	7
3.1	Definitions.....	7
3.2	Symbols.....	8
3.3	Abbreviations.....	8
3.3.1	General abbreviations .....	8
3.3.2	Supplementary service abbreviations .....	9
4	SS-CRT stage 2 specification.....	9
4.1	Functional model.....	9
4.1.1	Description .....	9
4.1.1.1	Individual Call .....	10
4.1.1.2	Group Call .....	10
4.1.2	Description of Functional Entities.....	11
4.1.2.1	Case of Individual call .....	11
4.1.2.1.1	Calling user agent, FE1 .....	11
4.1.2.1.2	Calling user's control entity, FE21 .....	11
4.1.2.1.3	Transit entity, FE23 .....	11
4.1.2.1.4	Called user's control entity, FE25.....	11
4.1.2.1.5	Called user agent, FE5.....	12
4.1.2.2	Case of group call .....	12
4.1.2.2.1	Calling user agent, FE1 .....	12
4.1.2.2.2	Calling user's control entity, FE21 .....	12
4.1.2.2.3	Called group control entity, FE22 .....	12
4.1.2.2.4	Transit entity, FE23 .....	12
4.1.3	Relationship of functional model to basic call functional model.....	13
4.1.3.1	Individual call.....	13
4.1.3.2	Group call .....	13
4.1.4	Service primitives.....	13
4.2	Information flows .....	13
4.2.1	Definition of information flows .....	13
4.2.1.1	CRT-B .....	13
4.2.1.2	CRT-F .....	14
4.2.1.3	ISI-CRT-B.....	14
4.2.1.4	ISI-CRT-F.....	14
4.2.2	Relationship of information flows to basic call information flows .....	15
4.2.3	Information flow sequences .....	15
4.2.3.1	Individual call.....	15
4.2.3.1.1	Normal operation, forward direction .....	15
4.2.3.1.2	Normal operation, both directions .....	17
4.2.3.1.3	Normal operation, backward direction..	18
4.2.3.1.4	Normal operation, both directions, invocation of SS-CRT during established call.....	19
4.2.3.2	Group call .....	20
4.2.3.2.1	Normal operation, forward direction .....	20
4.2.3.2.2	Normal operation, both directions .....	21
4.2.3.2.3	Normal operation, backward direction..	22
4.2.3.2.4	Normal operation, forward direction once call is established.....	23
4.3	Functional Entity actions.....	24
4.3.1	Actions of FE1.....	24

4.3.2	Actions of FE21 .....	24
4.3.3	Actions of FE23 .....	24
4.3.4	Actions of FE22 .....	24
4.3.5	Actions of FE25 .....	24
4.3.6	Actions of FE5 .....	25
4.4	Allocation of Functional Entities to physical equipment .....	25
4.5	Inter-working considerations .....	25
History .....		26

## Foreword

This draft European Telecommunication Standard (ETS) has been produced by the Terrestrial Trunked Radio ETSI Project of the European Telecommunications Standards Institute (ETSI), and is now submitted for the Public Enquiry phase of the ETSI standards approval procedure.

This ETS is a multi-part standard and will consist of the following parts:

- Part 1: "General network design";
- Part 2: "Air Interface (AI)";
- Part 3: "Interworking at the Inter-System Interface (ISI)";
- Part 4: "Gateways basic operation";
- Part 5: "Peripheral Equipment Interface (PEI)";
- Part 6: "Line connected Station (LS)";
- Part 7: "Security";
- Part 9: "General requirements for supplementary services";
- Part 10: "Supplementary services stage 1";
- Part 11: "Supplementary services stage 2";**
- Part 12: "Supplementary services stage 3";
- Part 13: "SDL model of the Air Interface (AI)";
- Part 14: "Protocol Implementation Conformance Statement (PICS) proforma specification".

<b>Proposed transposition dates</b>	
Date of latest announcement of this ETS (doa):	3 months after ETSI publication
Date of latest publication of new National Standard or endorsement of this ETS (dop/e):	6 months after doa
Date of withdrawal of any conflicting National Standard (dow):	6 months after doa

Blank page

## 1 Scope

This draft ETS specifies the supplementary service Call Retention which is applicable to various basic services supported by TETRA SwMIs. Basic services are specified in ETS 300 392-2 [4].

SS-CRT is a supplementary service which applies either during call establishment or once call is established to protect a call from pre-emption by another call of lower priority.

Supplementary service specifications are produced in three stages, according to the method described in ITU-T Recommendation I.210 [2]. The present document contains the stage 2 specifications of SS-CRT. The stage 2 descriptions specify the supplementary services functional entities, their relations and the information flows needed to support the supplementary service.

This draft ETS is applicable to circuit mode TETRA V+D tele-services and bearer services. This draft ETS is not applicable to TETRA Short Data Service (SDS).

Man Machine Interfaces and charging principles are outside the scope of this draft ETS.

The first edition of this ETS is based on the latest edition of ECMA-263 [1]. Additions to ECMA-263 [1] have been made to take into account particular TETRA specifics such as group calls and to include requirements and situations not addressed in ECMA-263 [1].

## 2 Normative references

This draft ETS incorporates by dated and undated reference, provisions from other publications. These normative references are cited at the appropriate places in the text and the publications are listed hereafter. For dated references, subsequent amendments to or revisions of any of these publications apply to this draft ETS only when incorporated in it by amendment or revision. For undated references the latest edition of the publication referred to applies.

- [1] ECMA-263 (1997): "Private Integrated Services Network (PISN) - Specification, Functional Model and Information Flows - Call Priority Interruption and Call Priority Interruption Protection Supplementary Services (CPI(P)SD)".
- [2] ITU-T Recommendation I.210 (1993): "Principles of telecommunication services supported by an ISDN and the means to describe them".
- [3] ITU-T Recommendation Z.100 (1993): "CCITT Specification and description language (SDL)".
- [4] ETS 300 392-2 (1995): "Terrestrial European Trunked Radio (TETRA); Voice plus Data (V+D); Part 2: Air Interface (AI)".
- [5] ETS 300 392-10-24 (1996): "Trans-European Trunked Radio (TETRA); Voice plus Data (V+D); Part 10: Supplementary services stage 1; Part 10-24: Call retention".
- [6] ETS 300 392-12-24 (1999): "Trans-European Trunked Radio (TETRA); Voice plus Data (V+D); Part 12: Supplementary services stage 3; Part 12-24: Call retention".

## 3 Definitions, symbols and abbreviations

### 3.1 Definitions

For the purposes of this ETS, the following definitions apply:

**Call Priority Interruption Capability Level (CPICL):** parameter indicating the priority of a call. (ECMA-263) to be used in case of inter-working

**Call Priority Interruption Protection Level (CPIPL):** parameter indicating a level of protection of a call against interruption from other calls. (ECMA-263) to be used in case of inter-working

**Call Retention Value (CRV):** value which defines the relative level of protection of established calls against pre-emption

**Call Retention Backward (CRV-B):** call Retention Value in the Backward direction (connect)

**Call Retention Forward (CRV-F):** call Retention Value in the Forward direction (set-up)

**established call:** active call that is selected for interruption

**impending priority interruption state:** condition of an established call and a priority call after provision of an Impending priority interruption warning notification and before the release of the established call (SS-PPC)

**impending priority interruption warning notification:** notification provided before the release of the established call. (SS-PPC)

**non-priority call:** call that has not been assigned a call priority value

**priority call:** call that has a call priority value greater than zero

NOTE 1: A priority call may also be a protected call.

**protected call:** call that has a CRV value greater than zero

NOTE 2: A protected call may also be a priority call.

**served user:** user who requests SS-CRT

**Switching and Management Infrastructure (SwMI):** all of the TETRA equipment for a Voice plus Data (V+D) network except for subscriber terminals. The SwMI enables subscriber terminals to communicate with each other via the SwMI

**time to priority interruption:** duration of the impending priority interruption state.(SS-PPC)

**unprotected call:** call which has not been assigned a CRV value or has a CRV value equal to zero

## 3.2 Symbols

For the purposes of this ETS, there are no additional symbols excepted the symbols used in the SDL representation (ITU T Recommendation Z.100 [3]).

## 3.3 Abbreviations

### 3.3.1 General abbreviations

For the purposes of this ETS, the following general abbreviations apply:

CRT	Call Retention
CRV	Call Retention Value
CRV-B	CRV Backward
CRV-F	CRV Forward
FE	Functional Entity
GTSI	Group TETRA Subscriber Identity
ISDN	Integrated Services Digital Network
ISI	Inter System Interface
ISI-CRT	Inter System Interface Call Retention
ISI-CRT-B	Inter System Interface Call Retention Backward
ISI-CRT-F	Inter System Interface Call Retention Forward
ISI-CRV-B	Inter System Interface Call Retention Value Backward



ISI-CRV-F	Inter System Interface Call Retention Value Forward
ITSI	Individual TETRA Subscriber Identity
SDL	(Functional) Specification and Description Language
SS	Supplementary Service

NOTE: The abbreviation SS is only used when referring to a specific supplementary service.

SwMI	Switching and Management Infrastructure
TETRA	Trans-European Trunked RAdio

### 3.3.2 Supplementary service abbreviations

For the purposes of this ETS, the following Supplementary Service abbreviations apply:

AL	Ambience Listening
AoC	Advice of Charge
AP	Access Priority
AS	Area Selection
BIC	Barring of Incoming Calls
BOC	Barring of Outgoing Calls
CAD	Call Authorized by Dispatcher
CCBS	Call Completion to Busy Subscriber
CCNR	Call Completion on No Reply
CFB	Call Forwarding on Busy
CFNRy	Call Forwarding on No Reply
CFNRc	Call Forwarding on Not Reachable
CFU	Call Forwarding Unconditional
CLIP	Calling Line Identification Presentation
CLIR	Calling/Connected Line Identification Restriction
COLP	Connected Line Identification Presentation
CR	Call Report
CRT	Call Retention
CRV	Call Retention Value
CW	Call Waiting
DGNA	Dynamic Group Number Assignment
DL	Discreet Listening
HOLD	Call Hold
IC	Include Call
LE	Late Entry
LSC	List Search Call
PC	Priority Call
PPC	Pre-emptive Priority Call
SNA	Short Number Addressing
TC	Transfer of Control
TPI	Talking Party Identification

## 4 SS-CRT stage 2 specification

### 4.1 Functional model

#### 4.1.1 Description

NOTE: There is no authorized user/management functional model for SS-CRT according to ETS 300 392-10-24 [5].

4.1.1.1 Individual Call

The functional model shall comprise the following functional entities for individual call:

- FE1 Calling user agent;
- FE21 Calling user's control entity;
- FE23 SS-CRT Transit Entity;
- FE25 Called user's control entity;
- FE5 Called user agent.

The following functional relationships shall exist between these FEs:

- ra between FE1 and FE21;
- rb between FE21 and FE25, between FE21 and FE23, between FE23s and between FE23 and FE25;
- rc between FE25 and FE5.

Figure 1 shows these FEs and relationships.

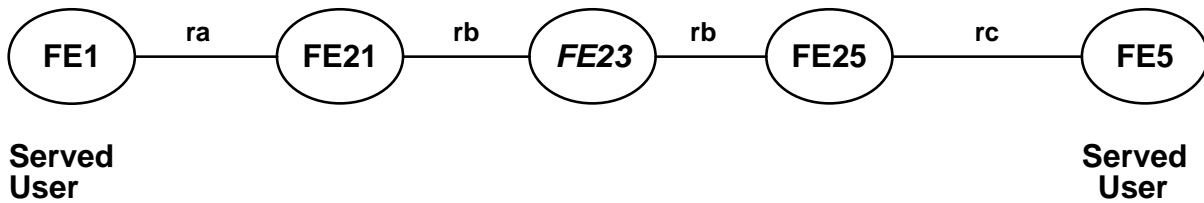

NOTE: Functional entities shown in italic may be absent or may repeat as needed.

Figure 1: Functional model for SS-CRT case of individual call

4.1.1.2 Group Call

The functional model shall comprise the following Functional Entities (FE) for group call:

- FE1 Calling user agent;
- FE21 Calling user's control entity;
- FE22 Called group control entity;
- FE23 SS-CRT Transit Entity.

The following functional relationships shall exist between these FEs:

- ra between FE1 and FE21;
- rb between FE21 and FE22, between FE21 and FE23, between FE23s and between FE23 and FE22.

Figure 2 shows these FEs and relationships.

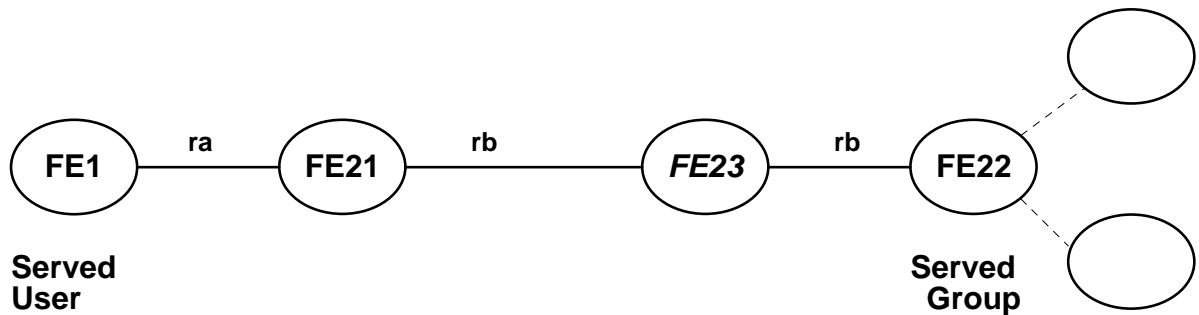

NOTE 1: Functional entities shown in italic may be absent or may repeat as needed.

NOTE 2: Group members are not shown.

**Figure 2: Functional model for SS-CRT case of group call**

#### 4.1.2 Description of Functional Entities

##### 4.1.2.1 Case of Individual call

###### 4.1.2.1.1 Calling user agent, FE1

This functional entity receives protection requests from the calling user and passes these on to FE21.

###### 4.1.2.1.2 Calling user's control entity, FE21

This functional entity:

- receives and validates requests from FE1 for forward invocation of SS-CRT;
- if SS-CRT is applicable for the call, sends an invocation request ("forward invocation request") to either FE23 or FE25 at the time of the original basic call U\_SETUP;
- receives backward invocation requests from either FE23 or FE25;
- saves the protection level for the call.

###### 4.1.2.1.3 Transit entity, FE23

This functional entity:

- on an incoming call with an SS-CRT request sends a forward invocation request either to the next FE23 or to FE25 either at the time of the original basic call ISI\_GC\_SETUP or once the group call is established;
- receives backward invocation requests from either FE25 or a subsequent FE23, and passes them on either to FE21, or to a preceding FE23;
- saves the protection level for the call.

###### 4.1.2.1.4 Called user's control entity, FE25

This functional entity:

- receives forward invocation requests from either FE21 or FE23;
- receives and validates requests from FE5 for invocation of SS-CRT in the backward direction;

- if SS-CRT is applicable in the backward direction (i.e., if the protection level requested by the called user is higher than that requested by the calling user), sends an invocation request ("backward invocation request") to FE21 at the time of the U\_CONNECT information flows;
- saves the protection level for the call.

#### **4.1.2.1.5 Called user agent, FE5**

This functional entity receives protection requests from the called user and passes these on to FE25.

#### **4.1.2.2 Case of group call**

##### **4.1.2.2.1 Calling user agent, FE1**

This functional entity receives protection requests from the calling user and passes these on to FE21.

##### **4.1.2.2.2 Calling user's control entity, FE21**

This functional entity receives and validates requests from FE1 for forward invocation of SS-CRT;

- if SS-CRT is applicable for the call, sends an invocation request ("forward invocation request") to either FE22 or FE23 at the time of the original basic call U\_SETUP;
- receives backward invocation requests from either FE22 or FE23;
- saves the protection level for the call.

##### **4.1.2.2.3 Called group control entity, FE22**

This functional entity:

- receives forward invocation requests from FE21;
- checks and validates default (pre-assigned) values of CRVs for invocation of SS-CRT in the backward direction;
- if SS-CRT is applicable in the backward direction (i.e., if the protection level stored by the called group functional entity FE22 is higher than that requested by the calling user), sends an invocation request ("backward invocation request") to FE21 at the time of the ISI\_GC-SETUP information flows;
- saves the protection level for the call.

##### **4.1.2.2.4 Transit entity, FE23**

This functional entity:

- on an incoming call with a SS-CRT request sends a forward invocation request either to the next FE23 or to FE22 at the time either of the original basic group call ISI\_GC\_SETUP or once the group call is setup;
- receives backward invocation requests from either FE22 or a subsequent FE23, and passes them on either to FE21 or to a preceding FE23;
- saves the protection level for the call.

### 4.1.3 Relationship of functional model to basic call functional model

#### 4.1.3.1 Individual call

An example of a relationship between the FEs for SS-CRT and the FEs for the basic individual call is shown in figure 3.

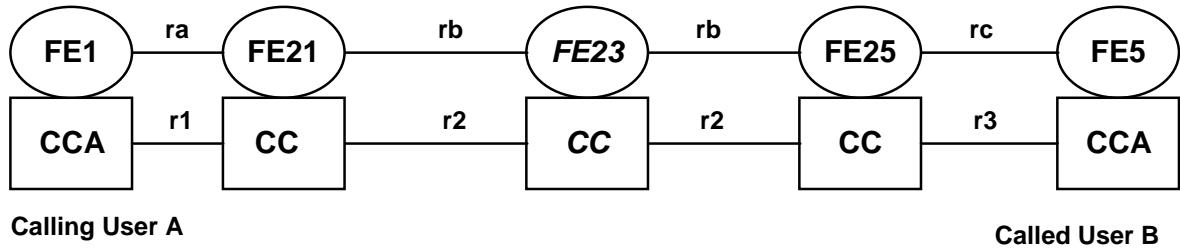

NOTE: Functional entities shown in italic may be absent or may repeat as needed.

Figure 3: Example relationship between the model for SS-CRT and basic call

#### 4.1.3.2 Group call

An example of a relationship between the FEs for SS-CRT and the FEs for the basic group call is shown in figure 4.

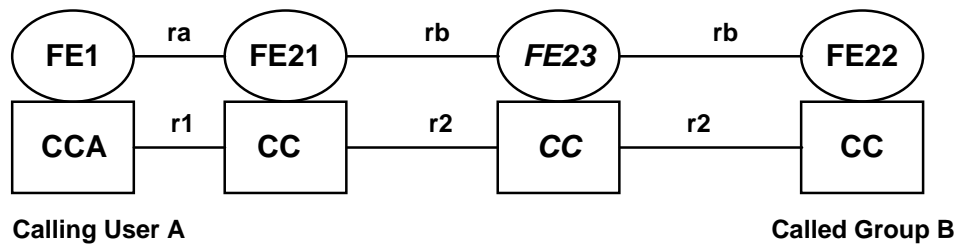

NOTE: Functional entities shown in italic may be absent or may repeat as needed.

Figure 4: Example relationship between the model for SS-CRT and basic call

#### 4.1.4 Service primitives

This subclause lists SS-CRT service primitives used to invoke SS-CRT. The SS-CRT service primitives are defined in ETS 300 392-12-24 [6], subclause 4.2 and the basic call service primitives are defined in ETS 300 392-2 [4], clause 11.

The SS-CRT service primitives for any of the two served user at the MS/LS TNSS-SAP shall be:

- CRT-B request;
- CRT-F request.

### 4.2 Information flows

#### 4.2.1 Definition of information flows

In the tables listing the elements in information flows, the column headed "Request" indicates which of these elements are mandatory (M) and which are optional (O) in a request/indication information.

##### 4.2.1.1 CRT-B

CRT-B is an unconfirmed information flow sent across rc from FE5 to FE25. It is used to invoke protection in the backward direction.

Table 1 lists the elements within the CRT-B information flow.

**Table 1: Content of CRT-B**

Element	Request
CRV-B	O Note
NOTE:	Between FE5 and FE25 this element may be omitted in the case that the called user does not have the capability to change or select CRV. This element shall have a value in the range 0 (no protection) to 3 (total protection).

**4.2.1.2 CRT-F**

CRT-F is an unconfirmed information flow sent across ra from FE1 to FE21. It is used to invoke protection in the forward direction.

Table 2 lists the elements within the CRT-F information flow.

**Table 2: Content of CRT-F**

Element	Request
CRV-F	O Note
NOTE:	Between FE1 and FE21 this element may be omitted in the case that the calling user does not have the capability to change or select CRV. This element shall have a value in the range 0 (no protection) to 3 (total protection).

**4.2.1.3 ISI-CRT-B**

ISI-CRT-B is an unconfirmed information flow sent across rb either from FE25 to FE21, from FE25 to FE23, between FE23s or from FE23 to FE21 in the case of an individual call; ISI-CRT-B is an unconfirmed information flow sent across rb either from FE22 to FE23, between FE23s, from FE23 to FE21 or from FE22 to FE21 in the case of a group call. It is used to invoke protection in the backward direction.

Table 3 lists the elements within the ISI-CRT-B information flow.

**Table 3: Content of ISI-CRT-B**

Element	Request
ISI-CRV-B	M Note
NOTE:	This element shall have a value in the range 0 (no protection) to 3 (total protection).

**4.2.1.4 ISI-CRT-F**

ISI-CRT-F is an unconfirmed information flow sent across rb from either FE21 to FE25, FE21 to FE23, between FE23s or between FE23 and FE25 in the case of an individual call; ISI-CRT-F is an unconfirmed information flow sent across rb from either FE21 to FE22, FE21 to FE23, between FE23s or from FE23 to FE22 in the case of a group call. It is used to invoke protection in the forward direction.

Table 4 lists the elements within the ISI-CRT-F information flow.

**Table 4: Content of ISI-CRT-F**

Element	Request
ISI-CRV-F	M Note
NOTE: This element shall have a value in the range 0 (no protection) to 3 (total protection).	

#### 4.2.2 Relationship of information flows to basic call information flows

Table 5 summarizes the relationships of the SS-CRT information flows with those of the basic call.

**Table 5: Relationship of the SS-CRT information flows with the basic call**

Information flow			Independent of basic call flow	With basic call flow	Basic call flows
ra	CRT-F	request	no	yes	U_SETUP req/ind Note 3
rb	ISI-CRT-F	request	no	yes	ISI_SETUP req/ind Note 3
	ISI-CRT-B	request	no	yes	ISI_CONNECT resp/conf Note 3
rc	CRT-B	request	no	yes	D_SETUP resp/conf Notes 1, 3
ra	CRT-F	request	yes	no	Notes 2, 4
rb	ISI-CRT-F	request	yes	no	Notes 2, 4
	ISI-CRT-B	request	yes	no	Notes 2, 4
rc	CRT-B	request	yes	no	Note 4
NOTE 1: Excepted in the case of group call.					
NOTE 2: In the case where a user changes the CRV during a call; call related but not with basic call flow.					
NOTE 3: SS-CRT is invoked at call setup time.					
NOTE 4: SS-CRT is invoked once the call is established.					

#### 4.2.3 Information flow sequences

A stage 3 standard for SS-CRT shall provide signaling procedures in support of the information flow sequences specified below. In addition, signaling procedures should be provided to cover other sequences arising from error situations, interactions with basic call, interactions with other supplementary services, different topologies, etc.

In the figures, SS-CRT information flows are represented by solid arrows and basic call information flows are represented by broken arrows. An ellipse embracing two information flows indicates that the two information flows occur simultaneously. Within a column representing a SS-CRT functional entity, the numbers refer to functional entity actions listed in subclause 4.3.

The following abbreviations are used:

- req request;
- ind indication.

##### 4.2.3.1 Individual call

##### 4.2.3.1.1 Normal operation, forward direction

Figure 5 shows the information flow sequence for a successful protection attempt invoked in the forward direction.

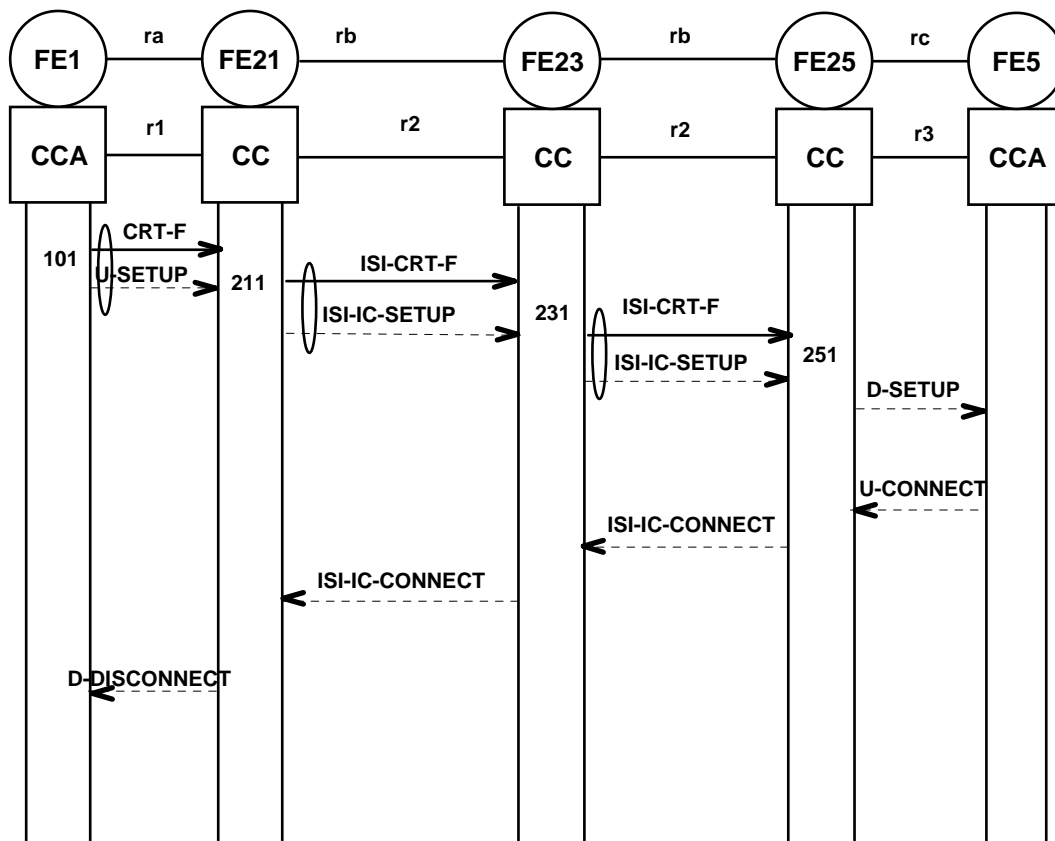

Figure 5: Information flow sequence for SS-CRT normal operation, forward direction, individual call



4.2.3.1.2 Normal operation, both directions

Figure 6 shows the information flow sequence for a successful protection attempt invoked in both directions.

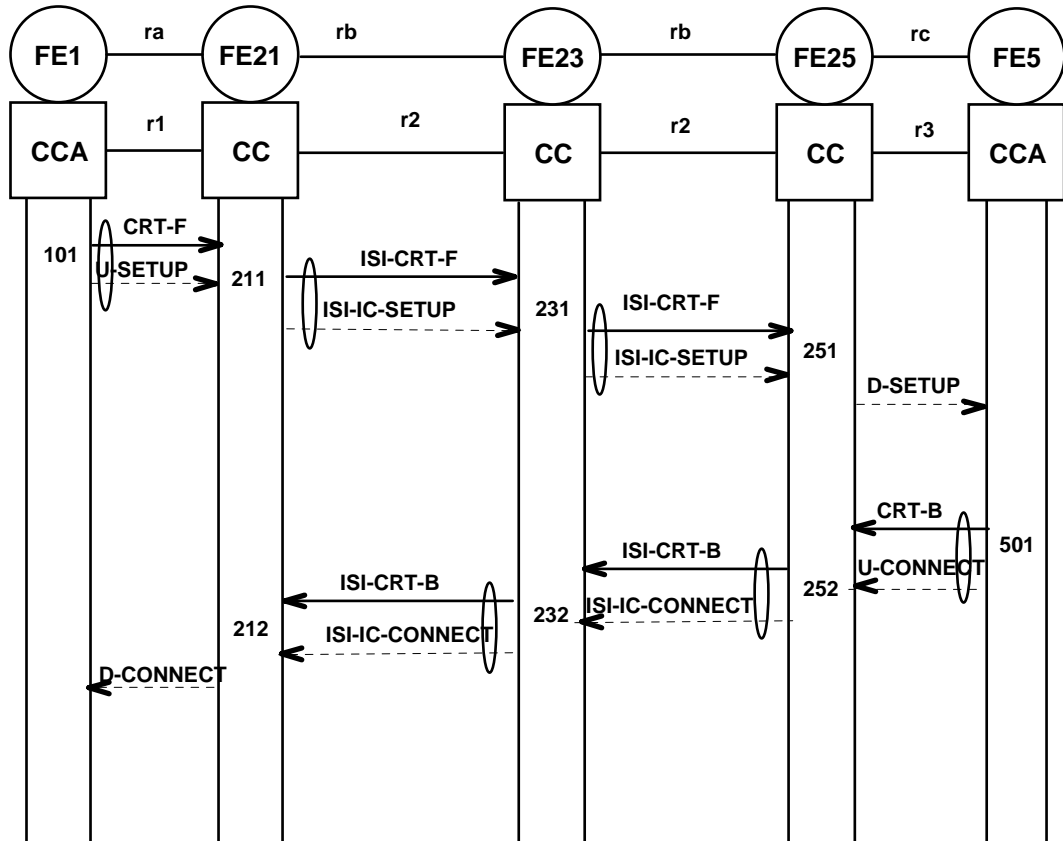

Figure 6: Information flow sequence for SS-CRT - normal operation, both directions

4.2.3.1.3 Normal operation, backward direction

Figure 7 shows the information flow sequence for a successful protection attempt invoked in the backward direction.

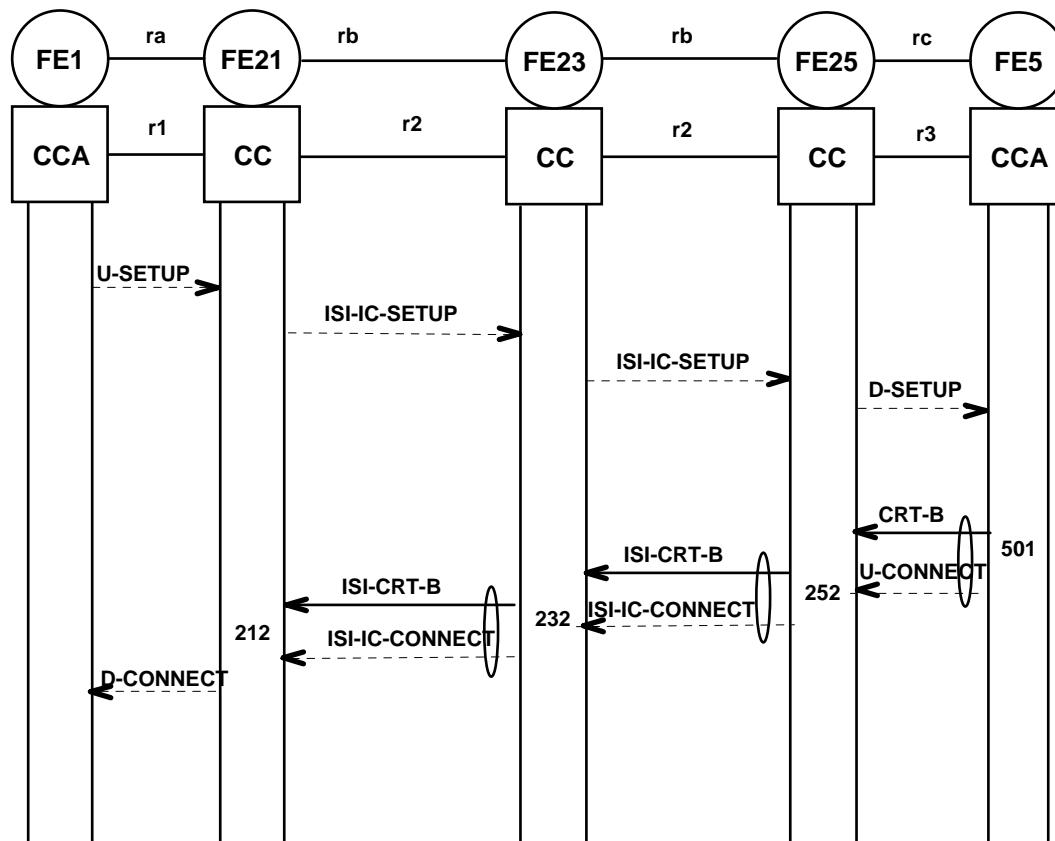

Figure 7: Information flow sequence for SS-CRT - normal operation, backward direction

4.2.3.1.4 Normal operation, both directions, invocation of SS-CRT during established call

Figure 8 shows the information flow sequence for a successful protection attempt invoked in both directions.

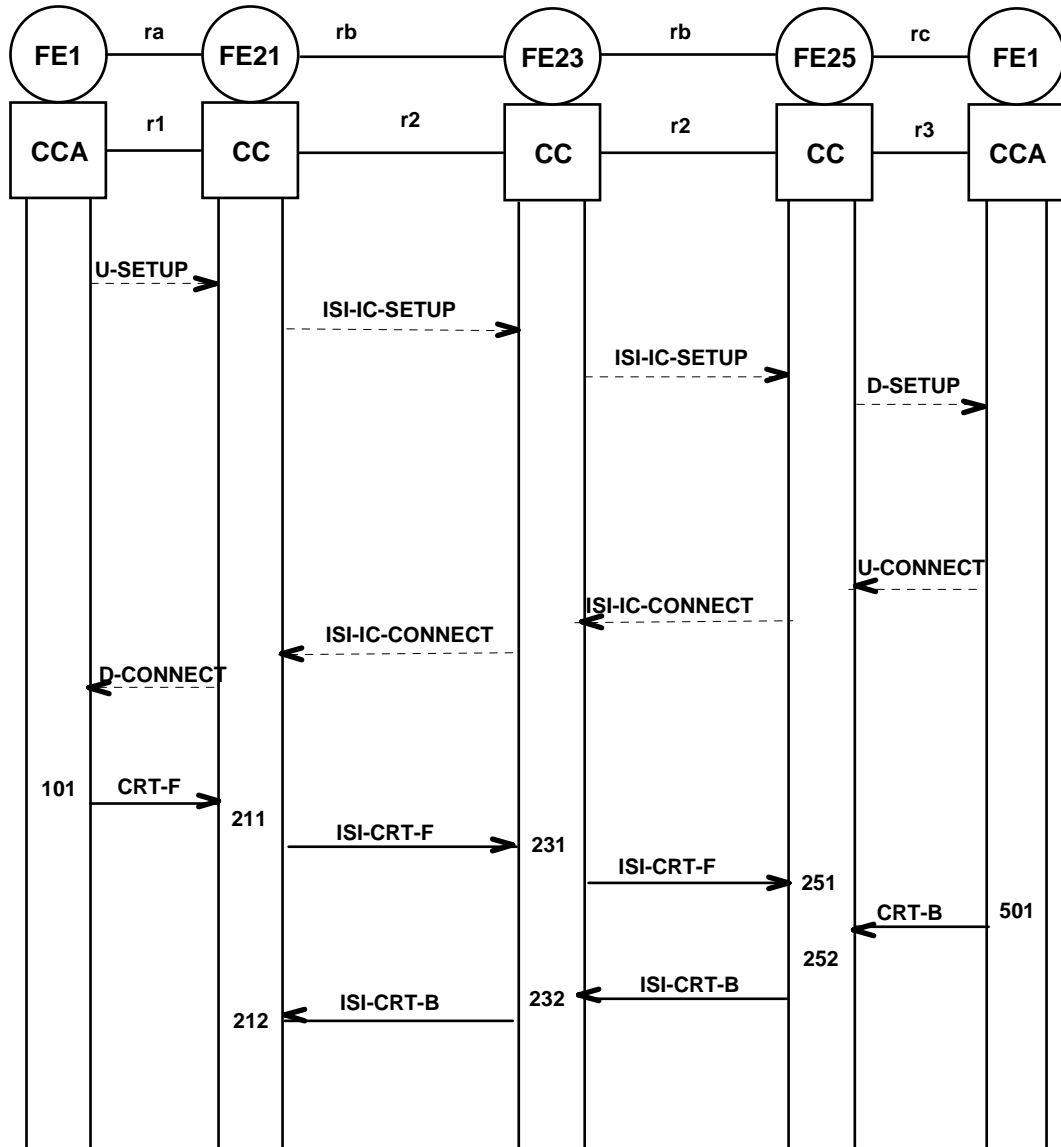

Figure 8: Information flow sequence for SS-CRT - normal operation, both directions

4.2.3.2 Group call

4.2.3.2.1 Normal operation, forward direction

Figure 9 shows the information flow sequence for a successful protection attempt invoked in the forward direction.

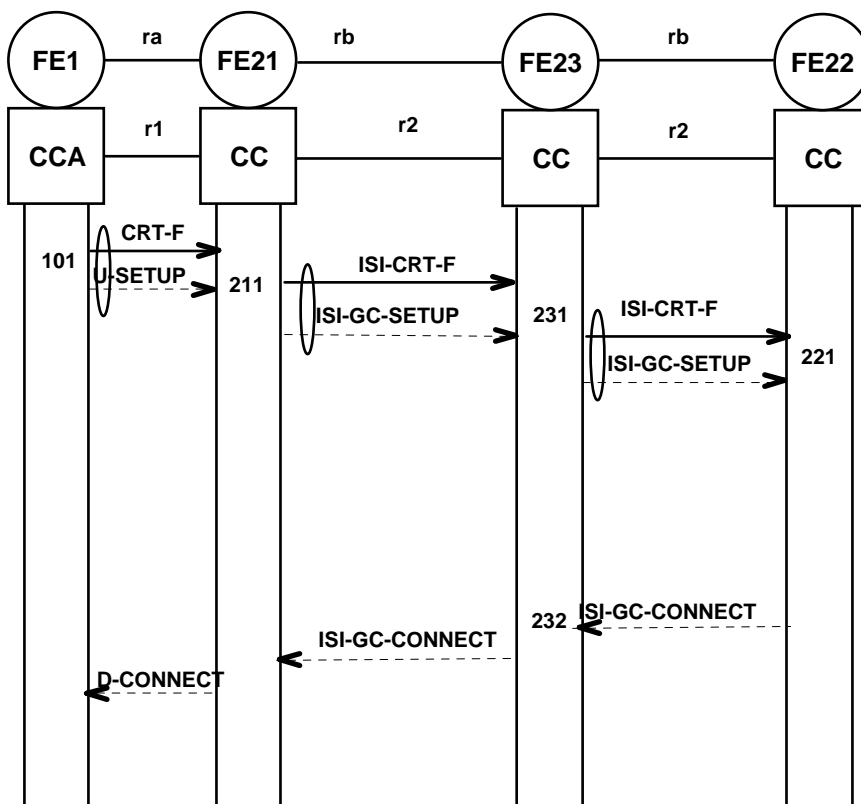

Figure 9: Information flow sequence for SS-CRT - normal operation, forward direction, group call

4.2.3.2.2 Normal operation, both directions

Figure 10 shows the information flow sequence for a successful protection attempt invoked in both directions.

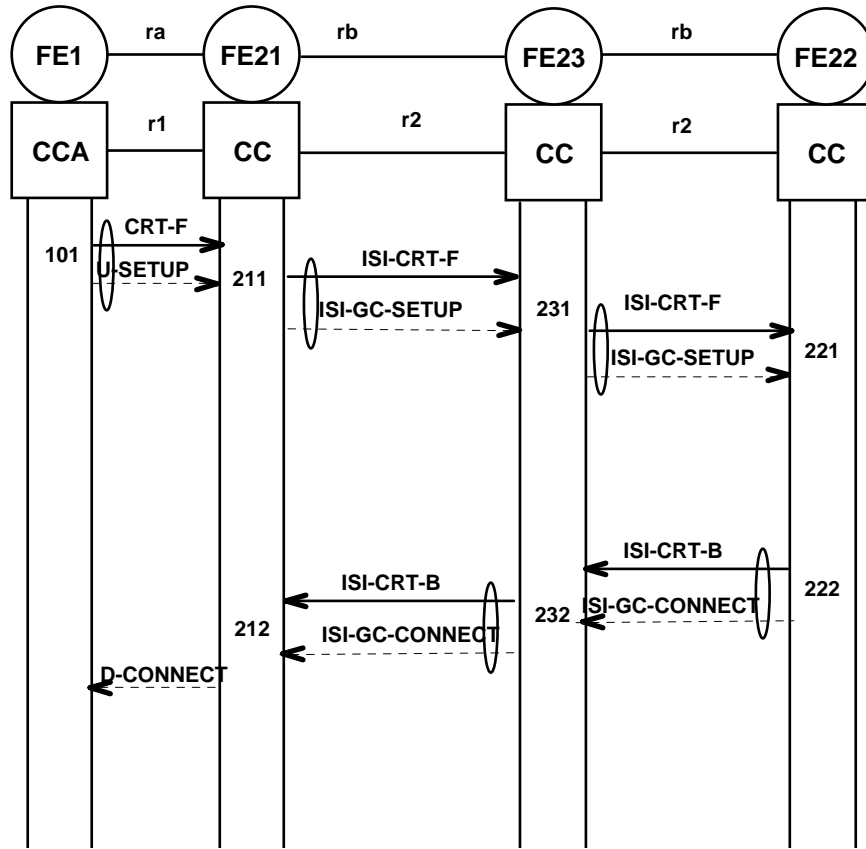

Figure 10: Information flow sequence for SS-CRT - normal operation, both directions, group call

4.2.3.2.3 Normal operation, backward direction

Figure 11 shows the information flow sequence for a successful protection attempt invoked in the backward direction.

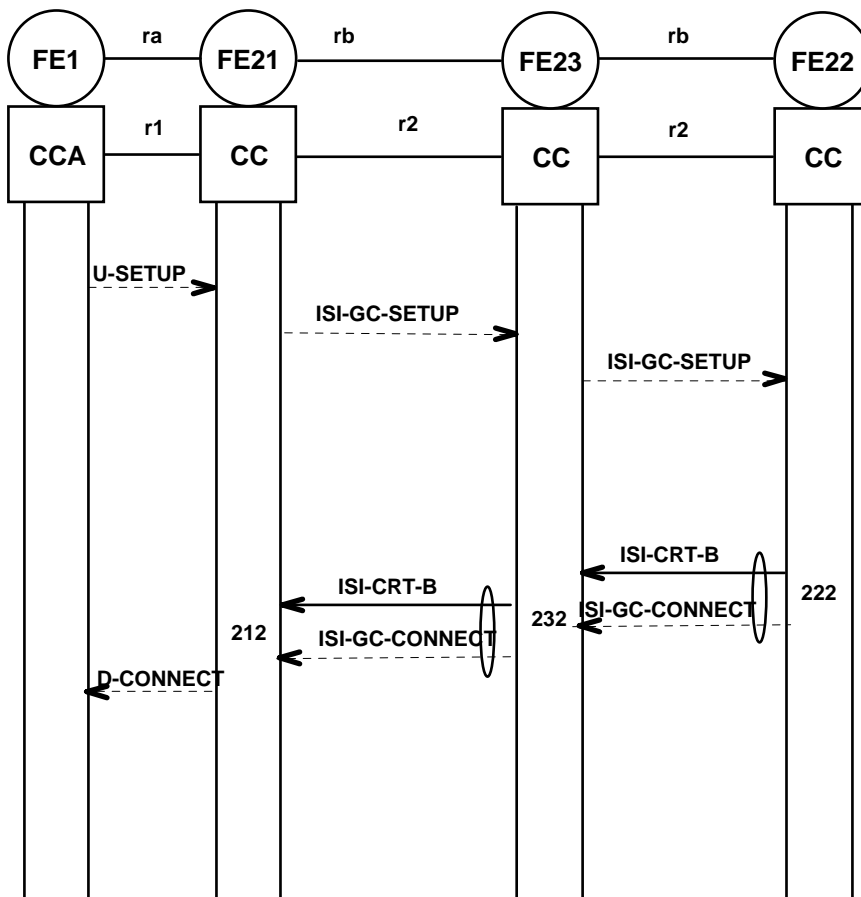

Figure 11: Information flow sequence for SS-CRT - normal operation, backward direction, group call

4.2.3.2.4 Normal operation, forward direction once call is established

Figure 12 shows the information flow sequence for a successful protection attempt invoked in the forward direction.

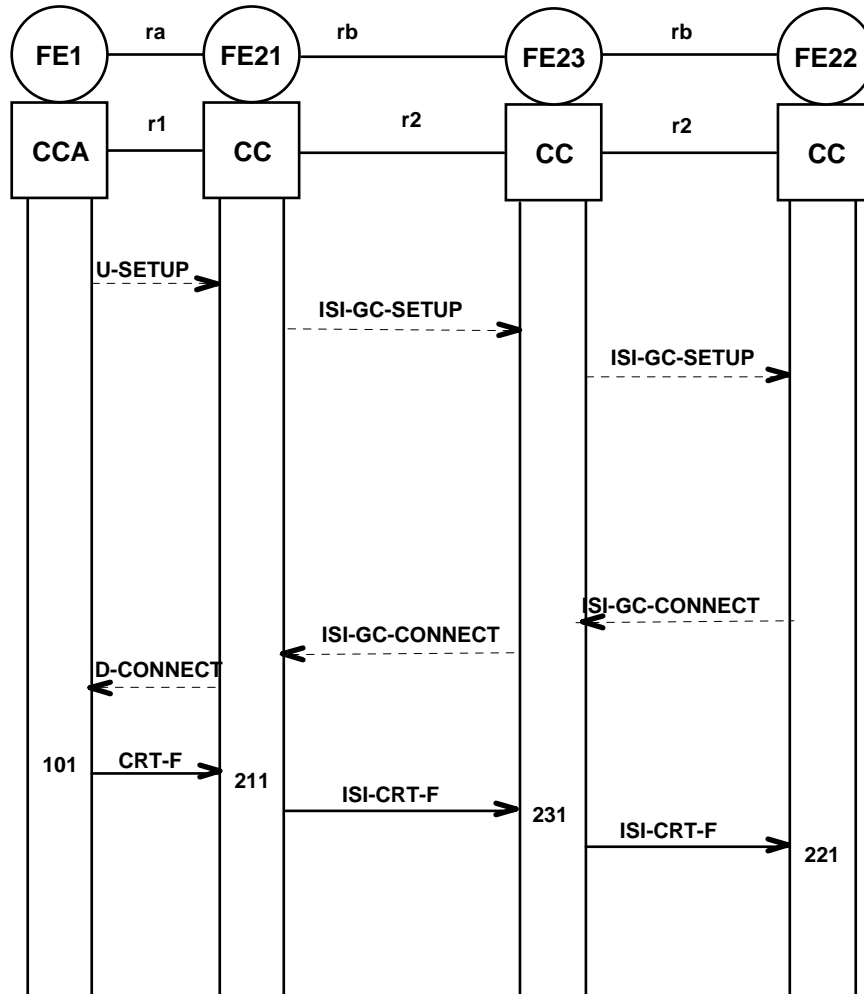

Figure 12: Information flow sequence for SS-CRT - normal operation, forward direction once group call is established.

NOTE: It is assumed that a group SwMI cannot invoke SS-CRT once group call is established; thus the corresponding information flows (backward and both directions) do not exist.

### 4.3 Functional Entity actions

The following FE actions shall occur at the points indicated in the figures of subclause 5.2.

#### 4.3.1 Actions of FE1

101: The FE shall receive the user's request for call protection and send a CRT-F req/ind to FE21, optionally including CRV.

#### 4.3.2 Actions of FE21

211: FE21 shall receive the CRT-F req/ind information flow from FE1 and check whether the user is provided with the forward invocation procedure of SS-CRT. If provided, the FE shall send a ISI-CRT-F req/ind information flow including a CRV-F to FE25 or FE23. If a CRV has been included in the CRT-F req/ind information flow received from FE1, the corresponding ISI-CRV-F shall be included in the ISI-CRT-F req/ind information flow sent to FE25 or FE23. FE21 shall save the protection level of the call. If the user is not provided with the forward invocation procedure of SS-CRT, the FE shall ignore the CRT-F req/ind information flow received from FE1. In the case where FE1 requests a value outside its allowed range, FE21 shall assign the closest value within the allowed range. In the case where two values CRV-F and CRV-F have been requested for the same call, FE21 shall compare the two values and allocate the highest of the two values to the call protection.

212: FE21 shall receive the ISI-CRT-B req/ind information flow from FE25 or FE23. FE21 shall save the value of the ISI-CRV-B included in the ISI-CRT-B req/ind information flow as the protection level for the duration of the call as well as converting that ISI-CRV-B into a local CRV-B value for storage and protection of that call locally.

#### 4.3.3 Actions of FE23

231: FE23 shall receive the ISI-CRT-F req/ind information flow from FE21 or from a previous FE23, and shall store the ISI-CRV-F value as the protection level for the duration of the call. FE23 shall send a ISI-CRT-F req/ind information flow including the received ISI-CRV-F to the next FE23 (if there is one) or to FE25.

232: FE23 shall receive the ISI-CRT-B req/ind information flow from FE25 or from a previous FE23. FE23 shall save the value of the ISI-CRV-B included in the ISI-CRT-B req/ind information flow as the protection level for the duration of the call.

FE23 shall send a ISI-CRT-B req/ind information flow including the received ISI-CRV-B to the next FE23 (if there is one) or to FE21.

#### 4.3.4 Actions of FE22

221: FE22 shall receive the ISI-CRT-F req/ind information flow from FE21 or from a previous FE23, and shall store the CRV value as the protection level for the duration of the call.

222: FE22 shall use the pre-set CRV and shall check whether the group is provided with the backward invocation procedure of SS-CRT. If the backward invocation procedure is provided for that group, and if the CRV-B has a higher value than that already saved for the call (CRV-F), the FE shall save this value as the protection level for the duration of the call.

FE22 shall send an ISI-CRT-B req/ind information flow including an ISI-CRV-B to FE23 or FE21. The assigned CRV to that group call shall be included in the ISI-CRT-B req/ind information flow sent to FE23 or FE21. If the group is not provided with the backward invocation procedure of SS-CRT, or if the CRV does not have a higher value than that already saved for the call, the FE shall not send ISI-CRT-B.

#### 4.3.5 Actions of FE25

251: FE25 shall receive the ISI-CRT-F req/ind information flow from FE21 or from a previous FE23, and shall store the ISI-CRV-F value as the protection level for the duration of the call and shall convert it to a local CRV-F.

252: FE25 shall receive the CRT-B req/ind information flow from FE5 and check whether the user is provided with the backward invocation procedure of SS-CRT. The FE shall also check whether a CRV has been included in the CRT-B req/ind information flow received from FE5. If the backward



invocation procedure is provided, and if the CRV has a higher value than that already saved for the call, the FE shall save this value as the protection level for the duration of the call.

FE25 shall send an ISI-CRT-B req/ind information flow including an ISI-CRV-B to FE23 or FE21. If a CRV has been included in the CRT-B req/ind information flow received from FE5, the corresponding ISI-CRV-B shall be included in the ISI-CRT-B req/ind information flow sent to FE23 or FE21. If the user is not provided with the backward invocation procedure of SS-CRT, or if the CRV does not have a higher value than that already saved for the call, the FE shall ignore the CRT-B req/ind information flow received from FE5.

#### 4.3.6 Actions of FE5

501: The FE shall receive the user's request for call protection and send a CRT-B req/ind to FE25, optionally including CRV-B.

#### 4.4 Allocation of Functional Entities to physical equipment

Table 6 shows the allocation of Functional Entities to physical equipment. In this table, MS/LS indicates a MS/LS attached to a SwMI.

**Table 6: Scenarios for the allocation of FEs to physical equipment**

Scenario	FE1	FE21	FE23	FE25	FE22	FE5
1	Calling user MS/LS	Calling user SwMI	Transit SwMI	Called user SwMI	Group Call SwMI	Called user MS/LS

#### 4.5 Inter-working considerations

SS-CRT applies only to portions of a call that lie within the SwMI. For calls to and from other networks the Functional Entities are allocated to physical equipment as shown in table 7.

**Table 7: Scenarios for the allocation of FEs to physical equipment for normal operation in case of inter-working with another network**

Scenario	FE1	FE21	FE23	FE25	FE22	FE5
2	Other network	Incoming Gateway SwMI	Transit SwMI	Called user's SwMI	Called Group SwMI	Called user's TE
3	Calling user MS/LS	Calling user SwMI	Transit SwMI	Outgoing Gateway SwMI	Calling Group SwMI	Other network

## History

Document history	
December 1999	Public Enquiry PE 200015: 1999-12-15 to 2000-04-14