



**E**UROPEAN  
**T**ELECOMMUNICATION  
**S**TANDARD

**FINAL DRAFT**  
pr **ETS 300 392-11-20**  
May 1999

---

Source: TETRA

Reference: DE/TETRA-03001-11-20

ICS: 33.020

**Key words:** TETRA, radio, discrete

**Terrestrial Trunked Radio (TETRA);  
Voice plus Data (V+D);  
Part 11: Supplementary services stage 2;  
Sub-part 20: Discreet Listening (DL)**

**ETSI**

European Telecommunications Standards Institute

**ETSI Secretariat**

**Postal address:** F-06921 Sophia Antipolis CEDEX - FRANCE

**Office address:** 650 Route des Lucioles - Sophia Antipolis - Valbonne - FRANCE

**Internet:** [secretariat@etsi.fr](mailto:secretariat@etsi.fr) - <http://www.etsi.org>

Tel.: +33 4 92 94 42 00 - Fax: +33 4 93 65 47 16

---

**Copyright Notification:** No part may be reproduced except as authorized by written permission. The copyright and the foregoing restriction extend to reproduction in all media.

© European Telecommunications Standards Institute 1999. All rights reserved.



## Contents

Foreword .....	5
1 Scope .....	7
2 Normative references .....	7
3 Definitions and abbreviations .....	8
3.1 Definitions .....	8
3.2 Abbreviations .....	9
4 Supplementary Service Discreet Listening (SS-DL) Functional Model .....	9
4.1 Functional model description .....	9
4.2 Description of Functional Entities.....	10
4.2.1 Monitored user FE, FE1 .....	10
4.2.2 SS-DL FE in the SwMI, FE20 .....	11
4.2.3 SS-DL FE in the SwMI, FE27 .....	11
4.2.4 SS-DL FE in the SwMI FE21 .....	11
4.2.5 SS-DL in the SwMI FE22.....	11
4.2.6 Authorized user FE, FE3 .....	12
4.2.6.1 Monitoring user in a call FE, FE7.....	12
4.3 Relationship with a basic service .....	12
5 Information flows .....	14
5.1 Definition of information flows.....	14
5.1.1 ACTIVATE .....	14
5.1.2 ACTIVATE ACK .....	14
5.1.3 IDENTIFIER .....	15
5.1.4 INTERROGATE .....	15
5.1.5 INTERROGATE ACK.....	16
5.1.6 INFORM .....	16
5.1.7 INFORM ACK.....	17
5.1.8 INFO-TALKING-ITSI .....	17
5.1.9 MODIFY .....	18
5.1.10 MONITOR .....	18
5.1.11 MONITORED-CALL-CLEARED .....	19
5.1.12 RELEASE .....	19
5.1.13 TEMPORARY/PERMANENT-LEAVE .....	19
5.1.14 Information flow elements .....	20
5.2 Relationship of information flows to basic call information flows .....	20
5.3 Service primitives.....	20
5.4 Examples of information flow sequences .....	21
5.4.1 Activation/deactivation.....	21
5.4.2 Interrogation about monitored user status, SS-DL activation and type of bearer service.....	22
5.4.3 Operation of SS-DL in an Individual Call.....	22
5.4.4 SS-DL Normal Operation in case of Group Call.....	29
6 Functional entity actions.....	33
6.1 Functional Entity actions of FE1 .....	33
6.2 Functional Entity actions of FE21 .....	33
6.3 Functional Entity actions of FE7 .....	34
6.4 Functional entity actions of FE27 .....	35
6.5 Functional entity actions of FE22.....	36
6.6 Functional entity actions of FE3.....	36
6.7 Functional entity actions of FE20.....	36
7 Allocation of functional entities to physical equipment .....	37

8	Inter-working considerations.....	37
	History .....	38

## Foreword

This final draft European Telecommunication Standard (ETS) has been produced by the Terrestrial Trunked Radio (TETRA) Project of the European Telecommunications Standards Institute (ETSI), and is now submitted for the Voting phase of the ETSI standards approval procedure.

This ETS is a multi-part standard and will consist of the following parts:

- Part 1: "General network design";
- Part 2: "Air Interface (AI)";
- Part 3: "Inter-working";
- Part 4: "Gateways basic operations";
- Part 5: "Terminal equipment interface";
- Part 6: "Line connected stations";
- Part 7: "Security";
- Part 9: "General supplementary services design";
- Part 10: "Supplementary services stage 1";
- Part 11: "Supplementary services stage 2";**
- Part 12: "Supplementary services stage 3";
- Part 13: "SDL Model of the Air Interface (AI)";
- Part 14: "Protocol Implementation Conformance Statement (PICS) proforma specification".

<b>Proposed transposition dates</b>	
Date of latest announcement of this ETS (doa):	3 months after ETSI publication
Date of latest publication of new National Standard or endorsement of this ETS (dop/e):	6 months after doa
Date of withdrawal of any conflicting National Standard (dow):	6 months after doa

Blank page

## 1 Scope

This European Telecommunication Standard (ETS) specifies the stage 2 description of the Supplementary Service Discreet Listening (SS-DL) for the Terrestrial Trunked Radio (TETRA).

The SS-DL supplementary service discreet listening allows a user to monitor calls involving specified TETRA subscribers, either individuals or groups, or specified circuit mode basic services, or a specified combination of both.

Man-Machine Interface and charging principles are outside this ETS.

As an implementation option, this SS-DL may either result in a forced call clear or an intrusion in an existing call.

As defined in CCITT Recommendation I.130 [2], the stage 2 description identifies the functional capabilities and the information flows needed to support the Supplementary Service as specified in its stage 1 description ETS 300 392-10-20 [9]. The stage 2 identifies the functional capabilities for the management and operation of the service in the SwMI, in the MS and in the LS. Stage 2 describes also the information flows exchanged between these entities and the flows sent over the ISI.

NOTE: The stage 2 description is followed by the stage 3 description, which specifies the encoding rules for the information flows and process behavior for the different entities in SwMI, MS and LS.

## 2 Normative references

This ETS incorporates, by dated or undated reference, provisions from other publications. These normative references are cited at the appropriate places in the text and the publications are listed hereafter. For dated references, subsequent amendments to or revisions of any of these publications apply to this ETS only when incorporated in it by amendment or revision. For undated references the latest edition of the publication referred to applies.

- [1] ITU-T Recommendation I.112: "Vocabulary of terms for ISDNs".
- [2] CCITT Recommendation I.130 (1988): "Method for the characterization of telecommunication services supported by an ISDN and network capabilities of an ISDN".
- [3] ITU-T Recommendation I.210 (1993): "Principles of telecommunication services supported by an ISDN and the means to describe them".
- [4] ETS 300 171 (1992): "Private Telecommunication Networks (PTN) Specification, functional model and information flows; Control aspects of circuit mode basic services; ECMA-BCSD".
- [5] ETS 300 392-2 (1995): "Terrestrial Trunked Radio (TETRA); Voice plus Data (V+D), Part 2: Air Interface (AI)".
- [6] ETS 300 392-3-1 (1998): "Terrestrial Trunked Radio (TETRA); Voice plus Data (V+D); Part 3: Interworking at the Inter-System Interface (ISI); Sub-part 1: General design".
- [7] ETS 300 392-3-5: "Terrestrial Trunked Radio (TETRA); Voice plus Data (V+D) Part 3: Interworking at the Inter-System Interface (ISI); Sub-part 5: Additional Network Functions Mobility Management (ANF ISIMM)".
- [8] ETS 300 392-9 (1997): "Terrestrial Trunked Radio (TETRA); Voice plus Data (V+D); Sub-part 9: General requirements for supplementary services".
- [9] ETS 300 392-10-20 (1996): "Terrestrial Trunked Radio (TETRA); Voice plus Data (V+D); Part 10: Supplementary services stage 1; Sub-part 20: Discreet listening".

- [10] ETS 300 392-12-10: "Terrestrial Trunked Radio (TETRA); Voice plus Data (V+D); Part 12: Supplementary services stage 3; Sub-part 10: Priority Call (PC)".
- [11] ETS 300 392-12-20: "Terrestrial Trunked Radio (TETRA); Voice plus Data (V+D); Part 12: Supplementary services stage 3; Sub-part 20: Discreet Listening (DL)".
- [12] ETS 300 425 (1995): "Specification, functional models and information flows; Call intrusion supplementary service; ECMA-CISD".

### 3 Definitions and abbreviations

#### 3.1 Definitions

For the purposes of this ETS the following definitions apply:

**Authorized user:** User who is responsible for the activation and deactivation of the SS-DL. The authorized user may also interrogate the service access.

**Basic (...) service:** Any stand alone bearer service or tele-service (derived from ITU-T Recommendation I.210 [3]).

**bearer service:** Type of telecommunication service that provides the capability for the transmission of signals between user-network interfaces (defined in ITU-T Recommendation I.112 [1]).

**Call Intrusion:** SS-CI is a supplementary service which, on request from the monitoring user, enables the monitoring user to establish communication with a busy called user (monitored user) by breaking into an established call between monitored user and a third user. On successful intrusion, the monitored user and the monitoring user are connected in an individual call type of connection; the other user is placed on hold and is not part of the conversation. The SS-DL monitoring user has, by definition, a higher Call Intrusion Capability Level (CICL) than the Call Intrusion Protection Level (CIPL) of both monitored user and third user; both CICL and CIPL are defined in ETS 300 425 [12].

**Forced Release:** Release of the established call on request from the monitoring user during the intrusion state. (ETS 300 425 [12]). An implementation option that provides the monitoring user with additional capability following successful intrusion:

Forced release, allowing the served user to release the established call (derived from ETS 300 425 [12]).

**Functional Entity:** Functional Entity (FE) specifies the functional characteristics of a user involved in the management or operation functions of SS-DL.

**Line Station (LS):** Physical grouping that contains all of the fixed equipment that is used to obtain terrestrial access to TETRA services.

**Mobile station:** Physical grouping that contains all of the mobile equipment that is used to obtain TETRA services. By definition, a mobile station contains at least one Mobile Radio Stack (MRS).

**Monitored User:** User whose calls may be discretely listened to. Is considered as the served user in relation with ITU-T Recommendation I.210 [3]. May be called B-user occasionally.

**Monitoring user:** User who is given the capability to discretely listen to a call. May be called A user occasionally.

**Other user:** Any user who is involved in a call (individual or group) with the monitored user. May be called C-user occasionally.

**Supplementary service:** Any service provided by a network in addition to its basic service or services (defined in ITU-T Recommendation Q.9). A supplementary service modifies or supplements a basic telecommunication service. Consequently, it cannot be offered to a customer as a stand alone service. It must be offered together with or in association with a basic telecommunication service (excerpt from ITU-T Recommendation I.210 [3]).



**Switching and management infrastructure:** All of the TETRA equipment for a Voice plus Data (V+D) network. The SwMI enables subscriber terminals to communicate with each other via the SwMI.

**Tele-service:** Type of telecommunications service that provides the complete capability, including terminal equipment functions, for communication between users according to agreed protocols (defined in ITU-T Recommendation I.112 [1] except for a minor change at the end).

**Third user:** Any user who is neither the monitored user or the monitoring user; is similar to "other user".

### 3.2 Abbreviations

For the purposes of this ETS the following abbreviations apply:

CC	Basic service call control functional entity
CCA	Basic service call control functional entity

NOTE: CC and CCA are applied as defined in ETS 300 171 [4].

CI	Call Intrusion
FE	Functional Entity
GTSI	Group TETRA Subscriber Identity
ISI	Inter System Interface
ITSI	Individual TETRA Subscriber Identity
SS-DL	Supplementary service discreet listening
SDL	(Functional) Specification and Description Language
SS	Supplementary Service
SSI	Short Subscriber Identity
SwMI	Switching and Management Infrastructure
TETRA	Terrestrial Trunked Radio

## 4 Supplementary Service Discreet Listening (SS-DL) Functional Model

General principles guiding that section are compatible with ETS 300 392-9 [8] which shall apply wherever specific items pertaining to SS-DL are not specified.

### 4.1 Functional model description

The functional model describes the functional characteristics of the FEs involved in SS-DL.

The functional model shall comprise the following Functional Entities (FEs):

FE20 Authorized user home SwMI FE;  
FE21 Monitored User Current SwMI FE;  
FE22 Group Call Controlling SwMI FE;  
FE27 Monitoring User Current SwMI FE;  
FE3 Authorized User FE;  
FE7 Monitoring User ( similar to a Call Dispatcher) FE.

The following relationships shall exist between these FEs:

ra between FE7 and FE27;  
rb between FE27 and FE21;  
rc between FE27 and FE22;  
rd between FE3 and FE20;  
re between FE20 and FE21.

Figures 1, 2 and 3 show what shall be these FEs and their relationships for SS-DL.



Figure 1: The functional entities and relationships for SS-DL in case of Individual Call

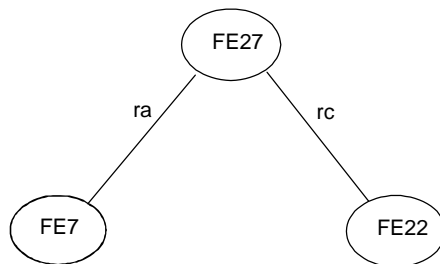

Figure 2: The functional entities and relationships for SS-DL in case of Group Call

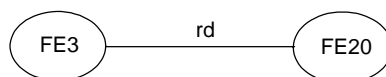

Figure 3: The functional entities for the management part of SS-DL

## 4.2 Description of Functional Entities

### 4.2.1 Monitored user FE, FE1

NOTE: FE1 is the functional entity that serves the monitored user application. There is no management SS-DL related function in FE1. Under normal circumstances, listened to user is not affected by the discreet listening service. Therefore, there is no information flow to FE1.

FE1 has access to the normal service, e.g. making or participating in individual/group calls; either the initiation of a call by FE1 or its participation in a call will invoke SS-DL (once activated) without FE1 knowledge.

In the optional case whereby the monitoring user FE7 requests call-intrusion into the existing call between the monitored user and a third user, the monitored user receives a call intrusion and finds itself connected to the monitoring user, the other user being left unconnected.

In the optional case whereby the monitoring user FE7 force-releases the call, the monitored user FE1 receives a disconnect indication with a cause SwMI requested disconnection, as stated in ETS 300 392-2 [5], subclause 14.8.18.

#### **4.2.2 SS-DL FE in the SwMI, FE20**

FE20 from/to the authorized user (FE3): The optional activation/deactivation procedure is supported by the home SwMI of the Authorized user, FE20 shall receive SS-DL activation/deactivation requests from FE3 and check them. For those requests that are found to be authorized and correct, it shall carry out the corresponding activation's/deactivations in the SwMI and shall confirm their completion to FE3. As to the others, FE20 shall reject them and inform FE3.

The same shall apply for the optional interrogation procedure supported by the home SwMI(s) of the Authorized user(s).

NOTE 1: The Authorized user is the same MS/LS for the activation/deactivation procedure and for the interrogation procedure.

The monitored user is the only managed user by FE20.

NOTE 2: All requests issued by the authorized user for an SS-DL managed user or group are to be addressed to the home SwMI of this monitored user or group. If the monitored user has migrated to another SwMI or if the group is attached in other SwMIs than the group home SwMI, ANF-ISIMM will update these SwMIs. So there is no need to show any monitored user visited SwMI FE.

It shall be possible to provide as an option permanent activation of SS-DL at provision time; in that case deactivation of SS-DL shall not be possible by authorized user actions; in that case, interrogation will still be possible as described above.

#### **4.2.3 SS-DL FE in the SwMI, FE27**

FE27 from/to the monitoring user (FE7): requests service invocation, notifies the user of the result of this and may deny the service partially or in full, respond to DL service profile requests for this monitored user, to present automatically (also valid at initial service set-up) the valid calls (in set-up phase or in progress) and upon interrogation, set-up and disconnect listening call or calls on request. FE27 may, on option, allow call-intrusion into the existing monitored call on request from FE7. In addition to the latter, FE27 may, on option, forward force-clear call to FE21 or FE22. FE27 is the monitoring user home SwMI and it is assumed that the monitoring user is not migrating to another SwMI.

#### **4.2.4 SS-DL FE in the SwMI FE21**

FE21 shall invoke SS-DL, shall present all useful information about all calls (in set-up or in progress) to FE27, shall accept the particular set-up of the listening call from FE7 via FE27, shall obey intrusion and disconnection requests from FE27 and send relevant information to the monitoring users FE7. FE21 shall provide all those functions for any individual call in which the monitored user is involved. On option, in the case where Call-intrusion is implemented, FE21 shall connect the monitoring user to the monitored user and the other user involved in that call shall be left unconnected.

In the case where the monitored user migrates to another SwMI, FE21 will pass to the new visited SwMI the activation information relating to SS-DL and the Call Intrusion parameters. A functional relation shall exist between FE20 and FE21 for exchange of user profiles.

#### **4.2.5 SS-DL in the SwMI FE22**

FE22 shall invoke SS-DL, shall present all useful information about all group calls (in set-up or in progress) to FE27, shall accept the particular set-up of the listening call from FE7 via FE27, shall obey disconnection request from FE27 and send relevant information to the monitoring users FE7. FE22 shall provide all those functions for any group call in which the monitored user is involved, whether the monitored user is registered for that group call or not. FE22 shall provide the group controlling functional entity. A functional relation may exist between FE20 and FE22 for exchange of user profiles.

#### **4.2.6 Authorized user FE, FE3**

FE3 shall set the DL service profile (which basic services, to which monitored user, for which monitoring users). If the optional activation/deactivation and/or interrogation procedures are supported by the authorized user MS/LS, FE3 shall send SS-DL activation/deactivation or interrogation requests to FE20. At the reception of the response from FE20, FE3 shall forward the result to the user application.

##### **4.2.6.1 Monitoring user in a call FE, FE7**

FE7 is the functional entity associated to the monitoring user. FE7 shall receive indications of all new calls being initiated by FE1, shall receive at activation of SS-DL, indications of all calls already in progress involving FE1 and shall be able to accept and to discretely listen to that call immediately or at a later time as long as the call is present. FE7 shall also be able to withdraw from a call at any time either on a temporary basis or on a permanent basis, at call set-up or later in the call. FE7 shall also be able to indicate that it never wishes to join that particular call. On option, FE7 shall be able to request intrusion into an existing monitored call and to forcefully clear that call.

FE7 shall not be able to modify its SS-DL profile.

FE7 and FE3 are coincident; however, for clarity they are split in the remaining part of the document; in the same manner, FE20 and FE27 shall be collocated but are described separately for the clarity of the document.

#### **4.3 Relationship with a basic service**

Although no formal model has been defined for basic individual call nor for basic group call, these models can be readily derived from the PISN model for basic call, in ETS 300 171 [4].

SS-DL service, as illustrated in figures 1 and 2 shall be applicable through the whole lifetime of a call. Therefore, the invocation of SS-DL shall always be in relationship with a basic call.

Being call unrelated, the activation/deactivation (when it exists) and interrogation procedures are independent from CC or CCA.

FE7 shall be collocated with a CCA.

FE21 shall be collocated with the originating/terminating CC associated with the monitored (calling or called) user.

FE22 shall be collocated with the transit CC which is controlling the group call.

FE27 shall be collocated with the terminating CC both in case of individual call and in case of group call.

Figures 4 and 5 show the relationship between the models for SS-DL and basic call in case of individual and in case of group call. In figure 4, FE21 provides the bridging capability between the basic monitored call and the additional monitoring user call. Route to the other user involved in the individual call has no importance and is shown only for clarity.

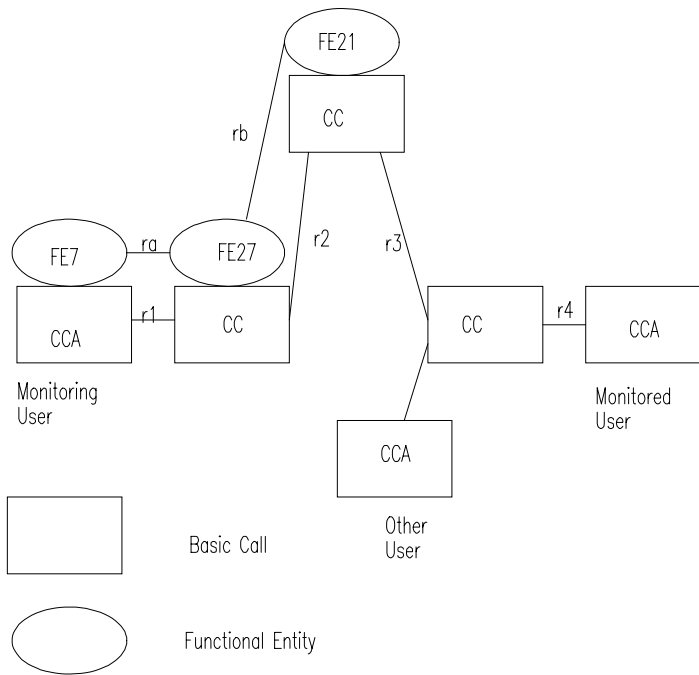

**Figure 4: The relationships between the models for SS-DL and basic call in the case of individual call**

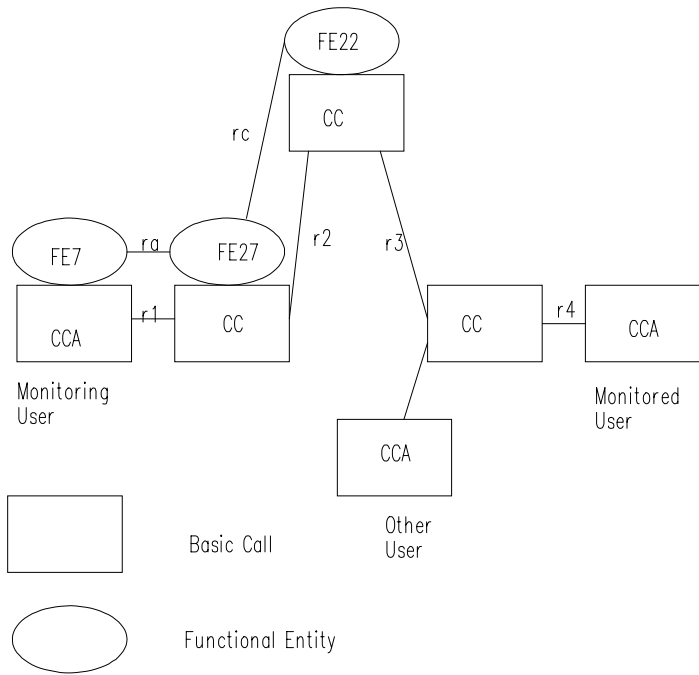

**Figure 5: The relationships between the models for SS-DL and basic call in the case of group call**

## 5 Information flows

### 5.1 Definition of information flows

In the tables listing the elements in information flows, the column header "Type" indicates which of the elements are Mandatory (M), Conditional (C) or Optional (O). If type is conditional, the conditions are stated. The format and content of the information flows that follow are derived from draft ETS 300 392-9 [8].

#### 5.1.1 ACTIVATE

ACTIVATE is an unconfirmed information flow across relationship rd from FE3 to FE20 which activates or deactivates SS-DL for one identity (either GTSIs or ITSIs). Each different ITSI/GTSI results in a separate activation/deactivation.

NOTE: The response/confirmation information flow corresponding to the ACTIVATE request/indication information flow is ACTIVATE ACK indication (see subclause 5.1.2).

Table 1 lists the elements within the ACTIVATE information flow.

**Table 1: Contents of ACTIVATE**

Element	Type
Activated/deactivated identity	M (note1 and note 2)
Activation/deactivation request	M
Access priority	O (note 5)
Type of basic service	M
Delay timer value	O (note 3 and note 4)
NOTE 1:	May be repeated.
NOTE 2:	May be a range of identities.
NOTE 3:	Delay timer value nxTAU to be used as an implementation option, to allow monitoring user to join the call without losing the start of the conversation.
NOTE 4:	For a group call, this delay will result in a delay for all participants in the group call.
NOTE 5:	When not provided, default value will be low priority.

The element activated/deactivated identity may include a GTSI or an ITSI. In the case where a monitored user joins a group call of which it is not a registered member, the monitored user ITSI needs to be used to insure proper invocation of the SS-DL.

The information element of the activation/deactivation request indicating possible activation options of SS-DL will be defined in ETS 300 392-12-20 [11].

When the monitored user moves to a new SwMI, the activation/deactivation shall not need to be repeated and the monitored user present SwMI shall transfer to the visited SwMI the SS-DL profile for that monitored user according to ETS 300 392-3-5 [7].

#### 5.1.2 ACTIVATE ACK

ACTIVATE ACK is actually the indication information flow corresponding to the ACTIVATE request information flow. It is thus across relationship rd from FE20 to FE3. It is used to acknowledge the activation state of SS-DL for one identity.

NOTE: The definition of how a given ACTIVATE ACK information flow relates to the corresponding ACTIVATE information flow is outside the scope of the stage 2 description: it will be given in the stage 3 description.

Table 2 lists the elements within the ACTIVATE ACK information flow.

**Table 2: Contents of ACTIVATE ACK**

Element	Type
Activated/deactivated identity	M (notes 1 and 4)
Activation/deactivation result	M (note 2)
Access priority	O (note 6)
Type of service	M (note 2)
Activation state	C (notes 2 and 3)
Timer value	M (note 5)
NOTE 1:	May be repeated.
NOTE 2:	Shall be repeated as appropriate if the element activated/deactivated identity is repeated.
NOTE 3:	Present if activation/deactivation result is positive.
NOTE 4:	As an implementation option, the identities and the results may be presented in a range.
NOTE 5:	Timer returned value 0 means not implemented or not used.
NOTE 6:	When not provided, will be set to default value which is low.

The information element activation/deactivation result will be defined in of ETS 300 392-12-20 [11], indicating if the ACTIVATE information flow request has been successful or not. If it has been successful, the information element activation state will be defined in ETS 300 392-12-20 [11], giving the details about SS-DL activation/deactivation.

### 5.1.3 IDENTIFIER

(SS-DL) IDENTIFIER request is an unconfirmed information flow across relation ra from FE7 to FE27 which is used to identify the SS-DL call to be monitored in response to the INFORM indication; it is associated with a basic call set-up allowing the monitoring user to join that call already in progress.

Table 3 lists the elements within the IDENTIFIER information flow.

**Table 3: Contents of IDENTIFIER**

Element	Type
Call reference	M
Monitoring point ITSI	M
SS-DL call	M

### 5.1.4 INTERROGATE

INTERROGATE is an unconfirmed information flow across relationship rd from FE3 to FE20 which is used to interrogate the home SwMI of a monitoring user known by its identity about:

- the activation state of SS-DL for a monitored user;
- the group/individual call this monitoring user is authorized to listen to;
- the type of bearer service.

NOTE: The response/confirmation information flow corresponding to the INTERROGATE request/indication information flow is INTERROGATE ACK (see subclause 5.1.4). Only one INTERROGATE request is assumed to be outstanding at any time.

Table 4 lists the elements within the INTERROGATE information flow.

**Table 4: Contents of INTERROGATE**

Element	Type
Interrogated identity	M (note)
NOTE: May be repeated.	

**5.1.5 INTERROGATE ACK**

INTERROGATE ACK is actually the response/confirmation information flow corresponding to the INTERROGATE request/indication information flow. It is thus across relationship rd from FE20 to FE3. It is used to respond to the corresponding interrogation request.

NOTE: The definition of how a given INTERROGATE ACK information flow relates to the corresponding INTERROGATE information flow is outside the scope of the stage 2 description: it is given in the stage 3 description.

Table 5 lists the elements within the INTERROGATE ACK information flow.

**Table 5: Contents of INTERROGATE ACK**

Element	Type
Interrogation result	M (note 1 and 2)
Activation/Deactivation state	M (note 2)
ITSI/GTSI Indication	M
Service type	M
NOTE 1: May be repeated.	
NOTE 2: Shall be repeated as appropriate if the element interrogated identity is repeated.	

**5.1.6 INFORM**

INFORM indication is a confirmed information flow used across either relationship ra from FE21 to FE27 or rc from FE22 to FE27 which delivers SS-DL indication to FE7.

NOTE: The response information flow corresponding to the INFORM indication information flow is either INFORM ACK (see subclause 5.1.6) or MONITOR request associated with U-SETUP (from monitoring user FE7).

INFORM contains the basic service information of the call to be monitored; INFORM also contains the monitoring point ITSI to allow the monitoring user to join that particular call in a discreet listening mode; this monitoring point ITSI will be used in the call set up (U-SETUP) when the monitoring user wishes to join in the call; on top of this monitoring point the call reference to be used to join that call shall be included in the INFORM information flow. One and only one outstanding INFORM will remain unacknowledged at any time. Repeat of INFORM is an implementation option. Table 6 lists the elements within the INFORM information flow. Range is not implemented in the INFORM information flow. INFORM shall be presented for any new call set-up matching the SS-DL activate parameters, for any call in progress matching the SS-DL activate parameters at the time SS-DL is activated and for any call already in progress the parameters of which change and match the SS-DL activate parameters.



Table 6: Contents of INFORM

Element	Type
Call in progress/New Call Set-up	M
ITSI/GTSI of Monitored User	M (note 1)
ITSI of the other user engaged in the call	M
Monitoring point ITSI to join in that call in discreet listening	M
Basic service information	M
Call reference	M
Call priority	M
Half duplex/Duplex	C (note 2)
Intrusion allowed	O
Forced clearing allowed	O
NOTE 1: Even a group of which the monitored user is not a registered member will be reported.	
NOTE 2: Conditional on individual call or not.	

### 5.1.7 INFORM ACK

INFORM ACK is actually the response information flow corresponding to the INFORM indication information flow in the case where the monitoring user does not decide to join the call immediately. It is thus across relationship ra from FE27 to FE7. It is used to respond to the corresponding inform indication and to indicate that the INFORM has been properly received even though no direct action has resulted from that INFORM. FE7 will be the initiator of that INFORM ACK (which will go through the air interface for a MS and which precludes the use of ROSE encoding). The reply NO will indicate that the monitoring user does not wish to join the call at this time while the answer NEVER will indicate that the monitoring user will never wish to join that call at any time. If monitoring user is absent or has turned off his terminal, the lack of INFORM ACK will result in a SS-DL deactivation.

NOTE: The definition of how a given INFORM ACK information flow relates to the corresponding INFORM information flow is outside the scope of the stage 2 description: it is given in the stage 3 description.

Table 7 lists the elements within the INFORM ACK information flow.

Table 7: Contents of INFORM ACK

Element	Type
NO/NEVER for that call	M
Monitoring Instance Identifier	M
Monitoring point ITSI used in INFORM	M (note)
NOTE: Monitoring point ITSI is what is needed to join the call already in progress in monitored user SwMI or in group controlling SwMI.	

### 5.1.8 INFO-TALKING-ITSI

INFO-TALKING-ITSI indication is an unconfirmed information flow used across either relationship rb from FE21 to FE27 or relationship rc from FE22 to FE27 which delivers talking user identity indication to FE7. In an individual call and in the case of half duplex operation, the talking user identity can be either the monitored user or the other user identity; in case of group call, it is the identity of the talking user. The content of this INFO-TALKING-ITSI is identical to the D-TX-GRANTED PDU.

**5.1.9 MODIFY**

MODIFY indication is an unconfirmed information flow for SS-DL monitoring user across either relationship rb from FE21 to FE27 or rc from FE22 to FE27 which delivers to the monitoring user the information that the basic service for the call to be monitored has been modified either by the monitored user or by any other user. MODIFY may be provided to the monitoring user either when he has already joined the call in a discreet listening mode or in the case where he has temporarily indicated that he did not wish to join the call. As a result of the MODIFY indication, the monitoring user may decide to leave the call temporarily if he was already involved in that call or he may decide to join the call due to the change of the call nature. The MODIFY information flow shall exist even in the case where the new parameters for the call resulting from the change are outside the ACTIVATE range of parameter values allowed to the monitoring user. The monitoring user shall be informed of the change in those call parameters and if those new call parameters fall out of the authorized range, the monitoring user shall be disconnected from the SS-DL call. At this point, the monitoring user may decide to change its ACTIVATE parameters; if those new parameters fall within the range of the call parameters (as recently modified), the monitoring user shall receive an INFORM information flow and may either join the call in progress or not join at that time of definitively.

Table 8 lists the elements within the MODIFY information flow.

**Table 8: Contents of MODIFY**

Element	Type
Call reference	M
Half duplex/duplex	M
Basic service	M (note)
NOTE:	New basic service parameters resulting from the modify request.

**5.1.10 MONITOR**

MONITOR is actually the response information flow corresponding to the INFORM indication information flow in the case where the monitoring user decides to join the call immediately. It is thus across relationship ra from FE27 to FE7. It is used to respond to the corresponding inform indication and to indicate that the INFORM has been properly received and the direct action resulting from that INFORM is a SETUP SS-DL call. FE7 will be the initiator of that MONITOR (which will go through the air interface for a MS and which precludes the use of ROSE encoding).

NOTE 1: The definition of how a given MONITOR information flow relates to the corresponding INFORM information flow is outside the scope of the stage 2 description: it is given in the stage 3 description.

NOTE 2: There are two priorities, one set up as part of the call setup (call priority) and one access priority as part of this MONITOR information flow; the relation between the two if any is outside the scope of this ETS.

Table 9 lists the elements within the MONITOR information flow.

**Table 9: Contents of MONITOR**

Element	Type
Access priority	M
Monitoring Instance Identifier	M
Monitoring point ITSI used in INFORM	M (note)
NOTE:	Monitoring point ITSI is what is needed to join the call already in progress in monitored user SwMI or in group controlling SwMI.

**5.1.11 MONITORED-CALL-CLEARED**

MONITORED-CALL-CLEARED indication is an unconfirmed information flow used across either relationship rb from FE21 to FE27 or relationship rc from FE22 to FE27 which delivers to FE7 the indication that the monitored call has been cleared even though the monitoring user had not joined the call at any time; its main purpose is to clear any call reference pertaining to that cleared call to avoid joining another call with the same call reference at a later point in time. This MONITORED-CALL-CLEARED information flow shall be sent only in the case where the monitoring user has not replied NEVER in the INFORM response.

Table 10 lists the elements within the MONITORED-CALL-CLEARED information flow.

**Table 10: Contents of MONITORED-CALL-CLEARED**

Element	Type
Call reference	M
Basic Service	M
Monitored user ITSI	M

**5.1.12 RELEASE**

RELEASE request is an unconfirmed information flow used across relation rb between FE7 and FE27 in case of group call to indicate that the SS-DL nature of the call is to be released to allow the monitoring user to join the call as a normal group user. This RELEASE information flow normally takes place prior to an intrusion.

Table 11 lists the elements within the RELEASE information flow.

**Table 11: Contents of RELEASE**

Element	Type
Call reference	M
Basic Service	M (note)
Monitoring Point ITSI	M
NOTE: Basic service is needed in the case where both a data call and a speech call exist and only one of the two is released to prepare for intrusion; it is most likely that intrusion will occur only for a non data non encrypted speech call so that basic service needs to indicate such facts.	

**5.1.13 TEMPORARY/PERMANENT-LEAVE**

TEMPORARY/PERMANENT-LEAVE indication is an unconfirmed information flow used across either relationship ra FE7 to FE27 which delivers to FE27 the indication that the monitoring user wishes to temporarily leave the SS-DL call with either the intention of joining that same call again later or leaving that call until its completion. This temporary leave information is different from a disconnect of the monitored call, a call intrusion or a forced release of the call. This temporary leave information has no meaning when SS-DL is not invoked and is abnormal in case of no call in process.

Table 12 lists the elements within the SS-DL TEMPORARY/PERMANENT-LEAVE information flow.

**Table 12: Contents of TEMPORARY/PERMANENT-LEAVE**

Element	Type
Call reference	M
Basic Service	M
Monitoring point ITSI	M
Temporary/Permanent Leave	M

**5.1.14 Information flow elements**

The element contents of the information flows are derived from the service primitives and operational and management requirements. Unless they are self-explanatory (e.g. user identity), the corresponding PDU information elements defined in ETS 300 392-12-20 [11] on the stage 3 description of SS-DL will have the same name as these elements.

**5.2 Relationship of information flows to basic call information flows**

The SS-DL information flows for activation, deactivation, inform and interrogation between all entities should be sent with FACILITY PDU.

Table 13 summarizes the relationship of SS-DL information flows to those of the basic SS-DL call both over the air interface and intersystem interface (ISI).

NOTE: There are in fact two basic calls involved in SS-DL, one is the call from the monitored user to the other user and one is the SS-DL call proper; the relationships shown below indicate relations to basic SS-DL call.

**Table 13: The relationship of SS-DL information flows to basic SS-DL call information flows**

Information flow	Independent of basic call?	With basic call?	Basic call flows:
ACTIVATE	yes	no	
ACTIVATE ACK	yes	no	
INTERROGATE	yes	no	
INTERROGATE ACK	yes	no	
INFORM	yes	no	
INFORM ACK	yes	no	
INFO-TALKING-ITSI	yes	no	with A to B basic call; independent of SS-DL basic call.
MODIFY	yes	no	with A to B basic call; independent of SS-DL basic call.
MONITOR	no	yes	"basic" SS-DL call
MONITORED-CALL-CLEARED	yes	no	with A to B basic call; independent of SS-DL basic call.
RELEASE	yes	no	
TEMPORARY/PERMANENT-LEAVE	yes	no	

**5.3 Service primitives**

This clause lists SS-DL service primitives used to activate or being a result of information flow sequences. The SS-DL service primitives are defined in ETS 300 392-12-10 [10] subclause 5.4 and the basic call service primitives are defined in ETS 300 392-2 [5], clause 11.

The SS-DL service primitives for the user A (FE7) at the MS/LS TNSS-SAP shall be:

- INFORM ACK response;
- INFORM indication;
- INFO-TALKING-ITSI indication;
- MODIFY indication;
- MONITOR request;
- MONITORED-CALL-CLEARED indication;
- RELEASE request;
- TEMPORARY/PERMANENT-LEAVE request.

NOTE: INFORM primitive may have several responses which are MONITOR request and INFORM ACK response.

The SS-DL service primitives for the authorized user (FE3) at the MS/LS TNSS-SAP shall be:

- ACTIVATE request;
- ACTIVATE ACK indication; (in fact a confirm of ACTIVATE request);
- INTERROGATE request;
- INTERROGATE ACK indication; (in fact a confirm of INTERROGATE request).

#### 5.4 Examples of information flow sequences

ETS 300 392-12-20 [11], on SS-DL stage 3 description, specifies the signaling procedures in support of the information flow sequences specified in the following sub clauses. In addition, it specifies signaling procedures to cover other sequences arising from service specific error situations, interactions with basic call, interactions with other supplementary services, different topologies etc.

In the following figures, SS-DL information flows are represented by solid arrows and basic call information flows are represented by broken arrows. An ellipse embracing two information flows indicates that the two information flows occur together. Within a column representing an SS-DL functional entity, the numbers refer to functional entity actions listed in clause 6.

NOTE: The information flow sequences are examples and they may not cover all possible variations of the service.

##### 5.4.1 Activation/deactivation

Figure 6 shows the information flow sequences of SS-DL activation/deactivation. The activate has in fact two destinations: the monitored user home SwMI and the monitoring/authorized user home SwMI. The authorized user gets only one ACTIVATE ACK which is generated by the authorized user home SwMI upon reception of the ACTIVATE ACK2 from the monitored user home SwMI and its own activate acceptance. Both ACTIVATE and ACTIVATE2 have same content. In the case where both home SwMIs are collocated, FE201 and FE202 can be merged into FE20.

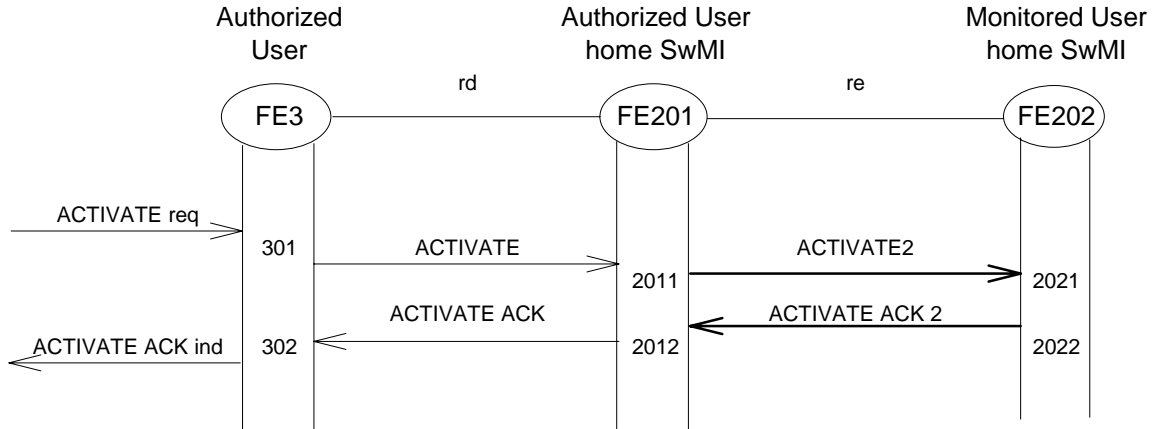

**Figure 6: Activation of SS-DL**

NOTE 1: A permanent activation of SS-DL may replace this information flow sequence.

NOTE 2: FE201 needs to participate in the ACTIVATE sequence to keep informed of FE3 activities in SS-DL.

5.4.2 Interrogation about monitored user status, SS-DL activation and type of bearer service

Figure 7 shows the information flow sequence for normal operation of SS-DL interrogation about identity, activation and status. The activate has in fact two destinations: the monitored user home SwMI and the monitoring/authorized user home SwMI. The authorized user gets only one ACTIVATE ACK which is generated by the authorized user home SwMI upon reception of the ACTIVATE ACK2 from the monitored user home SwMI and its own activate acceptance. Both ACTIVATE and ACTIVATE2 have same content. In the case where both home SwMIs are collocated, FE201 and FE202 can be merged into FE20.

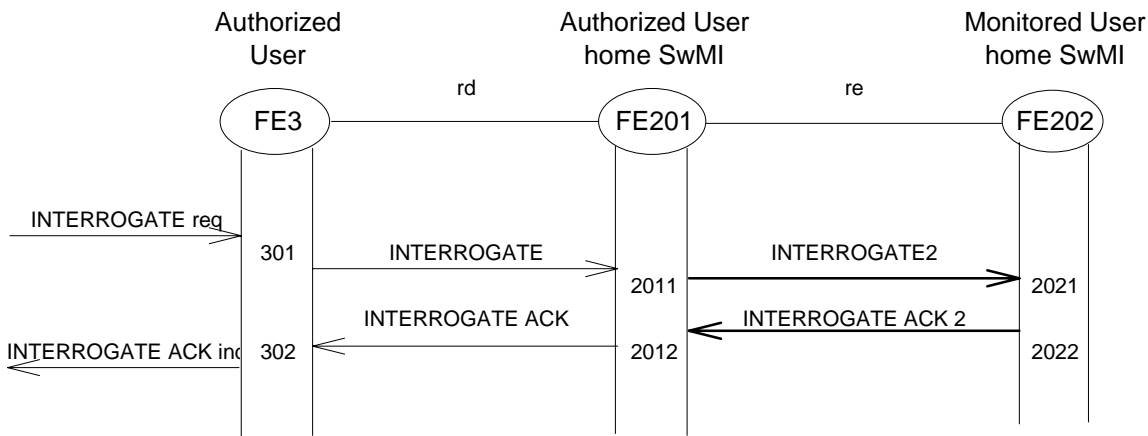

Figure 7: Interrogation of SS-DL

5.4.3 Operation of SS-DL in an Individual Call

Figure 8 shows the information flow sequence for normal operation of SS-DL applied in an individual call in the case where monitoring user activates SS-DL after the start of the individual call.

Figure 9 shows the information flow sequence for normal operation of SS-DL applied in an individual call in the case where the monitoring user joins immediately the call that is presented to him.

Figure 10 shows the information flow in the case where the talking user identity is presented to the monitoring user in the case of an individual call.

Figure 11 shows the information flow sequence for normal disconnect of a call involved in an SS-DL.

Figure 12 shows the information flow in the case where the monitoring user leaves temporarily the SS-DL call and rejoins that same call at a later time.

Figure 13 shows the case where the monitoring user has not joined the call and the monitored call is cleared.

Figure 14 shows the information flow in the case where the monitored user modifies the basic service parameters during a call and where those new parameters fall outside the range of authorized basic service allocated to the monitoring user.

Figure 15 shows the information flow sequence in the case where the monitoring user immediately invokes intrusion into the call that is presented to him.

Figure 16 shows the information flow sequence in the case where the monitoring user forcefully clear the monitored call after intrusion into that individual call.

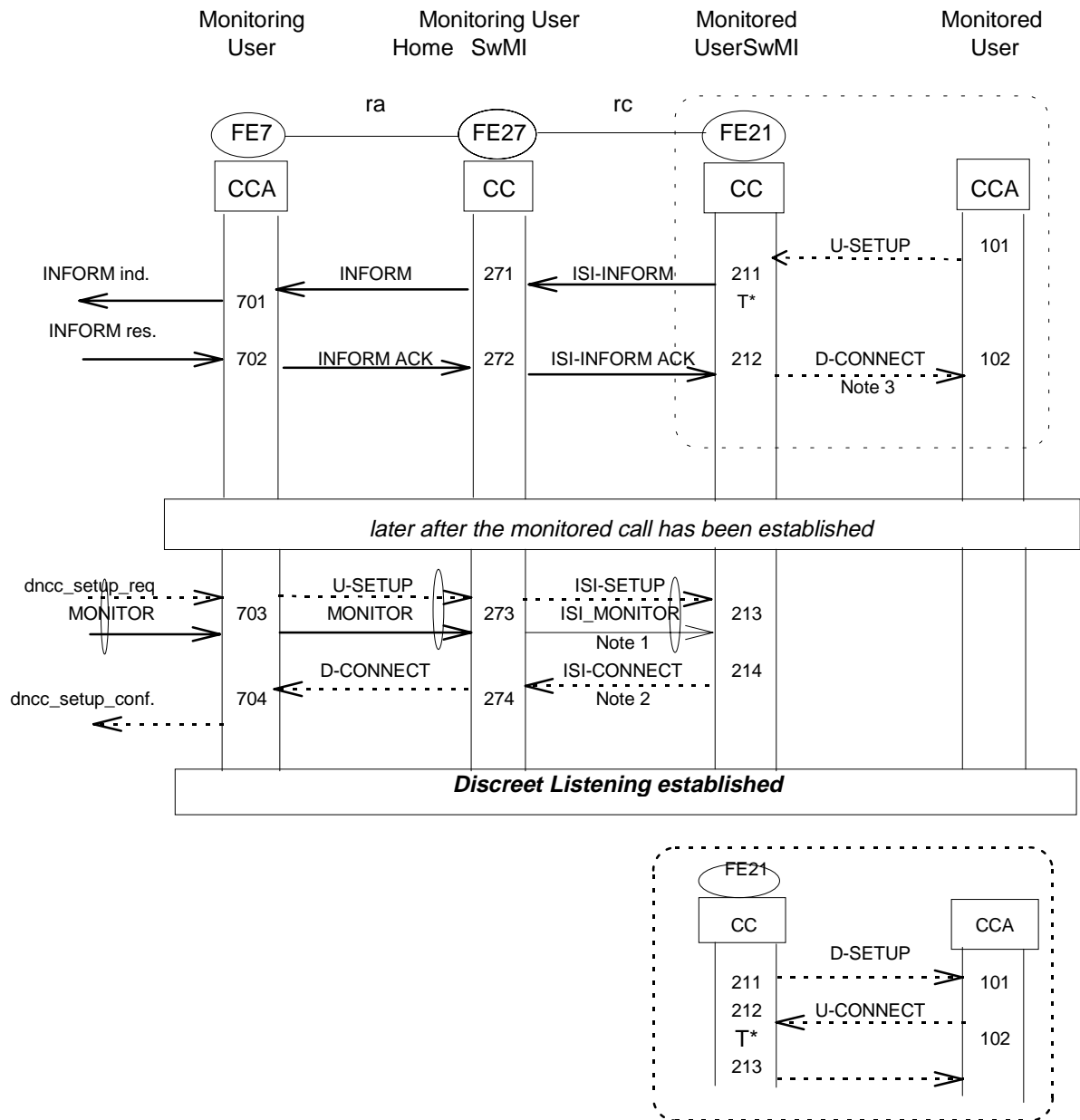

- NOTE 1: ISI-SETUP must be recognized as a SET-UP associated with SS-DL which implies that the SET-UP result must only be a down link set-up and must not give the monitoring user transmit capability. SS-DL has been activated prior to the new call set up.
- NOTE 2: Actual network resource is allocated at this point.
- NOTE 3: Monitored user is connected independently of the SS-DL monitoring user acceptance of the call to be monitored after expiration of timer T\*(see description of 211).

**Figure 8: Operation of SS-DL in the case of an individual outgoing new call with delayed acceptance of DL-call**

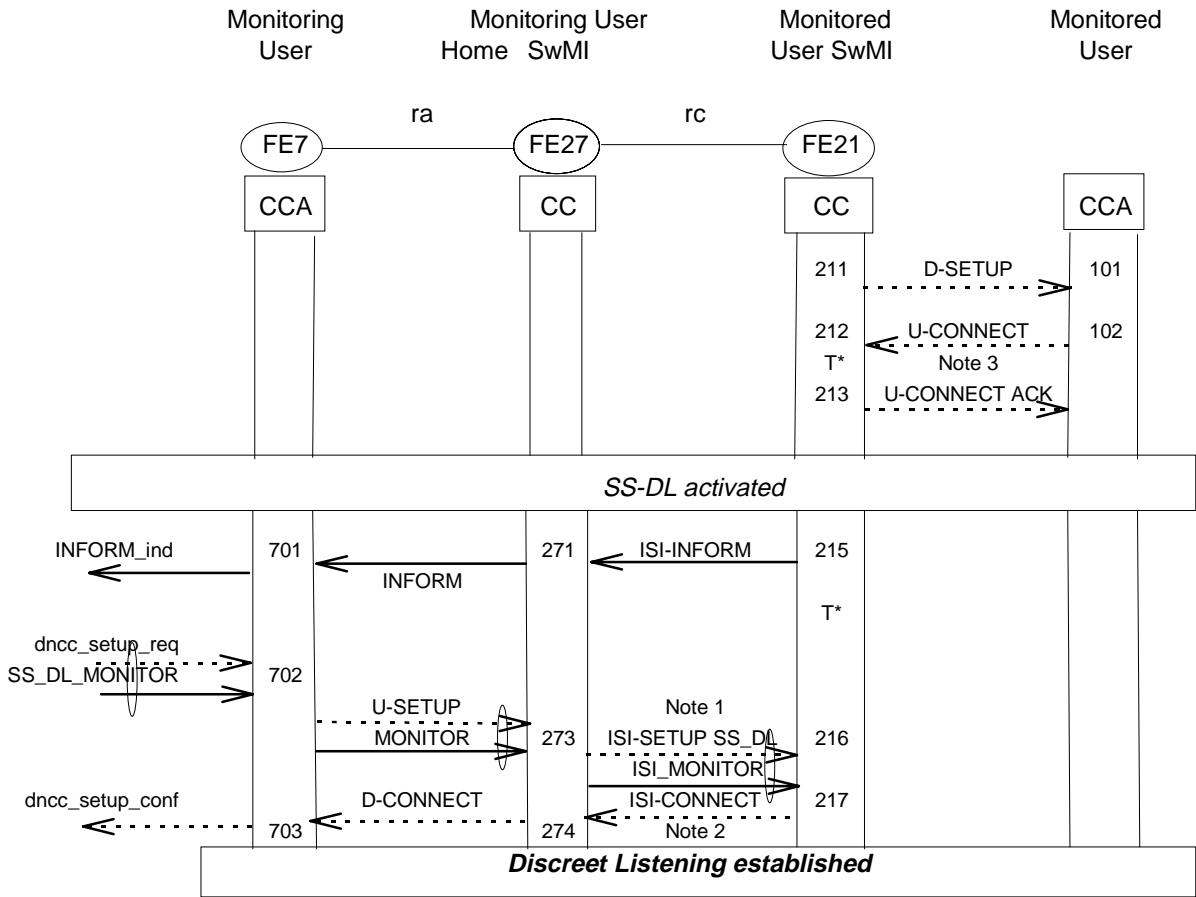

- NOTE 1: ISI-SETUP must be recognized as a SET-UP associated with SS-DL which implies that the SET-UP result must only be a down link set-up and must not give the monitoring user transmit capability. SS-DL has been activated prior to the new call set up.
- NOTE 2: Actual network resource is allocated at this point.
- NOTE 3: Monitored user is connected independently of the SS-DL monitoring user acceptance of the call to be monitored after expiration of timer shown T\*(see description of 211).

**Figure 9: Operation of SS-DL in the case of an existing incoming call with immediate acceptance of DL-call**



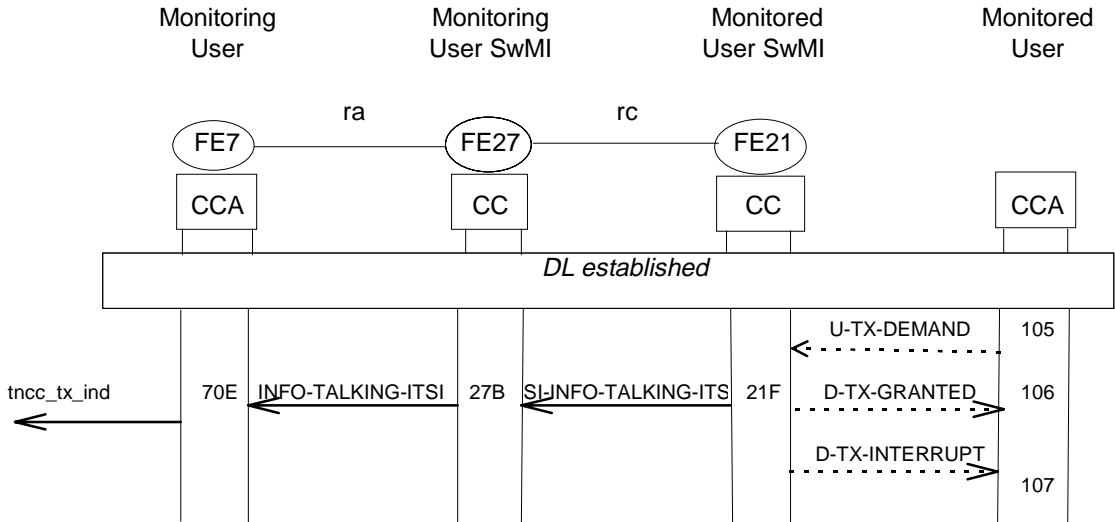

Figure 10: Operation of SS-DL identification of the talking user in case of individual call

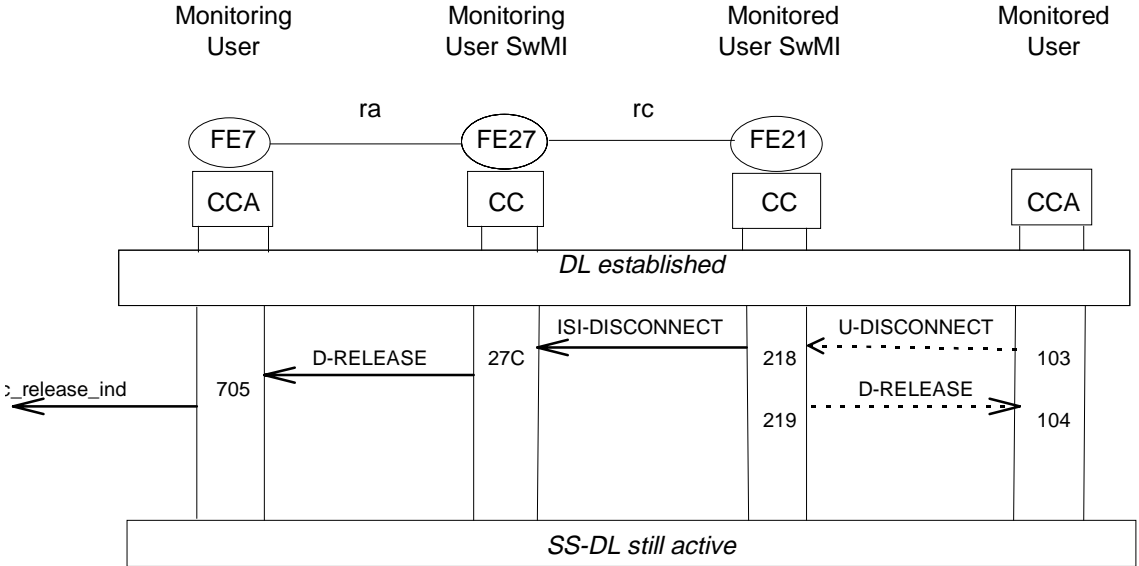
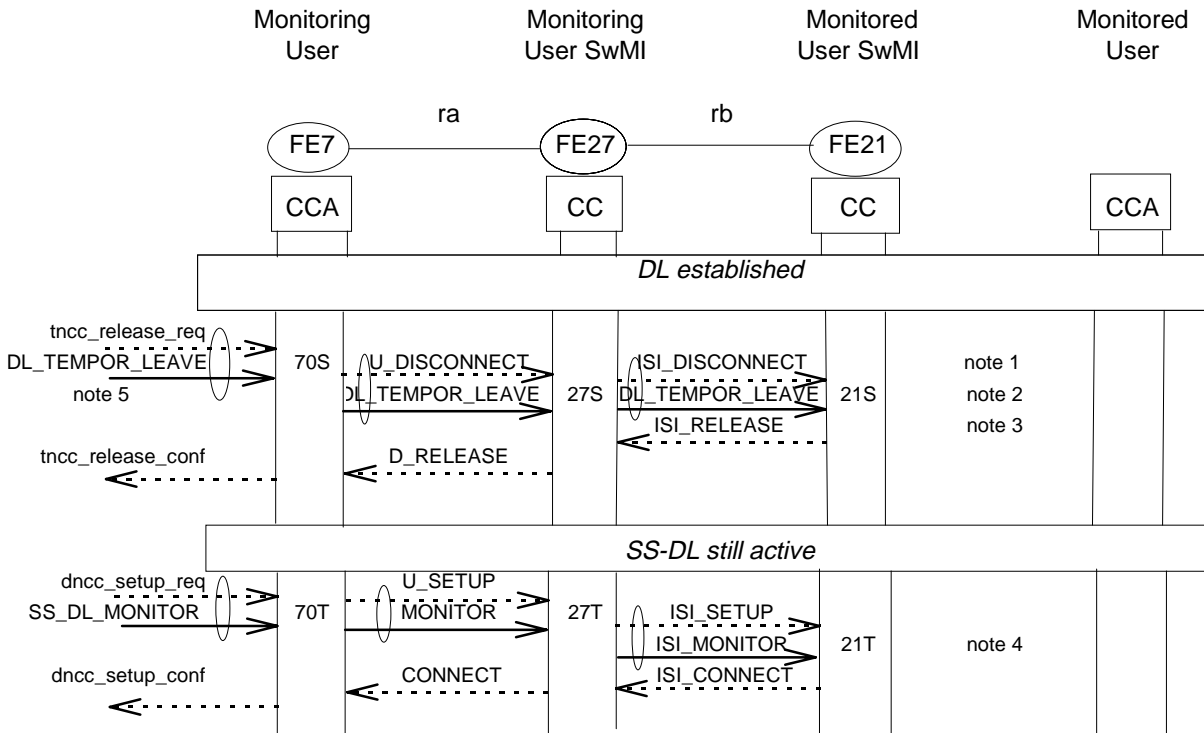

Figure 11: Normal Individual Call Disconnect



- NOTE 1: The same information flow applies to the case of a group call.
- NOTE 2: Only the monitoring user leaves temporarily the call; all other parties are not affected and not informed of the fact that monitoring user leaves the call.
- NOTE 3: Upon the monitoring user leaving the discretely listened to call, the monitoring user should be able to receive the monitored call cleared information flow.
- NOTE 4: At that point the situation is identical to the situation found in the case where SS-DL call was joined at a later time. Monitoring user can leave SS-DL call again temporarily; call disconnect may happen as well as call intrusion and forced release of the call.
- NOTE 5: When leaving the call, the monitoring user may indicate that he will NEVER join that call again or indicate that he is leaving momentarily the SS-DL call. The name DL-TEMPOR-LEAVE indicates in fact the flow DL TEMPORARY/PERMANENT LEAVE. In that case there will not be any MONITOR flow.

**Figure 12: Case where monitoring user leaves the SS-DL call without forceful release of the call**

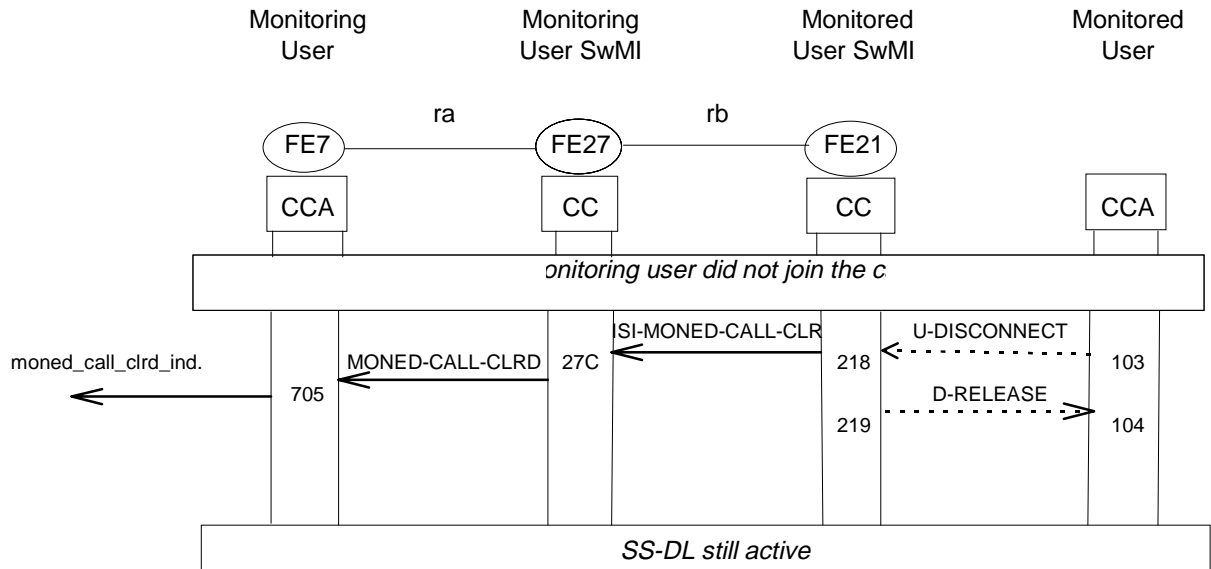
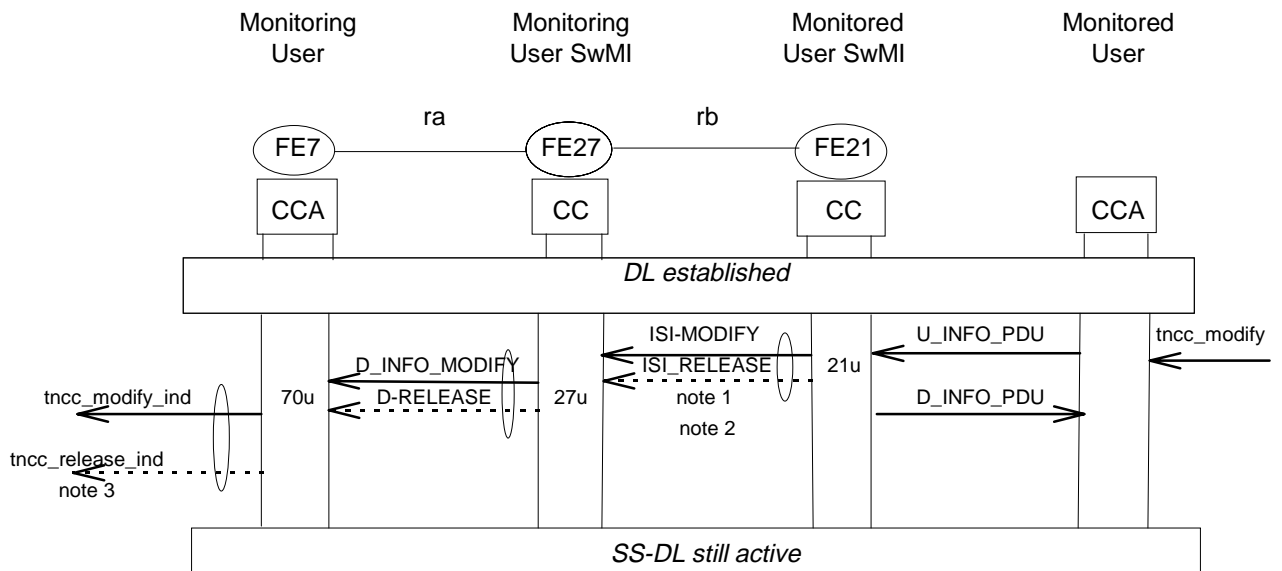
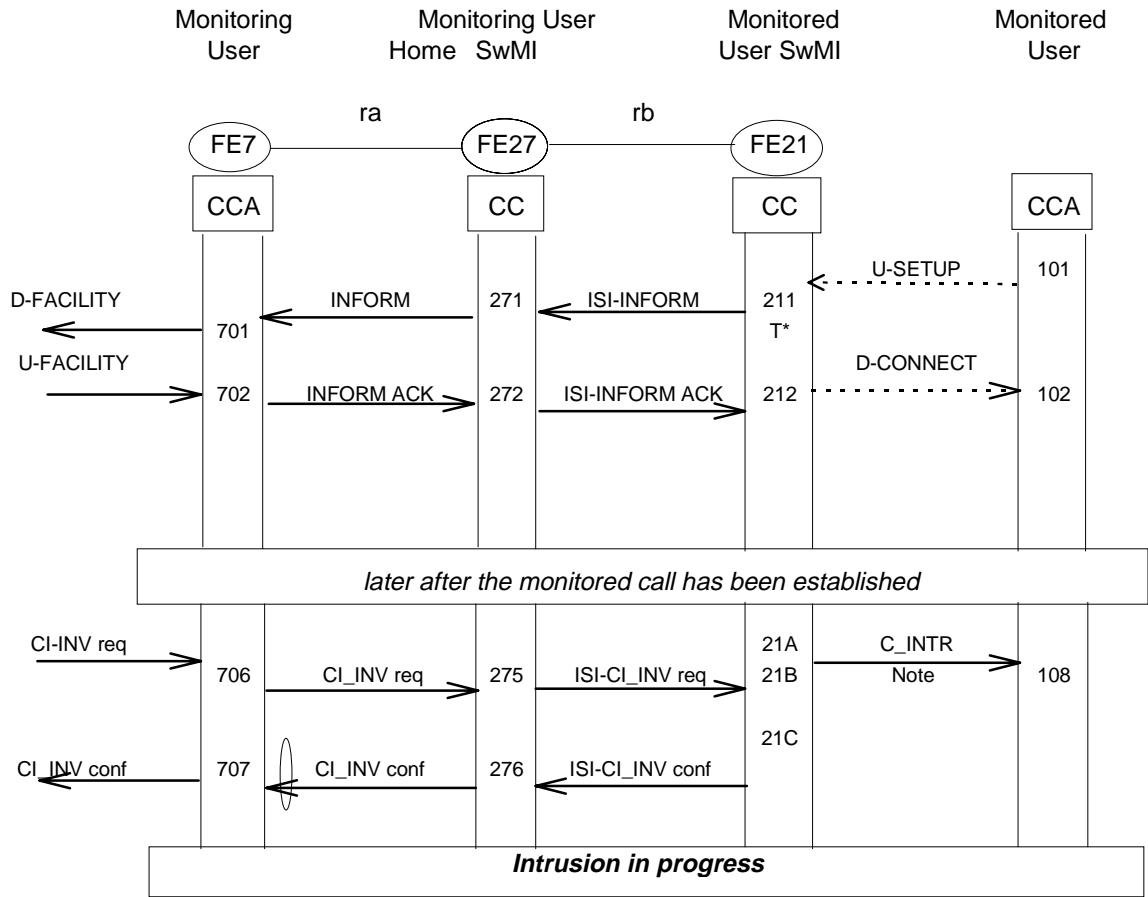

Figure 13: Normal Individual Call Disconnect Monitoring user is informed of the clear of the monitored call that he did not wish to join



- NOTE 1: ISI-RELEASE is generated when the basic service parameters resulting from the modify fall out the range of the authorized basic service parameters.
- NOTE 2: SS-DL is still active with the previous activation basic service parameters.
- NOTE 3: The monitoring user may change its activation parameters and rejoin the call in progress through the inform/setup process.

Figure 14: Operation of modification of basic service parameters during a call in progress



**NOTE:** Call Intrusion does not release SS-DL; Call Intrusion is done in the case of TETRA with path retention. The monitored user and the monitoring user are connected as a result of the intrusion in either half duplex or duplex according to the mode the monitored user was in at the time of the intrusion; the other user in the call is notified of the call intrusion and then disconnected. This is also the preferred solution when the call is a non speech call since a three user call with warning tone would have unexpected effects on a data call. As an implementation option, and in the case of duplex call, the call intrusion could be handled by a modify which would change the full duplex nature of the call into a half duplex call going back in that case to a group call type of operation.

**Figure 15: Immediate intrusion in individual call**

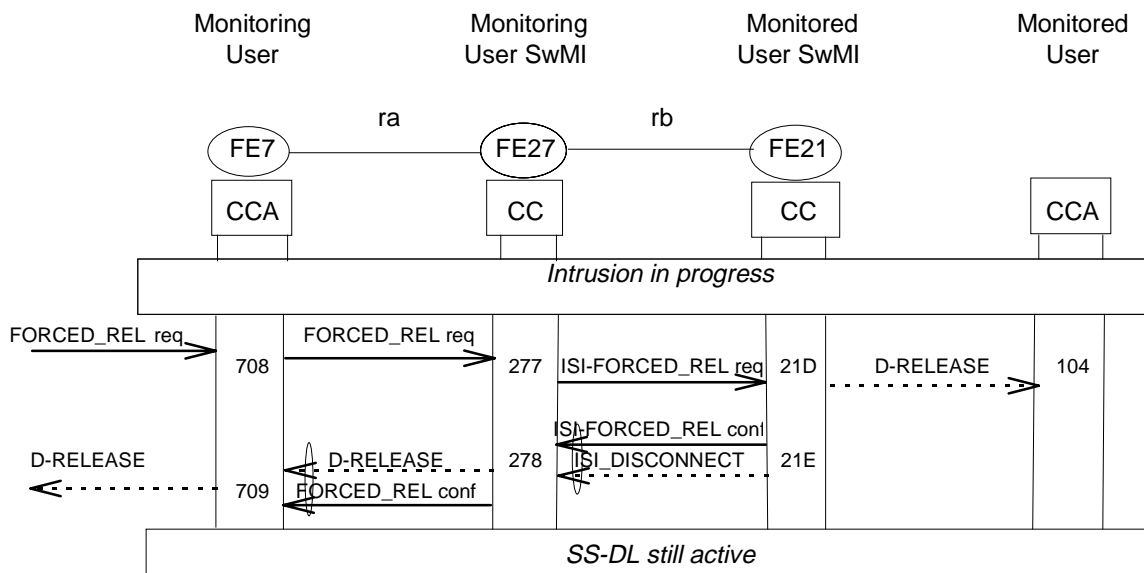
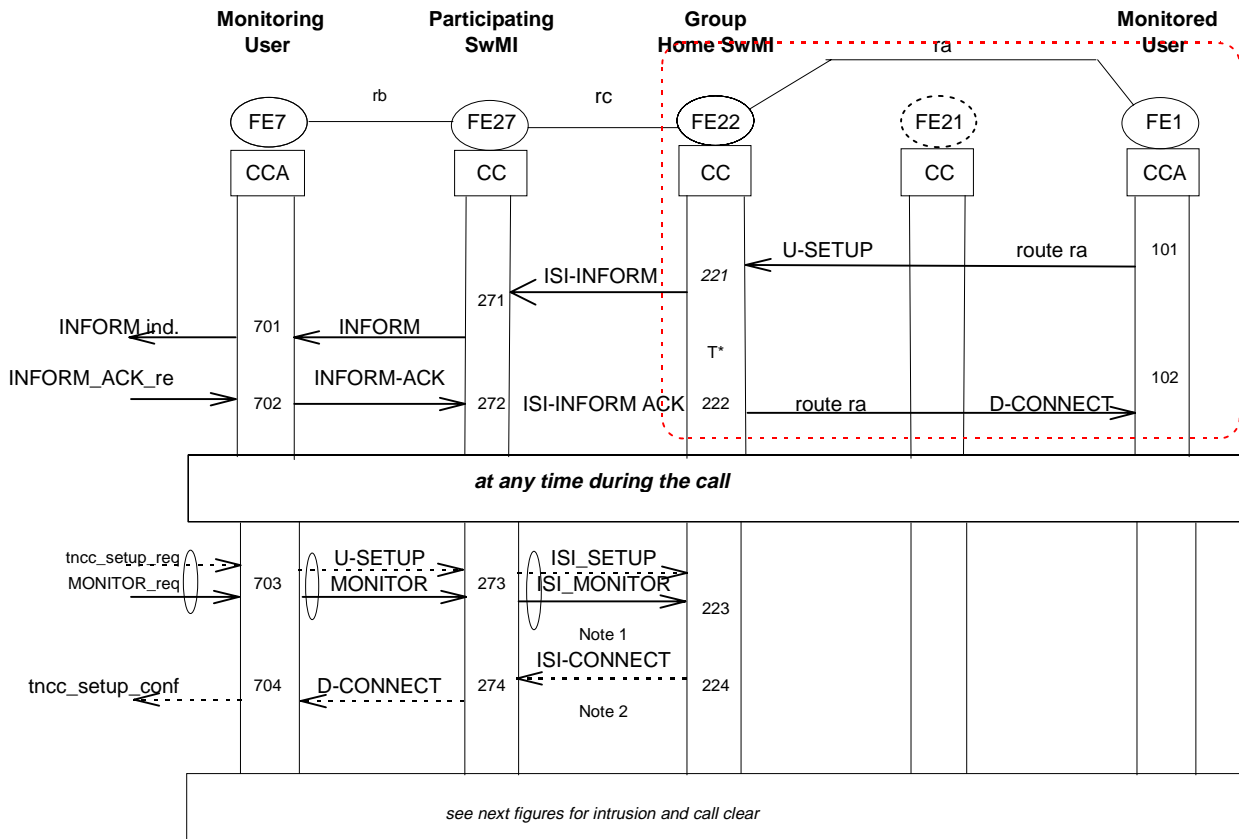

Figure 16: Forced individual call clearing

5.4.4 SS-DL Normal Operation in case of Group Call

Figure 17 shows the normal information flow sequence in the case of a group call. Figure 18 shows the variance in the case where the monitored user is called by any other user (including the monitoring user). Figure 19 shows the information flow sequence in the case of a group call where any talking user has to be identified to the monitoring user. Figure 20 shows the case where the monitored user is leaving a call that the monitoring user has not joined. Figure 21 shows the information flow sequence for the case of intrusion of the monitoring user in a group call that has been monitored for some time. Figure 22 shows the case of the group call forced clearing by the monitoring user.



NOTE 1: ISI-SETUP must be recognized as a SET-UP associated with SS-DL which implies that the SET-UP result must only be a down link set-up and must not give the monitoring user transmit capability.

NOTE 2: Actual network resource is allocated at this point.

NOTE 3: Monitored user is connected independently of the SS-DL monitoring user acceptance of the call to be monitored.

**Figure 17: SS-DL Operation in case of Group Call, monitored user is calling user**

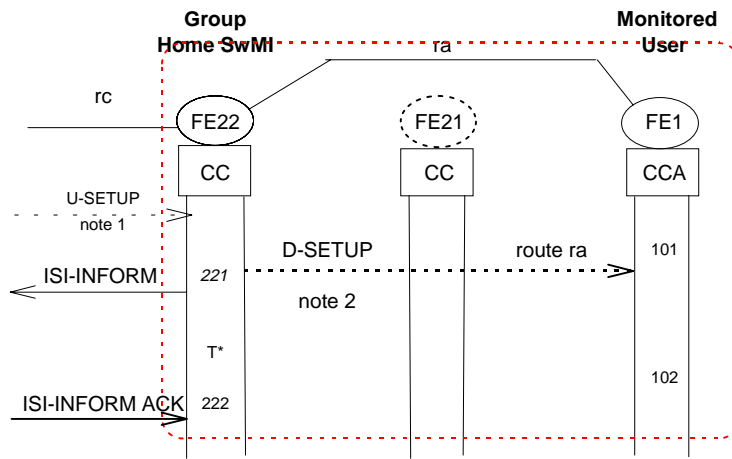

NOTE 1: Any user member of the group may initiate the call.

NOTE 2: In case the monitoring user finds the monitored user engaged in another call, ISI-INFORM is still sent and the monitoring user may join in the call by activating SS-DL.

**Figure 18: Variance to group call operation when monitored user is called**

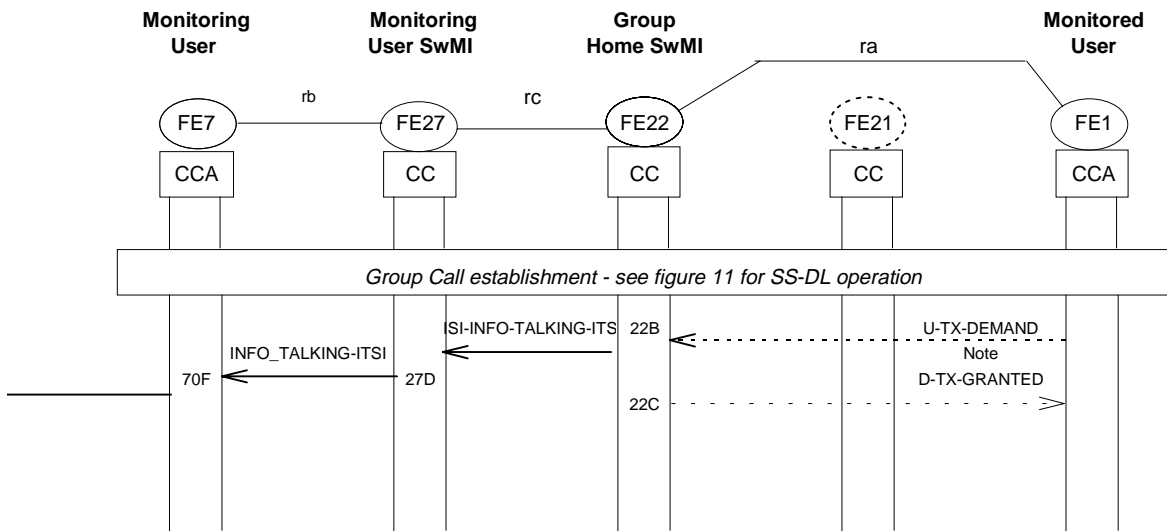

NOTE: While shown for the monitored user, this applies to any user in the group.

**Figure 19: Operation of SS-DL identification of the talking user in a group**

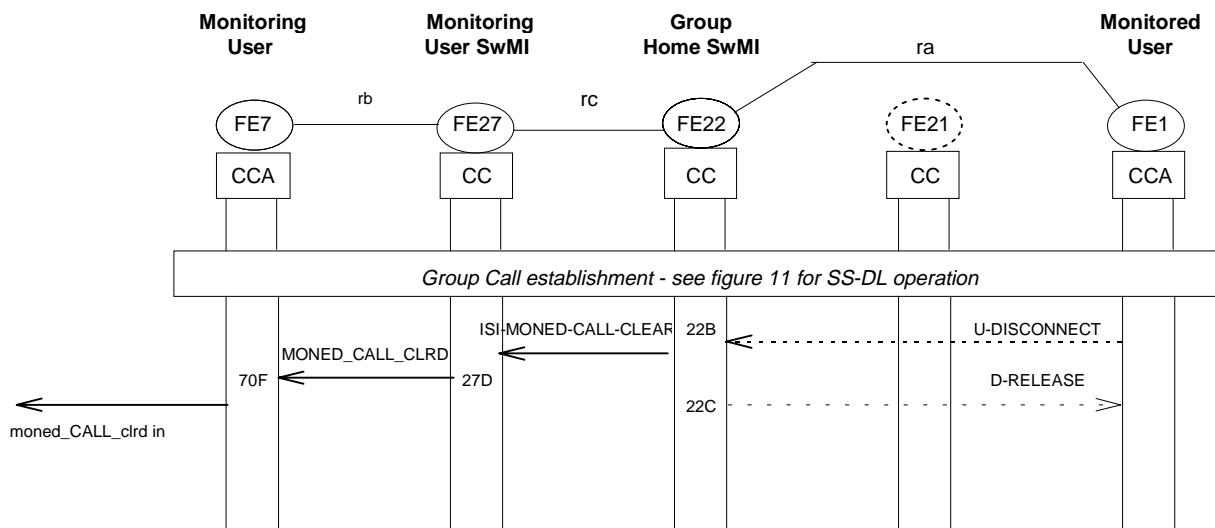
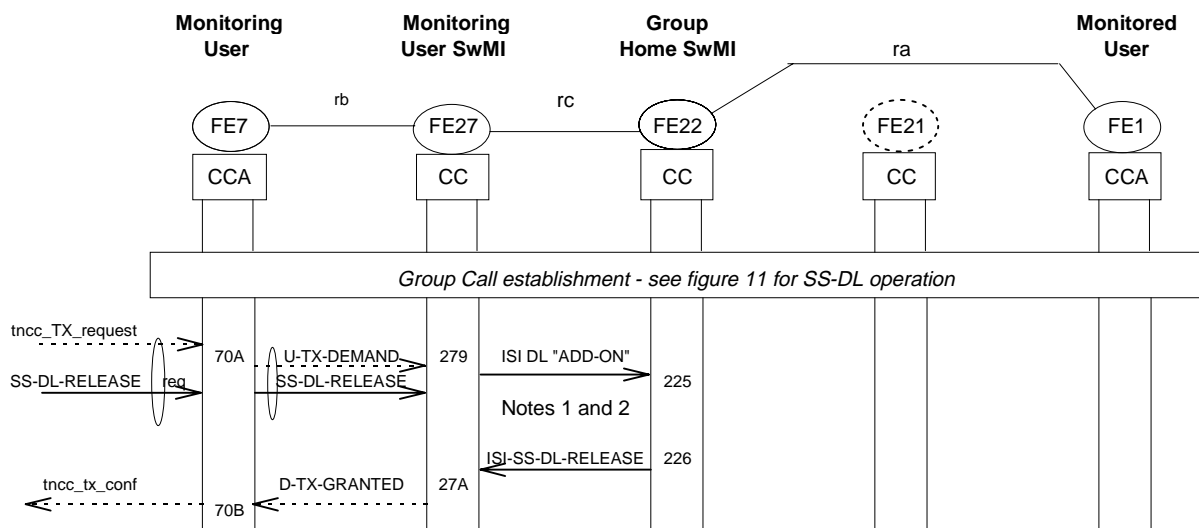

Figure 20: Operation of SS-DL information clearance of a monitored call



NOTE 1: ISI DL "ADD-ON" is actually a release of the discreet listening and a participation in the group call already set up with capability to transmit.

NOTE 2: No warning signal is given indicating call intrusion for a group call contrary to an individual call.

Figure 21: SS-DL Operation in Case of Group Call Intrusion



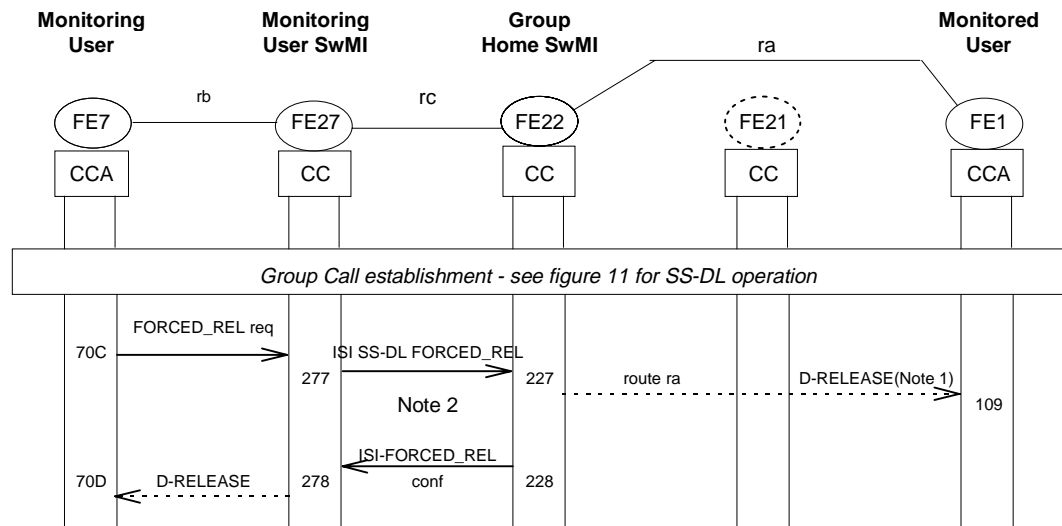

NOTE 1: Down link Release is presented to all members of the Group Call including to the Group Call Owner with a Call Clear cause indicating that the SwMI is not capable of supporting the call anymore. The release of only the single monitored user from the group call is not possible using this mechanism.

NOTE 2: SS-DL Disconnect is a special command to the SwMI in control of the group call indicating forced clear from the SS-DL monitoring/authorized user; this special command allows direct action on the group call; it avoids the need for the authorized user to become group owner (without the owner consent) and then forcefully clear the call.

Figure 22: SS-DL Operation in Case of Group Call Forced Clearing

## 6 Functional entity actions

These functional entity actions cover items presented in the previous scenarios. There may be other actions due to exceptional cases.

### 6.1 Functional Entity actions of FE1

FE1 is the monitored user; however, it is not aware of the fact that its call may be monitored. Its action 101 to 109 belongs to a basic call operation.

### 6.2 Functional Entity actions of FE21

- 211 To receive the call set up request from FE1, recognizes that FE1 belongs to the list of monitored users by FE7 and triggers an ISI-INFORM message to inform the other SwMIs of the activation of a call on that particular monitored user.
- 212 To present D-CONNECT as an acknowledgment of the U-SETUP message upon receipt of the confirmation that the INFORM message has been received to the other end of the network or after expiration of T\*.
- 213 To receive the ISI-SET-UP message, recognizes the particular nature of the call and allows the down link part of that call to be connected only. No change towards monitored user to happen.
- 214 To acknowledge receipt of ISI-SET-UP and connects through the down link.
- 215 To initiate an ISI-INFORM message to the monitoring user SwMI indicating either a call in progress or a new call with the indication that this call is an SS-DL call.
- 216 To receive the ISI-SETUP SS-DL and to recognize the particular nature of the SS-DL call allowing the monitoring user to discreet listen to the call without talking.
- 217 To generate ISI-CONNECT once the listening bridge has been set up
- 218 To either generate ISI-DISCONNECT in relation with the monitored user U-DISCONNECT without deactivating SS-DL in the case where the monitoring user has joined the call or to generate a MONITORED-CALL-CLEARED in the case where the monitoring user has not joined in the call.
- 219 To acknowledge receipt of monitored user disconnect and to present him with D-RELEASE.
- 21A To receive and to recognize an ISI-SETUP related to an ISI-CI-INV req. changing the nature of the SS-DL call into a non-discreet intrusion call.

- 21B To indicate Call Intrusion to the monitored user in a C-INTR.
- 21C To generate two related messages, one indicating ISI-CONNECT, the other indicating response to the call intrusion request.
- 21D To recognize an ISI-FORCED-REL request and to present a D-RELEASE to the monitored user.
- 21E To confirm forced release with two related messages, one indicating ISI-DISCONNECT and the other confirming forced release of the call; to keep the SS-DL active for further calls.
- 21F To generate an ISI-INFO-TALKING-ITSI to indicate which of the monitored user or the other user is talking.
- 21S To receive DL-TEMPOR-LEAVE with the ISI DISCONNECT, to discretely disconnect the monitoring user from the monitored call and to generate the ISI-RELEASE towards the monitoring user home SwMI to indicate release of the SS-DL call.
- 21T To receive MONITOR with ISI-SETUP, to connect the monitoring user to the call between the monitored user and the other user and to generate an ISI CONNECT towards the monitoring user SwMI.
- 21U To receive the U-INFO-MODIFY PDU, to recognize the change in the basic service parameters and to initiate release of the SS-DL part of the call due to that change in parameter value(s).
- 21X To receive the ISI-DISCONNECT associated with the information flow DL-TEMPOR-LEAVE , to discretely disconnect the monitoring user from the call.
- 21Y To initiate ISI-RELEASE of the SS-DL call (only the leg of the monitoring party).
- 21Z To receive the new ISI-SETUP, to recognize the special nature of the SS-DL call request associated with that particular SETUP and to generate the particular ISI-CONNECT allowing the monitoring party to listen without talking.

### 6.3 Functional Entity actions of FE7

FE7 is the authorized monitoring user.

- 701 To receive the SS-DL INFORM and delivers it to the user application as an INFORM indication.
- 702 To receive the SS-DL INFORM ACK confirmation from the user application indicating that the user has properly received the indication of a start of a new call and passes that confirmation to FE27. This confirmation allows to insure that the new call set up information has been properly received by the user application. If the confirmation is not received after a timer to be defined, the network could present INFORM to another predetermined back up user.
- 703 At any time in the call, the user application may decide to join the call; at that time FE7 to present a call set-up message with the call reference and the tele-service of the call that was presented in the INFORM content; the special nature of the call must be reported in the call set up FACILITY (indicating SS-DL call set-up) to avoid connection to FE1. MONITOR associated with U-SETUP constitutes another possible acknowledgment of the INFORM indication.
- 704 To receive the D-CONNECT indicating cut trough for the listening part of the call and to present it to the monitoring user functional entity.
- 705 To present a D-RELEASE to the monitoring user application FE7 indicating normal termination of the monitored call; SS-DL remains active.
- 706 On option, to request call intrusion into the individual call as a result of Call Intrusion request received from the FE7 user application and to generate two messages accordingly, one indicating U-SETUP and the other indicating Call Intrusion request.
- 707 To receive the D-CONNECT and the response to the call intrusion request and to present the call intrusion confirmation to the FE7 application.
- 708 On option, to initiate a forced release request for the individual/group call and to indicate that the call to be disconnected is a special SS-DL call.
- 709 On option, to receive the confirmation of the forced release of the call in a D-RELEASE message associated with a FORCED-REL conf.
- 70A To generate a transmission request to intrude into the existing group call so as to give the monitoring the talk capability.
- 70B To recognize the D-TX-GRANTED and to present it to the monitoring user application
- 70C To generate a FORCED-REL req. towards the monitoring user SwMI in reaction to the monitoring user LS/MS action.
- 70D To receive and to recognize the ISI-FORCED-REL and to present a D-RELEASE to the monitoring user acknowledgment of its forced release action.
- 70E To receive the identity of the talking user in case of individual call.
- 70F To receive the identity of any of the talking user in case of a group call.
- 70S To receive from the monitoring user application the request to temporary/permanently leave the SS-DL call, to generate a SS-DL-TEMPORARY/PERMANENT/LEAVE with the DISCONNECT basic call flow and to wait for the RELEASE of the SS-DL call.

- 70T To receive from the monitoring user application the MONITOR request, to generate a MONITOR with the SETUP basic call flow and to wait for the CONNECT.
- 70U To present to the monitoring user as a result of the associated information flow RELEASE and MODIFY, the release of the SS-DL call and the reason of that release contained in the MODIFY.
- 70X To receive the request from the monitoring user to temporarily leave the SS-DL monitored call and to present the U-DISCONNECT associated with the DL TEMPORARY LEAVE PDU.
- 70Y To receive the request from the monitoring user to join the call that it had temporarily left, to recognize the special nature of the DL-call and to present the SETUP message associated with the SS-DL information indicating the particular nature of the SETUP.

#### 6.4 Functional entity actions of FE27

- 271 To receive the ISI-INFORM message and to present to FE7 the INFORM indication.
- 272 To receive the INFORM ACK confirmation indicating that FE7 has properly received the INFORM indication and passes this message in a ISI-INFORM ACK PDU.
- 273 To receive the MONITOR associated with the U-SETUP from FE7 and to carry it to the next SwMI in an ISI-MONITOR with ISI-SETUP SS-DL to indicate the particular nature of the call set-up belonging to the SS-DL. In case of Individual Call, to present a message to indicate that the monitoring user is joining the call as a third user only to monitor the call.
- 274 To receive the ISI-CONNECT, to recognize the particular nature of the connect (no up link possibility) and to present the D-CONNECT to FE7.
- 275 On option, to receive the CI-INV req. from FE7 to provide intrusion into the individual call, to transform that request into an ISI-CI-INV request to indicate that FE7 is already involved in that call in a monitoring mode and that it now wants to talk and that only the Transmission allocation needs to be modified.
- 276 To receive ISI-CONNECT and ISI-CI-INV res. as an acknowledgment of the transmission request and to present it to FE7 as a CI-INV conf.
- 277 On option, to receive a FORCED-REL request from FE7, to recognize the particular nature of that forced clear of the call due to the SS-DL mode of operation and to generate a special message "ISI FORCED-REL" to indicate to the SwMI controlling the call to disconnect the call even if FE7 is not the owner of the call and regardless of the acceptance of the clearing by the monitored party.
- 278 To receive as an acknowledgment of the disconnect request an ISI-FORCED-REL confirmation that is presented to FE7 as a D-RELEASE indicating the end of the call that was set up with SS-DL.
- 279 To receive U-TX-DEMAND from user FE7, to recognize the request as an intrusion into an existing group call and the removal of the SS-DL discreet listening function and to allow FE7 to join in the group call.
- 27A To recognize the ISI-DL-GRANTED and to present it in a D-TX-GRANTED to user FE7.
- 27B To receive INFO-TALKING-ITSI, to recognize it and to present it to user FE7.
- 27C To receive and to recognize ISI-DISCONNECT and to present D-RELEASE to the monitoring user in the case of a normal release of an individual call.
- 27D To receive ISI-INFO-TALKING-ITSI and convert it to INFO-TALKING-ITSI towards the monitoring user FE7.
- 27S To receive the SS-DL-TEMPORARY/PERMANENT-LEAVE with U-DISCONNECT from the MS/LS, to either act on that request or to generate a SS-DL-TEMPORARY/PERMANENT with ISI-DISCONNECT towards the monitored user home SwMI.
- 27T To receive the MONITOR request with the U-SETUP, to either act on that request or to generate and ISI-MONITOR with the ISI-SETUP to inform the monitored user home SwMI that the monitoring user wishes to join the call discretely and to wait for the CONNECT.
- 27U To receive the ISI-MODIFY PDU from the monitored user SwMI, to recognize that the content of that PDU and to indicate release of the SS-DL part of the call preceded with the MODIFY reason of the RELEASE (Basic service parameters not matching).
- 27X To receive the DISCONNECT message with the associated DL-TEMPORARY-LEAVE information and to either act on it or pass it in an ISI message to the monitored user SwMI.
- 27Y To receive the SETUP request associated to SS-DL and to either act on it or present it in an ISI message to the monitored user SwMI.

**6.5 Functional entity actions of FE22**

FE22 is the SwMI controlling the group call.

- 221 On receipt of the ISI-SETUP request/indication information flow for a group call, to check if SS-DL has been activated (by the authorized user) for any member of the group. If yes, to determine whether the delivery of the identity of the talking user has been requested and to generate an ISI-INFORM message to the FE7 monitoring user SwMI.
- 222 To receive the ISI-INFORM ACK and to generate D-CONNECT at the expiration of T\*(regardless of the acceptance of the call by the monitoring user and of the receipt of INOFORM-ACK).
- 223 To receive at any time in the group call the indication that the FE7 user wishes to monitor the call in an ISI-MONITOR associated to an ISI-SETUP, to recognize the special SS-DL nature of the call and to reject any request for Transmission from the monitoring user.
- 224 Sends to FE27 the ISI-CONNECT request/indication information flow (containing SS-DL information, i.e. the GTSI, talking/sending user identity, the call reference and the tele-service).
- 225 To receive the request for intrusion into the group call and to recognize the end of the special DL situation.
- 226 After regular group call handling of transmission request, informs in ISI-D-TX GRANTED that user FE7 is allowed to talk.
- 227 To receive and to recognize the ISI-FORCED-REL req., to accept that request regardless of the ownership of the group and to release that group call with the proper indication to the participants in the group call.
- 228 To generate a confirmation of the FORCED-REL request indicating that the request has been properly handled.
- 229 To receive and to recognize the SS-DL "ADD-ON" and to remove the discreet listening for that call.
- 22A To generate an ISI-DL-GRANTED indicating that the monitoring user can now talk in the group call.
- 22B To receive U-TX-DEMAND and to inform monitoring SwMI of the identity any (not only the monitored user) of the talking user in the group call.
- 22C To grant transmission capability regardless of the monitoring user wishes to join into the call or not.

The following actions are identical to the actions in the monitored user SwMI and apply to the cases of the release of the SS-DL call in case of modify of basic service parameters and of temporary leave of the call in the case of a group call; no figure corresponds to that case which is quite similar to the case of the individual call.

- 22U To receive the U-INFO-MODIFY PDU, to recognize the change in the basic service parameters and to initiate release of the SS-DL part of the call due to that change in parameter value(s).
- 22X To receive the ISI-DISCONNECT associated with the information flow DL-TEMPOR-LEAVE , to discretely disconnect the monitoring user from the call.
- 22Y To initiate ISI-RELEASE of the SS-DL call.
- 22Z To receive the new ISI-SETUP, to recognize the special nature of the SS-DL call request associated with that particular SETUP and to generate the particular ISI-CONNECT allowing the monitoring party to listen without talking.

**6.6 Functional entity actions of FE3**

- 301 Detect the user application request for activation and send to FE20 the corresponding ACTIVATE request/indication information flow.
- 302 Deliver to the user application the information received in ACTIVATE ACK.
- 303 Detect the user application request for interrogation based on identity/identities and send to FE20 the corresponding INTERROGATE request/indication information flow.
- 304 Deliver to the user application the information received in INTERROGATE ACK.

**6.7 Functional entity actions of FE20**

- 201 On receipt of ACTIVATE, verify that the request is allowed. If the request is allowed and its parameters are valid, activate the SS-DL and send the ACTIVATE ACK information flow to FE3. If the request is not valid or authorized, return an error indication to FE3.
- 202 On receipt of INTERROGATE request/indication information flow, verify that the request is allowed and its parameters are valid. If the request is valid, fetch the SS-DL data and send it in the INTERROGATE ACK information flow to FE3. If the request is not valid or authorized, return an error indication to FE3.

## 7 Allocation of functional entities to physical equipment

The possible scenarios for the allocation of functional entities to SwMIs and MS/LSs are shown in the following tables:

- table 14 for the case of individual call;
- table 15 for the case of group call;
- table 16 for the management of SS-DL.

**Table 14: Allocation of FEs to physical equipment/SwMIs  
in the case of individual call**

FE7	FE21	FE27
MS/LS	Originating SwMI	Terminating SwMI

**Table 15: Allocation of FEs to physical equipment/SwMIs  
in the case of group call**

FE7	FE27	FE22
MS/LS	SwMI where the monitoring user is registered	Group controlling SwMI

**Table 16: Scenarios for the allocation of FEs to physical equipment/SwMIs  
in the case of management**

FE3	FE20
MS/LS	Home SwMI of monitoring user

FE20 and FE22 may be collocated. FE3 and FE7 are coincident and therefore collocated.

## 8 Inter-working considerations

The case where SS-DL extends to several TETRA networks has already been taken into account in the preceding clauses and shall be in accordance with the ETS 300 392-3-1 [6] content. The following ISI exchanges are specified in ETS 300 392-3-1 [6]:

- ISI-SETUP;
- ISI-CONNECT;
- ISI-DISCONNECT.

The following ISI exchanges are specified in stage 3 ETS 300 392-10-20 [9] document and are extension of the single entity PDUs of same name:

- ISI-INFORM;
- ISI-INFORM-ACK;
- U-SETUP-SS-DL;
- ISI-MONITORED-CALL-CLEAR;
- ISI-INFO-TALKING-ITSI;
- ISI-CI-INV;
- ISI-FORCED-REL;
- ISI-DL-ADD-ON;
- ISI-RELEASE.

As to the case of inter-working with PSTN, ISDN or GSM, it is outside the present scope of this ETS.

## History

Document history			
December 1998	Public Enquiry	PE 9914:	1998-12-04 to 1999-04-02
May 1999	Vote	V 9931:	1999-05-17 to 1999-07-30