



**E**UROPEAN  
**T**ELECOMMUNICATION  
**S**TANDARD

**DRAFT**  
pr **ETS 300 392-11-19**

October 1996

---

Source: ETSI TC-RES

Reference: DE/RES-06001-11-19

ICS: 33.020, 33.060, 33.060.50

**Key words:** TETRA, Supplementary S

**Radio Equipment and Systems (RES);  
Trans-European Trunked Radio (TETRA);  
Voice plus Data (V+D);  
Part 11: Supplementary Services (SS) Stage 2;  
Part 11-19: Barring of Incoming Calls (BIC)**

**ETSI**

European Telecommunications Standards Institute

**ETSI Secretariat**

**Postal address:** F-06921 Sophia Antipolis CEDEX - FRANCE

**Office address:** 650 Route des Lucioles - Sophia Antipolis - Valbonne - FRANCE

**X.400:** c=fr, a=atlas, p=etsi, s=secretariat - **Internet:** secretariat@etsi.fr

Tel.: +33 4 92 94 42 00 - Fax: +33 4 93 65 47 16

---

**Copyright Notification:** No part may be reproduced except as authorized by written permission. The copyright and the foregoing restriction extend to reproduction in all media.

© European Telecommunications Standards Institute 1996. All rights reserved.



## Contents

Foreword .....	5
1 Scope .....	7
2 Normative references .....	7
3 Definitions and abbreviations .....	8
3.1 Definitions .....	8
3.2 Abbreviations .....	9
4 SS-BIC stage 2 specification .....	9
4.1 Functional model .....	9
4.1.1 Functional model description .....	9
4.1.2 Description of FEs .....	10
4.1.2.1 Affected user's FE, FE1 .....	10
4.1.2.2 SS-BIC FE in SwMI, FE2 .....	11
4.1.2.3 Authorized user's FE, FE3 .....	11
4.1.2.4 SS-BIC generic FE in SwMI, FE4 .....	11
4.1.2.5 Calling party's FE, FE5 .....	11
4.2 Relationship with a basic and a packet data service .....	12
4.3 Definition of information flows .....	12
4.3.1 Definition .....	12
4.3.1.1 DEFINE .....	13
4.3.1.2 DEFINE-ACK .....	14
4.3.1.3 INFORM-USER .....	15
4.3.1.4 INFORM-USER-ACK .....	16
4.3.2 Interrogation .....	16
4.3.2.1 INTERROGATE .....	16
4.3.2.2 INTERROGATE-ACK .....	17
4.3.3 Operation .....	17
4.3.3.1 CALL-BARRED .....	18
4.4 Information flow sequences .....	19
4.4.1 Definition .....	19
4.4.2 Definition over ISI .....	20
4.4.3 Interrogation .....	20
4.4.4 Interrogation over ISI .....	21
4.4.5 Operation .....	21
4.4.6 Operation of SS-BIC when the service is barred through ISI .....	22
4.5 FE actions .....	22
4.5.1 OFE actions of FE1 .....	22
4.5.2 FE actions of FE2 .....	22
4.5.3 FE actions of FE3 .....	22
4.5.4 FE actions of FE4 .....	23
4.5.5 FE actions of FE5 .....	23
4.6 Allocation of FEs to physical equipment .....	23
4.7 Inter-working considerations .....	23
History .....	24

Blank page

## Foreword

This draft European Telecommunication Standard (ETS) has been produced by the Radio Equipment and Systems (RES) Technical Committee of the European Telecommunications Standards Institute (ETSI), and is now submitted for the Public Enquiry phase of the ETSI standards approval procedure.

This ETS is a multi-part standard and will consist of the following parts:

- Part 1: "General network design".
- Part 2: "Air Interface (AI)".
- Part 3: "Inter-working", (DE/RES-06001-3).
- Part 4: "Gateways", (DE/RES-06001-4).
- Part 5: "Terminal equipment interface", (DE/RES-06001-5).
- Part 6: "Line connected stations", (DE/RES-06001-6).
- Part 7: "Security".
- Part 8: "Management services", (DE/RES-06001-8).
- Part 9: DE/RES-06001-9, work item stopped.
- Part 10: "Supplementary Services (SS) Stage 1".
- Part 11: "Supplementary Services (SS) Stage 2".**
- Part 12: "Supplementary Services (SS) Stage 3".
- Part 13: "SDL Model of the Air Interface".
- Part 14: "PICS Proforma", (DE/RES-06001-14).

<b>Proposed transposition dates</b>	
Date of latest announcement of this ETS (doa):	3 months after ETSI publication
Date of latest publication of new National Standard or endorsement of this ETS (dop/e):	6 months after doa
Date of withdrawal of any conflicting National Standard (dow):	6 months after doa

Blank page

## 1 Scope

This European Telecommunication Standard (ETS) defines the stage 2 specification of the Supplementary Service Barring of Incoming Calls (SS-BIC) for the Trans-European Trunked Radio (TETRA) as provided by European operators.

SS-BIC enables barring restrictions for incoming services, e.g. calls, to be set. SS-BIC specifies the definition, interrogation and operation of the supplementary service. The Switching and Management Infrastructure (SwMI) applies the SS-BIC definitions when an incoming service is requested for the restricted user. The SS-BIC actions are defined for the SwMI, for the Mobile Station (MS) and for the Line Station (LS). The SS-BIC information flows may be delivered over the Inter-System Interface (ISI).

SS-BIC is invoked for incoming services within one TETRA system or for services that extend over the ISI to several TETRA systems.

Man-Machine Interface (MMI) and charging principles are outside the scope of this ETS.

Stage 2 describes the functional capabilities of the Supplementary Service introduced in stage 1 description. Stage 2 identifies the functional capabilities for the management and operation of the service in the SwMI, in the MS and in the LS. Stage 2 describes also the information flows exchanged between these entities and the flows sent over the ISI.

NOTE: The stage 2 description is followed by the stage 3 description, which specifies the encoding rules for the information flows and process behaviour for the different entities in the SwMI, in the MS and in the LS.

## 2 Normative references

This ETS incorporates, by dated or undated reference, provisions from other publications. These normative references are cited at the appropriate places in the text and the publications are listed hereafter. For dated references, subsequent amendments to or revisions of any of these publications apply to this ETS only when incorporated in it by amendment or revision. For undated references the latest edition of the publication referred to applies.

- [1] ETS 300 392-2: "Radio Equipment and Systems (RES); Trans-European Trunked Radio (TETRA); Voice plus Data (V+D); Part: 2: Air Interface (AI)".
- [2] ETS 300 392-12-19: "Radio Equipment and Systems (RES); Trans-European Trunked Radio (TETRA); Voice plus Data (V+D); Part: 12: Supplementary Services (SS) Stage 2; Part 12-19: Barring of Incoming Calls (BIC)".
- [3] ETS 300 392-10-1: "Radio Equipment and Systems (RES); Trans-European Trunked Radio (TETRA); Voice plus Data (V+D); Part: 10: Supplementary services stage 1; Part 10-1: Call diversion".
- [4] ETS 300 392-10-6: "Radio Equipment and Systems (RES); Trans-European Trunked Radio (TETRA); Voice plus Data (V+D); Part: 10: Supplementary services stage 1; Part 10-6: Call authorized by dispatcher".

### 3 Definitions and abbreviations

#### 3.1 Definitions

For the purposes of this ETS, the following definitions apply:

**affected user:** Functional Entity 1 (FE1), the user on whose behalf the incoming services are barred. SS-BIC is defined either for authorized user or for a group of which the authorized user is member.

**authorized user:** FE3, the user who is permitted to define SS-BIC on affected user's behalf.

**basic service:** Circuit mode speech service or circuit mode data service, see ETS 300 392-2 [1] clause 11.

**calling party:** FE5, the party whose service request is barred due to SS-BIC.

**Functional Entity (FE):** Functional Entity performs the SS-BIC specific tasks in the MS, in the LS or in the SwMI.

NOTE: In stage 2 specification the FE functionality is not restricted to SS sub-entity within layer 3.

**home system:** The TETRA network which Mobile Network Identity (MNI) is equal to the user's MNI. The SS-BIC definition is saved in the home system and home system is responsible for transporting the SS-BIC definition to visited system(s).

**Inter System Interface (ISI):** The interface between two TETRA networks, that enables the inter-working of services between these two systems.

**Mobile Network Identity (MNI):** Mobile Country Code (MCC) and Mobile Network Code (MNC) of the TETRA Subscriber Identity (TSI).

**Mobile Station (MS):** A physical grouping that contains all of the mobile equipment that is used to obtain TETRA services. By definition, a mobile station contains at least one Mobile Radio Stack.

**packet data service:** Connection oriented packet mode data service and connectionless packet mode data service, see ETS 300 392-2 [1] clauses 24 and 26.

**SS-BIC definition indication:** The SS-BIC definition indication may be sent to the affected user(s) to inform him about the definition made on his behalf or for a group of which he is member.

**SS-BIC operation:** The barring of a call in accordance with the SS-BIC definition.

**Switching and Management Infrastructure (SwMI):** all of the TETRA equipment for a Voice plus Data (V+D) network except for subscriber terminals. The SwMI enables subscriber terminals to communicate with each other via the SwMI.

**visited system:** The TETRA network which MNI is not equal to the user's MNI.



### 3.2 Abbreviations

For the purposes of this ETS, the following abbreviations apply:

CC	Call Control functional entity
CCA	Call Control functional entity Agent
FE	Functional Entity
ISI	Inter System Interface
LS	Line Station
MCC	Mobile Country Code
MNC	Mobile Network Code
MNI	Mobile Network Identity
MS	Mobile Station
SS-BIC	Supplementary Service Barring of Incoming Calls
SwMI	Switching and Management Infrastructure
TETRA	Trans-European Trunked Radio
V+D	Voice plus Data

## 4 SS-BIC stage 2 specification

### 4.1 Functional model

#### 4.1.1 Functional model description

The functional model shall comprise the following Functional Entities (FEs):

FE1	affected user's FE for SS-BIC in MS/LS;
FE2	SS-BIC FE in SwMI ;
FE3	authorized party's FE for SS-BIC in MS/LS;
FE4	SS-BIC generic FE for SS-BIC in SwMI in visited system;
FE5	calling party's FE for SS-BIC in MS/LS;
CC	call control functional entity in SwMI;
CCA	call control functional entity agent in MS/LS.

NOTE: CC/CCA refers to any basic service sub-entity or packet mode data service entity, which is used in conjunction with SS-BIC.

The following relationships shall exist between these FEs:

ra	between FE1 and FE2;
rb	between FE2 and FE4 in different TETRA systems;
rc	between FE2 and FE3;
rd	between FE2 and FE2 in different TETRA systems;
re	between FE1 and FE4;
rf	between FE3 and FE4;
rg	between FE2 and FE5.

Figures 1 and 2 show these FEs and their relationships. Figure 1 gives the functional model for the management part and figure 2 gives the functional model for the operational part.

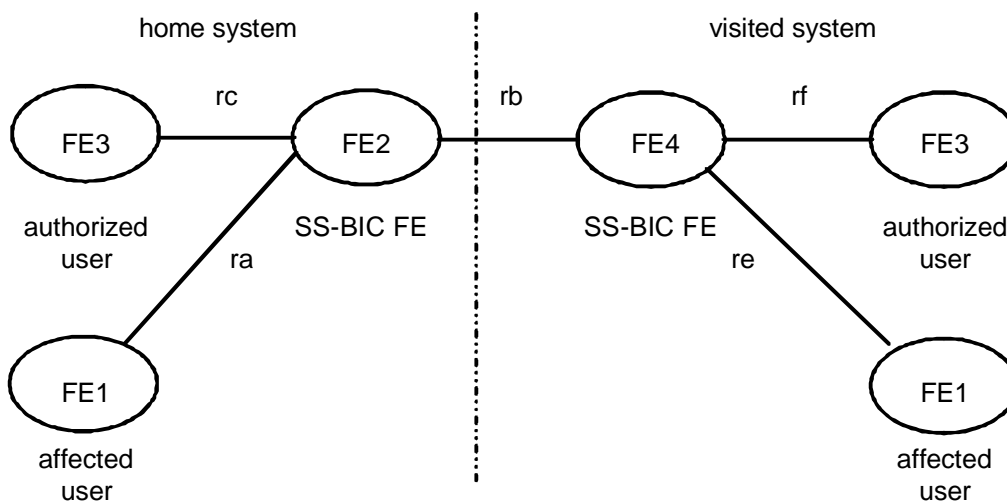
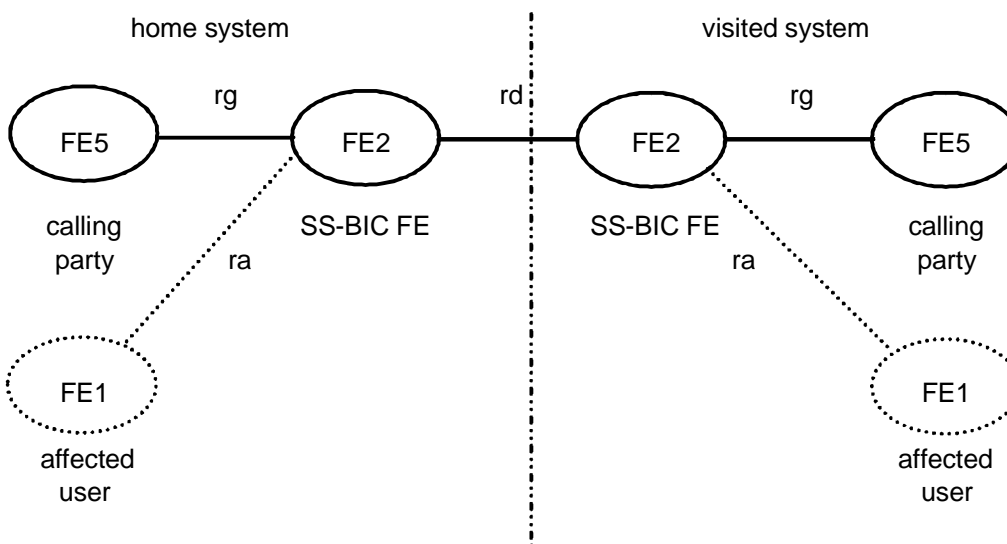

Figure 1: Functional model for the management part



NOTE: FE1 does not receive any information of the barring.

Figure 2: Functional model for the operational part

#### 4.1.2 Description of FEs

##### 4.1.2.1 Affected user's FE, FE1

Affected user is the party on whose behalf the authorized user makes the SS-BIC definition.

The functional tasks of FE1 shall be the following:

- upon reception of an SS-BIC definition indication from the SwMI, FE1 shall inform the user of the indication;
- upon reception of an SS-BIC interrogation request from the user, FE1 shall send the interrogation request to the SwMI;
- upon reception of an SS-BIC interrogation response from the SwMI, FE1 shall inform the user of the response.

**4.1.2.2 SS-BIC FE in SwMI, FE2**

The functional tasks of FE2 shall be the following in the home system of the restricted identity:

- upon reception of an SS-BIC definition request from FE3, FE2 shall save the definition in the SwMI and acknowledge the request to FE3. FE2 shall send the SS-BIC definition indication(s) to FE1(s), if requested by FE3 in the definition request;
- upon reception of an SS-BIC interrogation request from FE1 or FE3, FE2 shall send the interrogation response to FE1 or FE3 respectively;
- upon reception of an incoming basic or packet data service request to FE1, for which the SS-BIC restrictions apply, FE2 shall bar the request and inform FE5 about the barring.

The functional tasks of FE2 shall be the following in the visited system of the restricted identity:

- upon reception of an SS-BIC interrogation request from FE1 or FE3, FE2 shall send the interrogation response to FE1 or FE3 respectively, if the visited system knows the SS-BIC definition;
- upon reception of an incoming basic or packet data service request to FE1, for which the SS-BIC restrictions apply, FE2 shall bar the request and inform FE5 about the barring, if the visited system knows the SS-BIC definition;
- upon reception of an incoming basic or packet data service request to FE1, FE2 may send the service request to the home system and bar the call if indicated by the home system. FE2 shall inform FE5 about the barring of the service.

**4.1.2.3 Authorized user's FE, FE3**

The functional tasks of FE3 shall be the following:

- upon reception of an SS-BIC definition request from the user, FE3 shall send the request to the SwMI;
- upon reception of an SS-BIC definition acknowledgement from the SwMI, FE3 shall inform the user of the acknowledgement;
- upon reception of an SS-BIC interrogation request from the user, FE3 shall send the request to the SwMI;
- upon reception of an SS-BIC interrogation response from the SwMI, FE3 shall inform the user of the response.

**4.1.2.4 SS-BIC generic FE in SwMI, FE4**

As a generic functional entity for transportation, FE4 shall have perform the following tasks:

- upon reception of an SS-BIC information flow over the ISI from FE2 to FE1 or to FE3, FE4 shall transport the flow to FE1 or to FE3 respectively;
- upon reception of an SS-BIC information flow from FE1 or from FE3 to FE2, FE4 shall transport the flow over the ISI to FE2.

**4.1.2.5 Calling party's FE, FE5**

Upon reception of a barred basic or packet data service from the SwMI, FE5 shall inform the user of the barring.

#### 4.2 Relationship with a basic and a packet data service

FE2 shall be collocated to CC in the SwMI.

FE5 shall be collocated to CCA.

The relationship with basic and packet data service is shown in figure 3.

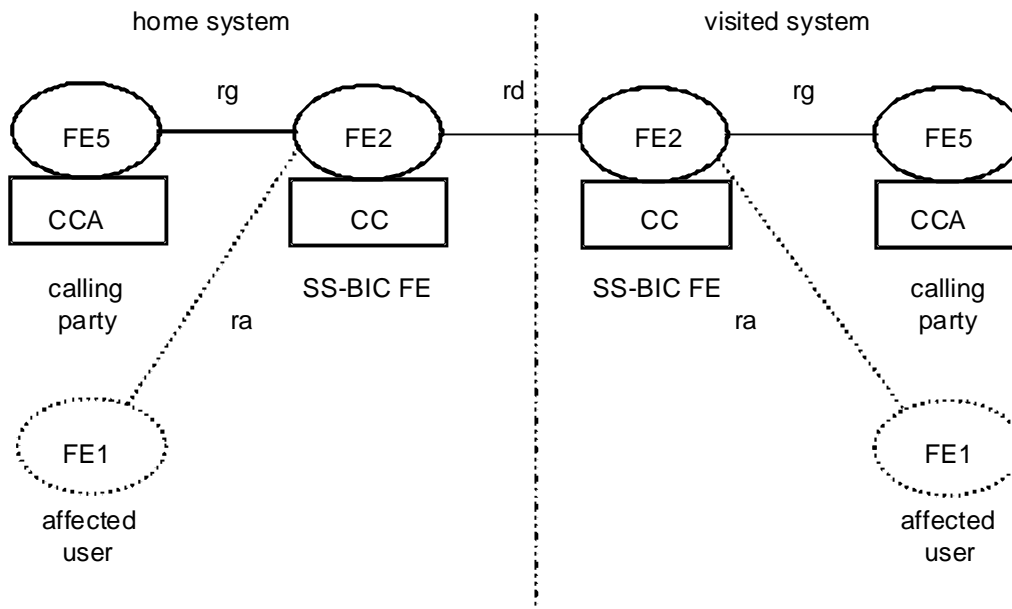

NOTE: FE1 does not receive any information of the barring.

**Figure 3: Relationships with FEs and CCs/CCAs**

#### 4.3 Definition of information flows

In the tables listing the service elements in information flows, the column header "Type" indicates which of the service elements are Mandatory (M), Conditional (C) or Optional (O). If type is conditional, the conditions are stated.

The listed service elements shall specify whether the information of each element is included in the flow.

NOTE: It is possible that there is not a one-to-one mapping between a service element and Protocol Data Unit (PDU) or primitive elements described in ETS 300 392-12-19 [2].

##### 4.3.1 Definition

The authorized user shall be able to define barring restrictions on affected user's behalf. The SS-BIC definitions shall restrict incoming services.

One restricted identity shall refer to either an individual subscriber identity or to a group identity. The authorized user shall only be allowed to define SS-BIC for subscriber identities which home system is the same as the authorized user's home system.

One definition request shall be made to restrict:

- one subscriber identity;
- a range of subscriber identities; or,
- a list of subscriber identities.

The different barring restrictions shall comprise of one or more of the following:

- all incoming services from outside a closed user group (own fleet);
- all or certain incoming service types (basic or packet data services);
- restricted source addresses for incoming services.

The authorized user may request the SwMI to send the SS-BIC definition to the affected user for information.

The SS-BIC definition made for an individual subscriber should be sent over the ISI as part of the mobility management functions, when the subscriber migrates to the system.

NOTE 1: It is possible that a TETRA system is not able to receive the SS-BIC definitions over the ISI.

NOTE 2: It is possible that a TETRA system uses other mechanisms to determine the incoming service restrictions for migrated subscribers within the system. These mechanisms are outside the scope of this ETS.

The SS-BIC definition made for a group should be sent over the ISI to each TETRA system that supports the group call when the definition is made.

NOTE 3: The SS-BIC definition of the group may be sent over the ISI as part of the mobility management function of a subscriber when the subscriber migrates to the system. The SS-BIC definition may be transported at migration e.g. if a group call is supported in a system depending on if a member of the group is located in the system.

NOTE 4: It is possible that a TETRA system is not able to receive the SS-BIC definitions over the ISI.

#### **4.3.1.1 DEFINE**

The information flow shall be applied for the relationship rc and it shall be sent from FE3 to FE2. The flow shall also be applicable for the relationship rf and rb and it shall be sent from FE3 to FE2 via FE4, if FE3 is in visited system.

If any of the given restrictions apply, the basic service is barred.

FE3 shall send the request to define SS-BIC to the SwMI for the given subscriber identity or identities.

The contents of the information flow is shown in table 1.

Table 1: DEFINE information flow

Element	Type
Defining authorized user	M
Restricted subscriber identity(ies)	M (note 1)
Incoming services outside closed user group restricted	C (note 2)
Restricted incoming service types	C (note 2), (note 3)
Restricted source address list	C (note 2), (note 4)
Exceptions to restricted source address list	O (note 5)
Definition sent to affected user(s)	O (note 6)
Acknowledgement from affected users	O (Note 7)
NOTE 1:	The element specifies the TETRA subscriber identity(ies) on which behalf the SS-BIC definition is made. One subscriber identity, a range or set of subscriber identities are given.
NOTE 2:	At least one of the following elements shall be given in the definition request: <ul style="list-style-type: none"> <li>- Incoming services outside closed user group restricted;</li> <li>- Restricted incoming service types;</li> <li>- Restricted source address list.</li> </ul>
NOTE 3:	The element indicates the restricted basic and packet data service types. Packet data service is applicable only for individual subscriber identity as a restricted basic service.
NOTE 4:	The element is a list of restricted source addresses for incoming services. A restricted address comprises of a variable-length digit string. A service requested by subscriber, which address starts with the restricted digit string, shall be barred.
NOTE 5:	The element is a list of exceptions to the restricted source addresses for incoming services. A restricted address comprises of a variable-length digit string. If the digit string for exception source address is longer than the restricted source address, the exception source address overrides and the requested service is allowed.
NOTE 6:	The element indicates if the SS-BIC definition indication is sent to the affected user(s) for information. If the restricted identity is a group, the affected users are the members of the group.
NOTE 7:	The element indicates if the affected user(s) is requested to acknowledge the reception of the definition indication.

#### 4.3.1.2 DEFINE-ACK

The information flow shall be applied for the relationship rc and shall be sent from FE2 to FE3. The flow shall also be applicable for the relationship rb and rf and it shall be sent from FE2 to FE3 via FE4, if FE3 is in visited system.

FE2 shall send the flow to acknowledge the SS-BIC definition request.

NOTE: The Definition result element does not give information whether the affected users have been successfully informed; the interrogation is used to request this, if needed.

The contents of the information flow is shown in table 2.

**Table 2: DEFINE-ACK information flow**

Element	Type
Defining authorized user	M
Restricted subscriber identity(ies)	M
Definition result	M (note)
NOTE: This element indicates the definition result: <ul style="list-style-type: none"> <li>- Defined;</li> <li>- Not defined and the applicable error code.</li> </ul>	

**4.3.1.3 INFORM-USER**

The information flow shall be applied for the relationship ra and shall be sent from FE2 to FE1. The flow shall also be applicable for the relationship rb and re and it shall be sent from FE2 to FE1 via FE4, if FE1 is in visited system.

FE2 shall send the flow to inform affected user(s) of the SS-BIC definition. FE2 shall send the information flow, if requested by the authorized user, see table 1 Definition sent to affected user(s).

The contents of the information flow is shown in table 3.

**Table 3: INFORM-USER information flow**

Element	Type
Affected user	M
Restricted subscriber identity(ies)	M (note 1)
Incoming services outside closed user group restricted	C (note 2)
Restricted incoming service types	C (note 2), (note 3)
Restricted source address list	C (note 2), (note 4)
Exceptions to restricted source address list	O (note 5)
Acknowledgement from affected users	O (Note 6)
NOTE 1: The element specifies the TETRA subscriber identity(ies) on which behalf the SS-BIC definition is made. One subscriber identity, a range or set of subscriber identities are given.	
NOTE 2: At least one of the following elements shall be given in the definition indication: <ul style="list-style-type: none"> <li>- Incoming services outside closed user group restricted;</li> <li>- Restricted incoming service types;</li> <li>- Restricted source address list.</li> </ul>	
NOTE 3: The element indicates the restricted basic and packet data service types.	
NOTE 4: The element is a list of restricted source addresses for incoming services. A restricted address comprises of a variable-length digit string. A service requested by subscriber, which address starts with the restricted digit string, shall be barred.	
NOTE 5: The element is a list of exceptions to the restricted source addresses for incoming services. A restricted address comprises of a variable-length digit string. If the digit string for exception source address is longer than the restricted source address, the exception source address overrides and the requested service is allowed.	
NOTE 6: The element indicates if the affected user(s) is requested to acknowledge the reception of the definition indication.	

**4.3.1.4 INFORM-USER-ACK**

The information flow shall be applied for the relationship ra and shall be sent from FE1 to FE2. The flow shall also be applicable for the relationship re and rb and it shall be sent from FE1 to FE2 via FE4, if FE1 is in visited system.

FE1 shall send the flow to acknowledge the reception of the SS-BIC definition indication, if the acknowledgement was requested, see table 3 Acknowledgement from affected user(s).

The contents of the information flow is shown in table 4.

**Table 4: INFORM-USER-ACK information flow**

Element	Type
Affected user	M
Restricted subscriber identity(ies)	M
Distribution result	M (note)
NOTE:	This element indicates the definition indication result: - Successfully received; - Unsuccessfully received and the applicable error code.

**4.3.2 Interrogation**

Authorized user shall be able to interrogate the SS-BIC definitions saved in the SwMI. Affected user is authorized to interrogate his own SS-BIC definitions and the SS-BIC definitions made for a group of which he is member.

If SS-BIC is interrogated in the home system of the restricted identity, the home system shall give the response to the interrogation request.

If SS-BIC is interrogated in a system that is a visited system in relation to the restricted identity, the visited system shall give the response to the interrogation request, if it has the SS-BIC definition. If a visited system does not have the SS-BIC definition or if it is otherwise not able to provide the response to the interrogation, the visited system shall send the interrogation request to the home system, which shall return the response to the visited system.

**4.3.2.1 INTERROGATE**

The information flow shall be applied for:

- the relationship ra and shall be sent from FE1 to FE2;
- the relationship rc and sent from FE3 to FE2;
- the relationship re and rb and it may be sent from FE1 to FE2 via FE4, if FE1 is in visited system;
- the relationship rf and rb and it may be sent from FE3 to FE2 via FE4, if FE3 is in visited system.

FE1 or FE3 shall send the flow to interrogate the SS-BIC definition.

The contents of the information flow is shown in table 5.

**Table 5: INTERROGATE information flow**

Element	Type
Interrogating authorized/affected user	M
Restricted subscriber identity(ies)	M (note)
NOTE:	The element specifies the TETRA subscriber identity(ies) against which SS-BIC have been interrogated.



### 4.3.2.2 INTERROGATE-ACK

The information flow shall be applied for:

- the relationship ra and shall be sent from FE2 to FE1;
- the relationship rc and sent from FE2 to FE3;
- the relationship rb and re and it may be sent from FE2 to FE1 via FE4, if FE1 is in visited system;
- the relationship rb and rf and it may be sent from FE2 to FE3 via FE4, if FE3 is in visited system.

FE2 shall send the information flow as a response to the SS-BIC interrogation.

The contents of the information flow is shown in table 6.

**Table 6: INTERROGATE-ACK information flow**

Element	Type
Interrogating authorized/affected user	M
Restricted subscriber identity(ies)	M (note 1)
Interrogation result	M (note 2)
Incoming services outside closed user group restricted	O
Restricted incoming service types	O (note 3)
Restricted source address list	O (note 4)
Exceptions to restricted source address list	O (note 5)
Definition sent to affected user(s)	O (note 6)
Acknowledgement from affected users	O (Note 7)
<p>NOTE 1: The element specifies the TETRA subscriber identity(ies) against which the SS-BIC interrogation is made. One subscriber identity, a range or set of subscriber identities are given.</p> <p>NOTE 2: This element indicates the interrogation result, for example:</p> <ul style="list-style-type: none"> <li>- SS-BIC defined for the given restricted subscriber identity(ies);</li> <li>- SS-BIC not defined for the given Restricted subscriber identity(ies);</li> <li>- Interrogation rejected and the error code.</li> </ul> <p>The optional parameters in the INFORM-ACK are only used if the Interrogation result indicates that the definition has been made to the SwMI.</p> <p>NOTE 3: The element indicates the restricted basic and packet data service types.</p> <p>NOTE 4: The element is a list of restricted source addresses for incoming services. A restricted address comprises of a variable-length digit string. A service requested by subscriber, which address starts with the restricted digit string, shall be barred.</p> <p>NOTE 5: The element is a list of exceptions to the restricted source addresses for incoming services. A restricted address comprises of a variable-length digit string. If the digit string for exception source address is longer than the restricted source address, the exception source address overrides and the requested service is allowed.</p> <p>NOTE 6: If the element is present, it indicates that the SS-BIC definition has been sent to affected user(s) for information. If the restricted identity is a group, the affected users are the members of the group.</p> <p>NOTE 7: If the element is present, the element indicates if the affected user(s) has acknowledged the distribution of the definition indication.</p>	

### 4.3.3 Operation

The SS-BIC operation occurs when FE2 bars an incoming service request on affected user's behalf. SS-BIC shall be operated due to the SS-BIC definitions made for an individual or group subscriber identity.

The SS-BIC operation shall bar services requested to an individual subscriber identity or group identity, if the requested service is in accordance with any of the restrictions in the SS-BIC definition of the identity:

- if calls requested from outside a closed user group are restricted and the calling party is outside the given user group;
- if the calling party address is restricted; or,
- if the requested service type, e.g. circuit mode speech call, is restricted.

NOTE 1: SS-BIC is not to be used to prevent certain individual subscribers from participating a group call at the call invocation or during a call; SS-BIC is used to prevent the invocation of an entire group call according to defined conditions. However, these conditions may prevent certain users from invoking the group call.

NOTE 2: Supplementary Service Call Diversion (SS-CD), ETS 300 392-10-1 [3], does not have any impact on the SS-BIC, and if the SS-BIC restrictions apply, a basic service request is barred. In other words, if SS-BIC has been defined either for the "original" or "diverted-to" called party and if the SS-BIC restrictions apply to the basic service requested to the "original" or "diverted-to" called party, respectively, the basic service is barred.

NOTE 3: Supplementary Service Call Authorized by Dispatcher (SS-CAD), ETS 300 392-10-6 [4], may be used to enable a dispatcher to allow a barred basic service to proceed.

If the SS-BIC definition is applicable to a service request, FE2 shall bar the request within the system:

- in the home system of the called subscriber identity, if FE5 is located in the system;
- locally in a visited system, if the SS-BIC definition is transported to the visited system.

NOTE 4: The visited system should have the SS-BIC definition for an individual subscriber, if the subscriber has migrated to that system.

NOTE 5: The visited system should have the SS-BIC definition for a group, if the system supports the group call.

FE2 in the home system of the restricted identity shall bar the request, if FE2 in visited system sends the service request to FE2 in the home system. FE2 in visited system cannot bar the call, if:

- FE5 is located in a system to which the SS-BIC definitions have not been transported; or,
- the system where FE5 is located does not support SS-BIC.

**4.3.3.1 CALL-BARRED**

The information flow shall be applied for the relationship rg and shall be sent from FE2 to FE5. The flow may also be applied for the relationship rd and rg and it may be sent from FE2 to FE5 via another FE2.

FE2 shall send the information flow to FE5 to indicate that the service request has been rejected due to SS-BIC.

The contents of the information flow is shown in table 7.

**Table 7: CALL-BARRED information flow**

Element	Type
Calling party	M
Called party	M
Rejection indication	M
Rejection reason (SS-BIC invoked)	M

**4.4 Information flow sequences**

Signalling procedures shall be provided in support of the information flow sequences showed below. In addition, signalling procedures shall be provided to cover other sequences arising from error situations, interactions with basic call, interactions with other supplementary services, different topologies etc.

In the figures, the SS-BIC information flows are represented by solid arrows and basic call information flows are represented by broken arrows. An ellipse embracing two information flows indicates that the two information flows occur together. Within a column representing the SS-BIC functional entity, the numbers refer to functional entity actions listed in subclause 4.5.

No timers are used in the figures.

NOTE: The information flow sequences are examples and they may not cover all possible variations of the service.

**4.4.1 Definition**

Figure 4 shows the information flow sequence for the SS-BIC definition within the home system.

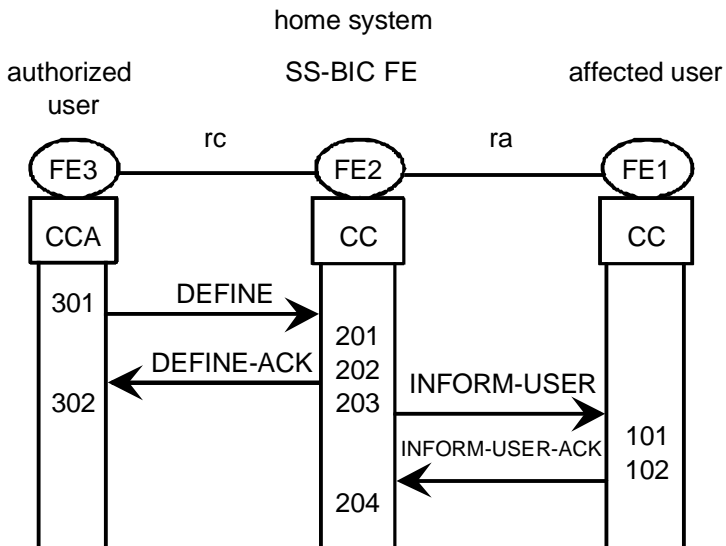

NOTE: The sending of INFORM-USER and INFORM-USER-ACK is optional.

**Figure 4: Definition of SS-BIC**

4.4.2 Definition over ISI

Figure 5 shows the information flow sequence for the SS-BIC definition requested over the ISI.

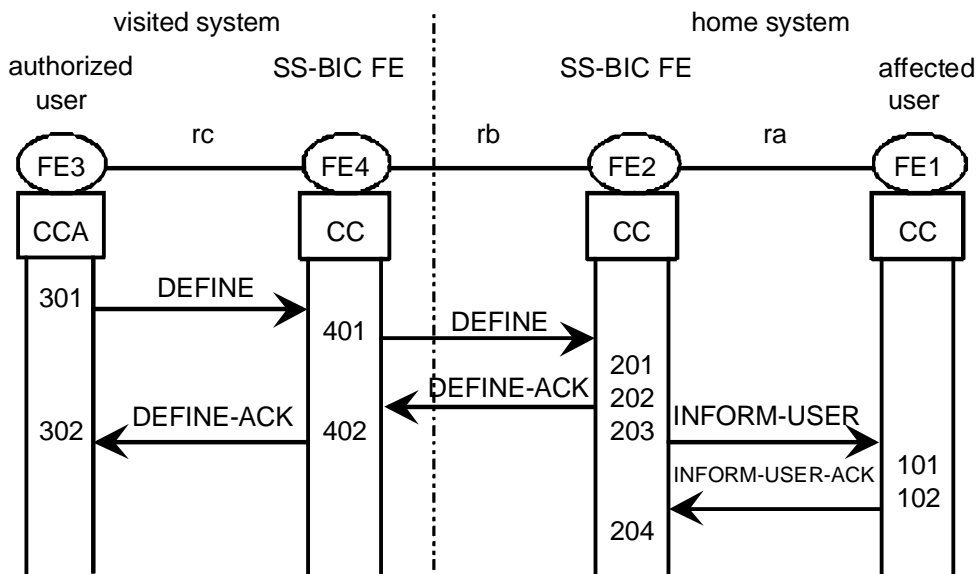

NOTE: The sending of INFORM-USER and INFORM-USER-ACK is optional.

Figure 5: Definition of SS-BIC over the ISI

4.4.3 Interrogation

Figure 6 shows the information flow sequence for the SS-BIC interrogation within the home system. Figure 6 should also be applicable for visited system to which the SS-BIC definition has been transported.

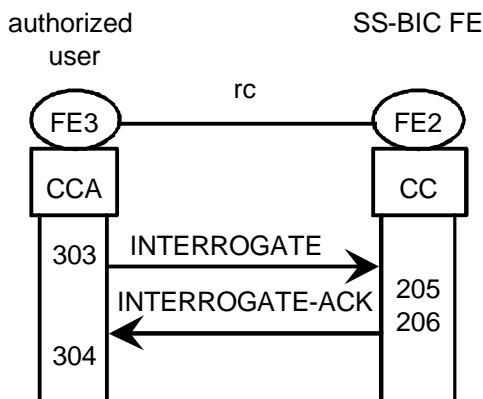

NOTE: Affected user may also interrogate SS-BIC.

Figure 6: Interrogation of SS-BIC

4.4.4 Interrogation over ISI

Figure 7 shows the information flow sequence for the SS-BIC interrogation over the ISI.

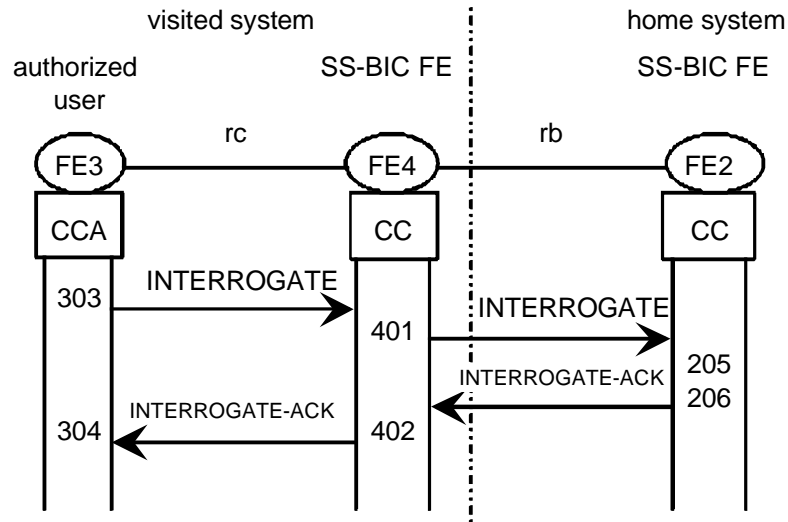

NOTE: Affected user may also interrogate SS-BIC over the ISI.

Figure 7: Interrogation of SS-BIC over the ISI

4.4.5 Operation

Figure 8 shows the information flow sequence for the SS-BIC operation within one system. The system shall be the home system or a visited system to which the SS-BIC definition has been transported.

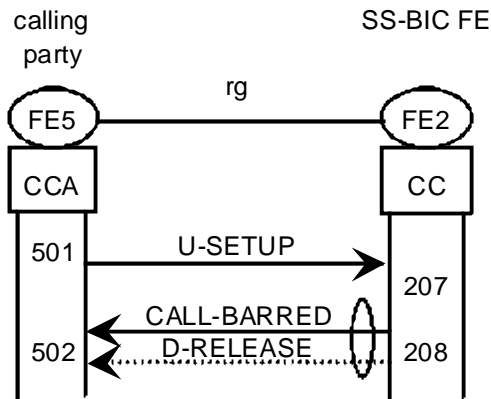

Figure 8: Operation of SS-BIC

4.4.6 Operation of SS-BIC when the service is barred through ISI

Figure 9 shows the information flow sequence for the SS-BIC operation when the service is barred through the ISI. The scenario in figure 9 applies for the visited system, that sends the service request to the home system of the restricted identity.

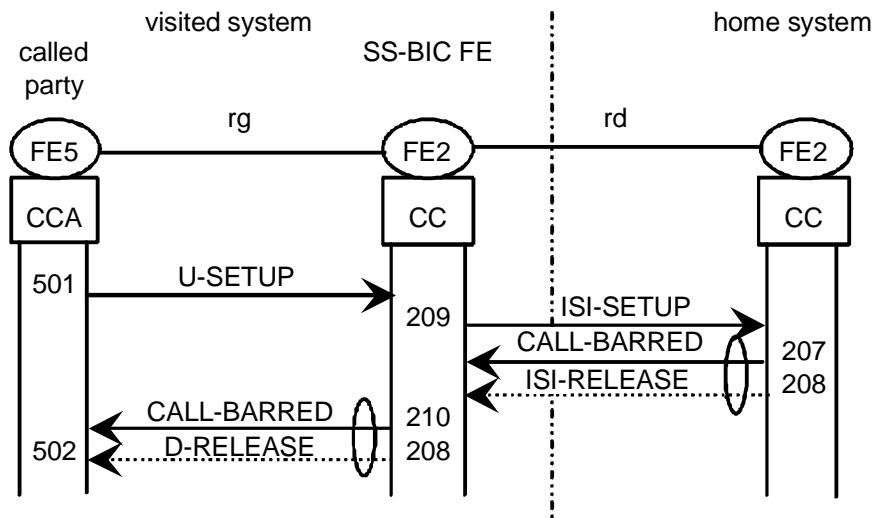

Figure 9: Operation of SS-BIC when the service is barred through the ISI

4.5 FE actions

4.5.1 OFE actions of FE1

- 101 Upon reception of the SS-BIC definition indication, FE1 shall inform the user of the indication.
- 102 FE1 shall acknowledge the SS-BIC definition indication to FE2, if the acknowledgement was requested in the indication.

4.5.2 FE actions of FE2

- 201 Upon reception of the SS-BIC definition request, FE2 shall verify that the request is authorized and parameters valid. If FE2 accepts the definition, FE2 shall save the definition into the SwMI.
- 202 FE2 shall acknowledge the definition request to FE3.
- 203 FE2 shall send the SS-BIC definition indication to FE1, if FE2 accepted the SS-BIC definition request and if FE3 requested the sending in the definition request.
- 204 Upon reception of the SS-BIC definition indication acknowledgement from FE1, FE2 shall record the acknowledgement.
- 205 Upon reception of the SS-BIC interrogation request, FE2 shall verify that the request is authorized and parameters valid.
- 206 FE2 shall send the interrogation response to FE3.
- 207 Upon reception of a service request, FE2 shall bar the request if in accordance with the SS-BIC restriction.
- 208 FE2 shall indicate the barring to FE5.
- 209 If the service request is not barred in the visited system, the request may be sent to the home system.
- 210 Upon reception of the barring indication from home system, FE2 shall bar the call.

4.5.3 FE actions of FE3

- 301 Upon reception of the SS-BIC definition request from the user, FE3 shall send the request to FE2.
- 302 Upon reception of an acknowledgement to the SS-BIC definition request from FE2, FE3 shall indicate the acknowledgement to the user.
- 303 Upon reception of the SS-BIC interrogation request from the user, FE3 shall send the request to FE2.

- 304 Upon reception of a response to the SS-BIC interrogation request from FE2, FE3 shall indicate the response to the user.

#### 4.5.4 FE actions of FE4

- 401 When FE4 receives an SS-BIC information flow from FE3, FE4 shall send the flow to FE2 in FE3's home system.
- 402 When FE4 receives an SS-BIC information flow from FE2 in FE3's home system, FE4 shall send the flow to FE3.

#### 4.5.5 FE actions of FE5

- 501 When FE5 receives a call invocation request from the user, FE5 shall send it to FE2.
- 502 Upon reception of a call invocation rejection due to SS-BIC, FE5 shall indicate the rejection reason to the user.

### 4.6 Allocation of FEs to physical equipment

The allocation of FEs to physical equipment is described in table 7.

**Table 7: Allocation of FEs to physical equipment**

FE/PE	SwMI	LS	MS
FE1	-	+	+
FE2	+	-	-
FE3	-	+	+
FE4	+	-	-
FE5	-	+	+
Key: + = applicable - = not applicable			

### 4.7 Inter-working considerations

The SS-BIC may extend to several TETRA networks. The requirements for the inter-working over the ISI are:

- deliver and receive the SS-BIC definition and interrogation information over the ISI;
- barring of requested services within the system based on the SS-BIC definitions received over the ISI;
- barring of services in the home system and indicating this to the visited system over the ISI;
- barring of services in the visited system when indicated by the home system over the ISI;
- the capability to support the generic supplementary service functions over the ISI.

## History

Document history	
October 1996	Public Enquiry PE 116: 1996-10-21 to 1997-02-14