



EUROPEAN
TELECOMMUNICATION
STANDARD

FINAL DRAFT
pr **ETS 300 392-11-11**
May 2000

Source: TETRA

Reference: DE/TETRA-03001-11-11

ICS: 33.020

Key words: Data, radio, speech, stage 2, supplementary service, TETRA

**Terrestrial Trunked Radio (TETRA);
Voice plus Data (V+D);
Part 11: Supplementary services stage 2;
Sub-part 11: Call Waiting (CW)**

ETSI

European Telecommunications Standards Institute

ETSI Secretariat

Postal address: F-06921 Sophia Antipolis CEDEX - FRANCE

Office address: 650 Route des Lucioles - Sophia Antipolis - Valbonne - FRANCE

Internet: secretariat@etsi.fr - <http://www.etsi.org>

Tel.: +33 4 92 94 42 00 - Fax: +33 4 93 65 47 16

Copyright Notification: No part may be reproduced except as authorized by written permission. The copyright and the foregoing restriction extend to reproduction in all media.

© European Telecommunications Standards Institute 2000. All rights reserved.

Contents

Foreword.....	5
1 Scope	7
2 Normative references	7
3 Definitions and abbreviations	8
3.1 Definitions	8
3.2 Abbreviations	8
4 Functional model	8
4.1 Functional model description	8
4.2 Description of functional entities	10
4.2.1 Served user functional entity, FE1	10
4.2.2 Served user SwMI functional entity, FE21	10
4.2.3 Served user new SwMI functional entity, FE21'	10
4.2.4 Affected user SwMI functional entity, FE25	10
4.2.5 Served user home SwMI FE, FE20	11
4.2.6 Affected user functional entity, FE5	11
4.3 Relationship of functional model to basic call functional model	11
5 Information flows	12
5.1 Definition of information flows	12
5.1.1 ACTIVATE	12
5.1.2 ACTIVATE ACK	12
5.1.3 DEACTIVATE	12
5.1.4 DEACTIVATE ACK	12
5.1.5 INFORM 1	13
5.1.6 INFORM 2	13
5.1.7 INVOKE	13
5.1.8 INVOCATION FAILURE	13
5.1.9 rd_LOCATION CHANGE	14
5.1.10 re_LOCATION CHANGE	15
5.2 Relationship of information flows to basic individual call information flows	15
5.3 Service primitives	16
5.4 Examples of information flow sequences	17
5.4.1 Activation	17
5.4.2 Deactivation	18
5.4.3 Invocation and operation	18
5.4.3.1 Successful invocation	18
5.4.3.2 Successful acceptance of a waiting call	19
5.4.3.3 Unsuccessful invocation	20
5.4.3.4 Migration of served user with waiting calls	21
6 FE actions	21
6.1 Functional Entity actions of FE1	21
6.2 Functional Entity actions of FE20	22
6.3 Functional Entity actions of FE21	22
6.4 Functional Entity actions of FE21'	23
6.5 Functional Entity actions of FE25	23
6.6 Functional Entity actions of FE5	23
7 Allocation of functional entities to physical equipment	24
8 Interworking considerations	24

Annex A (informative): Bibliography 26

History 27

Foreword

This final draft European Telecommunication Standard (ETS) has been produced by the Terrestrial Trunked Radio (TETRA) Project of the European Telecommunications Standards Institute (ETSI), and is now submitted for the Voting phase of the ETSI standards approval procedure.

This ETS is a multi-part standard and will consist of the following parts:

- Part 1: "General network design";
- Part 2: "Air Interface (AI)";
- Part 3: "Interworking at the Inter-System Interface (ISI)";
- Part 4: "Gateways basic operation";
- Part 5: "Peripheral Equipment Interface (PEI)";
- Part 6: "Line connected Station (LS)";
- Part 7: "Security";
- Part 9: "General requirements for supplementary services";
- Part 10: "Supplementary services stage 1";
- Part 11: "Supplementary services stage 2";**
- Part 12: "Supplementary services stage 3";
- Part 13: "SDL model of the Air Interface (AI)";
- Part 14: "Protocol Implementation Conformance Statement (PICS) proforma specification".

Proposed transposition dates	
Date of latest announcement of this ETS (doa):	3 months after ETSI publication
Date of latest publication of new National Standard or endorsement of this ETS (dop/e):	6 months after doa
Date of withdrawal of any conflicting National Standard (dow):	6 months after doa

Blank page

1 Scope

The present ETS specifies the stage 2 description of the Supplementary Service Call Waiting (SS-CW) for the Terrestrial Trunked Radio (TETRA).

SS-CW permits a called user to acknowledge an incoming individual call while he is already busy. Subsequently that user shall have the choice to accept, reject or ignore that incoming call.

Man-Machine Interface (MMI) and charging principles are outside of the scope of this ETS.

Supplementary service specifications are produced in three stages according to the method defined in CCITT Recommendation I.130 [1]. The stage 2 description identifies the functional capabilities and the information flows needed to support the supplementary service as specified in its stage 1 description (see ETS 300 392-10-11 [6]). The stage 2 description is followed by the stage 3 description, which specifies the protocols at the air interface and at the various Inter-System Interfaces (ISI) to support the service.

This document is applicable to TETRA Voice plus Data terminal equipment and networks.

2 Normative references

This ETS incorporates by dated and undated reference, provisions from other publications. These normative references are cited at the appropriate places in the text and the publications are listed hereafter. For dated references, subsequent amendments to or revisions of any of these publications apply to this ETS only when incorporated in it by amendment or revision. For undated references the latest edition of the publication referred to applies.

- [1] CCITT Recommendation I.130 (1988): "Method for the characterization of telecommunication services supported by an ISDN and network capabilities of an ISDN".
- [2] ETSI ETS 300 392-2: "Terrestrial Trunked Radio (TETRA); Voice plus Data (V+D); Part 2: Air Interface (AI)".
- [3] ETSI ETS 300 392-3-2: "Terrestrial Trunked Radio (TETRA); Voice plus Data (V+D); Part 3: Interworking at the Inter-System Interface (ISI); Sub-part 2: Additional Network Feature Individual Call (ANF-ISIIC)".
- [4] ETSI ETS 300 392-3-5: "Terrestrial Trunked Radio (TETRA); Voice plus Data (V+D); Part 3: Interworking at the Inter-System Interface (ISI); Sub-part 5: Additional Network Feature for Mobility Management (ANF-ISIMM)".
- [5] ETSI ETS 300 392-9: "Terrestrial Trunked Radio (TETRA); Voice plus Data (V+D); Part 9: General requirements for supplementary services".
- [6] ETSI ETS 300 392-10-11: "Terrestrial Trunked Radio (TETRA); Voice plus Data (V+D); Part 10: Supplementary services stage 1; Sub-part 11: Call Waiting (CW)".
- [7] ETSI ETS 300 392-12-11: "Terrestrial Trunked Radio (TETRA); Voice plus Data (V+D); Part 12: Supplementary services stage 3; Sub-part 11: Call Waiting (CW)".
- [8] ISO/IEC 11574: "Information technology - Telecommunications and information exchange between systems - Private Integrated Services Network - Circuit-mode 64 kbit/s bearer services - Service description, functional capabilities and information flows".

3 Definitions and abbreviations

3.1 Definitions

For the purposes of this ETS, the definitions of ETS 300 392-9 [5] apply with the following modifications:

affected user: calling user in an individual call.

affected user SwMI: SwMI where the affected user is currently registered. The affected user SwMI is the originating SwMI in an individual call.

served user: individual user for whom SS-CW supplementary service has been subscribed. When SS-CW has been activated for him, that user can thus successfully invoke the supplementary service for a new incoming individual call while he is already busy.

served user SwMI: SwMI where the served user is currently registered. In an individual call, the served user SwMI is the terminating SwMI.

timer T2: measures the waiting time for the offered call from user C to be either accepted or cleared by the served user B after SS-CW has been invoked. This timer is a network basic call timer. It corresponds to the basic call timer T304 on the called user side (see clause 14 of ETS 300 392-2 [2]).

3.2 Abbreviations

For the purposes of this ETS, the following general abbreviations apply:

ANF-ISIIC	Additional Network Feature - Inter-System Interface Individual Call
ANF-ISIMM	Additional Network Feature - Inter-System Interface Mobility Management
CC	Basic Service Call Control functional entity
CCA	Basic Service Call Control functional entity agent

NOTE 1: CC and CCA are applied as defined in ISO/IEC 11574 [8].

CW	Call Waiting
FE	Functional Entity
ISI	Inter-System Interface
LS	Line Station
MS	Mobile Station
SDL	Specification an Description Language
SS	Supplementary Service

NOTE 2: The abbreviation SS is only used when referring to a specific supplementary service (e.g. SS-CW).

SwMI	Switching and Management Infrastructure
------	---

4 Functional model

4.1 Functional model description

The functional model shall comprise the following Functional Entities (FEs):

FE1	Served user functional entity
FE21	Served user SwMI FE
FE21'	Served user new SwMI FE
FE25	Affected user SwMI FE
FE20	Served user home SwMI FE
FE5	Affected user FE

The following relationships shall exist:

ra	between FE1 and FE21
rb	between FE21 and FE5
rc	between FE21 and FE25
rd	between FE1 and FE21'
re	between FE21 and FE21'
rf	between FE1 and FE20

Figure 1 shows these FEs and relationships for the basic operational part of SS-CW, when the served user does not change location after he has invoked SS-CW for a (individual) call.

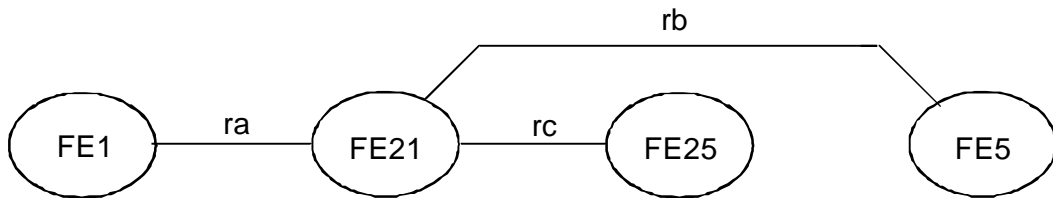

Figure 1: Functional model for the basic operational part of SS-CW

Figure 2 shows these FEs and relationships for the operational part of SS-CW when the served user changes location after he has invoked SS-CW for a (individual) call.

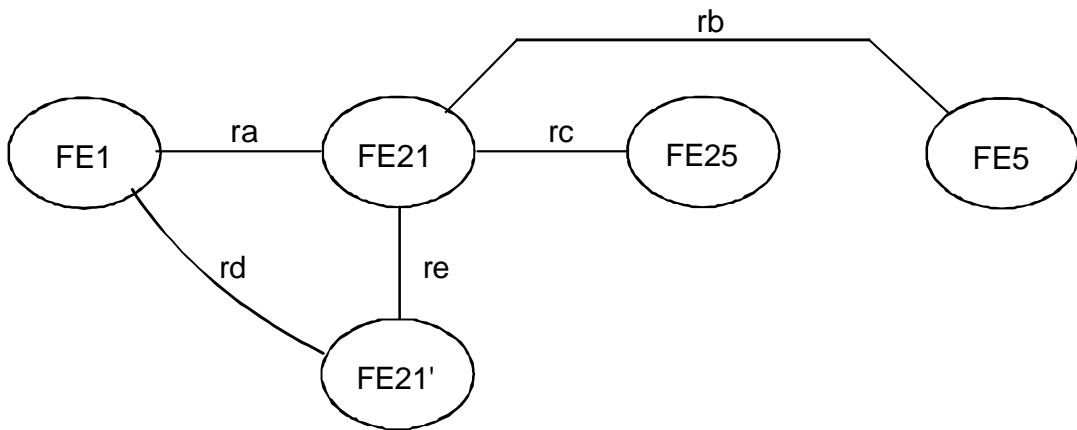
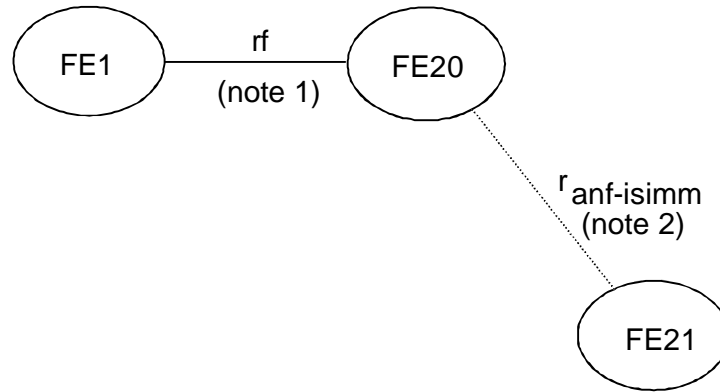

Figure 2: Functional model for the operational part of SS-CW with location change of the served user

NOTE: Both figures 1 and 2 apply only in the case of individual call since SS-CW does not apply to group call.

Figure 3 shows these FEs and relationships for the management part of SS-CW.



NOTE 1: All requests issued by the served user are to be addressed to his home SwMI.

NOTE 2: The relationship between FE20 and FE21 is an ANF-ISIMM relationship, across which the SS-CW profile is exchanged.

Figure 3: Functional model for the management part of SS-CW

4.2 Description of functional entities

4.2.1 Served user functional entity, FE1

FE1 is the functional entity that serves the called user for the invocation of SS-CW.

If the served user changes location with one or more individual call still waiting, FE1 requests FE21' about possible changes for those calls. It will process the corresponding response (from FE21') according to its contents: notably if that response indicates a call reference change for some calls still waiting, it will update accordingly its call references for those calls.

FE1 may also relay the activation and deactivation requests received from the served user to FE20, and the corresponding responses from FE20 to the served user (as indication primitives).

4.2.2 Served user SwMI functional entity, FE21

When it receives a SS-CW invocation from FE1, FE21 checks whether SS-CW has been activated and, if so, takes note that the call is waiting, in informing FE5 and FE25.

If the served user changes location with an individual call still waiting, FE21 may attempt to create FE21'. If that attempt is successful, FE21 passes the data about that call to FE21'. If not, it informs the collocated individual call control entity about the situation.

4.2.3 Served user new SwMI functional entity, FE21'

If the served user changes location with a call still waiting, FE21' may be created.

FE21' then receives the data about that call and replaces FE21 after it has answered FE1 request about possible changes for those calls (due to the location change).

4.2.4 Affected user SwMI functional entity, FE25

FE25 receives from FE21 the information that SS-CW has been invoked (by the called user) for the call and passes it to the collocated individual call control entity.

4.2.5 Served user home SwMI FE, FE20

FE20 processes the optional activation requests received from FE1.

NOTE: When the served user has migrated and is registered in a visited SwMI, the information about SS-CW activation stored by FE20 will be passed to FE21 by ANF-ISIMM (see ETS 300 392-3-5 [4]).

4.2.6 Affected user functional entity, FE5

FE5 is the functional entity that serves the affected user (i.e. the calling user) to inform him that SS-CW has been invoked (by the called user) for his call.

4.3 Relationship of functional model to basic call functional model

Although no formal model has been defined for basic individual call, that model can be readily derived from the PISN model for basic call, in ISO/IEC 11574 [8].

FE1 shall be collocated with the CCA of the called user in an individual call.

FE21 shall be collocated with the CC functional entity in the terminating SwMI.

Depending on whether the served user has roamed or migrated (with one or more individual calls still waiting), FE21' shall be collocated with the CC functional entity: either

- in the same terminating SwMI if the served user has roamed; or
- in the new terminating SwMI if the served user has migrated.

FE25 shall be collocated with the CC functional entity in the originating SwMI.

FE5 shall be collocated with the CCA of the calling user in an individual call.

Figure 4 shows the relationship between the models for SS-CW and for the basic individual call.

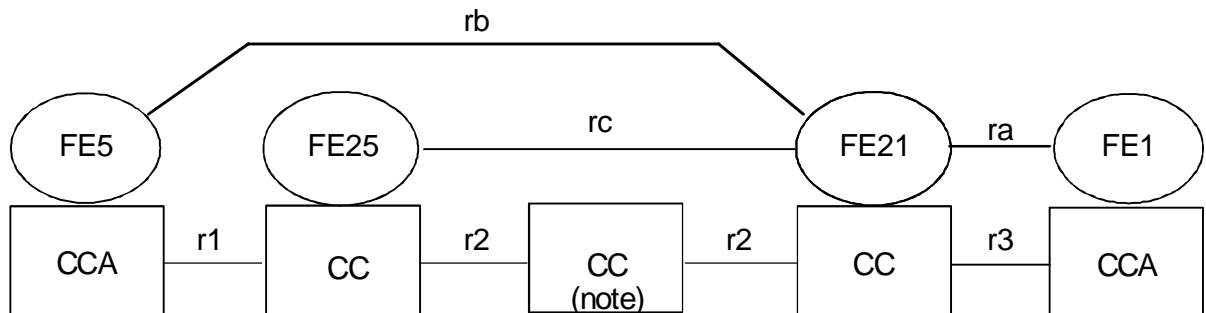

NOTE: It is possible that no intermediate CC be present (i.e. when the called user is registered in his home SwMI and when no transit Private Integrated (services) Network Exchanges -PINXs- are present).

Figure 4: Relationship between models for SS-CW and basic individual call

5 Information flows

5.1 Definition of information flows

In the tables listing the information elements in information flows, the column headed "Type" indicates which of these elements are Mandatory (M), which are Optional (O) and which are Conditional (C).

5.1.1 ACTIVATE

ACTIVATE is an unconfirmed information flow across relationship rf from FE1 to FE20 which is used to activate SS-CW.

NOTE: The response/confirmation information flow corresponding to the ACTIVATE request/indication information flow is ACTIVATE ACK (see subclause 5.1.2).

There are no elements in that information flow.

5.1.2 ACTIVATE ACK

ACTIVATE ACK is actually the response/confirmation information flow corresponding to the ACTIVATE request/indication information flow. It is thus across relationship rf from FE20 to FE1. It is used to respond to the corresponding activation request.

Table 1 lists the elements within the ACTIVATE ACK information flow.

Table 1: Contents of ACTIVATE ACK

Element	Type
Activation result	M
Activation failure cause	C (note)
NOTE: Conditional on the activation result being negative.	

The element activation result shall indicate whether the corresponding activation request has been successful or not.

The element activation failure cause shall indicate the reason why the activation request by the served user has failed. That reason may be because SS-CW has not been subscribed to for the user or because FE20 does not support the activation procedure.

5.1.3 DEACTIVATE

DEACTIVATE is an unconfirmed information flow across relationship rf from FE1 to FE20 which is used to deactivate SS-CW.

NOTE: The response/confirmation information flow corresponding to the DEACTIVATE request/indication information flow is DEACTIVATE ACK (see subclause 5.1.4).

There are no elements in that information flow.

5.1.4 DEACTIVATE ACK

DEACTIVATE ACK is actually the response/confirmation information flow corresponding to the DEACTIVATE request/indication information flow. It is thus across relationship rf from FE20 to FE1. It is used to respond to the corresponding deactivation request.

Table 2 lists the elements within the DEACTIVATE ACK information flow.

Table 2: Contents of DEACTIVATE ACK

Element	Type
Deactivation result	M
Deactivation failure cause	C (note)
NOTE: Conditional on the deactivation result being negative.	

The element deactivation result shall indicate whether the corresponding deactivation request has been successful or not.

The element deactivation failure cause shall indicate the reason why the deactivation request by the served user has failed. That reason may be because SS-CW has not been subscribed to for the user or because FE20 does not support the activation procedure.

5.1.5 INFORM 1

INFORM 1 is an unconfirmed information flow:

- across relationship rb from FE21 to FE5 to inform the affected user about the successful result of SS-CW invocation;
- across relationship rc from FE21 to FE25 to inform the originating SwMI about the successful result of SS-CW invocation.

There are no elements in that information flow.

5.1.6 INFORM 2

INFORM 2 is an unconfirmed information flow across relationship rb from FE21 to FE5 to inform the affected user that the waiting call is being cleared because the served user has changed location and either the FE21' functional entity cannot be created (e.g. case of migration into a new SwMI that does not support SS-CW) or the call control entity collocated with FE21' cannot keep "alive" the waiting call.

There are no elements in that information flow.

5.1.7 INVOKE

INVOKE is an unconfirmed information flow across relationship ra from FE1 to FE21 to invoke SS-CW.

There are no elements in that information flow.

5.1.8 INVOCATION FAILURE

INVOCATION FAILURE is an unconfirmed information flow across relationship ra from FE21 to FE1 to inform the called user who has invoked SS-CW that that invocation has failed.

Table 3 defines the content of the INVOCATION FAILURE information flow.

Table 3: Content of INVOCATION FAILURE

Element	Type
Failure cause	M

The element failure cause indicates why SS-CW failed. That cause may be that SS-CW: either

- has not been subscribed for that user; or
- has not been activated for that user.

NOTE: The above provision implies that there is a FE21 functional entity. Otherwise by definition there is no information flow INVOCATION FAILURE (since the terminating SwMI does not support SS-CW). In such a case, the called user who has invoked SS-CW will be informed about the invocation failure by the generic failure case defined in subclause 11.2.1 of ETS 300 392-9 [5].

5.1.9 rd_LOCATION CHANGE

rd_LOCATION CHANGE is a confirmed information flow across relationship rd from FE1 to FE21' in the case of location change of the served user to allow the later acceptance of the calls still waiting. The support of that information flow is optional for FE21' but mandatory for FE1 (i.e. first FE1 has to send it in case of location change of the served user with one or more calls still waiting, second if FE21' sends the corresponding response/confirmation information flow, FE1 has to receive it and act according to its information).

There are no elements in the rd_LOCATION CHANGE request/indication information flow.

Table 4 lists the elements within the rd_LOCATION CHANGE response/confirmation information flow.

Table 4: Contents of rd_LOCATION CHANGE response/confirmation

Element	Type
Location change procedure support	M
Call reference update	O (note 1)
Calls lost	O (note 2)
NOTE 1: If the location change procedure is supported (information given by the element location change procedure support): <ul style="list-style-type: none"> - may be present in the case of roaming (i.e. FE21' located in the same SwMI as FE21); - shall be present in the case of migration (i.e. FE21' located in another SwMI than FE21). 	
NOTE 2: Shall be present if the location change procedure is supported and if calls have been lost during that procedure (e.g. by lack of resources).	

The element location change procedure support shall indicate whether or not the call control entity collocated with FE21' supports the procedure for keeping "alive" calls still waiting when the served user has changed location.

NOTE: If the call control entity collocated with FE21' can keep "alive" a waiting call when the served user changes location, it will then necessarily be able to accept the later request by the served user to accept that waiting call: since the support of such request is part of TETRA basic call (the corresponding primitive is the basic service TNCC-COMPLETE request, which results in the U CONNECT PDU being sent by the served user MS).

The element call reference update shall indicate the new call references when they have changed due to the location change.

The element calls lost shall indicate the waiting calls which have been cleared during the location change procedure.

5.1.10 re_LOCATION CHANGE

re_LOCATION CHANGE is a confirmed information flow across relationship re from FE21 to FE21' in the case of location change of the served user to keep "alive" the waiting call to which it refers (so that it may be successfully accepted later). The support of that information flow is optional for both FE21 and FE21'.

NOTE 1: re_LOCATION CHANGE is over the Inter-System Interface (ISI) only when the served user changes location in registering in a new SwMI (i.e. according to TETRA terminology, the served user migrates). Otherwise, when the served user changes location within the same SwMI (i.e. according to the TETRA terminology, the served user roams), re_LOCATION CHANGE is internal to that SwMI.

Table 5 defines the content of the re_LOCATION CHANGE request/indication information flow and table 6, that of the re_LOCATION CHANGE response/confirmation information flow.

Table 5: Content of re_LOCATION CHANGE request/indication

Element	Type
Number of waiting calls	M

The element number of waiting calls shall indicate how many calls the served user has still in the call waiting state.

Table 6: Content of re_LOCATION CHANGE response/confirmation

Element	Type
Location change support	M

The element location change support shall indicate whether or not the call control entity collocated with FE21' can keep "alive" the waiting call to which the re_LOCATION CHANGE response/confirmation information flow refers.

NOTE 2: See note in subclause 5.1.9.

5.2 Relationship of information flows to basic individual call information flows

Table 7 shows the relationship of the SS-CW information flows to those of basic individual call over both the air interface and the ISI.

NOTE: The basic individual call information flows are defined:

- for the air interface, if not explicitly in ETS 300 392-2 [2], at least implicitly in clause 11 and 14 of that ETS; and
- for the ISI, in ETS 300 392-3-2 [3].

Table 7: Relationship of SS-CW information flows to basic call

Information flow	Independent of basic call?	With basic call?	Basic call flows:
INFORM 1	no	yes	D-ALERT (note 2)
INFORM 2	no	yes	D-RELEASE (note 3)
ACTIVATE	yes (note 1)	no	
ACTIVATE ACK	yes (note 1)	no	
DEACTIVATE	yes (note 1)	no	
DEACTIVATE ACK	yes (note 1)	no	
INVOCATION FAILURE	yes	yes	note 4
INVOKE	no	yes	U-ALERT
rd_LOCATION CHANGE request/indication	yes (note 1)	no	
rd_LOCATION CHANGE response/confirmation	yes (note 1)	no	
re_LOCATION CHANGE request/indication	no	yes	CALL RESTORE PREPARE request/indication (note 5)
re_LOCATION CHANGE response/confirmation	no	yes	CALL RESTORE PREPARE response/confirmation (note 5)
NOTE 1:	This information flow is not only independent of basic call, but call unrelated.		
NOTE 2:	In addition if the call is over the ISI (i.e. the terminating SwMI is different from the originating SwMI), INFORM 1 is sent together with the ANF-ISIIC SETUP response/confirmation information flow corresponding to on/off hook signalling (which translates into the ANF-ISIIC ALERTING PDU in the corresponding protocol).		
NOTE 3:	In addition if the call is over the ISI (i.e. the terminating SwMI is different from the originating SwMI), INFORM 2 is sent together with the ANF-ISIIC RELEASE information flow.		
NOTE 4:	INVOCATION FAILURE is sent across relationship ra: either - independently of any basic call information flow if the call control entity collocated with FE21 did not know that the served user was busy when it has send the SETUP request/indication information flow; or - together with the air interface RELEASE request/indication information flow, otherwise.		
NOTE 5:	The CALL RESTORE PREPARE request/indication and response/confirmation information flows are ISI basic individual call information flows only when the served user changes location in registering in a new SwMI (i.e. the served user migrates). The CALL RESTORE PREPARE request/indication information flow is then sent together with the PISN SETUP request/indication information flow. If that information flow is successful, the corresponding CALL RESTORE PREPARE response/confirmation information flow is sent together with the PISN SETUP response/confirmation information flow (the PISN SETUP response/confirmation information flow translates into the PSS1 CONNECT message in the corresponding protocol). If that information flow is unsuccessful, the corresponding CALL RESTORE PREPARE response/confirmation information flow is sent together with the PISN RELEASE request/indication information flow. When the served user changes location within the same SwMI with a call still waiting (i.e. the served user roams), the CALL RESTORE PREPARE request/indication and response/confirmation information flows remain internal to that SwMI.		

5.3 Service primitives

This subclause lists SS-CW service primitives used to invoke or being a result of information flow sequences. The SS-CW service primitives are defined in ETS 300 392-12-11 [7], subclause 5.4.

The SS-CW service primitives for the served user at the MS/LS TNSS-SAP shall be:

- ACTIVATE request;
- ACTIVATE ACK indication;
- DEACTIVATE request;
- DEACTIVATE ACK indication;
- INVOKE request;
- INVOCATION FAILURE indication.

NOTE: There are no LOCATION CHANGE primitives, because the corresponding information flows across relationship rd are not exchanged with the user application (but only with FE1).

The SS-CW service primitives for the affected user at the MS/LS TNSS-SAP shall be:

- INFORM 1 indication;
- INFORM 2 indication.

5.4 Examples of information flow sequences

ETS 300 392-12-11 [7], on SS-CW stage 3 description, specifies the signalling procedures in support of the information flow sequences specified in the following subclauses. In addition, it specifies signalling procedures to cover other sequences arising from error situations, interactions with basic call, interactions with other supplementary services, different topologies etc.

In the figures, SS-CW information flows are represented by solid arrows and basic call information flows are represented by broken arrows. An ellipse embracing two information flows indicates that the two information flows occur together. Within a column representing an SS-CW functional entity, the numbers refer to functional entity actions listed in clause 6.

5.4.1 Activation

Figure 5 shows the information flow sequence for the operation of SS-CW activation.

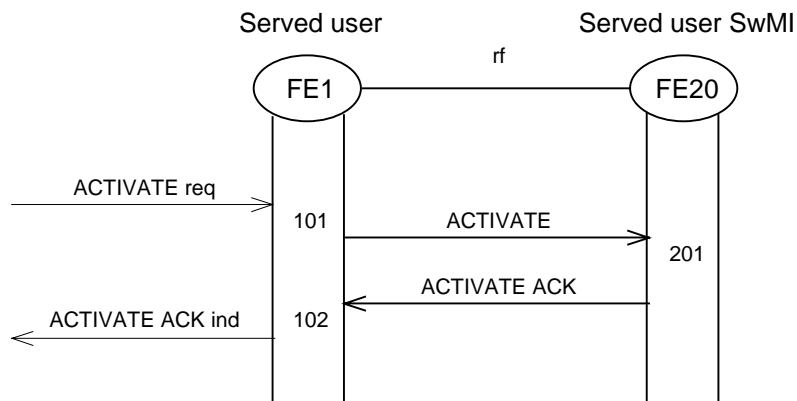

Figure 5: Activation of SS-CW

5.4.2 Deactivation

Figure 6 shows the information flow sequence for the successful operation of SS-CW deactivation.

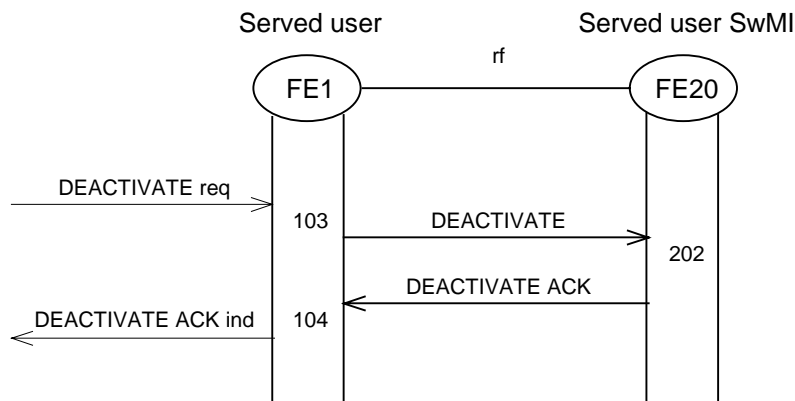

Figure 6: Deactivation of SS-CW

5.4.3 Invocation and operation

5.4.3.1 Successful invocation

Figure 7 shows the information flow sequence for the successful SS-CW invocation.

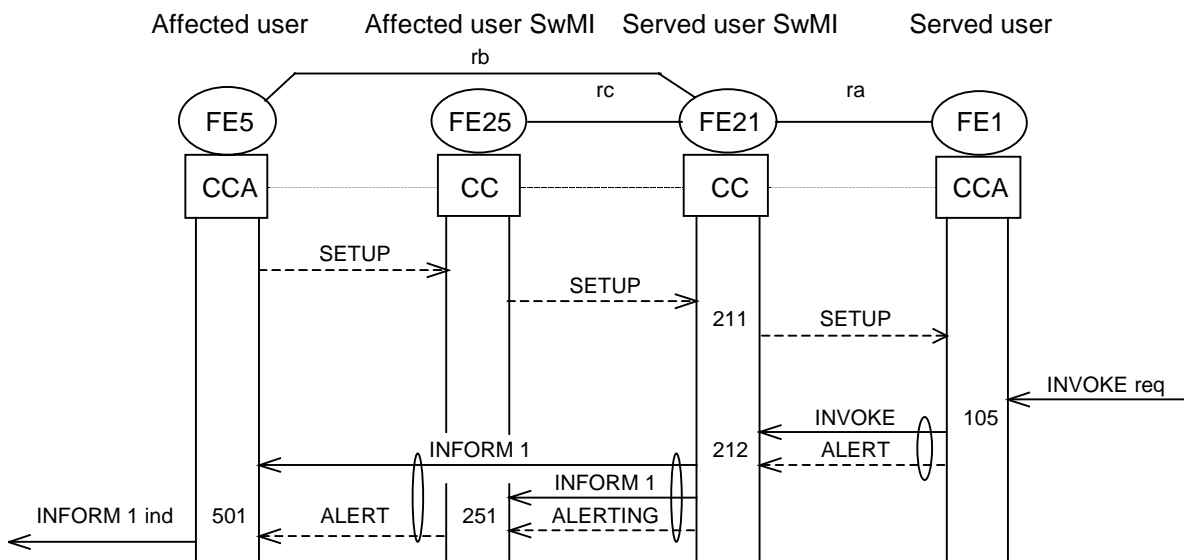
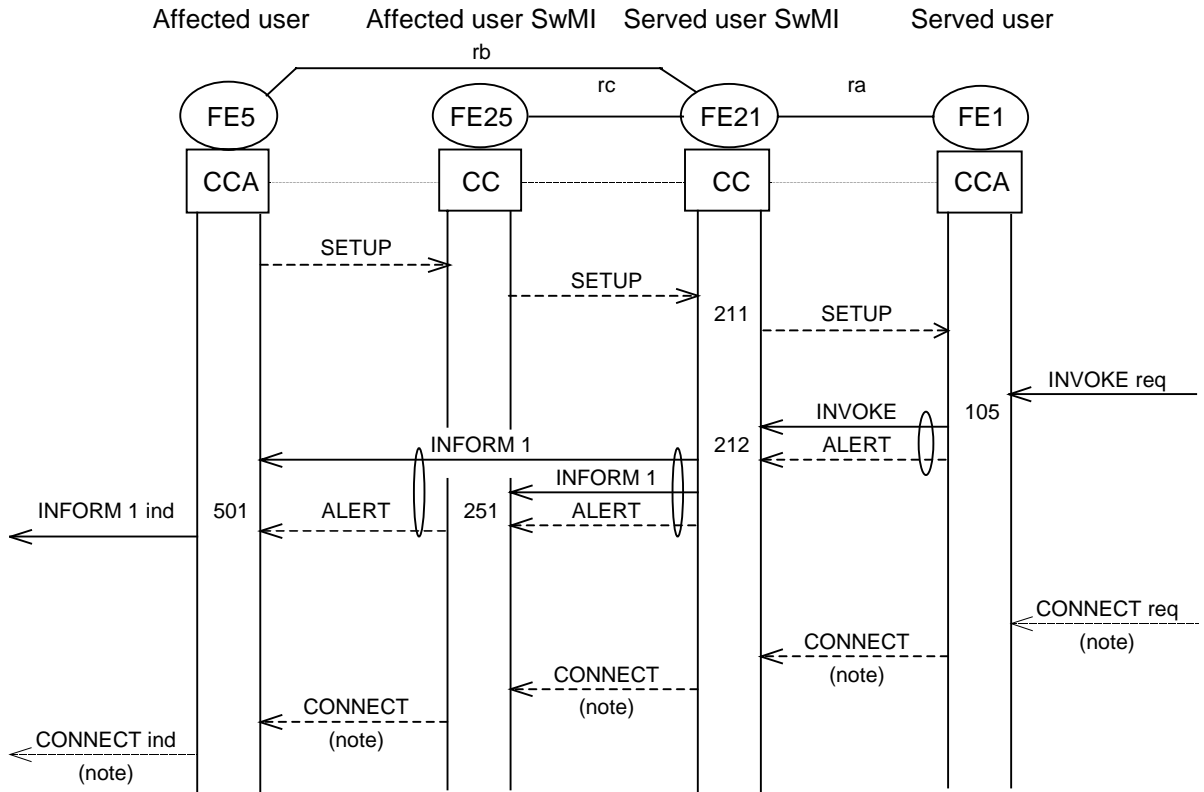

Figure 7: Successful invocation

5.4.3.2 Successful acceptance of a waiting call

Figure 8 develops figure 7 in showing the basic call SETUP response/confirmation information flow for the successful acceptance of a waiting call.



NOTE 1: For easier understanding the basic call SETUP response/confirmation information flow which corresponds to the acceptance of the call waiting has been given the name of the corresponding protocol PDU and PISN message.

NOTE 2: There is no SS-CW information flow sequence in the case of unsuccessful acceptance of the waiting call, because the corresponding failure case is a basic call case.

Figure 8: Successful acceptance of a waiting call

5.4.3.3 Unsuccessful invocation

Figure 9 shows the information flow sequence for the unsuccessful SS-CW invocation in the case where the establishment of the call continues.

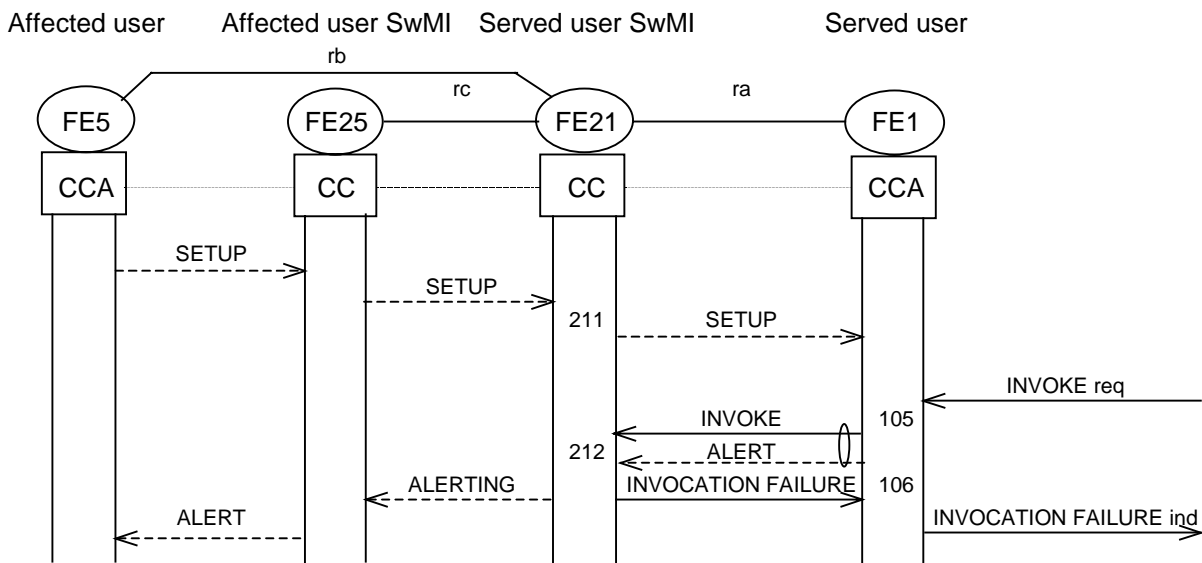

Figure 9: Unsuccessful invocation - call continues

Figure 10 shows the information flow sequence for the unsuccessful SS-CW invocation in the case where the call is cleared.

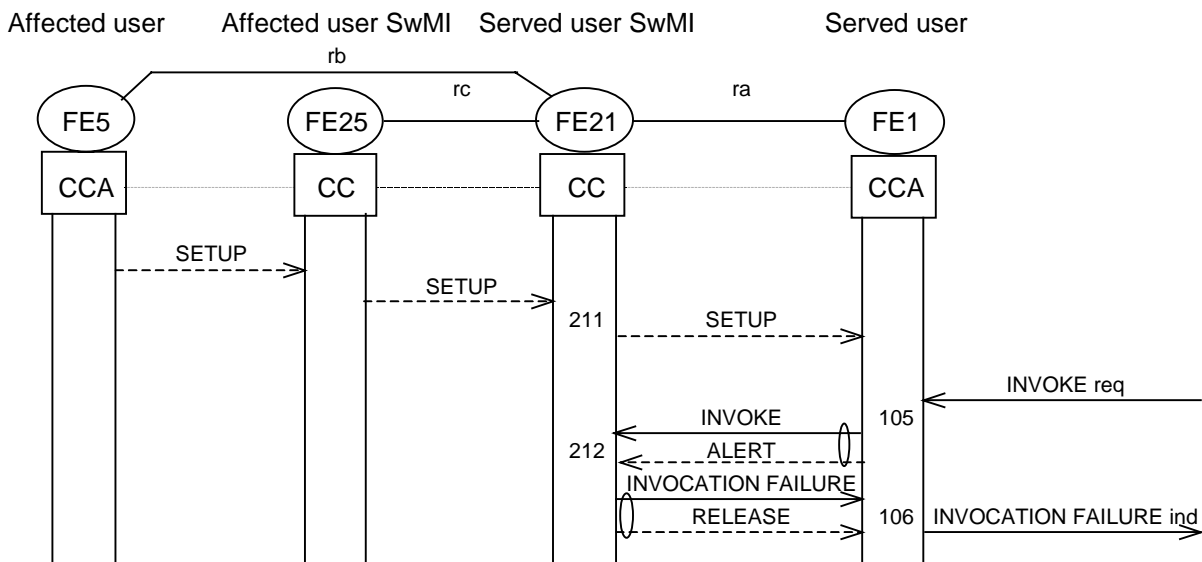

Figure 10: Unsuccessful invocation - call is cleared

5.4.3.4 Migration of served user with waiting calls

Figure 11 shows the information flow sequence for the successful migration of the served user with one or more waiting calls.

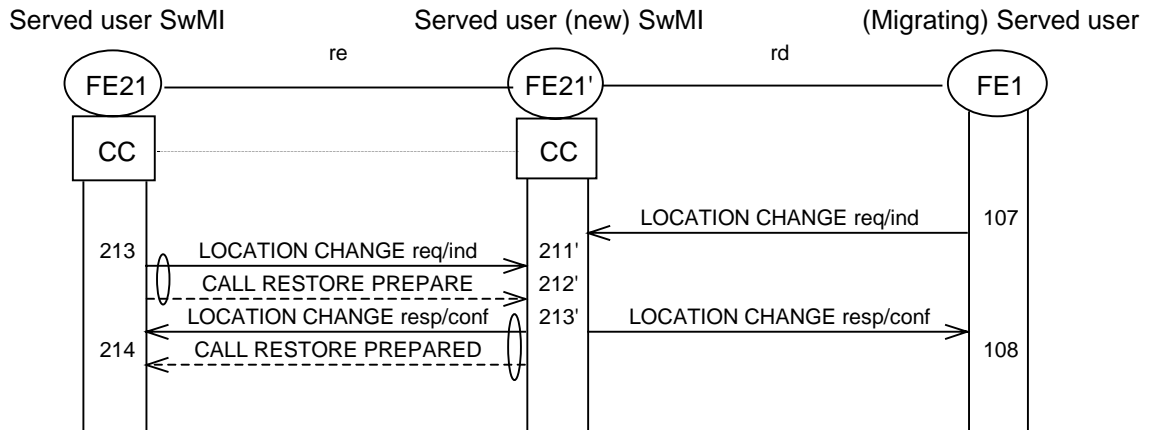

Figure 11: Successful migration of served user with waiting calls

Figure 12 shows the information flow sequence for the unsuccessful migration of the served user with one or more waiting calls in the case where the call control entity collocated with FE21' cannot keep "alive" such waiting calls (when the served user has changed location).

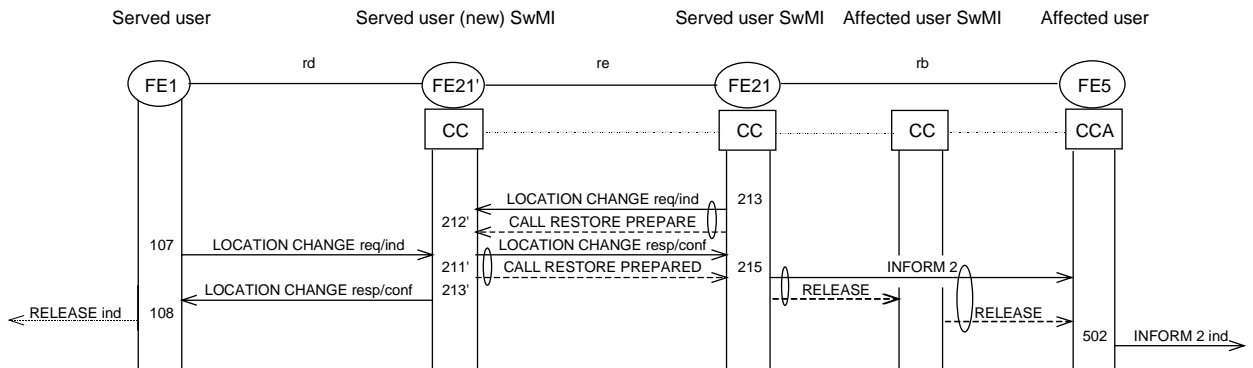

Figure 12: Unsuccessful migration of served user with waiting calls

6 FE actions

These functional entity actions cover items presented in the previous scenarios. There may be other actions due to exceptional cases.

6.1 Functional Entity actions of FE1

- 101 Receive the user application request for activation and send to FE20 the corresponding ACTIVATE request/indication information flow.
- 102 Receive the ACTIVATE ACK request/indication information from FE20 and deliver its information to the user application.
If the ACTIVATE ACK request/indication information flow indicates that the request has failed because FE20 does not support the (optional) activation procedure, consider nevertheless that SS-CW has been activated for the served user.
- 103 Receive the user application request for deactivation and send to FE20 the corresponding DEACTIVATE request/indication information flow.

- 104 Receive the DEACTIVATE ACK request/indication information flow from FE20 and deliver its information to the user application.
If the DEACTIVATE ACK request/indication information flow indicates that the request has failed because FE20 does not support the (optional) deactivation procedure, consider that SS-CW has not been deactivated for the served user.
- 105 Receive the SS-CW invocation request from the user application and send to FE21 the corresponding INVOKE request/indication information flow.
Except for special applications, if the initial value of the basic call timer T304 (see *(new version of)* clause 14 of ETS 300 392-2 [2]) is less than 30 seconds, FE1 should extend it at least to 30 seconds.
- 106 Receive the INVOCATION FAILURE request/indication information flow from FE21 and deliver its information to the user application.
- 107 Send the rd_LOCATION CHANGE request/indication information flow to FE21' whenever the served user changes location (i.e. roams or migrates) and wait for the rd_LOCATION CHANGE response/confirmation information flow.
- 108 Receive the rd_LOCATION CHANGE response/confirmation information flow from FE21' and update accordingly the call references of the calls waiting and/or clear the waiting calls lost during the location change process.

6.2 Functional Entity actions of FE20

- 201 On receipt of ACTIVATE request/indication information flow, verify that SS-CW has been subscribed to for the served user. If yes, activate that supplementary service. Acknowledge that action in sending back in the ACTIVATE ACK request/indication information flow to FE1. If SS-CW has not been subscribed to for the requesting user return an error indication to FE1.
- 202 On receipt of DEACTIVATE request/indication information flow, verify that SS-CW has been subscribed to for the served user. If yes, deactivate that supplementary service. Acknowledge that action in sending back in the DEACTIVATE ACK request/indication information flow to FE1. If SS-CW has not been subscribed to for the requesting user return an error indication to FE1.

6.3 Functional Entity actions of FE21

- 211 Check if SS-CW has been activated for the served user.
If yes ensure that the collocated individual call control entity offers new incoming calls to the served user even when that user is busy as long as the maximum number of calls still waiting for that user has not already been reached.
If SS-CW has not been activated for the served user, possibly ensure that the collocated individual call control entity does not offer new incoming calls to that user when it knows that he is busy.
- 212 Receive the INVOKE request/indication information flow if sent by FE1. Check if SS-CW has been activated for the served user.
If yes, put the call in the call waiting state,. Except for special applications, if the initial value of timer T2 is less than 30 seconds, FE21 should extend it at least to 30 seconds. Inform both the affected user and the affected user SwMI about the situation in sending to FE5 and FE25 the INFORM 1 request/indication information flow together with the basic call SETUP response/confirmation information flow (which translates into the D-ALERT PDU in the corresponding air interface protocol and into the ISI-ALERTING in the corresponding ISI protocol if the call is over the ISI).
If SS-CW has not been activated for the served user, reject the INVOKE request/indication information flow from FE1 in sending to it the INVOCATION FAILURE request/indication information flow.
- 213 When informed that the served user has changed location, optionally request the collocated ANF-ISIIC control entity to send the ANF-ISIIC-CALL RESTORE request/indication information flow for each call still waiting and send to FE21' together with this information flow the re_LOCATION CHANGE request/indication information flow. Then wait for receiving the corresponding re_LOCATION CHANGE response/confirmation information flow from FE21'.

- 214 Receive the corresponding re_LOCATION CHANGE response/confirmation information flow from FE21'. If it indicates that the call control entity collocated with FE21' can keep "alive" the waiting call to which the re_LOCATION CHANGE information flows refers, instruct the collocated ANF-ISIIC control entity to cut through the user information channel, i.e. the traffic channel, by forward switching and to become transparent to the PSS1 signalling (i.e. so that the old served user SwMI operates now simply as a transit node or set of nodes).
- 215 If either FE21 does not support the SS-CW location change procedure or the re_LOCATION CHANGE response/confirmation information flow (from FE21') indicates that the call control entity with which FE21' is collocated cannot keep "alive" the waiting call to which it refers, clear the call in sending the INFORM 2 request/indication information flow to FE5. Do the same if the ANF-ISIIC timer for receiving the ANF-ISIIC-CALL RESTORE PREPARE response/confirmation information flow with which the response to the re_LOCATION CHANGE request/indication information flow is to be received (see table 7) has expired and that ANF-ISIIC-CALL RESTORE PREPARE response/confirmation information flow has not been received yet.

6.4 Functional Entity actions of FE21'

- 211' Receive the rd_LOCATION CHANGE request/indication information flow from FE1. If not yet having received all the re_LOCATION CHANGE request/indication information flows from FE21, wait for receiving them in starting timer Tloc_change.
- 212' Receive the re_LOCATION CHANGE request/indication information flow from FE21. Respond in sending the re_LOCATION CHANGE response/confirmation information flow.
- 213' After having received the rd_LOCATION CHANGE request/indication information flow from FE1 (see action 211') and either when having received the re_LOCATION CHANGE request/indication information flows for all calls waiting (for the served user), or upon expiry of timer Tloc_change, send the rd_LOCATION CHANGE response/confirmation information flow to FE21. Take over FE21 role for each waiting call for which it has received the re_LOCATION CHANGE request/indication information flow and answered it in indicating in the corresponding re_LOCATION CHANGE response/confirmation information flow that the call control entity with which it is collocated can keep "alive" that waiting call (after the served user has changed location).

NOTE: See note in subclause 5.1.9.

6.5 Functional Entity actions of FE25

- 251 Receive the INFORM 1 request/indication information flow from FE21 and pass its information to the collocated individual call control entity (i.e. that the called user has invoked SS-CW for the call from the affected user).

NOTE 1: That collocated individual call control entity may use that information to save radio resources at the calling user MS air interface as long the call is waiting.

NOTE 2: In addition, if the originating SwMI is different from the terminating SwMI, that collocated individual call control entity should extend the call time-out, set-up phase, as indicated in the basic call ANF-ISIIC SETUP response/confirmation information flow - received from the terminating SwMI, which translates into the ISI-ALERTING in the corresponding ISI protocol.

6.6 Functional Entity actions of FE5

- 501 Receive the INFORM 1 request/indication information flow from FE21 and pass its information to the user application (i.e. that the called user has invoked SS-CW for the call from the affected user).
- 502 Receive the INFORM 2 request/indication information flow from FE21 and pass its information to the user application (i.e. that the waiting call from the affected user is cleared because the optional SS-CW procedure of location change of the served user is not supported by FE21 or by FE21').

7 Allocation of functional entities to physical equipment

The allocations of functional entities to SwMIs and MS/LSs shall be:

- as shown in table 8, in the case of SS-CW invocation and operation during an individual call;
- as shown in table 9, in the case of activation.

Table 8: Scenarios for the allocation of FEs to physical equipment/SwMI and MS/LSs in the case of invocation and operation during an individual call

	FE1	FE21	FE21'	FE25	FE5
Scenario 1	Called user MS/LS	Terminating SwMI	-	Originating SwMI	Calling user MS/LS
Scenario 2	Called user MS	Terminating SwMI	Same terminating SwMI (note 1)	Originating SwMI	Calling user MS/LS
Scenario 3	Called user MS	Terminating SwMI	New terminating SwMI (note 2)	Originating SwMI	Calling user MS/LS
Scenario 4	Called user MS/LS	Terminating SwMI	-	Incoming gateway	External calling user
Scenario 5	Called user MS	Terminating SwMI	Same terminating SwMI (note 1)	Incoming gateway	External calling user
Scenario 6	Called user MS	Terminating SwMI	New terminating SwMI (note 2)	Incoming gateway	External calling user
Scenario 7	External called user	Outgoing gateway	-	Originating SwMI	Calling user MS/LS
NOTE 1: Case of roaming, i.e. within the same terminating SwMI, and where that SwMI supports the SS-CW location change procedure.					
NOTE 2: Case of migration, i.e. into a new terminating SwMI, and where that SwMI supports the SS-CW location change procedure.					

Table 9: Scenario for the allocation of FEs to physical equipment/SwMI and MS/LS in the case of activation

	FE1	FE20
Scenario 1	Served user MS/LS	Served user home SwMI

8 Interworking considerations

The case where SS-CW extends to several TETRA networks has already been taken into account in the preceding clauses, except for the exchange of information related to the support, the subscription and the activation of SS-CW. Such exchange occurs when:

- a subscriber migrates into a SwMI different from his home SwMI; or
- the SS-CW activation state is modified.

As defined in ETS 300 392-3-5 [4], such exchange is ensured:

- in the first case (i.e. when the subscriber migrates into a SwMI different from his home SwMI): by
 - the ANF-ISIMM PROFILE UPDATE request/indication information flow, which contains the information whether SS-CW has been subscribed to for the subscriber (which implies that SS-CW is supported by the concerned MS). If so, the corresponding ANF-ISIMM PROFILE UPDATE response/confirmation information flow contains the information whether SS-CW is supported by the visited SwMI; followed by
 - the ANF-ISIMM SS-PROFILE UPDATE request/indication information flows, containing the SS-CW activation state, itself followed by the corresponding response/confirmation.

- in the second case, subject to SS-CW being subscribed to for the subscriber and supported by his visited SwMI, only by the ANF-ISIMM SS-PROFILE UPDATE request/indication information flows, containing the SS-CW activation state, itself followed by the corresponding response/confirmation.

More precisely, the information about the SS-CW subscription is carried by the sub-element SS-information in the element individual basic migration profile in the ANF-ISIMM PROFILE UPDATE request/indication information flow, while the response about the SS-CW support by the visited SwMI is carried by the sub-element SS-information response in the element individual basic migration profile in the ANF-ISIMM PROFILE UPDATE response/confirmation information flow.

Normally, when SS-CW has been subscribed to for a subscriber and is supported by his visited SwMI, his home SwMI shall download to the visited SwMI:

- the SS-CW activation state when that subscriber (i.e. the served user) migrates in that SwMI;
- every modification of that SS-CW activation state made while that subscriber remains in that (same) SwMI.

The sub-sub-element SS status of the above mentioned sub-element SS-information shall then take the value corresponding to SS-CW subscribed to with SS-migration profile.

The downloading of a SS-CW activation state by the home SwMI to the visited SwMI shall be done using the (ANF-ISIMM) sub-element SS-migration profile (original) in the ANF-ISIMM SS-PROFILE UPDATE request/indication information flow. Table 10 defines the SS-CW information which shall then be included in the (ANF-ISIMM) sub-sub-element SS-ISI-PROFILE (original) of that sub-element SS-migration profile (original).

Table 10: SS-CW information in (ANF-ISIMM) SS-ISI-PROFILE (original)

Sub-element	Type
Activation state	M

The element activation state shall indicate whether the SS-CW has been activated or deactivated.

In the case of a (external incoming) call from an external user, SS-CW shall apply as specified for calls between TETRA users, except for the information flows INFORM 1 and 2 if they cannot be extended to the external user by the external network. In that case, FE5 shall be allocated to the gateway with the external network for the corresponding INFORM information flows.

If the call waiting supplementary service is available to the external user in the other network, and if that user invokes it for an individual call from a TETRA user, the TETRA gateway may extend the INFORM information flows for that external supplementary services to the TETRA user in translating those information flows into the TETRA SS-CW INFORM 1 or 2.

Annex A (informative): Bibliography

The following material, though not specifically referenced in the body of the present document (or not publicly available), gives supporting information.

- ETS 300 392-1: "Terrestrial Trunked Radio (TETRA); Voice plus Data (V+D); Part 1: General network design".

History

Document history	
September 1999	Public Enquiry PE 9958: 1999-09-08 to 2000-01-07
May 2000	Vote V 20000707: 2000-05-08 to 2000-07-07