

EUROPEAN
TELECOMMUNICATION
STANDARD

DRAFT
pr **ETS 300 392-11-08**

December 1999

Source: TETRA

Reference: DE/TETRA-03001-11-08

ICS: 33.020

Key words: TETRA, V+D, data, radio, speech, stage 2, supplementary service, area select

**Terrestrial Trunked Radio (TETRA);
Voice plus Data (V+D);
Part 11: Supplementary services stage 2;
Sub-part 8: Area Selection (AS)**

ETSI

European Telecommunications Standards Institute

ETSI Secretariat

Postal address: F-06921 Sophia Antipolis CEDEX - FRANCE

Office address: 650 Route des Lucioles - Sophia Antipolis - Valbonne - FRANCE

Internet: secretariat@etsi.fr - <http://www.etsi.org>

Tel.: +33 4 92 94 42 00 - Fax: +33 4 93 65 47 16

Copyright Notification: No part may be reproduced except as authorized by written permission. The copyright and the foregoing restriction extend to reproduction in all media.

© European Telecommunications Standards Institute 1999. All rights reserved.

Contents

Foreword	5
1 Scope	7
2 Normative references	7
3 Definitions and Abbreviation.....	8
3.1 Definitions	8
3.2 Abbreviations	8
3.2.1 General abbreviations	8
4 Functional model.....	9
4.1 Functional model description	9
4.2 Description of functional entities	11
4.2.1 Served user functional entity, FE1.....	11
4.2.2 Served user current SwMI functional entity, FE21	11
4.2.3 Area number mapping functional entity, FE221	11
4.2.4 SS-AS operation controlling functional entity, FE222.....	11
4.2.5 SS-AS operating functional entity, FE25	11
4.2.6 Managed served user/group home SwMI FE, FE20	12
4.2.7 Authorized user functional entity, FE3.....	12
4.3 Relationship of functional model to basic call functional model.....	12
5 Information flows	15
5.1 Definition of information flows	15
5.1.1 ASSIGN	15
5.1.2 ASSIGN ACK	16
5.1.3 DEFINE	16
5.1.4 DEFINE ACK.....	17
5.1.5 INTERROGATE	17
5.1.6 INTERROGATE ACK.....	18
5.1.7 INVOKE	19
5.1.8 INVOKE CONFIRM.....	19
5.1.9 INVOKE EXT	20
5.1.10 NOT DEFINED	20
5.1.11 NOT SUBSCRIBED	21
5.1.12 NOT SUPPORTED	21
5.2 Relationship of information flows to basic call information flows	21
5.3 Service primitives.....	23
5.4 Examples of information flow sequences	23
5.4.1 Definition	24
5.4.1.1 Definition with no assignment.....	24
5.4.1.2 Definition with assignment.....	24
5.4.2 Interrogation	25
5.4.3 Invocation and operation	25
5.4.3.1 Invocation for individual call with successful operation.....	25
5.4.3.1.1 Successful call establishment.....	25
5.4.3.1.2 Call attempt cleared by SS-AS	28
5.4.3.2 Invocation for group call with successful operation	29
5.4.3.2.1 Successful call establishment.....	29
5.4.3.2.2 Call attempt cleared by SS-AS	33
5.4.3.3 Operation for call restoration	34
5.4.3.4 SS-AS invocation failure	34
5.4.3.4.1 Group call attempt by calling user outside the selected area with SS-AS inhibition for that user.....	34
5.4.3.4.2 Selected area not defined.....	35

	5.4.3.4.3	SS-AS not supported.....	36
	5.4.3.4.4	SS-AS not subscribed to	37
6	FE actions.....		37
6.1	Functional Entity actions of FE1		37
6.2	Functional Entity actions of FE20.....		37
6.3	Functional Entity actions of FE21		38
6.4	Functional Entity actions of FE221.....		38
6.5	Functional Entity actions of FE222.....		39
6.6	Functional Entity actions of FE25.....		40
6.7	Functional Entity actions of FE3.....		41
7	Allocation of functional entities to physical equipment.....		42
8	Interworking considerations		43
	History.....		45

Foreword

This draft European Telecommunication Standard (ETS) has been produced by the Radio Equipment and Systems (RES) Technical Committee of the European Telecommunications Standards Institute (ETSI), and is now submitted for the Public Enquiry phase of the ETSI standards approval procedure.

The present document is a multi-part standard and will consist of the following parts:

- Part 1: "General network design".
- Part 2: "Air Interface (AI)".
- Part 3: "Inter-working", (DE/RES-06001-3).
- Part 4: "Gateways", (DE/RES-06001-4).
- Part 5: "Terminal equipment interface", (DE/RES-06001-5).
- Part 6: "Line connected stations", (DE/RES-06001-6).
- Part 7: "Security".
- Part 8: "Management services", (DE/RES-06001-8).
- Part 9: "Performance objectives", (DE/RES-06001-9).
- Part 10: "Supplementary Services (SS) Stage 1".
- Part 11: "Supplementary Services (SS) Stage 2", (DE/RES-06001-11).**
- Part 12: "Supplementary Services (SS) Stage 3", (DE/RES-06001-12).
- Part 13: "SDL Model of the Air Interface", (DE/RES-06001-13).
- Part 14: "PICS Proforma", (DE/RES-06001-14).
- Part 15: "Interworking - Extended Operations", (DE/RES-06001-15).
- Part 16: "Gateways for Supplementary Services", (DE/RES-06001-16).

Proposed transposition dates	
Date of latest announcement of this ETS (doa):	3 months after ETSI publication
Date of latest publication of new National Standard or endorsement of this ETS (dop/e):	6 months after doa
Date of withdrawal of any conflicting National Standard (dow):	6 months after doa

Blank page

1 Scope

The present document specifies the stage 2 description of the Supplementary Service Area Selection (SS-AS) for the Terrestrial Trunked Radio (TETRA).

SS-AS enables a user to select an area where a call will be set up.

Man-Machine Interface (MMI) and charging principles are outside of the scope of the present document.

Supplementary service specifications are produced in three stage according to the method defined in ITU-T Recommendation I.130 [1]. The stage 2 description identifies the functional capabilities and the information flows needed to support the supplementary service as specified in its stage 1 description (see ETS 300 392-10-8 [8]). The stage 2 description is followed by the stage 3 description, which specifies the protocols at the air interface and at the various Inter-System Interfaces (ISI) to support the service.

The present document is applicable to TETRA Voice plus Data terminal equipment and networks.

2 Normative references

The present document incorporates, by dated or undated reference, provisions from other publications. These normative references are cited at the appropriate places in the text and the publications are listed hereafter. For dated references, subsequent amendments to or revisions of any of these publications apply to the present document only when incorporated in it by amendment or revision. For undated references the latest edition of the publication referred to applies.

- [1] ITU-T Recommendation I.130 (1988): "Method for the characterization of telecommunication services supported by an ISDN and network capabilities of an ISDN".
- [2] ETS 300 392-1: "Terrestrial Trunked Radio (TETRA); Voice plus Data (V+D); Part 1: General network design".
- [3] ETS 300 392-2: "Terrestrial Trunked Radio (TETRA); Voice plus Data (V+D); Part 2: Air Interface (AI)".
- [4] ETS 300 392-3-2: "Radio Equipment and Systems (RES); Trans-European Trunked Radio (TETRA); Voice plus Data (V+D); ANF-ISIIC
- [5] ETS 300 392-3-3: "Radio Equipment and Systems (RES); Trans-European Trunked Radio (TETRA); Voice plus Data (V+D); ANF-ISIGC
- [6] ETS 300 392-3-5: "Radio Equipment and Systems (RES); Trans-European Trunked Radio (TETRA); Voice plus Data (V+D); ANF-ISIMM
- [7] ETS 300 392-9: "Terrestrial Trunked Radio (TETRA); Voice plus Data (V+D); Part 9: General requirements for supplementary services".
- [8] ETS 300 392-10-8: "Terrestrial Trunked Radio (TETRA); Voice plus Data (V+D); Part 10: Supplementary services stage 1; Sub-part 8: Area selection".
- [9] ETS 300 392-12-8: "Terrestrial Trunked Radio (TETRA); Voice plus Data (V+D); Part 12: Supplementary services stage 3; Sub-part 8: Area Selection (AS)".
- [10] ISO/IEC 11574: "Information technology; Telecommunications and information exchange between systems; Private Integrated Services Network; Circuit-mode 64 kbit/s bearer services; Service description, functional capabilities and information flows".

3 Definitions and Abbreviation

3.1 Definitions

For the purposes of the present document, the definitions of ETS 300 392-9 [7] apply with the following modifications:

authorized user: An identified user who is allowed to define areas and/or interrogate the infrastructure about the SS-AS areas defined for an individual subscriber or for a group.

served user: The calling party who invokes the supplementary service when setting up a group call or an individual call.

served user SwMI: SwMI where the served user is currently registered. In a call (whether an individual or a group call), the served user SwMI is the originating SwMI.

In addition, the following definitions shall apply:

geographical definition: Definition of an SS-AS area given by limits on a map. In practice, due to the difficulty to describe mathematically any area shape, only circles, areas along a line and rectangular areas are specified in SS-AS protocol (see ETS 300 392-12-8 [9]).

important user: In a group call, a user considered by the group controlling SwMI as being important. In the case of SS-AS, this definition applies also to the calling user of a group call (i.e. even if the group controlling SwMI does not consider that user as being important).

site definition: Definition of an SS-AS area given as a list of base stations within one or more SwMIs. Such list may be implicit, e.g. area defined as a whole home SwMI with no visited SwMI (i.e. no participating SwMI in the case of a group call, and no other terminating SwMI than such home SwMI in the case of an individual call).

3.2 Abbreviations

3.2.1 General abbreviations

For the purposes of the present document, the following general abbreviations apply:

ANF-ISIMM	Additional Network Feature - Inter-System Interface Mobility Management
AS	Area Selection
CC	Basic Service Call Control functional entity
CCA	Basic Service Call Control functional entity agent

NOTE: CC and CCA are applied as defined in ISO/IEC 11574 [8].

FE	Functional Entity
GTSI	Group TETRA Subscriber Identity
ISI	Inter-System Interface
ITSI	Individual TETRA Subscriber Identity
LS	Line Station
MS	Mobile Station
SS	Supplementary Service

NOTE: The abbreviation SS is only used when referring to a specific supplementary service (e.g. SS-AS).

SwMI	Switching and Management Infrastructure
------	---

4 Functional model

4.1 Functional model description

The functional model shall comprise the following Functional Entities (FEs):

FE1	Served user functional entity;
FE21	Served user current SwMI FE;
FE221	Area number mapping FE;
FE222	SS-AS operation controlling FE;
FE25	SS-AS operating FE;
FE20	Managed served user/group home SwMI FE;
FE3	Authorized user functional entity.

The following relationships shall exist between these FEs:

ra	between FE1 and FE21;
rb	between FE21 and FE221;
rc	between FE221 and FE222;
rd	between FE222 and FE25;
re	between FE1 and FE221;
rf	between FE1 and FE222;
rg	between FE3 and FE20.

Figure 1 shows these FEs and relationships for the basic operational part of SS-AS.

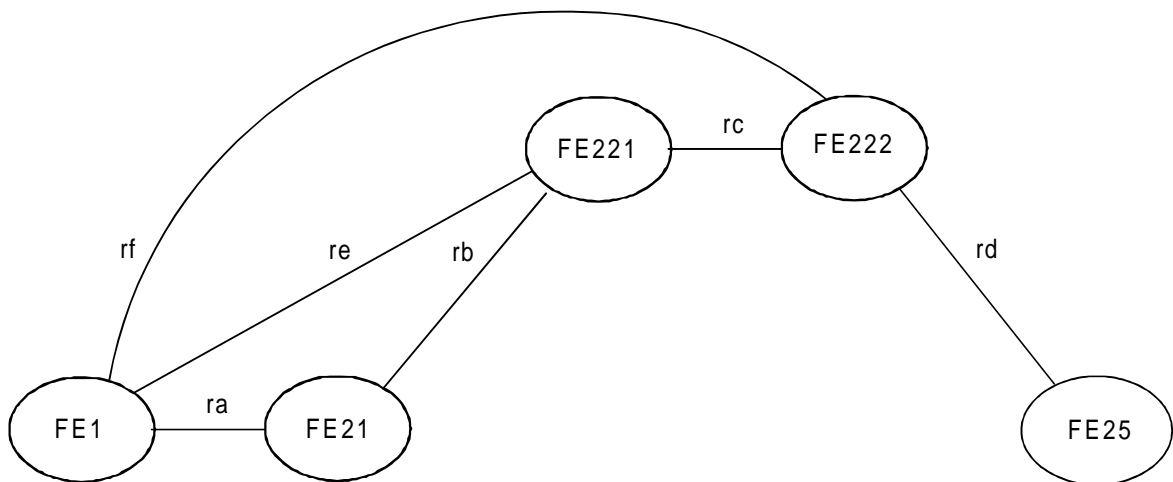

Figure 1: Functional model for the operational part of SS-AS

NOTE: No functional entity is shown for the called users because the only SS-AS related action for users participating in the group call is to inform them when they fail to restore their call (after having changed location) because of SS-AS operation (i.e. they have moved outside the selected area and either they are not important users for the call or SS-AS operation has not been inhibited for such users). Such information being delivered to the user call control entity, the corresponding actions are to be considered as basic call actions and not as SS-AS actions (hence the absence of SS-AS functional entity for the called users).

Explanation about figure 1

FE25 shall check whether it can establish the call within the selected area requested. It shall be located;

- in the case of an individual call, in the terminating SwMI;
- in the case of a group call, in:
 - the group controlling SwMI (for the group members attached to the group in that SwMI or because it can determine that some participating SwMIs -where group members are attached- are totally outside the selected area);
 - the participating SwMIs partly outside the selected area.

In the case of a group call, both FE221 and FE221 shall be located in the group controlling SwMI when the selected area is one defined for the group - i.e. per GTSI. FE221 shall be located in the originating SwMI (assuming that the latter is different from the former), for the determination of the area corresponding to the area number sent by FE1, and FE222, in the group controlling SwMI for SS-AS operation control, when the selected area is one defined for the calling user - i.e. per ITSI.

In the case of an individual call, FE221 shall be located in: either

- the originating SwMI (FE221 shall then be co-located with FE21, in which case the relationship rb will "collapse"); or
- the called user home SwMI.

FE222 shall be located in the called user home SwMI. If the -individual- call is then established by rerouting, the protocol for sending the SS-AS information flow over relationship rc actually relays it through the originating SwMI - but such relaying is a stage 3 description issue and not to be taken into account in the stage 2 description.

Figure 2 shows these FEs and relationships for the management part of SS-AS.

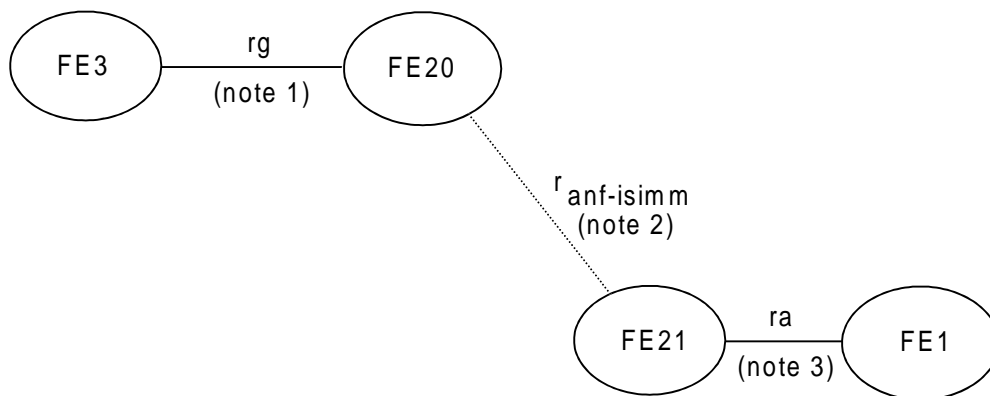

NOTE 1: All requests issued by the authorized user for an SS-AS managed served user or group are to be addressed to the home SwMI of this managed served user or group.

This holds even if the calling user is given a partial authorized user capability to define selectable areas against his ITSI, or place interrogation about such definition.

NOTE 2: The relationship between FE20 and FE21 is an ANF-ISIMM relationship, across which flows the SS-AS profile exchange.

NOTE 3: The relationship ra is shown on the figure in case the definition is assigned (i.e. downloaded) to the served user.

Figure 2: Functional model for the management part of SS-AS

4.2 Description of functional entities

4.2.1 Served user functional entity, FE1

FE1 is the functional entity that serves the calling user for the invocation of SS-AS.

In addition, FE1 handles the reception of the area definitions from FE21 and the possible sending of their acknowledgement to FE21.

4.2.2 Served user current SwMI functional entity, FE21

When it receives an SS-AS invocation from FE1 (at call set-up time), FE21 determines if SS-AS has been activated (i.e. subscribed) for the group, in the case of a group call, or for the served user, in the case of an individual call.

NOTE: Actually, there is one exception to the checking by FE21 of SS-AS subscription for the group: in the case where the group is not attached. This is because the corresponding protocol would have slowed down the establishment of the group call.

In addition in the case of group call, FE21 informs FE22 whether an FE25 collocated with it (see subclause 4.2.4) would support the inhibition of SS-AS operation for the calling user at the establishment of the call (so that that user can participate in the group call if he is outside the selected area).

In addition, if instructed by FE20, FE21 downloads the SS-AS definitions (received as part of ANF-ISIMM - see ETS 300 392-3-5 [6]) and receives the possible corresponding acknowledgements from FE1.

4.2.3 Area number mapping functional entity, FE221

When it receives an SS-AS invocation from FE21, FE221 determines the selected area definition corresponding to the area number invoked and passes it to FE222. It does not play any further role.

4.2.4 SS-AS operation controlling functional entity, FE222

When it receives an SS-AS invocation from FE221, FE222 determines the selected area definition corresponding to the area number invoked. It subsequently creates FE25s in the appropriate SwMIs. FE222 created for an individual call is cleared once that call has been established.

FE222 continues to exist during a group call. It creates FE25s in the new participating SwMIs if necessary for SS-AS operation (i.e. when only part of the new SwMI is within the selected area). When important users which were initially participating in the call change location during the call, FE222 should allow them to restore the call in inhibiting SS-AS operation if they have moved outside the selected area.

NOTE 1: Reminder: according to the definition of important user in subclause 3.1, in the present document, the calling user is defined as being an important user.

NOTE 2: If call restoration of an important user fails, especially if that user is the owner of the group call at that time, the basic group call procedure will apply.

4.2.5 SS-AS operating functional entity, FE25

When it receives an SS-AS invocation with the selected area definition, from FE222, FE25 ensures that the call is not established outside that area.

In the case of group call, FE25 can therefore be considered as a distributed functional entity, which bars the establishment of the call in all cells outside the selected area, except possibly for the calling user if he is outside that area. FE25 continues to operate during the call in ensuring that the group call is not extended beyond that area after it has been established.

NOTE 1: The above paragraph means that FE25 will bar the group members outside the selected area who attempt to join the group call later. It will also bar the operation of the supplementary service Late Entry (SS-LE) outside the selected area.

FE25 should support the inhibition of SS-AS operation for a group call (to be decided by FE222 for the call):

- at set-up time, for the calling user if he is outside the selected area; and
- during the call, when the calling user or other important users already participating in the call change location in roaming or migrating outside the selected, i.e. FE25 should then ensure that the call restoration request from that user is not barred by SS-AS operation (although it takes place outside the selected area).

NOTE 2: If it does not support the inhibition of SS-AS operation or if FE222 has not requested it, FE25 will ensure:

- that the calling user is not included in the call if he is outside the selected area. FE222 will then clear that call (see subclause 6.4); or
- that, when any of the so-called important users, including the calling user, changes location to a cell outside the selected area, the call restoration attempt of that user will fail. See note in subclause 4.2.3 if such user happens to be the owner of the group call at that time.

NOTE 3: Whether or not FE25 supports the inhibition of SS-AS operation, when any other initial participating user than the important users including the calling user, has roamed or migrated outside the selected area, the call restoration attempt of that user will fail.

In the case of individual call, FE25 is cleared once that call has been established, i.e. once the call has been established the connected user may restore it when he changes location in roaming or migrating outside the selected area.

4.2.6 Managed served user/group home SwMI FE, FE20

FE20 receives and processes the optional definition requests received from FE3.

NOTE: When the served user has migrated and is registered in a visited SwMI, the SS-AS definition stored by FE20 will be passed to FE21 in that SwMI by ANF-ISIMM (see ETS 300 392-3-5 [6]), possibly with the request to download it to the served user (if the authorized user has requested that such definition be assigned to the served user).

FE20 also receives and processes the optional interrogation requests received from FE3.

4.2.7 Authorized user functional entity, FE3

FE3 handles the sending the optional definition and/or interrogation requests passed by the authorized user application, and the reception of the optional definition and/or interrogation responses from FE20, in passing them to the authorized user application.

4.3 Relationship of functional model to basic call functional model

Although no formal models have been defined for basic individual call nor for basic group call, those models can be readily derived from the PISN model for basic call, in ISO/IEC 11574 [10].

Being call unrelated, the assignment, definition and interrogation procedures are independent of CC or CCA.

FE1 shall be collocated with the calling user CCA.

FE21 shall be collocated with the originating CC. Actually when the calling user invokes SS-AS for a group call in using an area number defined against that group (which is the basic method for invoking SS-AS for a group call), the SS-AS subscription function of FE21 shall be handled in the group controlling SwMI if at that time the originating SwMI has not been attached to the group.

NOTE 1: If the originating SwMI has been attached, it means that it has received the information whether or not SS-AS has been subscribed for the group (by the ANF-ISIMM group attachment service - see clause 8).

NOTE 2: Formally, FE21 should have been split into two functional entities to cater for the latter case. However it was judged that such splitting would make the model unnecessarily complex for all other scenarios.

In the case of a group call, FE222 shall be collocated with the transit CC in the group controlling SwMI, when that SwMI is different from originating SwMI, or the originating CC in the originating SwMI when the originating SwMI and the group controlling SwMI coincide, and FE221: either

- with the transit CC in the group controlling SwMI, when that SwMI is different from originating SwMI, or the originating CC in the originating SwMI when the originating SwMI and the group controlling SwMI coincide. This shall be the general case; or optionally
- with the originating CC in the originating SwMI when that SwMI is different from the group controlling SwMI.

In the case of an individual call, FE222 shall be collocated with the transit CC in the called user home SwMI when that SwMI is different from the originating SwMI or the originating CC in the originating SwMI when the originating SwMI and the called user home SwMI coincide, and FE221: either

- with the originating CC in the originating SwMI. This shall be the general case; or optionally
- with the transit CC in the called user home SwMI when that SwMI is different from the originating SwMI.

NOTE 3: When FE221 is collocated with the originating SwMI, the relationship rb becomes internal to that SwMI.

NOTE 4: When FE221 is collocated with the called user home SwMI, if the -individual- call is then established by rerouteing, the protocol for sending the SS-AS information flow over relationship rd actually relays it through the originating SwMI. However such relaying is a stage 3 description issue and not to be taken into account in the stage 2 description.

FE25 shall be collocated:

- in the case of an individual call, with the terminating CC or with the transit CC in the called user home SwMI when that SwMI is different from the terminating SwMI;
- in the case of a group call for which SS-AS is operated with no SS-AS inhibition for the calling user and other important users:
 - with the originating CC in the originating SwMI if it lies partly outside the selected area;
 - with each terminating CCs in the SwMIs where group members are attached and which lie partly outside the selected area (e.g. in the group controlling SwMI for the participants registered in that SwMI, or in the participating SwMIs for the other participants);
 - with the transit CC in the group controlling SwMI:
 - for the originating SwMI if those two SwMIs are different and if the originating SwMI is totally outside the selected area; and
 - for the participating SwMIs totally outside the selected area.
- in the case of a group call for which SS-AS is operated with SS-AS inhibition for the calling user:
 - with the same CCs as if SS-AS was operated with no SS-AS inhibition (i.e. originating CC if the originating SwMI lies partly outside the selected area, terminating CCs in the SwMIs where group members are attached and which lie partly outside the selected area, and transit CC in the group controlling SwMI when the latter has determined that the originating SwMI or some participating SwMIs are totally outside the selected area);
 - with the new terminating CCs in the new participating SwMIs which lie partly or totally outside the selected area (for call restoration).

Figure **Error! Reference source not found.** shows an example of the relationship between the models for SS-AS and:

- for the basic group call in the basic case where the definition of the selected area number is given in the group home SwMI; and
- for the basic individual call in the optional case where the definition of the selected area number is given in the called user home SwMI.

This example is used as the basis of most of information flow sequences in subclause 5.4.

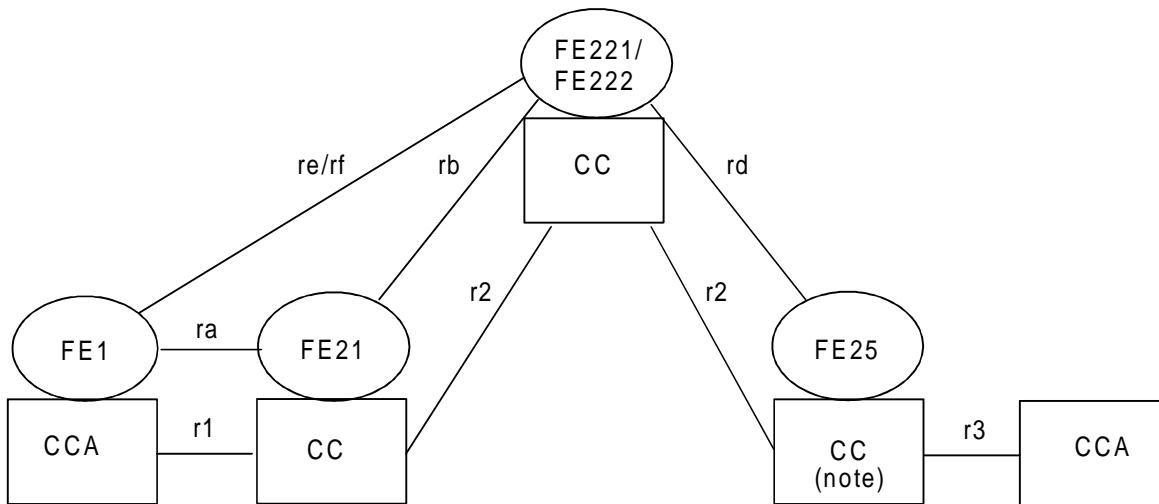

NOTE: The CC to which the called user CCA, on the right, is associated coincides with the transit CC shown in the middle of the figure (with FE221 and FE222 collocated) when the called user is registered in his home SwMI (whether for an individual call or for a group call).

Figure 3: Relationship between models for SS-AS and basic group call or basic individual call in the case where FE221 is collocated with the called user/group home SwMI

Figure 4 shows another example of the relationship between the models for SS-AS and:

- for the basic individual call in the basic case where the definition of the selected area number is given in the originating SwMI; and
- for the basic group call in the optional case where the definition of the selected area number is given in the originating SwMI.

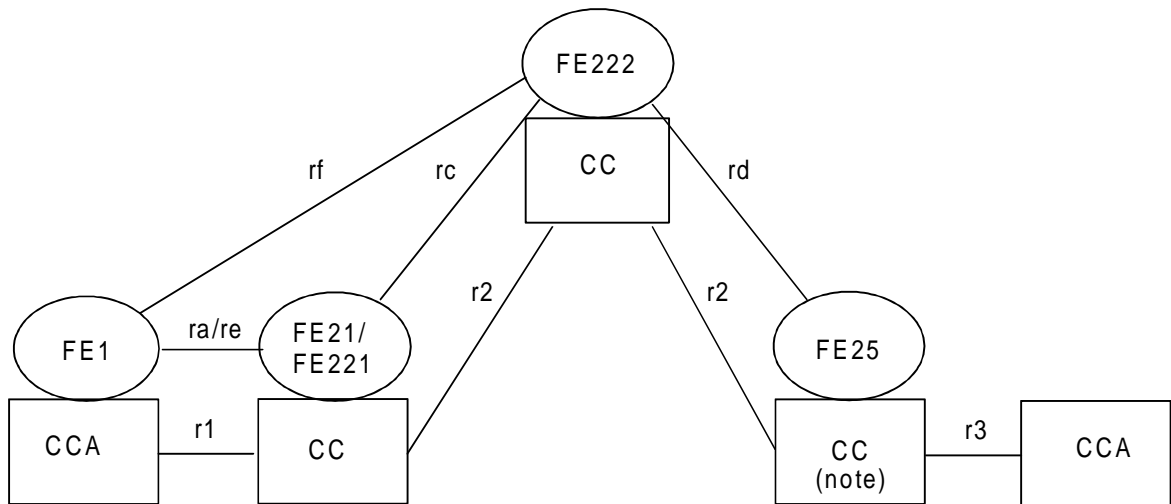

NOTE: The CC the called user CCA, on the right, is associated coincides with the transit CC shown in the middle of the figure (with FE222 collocated) when the called user is registered in his home SwMI (whether for an individual call or for a group call).

Figure 4: Relationship between models for SS-AS and basic individual call or basic group call in the case where FE221 is collocated with the originating SwMI

5 Information flows

5.1 Definition of information flows

In the tables listing the information elements in information flows, the column headed "Type" indicates which of these elements are Mandatory (M), which are Optional (O) and which are Conditional (C).

5.1.1 ASSIGN

ASSIGN an unconfirmed information flow across relationship ra from FE21 to FE1 which assigns to the SS-AS served user MS/LS the selectable area definition corresponding to an area number.

NOTE 1: Subclause 5.1.3 provides that every member of a group is a served user to whom the selectable area definitions for a group may be assigned. No SS-AS assignment for a group will be made to any other user, not member of that group, although nothing will prevent such user from being SS-AS served user, when setting up a call for that group (i.e. being the calling user for the group call).

Table 1 lists the elements within the ASSIGN information flow.

Table 1: Contents of ASSIGN

Element	Type
Area number	M (note 1)
Selectable area definition	M (note 2)
Acknowledgement requested	O
NOTE 1: May be repeated.	
NOTE 2: Shall be repeated as many times as the element area number.	

The element area number shall be the indicator used to invoke SS-AS.

The element selectable area definition shall give the detailed definition corresponding to the preceding area number. Such definition may be a "site" definition or a geographical definition.

When an acknowledgement is requested from the served user(s), it shall be sent by the ASSIGN ACK information flow (see subclause 5.1.2), which may then be considered as a response/confirmation information flow corresponding to the ASSIGN request/indication information flow.

NOTE 2: When the ASSIGN request/indication information flow corresponds to a definition made for an individual user (see subclause 5.1.3), it will be sent to that user. When the ASSIGN request/indication information flow corresponds to a definition made for a group (see subclause 5.1.3), it will either be broadcast to all members of that group or sent individually to each.

5.1.2 ASSIGN ACK

ASSIGN ACK is actually the response/confirmation information flow corresponding to the ASSIGN request/indication information flow. It is thus across relationship ra from FE1 to FE21. That flow is used to inform FE21 about the completion of the corresponding assignment request.

NOTE 1: The definition of how a given ASSIGN ACK information flow relates to the corresponding ASSIGN information flow is outside the scope of the stage 2 description.

Table 2 defines the content of the ASSIGN ACK information flow.

Table 2: Content of ASSIGN ACK

Element	Type
Assignment result	M

The element assignment result shall indicate whether the assignment requested in the corresponding ASSIGN request/indication information flow has been successful or not.

NOTE 2: In the case of assignment of area number definition for a group, when the corresponding ASSIGN information flow broadcast to the group members included an assignment acknowledgement, the ASSIGN ACK information flow will be sent by each member of the group - except those which did not receive the ASSIGN information flow.

5.1.3 DEFINE

DEFINE is an unconfirmed information flow across relationship rg from FE3 to FE20, which defines the selectable area corresponding to a SS-AS area number for individual subscriber(s) or group(s).

NOTE 1: The response/confirmation information flow corresponding to the DEFINE request/indication information flow is DEFINE ACK (see subclause 5.1.4).

Table 3 lists the elements within the DEFINE information flow.

Table 3: Contents of DEFINE

Element	Type
Defined individual subscriber/group identity	M (note 1)
Area number	M (note 2)
Selectable area definition	M (note 3)
Assignment requested	M
Acknowledgement requested	C (note 4)
NOTE 1: May be repeated. NOTE 2: May be repeated. NOTE 3: Shall be repeated as many times as the element area number. NOTE 4: Such acknowledgement may be requested only together with the assignment of the selectable area definition(s) (by the element "assignment requested").	

The element defined individual subscriber/group identity shall contain the identity of the group or of the individual subscriber being defined. When the DEFINE request/indication information flow is used with the element defined individual subscriber/group identity having the value of a group identity, the area number shall apply to calls to this group. When it is used with the element defined individual subscriber/group identity having the value of an individual identity, the area number shall apply to individual calls made by the individual user. It may also apply to group calls made by that user.

See subclause 5.1.1 for the meaning of the elements area number and selectable area definition.

The element "assignment requested" shall indicate if the definition(s) of the area number(s) is(are) to be assigned to the served user(s). If so, the value of the element "assignment requested" shall indicate whether or not such assignment is to be acknowledged.

If the DEFINE request/indication information flow defines one or more area numbers for a group and requests such definition to be assigned to the served user(s) (i.e. the value of its element individual subscriber/group identity corresponds to a group identity, and that of its element assignment requested, to the request of such assignment), every member of the group shall be a served user.

NOTE 2: Thus the value of the element "assignment requested" indicates whether or not one or more ASSIGN request/indication information flow will be generated as a result of the DEFINE request/indication information flow.

5.1.4 DEFINE ACK

DEFINE ACK is actually the response/confirmation information flow corresponding to the DEFINE request/indication information flow. It is thus across relationship rg from FE20 to FE3. That flow is used to inform FE3 about the completion of the corresponding definition request.

NOTE: The definition of how a given DEFINE ACK information flow relates to the corresponding DEFINE information flow is outside the scope of the stage 2 description.

Table 4 lists the elements within the DEFINE ACK information flow.

Table 4: Contents of DEFINE ACK

Element	Type
Definition result	M (note 1)
Defined individual subscriber/group identity	M (note 2)
Area number	C (notes 3 and 4)
NOTE 1:	There shall be only one definition result even if there are more than one defined individual/group identity or more than one area number.
NOTE 2:	May be repeated.
NOTE 3:	Present if the definition result is positive.
NOTE 4:	May be repeated.

The element definition result shall indicate if the DEFINE request/indication information flow has been successful or not for the individual subscriber or group identified by the value of element defined individual subscriber/group identity. Of course such value shall have to have been used in a previous DEFINE request/indication information flow. If the definition has been successful, the element area number shall indicate which area number(s) has/have been successfully defined. See subclause 5.1.1 for the meaning of that element.

5.1.5 INTERROGATE

INTERROGATE is an unconfirmed information flow across relationship rg from FE3 to FE20 which is used to interrogate the home SwMI of an individual subscriber or of a group about the current definitions of the SS-AS area numbers for that subscriber or for that group.

NOTE: The response/confirmation information flow corresponding to the INTERROGATE request/indication information flow is INTERROGATE ACK (see subclause 5.1.6).

Table 5 defines the content of the INTERROGATE information flow.

Table 5: Content of INTERROGATE

Element	Type
Interrogated individual subscriber/group identity	M

The element defined interrogated individual subscriber/group identity shall contain the identity of the group or of the individual subscriber for whom the interrogation is placed.

5.1.6 INTERROGATE ACK

INTERROGATE ACK is actually the response/confirmation information flow corresponding to the INTERROGATE request/indication information flow. It is thus across relationship rg from FE20 to FE3. It is used to respond to the corresponding interrogation request.

NOTE: The definition of how a given INTERROGATE ACK information flow relates to the corresponding INTERROGATE information flow is outside the scope of the stage 2 description.

Table 6 lists the elements within the INTERROGATE ACK information flow.

Table 6: INTERROGATE ACK contents

Element	Type
Interrogation result	M (note 1)
Interrogated individual subscriber/group identity	M
Area number	C (note 2 and 3)
Selectable area definition	C (note 2 and 4)
Assignment requested	C (note 2)
Acknowledgement requested	C (note 5)
NOTE 1: There shall be only one interrogation result even if there are more than one interrogated individual subscriber/group identity or more than one area number.	
NOTE 2: Conditional on the interrogation result being positive.	
NOTE 3: Shall be repeated for each value corresponding to a different area number defined.	
NOTE 4: Shall be repeated as many times as the element area number.	
NOTE 5: Such acknowledgement may have been requested only together with the assignment of the selectable area definition(s) (by the element "assignment requested").	

The element interrogated individual subscriber/group identity shall indicate the identity of the individual subscriber or group for which the response to a previous interrogation is being given in the INTERROGATE ACK information flow.

The element interrogation result shall indicate if the INTERROGATE information flow request/indication has been successful or not. If it has been successful, the elements area number and selectable area definition (see subclause 5.1.1 for their meanings) shall indicate which area number(s) has/have been successfully defined and the corresponding definition, respectively.

The element assignment requested shall indicate that the area definition has been requested to be sent to the served users for their information. If yes, the element acknowledgement requested shall indicate if the served user(s) has/have been requested to acknowledge the reception of the information.

5.1.7 INVOKE

INVOKE is an unconfirmed information flow across relationships ra from FE1 to FE21 and rb from FE21 to FE221 to invoke SS-AS.

Table 7 lists the elements within the INVOKE information flow.

Table 7: Contents of INVOKE

Element	Type
Area number	M
SwMI where the selected area number is defined	O (note 1)
Support of SS-AS inhibition for calling user	O (note 2)
<p>NOTE 1: When this element is not present, the default SwMI shall be:</p> <ul style="list-style-type: none"> - in the case of an individual call, the originating SwMI; - in the case of a group call, the group home SwMI. <p>Shall be present to indicate the SwMI where the area number is defined when that SwMI is different from the default one.</p> <p>NOTE 2: Shall be present only when INVOKE is sent over relationship rb for a group call (i.e. shall not present when INVOKE is sent over relationship ra for a group call or for an individual call or over relationship rb for an individual call).</p>	

See subclause 5.1.1 for the meaning of the element area number. The area corresponding to that number shall be that defined:

- for the group identity if the call is a group call and if the element destination SwMI is not present;
- for the calling party if the call is an individual call and if the element destination SwMI is not present;
- in the SwMI indicated by the element SwMI where the selected area number is defined when the latter is present.

If present, the element SwMI where the area number is defined shall indicate:

- in the case of an individual call, the called user home SwMI, unless that SwMI coincides with the originating SwMI;
- in the case of a group call, the originating SwMI, unless that SwMI coincides with the group home SwMI.

The element support of SS-AS inhibition for calling user shall indicate whether or not FE25 if collocated with the originating CC supports SS-AS inhibition for the calling user if he is outside the selected area.

5.1.8 INVOKE CONFIRM

INVOKE CONFIRM is an unconfirmed information flow across relationship rd from FE25 to FE222 to inform the group controlling SwMI (in the case of a group call) that:

- the calling user is within the selected area when the originating SwMI lies partly within that area. It is then a positive response to the INVOKE EXT request/indication information flow sent to FE25 in that SwMI;
- some important users known to be registered a given participating SwMI are within the selected area when the group call is acknowledged and when that SwMI lies partly within that area; It is then a positive response to the INVOKE EXT request/indication information flow sent to FE25 in that SwMI.

Table 8 defines the content of the INVOKE CONFIRM information flow.

Table 8: Content of INVOKE CONFIRM

Element	Type
List of important users within the selected area	O
NOTE: Shall be present when INVOKE CONFIRM is sent by a participating SwMI when the group call being established is an acknowledged group call.	

If present in the INVOKE CONFIRM information flow, the element list of important users within the selected area shall give the identities of all the important users within the selected area as controlled by the FE25 entity which sends that information flow.

5.1.9 INVOKE EXT

INVOKE EXT is an unconfirmed information flow across relationship rc from FE221 to FE221 and relationship rd from FE222 to FE25 to extend the SS-AS invocation in giving the definition of the element area number in the corresponding INVOKE request/indication information flow.

Table 9 lists the elements within the INVOKE EXT information flow.

Table 9: Contents of INVOKE EXT

Element	Type
Selected area definition	M
SS-AS inhibition requested for calling user and for other important users roaming or migrating	O (note)
NOTE: Shall only be present when INVOKE EXT is sent for a group call across relationship rd.	

The element selected area definition shall give the detailed definition corresponding to the invoked area number (in the corresponding INVOKE information flow). Such definition may be a "site" definition or a geographical definition.

The element SS-AS inhibition requested for calling user and for other important users roaming or migrating shall indicate whether FE222 is asking FE25 to inhibit or not inhibit SS-AS operation:

- for the calling user (of a group call) at set-up time if he is located outside the selected area; and
- during the call still for the calling user and for other important users already participating in the call when they roam or migrate outside the selected area.

5.1.10 NOT DEFINED

NOT DEFINED is an unconfirmed information flow across relationship re from FE221 to FE1 to inform the calling user who has invoked SS-AS using an area number that that invocation has failed because that area number is not defined (in FE221).

NOTE: The above statement implies that there is a FE221 functional entity. Otherwise, this means that the SwMI where FE221 should be located does not support SS-AS and by definition there is no information flow NOT DEFINED. In such a case, the calling user who has invoked SS-AS may nevertheless be informed about the invocation failure by some generic failure reports of the protocol used for SS-AS, e.g. over the ISI (see subclause 5.4.1.2.1 of ETS 300 392-12-8 [9]).

There are no elements in the NOT DEFINED information flow.

5.1.11 NOT SUBSCRIBED

NOT SUBSCRIBED is an unconfirmed information flow across relationship ra from FE21 to FE1 to inform the calling user who has invoked SS-AS that that invocation has failed because the supplementary service has not been subscribed for that user.

NOTE: The above statement implies that there is a FE21 functional entity. Otherwise, this means that the originating SwMI does not support SS-AS and by definition there is no information flow NOT SUBSCRIBED. In such a case, the calling user who has invoked SS-AS may nevertheless be informed about the invocation failure by some generic failure reports of the air interface protocol used for SS-AS (see subclause 5.4.1.2.1 of ETS 300 392-12-8 [9]).

There are no elements in the NOT SUBSCRIBED information flow.

5.1.12 NOT SUPPORTED

NOT SUPPORTED is an unconfirmed information flow across relationship rf from FE222 to FE1, relationship re from FE221 to FE1 or across relationship ra from FE21 to FE1 to inform the calling user who has invoked SS-AS that that invocation has failed because some other SwMI than the served user SwMI also on the path of the call does not support SS-AS. It may also be used across relationship rd from FE25 to FE222 to inform it that it does not support the type of definition of the selected area (which FE25 has received in the INVOKE EXT request/indication information flow).

Table 10 defines the content of the NOT SUPPORTED information flow.

Table 10: Content of NOT SUPPORTED

Element	Type
Cause for non-support of the invoked SS-AS	M

The element cause for non-support of the invoked SS-AS shall indicate:

- if FE21 exists, that FE221 is missing (i.e. SS-AS supported by originating SwMI but not by group home SwMI in a group call or SS-AS optional invocation in an individual call using the area number definition in the called user home SwMI not supported by the latter);
- if FE21 and FE221 exist, that FE222 is missing (i.e. SS-AS supported by originating SwMI but not by group/called user home SwMI); or
- if FE21, FE221 and FE222 exist, that FE25 is missing partially or totally (i.e. SS-AS not supported by some participating SwMI(s) in the case of a group call or by the terminating SwMI in the case of an individual call), else type of definition of the selected area not supported by such participating SwMI(s) or by terminating SwMI).

5.2 Relationship of information flows to basic call information flows

Table 11 shows the relationship of the SS-AS information flows to those of basic call over both the air interface and the intersystem interface (ISI).

NOTE: The basic individual call information flows are defined:

- for the air interface, if not explicitly in ETS 300 392-2 [3], at least implicitly in clause 11 and 14 of that ETS; and
- for the ISI, in ETS 300 392-3-2 [4].

Table 11: Relationship of SS-AS information flows to basic call

Information flow	Independent of basic call?	With basic call?	Basic call flows:
DEFINE	yes (note 1)	no	
DEFINE ACK	yes (note 1)	no	
INTERROGATE	yes (note 1)	no	
INTERROGATE ACK	yes (note 1)	no	
INVOKE	no	yes	Air interface SETUP request/indication (note 2) ANF-ISIGC-ORIGINATING SETUP request/indication (note 2) ANF-ISIIC-SETUP request/indication (note 2)
INVOKE CONFIRM	yes (note 3)	yes (note 3)	ANF-ISIGC-SETUP response/confirmation (note 4)
INVOKE EXT	yes (note 6)	yes (note 5)	ANF-ISIGC-SETUP request/indication (note 5) ANF-ISIGC-ORIGINATING SETUP request/indication (note 5) ANF-ISIIC-SETUP request/indication (note 5) ANF-ISIGC-CALL RESTORE PREPARE (note 5)
NOT DEFINED	yes (note 7)	yes (note7)	SETUP response/confirmation (note8)
NOT SUBSCRIBED	yes (note 9)	yes (note9)	Air interface PROCEED (note10) Air interface SETUP response/confirmation (note 11)
NOT SUPPORTED	yes (note 7)	yes (note7)	SETUP response/confirmation (note8)
NOTE 1:	This information flow is not only independent of basic call, but call unrelated.		
NOTE 2:	INVOKE shall always be sent: - across relationship ra together with the air interface SETUP request/indication information flow; and - unless relationship rb is internal to the originating SwMI, across that relationship together with the ANF-ISIGC-ORIGINATING SETUP request/indication information flow in the case of a group call (case where FE221 is located in the group home SwMI) or the ANF-ISIIC-SETUP request/indication information flow in the case of an individual call (case where FE221 is located in the called user home SwMI).		
NOTE 3:	This information flow is always call related but not necessarily sent together with the basic call ANF-ISIGC-SETUP response/confirmation information flow.		
NOTE 4:	The PDU corresponding to that ANF-ISIGC-SETUP response/confirmation information flow is ANF-ISIGC-SETUP ACKNOWLEDGE.		
NOTE 5:	In the case of a group call, INVOKE EXT shall be sent: - when relationship rc is not internal to the group home SwMI, across that relationship together with the ANF-ISIGC-ORIGINATING SETUP request/indication information flow; - when relationship rd is not internal to the group controlling SwMI, across that relationship: - either together with the ANF-ISIGC-SETUP request/indication information flow or before it (see note 6); and if the group controlling SwMI supports the (group) call restoration, together with the ANF-ISIGC-CALL RESTORE PREPARE request/indication information flow. In the case of an individual call, when relationships rc or rd are not internal to the called user home SwMI, INVOKE EXT shall be sent across those relationships together with the ANF-ISIIC-SETUP request/indication information flow.		
NOTE 6:	INVOKE EXT may be sent before the ANF-ISIGC-SETUP request/indication information flow from FE222 to FE25 in the originating SwMI (the PDU corresponding to that information flow is ANF-ISIGC-SETUP INITIATE PDU) for allowing the group controlling SwMI to find out whether or not the calling user is outside the selected area before progressing further in the establishment of the group call - in sending the ANF-ISIGC-SETUP request/indication information flows to the originating SwMI and the participating SwMIs, for preparing the establishment of that call to the called group members in those SwMIs.		

NOTE 7:	This information flow is always call related but not necessarily sent together with the basic call SETUP response/confirmation information flow.
NOTE 8:	The PDUs corresponding to that SETUP response/confirmation information flow are either D-ALERTING and ISI-ALERTING in the case of an individual call using on/off hook signalling or D-CONNECT and ISI-CONNECT in the case of a group call or of an individual call using direct set-up signalling.
NOTE 9:	NOT SUBSCRIBED is always call related but not necessarily sent together with the air interface basic call PROCEED request/indication or SETUP response/confirmation information flows.
NOTE 10:	The PDU corresponding to the air interface PROCEED request/indication information flow is D-CALL PROCEEDING.
NOTE 11:	The air interface PDU corresponding to the air interface SETUP response/confirmation information flow is either D-ALERTING in the case of an individual call using on/off hook signalling or D-CONNECT in the case of a group call or of an individual call using direct set-up signalling.

5.3 Service primitives

This clause lists SS-AS service primitives used to invoke or being a result of information flow sequences. The SS-AS service primitives are defined in subclause 5.4 of ETS 300 392-12-8 [9].

The SS-AS service primitives for the served user at the MS/LS TNSS-SAP shall be:

- ASSIGN indication;
- INVOKE request;
- INVOCATION FAILURE indication.

NOTE: There is no ASSIGN ACK request primitive because when assignment acknowledgement is requested (in the ASSIGN request/indication information flow), it is sent by FE1.

The SS-AS service primitives for the authorized user at the MS/LS TNSS-SAP shall be:

- DEFINE request;
- DEFINE ACK indication;
- INTERROGATE request;
- INTERROGATE ACK indication.

5.4 Examples of information flow sequences

ETS 300 392-12-8 [9], on SS-AS stage 3 description, provides signalling procedures in support of the information flow sequences specified in the following subclauses. In addition, it provides signalling procedures to cover other sequences arising from error situations, interactions with basic call, interactions with other supplementary services, different topologies etc.

In the figures, SS-AS information flows are represented by solid arrows and basic call information flows are represented by broken arrows. An ellipse embracing two information flows indicates that the two information flows occur together. Within a column representing an SS-AS functional entity, the numbers refer to functional entity actions listed in clause 6.

5.4.1 Definition

5.4.1.1 Definition with no assignment

Figure 5 shows the information flow sequence for the normal operation of SS-AS definition in the case where no assignment to served user(s) has been requested.

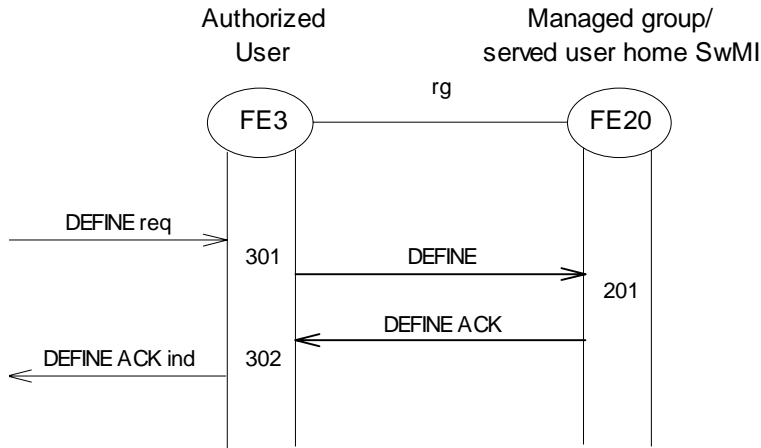

Figure 5: Definition of SS-AS with no assignment to served user(s)

NOTE: The SS-AS definition is then passed by FE20 to F21 by the ANF-ISIMM SS-PROFILE information flow (see clause 8).

5.4.1.2 Definition with assignment

Figure 6 shows the information flow sequence for the normal operation of SS-AS definition in the case where its assignment to the served user(s) has been requested and when that user (those users) has migrated (have migrated in the same SwMI).

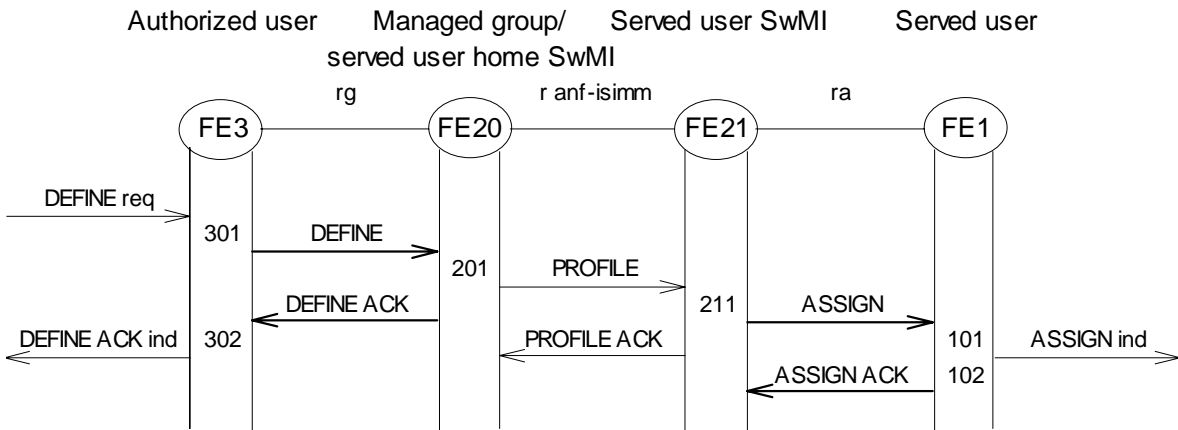

Figure 6: Definition of SS-AS with assignment to the served user(s)

5.4.2 Interrogation

Figure 7 shows the information flow sequence for the normal operation of SS-AS interrogation.

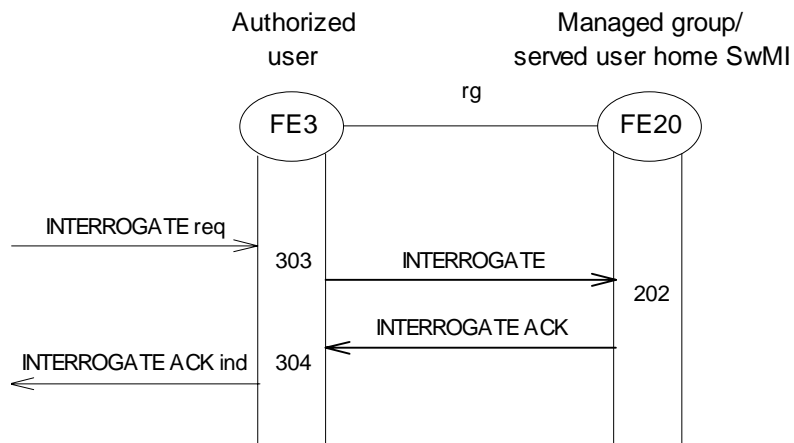

Figure 7: Interrogation of SS-AS

5.4.3 Invocation and operation

5.4.3.1 Invocation for individual call with successful operation

5.4.3.1.1 Successful call establishment

Figures 8, 9 and 10 show the information flow sequences for the successful SS-AS invocation and operation for an individual call when it results in the call being established (i.e. the called user is within the selected area) in the three following cases respectively:

- when the definition of the selected area number is given in the originating SwMI (this is the basic case for an individual call) and the terminating SwMI lies partly within the selected area;
- when the definition of the selected area number is given in the originating SwMI (again this is the basic case for an individual call) and the terminating SwMI lies wholly within the selected area;
- when the definition of the selected area number is given in the called user home SwMI (this is an optional case for an individual call) and the terminating SwMI lies partly within the selected area.

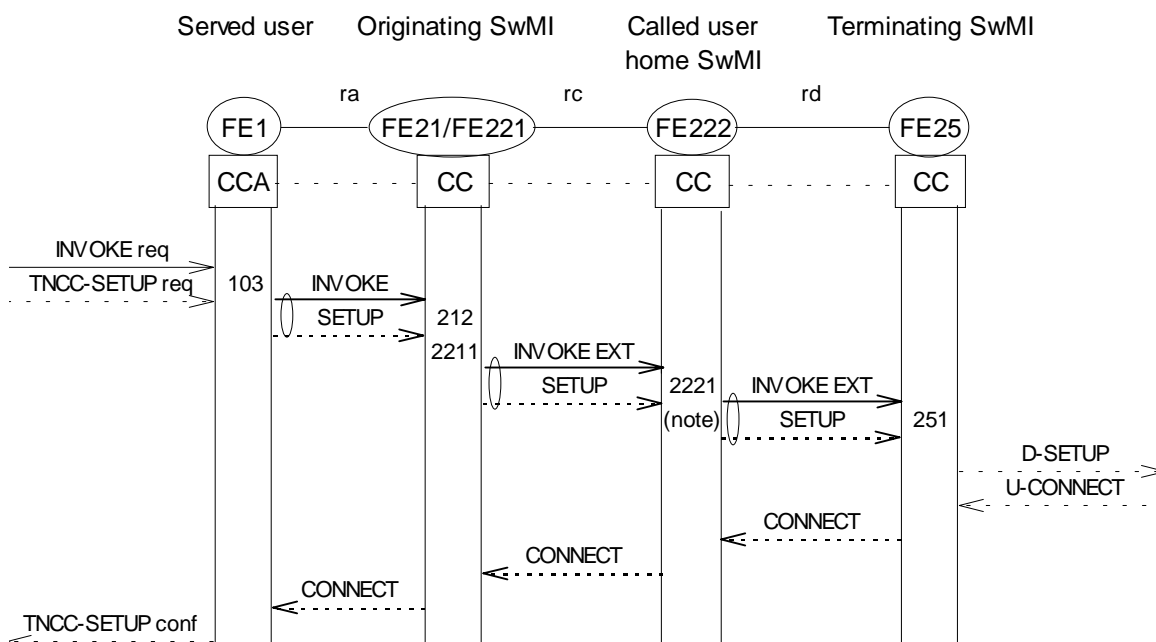

NOTE: Generally the definition of the selected area number as known by the originating SwMI will be modified by the called user home SwMI to be adapted to the terminating SwMI.

The case shown on the figure corresponds to the establishment of the call by forward switching. The case of establishment of the call by rerouting would be more complex, because the (basic call) ANF-ISIIC SETUP request/indication information flow would go back from the called user home SwMI to the originating SwMI, and then from the originating SwMI to the terminating SwMI. However it would not change the fact that the INVOKE EXT information flow between FE222 and FE25 would still remain between those two functional entities.

Figure 8: Basic invocation and operation of SS-AS over ISI - successful establishment of individual call in the case where the selected area definition is given in the originating SwMI and the terminating SwMI lies partly within the selected area

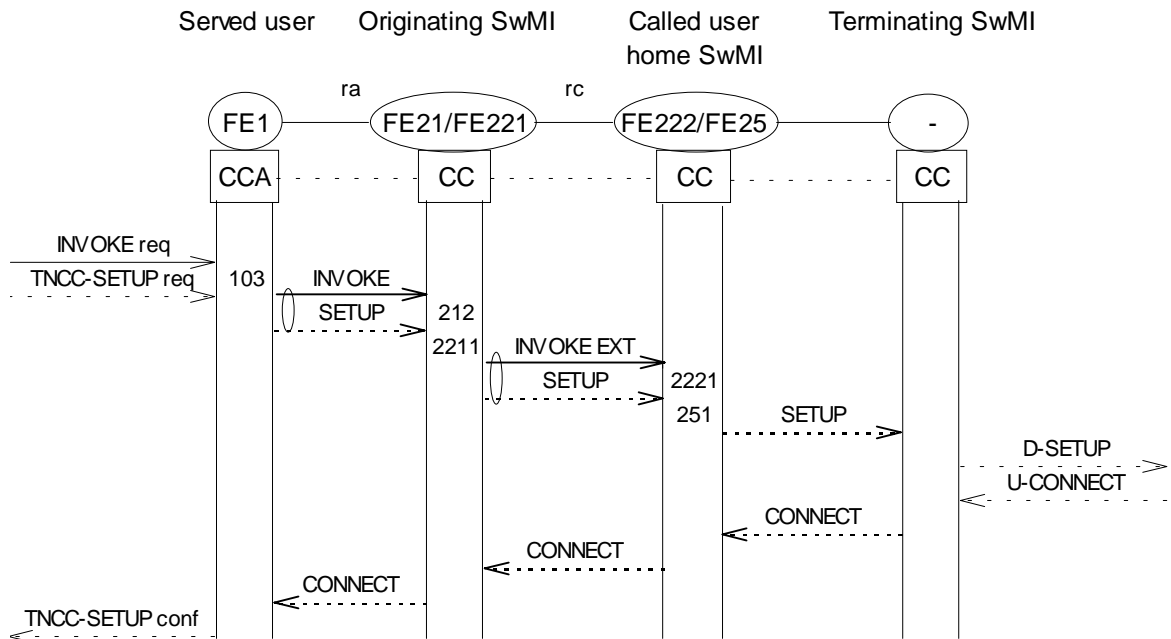
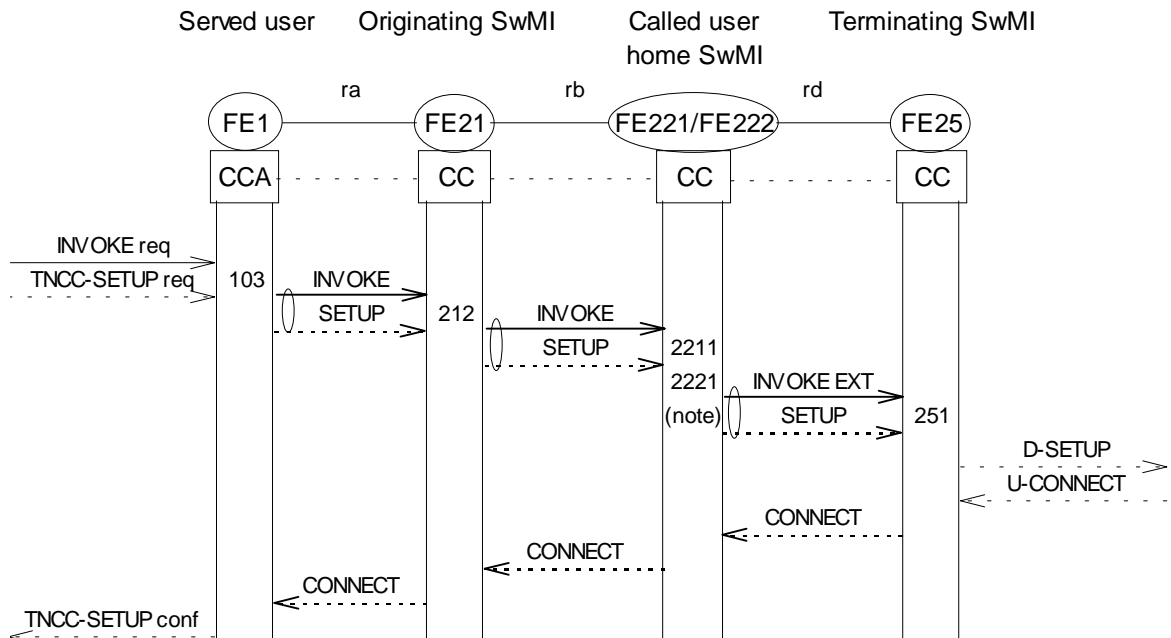

Figure 9: Basic invocation and operation of SS-AS over ISI - successful establishment of individual call when the selected area definition is given in the originating SwMI and the terminating SwMI lies partly within the selected area

NOTE: In figures 8 and 9, since both FE21 and FE221 are collocated, in the originating SwMI, relationship rb will be internal to that SwMI.



NOTE: See note in figure 8.

Figure 10: Extended invocation and operation of SS-AS over ISI - successful establishment of individual call when the selected area definition is given in the called user home SwMI

5.4.3.1.2 Call attempt cleared by SS-AS

Figures 11 and 12 show the information flow sequences for the successful SS-AS invocation and operation for an individual call when it results in the call attempt failure because the called user is outside the selected area, in the two following cases respectively:

- when the definition of the selected area number is given in the originating SwMI and is passed by the called user home SwMI up to the terminating SwMI which then determines that the called user is outside the selected area;
- when the definition of the selected area number is given in the originating SwMI and is passed to the called user home SwMI which then determines that the called user is outside the selected area because the terminating SwMI is completely outside the selected area.

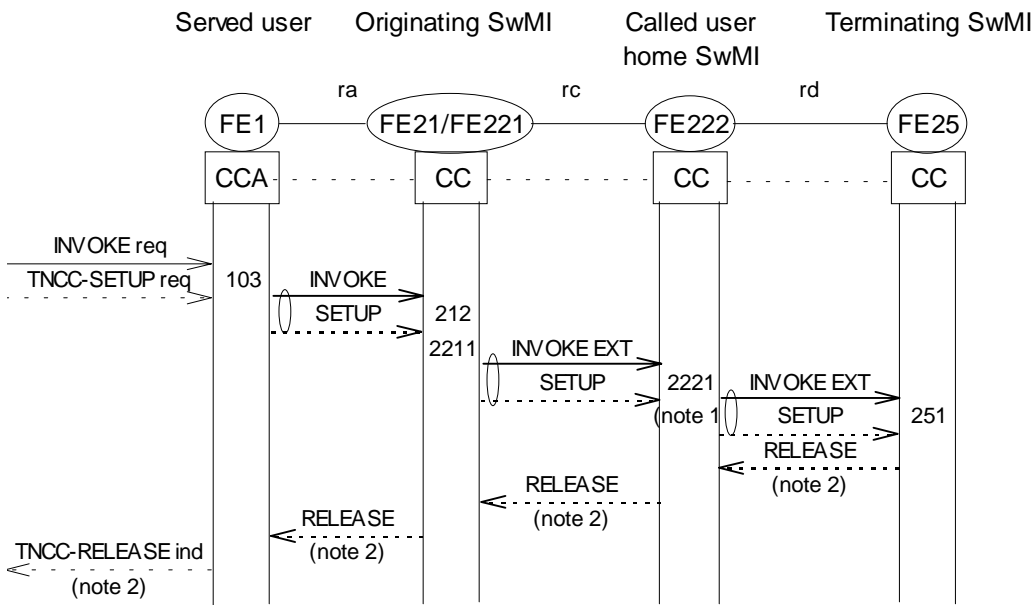

NOTE 1: See note in figure 8.

NOTE 2: In the case where the call is cleared as a result of action 251, the disconnect cause for the basic call RELEASE information flow shall be "SS-AS operation".

Figure 11: Basic invocation and operation of SS-AS over ISI resulting in individual call attempt cleared because of successful operation when the called user has migrated in a terminating SwMI partly within the selected area

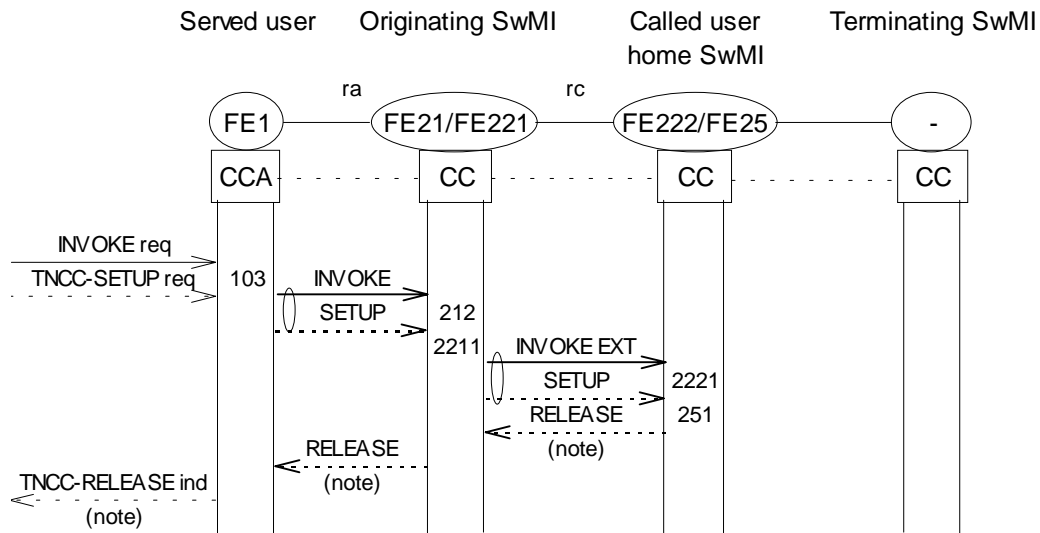

NOTE: See note 2 in figure 11.

Figure 12: Basic invocation and operation of SS-AS over ISI resulting in individual call attempt cleared because of successful operation when the called user has migrated in a terminating SwMI completely outside the selected area

5.4.3.2 Invocation for group call with successful operation

5.4.3.2.1 Successful call establishment

Figures 13, 14 and 15 show the information flow sequences for the successful SS-AS invocation and operation for a group call when the definition of the selected area number is given in the group home SwMI (this is the basic case for a group call) when there are group members in a participating SwMI which lies partly within the selected area and when SS-AS operation results in the call being established in the three following cases respectively:

- when the originating SwMI lies wholly within the selected area and there are group members to be called (i.e. other than the calling user if he is a group member) in that SwMI;
- when the originating SwMI lies partly within the selected area and the group controlling SwMI has decided that SS-AS operation shall not be inhibited for the calling user and checks that the calling user is within the selected area and there are group members to be called (i.e. other than the calling user if he is a group member) in that SwMI;
- when the originating SwMI is completely outside the selected area and the group controlling SwMI has decided that SS-AS operation shall be inhibited for the calling user.

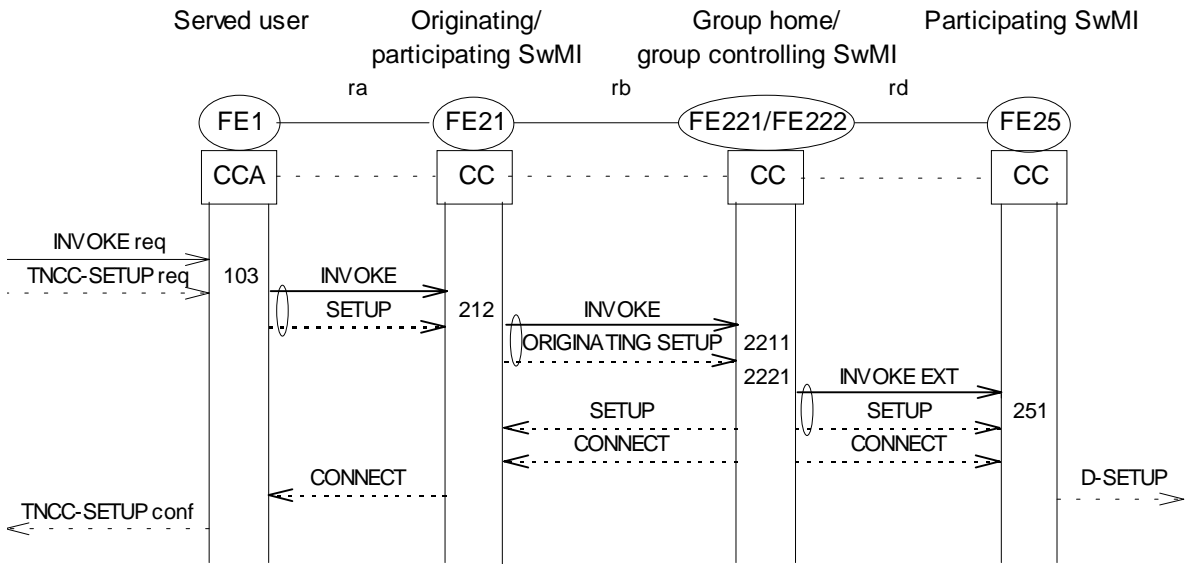

Figure 13: Basic invocation and operation of SS-AS over ISI - successful establishment of group call when the selected area definition is given in the group home SwMI and the originating SwMI lies wholly within the selected area

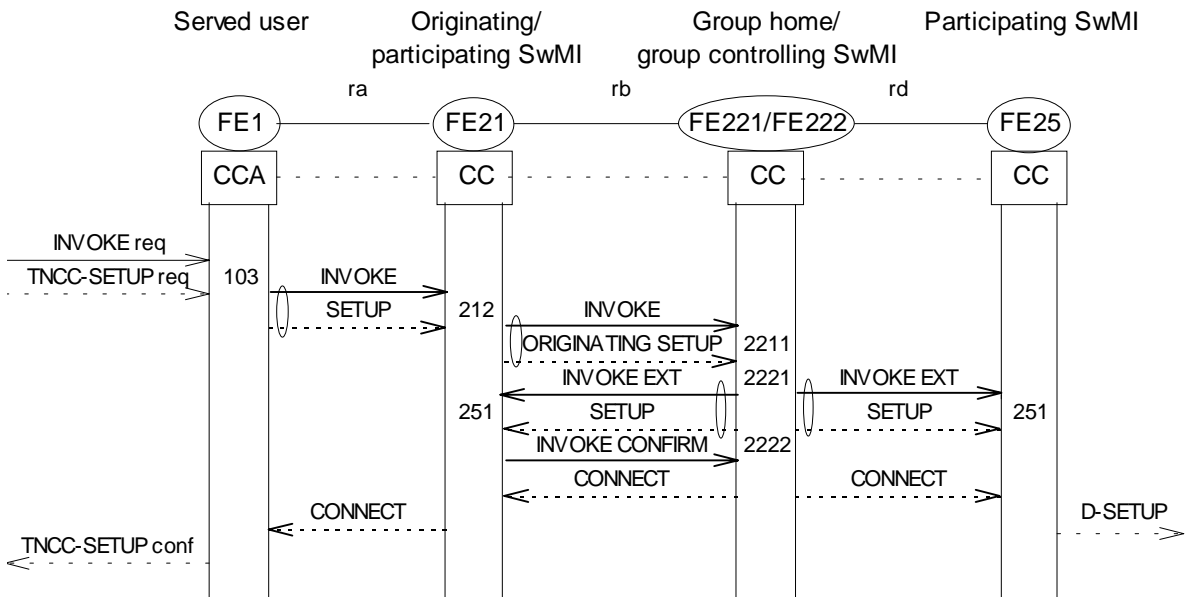
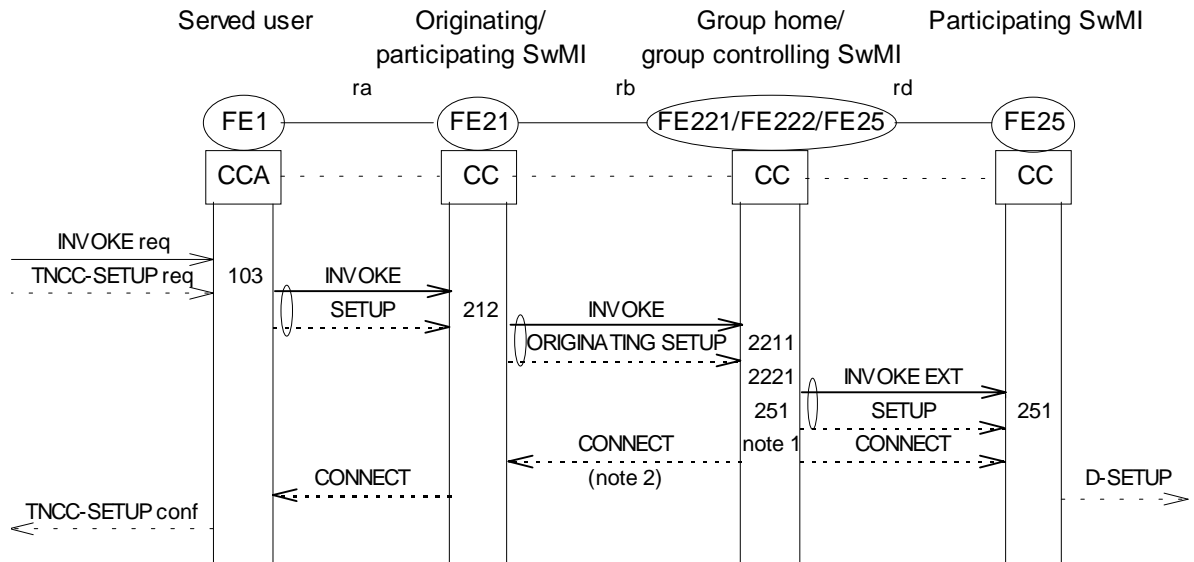

Figure 14: Basic invocation and operation of SS-AS over ISI - successful establishment of group call when the selected area definition is given in the group home SwMI and no SS-AS inhibition for calling user with the originating SwMI lying partly within the selected area



NOTE 1: The action 251 for the FE25 entity located in the group controlling SwMI is for barring the establishment of the group call in the originating SwMI except for the calling user.

NOTE 2: Logically the group controlling SwMI does not need to send the ANF-ISIGC-SETUP request/indication information flow to the originating SwMI since the calling user will be the only user participating in the group call in that SwMI once that call will have been established. The ISI-CONNECT information flow shown on the figure can be considered as an ANF-ISIIC-CONNECT information flow, i.e. its only purpose being to connect the calling user to the group call in the originating SwMI, and no other users.

Figure 15: Basic invocation and operation of SS-AS over ISI - successful establishment of group call when the selected area definition is given in the group home SwMI and SS-AS inhibition for calling user with the originating SwMI completely outside the selected area

Figure 16 shows the information flow sequence for the successful SS-AS invocation and operation for an acknowledged group call when the definition of the selected area number is given in the originating SwMI (this is an optional case for a group call).

NOTE 1: Figure 16 shows the case where a participating SwMI lies partly within the selected area and where the originating SwMI lies wholly within that area. The sequences for the other scenarios for FE25s allocation (e.g. an FE25 functional entity is collocated with FE21 in the originating SwMI) could be derived by combining action 221 and the related sending of INVOKE EXT in figure 16 by FE21 with figures 14 and 15.

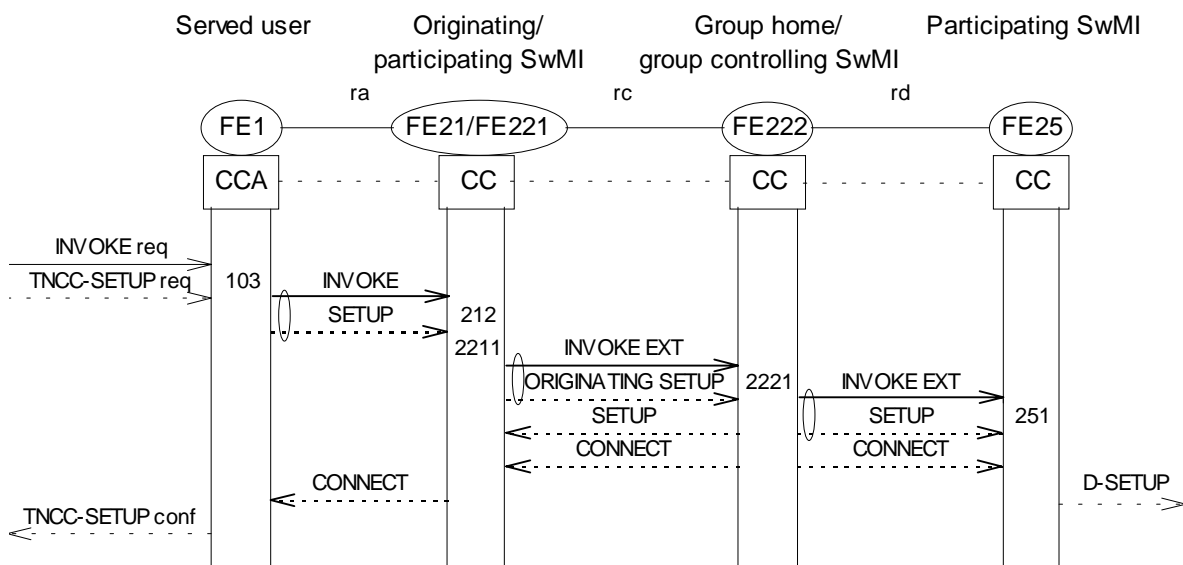

Figure 16: Basic invocation and operation of SS-AS over ISI - successful establishment of group call when the selected area definition is given in the originating SwMI

Figure 17 shows the information flow sequence for the successful SS-AS invocation and operation for an acknowledged group call when the group controlling checks that important group members for that call in a participating SwMI which lies partly within the selected area are within that area before successfully establishing the call.

NOTE 2: Figure 17 shows the case where the definition of the selected area number is given in the group home SwMI (again this is the basic case for a group call). A similar sequence would apply if the definition of the selected area number was given in the originating SwMI.

Other figures could also be derived from figure 17 in showing other cases for the originating SwMI than that where there are group members to be called in that SwMI and where that SwMI lies wholly within the selected area (e.g. originating SwMI lying only partly within the selected area).

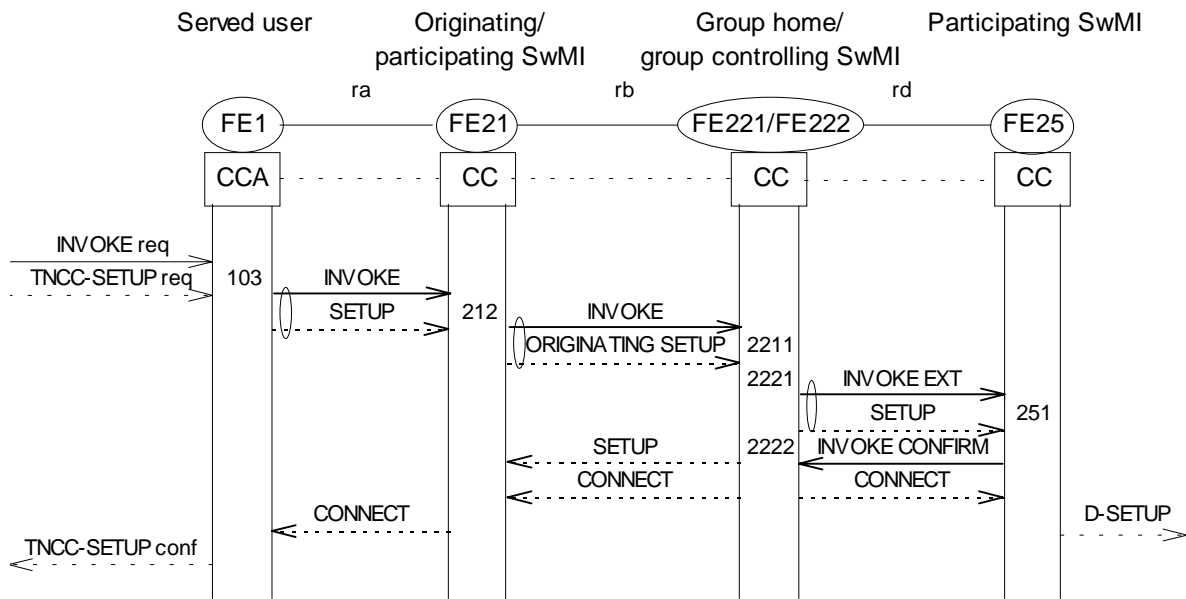
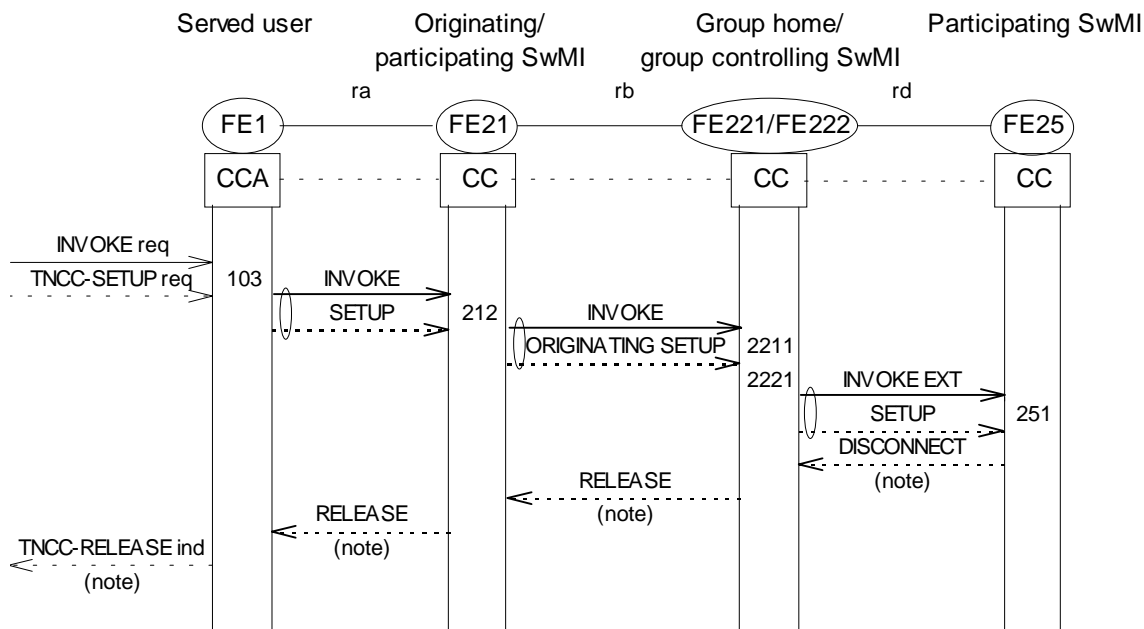

Figure 17: Basic invocation and operation of SS-AS over ISI - successful establishment of acknowledged group call when important users are in a participating SwMI lying partly within the selected area

5.4.3.2.2 Call attempt cleared by SS-AS

Figure 18 shows the information flow sequence for the successful SS-AS invocation and operation at set-up time results in the call attempt failure for an acknowledged group call in the case where FE25 in a participating SwMI would not be able to connect some important user.



NOTE: See note 2 in figure 11.

Figure 18: Basic invocation and operation of SS-AS over ISI resulting in group call attempt cleared because of successful operation

5.4.3.3 Operation for call restoration

Figure 19 shows the information flow sequence for the optional SS-AS operation when migration of a user already participating in the call occurs during a group call into a new SwMI which:

- lies partly within the selected area; or
- is completely outside selected area but the migrating user is the calling user or an other important user and the group controlling SwMI has decided to inhibit SS-AS operation for their call restorations.

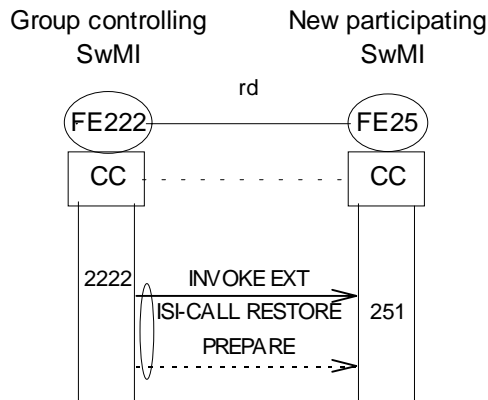

Figure 19: Optional operation of SS-AS when migration of a participating user occurs during a group call

5.4.3.4 SS-AS invocation failure

5.4.3.4.1 Group call attempt by calling user outside the selected area with SS-AS inhibition for that user

Figure 20 shows the information flow sequence when SS-AS invocation fails because the calling user is outside the selected area in the case where the originating SwMI lies partly within that area and:

- the group controlling SwMI has decided not to inhibit SS-AS operation for the calling user; or
- the group controlling SwMI has decided to inhibit SS-AS operation for the calling user but the originating SwMI does not support such inhibition.

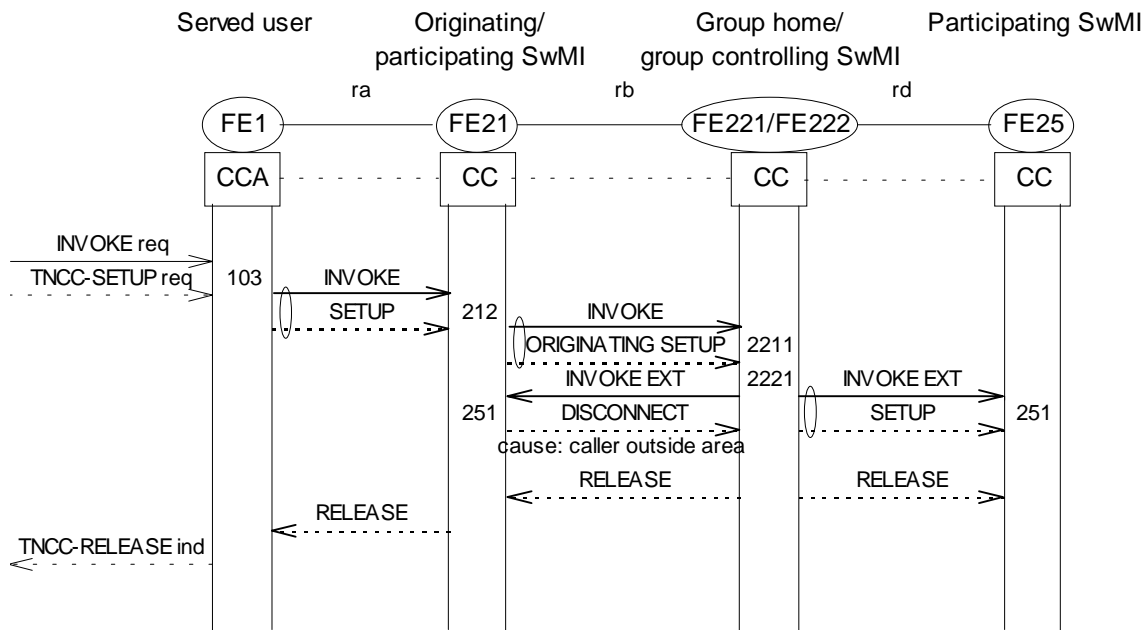

Figure 20: Failure of SS-AS invocation in a group call because the calling user is outside the selected area

5.4.3.4.2 Selected area not defined

Figure 21 shows the information flow sequence when SS-AS invocation fails because there is no area defined for the area number sent by the calling user in SS-AS invocation.

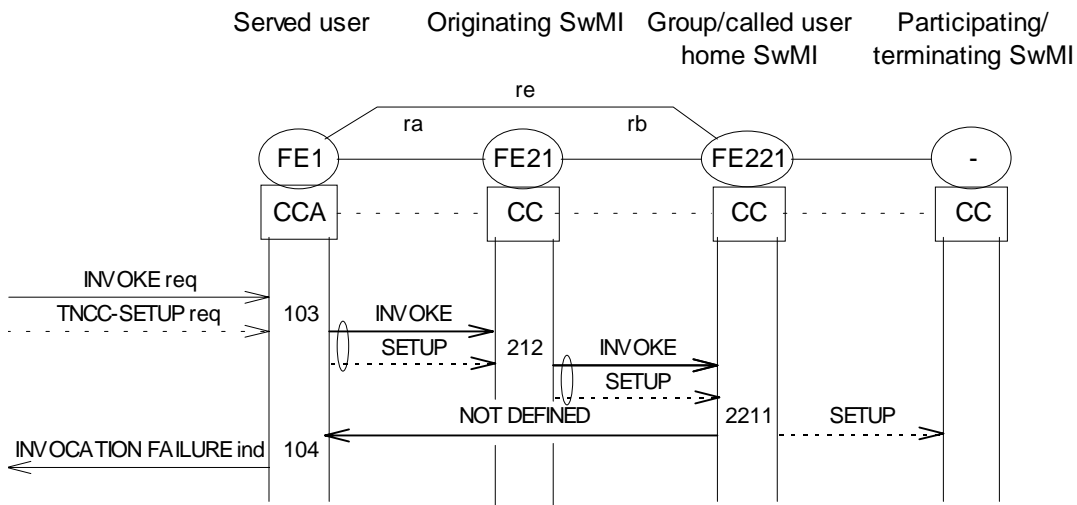

Figure 21: Failure of SS-AS invocation because the area number invoked is not defined

5.4.3.4.3 SS-AS not supported

Figure 22 shows the information flow sequence when SS-AS invocation fails because there is no FE25 functional entity.

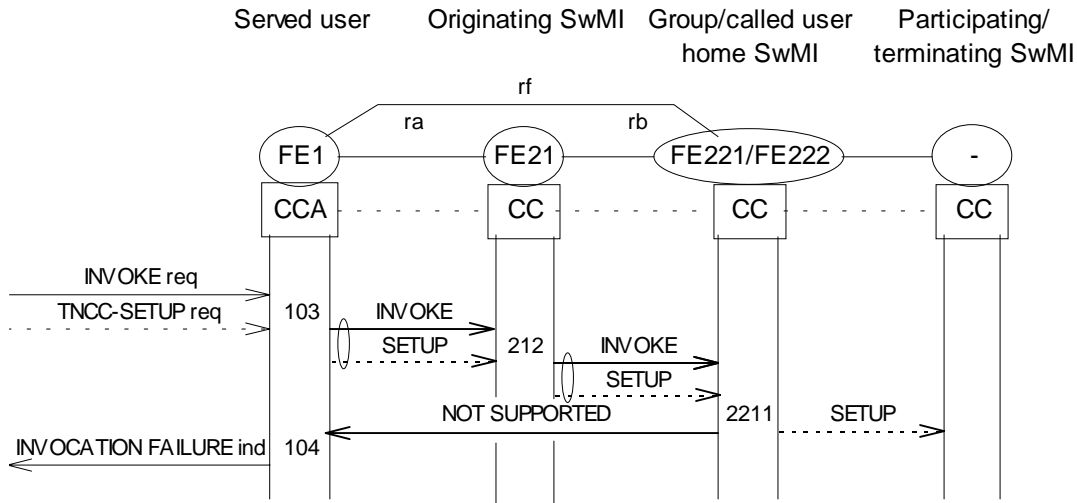
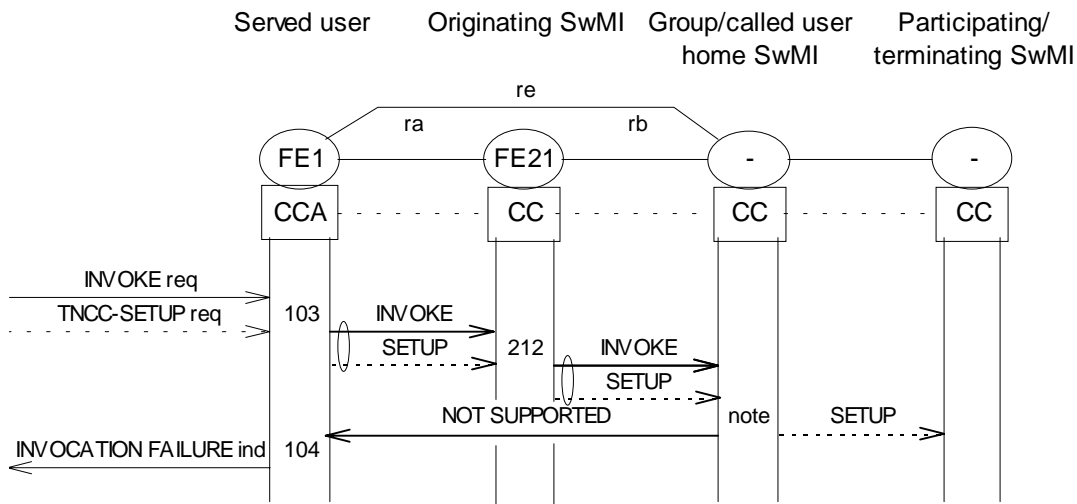

Figure 22: Failure of SS-AS invocation because of absence of FE25

Figure 23 shows the information flow sequence when SS-AS invocation fails because there is no FE22 functional entity.



NOTE: The information that there is no FE221 functional entity is not detected by any SS-AS functional entity: it originates from the SwMI with which such FE221 would be collocated if it existed in the scenario addressed in the figure, i.e. the group controlling SwMI for a group call, or the called user home SwMI for an individual call. That information is sent to the originating SwMI (in which FE21 is located) through ANF-ISISS. Formally the SS-AS information flow NOT SUPPORTED exists then only across relationship ra, to relay to FE1 the information received from ANF-ISISS (that there is no FE221 functional entity). However it has been shown as originating from the group controlling SwMI for a group call, or from the called user home SwMI for an individual call, to simplify the figure.

Figure 23: Failure of SS-AS invocation because of absence of FE221

5.4.3.4.4 SS-AS not subscribed to

Figure 24 shows the information flow sequence when SS-AS invocation fails because SS-AS has not been subscribed for the calling user.

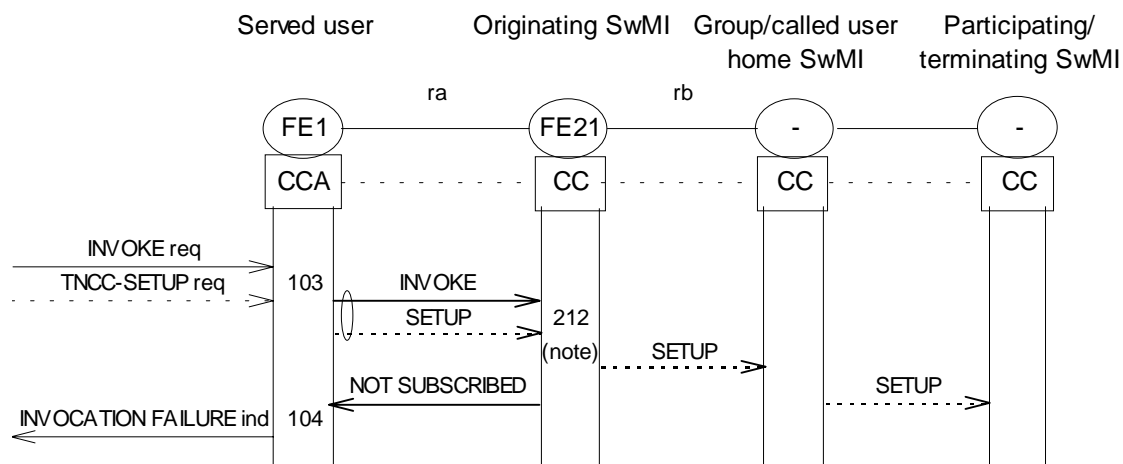

NOTE: The sequence shown in the figure shall always apply for all SS-AS invocations for individual calls (in the case of non-subscription). It shall only apply for SS-AS invocations for group calls when the originating SwMI has already been attached to the group (still in the case of non-subscription).

Figure 24: Failure of SS-AS invocation because of non-subscription

6 FE actions

These functional entity actions cover items presented in the previous scenarios. There may be other actions due to exceptional cases.

6.1 Functional Entity actions of FE1

- 101 Receive the area number definition(s) and deliver it/them to the user application.
- 102 Acknowledge the SS-AS definition assignment, if acknowledgement was requested.
- 103 Relay the SS-AS invocation received from the user application.
- 104 Relay the received NOT DEFINED, NOT SUBSCRIBED or NOT SUPPORTED information flow to the user application in changing it into the INVOCATION FAILURE indication primitive.

6.2 Functional Entity actions of FE20

- 201 On receipt of DEFINE request/indication information flow, verify the identity/identities, the corresponding subscription, the authorization for the request and the validity of the definition parameters. If the definition is authorized and valid, make the SS-AS definition to the SwMI and send the DEFINE ACK information flow to FE3. If the request is not authorized or valid, return an error indication to FE3.
- 202 On receipt of INTERROGATE request/indication information flow, verify that the request is allowed and its parameters are valid. If the request is authorized and valid, fetch the SS-AS data and send them in the INTERROGATE ACK information flow to FE3. If the request is not authorized or valid, return an error indication to FE3.

6.3 Functional Entity actions of FE21

- 211 If the authorized user requested it, assign the area number definition(s) to the served user(s) - for his(their) information. Receive the corresponding acknowledgement if sent by FE1.
- 212 Upon reception of the call request with the INVOKE request/indication information flow from FE1, check if SS-AS has been activated (i.e. subscribed to). If yes, pass that information flow to FE221 using the INVOKE request/indication information flow:
- as received, in the case of an individual call (reminder: in the basic SS-AS operation, FE21 and FE221 are collocated);
 - in complementing it, in the case of a group call, in indicating whether or not FE25 if collocated with the originating CC supports the inhibition of SS-AS operation for the calling user if he is outside the selected area.

If FE21 has found that SS-AS has not been activated (i.e. subscribed to), abort SS-AS invocation and inform the calling user about that using the NOT SUBSCRIBED request/indication information flow. Similarly, if FE21 is informed that there is no FE22 (e.g. the group controlling SwMI does not support SS-AS, in which case FE21 will be informed about it by a generic protocol mechanism, i.e. independent of SS-AS operation), inform the calling user about that using the NOT SUPPORTED request/indication information flow.

If SS-AS has not been activated, the basic call procedures shall apply as if SS-AS had not been invoked.

NOTE: Actually, the same will happen if the SwMI where FE221 is located does not support SS-AS.

6.4 Functional Entity actions of FE221

- 2211 Upon reception of the call request with the INVOKE request/indication information flow from FE21, verify the selected area number and fetch the corresponding selected area definition.

If no definition corresponding to the selected area number exists, abort SS-AS invocation and inform FE1 about that in sending the NOT DEFINED request/indication information flow. The establishment of the call shall then continue as if SS-AS had not been invoked.

If that definition exists, fetch the corresponding definition and send the INVOKE EXT request/indication information flow to FE221 including that definition.

6.5 Functional Entity actions of FE222

2221 In the case of individual call, determine how the terminating SwMI lies compared to the selected area. Depending on the result of that comparison, carry the following actions:

- if the called user has not migrated (i.e. the terminating SwMI coincides with the called user home SwMI), determine how the called user home SwMI lies compared to the selected area:
 - if it is partly or completely outside the selected area, create a FE25 collocated with FE222 (i.e. in the called user home SwMI) in sending to it the INVOKE EXT request/indication information flow;
 - if it lies wholly within the selected area, let the call establishment continue (i.e. if an FE25 was created, it would not have any function);
- if the called user has migrated (i.e. the terminating SwMI and the called user home SwMI are different), determine how the terminating SwMI lies compared to the selected area:
 - if it is completely outside the selected area, create an FE25 in the terminating SwMI in sending to it the INVOKE EXT request/indication information flow with an appropriate definition of the selected area (i.e. that the terminating SwMI can understand);
 - if it is only partly outside the selected area, check whether it supports SS-AS:
 - if yes, create an FE25 in the terminating SwMI in sending to it the INVOKE EXT request/indication information flow with a definition of the selected area appropriate to the terminating SwMI;
 - if not, abort SS-AS invocation and inform FE1 about that in sending the NOT SUPPORTED request/indication information flow. The basic call procedures shall then apply as if SS-AS had not been invoked;
 - if it lies wholly within the selected area, let the call establishment continue (i.e. if an FE25 was created, it would not have any function).

Once the individual call has been established, FE222 shall be cleared;

In the case of group call, create:

- an FE25 collocated with FE222 (i.e. in the group controlling SwMI) for all the participating SwMIs which are completely outside the selected area This shall also apply to the originating SwMI (if it is completely outside the selected area and) if: either
 - the originating SwMI is also a participating SwMI, i.e. users other than possibly the calling user -in the case where that user would be a group member- are attached to the group in that SwMI and the originating SwMI itself is attached to the group; or
 - there are no such users, else there are such users but the originating SwMI itself is not attached to the group, and FE222 has decided to establish the call in inhibiting SS-AS operation for the calling user (see note 1); and
- FE25s in all the participating SwMIs which support SS-AS and of which only part lies within the selected area, in sending to each one the INVOKE EXT request/indication information flow with an appropriate definition of the selected area (i.e. that such participating SwMI can understand). This shall also apply to the originating SwMI (if it supports SS-AS and if only part of it lies within the selected area and) if: either
 - the originating SwMI is also a participating SwMI; or
 - there are no users to be called (for the establishment of the group call) registered in the originating SwMI and: either:
 - FE222 has decided not to inhibit SS-AS operation for the calling user if he is outside the selected area; or
 - it has decided to actually inhibit SS-AS operation for the calling user if he is outside the selected area (see note 1) but the INVOKE request/indication information flow received from FE21 has indicated that a collocated FE25 would not support that inhibition.

NOTE 1: The criteria for FE222 to decide whether or not to inhibit SS-AS for the calling user are outside the scope of standardization.

NOTE 2: There is no need to create an FE25 for the originating SwMI or for any of the participating SwMIs wholly inside the selected area, since it would not have any function.

FE222 shall inform FE1 about participating SwMIs of which only part is within the selected area but which do not support SS-AS, in sending the NOT SUPPORTED request/indication information flow. This shall only apply to the originating SwMI if it is also a participating SwMI.

NOTE 3: Whether or not the call is established in a participating SwMI which lies only partly within the selected area and which does not support SS-AS is outside the scope of standardization.

2222 If it has instructed the originating SwMI to establish the call with no SS-AS inhibition for the calling user and if it has created a FE25 in that SwMI (i.e. the originating SwMI lies partly within the selected area), wait for receiving the INVOKE CONFIRM information flow from that FE25 before requesting the call control entity with which it is collocated to complete the establishment of the call.

In addition, in the case of an acknowledged group calls, wait for receiving the INVOKE CONFIRM information from the (created) FE25s which control other important users than the calling users to decide whether to let the establishment of the call continue.

2223 If the group controlling SwMI supports call restoration, when any of the users which were initially participating in the group call, including the calling user, migrates into a new SwMI (i.e. not an already existing participating SwMI) FE222 shall determine how that SwMI lies compared to the selected area. Depending on the result of that comparison, it shall carry the following actions:

- if the new SwMI is completely outside the selected area, if the migrating user is the calling user or an other important user and if no FE25 collocated with FE221 exists yet, create it.
- if only part of the new SwMI lies within the selected area, check whether it supports SS-AS:
 - if yes, create an FE25 in that new (participating) SwMI in sending to it the INVOKE EXT request/indication information flow with an appropriate definition of the selected area (i.e. that such participating SwMI can understand);
 - if not, abort SS-AS invocation for the new participating SwMI and inform FE1 about that in sending the NOT SUPPORTED request/indication information flow.
- if the new SwMI lies wholly within the selected area, allow call restoration to proceed in that SwMI without invoking SS-AS operation in that SwMI - i.e. without creating an FE25;

NOTE 4: When SS-AS invocation is aborted by action 2222, the call restoration procedure will continue as if SS-AS had not been invoked.

6.6 Functional Entity actions of FE25

251 Receive the INVOKE EXT request/indication information flow from FE222 and check if it supports the type of definition of its element selected area.

If it does not support it, send the NOT SUPPORTED request/indication information flow to FE222, with the corresponding cause.

If it supports it, in the case of an individual call, check whether the called user is within that selected area or not. If not, request the call control entity with which it is collocated to clear the call in indicating to the calling user that the call attempt has failed because of SS-AS operation.

If it supports it, in the case of a group call, restrict the establishment of the call to that selected area. In addition the following requirements shall apply to the FE25 operating in the originating SwMI:

- if FE222 has requested the inhibition of SS-AS operation for the calling user:
 - that FE25 should inhibit SS-AS operation for the calling user;
 - if it cannot do or if FE222 has requested SS-AS operation for the calling user, that FE25 shall request the call control entity with which it is collocated to clear the call when it finds out that the calling user is outside the selected area in giving the corresponding reason to the calling user;
- if FE222 has requested SS-AS operation for the calling user, FE25 shall inform it whether the calling user is within the selected area in sending the INVOKE CONFIRM information flow.

A further requirement shall apply to the FE25s operating in the participating SwMIs in the case of acknowledged group call: they shall inform FE222 about the important users (other than the calling user) within the selected area that they control in sending the INVOKE CONFIRM information flow. All FE25s (i.e. in the group controlling SwMI, in the participating SwMIs and possibly in the originating SwMI) shall continue to operate during the call. If instructed by FE222 (in the INVOKE EXT information flow that each has received) they should inhibit SS-AS operation for the important users which were initially participating in the call, including the calling user, when such users roam (i.e. within the same participating SwMI) or migrate outside the selected area.

NOTE 1: When a user migrates: either

- it is into an existing participating SwMI, then FE25 already exists for that SwMI unless it lies wholly within the selected area; or
- it is into a new participating SwMI, then a new FE25 is created by FE222 for that SwMI unless it lies wholly within the selected area.

NOTE 2: If FE25 does not support that recommendation, when any of the initial participating users, including the calling user, changes location to a cell outside the selected area, the call restoration attempt of that user will fail. If such user happens to be an important user, notably the owner of the group call at that time, the basic group call procedures will apply.

If the call cannot be restored for the calling user, it should be indicated to FE1.

NOTE 3: If FE25 supports the above recommendation, it would bar only the users who attempt to join the group call later (e.g. through the supplementary service Late Entry (SS-LE)).

6.7 Functional Entity actions of FE3

- 301 Detect the user application request for defining a SS-AS definition and send to FE20 the corresponding DEFINE request/indication information flow.
- 302 Deliver to the user application the information received in DEFINE ACK.
- 303 Detect the user application request for interrogation for the definition of the area numbers for a given individual subscriber or for a group and send to FE20 the corresponding INTERROGATE request/indication information flow.
- 304 Deliver to the user application the information received in INTERROGATE ACK.

7 Allocation of functional entities to physical equipment

The possible scenarios for the allocation of functional entities to SwMIs and MS/LSs are shown in the following tables:

- table 12 for the case of individual call;
- table 13 for the case of group call;
- table 14 for the management of SS-AS.

Table 12: Scenarios for the allocation of FEs to physical equipment/SwMIs in the case of individual call

	FE1	FE21	FE221 (note)	FE222	FE25
Scenario 1	MS/LS	Originating SwMI	Originating SwMI	Called user home SwMI	Called user home SwMI
Scenario 2	MS/LS	Originating SwMI	Originating SwMI	Called user home SwMI	Terminating SwMI
Scenario 3	MS/LS	Originating SwMI	Called user home SwMI	Called user home SwMI	Called user home SwMI
Scenario 4	MS/LS	Originating SwMI	Called user home SwMI	Called user home SwMI	Terminating SwMI
NOTE:	By definition, FE22 is located at the SwMI in which the definition of the selected area number invoked will be given.				

Table 13: Scenarios for the allocation of FEs to physical equipment/SwMIs in the case of group call

	FE1	FE21	FE221	FE222	FE25
Scenario 1	MS/LS	Originating SwMI	Group home SwMI	Group controlling SwMI	Group controlling SwMI (note)
Scenario 2	MS/LS	Originating SwMI	Group home SwMI	Group controlling SwMI	Participating SwMIs
Scenario 3	MS/LS	Originating SwMI	Group home SwMI	Group controlling SwMI	Group controlling SwMI (note) and participating SwMIs
Scenario 4	MS/LS	Originating SwMI	Originating SwMI	Group controlling SwMI	Group controlling SwMI (note)
Scenario 5	MS/LS	Originating SwMI	Originating SwMI	Group controlling SwMI	Participating SwMIs
Scenario 6	MS/LS	Originating SwMI	Originating SwMI	Group controlling SwMI	Group controlling SwMI (note) and participating SwMIs
NOTE:	FE25 is located at the group controlling SwMI either for group members registered in that SwMI or when the definition of the area number in the SS-AS invocation completely excludes some participating SwMI(s).				

NOTE 1: The splitting of FE21 into two functional entities mentioned in note 2 of subclause 4.3 has not been taken into account in table 13.

Table 14: Scenarios for the allocation of FEs to physical equipment/SwMIs in the case of management

	FE3	FE20
Scenario 1	MS/LS	Home SwMI of managed served user/group
Scenario 2	Home SwMI of managed served user/group (note)	Home SwMI of managed served user/group
NOTE:	This scenario is outside the scope of SS-AS standardization.	

NOTE 2: The possibility of FE20 being allocated to the SwMI where the managed served user is currently registered has been ruled out. This means that when an FE3 functional entity limited to the definition of SS-AS selectable areas is allocated to the served user MS/LS, the definition requests from that user will be addressed to his home SwMI (who will then invoke ANF-ISIMM to download them to the SwMI where that user is currently registered).

8 Interworking considerations

The case where SS-AS extends to several TETRA networks has already been taken into account in the preceding clauses, except for the exchange of information related to the support and the subscription of SS-AS with the related supplementary service profile information when an individual subscriber migrates into a SwMI different from his home SwMI or when a SwMI different from the home SwMI of a group is attached to that group. As defined in ETS 300 392-3-5 [6], such exchange is ensured:

- by the PROFILE UPDATE request/indication information flow from FE20, which contains the information whether SS-AS has been subscribed to for the individual subscriber (which implies that SS-AS is supported by the concerned MS) or for the group. If so, the corresponding PROFILE UPDATE response/confirmation information flow contains the information whether SS-AS is supported by the visited SwMI:
 - as originating SwMI in the case of individual subscriber migration. It is then sent by FE21; or
 - as originating SwMI or participating SwMI in the case of group attachment. It is then sent by FE21 or FE25 respectively;
- by the SS-PROFILE UPDATE request/indication and response/confirmation information flows, containing the SS-AS profile. Again, those information flows are exchanged between FE20 and FE21 in the case of migration of an individual subscriber and between FE20 and FE21 or FE25 in the case of group attachment.

More precisely, the information about the SS-AS subscription is carried by the sub-element SS-information in the elements group or individual basic migration profiles in the PROFILE UPDATE request/indication information flow, while the response about the SS-AS support by the visited SwMI is carried by the sub-element SS-information response in the elements group or individual basic migration profiles in the PROFILE UPDATE response/confirmation information flow.

Normally, when SS-AS has been subscribed to for an individual subscriber, his home SwMI shall download the corresponding SS-AS definitions to the visited SwMI. The same should then apply when the definitions of one or more area numbers for that individual subscriber are updated. The sub-sub-element SS status of the above mentioned sub-element SS-information shall then take the value corresponding to SS-AS subscribed to with SS-migration profile. However, it may also happen that no SS-AS definition is downloaded to the visited SwMI. The sub-sub-element SS status of the above mentioned sub-element SS-information shall then take the value corresponding to SS-AS subscribed for without SS-migration profile. The visited SwMI should then use its default SS-AS profile.

If a SS-AS profile is to be downloaded by the home SwMI to the visited SwMI, this will be done using the sub-element SS-migration profile (original) in the SS-PROFILE UPDATE request/indication information flow. Table 15 lists the SS-AS pieces of information which shall then be included in the sub-sub-element SS-ISI-PROFILE (original) of that sub-element SS-migration profile (original).

Table 15: SS-AS pieces of information in SS-ISI-PROFILE (original) for individual subscriber migration

Pieces of information	Type
Area number	M (note 1)
Selectable area definition	M (note 2)
NOTE 1: Shall be repeated for each value corresponding to a different area number defined.	
NOTE 2: Shall be repeated as many times as the element area number.	

When SS-AS has been subscribed for a group, its home SwMI shall not download the corresponding SS-AS definitions to the SwMI which attaches to the group. The sub-sub-element SS status of the above mentioned sub-element SS-information shall thus take the value corresponding to SS-AS subscribed to without SS-migration profile. However the SwMI which attaches to the group (and which can thus be the originating SwMI or a participating SwMI in a call to that group) may inform the group controlling SwMI about the types of area definition which it supports (in order that the group controlling SwMI avoid using a type of definition for the selected area that the originating/participating SwMI does not support in the INVOKE EXT information flow). To (optionally) send that information, that SwMI which attaches to the group shall use the sub-element SS-migration profile (temporary) in the SS-PROFILE UPDATE request/indication information flow. Table 16 lists the SS-AS pieces of information which shall then be included in the sub-sub-element SS-ISI-PROFILE (temporary) of that sub-element SS-migration profile (temporary).

**Table 16: SS-AS pieces of information in SS-ISI-PROFILE (temporary)
for group attachment**

Pieces of information	Type
Types of area definitions supported	M (note)
NOTE: Shall be repeated for each type of area definition supported.	

NOTE: Actually the types of area definitions supported by a SwMI will generally be independent of the group to which this SwMI may be attached, i.e. that SwMI will support the same types of area definitions for all those groups. Furthermore it will also support the same types of selectable areas defined for individual subscribers (such definitions being passed by the home SwMI of that subscriber to his visiting SwMI in the SS-PROFILE UPDATE request/indication information flow as described above).

Therefore one might be entitled to consider that a general mechanism for the exchange of the information content of table 16 between SwMIs should supersede that defined above when a SwMI is attached to a specific group. Actually such mechanism would be all the more desirable because it would avoid that the home SwMI of a migrating individual subscriber download a SS-AS profile to the visited SwMI using types of selectable area definitions (see table 15) not supported by that visited SwMI - using the sub-element SS-migration profile (original) in the SS-PROFILE UPDATE request/indication information flow as defined above.

However such a general mechanism for the exchange of the information content of table 16 between SwMIs has not been standardized (at the time of writing the present ETS). On the other hand, nothing prevents a SwMI operator to input that information for a number of SwMIs in a data table for his SwMI, nor that such information be exchanged using proprietary methods.

As to the case of interworking with PSTN, ISDN or PISN, any invocation of SS-AS for an external outgoing call shall be ignored.

History

Document history	
December 1999	Public Enquiry PE 200016: 1999-12-22 to 2000-04-21