



EUROPEAN
TELECOMMUNICATION
STANDARD

FINAL DRAFT

ETS 300 392-11-7

February 2000

Source: TETRA

Reference: DE/TETRA-03001-11-07

ICS: 33.020

Key words: data, radio, speech, stage 2, supplementary service, TETRA, V+D

**Terrestrial Trunked Radio (TETRA);
Voice plus Data (V+D);
Part 11: Supplementary services stage 2;
Sub-part 7: Short Number Addressing (SNA)**

ETSI

European Telecommunications Standards Institute

ETSI Secretariat

Postal address: F-06921 Sophia Antipolis CEDEX - FRANCE

Office address: 650 Route des Lucioles - Sophia Antipolis - Valbonne - FRANCE

Internet: secretariat@etsi.fr - <http://www.etsi.org>

Tel.: +33 4 92 94 42 00 - Fax: +33 4 93 65 47 16

Copyright Notification: No part may be reproduced except as authorized by written permission. The copyright and the foregoing restriction extend to reproduction in all media.

© European Telecommunications Standards Institute 2000. All rights reserved.

Contents

Foreword.....		5
1	Scope	7
2	Normative References.....	7
3	Definitions and abbreviations	8
3.1	Definitions	8
3.2	Abbreviations	8
4	Functional model	8
4.1	Functional model description	8
4.2	Description of functional entities	9
4.2.1	Served user functional entity, FE1	9
4.2.2	Served user SwMI functional entity, FE21	9
4.2.3	Served user home SwMI FE, FE20	10
4.2.4	Authorized user functional entity, FE3	10
4.3	Relationship of functional model to basic call functional model	10
5	Information flows	10
5.1	Definition of information flows	10
5.1.1	ASSIGN	11
5.1.2	ASSIGN ACK	12
5.1.3	DEFINE	13
5.1.4	DEFINE ACK	15
5.1.5	INTERROGATE	16
5.1.6	INTERROGATE ACK	16
5.1.7	INVOKE	18
5.1.8	INVOCATION FAILURE	18
5.1.9	SS SUPPORT INFO	19
5.1.10	Information flow elements	20
5.2	Relationship of information flows to basic call information flows	20
5.3	Service primitives	20
5.4	Examples of information flow sequences	21
5.4.1	Definition.....	21
5.4.1.1	Definition with no assignment	21
5.4.1.2	Definition with assignment in visited SwMI	22
5.4.1.3	Definition including control of supplementary services rejected by visited SwMI	22
5.4.2	Interrogation	23
5.4.3	Invocation and operation	23
5.4.3.1	Basic invocation and operation with successful call establishment.....	23
5.4.3.2	SS-SNA invocation failure.....	24
6	FE actions.....	24
6.1	Functional Entity actions of FE1	24
6.2	Functional Entity actions of FE20.....	25
6.3	Functional Entity actions of FE21.....	25
6.4	Functional Entity actions of FE3.....	26
7	Allocation of functional entities to physical equipment	26
8	Interworking considerations.....	27
	History.....	30

Blank page

Foreword

This final draft European Telecommunication Standard (ETS) has been produced by the ETSI Project Terrestrial Trunked Radio (TETRA), and is now submitted for the Voting phase of the ETSI standards approval procedure.

This ETS consists of 14 parts as follows:

- Part 1: "General network design";
- Part 2: "Air Interface (AI)";
- Part 3: "Interworking at the Inter-System Interface (ISI)";
- Part 4: " Gateways basic operation";
- Part 5: "Peripheral Equipment Interface (PEI)";
- Part 6: "Line connected Station (LS)";
- Part 7: "Security";
- Part 8: "Network management services";
- Part 9: "General requirements for supplementary services";
- Part 10: "Supplementary services stage 1";
- Part 11: "Supplementary services stage 2";**
- Part 12: "Supplementary services stage 3";
- Part 13: "SDL model of the Air Interface (AI)";
- Part 14: "Protocol Implementation Conformance Statement (PICS) proforma specification".

Proposed transposition dates	
Date of latest announcement of this ETS (doa):	3 months after ETSI publication
Date of latest publication of new National Standard or endorsement of this ETS (dop/e):	6 months after doa
Date of withdrawal of any conflicting National Standard (dow):	6 months after doa

Blank page

1 Scope

This ETS specifies the stage 2 description of the Supplementary Service Short Number Addressing (SS-SNA) for the Terrestrial Trunked Radio (TETRA).

SS-SNA enables the served user to send an abbreviated number instead of a full identity to the infrastructure and additionally SNA may either invoke or suppress other supplementary services.

Man-Machine Interface (MMI) and charging principles are outside of the scope of this ETS.

Supplementary service specifications are produced in three stages according to the method defined in ITU-T Recommendation I.130 [1]. The stage 2 description identifies the functional capabilities and the information flows needed to support the supplementary service as specified in its stage 1 description (see ETS 300 392-10-7 [6]). The stage 2 description is followed by the stage 3 description, which specifies the protocols at the air interface and at the various Inter-System Interfaces (ISI) to support the service.

This document is applicable to TETRA Voice plus Data terminal equipment and networks.

2 Normative References

This ETS incorporates by dated and undated reference, provisions from other publications. These normative references are cited at the appropriate places in the text and the publications are listed hereafter. For dated references, subsequent amendments to or revisions of any of these publications apply to this ETS only when incorporated in it by amendment or revision. For undated references the latest edition of the publication referred to applies.

- [1] ITU-T Recommendation I.130 (1993): "Method for the characterization of telecommunication services supported by an ISDN and network capabilities of an ISDN".
- [2] ETS 300 392-1: "Terrestrial Trunked Radio (TETRA); Voice plus Data (V+D); Part 1: General network design".
- [3] ETS 300 392-2: "Terrestrial Trunked Radio (TETRA); Voice plus Data (V+D); Part 2: Air Interface (AI)".
- [4] ETS 300 392-3-5: "Terrestrial Trunked Radio (TETRA); Voice plus Data (V+D); Part 3: Interworking at the Inter-System Interface (ISI); Sub-part 5: Additional Network Feature for Mobility Management (ANF-ISIMM)".
- [5] ETS 300 392-9: "Terrestrial Trunked Radio (TETRA); Voice plus Data (V+D); Part 9: General requirements for supplementary services".
- [6] ETS 300 392-10-7: "Terrestrial Trunked Radio (TETRA); Voice plus Data (V+D); Part 10: Supplementary services stage 1; Sub-part 7: Short number addressing".
- [7] ETS 300 392-12-7: "Terrestrial Trunked Radio (TETRA); Voice plus Data (V+D); Part 12: Supplementary services stage 3; Sub-part 7: Short Number Addressing (SNA)".
- [8] ISO/IEC 11574: "Information technology; Telecommunications and information exchange between systems; Private Integrated Services Network; Circuit-mode 64 kbit/s bearer services; Service description, functional capabilities and information flows".

3 Definitions and abbreviations

3.1 Definitions

For the purposes of this ETS, the definitions of ETS 300 392-9 [5] apply, in addition to the following:

authorized user: identified user who is allowed to define SS-SNA short numbers for individual subscribers and/or interrogate the infrastructure about the SS-SNA short numbers defined for individual subscribers

served user: individual user for whom SS-SNA supplementary service has been subscribed. That user can thus successfully invoke the supplementary service. Short numbers may be defined for that user (by the authorized user or by other means outside the scope of this ETS), and possibly assigned to his MS/LS. Interrogation may also be placed about those definitions (by the authorized user or by other means outside the scope of this ETS)

served user SwMI: SwMI where the served user is currently registered. The served user SwMI is the originating SwMI in a call

3.2 Abbreviations

For the purposes of this ETS, the following abbreviations apply:

CC	Basic Service Call Control functional entity
CCA	Basic Service Call Control functional entity agent

NOTE: CC and CCA are applied as defined in ISO/IEC 11574 [8].

ANF-ISIGC	Additional Network Feature - Inter-System Interface Group Call
ANF-ISIIC	Additional Network Feature - Inter-System Interface Individual Call
ANF-ISIMM	Additional Network Feature - Inter-System Interface Mobility Management
ANF-ISISS	Additional Network Feature - Inter-System Interface Supplementary Service
FE	Functional Entity
GTSI	Group TETRA Subscriber Identity
ISI	Inter-System Interface
ITSI	Individual TETRA Subscriber Identity
LS	Line Station
MS	Mobile Station
SDL	Specification an Description Language
SNA	Short Number Addressing
SS	Supplementary Service

NOTE: The abbreviation SS is only used when referring to a specific supplementary service (e.g. SS-SNA).

SwMI	Switching and Management Infrastructure
------	---

4 Functional model

4.1 Functional model description

The functional model shall comprise the following Functional Entities (FEs):

FE1	Served user functional entity;
FE21	Served user SwMI FE;
FE20	Managed user home SwMI FE;
FE3	Authorized user functional entity.

The following relationships shall exist between these FEs:

ra	between FE1 and FE21;
rb	between FE3 and FE20.

Figure 1 shows these FEs and relationships for the basic operational part of SS-SNA.

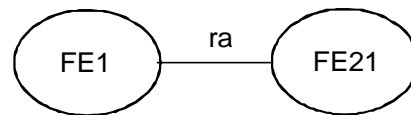
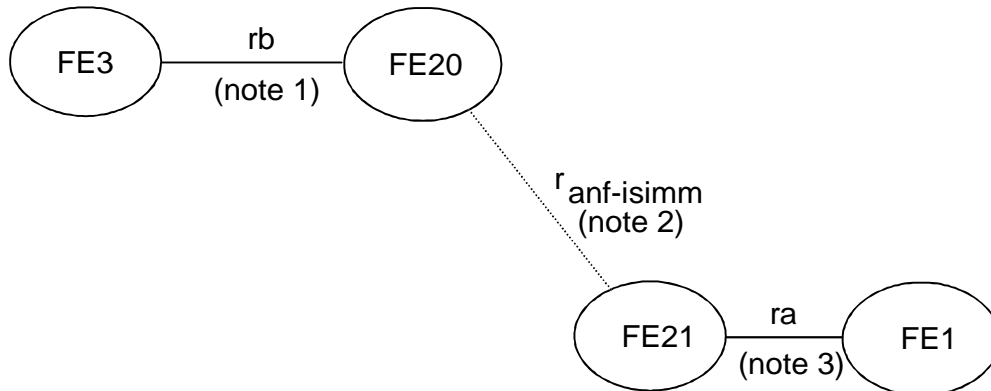

Figure 1: Functional model for the operational part of SS-SNA

Figure 2 shows these FEs and relationships for the management part of SS-SNA.



- NOTE 1: All requests issued by the authorized user for an SS-SNA managed user are to be addressed to the home SwMI of this managed user.
- NOTE 2: This holds even if the calling user is given a partial authorized user capability to define short numbers, or place interrogation about such definitions.
- NOTE 3: The relationship between FE20 and FE21 is an ANF-ISIMM relationship, across which the SS-SNA profile is exchanged.
- NOTE 4: The relationship ra is shown on the figure in case the definition is assigned (i.e. downloaded) to the served user.

Figure 2: Functional model for the management part of SS-SNA

4.2 Description of functional entities

4.2.1 Served user functional entity, FE1

FE1 is the functional entity that serves the calling user for the invocation of SS-SNA.

In addition, FE1 handles the reception of the short number definitions from FE21 and the possible sending of their acknowledgement to FE21.

4.2.2 Served user SwMI functional entity, FE21

When it receives a SS-SNA invocation from FE1 (at call set-up time), FE21 initially determines whether SS-SNA has been activated (i.e. subscribed) and if so determines the GTSI or ITSI corresponding to the SNA value invoked. In the case of a short number corresponding to an external user, FE21 shall also determine the external subscriber number.

In addition, if instructed by FE20, FE21 downloads the SS-SNA definition (received as part of ANF-ISIMM - see ETS 300 392-3-5 [4]) and receives the possible corresponding acknowledgements when sent by FE1.

4.2.3 Served user home SwMI FE, FE20

FE20 receives and processes the optional definition requests received from FE3.

NOTE: When the served user has migrated and is registered in a visited SwMI, the SS-SNA definition stored by FE20 will be passed to FE21 in that SwMI by ANF-ISIMM (see ETS 300 392-3-5 [4]), possibly with the request to pass it to the served user (in the case when the authorized user has requested that such definition be assigned to the served user).

FE20 also receives and processes the optional interrogation requests received from FE3.

4.2.4 Authorized user functional entity, FE3

FE3 handles the sending of the optional definition and/or interrogation requests passed by the authorized user application, and the reception of the optional definition and/or interrogation responses from FE20, in passing them to the authorized user application.

4.3 Relationship of functional model to basic call functional model

Although no formal models have been defined for basic individual call nor for basic group call, those models can be readily derived from the PISN model for basic call, in ISO/IEC 11574 [8].

Being call unrelated, the assignment, definition and interrogation procedures are independent of CC or CCA.

FE1 shall be collocated with the calling user CCA.

FE21 shall be collocated with the originating CC.

Figure 3 shows the relationship between the models for SS-SNA invocation and operation and for the basic group call or the basic individual call.

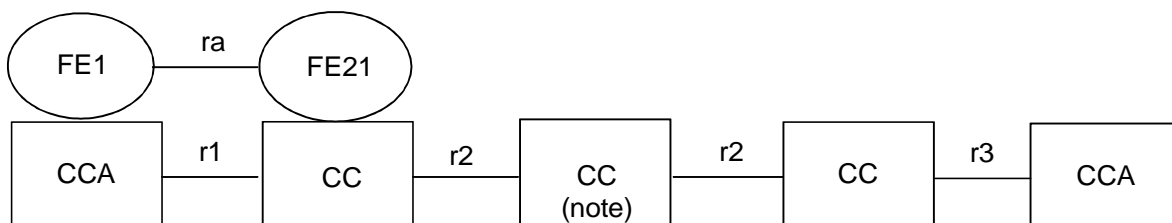

NOTE: It is possible that no intermediate CC be present (i.e. when the called user -to whom the CCA on the right is associated- is registered in his home SwMI and when no transit Private Integrated (services) Network Exchanges -PINXs- are present). That comment holds for both individual call and group call.

Figure 3: Relationship between models for SS-SNA and basic group call or basic individual call

5 Information flows

5.1 Definition of information flows

In the tables listing the information elements in information flows, the column headed "Type" indicates which of these elements are Mandatory (M), which are Optional (O) and which are Conditional (C).

5.1.1 ASSIGN

ASSIGN is an unconfirmed information flow across relationship ra from FE21 to FE1 which informs the SS-SNA served user MS/LS about the GTSI or ITSI, plus possibly the external subscriber number and the control of specific supplementary services, corresponding to a SS-SNA short number. It also provides for the control of the acknowledgement of the reception of that information by the served user MS/LS.

Table 1 lists the elements within the ASSIGN information flow.

Table 1: Contents of ASSIGN

Element	Type
Short number	M (note 1)
New definition or deletion	M (note 2)
GTSI/ITSI	C (note 3)
External subscriber number	O (note 4)
SS-COLP invocation	C (note 3)
SS-TPI invocation	C (notes 3 and 5)
Delivery of priority levels of talking/sending party speech/transmission requests	C (note 6)
Delivery of talking/sending party mnemonic name	C (note 6)
Overriding of SS-CAD invocation for incoming calls	C (note 3)
Overriding of SS-BIC invocation	C (note 7)
Overriding of SS-CAD invocation for outgoing calls	C (note 3)
Overriding of SS-BOC invocation	C (note 8)
Overriding of SS-CLIR invocation	C (notes 2 and 9)
Limitations on other supplementary service invocations/ invocation overriding	O (note 10)
Acknowledgement requested from FE1(s)	O
NOTE 1:	May be repeated.
NOTE 2:	Shall be repeated as many times as the element short number.
NOTE 3:	Shall be present when the value of the element new definition or deletion corresponds to new definition. Shall then be repeated together with that element.
NOTE 4:	Shall be present when the short number corresponds to an external number. The GTSI/ITSI element shall then be the ITSI of the corresponding gateway. Shall then be repeated together with that element.
NOTE 5:	The value of that element may correspond to the invocation of SS-TPI only when the element short number corresponds to an ITSI. (since in case of group call, SS-TPI is not invoked for the calling user but for the group).
NOTE 6:	Conditional on the value of the element SS-TPI invocation corresponding to the invocation of SS-TPI (see note 5).
NOTE 7:	Shall be present only when the value of the element overriding of SS-CAD invocation for incoming calls corresponds to such overriding for the short number being defined (since SS-CAD for incoming calls overrides SS-BIC). Shall then be repeated together with each corresponding short number element.
NOTE 8:	Shall be present only when the value of the element overriding of SS-CAD invocation for outgoing calls corresponds to such overriding for the short number being defined (since SS-CAD for outgoing calls overrides SS-BOC). Shall then be repeated together with each corresponding short number element.
NOTE 9:	Shall apply for the calls made using the SS-SNA short number to the definition of which that element applies, in case SS-CLIR would otherwise have automatically been invoked for the served user.
NOTE 10:	The element limitations on other supplementary service invocations/ invocation overriding should be present when the definition of at least one short number which is being sent in the present ASSIGN is such that if the served user invokes SS-SNA using that short number, such invocation would at the same time: <ul style="list-style-type: none"> - invoke SS-COLP or SS-TPI while the served user (visited) SwMI does not support the supplementary service; - invoke of SS-TPI with a subscription option while the served user (visited) SwMI does not support such option; or - request the overriding of SS-CAD for outgoing calls or of SS-BOC while the served user (visited) SwMI would not accept that request.

The element short number identifies the SS-SNA short number the definition of which follows in, or is being by, the ASSIGN request/indication information sent. The element new definition or deletion indicates whether the short number is being defined or if its definition has been deleted.

The element GTSI/ITSI shall contain the identity either of the group or of the individual subscriber (or gateway) respectively corresponding to the preceding element short number. The GTSI of the group and the ITSI of the individual subscriber are defined in subclause 7.2.2 of ETS 300 392-1 [2].

When present, the element external subscriber number shall indicate the number to be called in the external (interworking) network by the SwMI gateway with the ITSI indicated by the preceding element.

The elements related to the invocation of other supplementary services shall control the invocation of those supplementary services together with that of the corresponding short number, at least if they are supported by the served user SwMI (as originating SwMI) when that SwMI is different from the served user home SwMI. The latter information shall be given by the value of the element limitations on other supplementary service invocations/ invocation overriding.

The elements related to the overriding of the invocation of other supplementary services shall bar such invocation (in the case where it would have taken place automatically otherwise). Such barring may not be accepted by the served user SwMI (as originating SwMI) when that SwMI is different from the served user home SwMI. As in the case of the preceding paragraph, the latter information shall be given by the value of the element limitations on other supplementary service invocations/ invocation overriding.

When an acknowledgement is requested from FE1 (i.e. in the served user MS/LS) by the element "acknowledgement requested from FE1(s)", it shall be sent by the ASSIGN ACK information flow (see subclause 5.1.2), which may then be considered as a response/confirmation information flow corresponding to the ASSIGN request/indication information flow.

The served user shall always be an individual subscriber (and never a group).

NOTE: Thereby the ASSIGN request/indication information flow will generally be addressed individually to FE1 (i.e. in the served user MS/LS). However in the specific case where one or more SS-SNA short numbers have the same definitions for all members of a group, the ASSIGN request/indication information flow may be sent using group addressing.

5.1.2 ASSIGN ACK

ASSIGN ACK is actually the response/confirmation information flow corresponding to the ASSIGN request/indication information flow. It is thus across relationship ra from FE1 to FE21. That flow is used to inform FE21 about the completion of the corresponding assignment request.

NOTE 1: The definition of how a given ASSIGN ACK information flow relates to the corresponding ASSIGN information flow is outside the scope of the stage 2 description. One such ASSIGN ACK request/indication information flow may be sent to acknowledge multiple ASSIGN request/indication information flows sent recently enough. On the contrary more than one ASSIGN ACK request/indication information flow may be sent to acknowledge a single ASSIGN request/indication information flow, notably in the case where the definition of some short numbers has been successful and that of others, not (because the corresponding GTSI/ITSI did not exist).

Table 2 defines the content of the ASSIGN ACK information flow.

Table 2: Contents of ASSIGN ACK

Element	Type
Short number	M (note)
Assignment result	M
NOTE: May be repeated.	

NOTE 2: In the specific case where the ASSIGN request/indication information flow has been sent using group addressing (see note in subclause 5.1.1) with acknowledgement requested from FE1(s), the corresponding ASSIGN ACK information flow will be sent by the FE1s of each member of the group - except those which did not receive the ASSIGN information flow.

5.1.3 DEFINE

DEFINE is an unconfirmed information flow across relationship rb from FE3 to FE20, which defines the ITSI or GTSI, plus possibly the external subscriber number and the control of specific supplementary services, corresponding to a SS-SNA short number for the served user(s). It also controls the assignment of that definition to the served user MS/LS(s).

NOTE 1: The response/confirmation information flow corresponding to the DEFINE request/indication information flow is DEFINE ACK (see subclause 5.1.4).

Table 3 lists the elements within the DEFINE information flow.

Table 3: Contents of DEFINE

Element	Type
Served user	M (note 1)
Short number	M (note 2)
New definition or deletion	M (note 3)
GTSI/ITSI	C (note 4)
External subscriber number	O (note 5)
SS-COLP invocation	C (note 4)
SS-TPI invocation	C (notes 4 and 6)
Delivery of priority levels of talking/sending party speech/transmission requests	C (note 7)
Delivery of talking/sending party mnemonic name	C (note 7)
Overriding of SS-CAD invocation for incoming calls	C (note 4)
Overriding of SS-BIC invocation	C (note 8)
Overriding of SS-CAD invocation for outgoing calls	C (note 4)
Overriding of SS-BOC invocation	C (note 9)
Overriding of SS-CLIR invocation	C (notes 4 and 10)
Assignment to FE1(s) requested	O
Acknowledgement requested from FE1(s)	O (note 11)
NOTE 1:	May be repeated, for other served users for whom the definition(s) of the short numbers in that (specific) DEFINE request/indication information flow applies(apply), including the invocation or invocation by-pass of supplementary services.
NOTE 2:	May be repeated.
NOTE 3:	Shall be repeated as many times as the element short number.
NOTE 4:	Shall be present when the value of the element new definition or deletion corresponds to new definition. Shall then be repeated together with that element.
NOTE 5:	Shall be present when the short number corresponds to an external number. The GTSI/ITSI element shall then be the ITSI of the corresponding gateway. Shall then be repeated together with that element.
NOTE 6:	The value of that element may correspond to the invocation of SS-TPI only when the element short number corresponds to an ITSI. (since in case of group call, SS-TPI is not invoked for the calling user but for the group).
NOTE 7:	Conditional on the value of the element SS-TPI invocation corresponding to the invocation of SS-TPI (see note 6).
NOTE 8:	Shall be present only when the value of the element overriding of SS-CAD invocation for incoming calls corresponds to such overriding for the short number being defined (since SS-CAD for incoming calls overrides SS-BIC). Shall then be repeated together with each corresponding short number element.
NOTE 9:	Shall be present only when the value of the element overriding of SS-CAD invocation for outgoing calls corresponds to such overriding for the short number being defined (since SS-CAD for outgoing calls overrides SS-BOC). Shall then be repeated together with each corresponding short number element.
NOTE 10:	Shall apply for the calls made using the SS-SNA short number to the definition of which that element applies, in case SS-CLIR would otherwise have automatically been invoked for the served user.
NOTE 11:	Such acknowledgement may be requested only together with the assignment to FE1(s) (by the element "assignment to FE1(s) requested").

The element served user identifies the individual subscriber for whom the DEFINE request/indication information flow is requesting the definition of one or more short numbers.

See subclause 5.1.1 for the meanings:

- of the elements:
 - short number;
 - new definition or deletion;
 - GTSI/ITSI;
 - external subscriber number.
- of every element related with the invocation of other supplementary services; and
- of every element related with the overriding of the invocation of other supplementary services.

The element "assignment to FE1(s) requested" indicates if the definition(s) of the short number(s) is(are) to be assigned to the FE1(s). If so, the value of the element "acknowledgement requested from FE1(s)" indicates whether or not such assignment is to be acknowledged.

NOTE 2: Thus the value of the element "assignment to FE1(s) requested" indicates whether or not one or more ASSIGN request/indication information flows will be generated as a result of the DEFINE request/indication information flow.

5.1.4 DEFINE ACK

DEFINE ACK is actually the response/confirmation information flow corresponding to the DEFINE request/indication information flow. It is thus across relationship rb from FE20 to FE3. That flow is used to inform FE3 about the completion of the corresponding definition request.

NOTE: The definition of how a given DEFINE ACK information flow relates to the corresponding DEFINE information flow is outside the scope of the stage 2 description.

Table 4 lists the elements within the DEFINE ACK information flow.

Table 4: Contents of DEFINE ACK

Element	Type
Definition result	M (note 1)
Served user	M (note 2)
Short number	O (notes 3 and 4)
SS-COLP invocation not accepted	O (note 5)
SS-TPI invocation not accepted	O (note 5)
SS-TPI invocation accepted but with no delivery of priority levels of talking/sending party speech/transmission requests	O (note 6)
SS-TPI invocation accepted but with no delivery of talking/sending party mnemonic name	O (note 6)
Overriding of SS-CAD invocation for incoming calls not accepted	O (note 5)
Overriding of SS-BIC invocation not accepted	O (note 5)
Overriding of SS-CAD invocation for outgoing calls not accepted	O (note 5)
Overriding of SS-BOC invocation not accepted	O (note 5)
NOTE 1:	There shall be only one definition result per DEFINE ACK information flow even if there is more than one served user or more than one short number.
NOTE 2:	May be repeated.
NOTE 3:	Shall be present when the definition result is: either <ul style="list-style-type: none"> - positive; or - negative for some specific short number indicated by the corresponding element.
NOTE 4:	May be repeated.
NOTE 5:	That element should be present together with the related short number when: <ul style="list-style-type: none"> - the definition result is positive; and - the corresponding request has not been accepted by the infrastructure.
NOTE 6:	That element should be present together with the related short number when: <ul style="list-style-type: none"> - the definition result is positive; - the request to invoke SS-TPI alone (i.e. without that option) as part of the related short number definition has been accepted by the infrastructure; but - not with the corresponding subscription option.

The element definition result indicates if the definition procedure, triggered by the DEFINE request/indication information flow, has been successful or not. If it has been successful, the element short number indicates which short number(s) has/have been successfully defined. See subclause 5.1.1 for the meaning of that element.

The element SS-COLP invocation not accepted shall indicate that the request that the invocation of SS-SNA using the related short number trigger that of SS-COLP has not been accepted. The same shall apply for SS-TPI with the element SS-TPI invocation not accepted, and with its options, with the two related elements (SS-TPI invocation accepted but with no delivery of priority levels of talking/sending party speech/transmission requests and SS-TPI invocation accepted but with no delivery of talking/sending party mnemonic name).

Similarly each element related to the overriding of another supplementary services not accepted shall indicate that the request that the invocation of SS-SNA using the related short number result in such supplementary service not being invoked, even if activated, has not been accepted.

5.1.5 INTERROGATE

INTERROGATE is an unconfirmed information flow across relationship rb from FE3 to FE20 which is used to interrogate the home SwMI of the served user about the current definitions of the SS-SNA short numbers for that user.

NOTE 1: The response/confirmation information flow corresponding to the INTERROGATE request/indication information flow is INTERROGATE ACK (see subclause 5.1.6).

Table 5 defines the content of the INTERROGATE information flow.

Table 5: Content of INTERROGATE

Element	Type
Served user	M
Short number	O (note)
NOTE:	May be repeated.

The element served user identifies the individual subscriber whose short number definition(s) is(are) being asked.

The element short number (see subclause 5.1.1 for its meaning) may be present to limit the scope of the interrogation to one or more specific short numbers.

NOTE 2: Contrary to the specification of the DEFINE request/indication information flow, the element served user is not repeated in the INTERROGATE request/indication information flow.

5.1.6 INTERROGATE ACK

INTERROGATE ACK is actually the response/confirmation information flow corresponding to the INTERROGATE request/indication information flow. It is thus across relationship rb from FE20 to FE3. It is used to respond to the corresponding interrogation request.

NOTE: The definition of how a given INTERROGATE ACK information flow relates to the corresponding INTERROGATE information flow is outside the scope of the stage 2 description.

Table 6 lists the elements within the INTERROGATE ACK information flow.

Table 6: INTERROGATE ACK contents

Element	Type
Interrogation result	M (note 1)
Served user	M
Short number	O (notes 2 and 3)
Short number defined/not defined	C (note 4)
GTSI/ITSI	C (notes 2 and 5)
External subscriber number	C (note 6)
SS-COLP invocation	C (note 5)
SS-TPI invocation	C (notes 5 and 7)
Delivery of priority levels of talking/sending party speech/transmission requests	C (note 8)
Delivery of talking/sending party mnemonic name	C (note 8)
Overriding of SS-CAD invocation for incoming calls	C (note 5)
Overriding of SS-BIC invocation	C (note 9)
Overriding of SS-CAD invocation for outgoing calls	C (note 5)
Overriding of SS-BOC invocation	C (note 10)
Overriding of SS-CLIR invocation	C (notes 5 and 11)
Assignment to FE1 requested	O (note 12)
Acknowledgement requested from FE1	O (note 13)
NOTE 1:	There shall be only one interrogation result even if there are more than one short number.
NOTE 2:	Shall be present when the interrogation result is positive or when it is negative for the some specific short number indicated by the corresponding element.
NOTE 3:	Should be repeated for each different short number if the interrogation is about all short numbers or for only those included in the interrogation request. Otherwise, there shall be as many INTERROGATE ACK request/indication information flows as there are different short numbers for which a response can be given.
NOTE 4:	Shall be repeated as many times as the element short number.
NOTE 5:	Shall be present when the value of the element short number defined/not defined indicates that the short number to which it applies has been defined. Shall then be repeated together with that element.
NOTE 6:	Shall be present when the short number corresponds to an external number. The GTSI/ITSI element shall then be the ITSI of the corresponding gateway. Shall then be repeated together with that element.
NOTE 7:	The value of that element may correspond to the invocation of SS-TPI only when the element short number corresponds to an ITSI. (since in case of group call, SS-TPI is not invoked for the calling user but for the group).
NOTE 8:	Conditional on the value of the element SS-TPI invocation corresponding to the invocation of SS-TPI (see note 7).
NOTE 9:	Shall be present only when the value of the element overriding of SS-CAD invocation for incoming calls corresponds to such overriding for the short number being defined (since SS-CAD for incoming calls overrides SS-BIC). Shall then be repeated together with each corresponding short number element.
NOTE 10:	Shall be present only when the value of the element overriding of SS-CAD invocation for outgoing calls corresponds to such overriding for the short number being defined (since SS-CAD for outgoing calls overrides SS-BOC). Shall then be repeated together with each corresponding short number element.
NOTE 11:	Shall apply for the calls made using the SS-SNA short number to the definition of which that element applies, in case SS-CLIR would otherwise have automatically been invoked for the served user.
NOTE 12:	Optional, subject to the interrogation result being positive.
NOTE 13:	Such acknowledgement may have been requested only together with the assignment to FE1 (by the element "assignment to FE1 requested").

NOTE: When the definition request of a short number has failed, the result of the interrogation about the definition of that short number is: either

- that which existed before, if there was one; or
- none.

The element served user indicates the identity of the individual user for which the response to previous interrogation is being given in the INTERROGATE ACK information flow.

The element interrogation result indicates if the interrogation procedure triggered by the INTERROGATE information flow request/indication has been successful or not. If it has been successful, the element short number (see subclause 5.1.1 for its meaning) indicates the short number to which the next element, short number defined/not defined, applies. That element indicates whether a definition of that short number exists or none. If such definition exists, the element GTSI/ITSI shall then give it, together with:

- possibly the element external subscriber number;
- every element related with the invocation of other supplementary services; and
- every element related with the overriding of the invocation of other supplementary services.

See subclause 5.1.1 for the meanings of the above elements.

The element assignment to FE1 requested indicates that the short number definition has been requested to be sent to the served user for his information. If yes, the element acknowledgement requested from FE1 indicates if the FE1 (i.e. in the served user MS/LS) has been requested to acknowledge the reception of the information.

5.1.7 INVOKE

INVOKE is an unconfirmed information flow across relationship ra from FE1 to FE21 to invoke SS-SNA.

Table 7 defines the content of the INVOKE information flow.

Table 7: Content of INVOKE

Element	Type
Short number	M

See subclause 5.1.1 for the meaning of the element short number.

5.1.8 INVOCATION FAILURE

INVOCATION FAILURE is an unconfirmed information flow across relationship ra from FE21 to FE1 to inform the calling user who has invoked SS-SNA using a short number that that invocation has failed.

Element	Type
Failure cause	M

The element failure cause indicates why SS-SNA failed. Those causes may be that:

- the supplementary service has not been subscribed for that user; or
- the SS-SNA short number is not defined (in FE21).

- NOTE 1: The above statement implies that there is a FE21 functional entity. Otherwise by definition there is no information flow INVOCATION FAILURE (since the originating SwMI does not support SS-SNA). In such a case, the calling user who has invoked SS-SNA will be informed about the invocation failure by the disconnect cause: SS-SNA not supported, sent by the originating SwMI when clearing his call attempt.
- NOTE 2: When the definition of the identity corresponding to the invoked SS-SNA short number contradicts the basic service requested in the SETUP request/indication information flow (i.e. that definition corresponds to an ITSI while the basic service communication type is point-to-multipoint, point-to-multipoint acknowledged or broadcast, or it corresponds to a GTSI while the basic service communication type is point-to-point), it will be up to the group/called user home SwMI to decide whether it continues the call establishment in modifying the basic service communication type requested or if clears the call attempt. The case where the group/called user home SwMI clears the call attempt is not considered as a SS-SNA invocation failure.
- NOTE 3: The case where the definition of the short number includes the control of other supplementary service invocations and where the originating SwMI does not support one or more of those supplementary services (or their subscription options) does not result in a SS-SNA invocation failure. Moreover, the calling user should be informed about such non-support by the SS SUPPORT INFO request/indication information flow.

5.1.9 SS SUPPORT INFO

SS SUPPORT INFO is an unconfirmed information flow across relationship ra from FE21 to FE1 which informs the served user that the originating SwMI (to which FE21 is always allocated - see table 10):

- does not support supplementary services or their subscription options which would be invoked if the served user invokes SS-SNA using some short number; or
- will not accept to override the invocations of SS-BOC or of SS-CAD for outgoing calls while such overriding would be requested if the served user invokes SS-SNA using some short number.

Table 8 lists the elements within the SS SUPPORT INFO information flow.

Table 8: Contents of SS SUPPORT INFO

Element	Type (note 1)
SS-COLP not supported	O
SS-TPI not supported	O
SS-TPI supported but with no delivery of priority levels of talking/sending party speech/transmission requests	O (note 2)
SS-TPI supported but with no delivery of talking/sending party mnemonic name	O (note 2)
Overriding of SS-CAD invocation for outgoing calls not accepted	O
Overriding of SS-BOC invocation not accepted	O
NOTE 1: At least one element shall be included in the SS SUPPORT INFO request/indication information flow.	
NOTE 2: That element may only be present when the element SS-TPI not supported is not.	

The elements within SS SUPPORT INFO indicate when SS-COLP or SS-TPI are not supported by the served user SwMI, else when SS-TPI is supported by that SwMI but not the subscription options of delivery of the priority levels of talking/sending party speech/transmission requests and/or of the talking/sending party mnemonic name.

- NOTE: Like ASSIGN, the SS SUPPORT INFO request/indication information flow will generally be addressed individually to FE1 (i.e. in the served user MS/LS). However in the specific case where the same information is to be delivered to all members of a group, the SS SUPPORT INFO request/indication information flow may be broadcast to that group.

5.1.10 Information flow elements

The definitions of most of the element contents of the information flows has been presented together with those information flows (in subclauses 5.1.1 to 5.1.9). For the definitions of the elements missing, see those of the PDU information elements with the same names, in subclause 5.2.2 of ETS 300 392-12-7 [7], on SS-SNA stage 3 description.

5.2 Relationship of information flows to basic call information flows

The INVOKE request/indication information flow shall be sent in conjunction with the basic call set-up request/indication information flow or with the short data service request/indication information flow.

All other SS-SNA information flows shall be call unrelated.

Table 9 further develops the relationship of the SS-SNA information flows to those of basic call over the air interface.

NOTE: There is no relationship of the SS-SNA information flows to those of basic call over the intersystem interface (ISI).

Table 9: Relationship of SS-SNA information flows to basic call

Information flow	Independent of basic call?	With basic call?	Basic call flows:
ASSIGN	yes	no	
ASSIGN ACK	yes	no	
DEFINE	yes	no	
DEFINE ACK	yes	no	
INTERROGATE	yes	no	
INTERROGATE ACK	yes	no	
INVOKE	no	yes	Air interface SETUP request/indication (note 1)
INVOCATION FAILURE	no	yes	Air interface RELEASE request/indication (note 2)
SS SUPPORT INFO	yes	no	
NOTE 1: INVOKE shall be sent across relationship ra together with the air interface SETUP request/indication information flow whether for a group call or for an individual call.			
NOTE 2: INVOCATION FAILURE shall be sent across relationship ra together with the air interface RELEASE request/indication information flow whether for a group call or for an individual call.			

5.3 Service primitives

This clause lists SS-SNA service primitives used to invoke or being a result of information flow sequences. The SS-SNA service primitives are defined in ETS 300 392-12-7 [7], subclause 5.4 and the basic call service primitives are defined in ETS 300 392-2 [3], clause 11.

The SS-SNA service primitives for the served user at the MS/LS TNSS-SAP shall be:

- ASSIGN indication;
- INVOKE request;
- INVOCATION FAILURE indication;
- SS SUPPORT INFO indication.

The SS-SNA service primitives for the authorized user at the MS/LS TNSS-SAP shall be:

- DEFINE request;
- DEFINE ACK indication;
- INTERROGATE request;
- INTERROGATE ACK indication.

5.4 Examples of information flow sequences

ETS 300 392-12-7 [7], on SS-SNA stage 3 description, specifies the signalling procedures in support of the information flow sequences specified in the following subclauses. In addition, it specifies signalling procedures to cover other sequences arising from error situations, interactions with basic call, interactions with other supplementary services, different topologies etc.

In the figures, SS-SNA information flows are represented by solid arrows and basic call information flows are represented by broken arrows. An ellipse embracing two information flows indicates that the two information flows occur together. Within a column representing an SS-SNA functional entity, the numbers refer to functional entity actions listed in clause 6.

5.4.1 Definition

5.4.1.1 Definition with no assignment

Figure 4 shows the information flow sequence for the normal operation of SS-SNA definition in the case where no assignment to served user(s) has been requested.

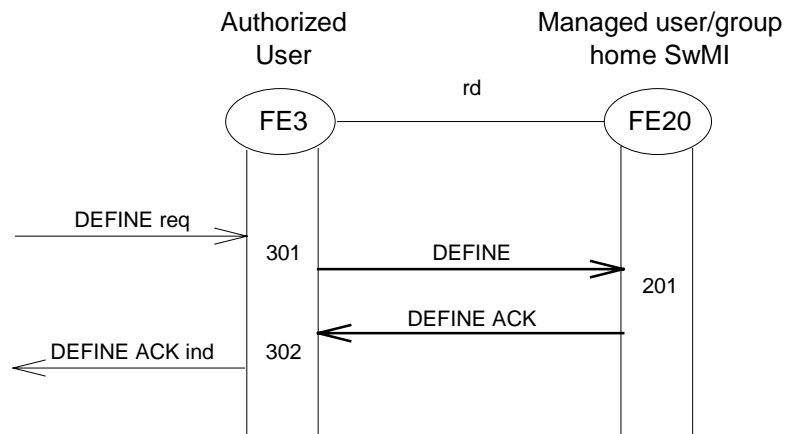
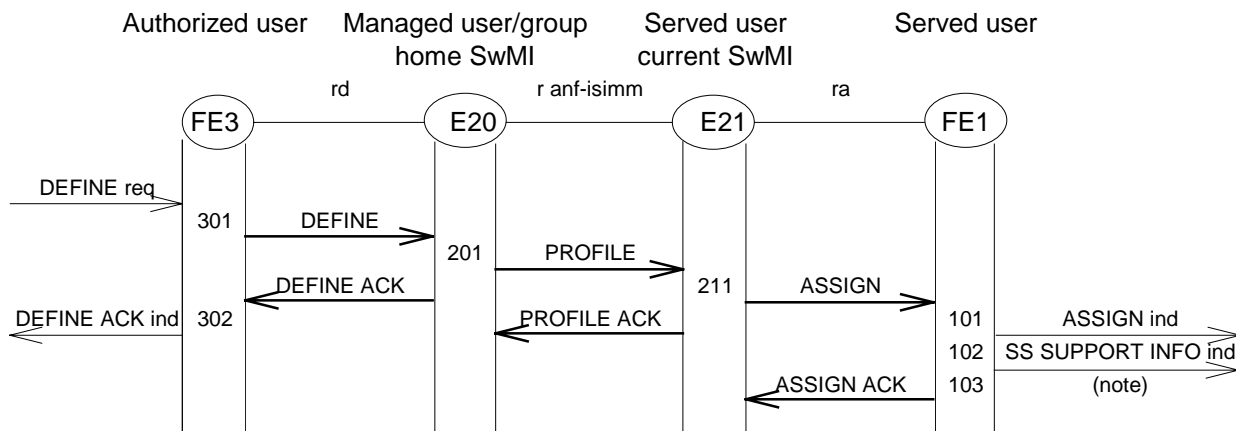

Figure 4: Definition of SS-SNA with no assignment to served user(s)

NOTE: The SS-SNA definition is then passed by FE20 to F21 by the ANF-ISIMM SS-PROFILE information flow (see clause 8).

5.4.1.2 Definition with assignment in visited SwMI

Figure 5 shows the information flow sequence for the normal operation of SS-SNA definition in the case where its assignment to served user(s) has been requested and when that user has migrated.



NOTE: The primitive SS SUPPORT INFO indication shall only be present if the element limitations on other supplementary service invocations/ invocation overriding is.

Figure 5: Definition of SS-SNA with assignment to served user(s)

5.4.1.3 Definition including control of supplementary services rejected by visited SwMI

Figure 6 shows the information flow sequence for informing the served user(s) in his(their) visited SwMI when a new SS-SNA short number is defined and that definition controls:

- the invocations of supplementary services which are not supported by the visited SwMI; and/or
- the overriding of supplementary services which are rejected by the visited SwMI.

The same information flow sequence will also occur when the served user migrates into a new SwMI (unless the related information is sent in the ASSIGN information flow).

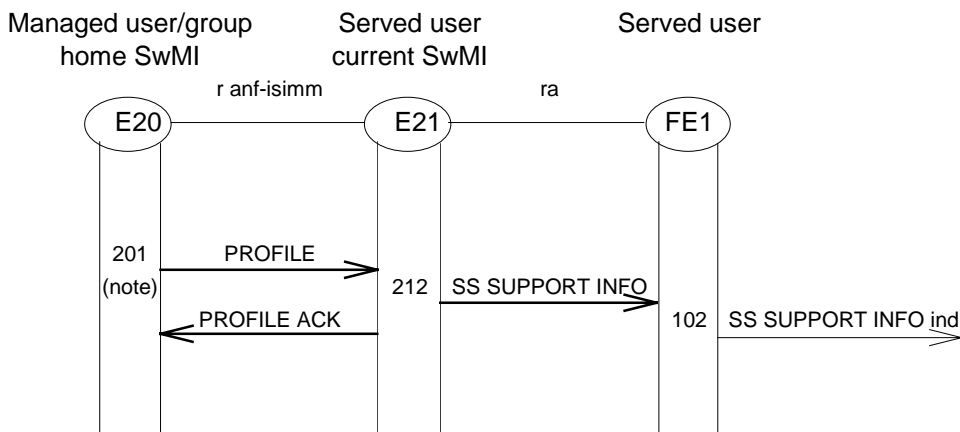

NOTE: Actually the action for sending the profile information flows is not a SS-SNA action.

Figure 6: Delivery of information about supplementary services not supported to served user(s)

5.4.2 Interrogation

Figure 7 shows the information flow sequence for the normal operation of SS-SNA interrogation.

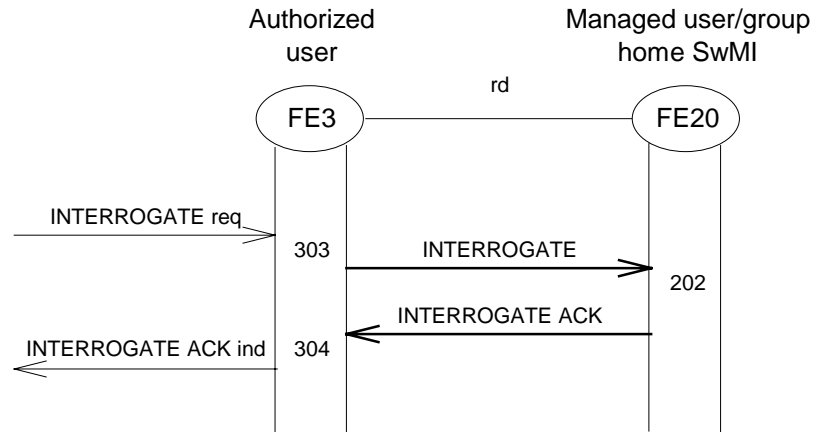

Figure 7: Interrogation of SS-SNA

5.4.3 Invocation and operation

5.4.3.1 Basic invocation and operation with successful call establishment

Figure 8 shows the information flow sequence for the successful SS-SNA invocation and operation at set-up time for either a group call or an individual call.

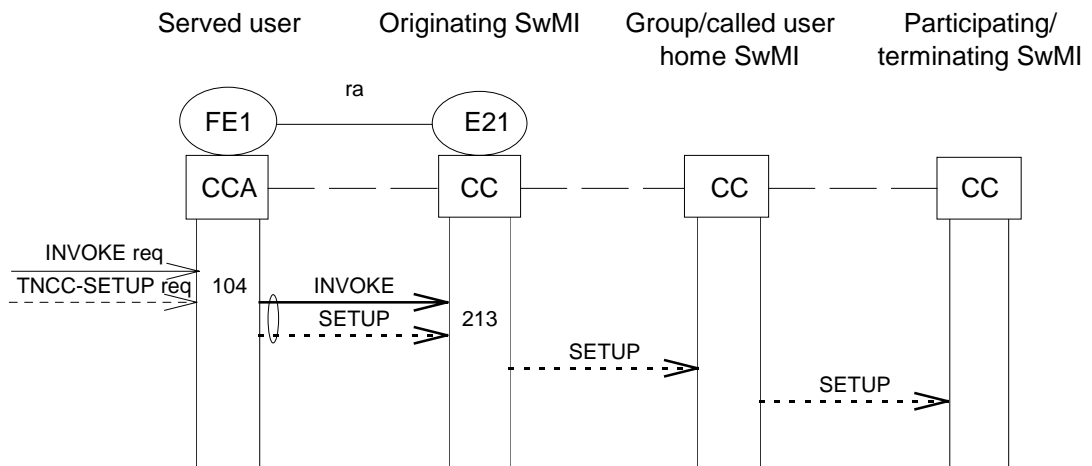

Figure 8: Basic invocation and operation of SS-SNA over ISI - successful call establishment

5.4.3.2 SS-SNA invocation failure

Figure 9 shows the information flow sequence when SS-SNA invocation fails because either SS-SNA has not been subscribed for the calling user or there is no ITSI or GTSI defined for the short number sent by the calling user in his SS-SNA invocation.

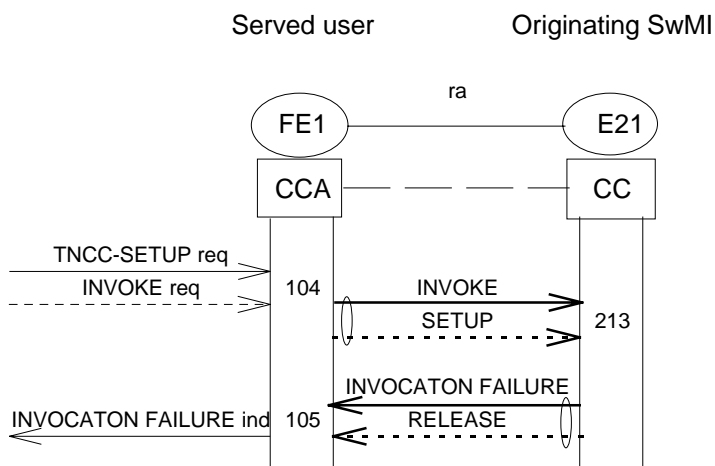

Figure 9: Failure of SS-SNA invocation

6 FE actions

These functional entity actions cover items presented in the previous scenarios. There may be other actions due to exceptional cases.

6.1 Functional Entity actions of FE1

- 101 Receive the short number definition(s) and deliver it/them to the user application.
- 102 Relay to the user application the SS-SNA information received about supplementary services the invocations of which are controlled by SS-SNA and which are not supported.
- 103 Acknowledge the SS-SNA definition assignment, if acknowledgement was requested.
- 104 Relay the SS-SNA invocation received from the user application.
- 105 Relay the received INVOCATION FAILURE information flow to the user application.

6.2 Functional Entity actions of FE20

- 201 On receipt of DEFINE request/indication information flow, verify that:
- the request is authorized (for the authorized user to make definitions for the served user(s));
 - SS-SNA has been subscribed to for the served user; and
 - the parameters in the request are valid.
- If the request is valid, make the SS-SNA definition to the SwMI and send the DEFINE ACK information flow to FE3. If the request is not valid or authorized, return an error indication to FE3. The case where the definition request includes the invocation of another supplementary service which is not accepted (e.g. because it is not supported) shall not be considered as a definition failure case: the definition request shall be changed accordingly by FE20. FE20 shall indicate the corresponding change when acknowledging that request. The same shall hold if the definition request includes:
- the invocation overriding of SS-CAD for outgoing calls and/or that of SS-BOC and such overriding are not accepted by FE20;
 - the invocation overriding of SS-CAD for incoming calls and/or that of SS-BIC and such overriding are not accepted by FE20 or by the FE20 functional entities for those supplementary services;
 - the invocation of SS-TPI with some subscription option(s) and that invocation is not accepted.
- NOTE: If the served user has migrated, ANF-ISIMM will then ensure the sending of that definition to FE21 (i.e. in the served user SwMI) by sending the corresponding profile information. In addition, whenever the served user migrates after that definition has been made, ANF-ISIMM will also then ensure the sending of that definition by the same profile sending.

- 202 On receipt of INTERROGATE request/indication information flow, verify that:
- the request is authorized (for the authorized user to place interrogations on SS-SNA definitions for the served user);
 - SS-SNA has been subscribed to for the served user; and
 - the parameters in the request are valid.
- If the request is valid, fetch the SS-SNA data and send it in the INTERROGATE ACK information flow to FE3. If the request is not valid or authorized, return an error indication to FE3.

6.3 Functional Entity actions of FE21

- 211 If the authorized user requested it, send the short number definition(s) to the served user(s) - for his (their) information - in the ASSIGN request/indication information flow, in indicating in that information flow any limitations to those definitions regarding the control of other supplementary services by the specific FE21 (i.e. only in case of migration of the served user). Receive the corresponding acknowledgement if sent by FE1.
- 212 On receipt of the information flows of the ANF-ISIMM migration service informing the served user SwMI about the SS-SNA short numbers defined for the served (and migrating user), send the SS SUPPORT INFO request/indication information flow to FE1 if at least one of the following conditions applies:
- the definitions of one or more of those short numbers include the invocation of SS-COLP and the served user SwMI does not support SS-COLP such supplementary;
 - the definitions of one or more of those short numbers include the invocation of SS-TPI and the served user SwMI does not support SS-TPI;
 - the definitions of one or more of those short numbers include the invocation of SS-TPI with a SS-TPI subscription option (e.g. delivery of talking/sending party mnemonic name) and the served user SwMI supports SS-TPI but not that option;
 - the definitions of one or more of those short numbers include the overriding of SS-CAD invocation for outgoing calls and the served user SwMI does not accept such overriding;
 - the definitions of one or more of those short numbers include the overriding of SS-BOC invocation and the served user SwMI does not accept such overriding.

213 On receipt of the call request with the INVOKE request/indication information flow from FE1, check if SS-SNA has been activated (i.e. subscribed to). If yes, verify the invoked short number and fetch the corresponding GTSI or ITSI, possibly together with the accompanying instructions:

- to invoke SS-COLP and/or SS-TPI (for an individual call only); and/or
- to override the possible invocations of:
 - SS-CAD for outgoing calls or SS-BOC; and/or
 - SS-CLIR; and/or
 - SS-CAD for incoming calls or SS-BIC.

NOTE: The overriding of SS-CAD for incoming calls or SS-BIC results in specific SS-CAD or SS-BIC information flows.

If SS-SNA has not been activated (i.e. subscribed to) or if no definition corresponding to the invoked short number exists, abort SS-SNA invocation and inform the calling user about that, using the INVOCATION FAILURE request/indication information flow.

6.4 Functional Entity actions of FE3

301 Detect the user application request for making a SS-SNA definition and send to FE20 the corresponding DEFINE request/indication information flow.

302 Deliver to the user application the information received in DEFINE ACK.

303 Detect the user application request for interrogation and send to FE20 the corresponding INTERROGATE request/indication information flow.

304 Deliver to the user application the information received in INTERROGATE ACK.

7 Allocation of functional entities to physical equipment

There is only one possible scenario for the allocation of functional entities to SwMIs and MS/LSs in the case of group call or individual call: FE1 collocated with the calling MS/LS, FE21, with the served user SwMI, which is then the originating SwMI for the call (see table 10).

The possible scenarios for the allocation of functional of functional entities to SwMIs and MS/LSs for the management of SS-SNA are shown in table 11.

Table 10: Scenario for the allocation of FEs to physical equipment/SwMIs in the case of group or individual call

	FE1	FE21
Scenario 1	Calling user MS/LS	Originating SwMI

Table 11: Scenarios for the allocation of FEs to physical equipment/SwMIs in the case of management

	FE3	FE20	FE21	FE1
Scenario 1	Authorized user MS/LS (notes 1 and 2)	Served user home SwMI (note 3)	Served user SwMI	Served user MS/LS
Scenario 2	Served user home SwMI (note 4)	Served user home SwMI	Served user SwMI	Served user MS/LS
NOTE 1:	The served user may have a limited capability of authorized user to interrogate his home SwMI about his own short number definitions.			
NOTE 2:	When defining short numbers which trigger the invocation of SS-COLP or SS-TPI, or the overriding of SS-BOC invocation or of SS-CAD invocation for outgoing calls, the authorized user should also be the authorized user for those supplementary services.			
NOTE 3:	When defining short numbers which trigger the overriding of SS-BIC invocation or of SS-CAD invocation for incoming calls, the served user home SwMI should have collocated with it an authorized user functional entity for those supplementary services.			
NOTE 4:	This scenario is outside the scope of SS-SNA standardization.			

NOTE: The possibility of FE20 being allocated to the SwMI where the served user is currently registered has been ruled out. This means that when an FE3 functional entity limited to the definition of SS-SNA short numbers is allocated to the MS/LS of the served user, the definition requests from that user will be addressed to his home SwMI (who will then invoke ANF-ISIMM to download them to the served user SwMI).

8 Interworking considerations

The case where SS-SNA extends to several TETRA networks has already been taken into account in the preceding clauses, except for the exchange of information related to the support and the subscription of SS-SNA with the related supplementary service profile information. Such exchange occurs when:

- a subscriber migrates into a SwMI different from his home SwMI; or
- definition modifications (either new definitions or definition changes) are made while the SwMI where the served user is registered is different from his home SwMI.

As defined in ETS 300 392-3-5 [4], such exchange is ensured:

- in the first case (i.e. when the subscriber migrates into a SwMI different from his home SwMI): by
 - the PROFILE UPDATE request/indication information flow, which contains the information whether SS-SNA has been subscribed to for the subscriber (which implies that SS-SNA is supported by the concerned MS). If so, the corresponding PROFILE UPDATE response/confirmation information flow contains the information whether SS-SNA is supported by the visited SwMI; followed by
 - the SS-PROFILE UPDATE request/indication information flows, containing the SS-SNA profile, and the corresponding response/confirmation.
- in the second case, subject to SS-SNA being subscribed to for the subscriber and supported by his visited SwMI, only by the SS-PROFILE UPDATE request/indication information flows, containing the SS-SNA profile, and the corresponding response/confirmation.

More precisely, the information about the SS-SNA subscription is carried by the sub-element SS-information in the element individual basic migration profile in the PROFILE UPDATE request/indication information flow, while the response about the SS-SNA support by the visited SwMI is carried by the sub-element SS-information response in the element individual basic migration profile in the PROFILE UPDATE response/confirmation information flow.

Normally, when SS-SNA has been subscribed to for a subscriber, his home SwMI shall download:

- all the corresponding SS-SNA definitions to the visited SwMI when that subscriber (i.e. the served user) migrates in that SwMI;
- every SS-SNA definition modification made while that subscriber remains in that (same) SwMI.

The sub-sub-element SS status of the above mentioned sub-element SS-information shall then take the value corresponding to SS-SNA subscribed to with SS-migration profile. If the served user invokes SS-SNA using a short number the definition of which has not yet been downloaded in his visited (served user) SwMI, this shall result in an invocation failure.

The downloading of a SS-SNA profile by the home SwMI to the visited SwMI shall be done using the sub-element SS-migration profile (original) in the SS-PROFILE UPDATE request/indication information flow. Table 12 defines the SS-SNA information which shall then be included in the sub-sub-element SS-ISI-PROFILE (original) of that sub-element SS-migration profile (original).

Table 12: SS-SNA information in SS-ISI-PROFILE (original)

Sub-element	Type
Short number	M (note 1)
New definition or deletion	M (note 2)
GTSI/ITSI	M (note 3)
External subscriber number	O (note 4)
SS-COLP invocation	O (note 3)
SS-TPI invocation	O (notes 3 and 5)
Delivery of priority levels of talking/sending party speech/transmission requests	O (note 6)
Delivery of talking/sending party mnemonic name	O (note 6)
Overriding of SS-CAD invocation for incoming calls	O (note 3)
Overriding of SS-BIC invocation	O (note 7)
Overriding of SS-CAD invocation for outgoing calls	O (note 3)
Overriding of SS-BOC invocation	O (note 8)
Overriding of SS-CLIR invocation	O (notes 3 and 9)
Assignment to FE1 requested	O
Acknowledgement requested from FE1	C (note 10)
NOTE 1: Shall be repeated for each different short number defined.	
NOTE 2: Shall be repeated as many times as the element short number.	
NOTE 3: Shall be present when the value of the element new definition or deletion corresponds to new definition. Shall then be repeated together with that element.	
NOTE 4: Shall be present when the short number corresponds to an external number. The GTSI/ITSI element shall then be the ITSI of the corresponding gateway. Shall then be repeated together with that element.	
NOTE 5: The value of that element may correspond to the invocation of SS-TPI only when the element short number corresponds to an ITSI. (since in case of group call, SS-TPI is not invoked for the calling user but for the group).	
NOTE 6: Conditional on the value of the element SS-TPI invocation corresponding to the invocation of SS-TPI (see note 6).	
NOTE 7: Shall be present only when the value of the element overriding of SS-CAD invocation for incoming calls corresponds to such overriding for the short number being defined (since SS-CAD for incoming calls overrides SS-BIC). Shall then be repeated together with each corresponding short number element.	
NOTE 8: Shall be present only when the value of the element overriding of SS-CAD invocation for outgoing calls corresponds to such overriding for the short number being defined (since SS-CAD for outgoing calls overrides SS-BOC). Shall then be repeated together with each corresponding short number element.	
NOTE 9: Shall apply for the calls made using the SS-SNA short number to the definition of which that element applies, in case SS-CLIR would otherwise have automatically been invoked for the served user.	
NOTE 10: Such acknowledgement may have been requested only together with the assignment to FE1 (by the element "assignment to FE1 requested").	

See subclause 5.1.1 for the meanings:

- of the elements:
 - short number;
 - GTSI/ITSI;
 - external subscriber number.
- of every element related to the invocation of other supplementary services;
- of every element related to the overriding of the invocation of other supplementary services; and
- of the element acknowledgement requested from FE1.

See subclause 5.1.3 for the meaning of the element assignment to FE1 requested.

If they are part of the definition of one or more short numbers for the served user, the elements related to the invocation of other supplementary services or to the overriding of the invocation of other supplementary services shall be included in the SS-SNA information in SS-ISI-PROFILE (original), even if the served user SwMI does not support the corresponding supplementary services.

NOTE: The reason for including those elements even when the corresponding supplementary services are not supported is that otherwise a new assignment would be needed for the same short number(s) when the served user migrates into another SwMI which supports those supplementary services.

SS-SNA short numbers may be used for calling external parties. The corresponding definitions and profiles shall then indicate both:

- the numbers of those external parties; and
- the identities (ITSIs) of the corresponding gateways. Each such gateway may be defined by the authorized user to be a gateway in the visited SwMI or in the home SwMI of the served user.

History

Document history			
May 1999	Public Enquiry	PE 9940:	1999-05-05 to 1999-10-01
February 2000	Vote	V 200014:	2000-02-07 to 2000-04-07