

**E**UROPEAN  
**T**ELECOMMUNICATION  
**S**TANDARD

**FINAL DRAFT**  
pr **ETS 300 392-11-6**

August 1998

---

Source: TETRA

Reference: DE/TETRA-03001-11-06

ICS: 33.020

**Key words:** TETRA, V+D

**Terrestrial Trunked Radio (TETRA);  
Voice plus Data (V+D);  
Part 11: Supplementary services stage 2;  
Sub-part 6: Call Authorized by Dispatcher (CAD)**

**ETSI**

European Telecommunications Standards Institute

**ETSI Secretariat**

**Postal address:** F-06921 Sophia Antipolis CEDEX - FRANCE

**Office address:** 650 Route des Lucioles - Sophia Antipolis - Valbonne - FRANCE

**Internet:** secretariat@etsi.fr - <http://www.etsi.fr> - <http://www.etsi.org>

Tel.: +33 4 92 94 42 00 - Fax: +33 4 93 65 47 16

---

**Copyright Notification:** No part may be reproduced except as authorized by written permission. The copyright and the foregoing restriction extend to reproduction in all media.

© European Telecommunications Standards Institute 1998. All rights reserved.



## Contents

Foreword.....		5
1	Scope .....	7
2	Normative references .....	7
3	Definitions and abbreviations .....	8
3.1	Definitions .....	8
3.2	Abbreviations .....	8
4	Functional model .....	8
4.1	Functional model description .....	8
4.2	Description of FEs .....	10
4.2.1	Calling/restricted user A's functional entity, FE1 .....	10
4.2.2	CAD control functional entity, FE2 .....	10
4.2.3	Authorized user's functional entity, FE3 .....	11
4.2.4	Dispatcher user's functional entity, FE7 .....	11
4.2.5	Relationship of functional model to basic call functional model .....	11
5	Information flows .....	11
5.1	Definition of information flows .....	11
5.1.1	ACCEPT .....	11
5.1.2	ACCEPTED .....	12
5.1.3	ACTIVATE .....	12
5.1.4	ACTIVATE ACK .....	12
5.1.5	CANCEL .....	12
5.1.6	DEACTIVATE .....	13
5.1.7	DEACTIVATE ACK .....	13
5.1.8	DEFINE .....	13
5.1.9	DEFINE ACK .....	14
5.1.10	DIVERT .....	14
5.1.11	DIVERTED .....	15
5.1.12	INTERCEPTED .....	15
5.1.13	INTERROGATE .....	15
5.1.14	INTERROGATE ACK .....	16
5.1.15	REJECT .....	16
5.1.16	REJECTED .....	16
5.1.17	REQUEST .....	17
5.2	Relationship of information flows to basic call information flows .....	18
5.3	Service primitives .....	18
5.4	Information flow sequences .....	19
5.4.1	Normal operation .....	19
5.4.2	Successful interception without call set-up to dispatcher in home SwMI .....	20
5.4.3	Successful interception with "on-demand" call set-up to the dispatcher .....	20
5.4.4	Successful interception with Direct call set-up to the dispatcher .....	21
5.4.5	Rejection of call without call set-up to the dispatcher .....	21
5.4.6	Rejection of call after call set-up to the dispatcher .....	22
5.4.7	Calling user A disconnects the call during interception .....	22
5.4.8	Calling user A disconnects when connection is established to the dispatcher .....	23
5.4.9	User A in home SwMI, authorization in user A home SwMI with the dispatcher migrated into another SwMI .....	23
5.4.10	Authorization in home SwMI against user B when user A has migrated into another SwMI .....	24
5.4.11	Authorization in visited SwMI against user A when user A has migrated into that SwMI .....	24

5.4.12	Authorization in home SwMI when user A and the dispatcher has migrated into different SwMIs .....	25
5.4.13	Authorization in user B home SwMI against user B when user A and the dispatcher has migrated into the same SwMI.....	26
5.4.14	User A in home SwMI , authorization in another SwMI against user B of the other SwMI .....	27
5.4.15	Call completion .....	27
5.4.16	Activation/deactivation information flow .....	28
5.4.17	Definition information flow.....	29
5.4.18	Interrogation information flow .....	29
5.4.19	Exceptional operation .....	30
5.5	FE actions .....	30
5.5.1	FE actions of FE1 .....	30
5.5.2	FE actions of FE2 .....	30
5.5.3	ISI FE actions of FE2.....	32
5.5.4	FE actions of FE3 .....	32
5.5.5	FE actions of FE7 .....	32
6	Allocation of FEs to physical equipment .....	33
7	Inter-working considerations.....	33
7.1	Operation.....	33
7.2	Management .....	34
7.3	Migration.....	34
	History .....	35

## Foreword

This final draft European Telecommunication Standard (ETS) has been produced by the Terrestrial Trunked Radio (TETRA) Project of the European Telecommunications Standards Institute (ETSI), and is now submitted for the Voting phase of the ETSI standards approval procedure.

This ETS consists of 14 parts as follows:

This ETS is a multi-part standard and will consist of the following parts:

- Part 1: "General network design".
- Part 2: "Air Interface (AI)".
- Part 3: "Inter-System Inter-working (ISI)".
- Part 4: "Gateways".
- Part 5: "Peripheral Equipment Interface (PEI)".
- Part 6: "Line connected Station (LS)", (DE/TETRA-03001-6).
- Part 7: "Security".
- Part 9: "General requirements for supplementary services".
- Part 10: "Supplementary services stage 1".
- Part 11: "Supplementary services stage 2".**
- Part 12: "Supplementary services stage 3".
- Part 13: "SDL model of the Air Interface (AI)".
- Part 14: "Protocol Implementation Conformance Statement (PICS) proforma specification".

<b>Proposed transposition dates</b>	
Date of latest announcement of this ETS (doa):	3 months after ETSI publication
Date of latest publication of new National Standard or endorsement of this ETS (dop/e):	6 months after doa
Date of withdrawal of any conflicting National Standard (dow):	6 months after doa

Blank page

## 1 Scope

This ETS defines the stage 2 specifications of the Supplementary Service Call Authorized by Dispatcher (SS-CAD) for the Terrestrial Trunked Radio (TETRA) as provided by European operators. Stage 2 identifies the functional entities involved in the supplementary service and the information flows between them. Stage 2 is part of three stage definition where stage 1 (ETS 300 392-10-06 [1]) specifies the service description and the procedures of the supplementary service and stage 3 specifies the service primitives, PDUs and protocols for functional entities.

NOTE: The stage 2 description is followed by the stage 3 description ETS 300 392-12-6 [2], which specifies the encoding rules for the information flows and process behaviour for the different entities in the SwMI, in the MS and in the LS.

Aspects relating to all supplementary services are detailed in ETS 300 392-9 [7].

Man-Machine Interface (MMI) and charging principles are outside the scope of this ETS.

The SS-CAD ensures that predefined TETRA calls do not proceed without first being authorized by a dispatcher.

## 2 Normative references

This ETS incorporates, by dated or undated reference, provisions from other publications. These normative references are cited at the appropriate places in the text and the publications are listed hereafter. For dated references, subsequent amendments to, or revisions of, any of these publications apply to this ETS only when incorporated in it by amendment or revision. For undated references the latest edition of the publication referred to applies.

- [1] prETS 300 392-10-06: "Terrestrial Trunked Radio (TETRA); Voice plus Data (V+D); Part 10: Supplementary Services (SS) stage 1; Sub-part 6: Call Authorized by Dispatcher (CAD)".
- [2] prETS 300 392-12-06: "Terrestrial Trunked Radio (TETRA); Voice plus Data (V+D); Part 12: Supplementary Services (SS) stage 3; Sub-part 6: Call Authorized by Dispatcher (CAD)".
- [3] ETS 300 392-2: "Radio Equipment and Systems (RES); Trans-European Trunked Radio (TETRA); Voice plus Data (V+D); Part 2: Air Interface (AI)".
- [4] prETS 300 392-3-1: "Terrestrial Trunked Radio (TETRA); Voice plus Data (V+D); Part 3: Inter-System Inter-working (ISI); Sub-part 1: General description".
- [5] prETS 300 392-3-2: "Terrestrial Trunked Radio (TETRA); Voice plus Data (V+D); Part 3: Inter-System Inter-working (ISI); Sub-part 2: Additional Network Functions Individual Call (ANF-ISIIC)".
- [6] prETS 300 392-3-5: "Terrestrial Trunked Radio (TETRA); Voice plus Data (V+D); Part 3: Inter-System Inter-working (ISI); Sub-part 5: Additional Network Functions Mobility Management (ANF-ISIMM)".
- [7] prETS 300 392-9: "Terrestrial Trunked Radio (TETRA); Voice plus Data (V+D); General requirements for Supplementary Services (SS)".

### 3 Definitions and abbreviations

#### 3.1 Definitions

For the purposes of this ETS, in addition to the definitions defined in ETS 300 392-2 [3], the following definitions apply:

**authorized user:** The user who can make service definition. The authorized user can also activate/deactivate and interrogate the service.

**dispatcher:** The user to whom the request for authorization is directed.

**restricted user:** The user who's calls are forced to be authorized by a dispatcher before the call can proceed. The restricted user can be either the calling user A or the called user B or both.

#### 3.2 Abbreviations

For the purposes of this ETS, the following abbreviations apply:

CCA	Call Control Agent
FE	Functional Entity
MMI	Man Machine Interface
ITSI	Individual TETRA Subscriber Identity
PDU	Protocol Data Unit
M	Mandatory
O	Optional
CAD	Call Authorized by Dispatcher
SS	Supplementary Service

NOTE: The abbreviation SS is only used when referring to a specific supplementary service.

SwMI                      Switching and Management Infrastructure

### 4 Functional model

#### 4.1 Functional model description

The functional model for SS-CAD shall, for each normal call set-up, consider the SS-CAD conditions defined in the subscriber data for both user A and user B respectively. Each of these users can have the SS-CAD authorization restriction which requires the dispatcher authorization at call set-up. The calling user A shall be informed when SS-CAD is invoked. There shall be no SS-CAD related indication to the called user.

Different dispatchers can be requested to authorize the call if SS-CAD is activated for either user A or user B. The following rules shall apply:

- if user A and user B are present in the same SwMI and both have SS-CAD invoked towards the same dispatcher, only one authorization shall be requested;
- if user A and user B are present in the same SwMI and both have SS-CAD invoked towards different dispatchers, then it is outside the scope of this ETS if more than one dispatcher authorizes the call;
- if user A and user B are in different SwMIs, both SwMIs shall analyse if SS-CAD may be invoked. If invoked for both for both users, both the user A and the user B dispatcher shall be requested to authorize the call in sequence;
- if user A migrates to another SwMI outside its own home SwMI, the SS-CAD subscriber data shall follow it to the visited SwMI if SS-CAD shall be invoked there. It is optional for the visited SwMI to support invocation of SS-CAD;



- if user B migrates to another SwMI outside its own home SwMI, SS-CAD against incoming calls is normally operated in the home SwMI, but the SS-CAD subscriber data shall follow user B to the visited SwMI if SS-CAD shall be invoked against incoming calls originating from that visited SwMI (intra-SwMI calls). It is optional for the visited SwMI to support invocation of SS-CAD;
- if user B has migrated to another SwMI outside its own home SwMI and that SwMI coincides with the originating SwMI and the originating SwMI has first routed a call to user B to user B home SwMI (instead of applying an intra-SwMI call), then that SwMI should not operate SS-CAD against that incoming call to user B as the call at that moment is already authorized in the home SwMI of user B.

If a subscriber is migrating, the authorization shall, by default, be carried out by the subscribers' home dispatcher. Upon agreement between the network operators, the SS-CAD authorization migrated user A and/or user B may be carried out by the dispatcher of the visited SwMI.

Additional CAD restrictions can then be applied by the visiting SwMI to a migrating subscriber.

The functional model for SS-CAD shall comprise the following Functional Entities (FEs):

- FE1 calling user A's agent;
- FE2 CAD control entity in the SwMI where SS-CAD is invoked and a generic transport function, see ETS 300 392-9 [7];
- FE3 authorized user's agent;
- FE7 dispatcher agent.

The following relationships shall exist between these FEs:

- ra between FE1 and FE2;
- rb between FE2 and FE2 in different SwMIs;
- rc between FE7 and FE2;
- rd between FE3 and FE2.

Figure 1 and 2 show the FEs and their relationships.

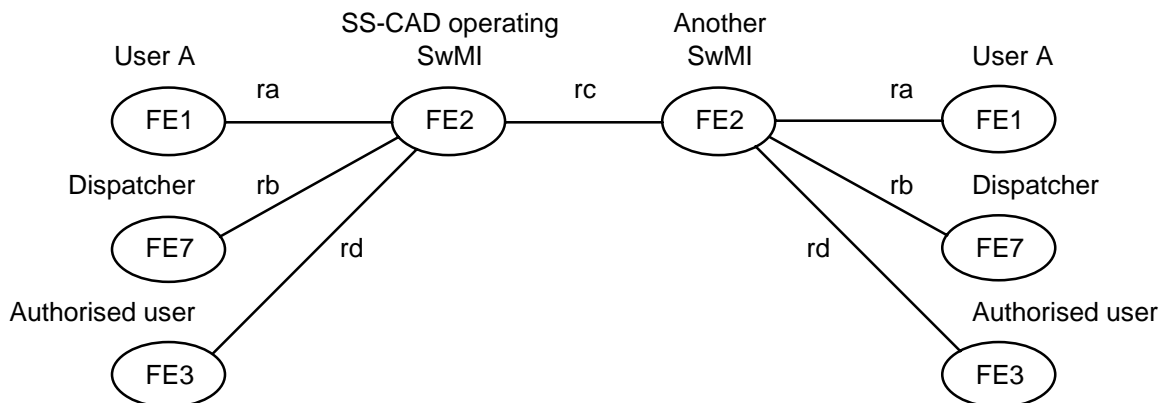

**Figure 1: Functional model for the operational part of SS-CAD**

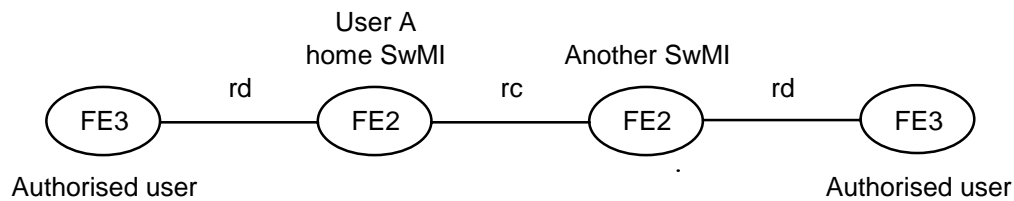

**Figure 2: Functional model for the management part of SS-CAD**

## 4.2 Description of FEs

### 4.2.1 Calling/restricted user A's functional entity, FE1

At the reception of notifications of the CAD interception from FE2, FE1 may deliver them to the calling user A.

### 4.2.2 CAD control functional entity, FE2

This functional entity:

- shall, for each new call establishment from user A, determine if the SS-CAD is activated and shall be invoked due to any of the following optional conditions related to either user A or user B:
  - 1) restricted basic service request;
  - 2) restricted destination or source address;
  - 3) restricted area.

NOTE: In addition there may be network dependent restriction reasons which are outside the scope of this ETS.

- shall invoke call interception by sending information to the dispatcher functional entity FE7, if any of the interception conditions are met;
- shall initiate disconnection of the call if call rejection is received from FE7;
- shall generate and relay to FE1 the call interception notifications addressed to user A;
- shall receive instructions and perform actions for activation/deactivation and interrogation of SS-CAD from FE7;
- shall receive instructions and perform actions for acceptance, rejection and diversion from FE7;
- shall receive instructions and perform actions for definition, activation, deactivation and interrogation of SS-CAD from FE3;
- shall return responses to FE3 regarding requests for definition, activation, deactivation and interrogation of SS-CAD.

For general inter system inter-working this functional entity:

- shall deliver call interception notifications to the user A agent FE1 received from FE2 in another SwMI where SS-CAD has been invoked;
- shall deliver call interception notifications to the dispatcher agent FE7 received from FE2 in another SwMI where SS-CAD has been invoked;
- shall receive responses from the dispatcher agent FE7 which are sent back to FE2 in the other SwMI;

- shall relay information to and from the authorized user functional entity FE3 when the authorized user addresses FE2 of another SwMI.

Refer to ETS 300 392-9 [7] for further details on FE2 subdivision.

#### **4.2.3 Authorized user's functional entity, FE3**

This functional entity shall:

- receive requests from the authorized user regarding activation, deactivation, and interrogation and pass these on to FE2;
- receive corresponding responses and information from FE2 and deliver them to the authorized user.

#### **4.2.4 Dispatcher user's functional entity, FE7**

This FE shall deliver call interception notifications received from FE2 to the dispatcher. It shall also receive responses from the dispatcher which are sent back to FE2.

When indication is received that CAD is invoked, the dispatcher shall either request immediate continuation of the original call or redirect the call to the dispatcher for further authorization or rejection or, if the authorization request is not accepted, immediately request disconnection of the initial call.

#### **4.2.5 Relationship of functional model to basic call functional model**

Functional entity FE1 shall be co-located with the calling user A's Call Control Agent (CCA) in a home or in a visited SwMI.

Functional entity FE2 shall be co-located with the Call Control entity within that TETRA Switching and Management Infrastructure (SwMI) where the SS-CAD is invoked.

Functional entity FE7 shall be co-located with the intercepted-to dispatcher's CCA in the SwMI where the dispatcher is located.

Functional entity FE2 shall be located within that TETRA SwMI where the SS-CAD is not invoked but where the user A or the dispatcher is located.

Functional entity FE3 shall be co-located with the authorized user's CCA.

Called user B's CCA is not co-located with any FE for SS-CAD.

Examples of a relationship between the FEs for SS-CAD and the FEs for the basic call are shown in figures 3 to 14.

## **5 Information flows**

This clause defines information flow names and contents in general terms. The information flows will be transformed into real PDUs in stage 3, refer ETS 300 392-12-6 [2]. In some cases an information flow defined in this part will be an element or a value of an element of a CC PDU, refer ETS 300 392-2 [3], subclauses 14.7 and 14.8, and ETS 300 392-9 [7].

### **5.1 Definition of information flows**

In the following subclauses, in the tables listing the elements in information flows, the column headed "Type" indicates which of these elements are Mandatory (M) and which are Optional (O).

#### **5.1.1 ACCEPT**

ACCEPT is an unconfirmed information flow across rd and rc from FE7 to FE2 which indicates to FE2 that the dispatcher has authorized the call and that the call set-up to user B can continue. Table 1 lists the elements within the ACCEPT information flow.

This information flow shall be mandatory to FEs which support authorization.

**Table 1: Contents of ACCEPT**

Element	Type
Call identifier	M

**5.1.2 ACCEPTED**

ACCEPTED is an unconfirmed information flow across ra and rc from FE2 to FE1 which indicates to FE1 that the dispatcher has authorized the call and that the call set-up will continue. Table 2 lists the elements within the ACCEPTED information flow.

This information flow shall be optional to FEs which support calling user guidance.

**Table 2: Contents of ACCEPTED**

Element	Type
Call identifier	M

**5.1.3 ACTIVATE**

ACTIVATE is a confirmed information flow across rd and rc from FE3 to FE2 which indicates to FE2 that the authorized user wants the SS-CAD activated. Table 3 lists the valid elements within the ACTIVATE information flow.

This information flow shall be mandatory to FEs which support activation.

**Table 3: Contents of ACTIVATE**

Element	Type
Restricted user TETRA identity(ies)	M
Intercepting dispatcher identity(ies)	O

**5.1.4 ACTIVATE ACK**

ACTIVATE ACK is an information flow across rd and rc from FE2 to FE3. Table 4 lists the elements within the ACTIVATE ACK information flow.

This information flow shall be mandatory to FEs which support activation.

**Table 4: Contents of ACTIVATE ACK**

Element	Type
Restricted user TETRA identity(ies)	M
Activation result	M

**5.1.5 CANCEL**

CANCEL is an unconfirmed information flow across rb and rc from FE2 to FE7 which indicates to FE7 that the originator of the call has disconnected. Table 5 lists the elements within the CANCEL information flow.

This information flow is optional to FEs which support authorization guidance.

**Table 5: Contents of CANCEL**

Element	Type
Call identifier	M

**5.1.6 DEACTIVATE**

DEACTIVATE is a confirmed information flow across rd and rc from FE3 to FE2. Table 6 lists the elements within the DEACTIVATE information flow.

This information flow shall be mandatory to FEs which support activation.

**Table 6: Contents of DEACTIVATE**

Element	Type
Restricted user TETRA identity(ies)	M

**5.1.7 DEACTIVATE ACK**

DEACTIVATE ACK is an information flow across rd and rc from FE2 to FE3. Table 7 lists the elements within the DEACTIVATE information flow.

This information flow shall be mandatory to FEs which support activation.

**Table 7: Contents of DEACTIVATE ACK**

Element	Type
Restricted user TETRA identity(ies)	M
Deactivation result	M

**5.1.8 DEFINE**

DEFINE is a confirmed information flow across rd and rc from FE3 to FE2 which indicates to FE2 that the authorized user wants to define the parameters for SS-CAD. Table 8 lists the valid elements within the DEFINE information flow.

The DEFINE can be used for modifications.

This information flow shall be mandatory to FEs which support definition.

**Table 8: Contents of DEFINE**

Element	Type
Restricted user TETRA identity(ies)	M (note 1)
Activate/deactivate	M (note 2)
Intercepting dispatcher identity(ies)	O (note 3)
Interception type	O (note 4)
Basic service restrictions incoming calls	O (note 5)
Basic service restrictions outgoing calls	O (note 6)
Restricted source identity range	O (note 7)
Restricted destination identity range	O (note 8)
Restricted area list	O (note 9)
NOTE 1: This element indicates which TETRA user or users (ITSI(s) or GTSI(s)) which shall be restricted with the SS-CAD.	
NOTE 2: This element indicates if the CAD restrictions shall be activated or deactivated at definition.	
NOTE 3: This element indicates the address (ITSI) of the dispatcher responsible for the authorization of restricted calls. This element is applicable only when service is also activated.	
NOTE 4: This element defines if immediate set-up or dispatcher requested set-up shall be applied.	
NOTE 5: This element indicates that incoming calls of this basic service type to a restricted user shall be diverted to the dispatcher, according to the basic service information field in ETS 300 392-2 [3], subclause 14.8.	
NOTE 6: This element indicates that outgoing calls of this basic service type from a restricted user shall be diverted to the dispatcher, according to the basic service information field in ETS 300 392-2 [3], subclause 14.8.	
NOTE 7: This element is the identity of a source from which incoming calls to the restricted user(s) shall be diverted to the dispatcher.	
NOTE 8: This element is the identity of a destination to which outgoing calls from the restricted user(s) shall be diverted to the dispatcher.	
NOTE 9: This element is a list of areas for outgoing calls from the restricted user(s). The area definitions of the authorized user shall be used.	

**5.1.9 DEFINE ACK**

DEFINE ACK is an information flow across rd and rc from FE2 to FE3. Table 9 lists the elements within the DEFINE information flow.

This information flow shall be mandatory to FEs which support definition.

**Table 9: Contents of DEFINE ACK**

Element	Type
Restricted user TETRA identity(ies)	M
Definition result	M

**5.1.10 DIVERT**

DIVERT is an unconfirmed information flow across rb and rc from FE7 to FE2 which indicates to FE2 that the call from user A shall be redirected to the dispatcher for authorization. Table 10 lists the elements within the DIVERT information flow.

This information flow shall be mandatory to FEs which support authorization.

**Table 10: Contents of DIVERT**

Element	Type
Call identifier	M

### 5.1.11 DIVERTED

DIVERTED is an unconfirmed information flow across ra and rc from FE2 to FE1 which indicates to FE1 that the call has been diverted to the dispatcher for authorization. Table 11 lists the elements within the DIVERTED information flow.

This information flow shall be mandatory to FEs which support calling user guidance.

**Table 11: Contents of DIVERTED**

Element	Type
Call identifier	M
Interception cause	M (note)
Intercepting dispatcher identity	O
NOTE:	This element indicates the cause of interception: <ul style="list-style-type: none"> <li>- not defined;</li> <li>- restricted basic service;</li> <li>- restricted destination address;</li> <li>- restricted source address;</li> <li>- restricted area;</li> <li>- network restriction.</li> </ul>

### 5.1.12 INTERCEPTED

INTERCEPTED is an unconfirmed information flow across ra and rc from FE2 to FE1 which indicates to FE1 that the call interception has been initiated. Table 12 lists the elements within the INTERCEPTED information flow.

This information flow shall be mandatory to FEs which support calling user guidance.

**Table 12: Contents of INTERCEPTED**

Element	Type
Call identifier	M
Interception cause	M (note)
Intercepting dispatcher identity	O
NOTE:	Refer table 11 for element usage.

### 5.1.13 INTERROGATE

INTERROGATE is a confirmed information flow across rd and rc from FE3 to FE2 which indicates to FE2 that the authorized user interrogates the SS-CAD profile of the restricted user. Table 13 lists the elements within the INTERROGATE information flow.

This information flow shall be mandatory to FEs which support interrogation.

**Table 13: Contents of INTERROGATE**

Element	Type
Restricted user TETRA identity	M

**5.1.14 INTERROGATE ACK**

INTERROGATE ACK is an information flow across rd and rc from FE2 to FE3. Table 14 lists the elements within the INTERROGATE ACK information flow.

This information flow shall be mandatory to FEs which support interrogation.

**Table 14: Contents of INTERROGATE ACK**

Element	Type
Restricted user TETRA identity	M
Intercepting dispatcher identity	M
Activation indicator	O
Restricted basic services - incoming	O
Restricted basic services - outgoing	O
Restricted source address list	O
Restricted destination address list	O
Restricted area list	O
NOTE: Refer table 8 for elements usage.	

**5.1.15 REJECT**

REJECT is an unconfirmed information flow across rb and rc from FE7 to FE2 which indicates to FE2 that the dispatcher has rejected the call and that the call shall be disconnected. Table 15 lists the elements within the REJECT information flow.

This information flow shall be mandatory to FEs which support authorization.

**Table 15: Contents of REJECT**

Element	Type
Call identifier	M
Rejection cause	M (note)
NOTE: Refer table 11 for element usage.	

**5.1.16 REJECTED**

REJECTED is an unconfirmed information flow across ra and rc from FE2 to FE1 which indicates to FE1 that the dispatcher has rejected the call to user B to continue and that the call will be disconnected. Table 16 lists the elements within the REJECTED information flow.

This information flow shall be mandatory to FEs which support calling user guidance.

**Table 16: Contents of REJECTED**

Element	Type
Call identifier	M
Intercepting dispatcher identity	O
Rejection cause	M (note)
NOTE: Refer table 11 for element usage.	



### 5.1.17 REQUEST

REQUEST is an unconfirmed information flow across rb and rc from FE2 to FE7 which indicates to FE7 that the call interception is taking place and the reason for the interception. Table 17 lists the elements within the REQUEST information flow.

This information flow shall be mandatory to FEs which support authorization.

**Table 17: Contents of REQUEST**

Element	Remark
Call identifier	M
Interception cause	M (see table 11)
Interception type	M (note 1)
Calling user identity	O (note 2)
Called user identity	O (note 3)
Restricted area number - calling user	O (note 3)
Restricted area number - called user	O (note 3)
Basic service restriction - calling user	O (note 3)
Basic service restriction - called user	O (note 3)
NOTE 1:	This element shall define if immediate set-up or dispatcher requested set-up is valid for this request.
NOTE 2:	The information in this element may not be available (e.g. PSTN subscriber number).
NOTE 3:	This element shall be included if it is the reason for the interception.

## 5.2 Relationship of information flows to basic call information flows

The SS-CAD information flows shall be related with the basic call PDUs as defined in table 18. Over ISI the basic call flow name is preceded by an "ISI" instead of "U" or "D".

NOTE: U/D-FACILITY is a supplementary service flow and not a basic call flow.

**Table 18: Relationship of the SS\_CAD information flows with the basic call**

Information flow		Independent of basic call flow	With basic call flow	Basic call flow
ACCEPT	request	yes	yes	U-DISCONNECT U-FACILITY U-INFO
ACCEPTED	indication	no	yes	D-CALL PROCEEDING D-CONNECT D-ALERT D-INFO ISI-THROUGH CONNECT
ACTIVATE	request	yes	no	U-FACILITY
ACTIVATE ACK	request	yes	no	D-FACILITY
ACTIVATE DEACTIVATE	request	yes	no	U-FACILITY
ACTIVATE ACK DEACTIVATE ACK	indication	yes	no	D-FACILITY
CANCEL	indication	yes	no	D-FACILITY
DEFINE	request	yes	no	U-FACILITY
DEFINE ACK	indication	yes	no	D-FACILITY
DIVERT	request	yes	no	U-FACILITY
DIVERTED	indication	no	yes	D-ALERT D-CALL PROCEEDING D-CONNECT D-INFO
INTERCEPTED	indication	no	yes	D-CALL PROCEEDING D-INFO
INTERROGATE	request	yes	no	U-FACILITY
INTERROGATE ACK	indication	yes	no	D-FACILITY
REJECT	request	yes	yes	U-DISCONNECT U-FACILITY
REJECTED	indication	no	yes	D-DISCONNECT D-RELEASE
REQUEST	indication	yes	yes	D-FACILITY D-SETUP

## 5.3 Service primitives

This subclause lists SS CAD service primitives used to invoke or being a result of information flow sequences. The SS-CAD service primitives are defined in ETS 300 392-12-6 [2], subclause 5.2 and the basic call service primitives are defined in ETS 300 392-2 [3], clause 11.

The SS-CAD service primitives at the restricted user MS/LS (FE1) TNSS-SAP are:

- a) ACCEPTED indication;
- b) DIVERTED indication;
- c) INTERCEPTED indication;
- d) REJECTED indication.

The SS-CAD service primitives at the authorized user MS/LS (FE3) TNSS-SAP are:

- a) ACTIVATE request;
- b) ACTIVATE confirm;
- c) DEACTIVATE request;
- d) DEACTIVATE confirm;
- e) DEFINE request;
- f) DEFINE indication;
- g) INTERROGATE request;
- h) INTERROGATE confirm.

The SS-CAD service primitives at the dispatcher MS/LS (FE7) TNSS-SAP are:

- a) ACCEPT request;
- b) CANCEL indication;
- c) DIVERT request;
- d) REJECT request;
- e) REQUEST indication.

The dispatcher may also use activate, deactivate and interrogate processes as defined for the authorized user.

#### 5.4 Information flow sequences

Signalling procedures in support of the information flow sequences are specified below. In addition, signalling procedures covering other sequences arising from error situations, interactions with other supplementary services, different topologies etc. are shown.

In the figures, SS-CAD information flows are represented by solid arrows and basic call information flows including U/D-FACILITY are represented by broken arrows. When two information flows occur at the same time in the example flow charts they are embraced by an ellipse. The ellipse does not imply that other combinations of information flows are not allowed, refer to table 17. Within a column representing a SS-CAD functional entity, the numbers refer to functional entity actions listed in subclause 5.5.

The naming of basic call information flows over ISI may not exactly correspond to the naming of information flows and PDUs used in the TETRA ISI standard, refer e.g. ETS 300 392-3-2 [5].

##### 5.4.1 Normal operation

There are three different optional behaviours related to the authorization procedure:

- authorization without a voice call set-up to the dispatcher;
- authorization with a voice call set-up "On demand" after request from the dispatcher;
- authorization with a "Direct" voice call set-up to the dispatcher.

Subclauses 5.4.2 to 5.4.8 present scenarios where user A and dispatcher are in the same SwMI. These scenarios are valid also if user A and dispatcher are both migrated into the same SwMI which also operates the SS-CAD.

Subclauses 5.4.9 to 5.4.14 present where user A, dispatcher and/or operating SS-CAD entity are in different SwMIs.

These scenarios are independent of location of user B as after an authorization the call proceeds as a basic call. The proceeding call may invoke another SS-CAD, which will be independent of the previous SS-CAD invocation.

NOTE 1: Call control information flow sequences may be incomplete as some CC information flows should not affect to the SS-CAD functionality or user behaviour.

NOTE 2: The information flows does not show call completion after the authorization.

Subclauses 5.4.15 to 5.4.21 present SS-CAD management scenarios.

**5.4.2 Successful interception without call set-up to dispatcher in home SwMI**

Figure 3 shows the information flow sequence for a successful interception of a call from user A without call set-up to the dispatcher. User A and/or user B has SS-CAD activated in the home SwMI.

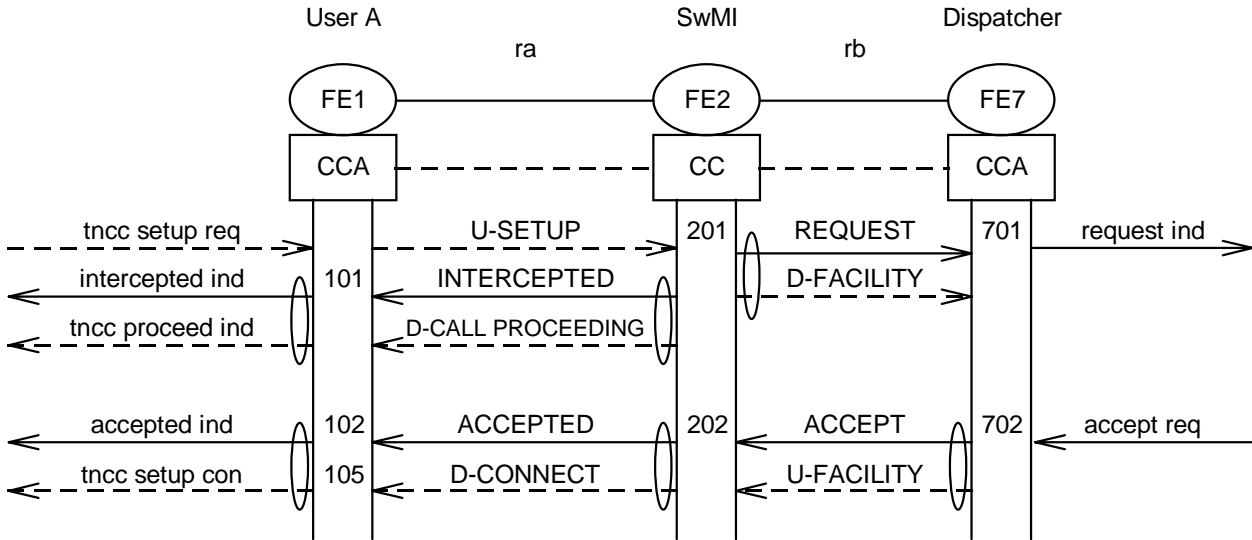

**Figure 3: Successful interception without call set-up to the dispatcher**

**5.4.3 Successful interception with "on-demand" call set-up to the dispatcher**

Figure 4 shows the information flow sequence for a successful interception of a call from user A with "on-demand" call set-up requested by the dispatcher.

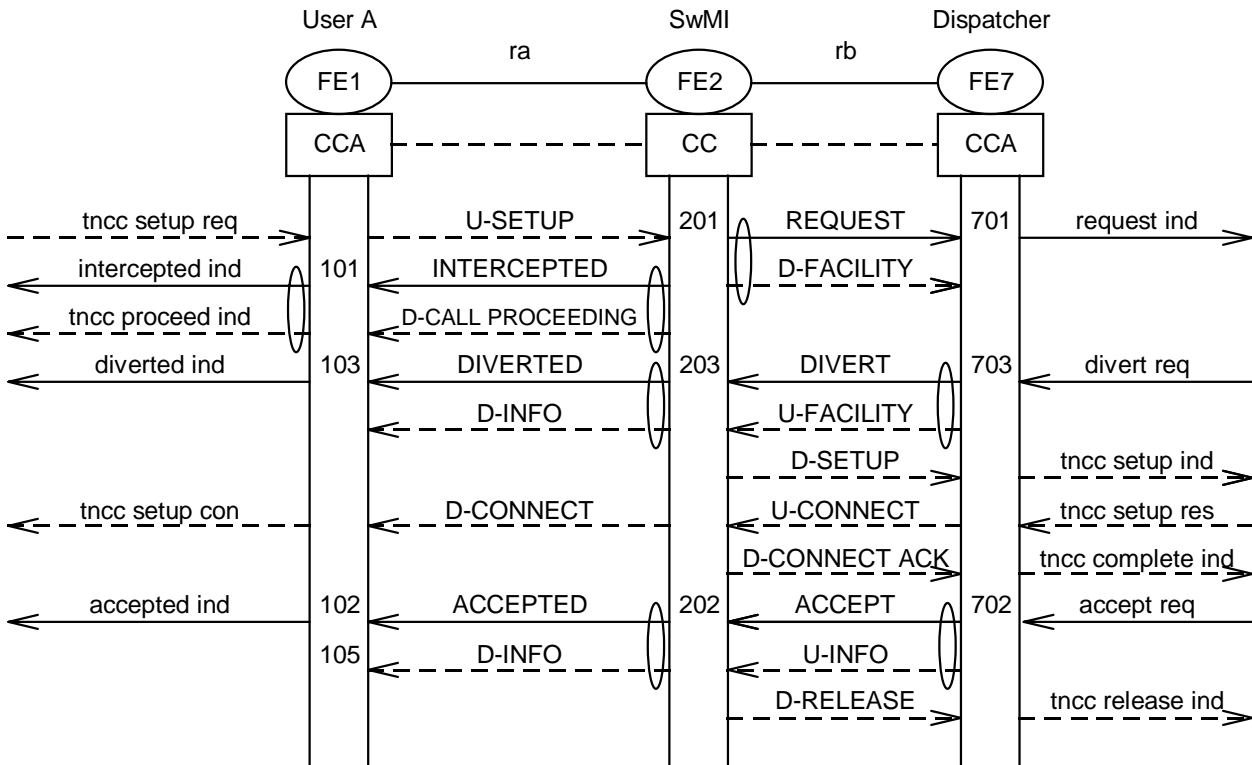

**Figure 4: Successful interception with "on-demand" call set-up to the dispatcher**

5.4.4 Successful interception with Direct call set-up to the dispatcher

Figure 5 shows the information flow sequence for a successful interception of a call from user A with automatic call set-up to the dispatcher.

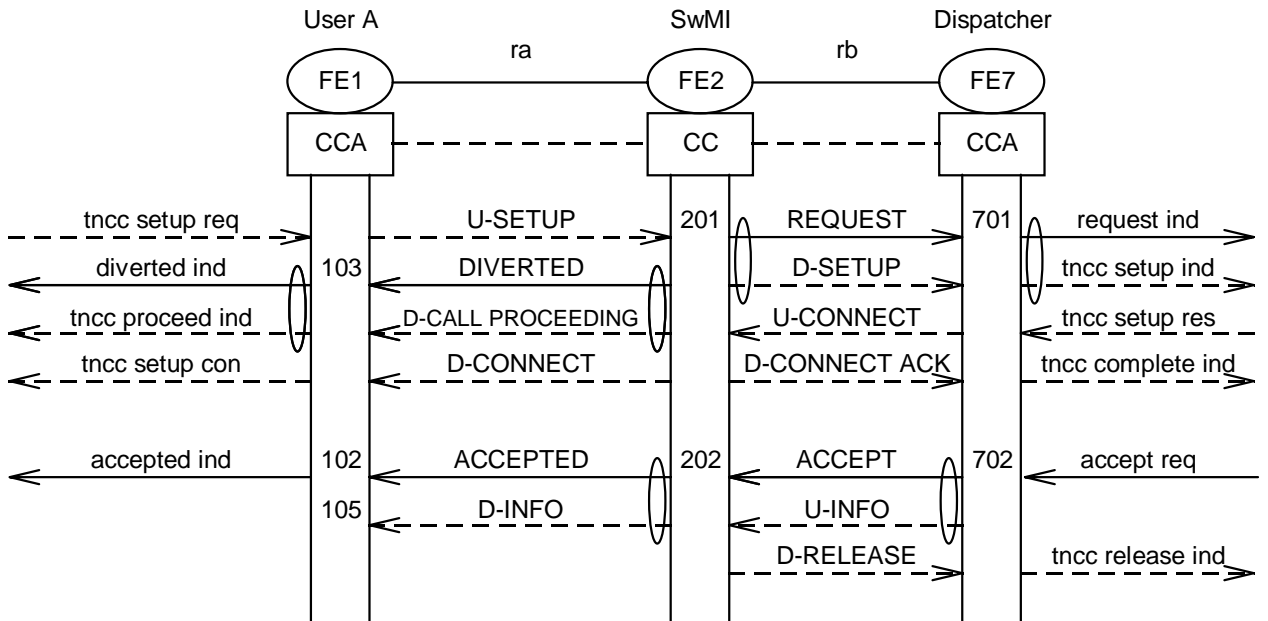

Figure 5: Successful interception with direct call set-up to the dispatcher

5.4.5 Rejection of call without call set-up to the dispatcher

Figure 6 shows the information flow sequence of a call from user A rejected by the dispatcher after successful interception of a call from user A with call set-up to the dispatcher. SwMI may send REJECTED information flow without sending an INTERCEPTED information flow.

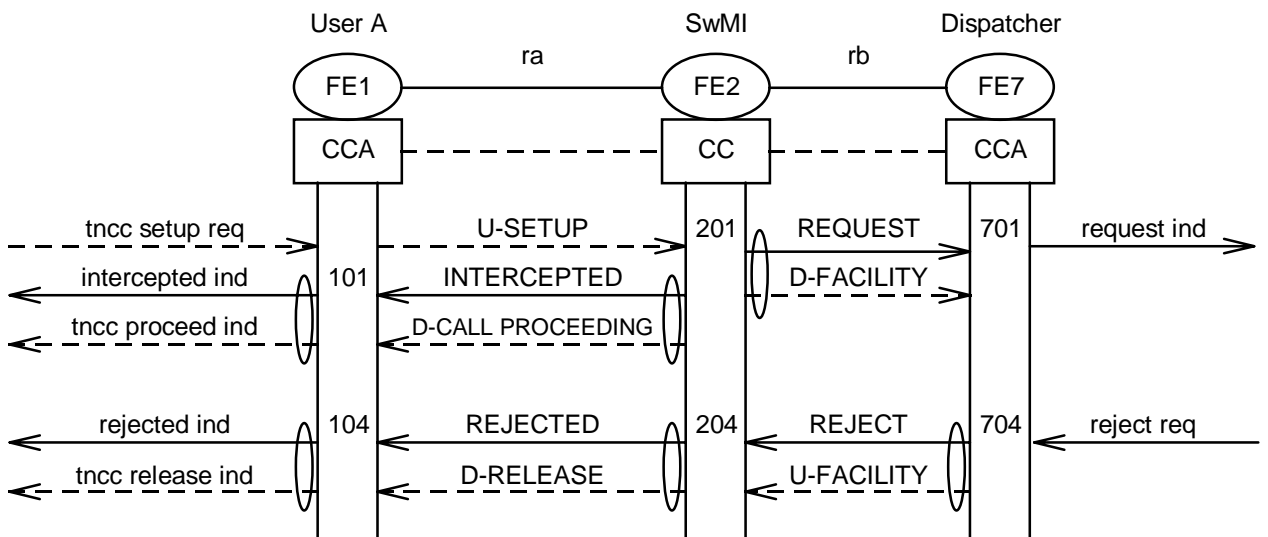

Figure 6: Rejection of call without call set-up to the dispatcher

5.4.6 Rejection of call after call set-up to the dispatcher

Figure 7 shows the information flow sequence for a rejected call from user A with call set-up to the dispatcher.

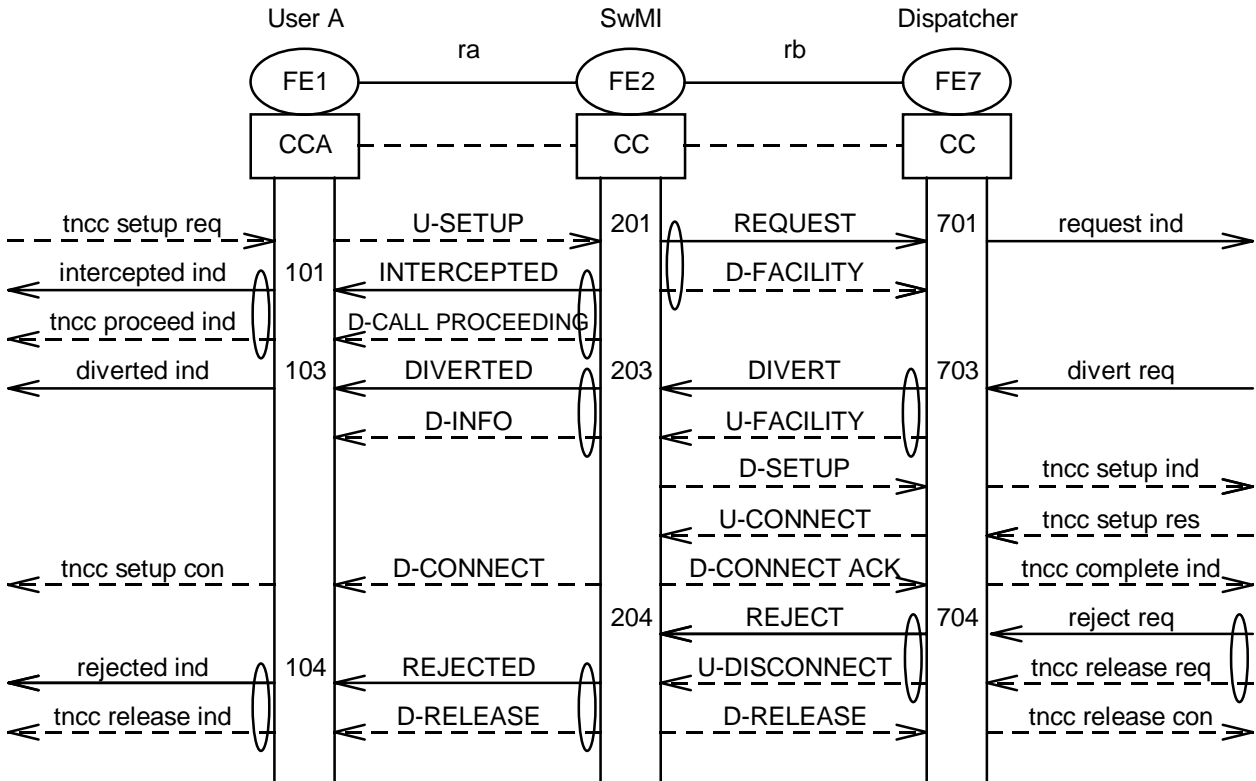

Figure 7: Rejection of call after call set-up to the dispatcher

5.4.7 Calling user A disconnects the call during interception

Figure 8 shows the information flow sequence when the calling user disconnects the call during interception before any connection has been set-up to the dispatcher.

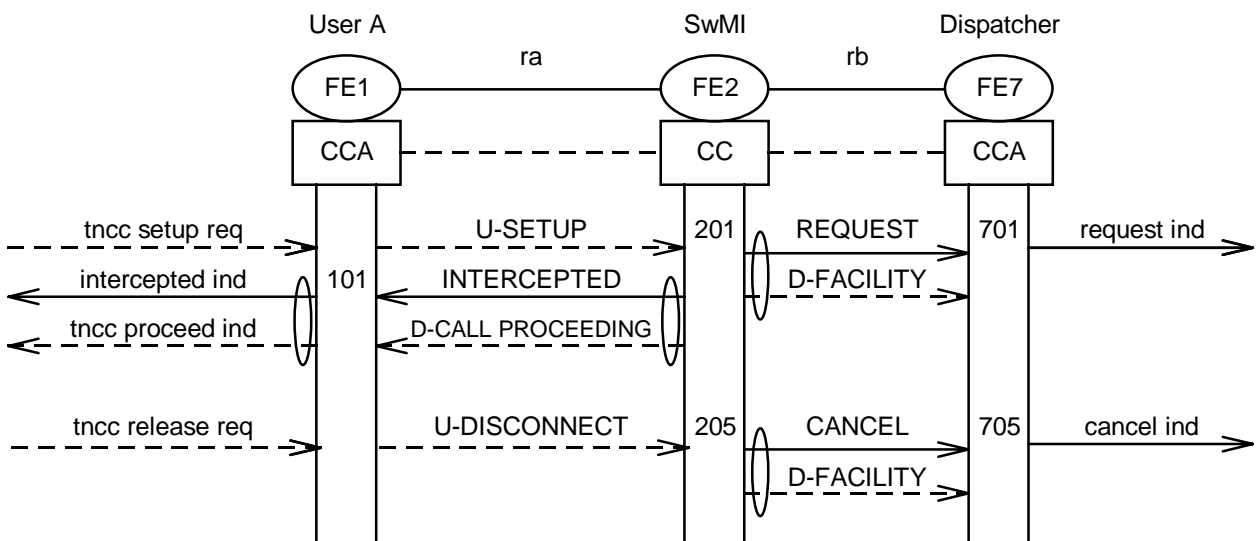
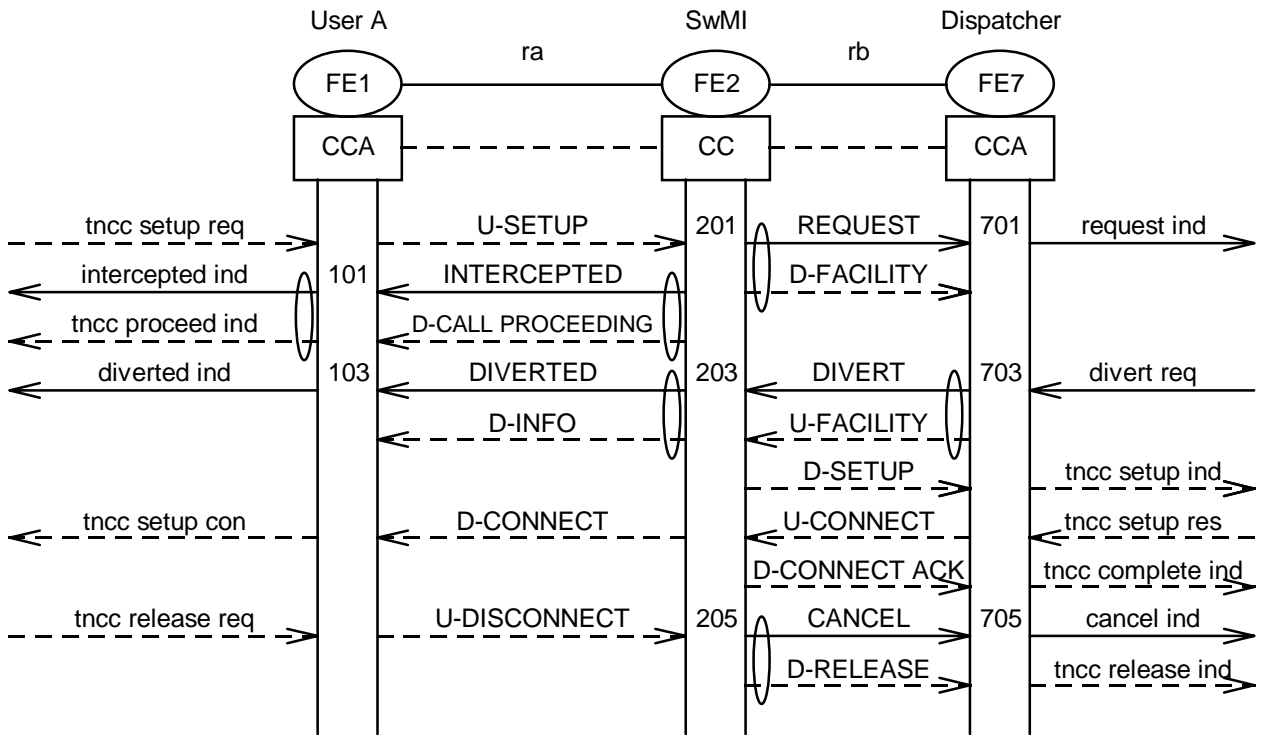

Figure 8: Calling user A disconnects during interception

**5.4.8 Calling user A disconnects when connection is established to the dispatcher**

Figure 9 shows the information flow sequence when the calling user disconnects the call during interception after a connection has been set-up to the dispatcher.



**Figure 9: Calling user A disconnects after call set-up to the dispatcher**

**5.4.9 User A in home SwMI, authorization in user A home SwMI with the dispatcher migrated into another SwMI**

This scenario describes as presented in figure 10 authorization with direct call set-up when user A and user B are in their home SwMI. The dispatcher is in another SwMI. CAD is activated either towards user A or user B. A dispatcher in the visited system is responsible for the authorization.

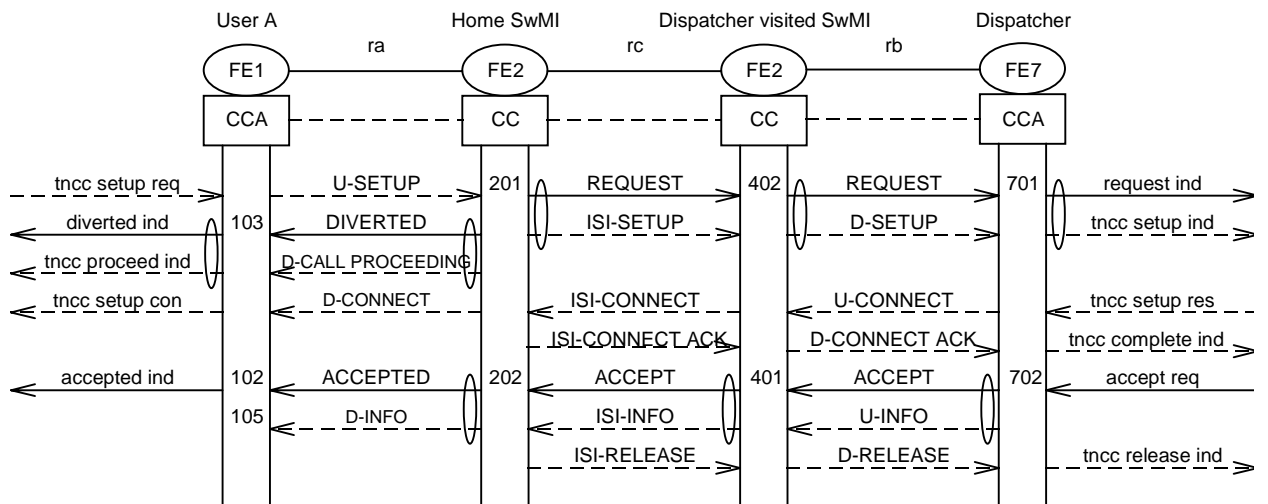

**Figure 10: Authorization in home SwMI with the dispatcher migrated into another SwMI**

5.4.10 Authorization in home SwMI against user B when user A has migrated into another SwMI

This scenario describes as presented in figure 11 authorization with direct call set-up when user A has migrated to another SwMI. The dispatcher and user B are in their home SwMI. CAD is activated towards user B.

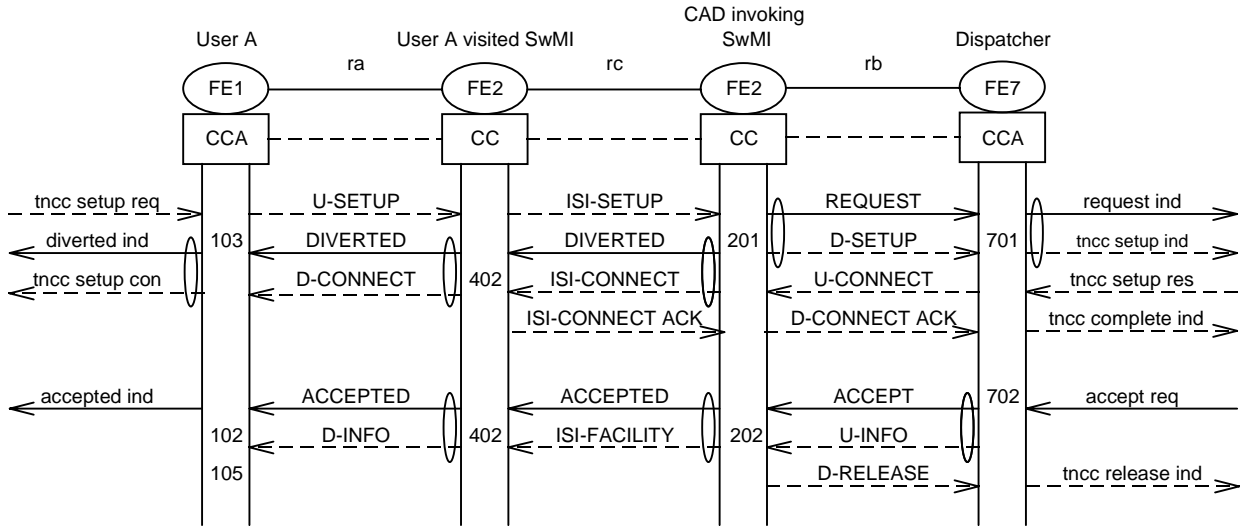

Figure 11: Authorization in user B home SwMI when user A has migrated to another SwMI

5.4.11 Authorization in visited SwMI against user A when user A has migrated into that SwMI

This scenario describes as presented in figure 12 authorization with direct call set-up when user A has migrated to another SwMI. The dispatcher is in the home SwMI. CAD is activated against user A. This scenario assumes that the user A SS-CAD profile is available in the visited SwMI and the visited SwMI operated the SS-CAD.

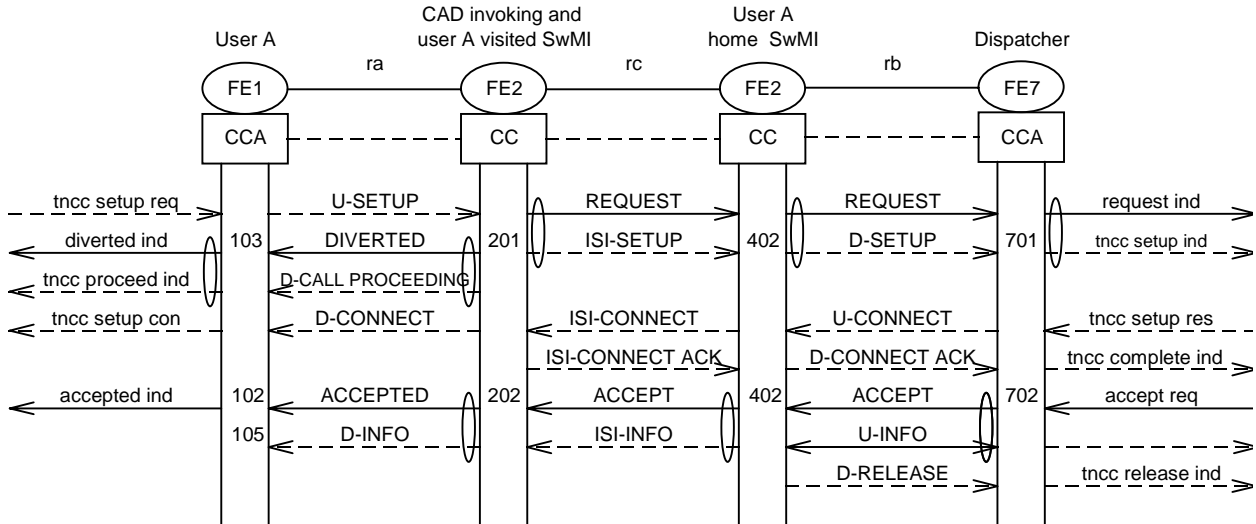
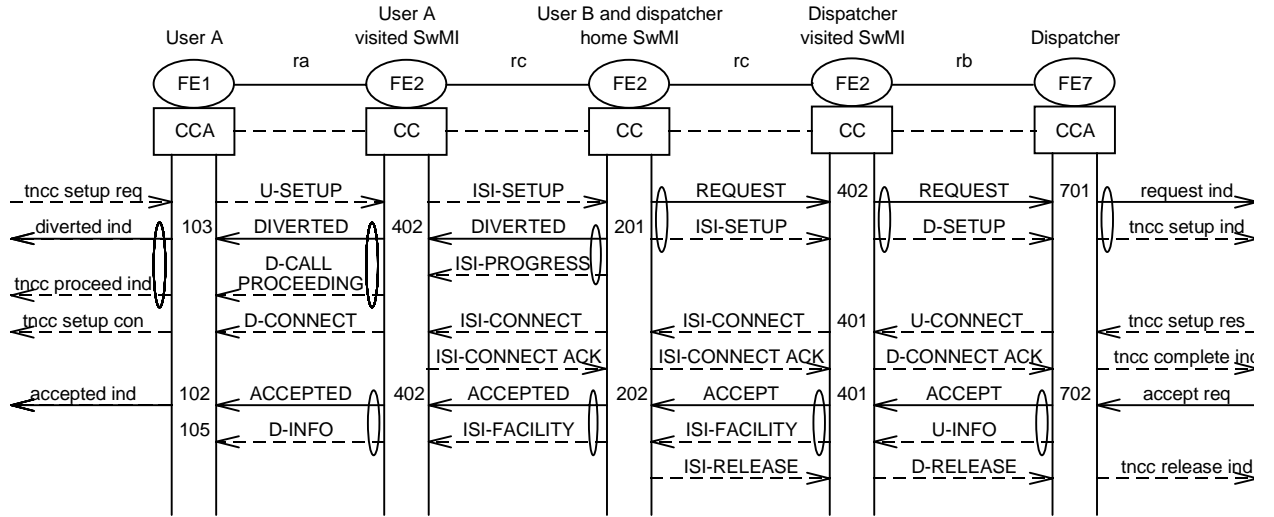

Figure 12: Authorization in visited SwMI when user A has migrated to that SwMI



**5.4.12 Authorization in home SwMI when user A and the dispatcher has migrated into different SwMIs**

This scenario describes as presented in figure 13 authorization in user B home SwMI with direct call set-up, when both user A and the dispatcher have migrated to different SwMIs. The SS-CAD is operated by the user B home SwMI and the dispatcher has migrated into another SwMI as the user A. The DIVERTED information flow to user A may also use other information flows.



**Figure 13: Authorization in home SwMI when user A and the dispatcher has migrated into different SwMIs**

5.4.13 Authorization in user B home SwMI against user B when user A and the dispatcher has migrated into the same SwMI

This scenario describes as presented in figure 14 authorization in user B home SwMI with direct call set-up, when user A and the dispatcher have migrated to the same SwMI. The SS-CAD is operated by the user B home SwMI and the dispatcher can be in the same or another SwMI as the user A.

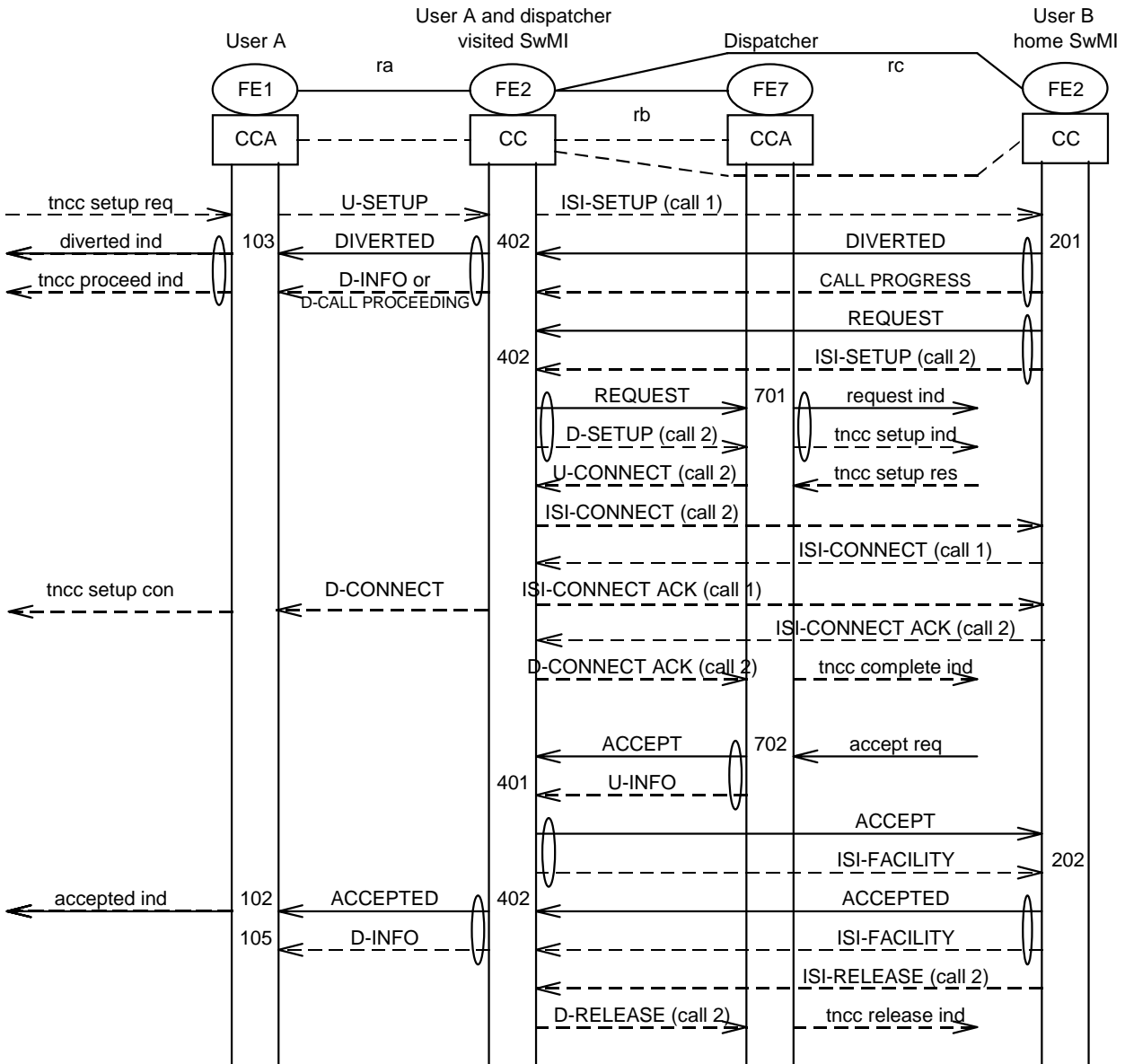

NOTE: A call identifier has been added after the names of the most important ISI basic call information flows shown on the figure: call 1 for the original call, and call 2 for the call from the CAD invoking SwMI (user B home SwMI) to the dispatcher.

Figure 14: Authorization in home SwMI when user A and the dispatcher has migrated into the same SwMI

5.4.14 User A in home SwMI , authorization in another SwMI against user B of the other SwMI

This scenario describes as presented in figure 15 authorization with direct call set-up when user A is in his home SwMI. The user B is in another SwMI. CAD is activated towards user B and the dispatcher in that SwMI is responsible for the authorization. The DIVERTED information flow to user A may also use other information flows.

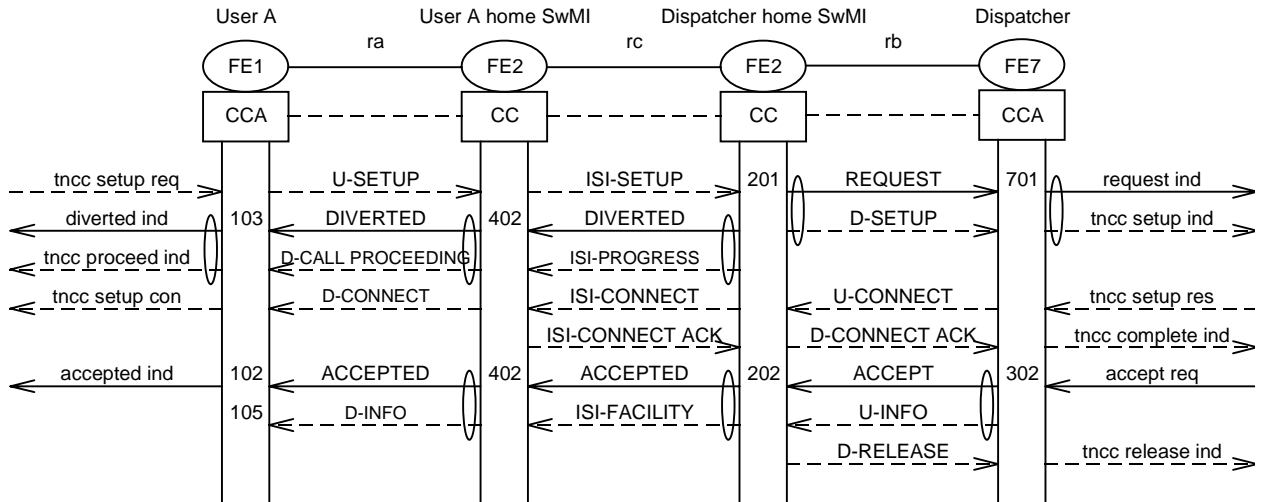

Figure 15: Authorization in called user SwMI when dispatcher is in that SwMI

5.4.15 Call completion

The scenario as presented in figure 16 describes call set-up completion when user A is in another SwMI than the one which operates the SS-CAD and the call diverted to the dispatcher. The ACCEPTED information flow may use also other information flows.

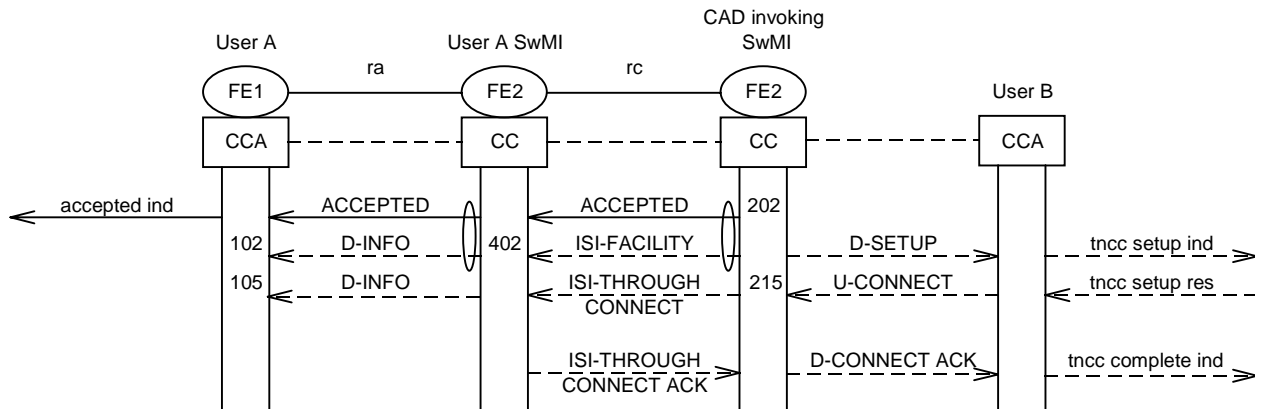

Figure 16: Call completion

- NOTE 1: For further information see ETS 300 392-3-2 [5]. In case of conflict the latter applies.
- NOTE 2: The "CAD invoking SwMI" in figure 16 is the same as the "Home SwMI" in figure 10, the "User B and dispatcher home SwMI" in figure 13, the "User B home SwMI" in figure 14 and the "Dispatcher home SwMI" in figure 15.

5.4.16 Activation/deactivation information flow

Figure 17 shows the information flow sequence over the rd-route when the authorized user requests activate/deactivate of the CAD service within the same SwMI. If the authorized user wants to request the service in another SwMI as presented in figure 18, the same information flow shall appear between FE3 and FE2 over the rd route in that system and between FE2s over the rc route.

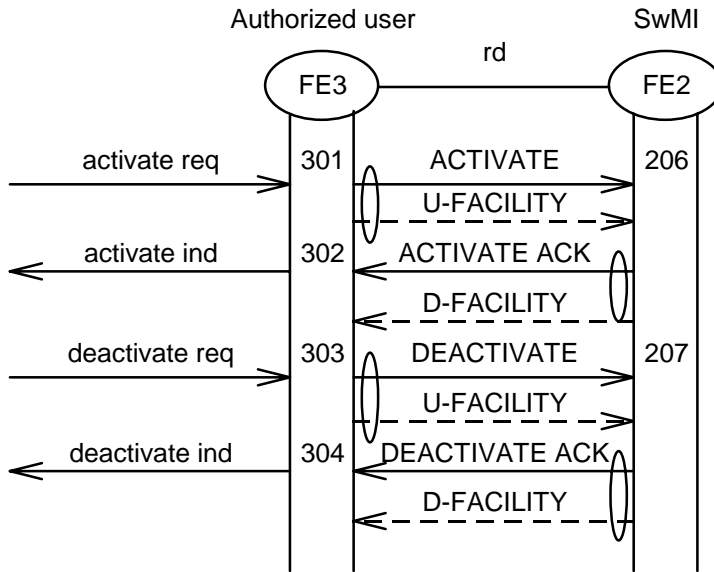

Figure 17: Activation/deactivation request from the authorized user

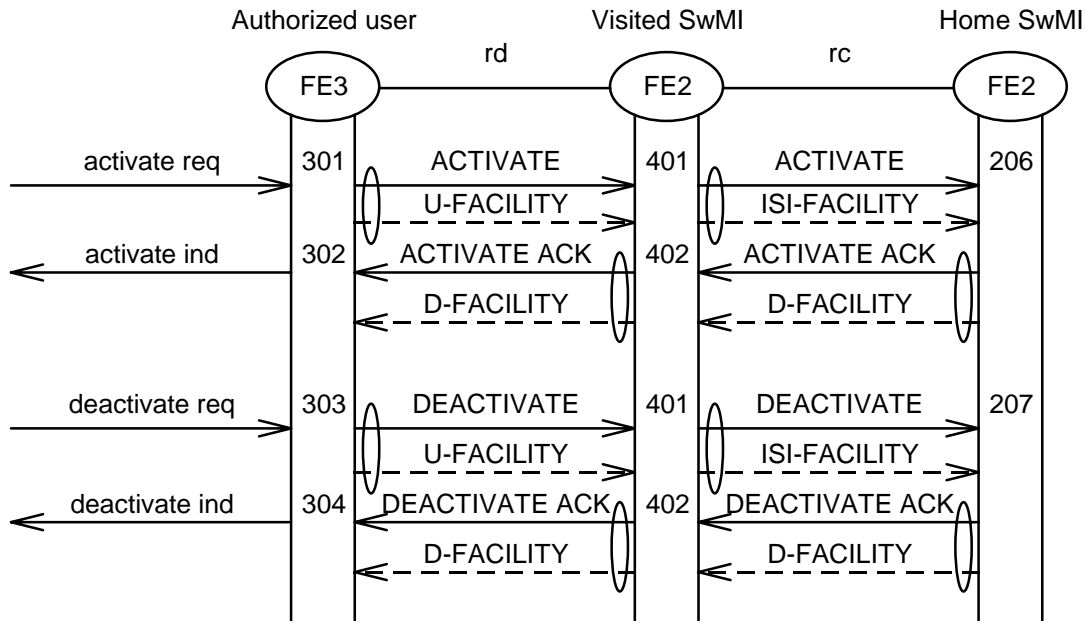

Figure 18: Activation/deactivation request from the authorized user in a visited SwMI

5.4.17 Definition information flow

Figure 19 shows the information flow sequence when the authorized user requests definition of SS-CAD parameters for a restricted user within the same SwMI. If the authorized user requests the definition service in another SwMI as presented in figure 20, the same information flow shall appear between FE3 and FE2 over the rd route of that SwMI and between FE2s over the rc route.

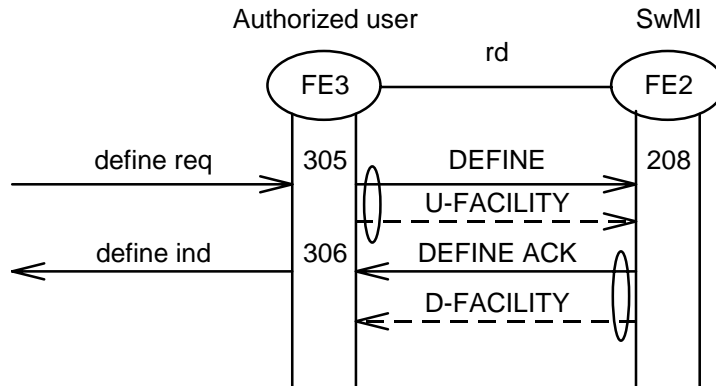

Figure 19: Definition request from the authorized user

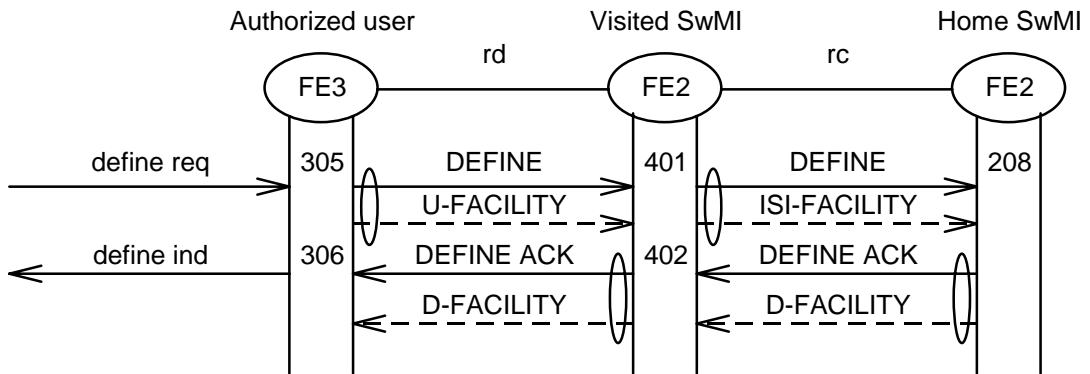

Figure 20: Definition request from the authorized user

5.4.18 Interrogation information flow

Figure 21 shows the information flow sequence when the authorized user interrogates the CAD service within the same SwMI. If the authorized user wants to request this service in another SwMI as presented in figure 22, the same information flow shall appear between FE3 and FE2 over the rd route of that SwMI and between FE2s over the rc route.

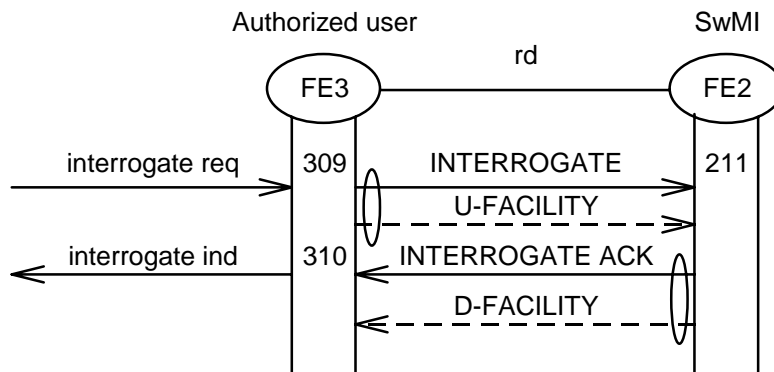

Figure 21: Interrogation request from the authorized user

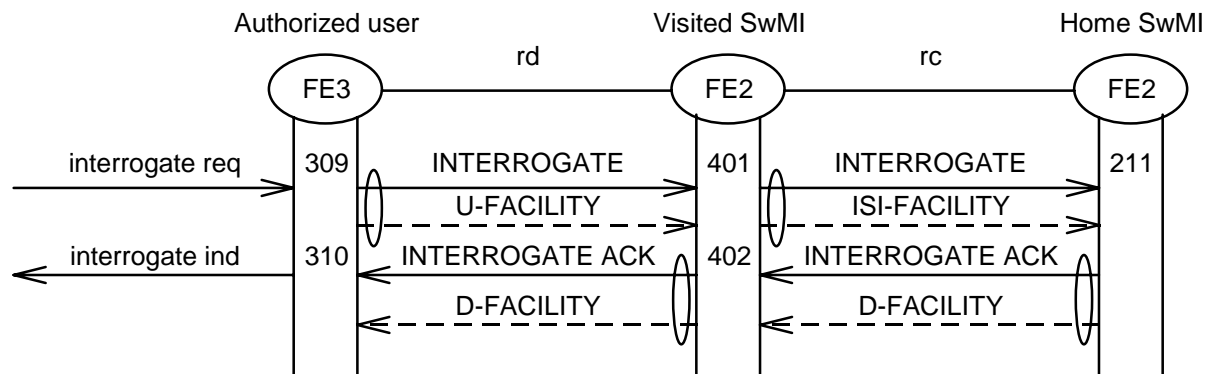

Figure 22: Interrogation request from the authorized user in a visited SwMI

#### 5.4.19 Exceptional operation

If the dispatcher cannot be reached for authorization when CAD is invoked, it shall be an implementation option whether the call set-up request shall be rejected and user A informed about the rejection, or if the call set-up shall be allowed to continue without authorization.

#### 5.5 FE actions

The following FE actions shall occur at the points indicated in figures 3 to 22.

##### 5.5.1 FE actions of FE1

- 101 Delivers notification as received from FE2 in INTERCEPTED to the restricted user that interception of the call has been initiated.
- 102 Delivers notification as received from FE2 in ACCEPTED to the restricted user that the call set-up to user B is continuing after authorization.
- 103 Delivers notification as received from FE2 in DIVERTED to the restricted user that the call set-up to user B is redirected to the dispatcher.
- 104 Delivers notification as received from FE2 in REJECTED to the restricted user that the call set-up to user B has been rejected by the dispatcher and that the call is disconnected.
- 105 When ACCEPTED is received, the CC for user A will continue in the call active state as if there was no interception and the CC state machine will continue as if it had only sent a SETUP request (ignore all CC signalling between DIVERTED and ACCEPTED).

NOTE: The above description of action 105 implies that the call ID for the call to user B remains the same as that for the call to the dispatcher. This allows a MS/LS which does not support a specific SS-CAD protocol to be compatible with this supplementary service operation.

##### 5.5.2 FE actions of FE2

- 201 On receipt of a SETUP request, FE2 shall perform the following actions:
  - analyse if SS-CAD shall be invoked;
  - halt the call set-up if SS-CAD shall be invoked;
  - send a notification in REQUEST to FE7 to indicate that the call has been intercepted;
  - optionally, if direct call set-up is valid, send a notification in DIVERTED to FE1 and start the call set-up between user A and the dispatcher.
  - optionally, if direct call set-up is not valid, send a notification in INTERCEPTED to FE1 indicating to the restricted user that the call has been intercepted.

- 202 On receipt of the ACCEPT from FE7, FE2 shall perform the following actions:
- stimulate the continuation of the original call set-up to user B;
  - if the leg rb to FE7 has been set-up, stimulate the release of this leg;
  - send a notification in ACCEPTED to FE1 indicating to the restricted user that the call attempt has been approved and the initial call set-up will continue.
- 203 On receipt of the DIVERT from FE7, FE2 shall perform the following actions:
- stimulate redirection of the call to the dispatcher;
  - send a notification in DIVERTED to FE1 indicating to the restricted user that the call shall be redirected to the dispatcher.
- 204 On receipt of the REJECT from FE7, FE2 shall perform the following actions:
- stimulate the release procedure at the leg towards the restricted user;
  - send a notification in REJECTED to FE1.
- 205 On receipt of a DISCONNECT request from FE1, FE2 shall send a notification of the disconnection in CANCEL to FE7.
- 206 On receipt of the ACTIVATE request from FE3 or FE7, FE2 shall perform the following actions:
- verify that the restricted users identity is within the jurisdiction of the authorized user;
  - activate SS-CAD dependent on the implementation option;
  - send a confirmation in ACTIVATE confirm to FE3 or FE7 as appropriate.
- 207 On receipt of the DEACTIVATE request from FE3 or FE7, FE2 shall perform the following actions:
- verify that the restricted users identity is within the jurisdiction of the authorized user;
  - deactivate SS-CAD dependent on the implementation option;
  - send a confirmation in DEACTIVATE confirm to FE3 or FE7 as appropriate.
- 208 On receipt of the DEFINE request from FE3, FE2 shall perform the following actions:
- verify that the restricted users identity is within the jurisdiction of the authorized user;
  - define SS-CAD for a restricted user dependent on the definition parameters;
  - send a confirmation in DEFINE confirm to FE3.
- 211 On receipt of the INTERROGATE request from FE3 or FE7, FE2 shall perform the following actions:
- verify that the restricted users identity is within the jurisdiction of the authorized user;
  - send a confirmation in INTERROGATE confirm to FE3 or FE7 as appropriate with the requested data.
- 212 On receipt of the ACTIVATE request from FE3 or FE7, FE2 shall perform the following actions:
- verify that the restricted users identity is within the jurisdiction of the dispatcher;
  - activate SS-CAD dependent on the implementation option;
  - send a confirmation in ACTIVATE confirm to FE3 or FE7 as appropriate.
- 213 On receipt of the DEACTIVATE request from FE3 or FE7, FE2 shall perform the following actions:
- verify that the restricted users identity is within the jurisdiction of the authorized user ;
  - deactivate SS-CAD dependent on the implementation option;
  - send a confirmation in DEACTIVATE confirm to FE3 or FE7 as appropriate.

214 On receipt of the INTERROGATE request from FE3 or FE7, FE2 shall perform the following actions:

- verify that the address of the restricted user is within the jurisdiction of that dispatcher;
- send a confirmation in INTERROGATE confirm to FE3 or FE7 as appropriate with the requested data.

215 At the end of the call with the dispatcher (i.e. when the latter sends the ACCEPT information flow), if the transmission permission grant has been changed compared to that defined in the original SETUP information flow, the contents of the SETUP information flow sent to user B SwMI FE2 shall be modified to reflect the current transmission permission grant.

Upon connection completion to user B, FE2 shall send the ISI-THROUGH CONNECT information flow to the originating FE2 if the call has been diverted to the dispatcher.

### 5.5.3 ISI FE actions of FE2

ISI functional entity actions of FE2 relay messages between FE2s of different SwMIs as described in ETS 300 392-3-1 [4] and ETS 300 392-9 [7].

401 On receipt of an information flow from FE3 or FE7 FE2 sends it to FE2 of the destination SwMI.

402 On receipt of an information flow from another SwMI FE2 sends it to FE1, FE3 or FE7 as appropriate.

### 5.5.4 FE actions of FE3

301 Receives activate request from the authorized user and sends the request further on to FE2 in ACTIVATE.

302 Receives ACTIVATE ACK from FE2 and sends the confirmation further on to the authorized user.

303 Receives deactivate request from the authorized user and sends the request further on to FE2 in DEACTIVATE.

304 Receives DEACTIVATE ACK from FE2 and sends the confirmation further on to the authorized user.

305 Receives definition request from the authorized user and sends the request further on to FE2 in DEFINE.

306 Receives DEFINE ACK from FE2 and sends the confirmation further on to the authorized user.

309 Receives interrogation request from the authorized user and sends the request further on to FE2 in INTERROGATE.

310 Receives INTERROGATE ACK from FE2 and sends the confirmation further on to the authorized user.

### 5.5.5 FE actions of FE7

701 Delivers notifications to the dispatcher received in REQUEST from FE2 regarding the interception.

702 Receives response from the dispatcher that the call has been authorized and accepted. The initial call set-up to user B shall continue. The response is sent in a ACCEPT to FE2.

703 Receives information from the dispatcher that the call from user A shall be redirected to the dispatcher for authorization. The information is sent back to FE2 in DIVERT.



- 704 Receives information from the dispatcher that the authorization of the call was not granted, and sends this information in REJECT to FE2.
- 705 Delivers notifications to the dispatcher received in CANCEL from FE2 that the calling user A has disconnected the call.
- 706 Receives activate request from the dispatcher and sends the request further on to FE2 in ACTIVATE.
- 707 Receives ACTIVATE ACK from FE2 and sends the confirmation further on to the dispatcher.
- 709 Receives deactivate request from the dispatcher and sends the request further on to FE2 in DEACTIVATE.
- 700 Receives DEACTIVATE ACK from FE2 and sends the confirmation further on to the dispatcher.
- 702 Receives interrogation request from the dispatcher and sends the request further on to FE2 in INTERROGATE.
- 703 Receives INTERROGATE ACK from FE2 and sends the confirmation further on to the dispatcher.

## 6 Allocation of FEs to physical equipment

FEs shall be allocated to physical equipment as defined in table 19.

**Table 19: Functional entities allocation to physical equipment**

Process	SwMI	MS/LS
Activation	FE2 (optional)	FE3 (optional)
Authorization	FE2 (mandatory)	FE7 (optional)
Definition	FE2 (optional)	FE3 (optional)
Interrogation	FE2 (optional)	FE3 (optional)
Operation	FE2 (mandatory)	-
User guidance	FE2 (optional)	FE1 (optional)

The CAD management comprises processes definition, activation and interrogation.

Implementations of CAD management and dispatcher operations connected by other means to SwMI are outside the scope of this ETS.

## 7 Inter-working considerations

Gateway identities identified by TETRA identities can be restricted identities. Restrictions against individual external network numbers can be applied, but a definition process of those numbers is outside the scope of this ETS.

### 7.1 Operation

The SS-CAD operation may extend to several TETRA networks. A visited SwMI may invoke and operate SS-CAD against a visited user using local or user's home SwMI restrictions or a combination of those.

The requirement that the affected user is to receive guidance information sets only the general call related supplementary service requirements to the SwMI which is not invoking or operating the SS-CAD. The general call related supplementary service requirements are defined in ETS 300 392-3-1 [4] and in ETS 300 392-9 [7].

A migrated dispatcher operating SS-CAD of another SwMI also sets only the same general requirements to the SwMI where the dispatcher has migrated. Refer to ETS 300 392-3-2 [5] for a basic call over ISI.

**7.2 Management**

The SS-CAD management may extend to several TETRA networks. In order to allow a visited users to perform definition, activation and interrogation the visited SwMI shall support general supplementary service information exchange mechanisms as defined in ETS 300 392-3-1 [4] and in ETS 300 392-9 [7]. Refer to clause 4.2.3 for information flow examples.

**7.3 Migration**

The visited SwMI may need a SS-CAD profile for the migrating user in order to locally invoke authorization as defined in the restricted user's home SwMI. Upon individual user migration the home SwMI may send user related SS-CAD profile to the visited SwMI and the visited SwMI may response with a modified temporary profile as presented in figure 23, refer to ETS 300 392-3-5 [6] for protocol definition.

The SS-ISI-PROFILE information flow shall contain SS-CAD specific information elements as defined in table 20.

**Table 20: Contents of SS-ISI-PROFILE**

Element	Type
Restricted user TETRA identity	M
Activation state	M
Intercepting dispatcher identity	O
Interception type	O
Basic service restrictions incoming calls	O
Basic service restrictions outgoing calls	O
Restricted source identity range	O
Restricted destination identity range	O
Restricted area list	O
NOTE: Refer to DEFINE information flow for element descriptions	

The SS-ISI-PROFILE ACK information flow shall contain information elements the visited SwMI has modified. The elements are the same as in the SS-ISI-PROFILE information flow.

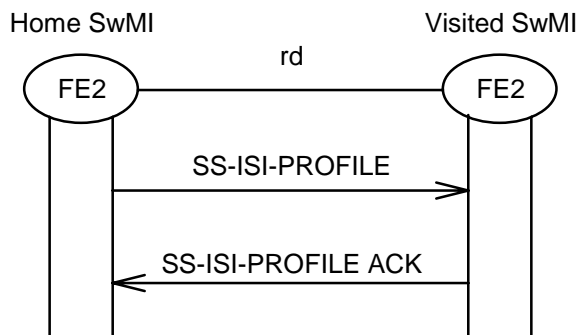

**Figure 23: Supplementary service profile exchange**

## History

Document history			
July 1996	Public Enquiry	PE 110:	1996-07-22 to 1996-11-15
August 1998	Vote	V 9841:	1998-08-11 to 1998-10-09