



EUROPEAN
TELECOMMUNICATION
STANDARD

ETS 300 392-4-2

August 2000

Source: TETRA

Reference: DE/TETRA-03001-04-2

ICS: 33.020

Key words: ISDN, radio, TETRA, V+D

**Terrestrial Trunked Radio (TETRA);
Voice plus Data (V+D);
Part 4: Gateways basic operation;
Sub-part 2: Integrated Services Digital Network (ISDN) gateway**

ETSI

European Telecommunications Standards Institute

ETSI Secretariat

Postal address: F-06921 Sophia Antipolis CEDEX - FRANCE

Office address: 650 Route des Lucioles - Sophia Antipolis - Valbonne - FRANCE

Internet: secretariat@etsi.fr - <http://www.etsi.org>

Tel.: +33 4 92 94 42 00 - Fax: +33 4 93 65 47 16

Copyright Notification: No part may be reproduced except as authorized by written permission. The copyright and the foregoing restriction extend to reproduction in all media.

© European Telecommunications Standards Institute 2000. All rights reserved.

Contents

Foreword.....	11
1 Scope	13
2 Normative references	14
3 Definitions and abbreviations	16
3.1 Definitions	16
3.2 Abbreviations	16
4 ISDN gateway stage 1 specification.....	17
4.1 Description.....	17
4.1.1 General description	17
4.1.2 Qualifications on applicability to telecommunication services.....	17
4.2 Procedures.....	17
4.2.1 Provision/withdrawal.....	17
4.2.2 Normal procedures.....	17
4.2.2.1 Activation/deactivation/registration/interrogation.....	17
4.2.2.2 Invocation and operation	18
4.2.2.2.1 Maintenance of the TETRA call.....	18
4.2.2.2.2 Termination of the TETRA call.....	18
4.2.3 Exceptional procedures.....	18
4.2.3.1 Activation/deactivation/registration/interrogation.....	18
4.2.3.2 Invocation and operation	18
4.3 Interaction with TETRA supplementary services.....	19
4.3.1 Calling Line Identification Presentation (SS-CLIP)	19
4.3.1.1 Incoming call set-up at ISDN gateway	19
4.3.1.2 Outgoing call set-up at ISDN gateway	19
4.3.1.3 Call maintenance phase	19
4.3.2 Connected Line Identification Presentation (SS-COLP)	19
4.3.2.1 Incoming call set-up at ISDN gateway	19
4.3.2.2 Outgoing call set-up at ISDN gateway	19
4.3.2.3 Call maintenance phase	20
4.3.3 Calling Line Identification Restriction (SS-CLIR)	20
4.3.3.1 Incoming call set-up at ISDN gateway	20
4.3.3.2 Outgoing call set-up at ISDN gateway	20
4.3.3.3 Call maintenance phase	20
4.3.4 Connected Line Identification Restriction(SS-COLR)	20
4.3.4.1 Incoming call set-up at ISDN gateway	20
4.3.4.2 Outgoing call set-up at ISDN gateway	20
4.3.4.3 Call maintenance phase	20
4.3.5 Call Report (SS-CR).....	20
4.3.5.1 Incoming call set-up at ISDN gateway	20
4.3.5.2 Outgoing call set-up at ISDN gateway	20
4.3.5.3 Call maintenance phase	21
4.3.6 Talking Party Identification (SS-TPI).....	21
4.3.6.1 Incoming call set-up at ISDN gateway	21
4.3.6.2 Outgoing call set-up at ISDN gateway	21
4.3.6.3 Call maintenance phase	21
4.3.7 Call Forwarding Unconditional (SS-CFU)	21
4.3.7.1 Incoming call set-up at ISDN gateway	21
4.3.7.2 Outgoing call set-up at ISDN gateway	21
4.3.7.2.1 ISDN subscriber number dialled:.....	21
4.3.7.2.2 TETRA identity dialled:	21
4.3.7.3 Call maintenance phase	21
4.3.8 Call Forwarding on Busy (SS-CFB)	22

	4.3.8.1	Incoming call set-up at ISDN gateway.....	22
	4.3.8.2	Outgoing call set-up at ISDN gateway.....	22
		4.3.8.2.1 ISDN subscriber number dialled	22
		4.3.8.2.2 TETRA identity dialled.....	22
	4.3.8.3	Call maintenance phase	22
4.3.9		Call Forwarding on No Reply (SS-CFNRy)	22
	4.3.9.1	Incoming call set-up at ISDN gateway.....	22
		4.3.9.1.1 Individual calls	22
		4.3.9.1.2 Group calls	22
	4.3.9.2	Outgoing call set-up at ISDN gateway.....	22
		4.3.9.2.1 ISDN subscriber number dialled	22
		4.3.9.2.2 TETRA identity dialled.....	22
	4.3.9.3	Call maintenance phase	23
4.3.10		Call Forwarding on Not Reachable (SS-CFNRc)	23
	4.3.10.1	Incoming call set-up at ISDN gateway.....	23
		4.3.10.1.1 Individual calls	23
		4.3.10.1.2 Group calls	23
	4.3.10.2	Outgoing call set-up at ISDN gateway.....	23
		4.3.10.2.1 ISDN subscriber number dialled	23
		4.3.10.2.2 TETRA identity dialled.....	23
	4.3.10.3	Call maintenance phase	23
4.3.11		List Search Call (SS-LSC)	23
	4.3.11.1	Incoming call set-up at ISDN gateway.....	23
	4.3.11.2	Outgoing call set-up at ISDN gateway.....	23
	4.3.11.3	Call maintenance phase	24
4.3.12		Call Authorized by Dispatcher (SS-CAD)	24
	4.3.12.1	Incoming call set-up at ISDN gateway.....	24
	4.3.12.2	Outgoing call set-up at ISDN gateway.....	24
	4.3.12.3	Call maintenance phase	24
4.3.13		Short Number Addressing (SS-SNA)	24
	4.3.13.1	Incoming call set-up at ISDN gateway.....	24
	4.3.13.2	Outgoing call set-up at ISDN gateway.....	24
	4.3.13.3	Call maintenance phase	24
4.3.14		Area Selection (SS-AS)	25
	4.3.14.1	Incoming call set-up at ISDN gateway.....	25
	4.3.14.2	Outgoing call set-up at ISDN gateway.....	25
	4.3.14.3	Call maintenance phase	25
4.3.15		Access Priority (SS-AP).....	25
	4.3.15.1	Incoming call set-up at ISDN gateway.....	25
	4.3.15.2	Outgoing call set-up at ISDN gateway.....	25
	4.3.15.3	Call maintenance phase	25
4.3.16		Priority Call (SS-PC).....	26
	4.3.16.1	Incoming call set-up at ISDN gateway.....	26
	4.3.16.2	Outgoing call set-up at ISDN gateway.....	26
	4.3.16.3	Call maintenance phase	26
4.3.17		Call Waiting (SS-CW)	26
	4.3.17.1	Incoming call set-up at ISDN gateway.....	26
	4.3.17.2	Outgoing call set-up at ISDN gateway.....	26
	4.3.17.3	Call maintenance phase	26
4.3.18		Call Hold (SS-HOLD).....	26
	4.3.18.1	Incoming call set-up at ISDN gateway.....	26
	4.3.18.2	Outgoing call set-up at ISDN gateway.....	27
	4.3.18.3	Call maintenance phase	27
4.3.19		Call Completion to Busy Subscriber (SS-CCBS)	27
	4.3.19.1	Incoming call set-up at ISDN gateway.....	27
	4.3.19.2	Outgoing call set-up at ISDN gateway.....	27
	4.3.19.3	Call maintenance phase	27
4.3.20		Late Entry (SS-LE).....	27
	4.3.20.1	Incoming call set-up at ISDN gateway.....	27
	4.3.20.2	Outgoing call set-up at ISDN gateway.....	27
	4.3.20.3	Call maintenance phase	27
4.3.21		Transfer of Control (SS-TC).....	27
	4.3.21.1	Incoming call set-up at ISDN gateway.....	27

	4.3.21.2	Outgoing call set-up at ISDN gateway	28
	4.3.21.3	Call maintenance phase	28
4.3.22		Pre-emptive Priority Call (SS-PPC).....	28
	4.3.22.1	Incoming call set-up at ISDN gateway	28
	4.3.22.2	Outgoing call set-up at ISDN gateway	28
	4.3.22.3	Call maintenance phase	28
4.3.23		Include Call (SS-IC).....	28
	4.3.23.1	Incoming call set-up at ISDN gateway	28
	4.3.23.2	Outgoing call set-up at ISDN gateway	28
	4.3.23.3	Call maintenance phase	29
4.3.24		Advice of Charge (SS-AoC)	29
	4.3.24.1	Incoming call set-up at ISDN gateway	29
	4.3.24.2	Outgoing call set-up at ISDN gateway	29
	4.3.24.3	Call maintenance phase	29
4.3.25		Barring of Outgoing Calls (SS-BOC).....	29
	4.3.25.1	Incoming call set-up at ISDN gateway	29
	4.3.25.2	Outgoing call set-up at ISDN gateway	29
	4.3.25.3	Call maintenance phase	29
4.3.26		Barring of Incoming Calls (SS-BIC).....	29
	4.3.26.1	Incoming call set-up at ISDN gateway	29
	4.3.26.2	Outgoing call set-up at ISDN gateway	29
	4.3.26.3	Call maintenance phase	30
4.3.27		Discreet Listening (SS-DL).....	30
	4.3.27.1	Incoming call set-up at ISDN gateway	30
	4.3.27.2	Outgoing call set-up at ISDN gateway	30
	4.3.27.3	Call maintenance phase	30
4.3.28		Ambience Listening (SS-AL)	30
4.3.29		Dynamic Group Number Assignment (SS-DGNA).....	30
	4.3.29.1	Incoming call set-up at ISDN gateway	30
	4.3.29.2	Outgoing call set-up at ISDN gateway	30
	4.3.29.3	Call maintenance phase	30
4.3.30		Call Completion on No Reply (SS-CCNR)	31
	4.3.30.1	Incoming call set-up at ISDN gateway	31
	4.3.30.2	Outgoing call set-up at ISDN gateway	31
	4.3.30.3	Call maintenance phase	31
4.3.31		Call Retention (SS-CRT)	31
	4.3.31.1	Incoming call set-up at ISDN gateway	31
	4.3.31.2	Outgoing call set-up at ISDN gateway	31
	4.3.31.3	Call maintenance phase	31
4.4		Interactions with ISDN supplementary services	31
	4.4.1	Three-Party (3PTY)	31
	4.4.1.1	Incoming call set-up at ISDN gateway	31
	4.4.1.2	Outgoing call set-up at ISDN gateway	32
	4.4.1.3	Call maintenance phase	32
	4.4.2	Advice of Charge (SS-AoC)	32
	4.4.3	Call Completion to Busy Subscriber (CCBS)	32
	4.4.3.1	Incoming call set-up at ISDN gateway	32
	4.4.3.2	Outgoing call set-up at ISDN gateway	32
	4.4.3.3	Call maintenance phase	32
	4.4.4	Call Completion on No Reply (CCNR)	32
	4.4.4.1	Incoming call set-up at ISDN gateway	32
	4.4.4.2	Outgoing call set-up at ISDN gateway	33
	4.4.4.3	Call maintenance phase	33
	4.4.5	Call Deflection (CD).....	33
	4.4.5.1	Incoming call set-up at ISDN gateway	33
	4.4.5.2	Outgoing call set-up at ISDN gateway	33
	4.4.5.3	Call maintenance phase	33
	4.4.6	Call Forwarding Busy (CFB)	33
	4.4.6.1	Incoming call set-up at ISDN gateway	33
	4.4.6.2	Outgoing call set-up at ISDN gateway	33
	4.4.6.3	Call maintenance phase	33
	4.4.7	Call Forwarding on No Reply (CFNR).....	33
	4.4.7.1	Incoming call set-up at ISDN gateway	33

4.4.7.2	Outgoing call set-up at ISDN gateway	34
4.4.8	Call Forwarding Unconditional (CFU)	34
4.4.8.1	Incoming call set-up at ISDN gateway	34
4.4.8.2	Outgoing call set-up at ISDN gateway	34
4.4.8.3	Call maintenance phase	34
4.4.9	Calling Line Identification Presentation (CLIP)	34
4.4.9.1	Incoming call set-up at ISDN gateway	34
4.4.9.2	Outgoing call set-up at ISDN gateway	34
4.4.9.3	Call maintenance phase	35
4.4.10	Calling Line Identification Restriction (CLIR)	35
4.4.10.1	Incoming call set-up at ISDN gateway	35
4.4.10.2	Outgoing call set-up at ISDN gateway	35
4.4.10.3	Call maintenance phase	35
4.4.11	Connected Line Identification Presentation (COLP)	35
4.4.11.1	Incoming call set-up at ISDN gateway	35
4.4.11.2	Outgoing call set-up at ISDN gateway	36
4.4.11.3	Call maintenance phase	36
4.4.12	Connected Line Identification Restriction (COLR)	36
4.4.12.1	Incoming call set-up at ISDN gateway	36
4.4.12.2	Outgoing call set-up at ISDN gateway	36
4.4.12.3	Call maintenance phase	36
4.4.13	Conference call, add on (CONF)	36
4.4.13.1	Incoming call set-up at ISDN gateway	36
4.4.13.2	Outgoing call set-up at ISDN gateway	36
4.4.13.3	Call maintenance phase	36
4.4.14	Closed User Group (CUG)	37
4.4.15	Call Waiting (CW)	37
4.4.15.1	Incoming call set-up at ISDN gateway	37
4.4.15.2	Outgoing call set-up at ISDN gateway	37
4.4.15.3	Call maintenance phase	37
4.4.16	Direct Dial In (DDI)	37
4.4.16.1	Incoming call set-up at ISDN gateway	37
4.4.16.2	Outgoing call set-up at ISDN gateway	37
4.4.16.3	Call maintenance phase	37
4.4.17	Explicit Call Transfer (ECT)	38
4.4.18	Freephone (FPH)	38
4.4.18.1	Incoming call set-up at ISDN gateway	38
4.4.18.2	Outgoing call set-up at ISDN gateway	38
4.4.18.3	Call maintenance phase	38
4.4.19	Call Hold (HOLD)	38
4.4.19.1	Incoming call set-up at ISDN gateway	38
4.4.19.2	Outgoing call set-up at ISDN gateway	38
4.4.19.3	Call maintenance phase	38
4.4.20	Malicious Call Identification (MCID)	39
4.4.21	Multiple Subscriber Number (MSN)	39
4.4.21.1	Incoming call set-up at ISDN gateway	39
4.4.21.2	Outgoing call set-up at ISDN gateway	39
4.4.21.3	Call maintenance phase	39
4.4.22	Message Waiting Indication (MWI)	39
4.4.23	Outgoing Call Barring (OCB)	39
4.4.23.1	Incoming call set-up at ISDN gateway	39
4.4.23.2	Outgoing call set-up at ISDN gateway	39
4.4.23.3	Call maintenance phase	39
4.4.24	Subaddressing (SUB)	40
4.4.24.1	Incoming call set-up at ISDN gateway	40
4.4.24.2	Outgoing call set-up at ISDN gateway	40
4.4.24.3	Call maintenance phase	40
4.4.25	Terminal Portability (TP)	40
4.4.25.1	Incoming call set-up at ISDN gateway	40
4.4.25.2	Outgoing call set-up at ISDN gateway	40
4.4.25.3	Call maintenance phase	40
4.4.26	User-to-User signalling (UUS)	40
4.4.26.1	Incoming call set-up at ISDN gateway	40

	4.4.26.2	Outgoing call set-up at ISDN gateway	40
	4.4.26.3	Call maintenance phase	40
4.5		Interworking considerations	40
4.6		ISDN gateway service description	41
	4.6.1	ISDN gateway service	41
	4.6.1.1	ISDN gateway primitives exchanged through the ISDNCC-SAP	41
	4.6.1.2	Service primitives at the ISDNCC-SAP	41
	4.6.1.3	Service primitive description	42
	4.6.1.3.1	ISDNCC-ALERTING primitive	42
	4.6.1.3.2	ISDNCC-COMPLETE primitive	42
	4.6.1.3.3	ISDNCC-RELEASE primitive	42
	4.6.1.3.4	ISDNCC-SETUP primitive	43
	4.6.1.3.5	ISDNCC-TX primitive	43
	4.6.1.4	Parameter descriptions	44
	4.6.1.5	Overall SDL	45
	4.6.1.6	Static description of ISDN gateway attributes	49
5		TETRA gateway stage 2 specification	50
	5.1	Functional model	50
	5.1.1	Functional model description	50
	5.1.2	Description of functional entities	51
	5.1.2.1	SwMI call control application functional entity, FE1	51
	5.1.2.2	ISDN interface functional entity, FE2	51
	5.1.2.3	ISDN network, FE3	51
	5.2	Information flow	51
	5.2.1	Information flow diagrams	51
	5.2.1.1	Successful call set-up to an ISDN subscriber	52
	5.2.1.2	Successful call set-up from an ISDN subscriber over the ISDN gateway	54
	5.2.1.3	Call set-up request from an ISDN subscriber queued	57
	5.2.1.4	Unsuccessful call set-up to an ISDN subscriber	58
	5.2.1.5	Unsuccessful call set-up from an ISDN subscriber	60
	5.2.1.6	Unsuccessful call set-up, B-channel not accepted	62
	5.2.1.7	Call maintenance procedures - Transmission control towards an ISDN subscriber	63
	5.2.1.8	Call maintenance procedures - Interrupt of transmitting ISDN subscriber	64
	5.2.1.9	Call maintenance procedures - Withdrawal of transmission in the gateway SwMI	64
	5.2.1.10	Call disconnection procedures - Request to disconnect from a TETRA user or TETRA SwMI	65
	5.2.1.11	Call disconnection procedures - Request to disconnect from the ISDN network	66
	5.3	Functional Entity Actions (FEAs)	66
	5.3.1	Functional entity actions of FE2	66
6		ISDN gateway stage 3 specification	68
	6.1	Protocol structure and protocol stack	68
	6.2	TETRA gateway coding requirements	68
	6.2.1	Non end-to-end ISDN calls	69
	6.2.1.1	Alert tone	69
	6.2.1.2	Busy tone	69
	6.2.1.3	Disconnect tone	69
	6.2.1.4	Invalid number tone	69
	6.2.2	Two stage dialling	69
	6.2.2.1	Dialling Tone	69
	6.2.2.2	Dialling	69
	6.2.2.3	Call set-up tones sent in-band	69
	6.2.3	Call set-up queuing	70
	6.2.3.1	TETRA queuing tone	70
	6.2.4	Transmission signalling	70
	6.2.4.1	User-to-User Signalling	70

6.2.4.2	DTMF signalling	70
6.2.4.3	Guidance tones	70
6.2.4.3.1	TX-ceased tone	70
6.2.4.3.2	TX-granted tone	70
6.2.4.3.3	TX-interrupt tone	70
6.2.5	DTMF signalling during ACTIVE state	71
6.2.5.1	From ISDN network	71
6.2.5.2	From TETRA network	71
6.3	TETRA gateway state definitions	71
6.4	TETRA gateway signalling procedures	71
6.4.1	Call set-up procedures	71
6.4.1.1	Incoming calls	71
6.4.1.1.1	Two stage dialling	72
6.4.1.1.2	Acknowledged group calls	72
6.4.1.1.3	Broadcast calls	72
6.4.1.1.4	Call priority	72
6.4.1.2	Outgoing calls	72
6.4.1.2.1	Two stage dialling	72
6.4.1.2.2	Acknowledged group calls	73
6.4.1.2.3	Broadcast calls	73
6.4.1.3	Colliding calls	73
6.4.1.4	Unsuccessful call set-up	73
6.4.2	Call maintenance procedures	73
6.4.2.1	Transmission request	74
6.4.2.1.1	Voice activity detection	74
6.4.2.1.2	User-to-user signalling	74
6.4.2.1.3	DTMF signalling	75
6.4.2.2	Transmission request response	75
6.4.2.2.1	Voice activity detection	75
6.4.2.2.2	User-to-user signalling	75
6.4.2.2.3	DTMF signalling	75
6.4.2.3	End of transmission	76
6.4.2.3.1	Voice activity detection	76
6.4.2.3.2	User-to-user signalling	76
6.4.2.3.3	DTMF signalling	76
6.4.2.4	Interruption of transmission	76
6.4.2.4.1	Voice activity detection	76
6.4.2.4.2	User-to-user signalling	76
6.4.2.4.3	DTMF signalling	76
6.4.3	Call disconnection procedures	77
6.4.3.1	Disconnect initiated by TETRA user or TETRA SwMI	77
6.4.3.2	Disconnection initiated by ISDN subscriber	77
6.4.3.3	Colliding disconnection	77
6.5	Protocol interaction between TETRA gateway and TETRA supplementary services	77
6.6	Protocol interaction between TETRA gateway and ISDN supplementary services	77
6.7	TETRA gateway parameter values (timers)	77
Annex A (normative): Specification and description Language (SDL) representation of procedures ..		78
A.1	SDL representation of ISDN interface entity FE2	78
Annex B (normative): TETRA group call set-up with external ISDN group members		85
B.1	User-to-user signalling service 3	85
B.1.1	Functional Entity Actions (FEAs)	88
B.1.1.1	Functional entity actions of FE2	88
Annex C (informative): Static description of the TETRA ISDN gateway bearer service, using attributes		89
C.1	Information transfer attributes	89
C.2	Access attributes	89

Annex D (informative):	Mapping of TETRA disconnection causes to ISDN disconnection causes	90
D.1	Mapping of TETRA disconnect causes	90
Annex E (informative):	TETRA supplementary services	93
E.1	TETRA supplementary services - SCCF	93
Annex F (informative):	Bibliography	94
History	95

Blank page

Foreword

This European Telecommunication Standard (ETS) has been produced by the Terrestrial Trunked Radio (TETRA) ETSI Project of the European Telecommunications Standards Institute (ETSI).

This ETS consists of 14 parts as follows:

- Part 1: "General network design";
- Part 2: "Air Interface (AI)";
- Part 3: "Interworking at the Inter-System Interface (ISI)";
- Part 4: "Gateways basic operation";**
- Part 5: "Peripheral Equipment Interface (PEI)";
- Part 6: "Line connected Station (LS)";
- Part 7: "Security";
- Part 9: "General requirements for supplementary services";
- Part 10: "Supplementary services stage 1";
- Part 11: "Supplementary services stage 2";
- Part 12: "Supplementary services stage 3";
- Part 13: "SDL model of the Air Interface (AI)";
- Part 14: "Protocol Implementation Conformance Statement (PICS) proforma specification".

Transposition dates	
Date of adoption of this ETS:	7 July 2000
Date of latest announcement of this ETS (doa):	31 October 2000
Date of latest publication of new National Standard or endorsement of this ETS (dop/e):	30 April 2001
Date of withdrawal of any conflicting National Standard (dow):	30 April 2001

Blank page

1 Scope

This ETS defines the Terrestrial Trunked Radio (TETRA) system supporting Voice plus Data (V+D). In accordance with ITU-T Recommendations I.130 [28], the stage one, stage two and stage three of the three level structure is used to specify the TETRA gateway to Public Integrated Services Digital Network (ISDN):

- Stage 1, is an overall service description, from the service subscriber's and user's standpoint;
- Stage 2, identifies the functional capabilities and information flows needed to support the services described in stage 1, and

NOTE 1: The information flows in stage 2 have been drawn as Message Sequence Charts (MSCs).

- Stage 3, defines the signalling system protocols and switching functions needed to implement the services described in stage 1.

Specifically this standard details the stage 1 aspects (overall service description) of the TETRA gateway as seen from the TETRA Switching and Maintenance Infrastructure point of view at the T reference point or coincident S and T reference points for the ISDN subscriber.

NOTE 2: This standard is applicable at the T and S references. It should however be noted, that no standards exist for the S reference point.

It details the stage 2 aspects (functional partitioning) of the TETRA gateway which includes the identification of the functional entities and the flows between them and finally it details the stage 3 signalling protocols for the TETRA gateway services, i.e. the protocol at the relevant reference points between the functional entities defined in stage 2. The described network layer services and protocols apply for the Switching and Management Infrastructure (SwMI), for the TETRA gateway and to the keypad protocol for the ISDN subscriber using TETRA services.

A basic call is initiated at the TETRA gateway when, a SwMI detects an incoming call from an ISDN subscriber to a TETRA user or an outgoing call is made from a TETRA user to an ISDN subscriber. The TETRA gateway ensures that basic signalling required in the operation of the TETRA call and the ISDN call is maintained across the gateway.

The TETRA gateway and the TETRA system are seen by the external network as if it were a subscriber (users side) of the external network. For incoming calls from ISDN three methods of addressing a TETRA user are applicable, Subaddressing (SUB), Direct Dial In (DDI) and two stage dialing. Other means of incoming calls using other than ISDN subscriber lines, between the TETRA system and the external network exchange are outside the scope of this ETS.

End to end encryption is outside the scope of this ETS.

This ETS describes the TETRA gateway function, which provides an ISDN interface to the SwMI. Primary and basic rate is supported. However, multiple gateways on the same basic rate bus are not supported.

Circuit mode data calls are outside the scope of this ETS.

2 Normative references

This European Telecommunications Standard (ETS) incorporates by dated and undated reference, provisions from other publications. These normative references are cited at the appropriate places in the text and the publications are listed hereafter. For dated references, subsequent amendments to or revisions of any of these publications apply to this European Telecommunications Standard only when incorporated in it by amendment or revision. For undated references the latest edition of the publication referred to apply.

- [1] ETSI EN 300 058-1: "Integrated Services Digital Network (ISDN); Call Waiting (CW) supplementary service; Digital Subscriber Signalling System No. one (DSS1) protocol; Part 1: Protocol specification".
- [2] ETSI EN 301 065-1: "Integrated Services Digital Network (ISDN); Completion of Calls on No Reply (CCNR) supplementary service; Digital Subscriber Signalling System No. one (DSS1) protocol; Part 1: Protocol specification".
- [3] ETSI EN 300 092-1: "Integrated Services Digital Network (ISDN); Calling Line Identification Presentation (CLIP) supplementary service; Digital Subscriber Signalling System No. one (DSS1) protocol; Part 1: Protocol specification".
- [4] ETSI EN 300 097-1: "Integrated Services Digital Network (ISDN); Connected Line Identification Presentation (COLP) supplementary service; Digital Subscriber Signalling System No. one (DSS1) protocol; Part 1: Protocol specification".
- [5] ETSI EN 300 141-1: "Integrated Services Digital Network (ISDN); Call hold (HOLD) supplementary service; Digital Subscriber Signalling System No. one (DSS1) protocol; Part 1: Protocol specification".
- [6] ETSI EN 300 207-1: "Integrated Services Digital Network (ISDN); Diversion supplementary services; Digital Subscriber Signalling System No. one (DSS1) protocol; Part 1: Protocol specification".
- [7] ETSI EN 300 286-1: "Integrated Services Digital Network (ISDN); User-to-User Signalling (UUS) supplementary service; Digital Subscriber Signalling System No. one (DSS1) protocol; Part 1: Protocol specification".
- [8] ETSI EN 300 359-1: "Integrated Services Digital Network (ISDN); Completion of Calls to Busy Subscriber (CCBS) supplementary service; Digital Subscriber Signalling System No. one (DSS1) protocol; Part 1: Protocol specification".
- [9] ETSI EN 300 403-1: "Integrated Services Digital Network (ISDN); Digital Subscriber Signalling System No. one (DSS1) protocol; Signalling network layer for circuit-mode basic call control; Part 1: Protocol specification [ITU-T Recommendation Q.931 (1993), modified]".
- [10] ETSI ETS 300 085: "Integrated Services Digital Network (ISDN); 3,1 kHz telephony teleservice; Attachment requirements for handset terminals (Candidate NET 33)".
- [11] ETSI ETS 300 392-1: "Terrestrial Trunked Radio (TETRA); Voice plus Data (V+D); Part 1: General network design".
- [12] ETSI ETS 300 392-2: "Terrestrial Trunked Radio (TETRA); Voice plus Data (V+D); Part 2: Air Interface (AI)".
- [13] ETSI ETS 300 392-3: "Terrestrial Trunked Radio (TETRA); Voice plus Data (V+D); Part 3: Interworking at the Inter-System Interface (ISI); Sub-part 1: General design".

- [14] ETSI ETS 300 392-4-1: "Terrestrial Trunked Radio (TETRA); Voice plus Data (V+D); Part 4: Gateways basic operation; Sub-part 1: Public Switched Telephone Network (PSTN)".
- [15] ETSI ETS 300 392-9: "Terrestrial Trunked Radio (TETRA); Voice plus Data (V+D); Part 9: General requirements for supplementary services".
- [16] ETSI ETS 300 392-12-3: "Terrestrial Trunked Radio (TETRA); Voice plus Data (V+D); Part 12: Supplementary services stage 3; Sub-part 3: Talking Party Identification (TPI)".
- [17] ETSI ETS 300 392-12-4: "Terrestrial Trunked Radio (TETRA); Voice plus Data (V+D); Part 12: Supplementary services stage 3; Sub-part 4: Call Forwarding (CF)".
- [18] ETSI ETS 300 392-12-8: "Terrestrial Trunked Radio (TETRA); Voice plus Data (V+D); Part 12: Supplementary services stage 3; Sub-part 8: Area Selection (AS)".
- [19] ETSI ETS 300 392-12-10: "Terrestrial Trunked Radio (TETRA); Voice plus Data (V+D); Part 12: Supplementary services stage 3; Sub-part 10: Priority Call (PC)".
- [20] ETSI ETS 300 392-12-13: "Terrestrial Trunked Radio (TETRA); Voice plus Data (V+D); Part 12: Supplementary services stage 3; Sub-part 13: Call Completion to Busy Subscriber (CCBS)".
- [21] ETSI ETS 300 392-12-16: "Terrestrial Trunked Radio (TETRA); Voice plus Data (V+D); Part 12: Supplementary services stage 3; Sub-part 16: Pre-emptive Priority Call (PPC)".
- [22] ETSI ETS 300 392-12-23: "Terrestrial Trunked Radio (TETRA); Voice plus Data (V+D); Part 12: Supplementary services stage 3; Sub-part 23: Call Completion on No Reply (CCNR)".
- [23] ETSI ETS 300 738: "Human Factors (HF); Minimum Man-Machine Interface (MMI) to public network based supplementary services".
- [24] ETSI ETR 300-5: "Terrestrial Trunked Radio (TETRA); Voice plus Data (V+D); Designers' guide; Part 5: Guidance on Numbering and addressing".
- [25] ETSI I-ETS 300 245-1: "Integrated Services Digital Network (ISDN); Technical characteristics of telephony terminals; Part 1: General".
- [26] ITU-T Recommendation G.711 (1988): "Pulse code modulation (PCM) of voice frequencies".
- [27] ITU-T Recommendation I.112 (1993): "Vocabulary of terms for ISDNs".
- [28] ITU-T Recommendation I.130 (1988): "Method for the characterization of telecommunication services supported by an ISDN and network capabilities of an ISDN".
- [29] ITU-T Recommendation I.140 (1993): "Attribute technique for the characterization of telecommunication services supported by an ISDN and network capabilities of an ISDN".
- [30] ITU-T Recommendation I.210 (1993): "Principles of telecommunication services supported by an ISDN and the means to describe them".
- [31] ITU-T Recommendation Z.100 (1993): "CCITT Specification and description language (SDL)".

3 Definitions and abbreviations

3.1 Definitions

For the purposes of this ETS the following terms and definitions apply:

B-channel: 64 kbit/s channel accompanied by timing intended to carry a wide variety of user information streams, i.e. voice, image or data transmission. A B-channel does not carry signalling information for circuit switching by the ISDN.

D-channel: channel primarily intended to carry signalling information for circuit switching by the ISDN, i.e. call establishment, call monitoring, call termination and enhanced telephone feature information. Out-of band signalling.

DDI number: ISDN number or part of an ISDN number which is delivered to the TETRA gateway. It can be the subscriber, national or international number or a partial number. The DDI number is defined to be at least that part of the ISDN number which is significant to the TETRA network.

en bloc receiving: procedure, used in call establishment of an incoming call, to enable the ISDN network to send called party number digits to the TETRA network in a single message.

in-band signalling: main traffic bearer is used for signalling, data and telemetry information, i.e. B-channel. A signalling method in which signals are sent over the same transmission or circuit channel as the user's communication, in the same frequency band as that provided for the user.

incoming call: call from the ISDN to the TETRA network.

Integrated Services Digital Network (ISDN): see ITU-T Recommendation I.112 [27], definition 308.

originating SwMI: SwMI from where the call originates, i.e. where the initial call set-up is detected.

outgoing call: call from a TETRA network to the ISDN.

overlap receiving: procedure, used in call establishment of an incoming call, to enable the ISDN network to send called party number digits to the TETRA network in successive messages, as and when they are made available from the ISDN network.

participating SwMI: SwMI only participates in a group call without controlling it and will always be the end point of the call.

S reference: conceptual point at the conjunction of the TE1 (terminal equipment type 1) and NT2 (network termination type 2) functional groups.

S/T reference: conceptual point at the conjunction of the TE1 and NT1 functional group when the NT2 functional group is null.

T reference: conceptual point at the conjunction of the NT1 and NT2 functional groups.

3.2 Abbreviations

For the purposes of this ETS the following abbreviations apply:

3PTY	Three-Party
CC	Call Control (PISN functional entity)
CD	Call Deflection
CONF	Conference call, add on
CUG	Closed User Group
CW	Call Waiting
DDI	Direct Dial In
DSS1	Digital Subscriber Signalling System Number 1
ECT	Explicit Call Transfer
FE	Functional Entity

FPH	Freephone
GTSI	Group TETRA Subscriber Identity
IA5	International Alphabet No.5
ISDN	Integrated Services Digital Network
ITSI	Individual TETRA Subscriber Identity
MCID	Malicious Call Identification
MSN	Multiple Subscriber Number
MWI	Message Waiting Indication
OCB	Outgoing Call Barring
PINX	Private Integrated Services Network Exchange
PISN	Private Integrated Services Network
SDL	Specification and Description Language
SUB	Subaddressing
SwMI	Switching and Management Infrastructure
TP	Terminal Portability
UUS	User-to-User signalling

4 ISDN gateway stage 1 specification

4.1 Description

4.1.1 General description

The ISDN gateway enables calls to be set-up from an ISDN subscriber to a TETRA user and a TETRA user to an ISDN subscriber. Additionally, for the duration of the call, the ISDN gateway allows ISDN signalling information to be passed from the external network to the TETRA Switching and Management Infrastructure (SwMI) in accordance with the TETRA Call Control (CC) procedures as defined in ETS 300 392-2 [12] and TETRA signalling information to be passed from the TETRA SwMI to the external network in accordance with the ISDN DSS1 Call Control (CC) procedures as defined in EN 300 403-1 [9].

The principles defined in this ETS can be used for interfacing with other networks such as private digital networks, e.g. Private Integrated Services Network Exchange (PINX).

4.1.2 Qualifications on applicability to telecommunication services

The ISDN gateway shall be applicable to clear mode point-to-point and point-to-multipoint circuit mode teleservices used for speech as defined in ETS 300 392-1 [11]. End to end encryption could be supported between a TETRA user and the ISDN gateway, but all provisions are outside the scope of this ETS.

4.2 Procedures

4.2.1 Provision/withdrawal

The ISDN gateway service shall be provided by prior arrangement with the service provider or they may be generally available.

This service may be withdrawn by the service provider at any time without a prior indication.

4.2.2 Normal procedures

4.2.2.1 Activation/deactivation/registration/interrogation

The ISDN gateway shall be permanently activated upon provision.

Registration and interrogation are not applicable.

4.2.2.2 Invocation and operation

The ISDN gateway shall be invoked either when a call request (incoming call) is received by the gateway from the ISDN network or when a call request has been received to an ISDN subscriber (outgoing call) by the SwMI.

NOTE: See ETR 300-5 [24] for TETRA dialling and addressing methods.

In the outgoing call case the ISDN gateway shall route the call to the ISDN network using the information found in the external subscriber number information elements. The ISDN gateway shall dial the external network number using appropriate signalling mechanisms defined for that network (see EN 300 403-1 [9] or relevant national requirements not covered by these standards).

In the incoming call case the ISDN gateway shall forward the called TETRA user identity to the SwMI CC entity for the call set-up completion. The called TETRA user shall be addressed either by the ISDN Direct Dial In (DDI) supplementary service, by the ISDN Subaddressing (SUB) supplementary service or by using two stage dialing mechanisms. DDI allows the external subscriber to directly dial a TETRA user or group of users, while subaddressing allows the called TETRA user or group of users to be identified by the subaddress information element in the ISDN SETUP message. Two stage dialing shall be applicable when separate ISDN numbers are not required for each individual TETRA user or group and when the ISDN supplementary service SUB is not supported by the calling ISDN subscriber.

The ISDN gateway shall remain operational for the duration of the call. The ISDN gateway shall send and receive TETRA signalling messages as appropriate under direction from the SwMI.

4.2.2.2.1 Maintenance of the TETRA call

An ISDN gateway supporting semi-duplex calls may inform the ISDN subscriber about the state of the call and may either receive explicit request to transmit and cease of transmission from the external network user or a voice activity detection mechanism for requests to transmit may be used. The exact mechanisms for voice detection, and its algorithms and how the result is used for the request to transmit are outside the scope of this ETS.

4.2.2.2.2 Termination of the TETRA call

All disconnection request received from the ISDN network shall be forwarded to the controlling or other end call control application for the call.

All disconnection request received from the controlling or other end call control application shall be forwarded to the ISDN network.

4.2.3 Exceptional procedures

4.2.3.1 Activation/deactivation/registration/interrogation

Not applicable.

4.2.3.2 Invocation and operation

The ISDN gateway may reject an incoming call request with an appropriate failure indication, e.g. for any of the following reasons:

- no destination number provided;
- B channel unacceptable, unavailable or invalid;
- bearer capability not valid;
- service or option not available;
- the called user address is incorrect;
- invalid call reference;
- invalid message.

See also EN 300 403-1 [9].

The ISDN gateway may reject an outgoing call request with an appropriate failure indication for any of the following reasons:

- no destination number provided;
- bearer capability not valid;
- service or option not available;
- the called user address is incorrect.

In addition, normal ISDN rejection and all restrictions and exceptional procedures for TETRA basic call establishment shall apply.

4.3 Interaction with TETRA supplementary services

Interactions with TETRA supplementary services for which TETRA Standards or TETRA draft standards were available at the time of publication of this Standard are specified below. The following interactions are defined for each TETRA supplementary service:

- incoming call set-up at ISDN gateway;
- outgoing call set-up at ISDN gateway;
- call maintenance phase.

This subclause defines how and when a TETRA supplementary service will interact with the ISDN gateway and ISDN network when this service has been invoked for a TETRA user.

4.3.1 Calling Line Identification Presentation (SS-CLIP)

4.3.1.1 Incoming call set-up at ISDN gateway

No interaction.

The calling party number is part of the basic call set-up signalling where available. Therefore, no further information is required from the ISDN network.

NOTE: Calling party subaddressing is not covered by this ETS.

4.3.1.2 Outgoing call set-up at ISDN gateway

Not applicable.

TETRA SS-CLIP is only invoked at a TETRA called user upon reception of an incoming set-up request.

4.3.1.3 Call maintenance phase

Not applicable.

TETRA SS-CLIP is only invoked during call set-up.

4.3.2 Connected Line Identification Presentation (SS-COLP)

4.3.2.1 Incoming call set-up at ISDN gateway

Not applicable.

TETRA SS-COLP is invoked at a TETRA calling user upon reception of a connect indication.

4.3.2.2 Outgoing call set-up at ISDN gateway

No interaction.

The connected party number is part of the basic call set-up signalling. Therefore, no further information is required from the ISDN network.

4.3.2.3 Call maintenance phase

Not applicable.

TETRA SS-COLP is only invoked during call set-up.

4.3.3 Calling Line Identification Restriction (SS-CLIR)

4.3.3.1 Incoming call set-up at ISDN gateway

Not applicable.

TETRA SS-CLIR is invoked at a TETRA calling user when calling line identification restriction is applicable.

4.3.3.2 Outgoing call set-up at ISDN gateway

No interaction.

The presentation restriction indication is defined as part of the calling party number information element sent during basic call set-up to an ISDN subscriber.

4.3.3.3 Call maintenance phase

When TETRA SS-CLIR has been invoked for a TETRA talking/sending party, its identity shall not be included in transmission messages sent to the ISDN subscriber.

4.3.4 Connected Line Identification Restriction(SS-COLR)

4.3.4.1 Incoming call set-up at ISDN gateway

No interaction.

The presentation restriction indication is defined as part of the connected number information element sent during basic call set-up to an ISDN subscriber.

NOTE: See EN 300 097-1 [4] for the definition of the information element connected number.

4.3.4.2 Outgoing call set-up at ISDN gateway

Not applicable.

TETRA SS-COLR is invoked at a TETRA called user upon reception of a call set-up request.

4.3.4.3 Call maintenance phase

Not applicable.

4.3.5 Call Report (SS-CR)

4.3.5.1 Incoming call set-up at ISDN gateway

Not applicable.

TETRA SS-CR is only offered to a calling user.

4.3.5.2 Outgoing call set-up at ISDN gateway

Not applicable.

No similar supplementary service exist for ISDN DSS1. It is therefore not possible to send TETRA SS-CR information to the called ISDN subscriber.

4.3.5.3 Call maintenance phase

Not applicable.

TETRA SS-CR is only applicable during call set-up.

4.3.6 Talking Party Identification (SS-TPI)

4.3.6.1 Incoming call set-up at ISDN gateway

No Interaction.

The ISDN gateway may provide the ISDN subscriber mnemonic name to the call control application if available as defined in ETS 300 392-12-3 [16].

4.3.6.2 Outgoing call set-up at ISDN gateway

Not applicable.

No similar supplementary service exist for ISDN DSS1. It is therefore not possible to send TETRA subscriber mnemonic names to the called ISDN subscriber using standardized mechanisms.

4.3.6.3 Call maintenance phase

Not applicable.

No similar supplementary service exist for ISDN DSS1. It is therefore not possible to send TETRA subscriber mnemonic names to an ISDN subscriber using standardized mechanisms.

4.3.7 Call Forwarding Unconditional (SS-CFU)

4.3.7.1 Incoming call set-up at ISDN gateway

If TETRA SS-CFU is invoked for a called user or group the calling ISDN subscriber shall be informed of diversion as described in EN 300 207-1 [6] clause 10.

4.3.7.2 Outgoing call set-up at ISDN gateway

4.3.7.2.1 ISDN subscriber number dialled:

Not applicable.

TETRA SS-CFU is only invoked when TETRA SS-CFU has been subscribed to, for a called TETRA user.

4.3.7.2.2 TETRA identity dialled:

No interaction.

The call may be forwarded to an ISDN subscriber upon invocation of TETRA SS-CFU for a called TETRA user. The ISDN subscriber shall be informed that diversion has occurred in the facility information element of the SETUP message. See EN 300 207-1 [6], subclause 10.4.1.

4.3.7.3 Call maintenance phase

Not applicable.

TETRA SS-CFU is only applicable during call set-up.

4.3.8 Call Forwarding on Busy (SS-CFB)

4.3.8.1 Incoming call set-up at ISDN gateway

If TETRA SS-CFB is invoked for a called user or group the calling ISDN subscriber shall be informed of diversion as described in EN 300 207-1 [6] clause 10.

4.3.8.2 Outgoing call set-up at ISDN gateway

4.3.8.2.1 ISDN subscriber number dialled

Not applicable.

TETRA SS-CFB is only invoked when TETRA SS-CFB has been subscribed to, for a called TETRA user.

4.3.8.2.2 TETRA identity dialled

No interaction.

The call may be forwarded to an ISDN subscriber upon invocation of TETRA SS-CFB for a called TETRA user. The ISDN subscriber shall be informed that diversion has occurred in the facility information element of the SETUP message. See EN 300 207-1 [6], subclause 10.4.1.

4.3.8.3 Call maintenance phase

Not applicable.

TETRA SS-CFB is only applicable during call set-up.

4.3.9 Call Forwarding on No Reply (SS-CFNRy)

4.3.9.1 Incoming call set-up at ISDN gateway

4.3.9.1.1 Individual calls

If TETRA SS-CFNRy is invoked for a called user, the calling ISDN subscriber shall be informed of diversion as described in EN 300 207-1 [6] clause 10.

4.3.9.1.2 Group calls

Not applicable.

SS-CFNRy does not apply for group calls.

4.3.9.2 Outgoing call set-up at ISDN gateway

4.3.9.2.1 ISDN subscriber number dialled

Not applicable.

TETRA SS-CFNRy is only invoked when TETRA SS-CFNRy has been subscribed to, for a called TETRA user.

4.3.9.2.2 TETRA identity dialled

No interaction.

The call may be forwarded to an ISDN subscriber upon invocation of TETRA SS-CFNRy for a called TETRA user. The ISDN subscriber shall be informed that diversion has occurred in the facility information element of the SETUP message. See EN 300 207-1 [6], subclause 10.4.1.

NOTE: SS-CFNRy is not applicable for group calls.

4.3.9.3 Call maintenance phase

Not applicable.

TETRA SS-CFNRC is only applicable during call set-up.

4.3.10 Call Forwarding on Not Reachable (SS-CFNRC)

4.3.10.1 Incoming call set-up at ISDN gateway

4.3.10.1.1 Individual calls

If TETRA SS-CFNRC is invoked for a called user, the calling ISDN subscriber shall be informed of diversion as described in EN 300 207-1 [6] clause 10.

4.3.10.1.2 Group calls

Not applicable.

SS-CFNRC does not apply for group calls.

4.3.10.2 Outgoing call set-up at ISDN gateway

4.3.10.2.1 ISDN subscriber number dialled

Not applicable.

TETRA SS-CFNRC is only invoked when TETRA SS-CFNRC has been subscribed to, for a called TETRA user.

4.3.10.2.2 TETRA identity dialled

No interaction.

The call may be forwarded to an ISDN subscriber upon invocation of TETRA SS-CFNRC for a called TETRA user. The ISDN subscriber shall be informed that diversion has occurred in the facility information element of the SETUP message. See EN 300 207-1 [6], subclause 10.4.1.

NOTE: SS-CFNRC is not applicable for group calls.

4.3.10.3 Call maintenance phase

Not applicable.

TETRA SS-CFNRC is only applicable during call set-up.

4.3.11 List Search Call (SS-LSC)

4.3.11.1 Incoming call set-up at ISDN gateway

No interaction.

NOTE 1: The connected user shall be indicated in the ISDN CONNECT message.

NOTE 2: See EN 300 097-1 [4] for the definition of the information element connected number.

4.3.11.2 Outgoing call set-up at ISDN gateway

No interaction.

External ISDN subscriber number may be included in the SS-LSC list of attendants.

4.3.11.3 Call maintenance phase

Not applicable.

TETRA SS-LSC is only applicable during call set-up.

4.3.12 Call Authorized by Dispatcher (SS-CAD)

4.3.12.1 Incoming call set-up at ISDN gateway

Not applicable.

An ISDN subscriber shall not be informed of CAD interaction when CAD has been invoked for a called TETRA user or group. Normal ISDN call set-up shall apply in this case. ISDN call set-up is not covered by this ETS.

If the call is diverted to a dispatcher the ISDN subscriber may be informed of the connected user in the ISDN CONNECT message.

NOTE: See EN 300 097-1 [4] for the definition of the information element connected number.

4.3.12.2 Outgoing call set-up at ISDN gateway

No interaction.

An outgoing call may be intercepted or diverted due to TETRA SS-CAD invocation before the ISDN gateway invocation.

4.3.12.3 Call maintenance phase

Not applicable.

TETRA SS-CAD is only applicable during call set-up.

4.3.13 Short Number Addressing (SS-SNA)

4.3.13.1 Incoming call set-up at ISDN gateway

Not applicable.

This service shall not effect normal call set-up.

4.3.13.2 Outgoing call set-up at ISDN gateway

No interaction.

This service shall not effect normal call set-up as the SS-SNA is only applicable to the air interface.

4.3.13.3 Call maintenance phase

No interaction.

This service shall not effect call maintenance phase.

4.3.14 Area Selection (SS-AS)

4.3.14.1 Incoming call set-up at ISDN gateway

An ISDN subscriber may upon call set-up invoke TETRA SS-AS using one of the following invocation methods:

- DTMF over dialling as described in the PSTN gateway standard ETS 300 392-4-1 [14] during call set-up;
- user-to-user signalling, encoding methods have been defined in the TETRA SS-AS standard, ETS 300 392-12-8 [18];
- permanent invocation of TETRA SS-AS within the SwMI, pre-defined area used;
- the subaddressing supplementary service may also be used during call set-up, however no coding method has been provided.

See TETRA SS-AS standard, ETS 300 392-12-8 [18] for further information.

4.3.14.2 Outgoing call set-up at ISDN gateway

Not applicable.

It shall not be possible for a TETRA user to select an area in the external network to where the call may be set-up.

4.3.14.3 Call maintenance phase

Not applicable.

4.3.15 Access Priority (SS-AP)

4.3.15.1 Incoming call set-up at ISDN gateway

Not applicable.

This service is used to gain radio link access in times of congestion.

4.3.15.2 Outgoing call set-up at ISDN gateway

Not applicable.

This service is used to gain radio link access in times of congestion.

4.3.15.3 Call maintenance phase

Not applicable.

This service is used to gain radio link access in times of congestion.

4.3.16 Priority Call (SS-PC)

4.3.16.1 Incoming call set-up at ISDN gateway

An ISDN subscriber may upon call set-up invoke TETRA SS-PC using one of the following invocation methods:

- DTMF overdialling as described in the PSTN gateway standard ETS 300 392-4-1 [14] during call set-up;
- user-to-user signalling, encoding methods have been defined in the TETRA SS-PC standard, ETS 300 392-12-10 [19];
- permanent invocation of TETRA SS-PC within the SwMI, pre-defined priority used;
- the subaddressing supplementary service may also be used during call set-up, however no coding method has been provided.

See TETRA SS-PC standard, ETS 300 392-12-10 [19] for further information.

4.3.16.2 Outgoing call set-up at ISDN gateway

Not applicable.

No similar supplementary service exist for ISDN DSS1. It is therefore not possible to request TETRA priority levels to an ISDN subscriber.

4.3.16.3 Call maintenance phase

Not applicable.

TETRA SS-PC is only applicable during call set-up.

4.3.17 Call Waiting (SS-CW)

4.3.17.1 Incoming call set-up at ISDN gateway

If call waiting is invoked for a called TETRA user, the ISDN network should be informed of call waiting in the notification information element of the ISDN ALERTING message.

NOTE: See EN 300 058-1 [1] clause 10.

4.3.17.2 Outgoing call set-up at ISDN gateway

Not applicable.

TETRA SS-CW is only applicable for incoming calls.

4.3.17.3 Call maintenance phase

Not applicable.

TETRA SS-CW is only applicable during call set-up.

4.3.18 Call Hold (SS-HOLD)

4.3.18.1 Incoming call set-up at ISDN gateway

Not applicable.

TETRA SS-HOLD cannot be invoked during the call set-up phase.

4.3.18.2 Outgoing call set-up at ISDN gateway

Not applicable.

TETRA SS-HOLD cannot be invoked during the call set-up phase.

4.3.18.3 Call maintenance phase

If a TETRA user chooses to set the ISDN subscriber on HOLD, then the ISDN network should be informed.

NOTE: See EN 300 141-1 [5] subclauses 9.2.1 and 9.4.1.

4.3.19 Call Completion to Busy Subscriber (SS-CCBS)

4.3.19.1 Incoming call set-up at ISDN gateway

TETRA SS-CCBS must be supported if ISDN SS-CCBS interactions are supported. See ETS 300 392-12-13 [20] subclause 5.5.1.

4.3.19.2 Outgoing call set-up at ISDN gateway

Interactions between the ISDN gateway and the ISDN network when TETRA SS-CCBS has been invoked is described in ETS 300 392-12-13 [20] subclause 5.5 and EN 300 359-1 [8] clause 10.

4.3.19.3 Call maintenance phase

Not applicable.

TETRA SS-CCBS is only applicable during call set-up.

4.3.20 Late Entry (SS-LE)

4.3.20.1 Incoming call set-up at ISDN gateway

Not applicable.

TETRA SS-LE signalling occurs during the maintenance phase of a group call.

4.3.20.2 Outgoing call set-up at ISDN gateway

Not applicable.

TETRA SS-LE signalling occurs during the maintenance phase of a group call.

4.3.20.3 Call maintenance phase

Not applicable.

TETRA SS-LE signalling shall not be sent to external ISDN subscribers.

4.3.21 Transfer of Control (SS-TC)

4.3.21.1 Incoming call set-up at ISDN gateway

Not applicable.

TETRA SS-TC shall not be invoked during call set-up.

4.3.21.2 Outgoing call set-up at ISDN gateway

Not applicable.

TETRA SS-TC shall not be invoked during call set-up.

4.3.21.3 Call maintenance phase

Not applicable.

An ISDN subscriber shall not receive call ownership over a group call. It shall therefore not be applicable for the ISDN gateway to support TETRA SS-TC.

4.3.22 Pre-emptive Priority Call (SS-PPC)

4.3.22.1 Incoming call set-up at ISDN gateway

An ISDN subscriber may upon call set-up invoke TETRA SS-PPC using one of the following invocation methods:

- DTMF over dialling as described in the PSTN gateway standard ETS 300 392-4-1 [14] during call set-up;
- user-to-user signalling, encoding methods have been defined in the TETRA SS-PPC standard, ETS 300 392-12-16 [21];
- permanent invocation of TETRA SS-PPC within the SwMI, pre-defined priority used;
- the subaddressing supplementary service may also be used during call set-up, however no coding method has been provided.

See TETRA SS-PPC standard, ETS 300 392-12-16 [21] for further information.

4.3.22.2 Outgoing call set-up at ISDN gateway

Not applicable.

No similar supplementary service exist for ISDN DSS1. It is therefore not possible to request TETRA pre-emptive priority levels to an ISDN subscriber.

4.3.22.3 Call maintenance phase

Not applicable.

TETRA SS-PPC is only applicable during call set-up.

4.3.23 Include Call (SS-IC)

4.3.23.1 Incoming call set-up at ISDN gateway

Not applicable.

TETRA SS-IC is not applicable during the call set-up phase.

4.3.23.2 Outgoing call set-up at ISDN gateway

Not applicable.

TETRA SS-IC is not applicable during the call set-up phase.

4.3.23.3 Call maintenance phase

No interactions.

When a request to include an external ISDN subscriber has been made, normal call set-up procedures shall be initiated towards the ISDN network. No indication shall be given to the ISDN subscriber that it has been included in an active call.

Invocation of the TETRA SS-IC service by an ISDN subscriber is not defined by this ETS.

4.3.24 Advice of Charge (SS-AoC)

4.3.24.1 Incoming call set-up at ISDN gateway

No information available.

4.3.24.2 Outgoing call set-up at ISDN gateway

No information available.

4.3.24.3 Call maintenance phase

No information available.

4.3.25 Barring of Outgoing Calls (SS-BOC)

4.3.25.1 Incoming call set-up at ISDN gateway

Not applicable.

TETRA SS-BOC is not applicable to an ISDN calling user.

4.3.25.2 Outgoing call set-up at ISDN gateway

Not interaction.

No TETRA call set-up request shall be sent to the ISDN gateway if outgoing calls are barred for the calling TETRA user.

4.3.25.3 Call maintenance phase

Not applicable.

ISDN SS-BOC is only invoked during call set-up.

4.3.26 Barring of Incoming Calls (SS-BIC)

4.3.26.1 Incoming call set-up at ISDN gateway

No ISDN DSS1 supplementary service exist for barring of incoming calls. Only the ISDN DISCONNECT or ISDN RELEASE message is sent with an appropriate cause.

4.3.26.2 Outgoing call set-up at ISDN gateway

Not applicable.

TETRA SS-BIC is not applicable to an ISDN calling user.

4.3.26.3 Call maintenance phase

Not applicable.

ISDN SS-BIC is only invoked during call set-up.

4.3.27 Discreet Listening (SS-DL)

4.3.27.1 Incoming call set-up at ISDN gateway

No interaction.

Monitoring users inside a TETRA network by an ISDN subscriber shall not be accepted. SS-DL cannot be invoked by an external ISDN user, however an ISDN subscriber may participate in a monitored call.

4.3.27.2 Outgoing call set-up at ISDN gateway

No interaction.

An ISDN subscriber may participate in a monitored call.

4.3.27.3 Call maintenance phase

No interaction.

An ISDN subscriber may participate in a monitored call.

4.3.28 Ambience Listening (SS-AL)

Not applicable.

Monitoring users outside of any TETRA network (PSTN, ISDN,...) shall not be accepted.

SS-AL cannot be invoked by an ISDN subscriber.

NOTE: TETRA SS-AL is invoked when the called unit is not engaged in a call.

4.3.29 Dynamic Group Number Assignment (SS-DGNA)

4.3.29.1 Incoming call set-up at ISDN gateway

No interaction.

This service shall not effect normal call set-up.

4.3.29.2 Outgoing call set-up at ISDN gateway

No interaction.

This service shall not effect normal call set-up.

4.3.29.3 Call maintenance phase

No interaction.

This service shall not effect call maintenance phase.

4.3.30 Call Completion on No Reply (SS-CCNR)

4.3.30.1 Incoming call set-up at ISDN gateway

Not applicable.

TETRA SS-CCNR shall be invoked by a TETRA calling user. For incoming gateway calls, the calling user is an ISDN subscriber. See subclause 4.4.4.1 invocation of ISDN SS-CCBS.

4.3.30.2 Outgoing call set-up at ISDN gateway

Interactions between the ISDN gateway and the ISDN network when TETRA SS-CCNR has been invoked is described in ETS 300 392-12-23 [22] subclause 7.4.2 and EN 301 065-1 [2] clause 10.

4.3.30.3 Call maintenance phase

Not applicable.

TETRA SS-CCNR is only applicable during call set-up.

4.3.31 Call Retention (SS-CRT)

4.3.31.1 Incoming call set-up at ISDN gateway

Not applicable.

It is not possible for an external subscriber to initiate call set-up with a call retention value as ISDN does not support this.

4.3.31.2 Outgoing call set-up at ISDN gateway

Not applicable.

Call retention values are not sent between networks.

4.3.31.3 Call maintenance phase

No interaction.

The retention value may only be supported by the TETRA network.

4.4 Interactions with ISDN supplementary services

Interactions with ISDN supplementary services for which ISDN Standards were available at the time of publication of this Standard are specified below. The following interactions shall be defined for each TETRA supplementary service:

- incoming call set-up at ISDN gateway;
- outgoing call set-up at ISDN gateway;
- call maintenance phase.

This subclause defines how and when a ISDN supplementary service will interact with the ISDN gateway and TETRA network when this service has been invoked in ISDN.

4.4.1 Three-Party (3PTY)

4.4.1.1 Incoming call set-up at ISDN gateway

Not applicable.

This service is only invoked during the maintenance phase of the call.

4.4.1.2 Outgoing call set-up at ISDN gateway

Not applicable.

This service is only invoked during the maintenance phase of the call.

4.4.1.3 Call maintenance phase

Invoked by ISDN subscriber:

A ISDN NOTIFY message will be received at the ISDN gateway. The Notification indicator information element of this message indicates the status of the 3PTY call.

The TETRA user shall be notified of the 3PTY call invocation or addition/reattachment of other users using "multiparty call" notification value according to procedures described in ETS 300 392-9 [15]. The other 3PTY status values are not mapped to TETRA notification values.

Invoked by TETRA user:

Not applicable.

Invocation of SS-3PTY shall not be supported for an TETRA user.

4.4.2 Advice of Charge (SS-AoC)

No interaction.

This service may be supported by the ISDN gateway, i.e. the ISDN gateway can subscribe to ISDN SS-AoC.

4.4.3 Call Completion to Busy Subscriber (CCBS)

4.4.3.1 Incoming call set-up at ISDN gateway

Interactions between the ISDN gateway and the ISDN network when ISDN SS-CCBS has been invoked is described in ETS 300 392-12-13 [20] subclause 7.4.1 and EN 300 359-1 [8] clause 10.

4.4.3.2 Outgoing call set-up at ISDN gateway

Not applicable.

ISDN SS-CCBS is invoked by an ISDN subscriber. For outgoing gateway calls, the calling user is a TETRA user.

4.4.3.3 Call maintenance phase

Not applicable.

ISDN SS-CCBS is only applicable during call set-up.

4.4.4 Call Completion on No Reply (CCNR)

4.4.4.1 Incoming call set-up at ISDN gateway

Interactions between the ISDN gateway and the ISDN network when ISDN SS-CCNR has been invoked are described in ETS 300 392-12-23 [22] subclause 7.4.1 and EN 301 065-1 [2] clause 10.

4.4.4.2 Outgoing call set-up at ISDN gateway

Not applicable.

ISDN SS-CCNR shall be invoked by an ISDN subscriber. For outgoing gateway calls, the calling user is a TETRA user.

4.4.4.3 Call maintenance phase

Not applicable.

ISDN SS-CCNR is only applicable during call set-up.

4.4.5 Call Deflection (CD)

4.4.5.1 Incoming call set-up at ISDN gateway

Information is given to the forwarded to TETRA user, in the case of a SS-CD call in the ISDN network. See ETS 300 392-12-4 [17] subclause 5.5.1.

4.4.5.2 Outgoing call set-up at ISDN gateway

If ISDN SS-CD is invoked for a called ISDN subscriber the ISDN network may inform the ISDN gateway of deflection. This information may be forwarded to the calling TETRA user according to ETS 300 392-12-4 [17] subclause 5.5.1.

4.4.5.3 Call maintenance phase

Not applicable.

ISDN SS-CD is only applicable during call set-up.

4.4.6 Call Forwarding Busy (CFB)

4.4.6.1 Incoming call set-up at ISDN gateway

Information is given to the forwarded to TETRA user, in the case of a SS-CFB call in the ISDN network. See ETS 300 392-12-4 [17] subclause 5.5.1.

The TETRA user shall be notified of call forwarding by the notification information element value "call is forwarded" according to procedures described in ETS 300 392-9 [15].

4.4.6.2 Outgoing call set-up at ISDN gateway

If ISDN SS-CFB is invoked for a called ISDN subscriber the ISDN network may inform the ISDN gateway of diversion. This information may be forwarded to the calling TETRA user by the notification information element value "call is forwarded" according to ETS 300 392-12-4 [17] subclause 5.5.1.

4.4.6.3 Call maintenance phase

Not applicable.

ISDN SS-CFB is only applicable during call set-up.

4.4.7 Call Forwarding on No Reply (CFNR)

4.4.7.1 Incoming call set-up at ISDN gateway

Information is given to the forwarded to TETRA user, in the case of a SS-CFNR call in the ISDN network. See ETS 300 392-12-4 [17] subclause 5.5.1.

The TETRA user shall be notified of call forwarding by the notification information element value "call is forwarded" according to procedures described in ETS 300 392-9 [15].

4.4.7.2 Outgoing call set-up at ISDN gateway

If ISDN SS-CFNR is invoked for a called ISDN subscriber the ISDN network may inform the ISDN gateway of diversion. This information may be forwarded to the calling TETRA user by the notification information element value "call is forwarded" according to ETS 300 392-12-4 [17] subclause 5.5.1.4.4.7.3 Call maintenance phase.

Not applicable.

ISDN SS-CFNR is only applicable during call set-up.

4.4.8 Call Forwarding Unconditional (CFU)

4.4.8.1 Incoming call set-up at ISDN gateway

Information is given to the forwarded to TETRA user, in the case of a SS-CFU call in the ISDN network. See ETS 300 392-12-4 [17] subclause 5.5.1.

The TETRA user shall be notified of call forwarding by the notification information element value "call is forwarded" according to procedures described in ETS 300 392-9 [15].

4.4.8.2 Outgoing call set-up at ISDN gateway

If ISDN SS-CFU is invoked for a called ISDN subscriber the ISDN network may inform the ISDN gateway of diversion. This information may be forwarded to the calling TETRA user by the notification information element value "call is forwarded" according to ETS 300 392-12-4 [17] subclause 5.5.1.

4.4.8.3 Call maintenance phase

Not applicable.

ISDN SS-CFU is only applicable during call set-up.

4.4.9 Calling Line Identification Presentation (CLIP)

4.4.9.1 Incoming call set-up at ISDN gateway

Not applicable.

ISDN SS-CLIP is invoked at an ISDN called user upon reception of a call set-up request.

4.4.9.2 Outgoing call set-up at ISDN gateway

No interaction.

The calling party number (E.164) is part of the basic call set-up signalling. Therefore, no further information is required from the ISDN gateway when the ISDN network has invoked/activated ISDN SS-CLIP.

NOTE 1: Three methods exist for mapping the TETRA ITSI to an ISDN subscriber number:

- 1) when no calling number is supplied by the TETRA network, the default calling party number shall be the ISDN gateway's ISDN number;
- 2) when the ISDN gateway holds a mapping between the TETRA ITSI and the ISDN number, i.e. due to support of ISDN SS-DDI for incoming calls, the mapped ISDN number shall be conveyed; and

- 3) when no mapping exist the ISDN gateway's ITSI can be used in the subaddressing information element.

NOTE 2: Tables 1 and 2 of EN 300 092-1 [3] define the calling party information which should be provided by the ISDN gateway.

4.4.9.3 Call maintenance phase

Not applicable.

ISDN SS-CLIP is only invoked during call set-up.

4.4.10 Calling Line Identification Restriction (CLIR)

4.4.10.1 Incoming call set-up at ISDN gateway

No interaction.

The presentation restriction indication is defined as part of the calling party number information element sent during basic call set-up from an ISDN subscriber. The ISDN SS-CLIR information shall be relayed to the TETRA SwMI.

4.4.10.2 Outgoing call set-up at ISDN gateway

Not applicable.

ISDN SS-CLIR is invoked at an ISDN calling user when calling line identification restriction is applicable.

4.4.10.3 Call maintenance phase

If ISDN SS-CLIR has been invoked during call set-up for an ISDN subscriber, the ISDN gateway shall indicate in transmission request from the ISDN subscriber that talking/sending party identification is restricted.

4.4.11 Connected Line Identification Presentation (COLP)

4.4.11.1 Incoming call set-up at ISDN gateway

No interaction.

The connected party number is part of the basic call set-up signalling. Therefore, no further information is required from the ISDN gateway when the ISDN network has invoked/activated ISDN SS-COLP.

Three methods exist for mapping the TETRA ITSI to an ISDN subscriber number:

- 1) when no connected party information is supplied by the TETRA network, the default connected party number shall be the ISDN gateway's ISDN number;
- 2) when the ISDN gateway holds a mapping between the TETRA ITSI and the ISDN number, i.e. due to support of ISDN SS-DDI for incoming calls, the mapped ISDN number shall be conveyed; and
- 3) when no mapping exist the ISDN gateway's ITSI can be used in the subaddressing information element.

NOTE: Tables 1 and 2 of EN 300 092-1 [3] define the calling party information which should be provided by the ISDN gateway.

4.4.11.2 Outgoing call set-up at ISDN gateway

Not applicable.

ISDN SS-COLP is invoked at an ISDN calling user upon reception of a connect indication.

4.4.11.3 Call maintenance phase

Not applicable.

ISDN SS-COLP is only invoked during call set-up.

4.4.12 Connected Line Identification Restriction (COLR)

4.4.12.1 Incoming call set-up at ISDN gateway

Not applicable.

ISDN SS-COLR is invoked at an ISDN called user upon reception of a call set-up request.

4.4.12.2 Outgoing call set-up at ISDN gateway

No interaction.

The presentation restriction indication is defined as part of the connected number information element sent during basic call set-up from an ISDN subscriber. The ISDN SS-COLR information shall be relayed to the TETRA SwMI.

NOTE: See EN 300 097-1 [4] for the definition of the information element connected number.

4.4.12.3 Call maintenance phase

If ISDN SS-COLR has been invoked during call set-up for an ISDN subscriber, the ISDN gateway shall indicate in transmission request from the ISDN subscriber that talking/sending party identification is restricted.

4.4.13 Conference call, add on (CONF)

4.4.13.1 Incoming call set-up at ISDN gateway

Not applicable.

If SS-CONF is initiated by an ISDN subscriber, the TETRA ISDN gateway will first be informed of the conference call after the call has been set-up (maintenance phase) between the conference switch and the ISDN gateway. The TETRA user shall be informed by the notification information element value "multiparty call" according to procedures described in ETS 300 392-9 [15].

4.4.13.2 Outgoing call set-up at ISDN gateway

Not applicable.

It shall not be applicable to connect external group members to a call using the ISDN CONF supplementary service.

4.4.13.3 Call maintenance phase

Invoked by ISDN subscriber either during call set-up or during the maintenance phase.

A ISDN NOTIFY message will be received at the ISDN gateway. The Notification indicator information element of this message indicates the status of the conference call.

The TETRA user shall be notified of the conference call by the notification information element value "multiparty call" according to procedures described in ETS 300 392-9 [15].

Invoked by TETRA user:

Not applicable.

Invocation of SS-CONF shall not be supported for an TETRA user.

4.4.14 Closed User Group (CUG)

No interaction.

4.4.15 Call Waiting (CW)

4.4.15.1 Incoming call set-up at ISDN gateway

Not applicable.

ISDN SS-CW is only invoked for outgoing calls.

4.4.15.2 Outgoing call set-up at ISDN gateway

If call waiting is invoked for a called ISDN subscriber, the ISDN network may inform the ISDN gateway of call waiting in the notification information element of the ISDN ALERTING message. The ISDN gateway shall forward this information to the controlling or other end TETRA call control application for the call.

NOTE: See EN 300 058-1 [1] clause 10.

The TETRA user shall be notified of call waiting by the notification information element value "call waiting invoked" according to procedures described in ETS 300 392-9 [15].

4.4.15.3 Call maintenance phase

Not applicable.

ISDN SS-CW is only invoked during call set-up.

4.4.16 Direct Dial In (DDI)

4.4.16.1 Incoming call set-up at ISDN gateway

Mapping may exist in the ISDN gateway. If no mapping exist, the ISDN gateway's ITSI is transferred in the SwMI.

4.4.16.2 Outgoing call set-up at ISDN gateway

Not applicable.

SS-DDI is only applicable for incoming calls.

4.4.16.3 Call maintenance phase

Not applicable.

ISDN SS-DDI is only invoked during incoming call set-up.

4.4.17 Explicit Call Transfer (ECT)

No interaction.

This service cannot be invoked by a TETRA user, however one or more TETRA users may be part of the resulting call.

The TETRA user may be notified by the notification information element value "call forwarded" according to procedures described in ETS 300 392-9 [15].

4.4.18 Freephone (FPH)

4.4.18.1 Incoming call set-up at ISDN gateway

No interaction.

The ISDN gateway number may be a FPH number.

4.4.18.2 Outgoing call set-up at ISDN gateway

When establishing an outgoing freephone call from a TETRA user to an ISDN subscriber, the TETRA gateway SwMI shall support the freephone specific notification "call completion delay". This notification is received in an ISDN ALERTING message.

The TETRA user shall be notified that the call has been queued according to procedures described in ETS 300 392-2 [12].

4.4.18.3 Call maintenance phase

Not applicable.

ISDN SS-FPH is only invoked during call set-up.

4.4.19 Call Hold (HOLD)

4.4.19.1 Incoming call set-up at ISDN gateway

If ISDN SS-HOLD is invoked, the ISDN network will inform the ISDN gateway of SS-HOLD in a ISDN ALERTING message. The HOLD notification shall be terminated at the ISDN gateway. The ISDN gateway should reject the call set-up request.

NOTE: See EN 300 141-1 [5] subclauses 9.2.1 and 9.4.1.

4.4.19.2 Outgoing call set-up at ISDN gateway

Not applicable.

The called ISDN subscriber may only invoke ISDN SS-HOLD during the call active state.

4.4.19.3 Call maintenance phase

Invoked by ISDN subscriber:

A ISDN NOTIFY message will be received at the ISDN gateway. The Notification indicator information element of this message indicates the status of ISDN SS-HOLD.

The TETRA user shall be notified of the call status by the notification information element value "call put on hold" or "call on hold retrieved" as appropriate according to procedures described in ETS 300 392-9 [15].

Invoked by TETRA user:

Not applicable.

A TETRA user may invoke TETRA SS-HOLD. See subclause 4.3.18.

4.4.20 Malicious Call Identification (MCID)

Not applicable.

This service is not supported by the ISDN gateway.

4.4.21 Multiple Subscriber Number (MSN)

4.4.21.1 Incoming call set-up at ISDN gateway

No interaction.

4.4.21.2 Outgoing call set-up at ISDN gateway

No interaction.

This service shall not affect normal call set-up.

4.4.21.3 Call maintenance phase

No interaction.

This service shall not effect normal call maintenance phase.

4.4.22 Message Waiting Indication (MWI)

Not applicable.

This service shall not be supported by the ISDN gateway.

4.4.23 Outgoing Call Barring (OCB)

4.4.23.1 Incoming call set-up at ISDN gateway

No interaction.

No ISDN call set-up request is sent to the ISDN gateway if outgoing calls are barred for the ISDN subscriber.

4.4.23.2 Outgoing call set-up at ISDN gateway

Not applicable.

ISDN SS-OCB is not applicable to a TETRA calling user.

4.4.23.3 Call maintenance phase

Not applicable.

ISDN SS-OCB is only invoked during call set-up.

4.4.24 Subaddressing (SUB)

4.4.24.1 Incoming call set-up at ISDN gateway

The called ITSI may be mapped respectively into the called party information element of the TETRA call set-up primitives.

4.4.24.2 Outgoing call set-up at ISDN gateway

No interaction.

The calling ITSI may be mapped respectively into the calling subaddressing information element of the ISDN SETUP message.

4.4.24.3 Call maintenance phase

Not applicable.

ISDN SS-SUB is only invoked during call set-up.

4.4.25 Terminal Portability (TP)

4.4.25.1 Incoming call set-up at ISDN gateway

Not applicable.

4.4.25.2 Outgoing call set-up at ISDN gateway

Not applicable.

The ISDN gateway will not interfere with SS-TP set in the ISDN network.

4.4.25.3 Call maintenance phase

Not applicable.

The ISDN gateway will not interfere with SS-TP set in the ISDN network.

4.4.26 User-to-User signalling (UUS)

4.4.26.1 Incoming call set-up at ISDN gateway

The ISDN gateway may support UUS service 3 activation during call set-up.

4.4.26.2 Outgoing call set-up at ISDN gateway

The ISDN gateway may support activation of UUS service 3 during call set-up.

4.4.26.3 Call maintenance phase

The ISDN gateway shall support UUS specific Facility information element values sent during the call maintenance phase for the purpose of supporting TETRA maintenance signalling, if UUS service 3 has been activated. Thus, the UUS service is terminated in the ISDN gateway and end-to-end user information is not supported.

4.5 Interworking considerations

ISDN gateway functions shall not interact with ISI. Outgoing call to ISDN may be routed to a SwMI other than the originating SwMI. Incoming calls from ISDN may be routed to a SwMI other than the gateway SwMI.

4.6 ISDN gateway service description

This subclause describes the services offered by the ISDN gateway at the Circuit Mode Control Entity (CMCE) CC Service Access Point (ISDNCC-SAP) of a TETRA V+D layer 3 service boundary inside a SwMI.

4.6.1 ISDN gateway service

4.6.1.1 ISDN gateway primitives exchanged through the ISDNCC-SAP

The flow of ISDN gateway primitives shall be as illustrated in figure 1.

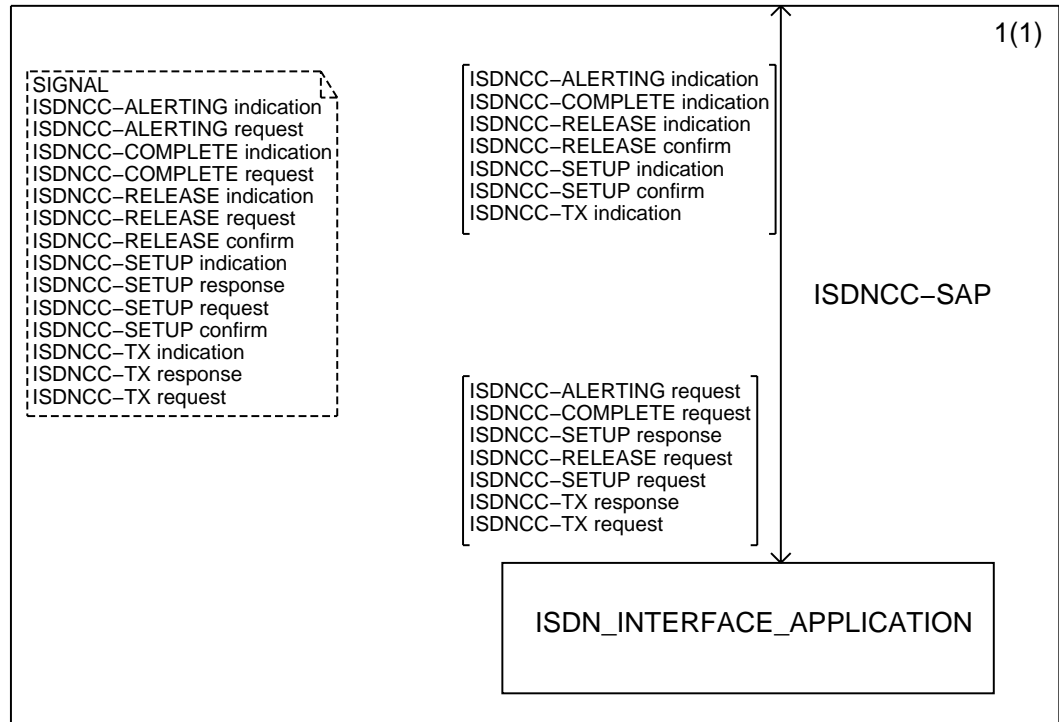

Figure 1: ISDN gateway services provided at the ISDNCC-SAP

4.6.1.2 Service primitives at the ISDNCC-SAP

The set of service primitives available at the ISDNCC-SAP shall be as specified in this subclause.

ISDNCC-ALERTING request/indication: the primitive shall be used in the call set-up phase towards or from the ISDN interface application when on/off hook signalling is employed for an individual call and when queuing of a group call is performed.

ISDNCC-COMPLETE request/indication: the primitive shall be used as a termination of the call set-up phase at the ISDN interface application.

ISDNCC-RELEASE request/indication/confirm: the primitives shall be used to initiate the call release phase. Further it shall be used to indicate the termination of the call release phase. The primitives may also be used during the call set-up phase to request or indicate rejection of a call.

ISDNCC-SETUP request/indication/response/confirm: the primitive shall be used to initiate the call set-up phase and shall also be used to indicate the termination of the call set-up phase. Response indicates the state of the call set-up (queuing).

ISDNCC-TX request/indication/response: the primitives shall be used during call active phase to request and indicate change in the transmission permission.

4.6.1.3 Service primitive description

Tables 1 to 4 below list the parameters in the information flows show in subclause 5.2.1. The columns indicate which parameters are mandatory (M), which are optional (O) and which are conditional (C).

NOTE: '-' indicates that the parameter is not used.

4.6.1.3.1 ISDNCC-ALERTING primitive

ISDNCC-ALERTING request shall be used by the ISDN gateway SwMI call control application to indicate that the call has been received by the controlling or other end TETRA entity for the call. ISDNCC-ALERTING request shall be received regardless of whether on/off hook signalling or direct call set-up signalling is used at the called user application.

ISDNCC-ALERTING indication shall be used by the ISDN gateway interface entity to indicate that the call has been received by the ISDN subscriber and alerting has been initiated.

No parameters are defined for the ISDNCC-ALERTING primitive.

4.6.1.3.2 ISDNCC-COMPLETE primitive

ISDNCC-COMPLETE request shall be used by the ISDN gateway SwMI call control application to complete call set-up.

ISDNCC-COMPLETE indication shall be used by the ISDN gateway interface entity to complete call set-up.

The parameters are defined in table 1.

Table 1: Parameters for the primitive ISDNCC-COMPLETE

Parameters	Request	Indication
Simplex/duplex selection	M (note 1)	
Transmission request permission	C (note 2)	-
Transmission grant	C (note 2)	-
NOTE 1: Used by the ISDN gateway interface when transmission request and granting occurs.		
NOTE 2: Conditional on the value of the simplex/duplex selection. Shall be applicable if simplex call is initiated.		

4.6.1.3.3 ISDNCC-RELEASE primitive

ISDNCC-RELEASE request shall be used by the ISDN gateway SwMI call control application to request the ISDN interface to release all external subscribers connected to the call. The call identifier and ISDN connection shall also be released.

ISDNCC-RELEASE indication shall be used by the ISDN gateway interface entity to indicate that an external ISDN subscriber has been released.

ISDNCC-RELEASE confirm shall be used by the ISDN gateway interface entity to indicate that the call (call identifier and ISDN connection) has been released when release was requested by the ISDN gateway SwMI call control application.

The parameters are defined in table 2.

Table 2: Parameters for the primitive ISDNCC-RELEASE

Parameters	Request	Indication	Confirm
Disconnect cause	M	M	-

4.6.1.3.4 ISDNCC-SETUP primitive

ISDNCC-SETUP request shall be used by the ISDN gateway SwMI call control application to initiate a circuit switched call towards the ISDN network. The called external subscriber number may be repeated if several external ISDN subscribers are to be connected to the call.

ISDNCC-SETUP indication shall be used by the ISDN gateway interface entity to indicate that an external ISDN subscriber has requested for a circuit switched call to be established to a TETRA user or group. Transmission shall be implicitly requested by the calling ISDN subscriber.

ISDNCC-SETUP response shall be used by the ISDN gateway SwMI call control application to indicate that the call has been accepted and indicate the current status of the call set-up.

ISDNCC-SETUP confirm shall be used by the ISDN gateway interface entity to indicate that the call has been accepted by the ISDN network and that call set-up is proceeding.

The parameters are defined in table 3.

Table 3: Parameters for the primitive ISDNCC-SETUP

Parameters	Request	Indication	Response	Confirm
Called external subscriber number	M	O (note 1)	-	-
Called party identity	-	O (note 1)	-	-
Calling external subscriber number	O	O (note 2)	-	-
Calling party identity	O (note 3)	O (note 2)	-	-
Call status	-	-	O	O
Simplex/duplex selection	M (note 4)	-	M	-
Basic service information	M	M	-	-
Transmission request permission	C (note 5)	-	-	-
Transmission grant	C (note 5)	-	M	-
NOTE 1:	Called party address shall be included if either a subaddress has been received, SS-DDI has been used or the called external subscriber number is included (E164). The address may be the full ITSI or GTSI.			
NOTE 2:	Calling party address shall be included if a subaddress has been received from the ISDN network. This address may be the full ITSI.			
NOTE 3:	ITSI or the SS-DDI number put into the subaddressing information element.			
NOTE 4:	Used by the ISDN gateway interface when transmission request and granting occurs.			
NOTE 5:	Conditional on the value of the simplex/duplex selection. Shall be applicable if simplex call is initiated.			

4.6.1.3.5 ISDNCC-TX primitive

ISDNCC-TX request shall be used by the ISDN gateway SwMI call control application to indicate grant of transmission to a TETRA user or interruption or cease of transmission by a TETRA user.

ISDNCC-TX indication shall be used by the ISDN gateway interface entity to request for transmission or indicate that the ISDN subscriber has ceased transmission.

ISDNCC-TX response shall be used by the ISDN gateway SwMI call control application to indicate that the transmission request made by an ISDN subscriber has been granted or rejected (e.g. another user has been granted transmission).

The parameters are defined in table 4.

Table 4: Parameters for the primitive ISDNCC-TX

Parameters	Request	Indication	Response
External subscriber number	O (note)	M	-
Requesting party address	-	O	-
Transmission condition	-	M	-
Transmission request permission	M	-	M
Transmission status	M	-	M
NOTE: May be used when transmission is interrupted.			

4.6.1.4 Parameter descriptions

This subclause defines parameter values for the primitives described in subclause 5.2.2.

Basic service information (a set of parameters) =
circuit mode service;
encryption flag.

Call status =
0 call is progressing;
1 call is queued.

Called / Calling external subscriber number =
Up to 24 digits. Each digit shall be one of the following:
0 digit 0;
etc. etc...;
9 digit 9;
10 digit *;
11 digit #;
12 digit +.

Called gateway SSI =
Short Subscriber Identity.

Called / Calling party identity =
Up to 14-15 DTMF digits. Each digit shall be one of the following:
0 digit 0;
etc. etc...;
9 digit 9;
10 digit *;
11 digit #;
12 digit +.

Circuit mode service =
0 reserved;
1 speech service.

Disconnect cause =
0 cause not defined or unknown;
1 user requested disconnect;
2 called party busy;
3 called party not reachable;
4 called party does not support encryption;
5 congestion in infrastructure;
6 not allowed traffic case;
7 incompatible traffic case;
8 requested service not available;
9 pre-emptive use of resource;
10 invalid call identifier;
11 call rejected by the called party;
12 no idle air interface call control protocol sub-entity;

13	expiry of timer;
14	SwMI requested disconnection;
15	acknowledged service not completed;
16	reserved;
ect.	ect..;
28	external resources unavailable (i.e. no route to destination);
29	invalid number.

Encryption flag =

0	clear end-to-end transmission;
1	reserved.

NOTE: End-to-end encryption is NOT supported by the ISDN gateway. Encryption should be terminated at the ISDN gateway.

Simplex/duplex selection =

simplex requested;
duplex requested.

Transmission grant =

transmission granted;
transmission not granted;
transmission request queued;
transmission granted to another user.

Transmission request permission =

allowed to request for transmission;
not allowed to request for transmission.

Transmission status =

transmission ceased;
transmission granted;
transmission not granted;
transmission request queued;
transmission granted to another user;
transmission interrupt.

4.6.1.5 Overall SDL

Figures 2 through 6 contain the dynamic description of the TETRA ISDN gateway using the Specification and Description Language (SDL) defined in ITU-T Recommendation Z.100 [31]. The SDL process represents the behaviour of the ISDN gateway SwMI entity interconnected to an ISDN network.

The following conventions are used:

- the input signals from the left and output signals to the left represent primitives to and from the SwMI Call Control application;
- the input signals from the right represent primitives from the ISDN interface application.

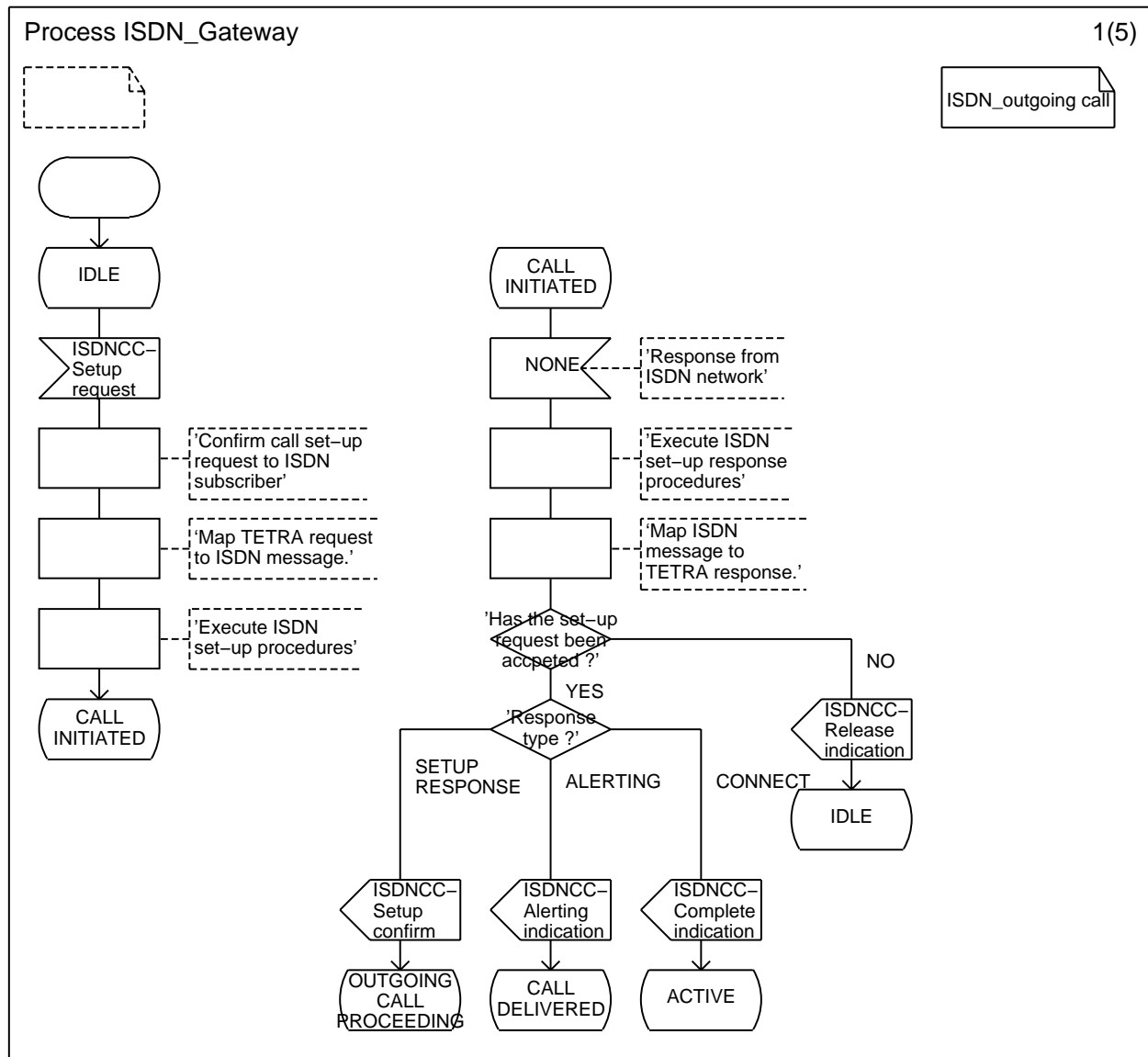

Figure 2: ISDN gateway, overall SDL sheet 1 of 5

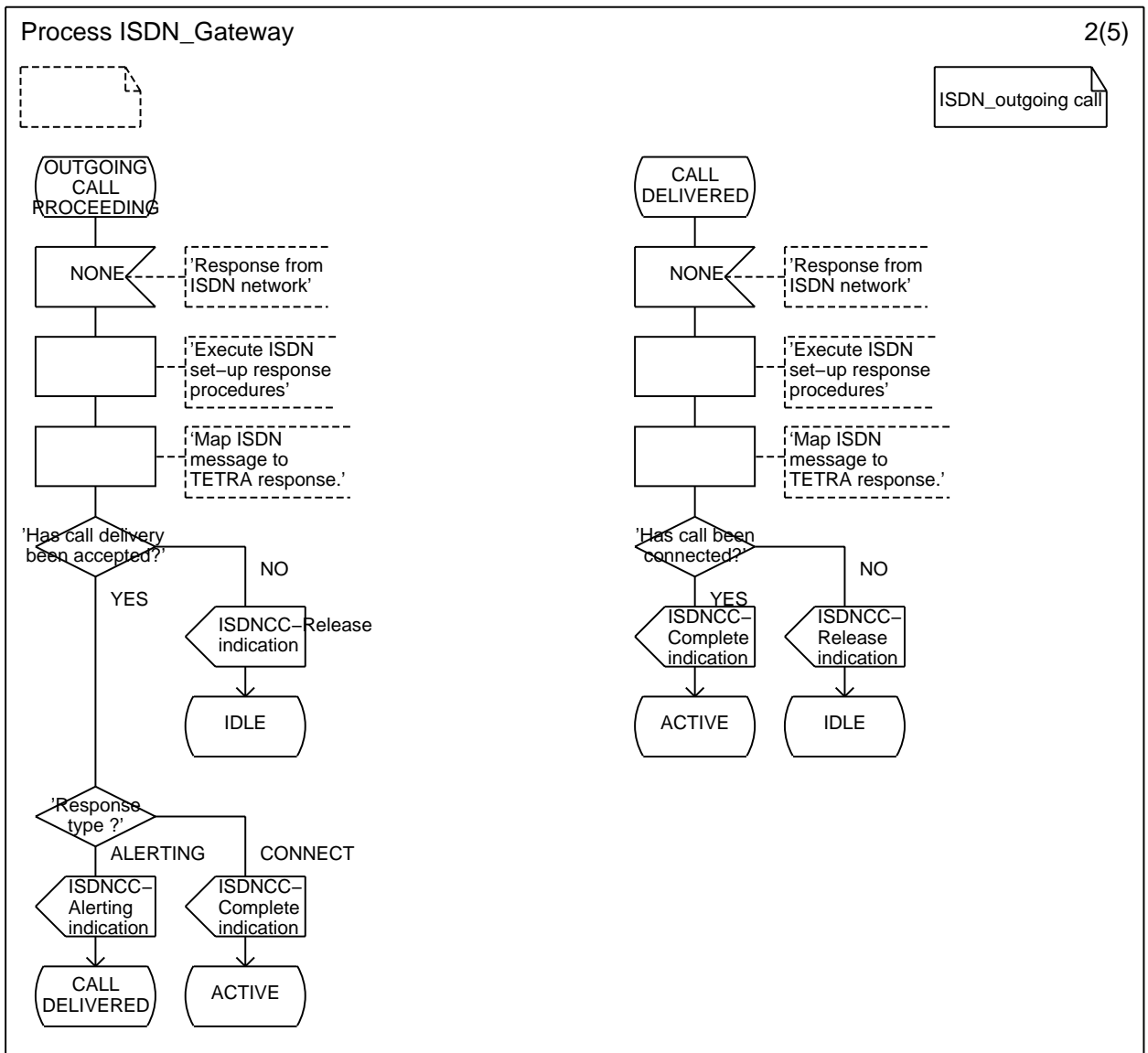

Figure 3: ISDN gateway, overall SDL sheet 2 of 5

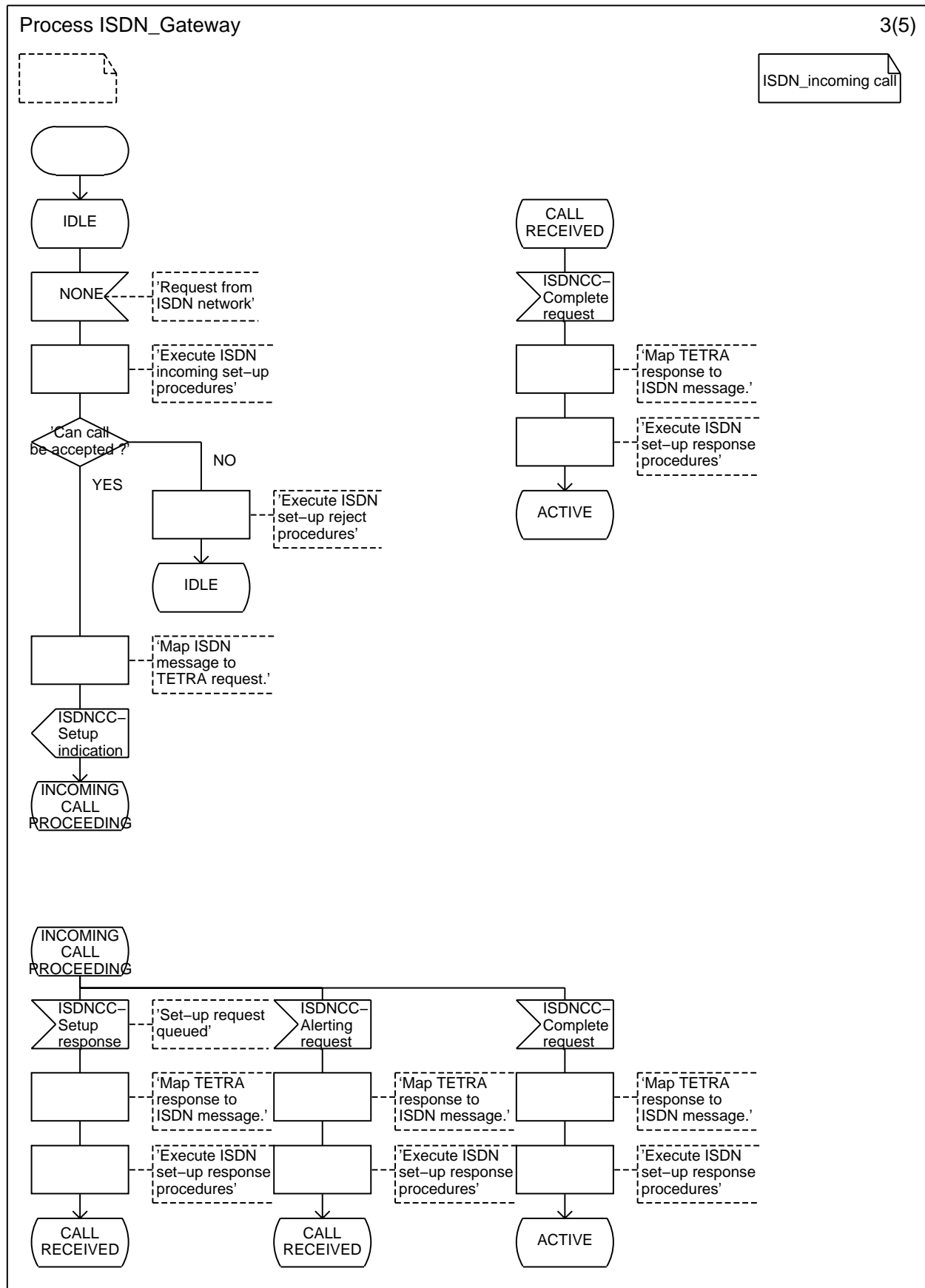

Figure 4: ISDN gateway, overall SDL sheet 3 of 5

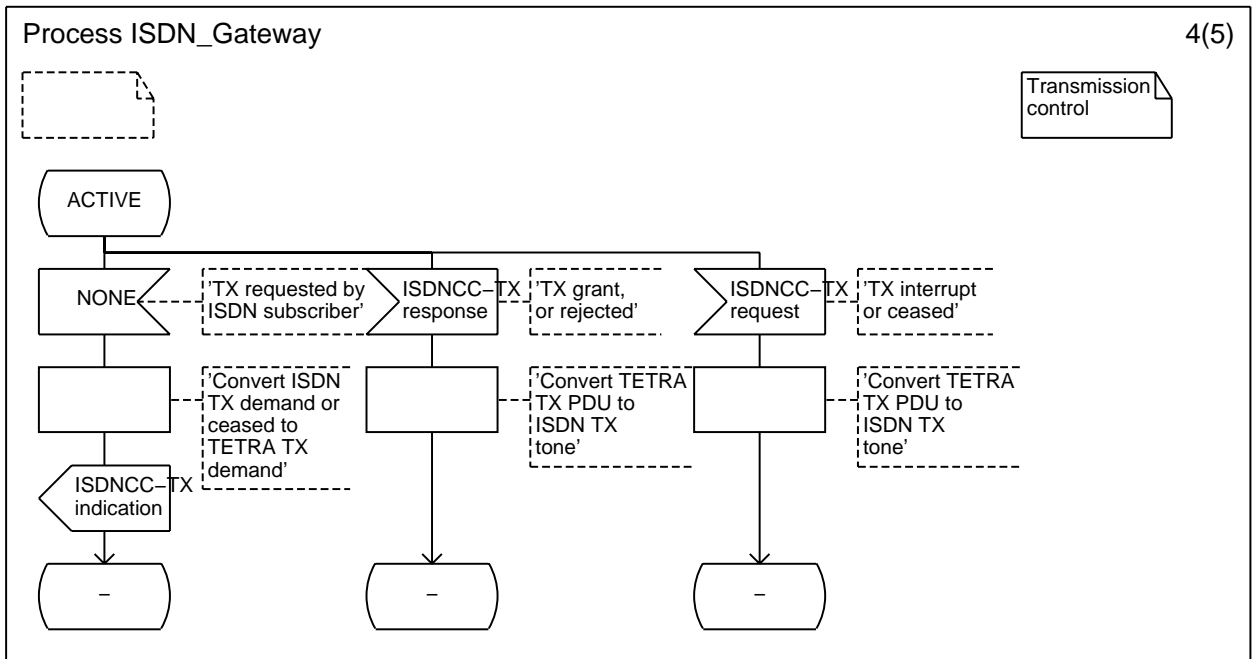

Figure 5: ISDN gateway, overall SDL sheet 4 of 5

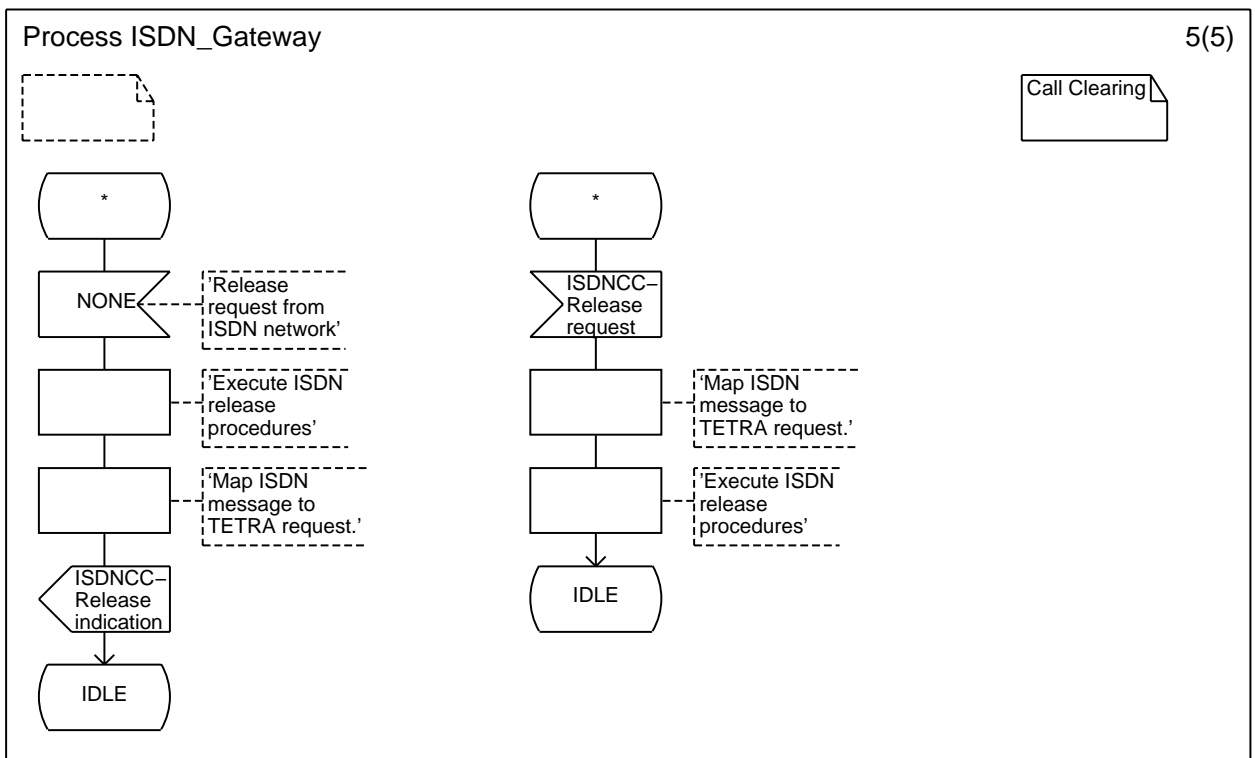

Figure 6: ISDN gateway, overall SDL sheet 5 of 5

4.6.1.6 Static description of ISDN gateway attributes

In accordance with ITU-T Recommendation I.210 [30], the static description of the ISDN gateway is given below using the relevant attributes with the corresponding values as defined in ITU-T Recommendation I.140 [29].

The ISDN gateway extends through the gateway to the ISDN network the TETRA bearer or teleservice invoked by a TETRA calling user by creating the necessary connection between the ISDN gateway SwMI and the ISDN network. Likewise, the ISDN gateway extends through the gateway to the TETRA network the ISDN bearer or teleservice invoked by an ISDN calling subscriber which are supported by the TETRA network. The corresponding bearer service attributes are given in annex C.

Using the terminology defined in ITU-T Recommendation I.140 [29] the ISDN gateway connection element has been identified.

Table 5 defines the static description of this connection element in terms of the values of its attributes as listed in ITU-T Recommendation I.140 [29].

NOTE 1: The attributes in the table below have been grouped into categories in a similar manner as in ITU-T Recommendation I.210 [30] for the bearer service attributes.

NOTE 2: It is not possible to change the information transfer rate of the 64 kbit/s connection elements, addressed in table 5.

Table 5: Basic definition of ISDN gateway connection element attributes

Attribute category	Attribute name	Attribute value TETRA ISDN gateway interface to ISDN network
Information transfer attributes	1. Information transfer mode: 2. Information transfer rate: 3. Information transfer capability: 4. Structure: 5. Establishment of connection: 6. Symmetry: 7. Connection configuration:	circuit 64 kbit/s speech 8 kHz integrity demand bi-directional symmetric point-to-point
Access attributes	8. Channel: 9. Connection control protocol: 10. Information transfer coding/protocol:	B_{ISDN} for user information, D_{ISDN} for signalling DSS1 for D_{ISDN} -channel Recommendation G.711 [26] A-law
General attributes	11. Network performance 12. Network interworking 13. Operations and management aspects	for further study for further study for further study

5 TETRA gateway stage 2 specification

5.1 Functional model

5.1.1 Functional model description

The functional model shall comprise the following functional entities:

FE1: SwMI call control application functional entity;

FE2: ISDN interface functional entity;

FE3: ISDN network.

The following functional relationship shall exist between these FEs:

ra: between FE1 and FE2;

rb: between FE2 and FE3.

Figure 7 shows the FEs and their relationship.

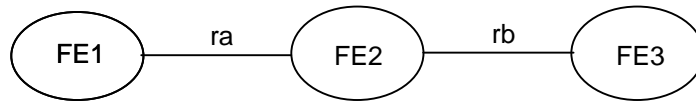

Figure 7: Functional model for ISDN gateway relationship

5.1.2 Description of functional entities

5.1.2.1 SwMI call control application functional entity, FE1

FE1 represents the circuit mode call control application functional entity for an ISDN gateway SwMI. FE1 shall route call set-up request made by a TETRA user to the ISDN interface functional entity when a call has been made to an ISDN subscriber. FE1 shall also receive call set-up request from the ISDN interface functional entity when an ISDN subscriber has made a call set-up request to a TETRA user or group.

NOTE: FE1 is not standardized.

5.1.2.2 ISDN interface functional entity, FE2

FE2 represents the ISDN user side towards the ISDN network. The purpose of this FE shall be to initiate an outgoing call towards an external subscriber when requested by FE1 or to forward an incoming call request to FE2. FE2 shall convert incoming ISDN messages to TETRA primitives and convert outgoing TETRA primitives to ISDN messages.

This functional entity shall:

- detect an outgoing call from FE1;
- determine the ISDN subscriber number;
- initiate ISDN call set-up signalling towards the ISDN network;
- detect an incoming call from an ISDN subscriber;
- determine TETRA identity from the ISDN SETUP message; or
- convert DTMF digits to TETRA identity when two step dialling is used;
- support ISDN call set-up and call clearing signalling;
- support ISDN transmission request and TETRA transmission responses;
- exchange signalling information with FE1;
- support TETRA call set-up and call clearing procedures.

5.1.2.3 ISDN network, FE3

FE3 represents the ISDN network at the T reference point or coincident S and T reference points. FE3 is defined in EN 300 403-1 [9] or relevant national requirements not covered by these standards.

NOTE: FE3 is not part of this standard.

5.2 Information flow

5.2.1 Information flow diagrams

This subclause specifies the information flow scenarios for the ISDN gateway basic services. The information flow scenarios shall provide sequences arising from error situations, interactions with DSS1 basic call, interactions with DSS1 supplementary services and TETRA supplementary services, different topologies, etc.

NOTE 1: The information flow scenarios in stage 2 do not cover all possible signalling scenarios.

The stage 3 description of this standard, EN 300 403-1 [9] or relevant national requirements not covered by these standards, shall provide signalling procedures in support of the information flow sequences specified below.

Within a column representing an ISDN gateway functional entity, the numbers refer to functional entity actions listed in 5.3. The following abbreviations are used:

- req: request;
- ind: indication;
- resp: response;
- conf: confirmation.

Columns have been made in the information flows below to represent the signalling between the ISDN network (FE3) and the ISDN interface functional entity FE2 and interactions between FE2 and the ISDN gateway SwMI call control application functional entity, FE1. The actions of the ISDN network and of FE1 are outside TETRA standardization. Therefore, no functional entity actions have been listed in subclause 5.3 for these interfaces.

NOTE 2: Actions performed by the ISDN network are described in the standards, EN 300 403-1 [9] or relevant national requirements not covered by these standards.

NOTE 3: Actions within the call control application of a SwMI are not standardized however, implicit behavior is assumed from the air interface standard ETS 300 392-2 [12] and from the ISI standard, ETS 300 392-3 [13].

5.2.1.1 Successful call set-up to an ISDN subscriber

There shall be no distinction between on/off hook signalling and direct call set-up signalling. FE2 is not informed of which hook method selection that has been chosen by the calling user or the TETRA SwMI.

Figure 8 shows a successful information flow sequence for an individual or group call set-up to an ISDN subscriber through an ISDN gateway. The external subscriber number is defined in the TETRA ISDNCC-SETUP request primitive.

For individual calls, transmission is granted per default to the ISDN subscriber for outgoing calls and to the TETRA user for incoming calls. For a group call, transmission is granted per default to the ISDN subscriber for incoming calls and to the TETRA user for outgoing calls.

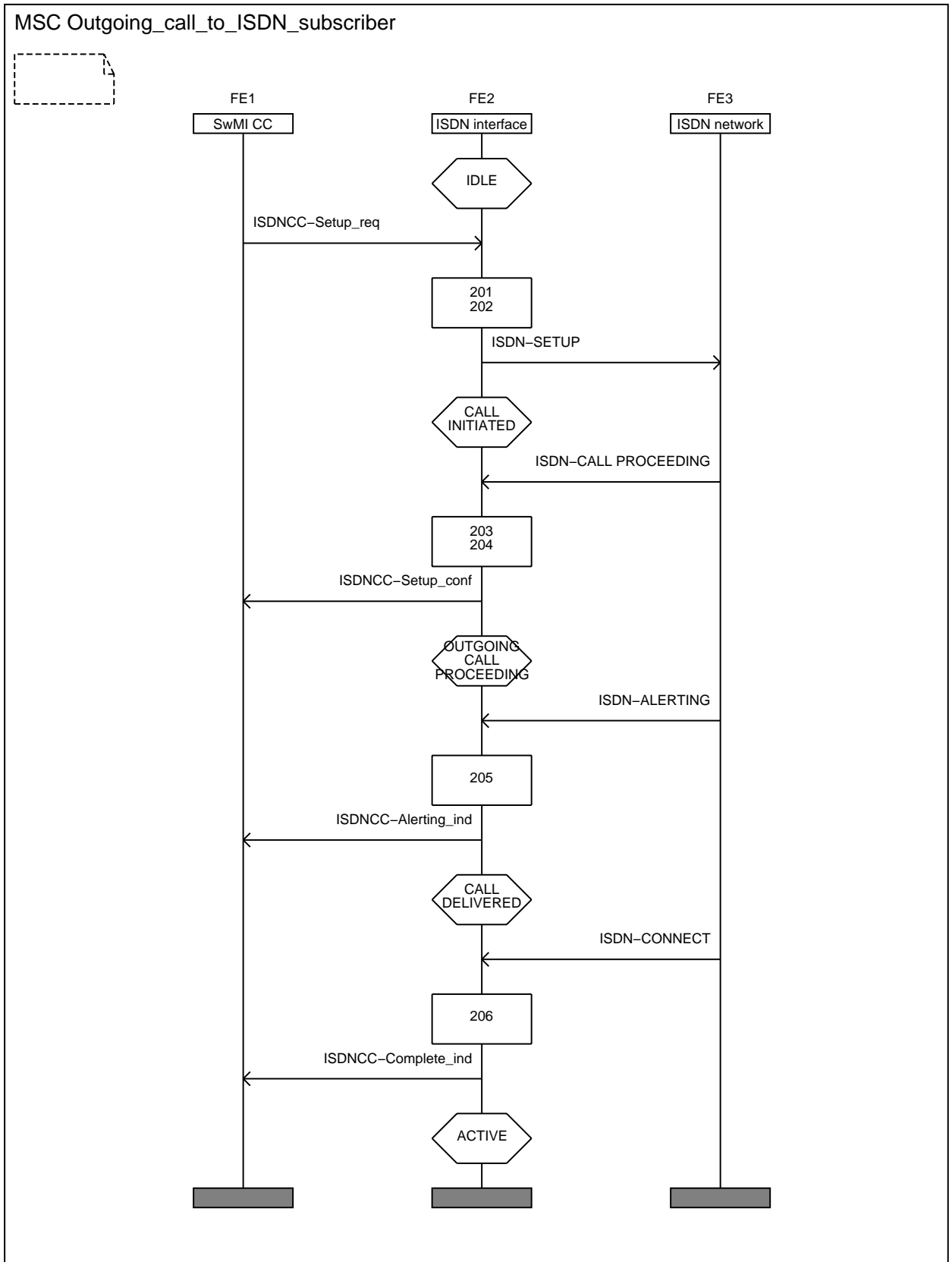

Figure 8: Information flow sequence - successful outgoing call set-up

5.2.1.2 Successful call set-up from an ISDN subscriber over the ISDN gateway

Figures 9 and 10 show a successful information flow sequence for call set-up from an ISDN subscriber through an ISDN gateway. The called TETRA user or TETRA group identity is defined:

- by the called party subaddress information element of the ISDN SETUP message when the ISDN Subaddressing supplementary service is used;
- in the called party number information element of the ISDN SETUP message when the ISDN Direct Dial In supplementary service is used; or
- received in-band (DTMF digits) when two stage dialling is used.

The following flows shall apply for individual and group calls where the calling user is an ISDN subscriber.

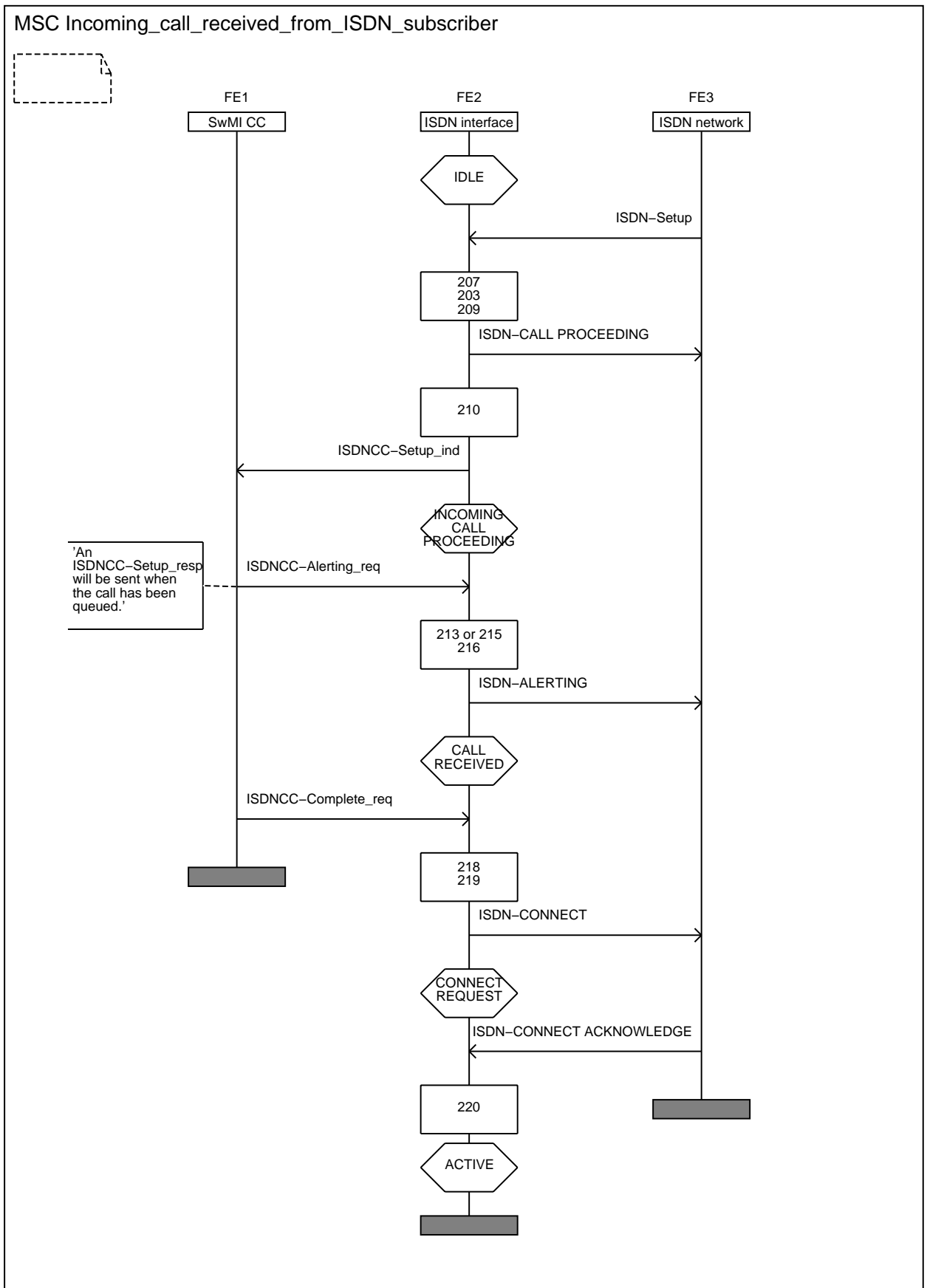

Figure 9: Information flow sequence - successful incoming call set-up

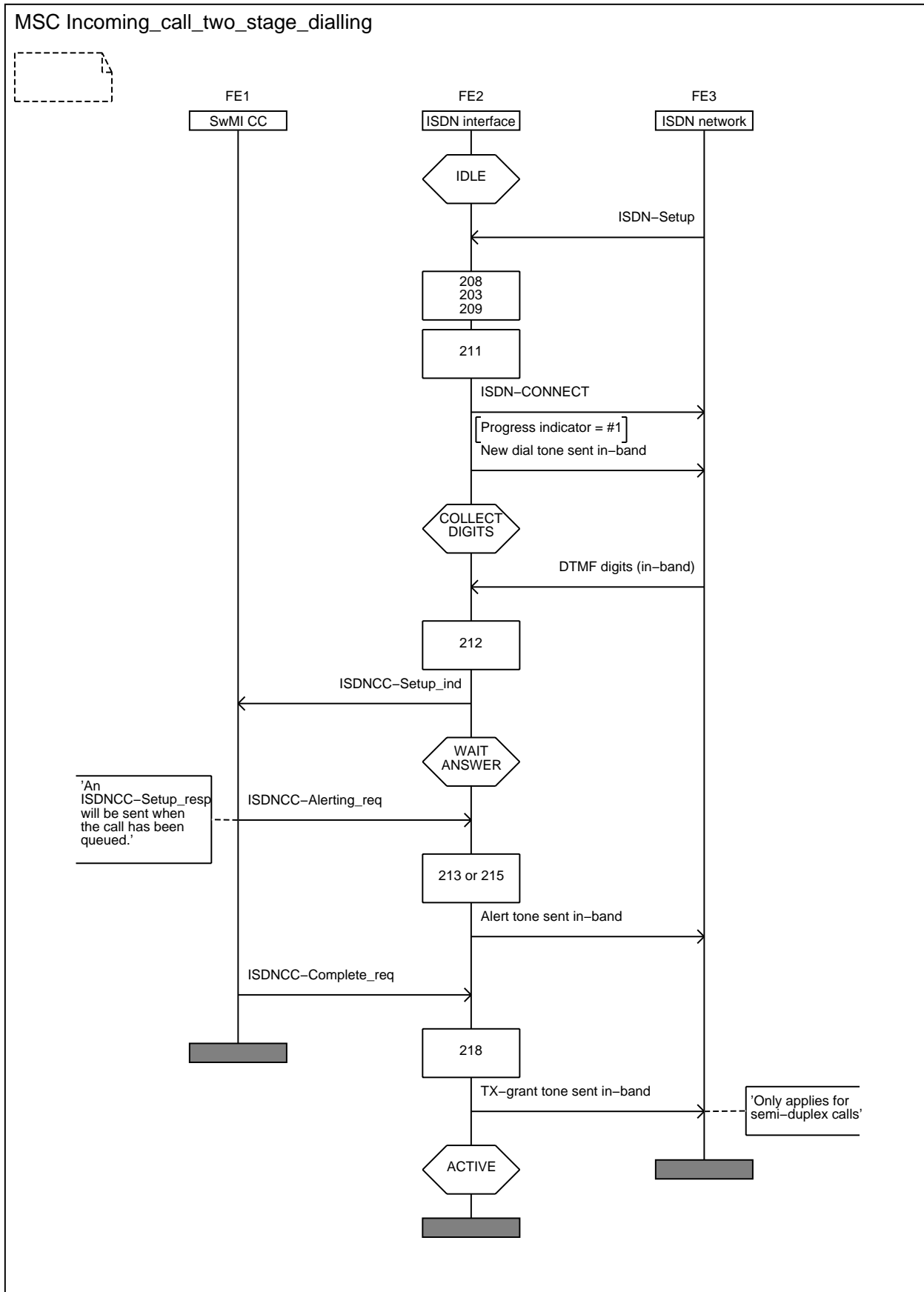

Figure 10: Information flow sequence - successful incoming call set-up, two stage dialling

Figure 10 shall continue as shown in figure 9, after state INCOMING CALL PROCEEDING.

When a semi-duplex call is initiated, the TX-GRANT tone shall be sent to the calling ISDN subscriber upon connect.

5.2.1.3 Call set-up request from an ISDN subscriber queued

If an ISDN call set-up request is queued by the controlling or other end SwMI for the call, the ISDN interface should be informed (ISDNCC-SETUP response primitive).

There is no method of indicating to the ISDN network that the call set-up request has been queued in the TETRA network. Therefore, the ISDN ALERTING message shall be sent to the ISDN network when an incoming call request has been queued so that the calling user is informed that call set-up is proceeding.

Upon reception of a TETRA ISDNCC-ALERTING request and after the ISDNCC-SETUP response has been received no actions shall be taken by the ISDN gateway interface functional entity.

Figure 11 shows an information flow sequence for a queued incoming call set-up request from an ISDN subscriber through an ISDN gateway.

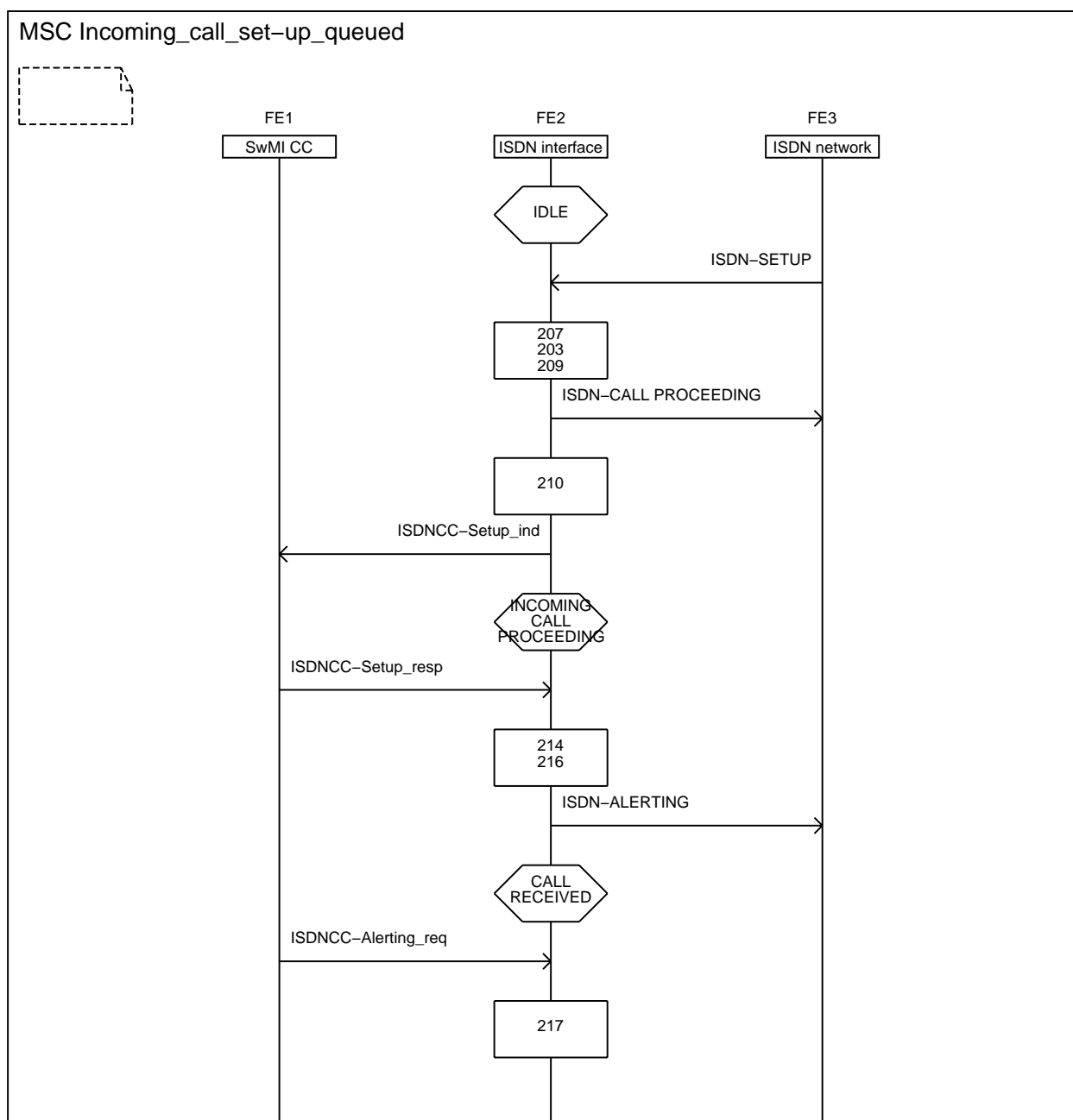

Figure 11: Information flow sequence - incoming call set-up queued

Figure 11 shall continue as shown in figure 9, state CALL RECEIVED.

5.2.1.4 Unsuccessful call set-up to an ISDN subscriber

Figure 12 shows an unsuccessful call set-up information flow sequence to an ISDN subscriber through an ISDN gateway. The ISDN subscriber is busy.

This flow shall apply for individual and group calls where the called user is an ISDN subscriber.

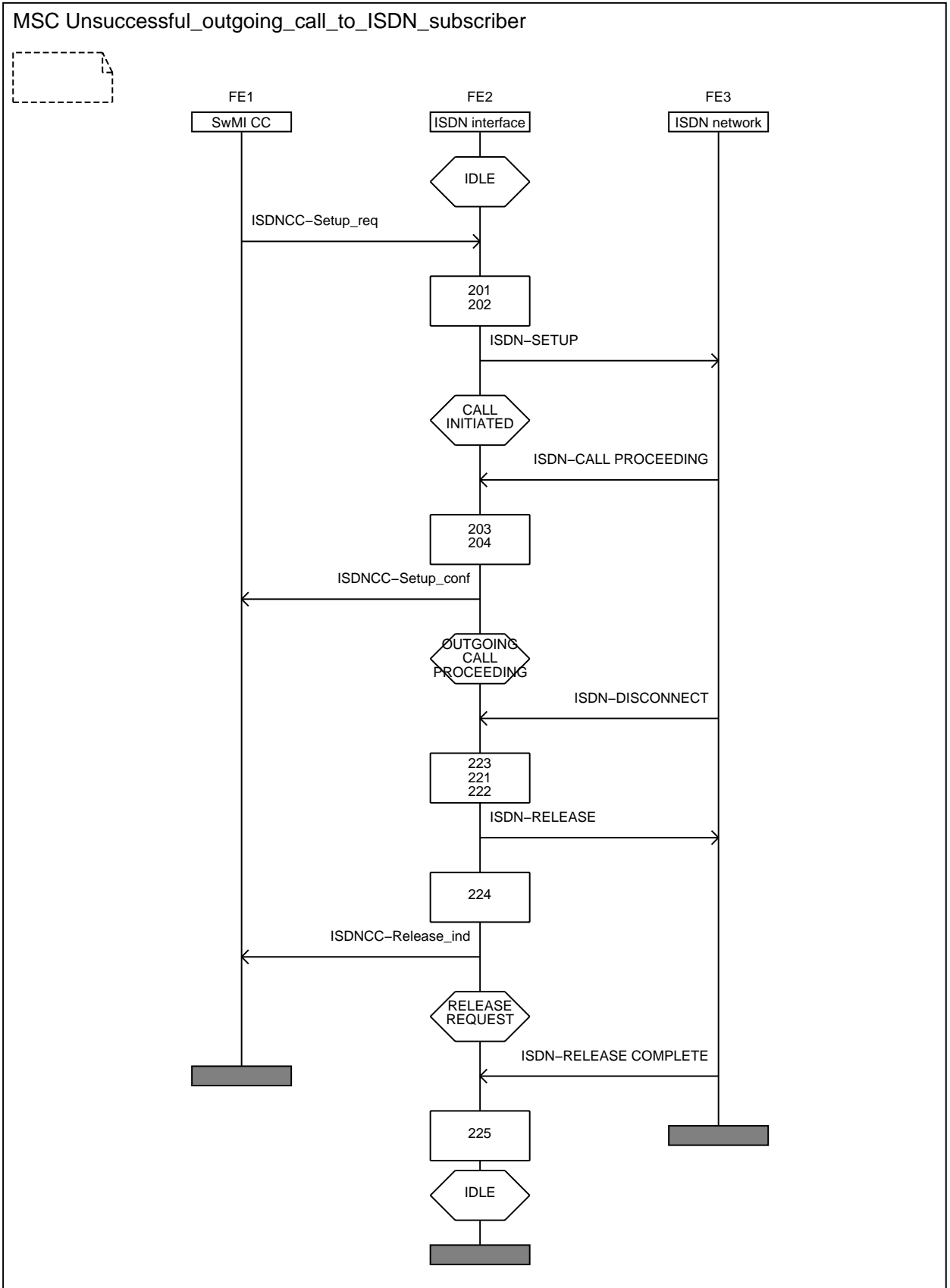

Figure 12: Information flow sequence - unsuccessful outgoing call set-up, busy subscriber

5.2.1.5 Unsuccessful call set-up from an ISDN subscriber

Figures 13 and 14 show an unsuccessful call set-up information flow sequence from an ISDN subscriber through an ISDN gateway.

This flow shall apply for individual or group calls where the calling user is an ISDN subscriber.

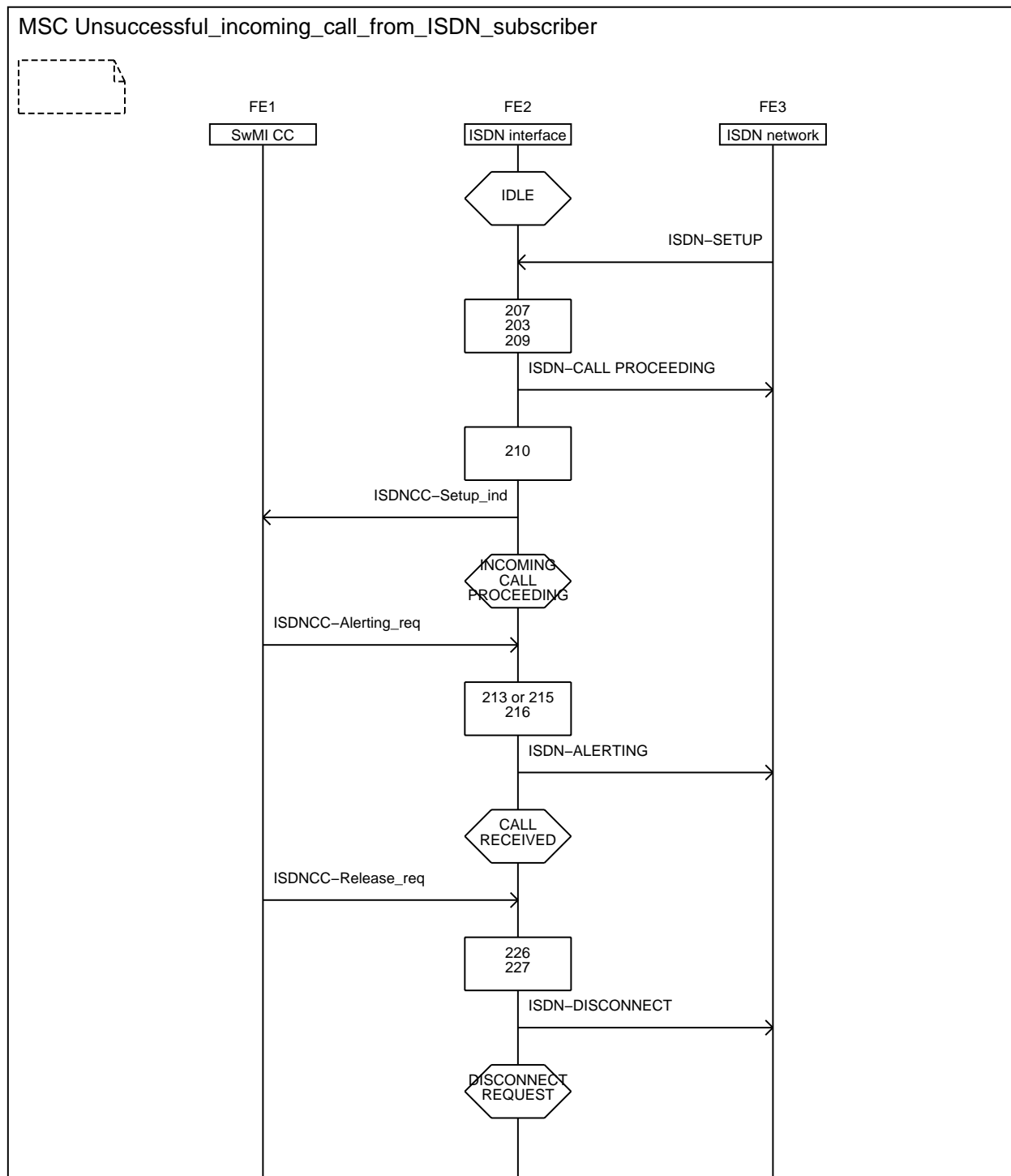

Figure 13: Information flow sequence - unsuccessful incoming call set-up

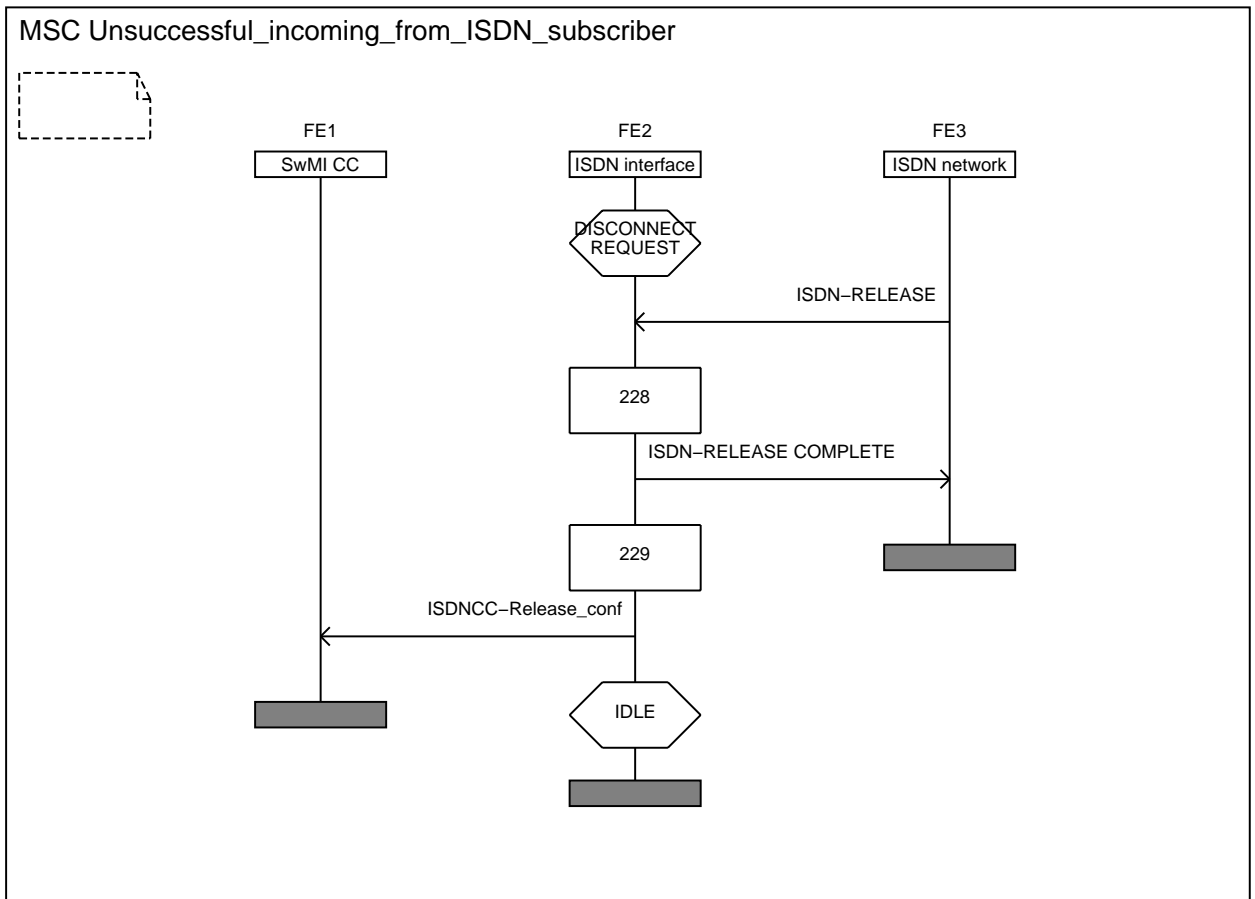

Figure 14: Information flow sequence - unsuccessful incoming call set-up

5.2.1.6 Unsuccessful call set-up, B-channel not accepted

Figure 15 shows an unsuccessful call set-up information flow sequence from an ISDN subscriber through the ISDN gateway. The B-channel indicated by the ISDN network was unavailable or not acceptable therefore a new B-channel has been indicated in the ISDN CALL PROCEEDING message.

The new B-channel is unacceptable to the ISDN network and the call is released.

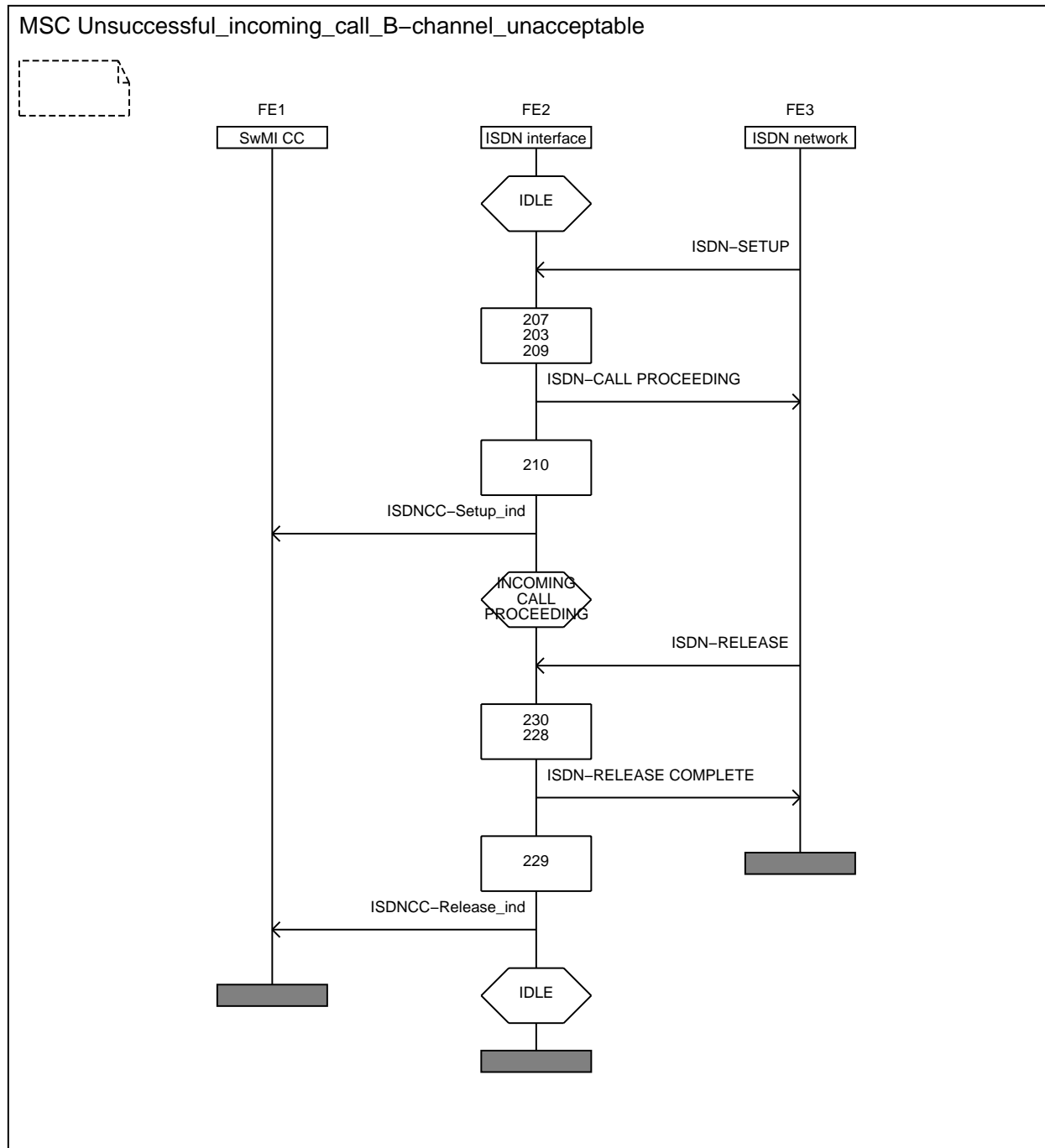
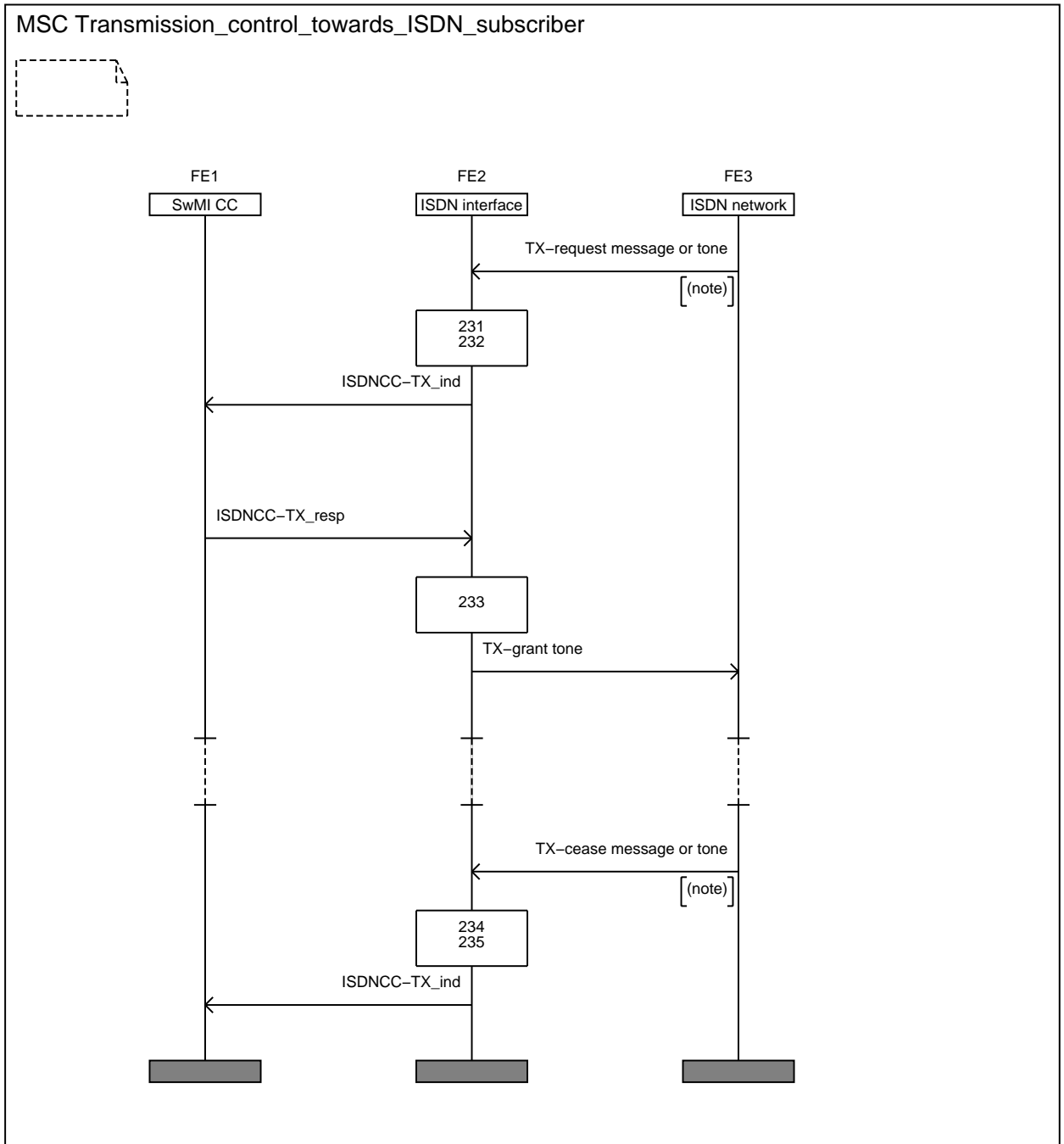

Figure 15: Information flow sequence - unsuccessful incoming call set-up, new B-channel not accepted

5.2.1.7 Call maintenance procedures - Transmission control towards an ISDN subscriber

Figure 16 shows a request to transmit from an ISDN subscriber and cease of transmission from the ISDN subscriber.



NOTE: Voice activity detection may be used instead of ISDN messages or tones at the ISDN gateway interface.

Figure 16: Information flow sequence - request and cease of transmission from an ISDN subscriber

5.2.1.8 Call maintenance procedures - Interrupt of transmitting ISDN subscriber

Figure 17 shows interrupt of transmission towards an ISDN subscriber.

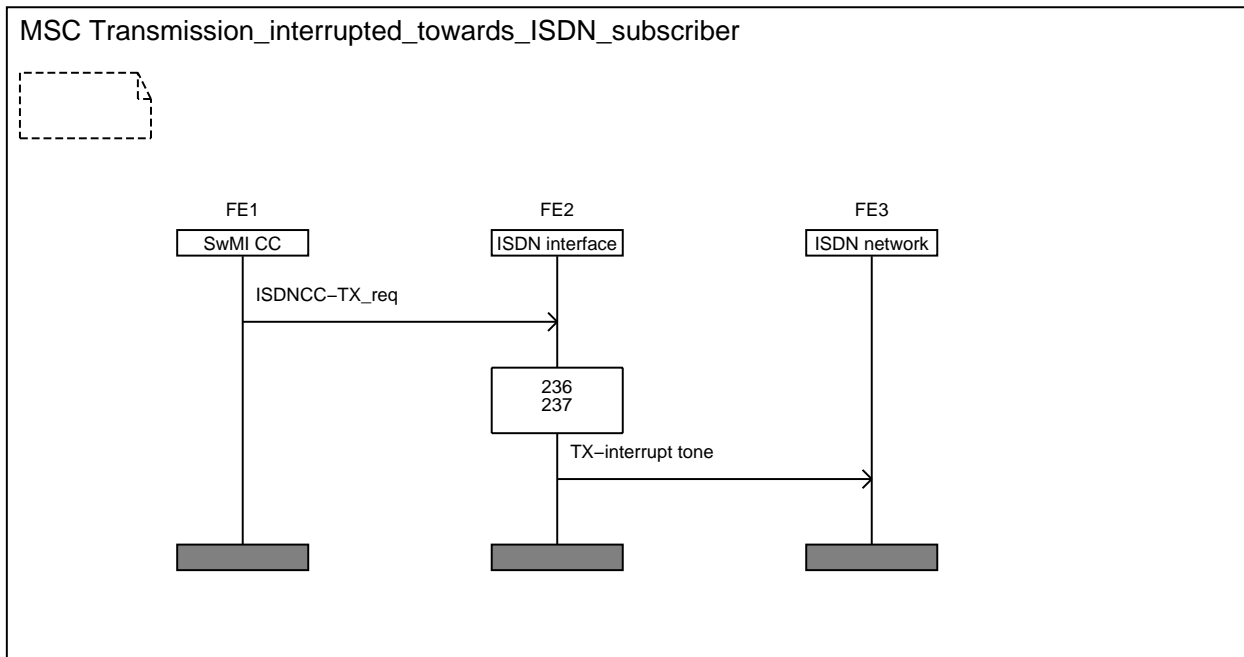

Figure 17: Information flow sequence - interrupt of transmitting ISDN subscriber

5.2.1.9 Call maintenance procedures - Withdrawal of transmission in the gateway SwMI

If the SwMI call control application wishes to withdraw transmission due to the fact that resources are required for another call or when the SwMI call control application requires that the call should temporarily be paused, the ISDN subscriber shall be informed via a queuing tone as for the PSTN gateway ETS 300 392-4-1 [14].

If the ISDN subscriber is transmitting when the SwMI wishes to withdraw transmission, transmission interruption shall first be applied as described in subclause 5.2.1.8.

5.2.1.10 Call disconnection procedures - Request to disconnect from a TETRA user or TETRA SwMI

Figure 18 shows a request to disconnect from the controlling or other end SwMI. The complete call is to be disconnected.

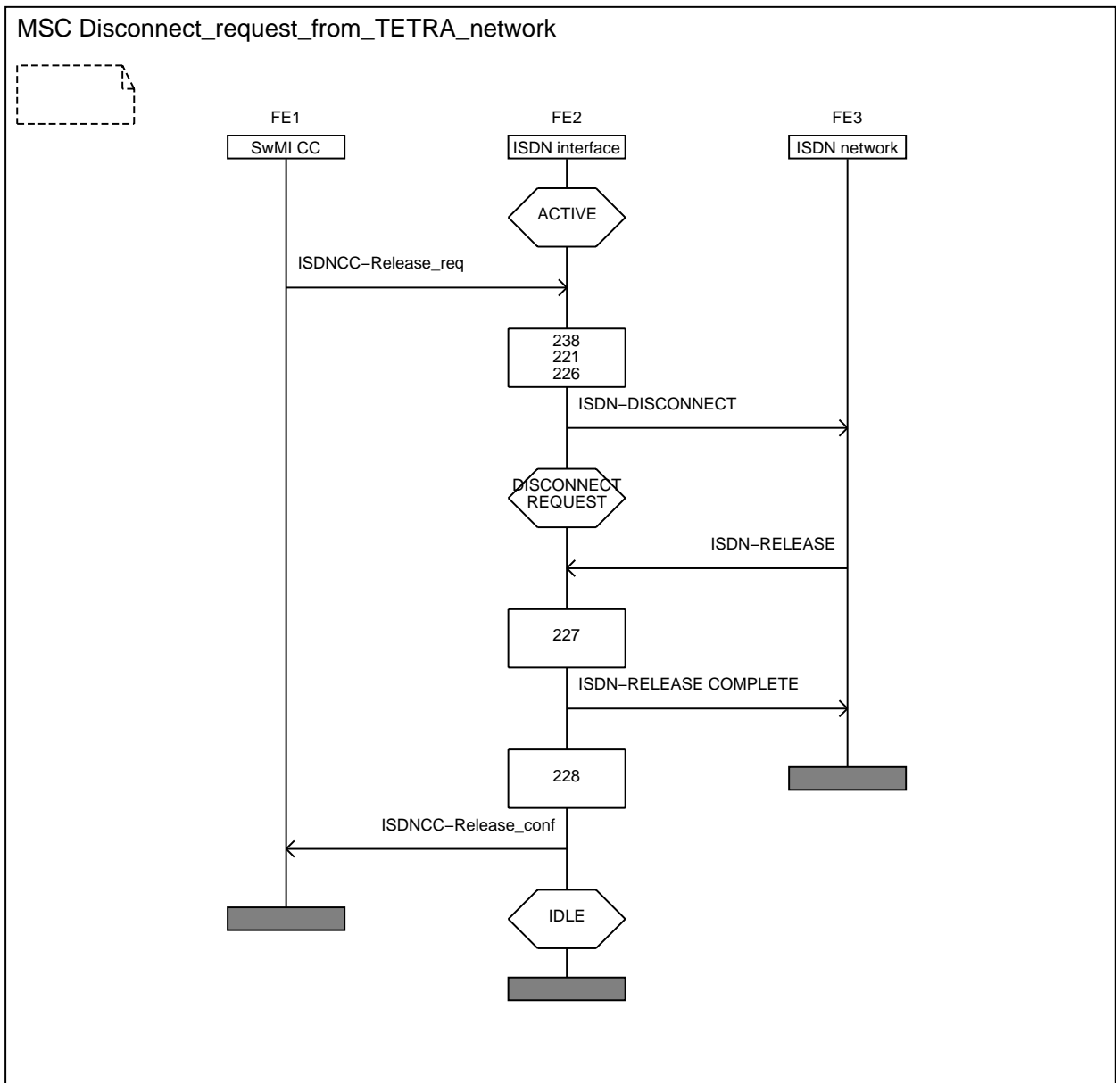

Figure 18: Information flow sequence - request to disconnect from a TETRA user or TETRA SwMI

5.2.1.11 Call disconnection procedures - Request to disconnect from the ISDN network

Figure 19 shows a request to disconnect from the ISDN network. For a group call the controlling SwMI may decide to continue the call without the ISDN subscriber.

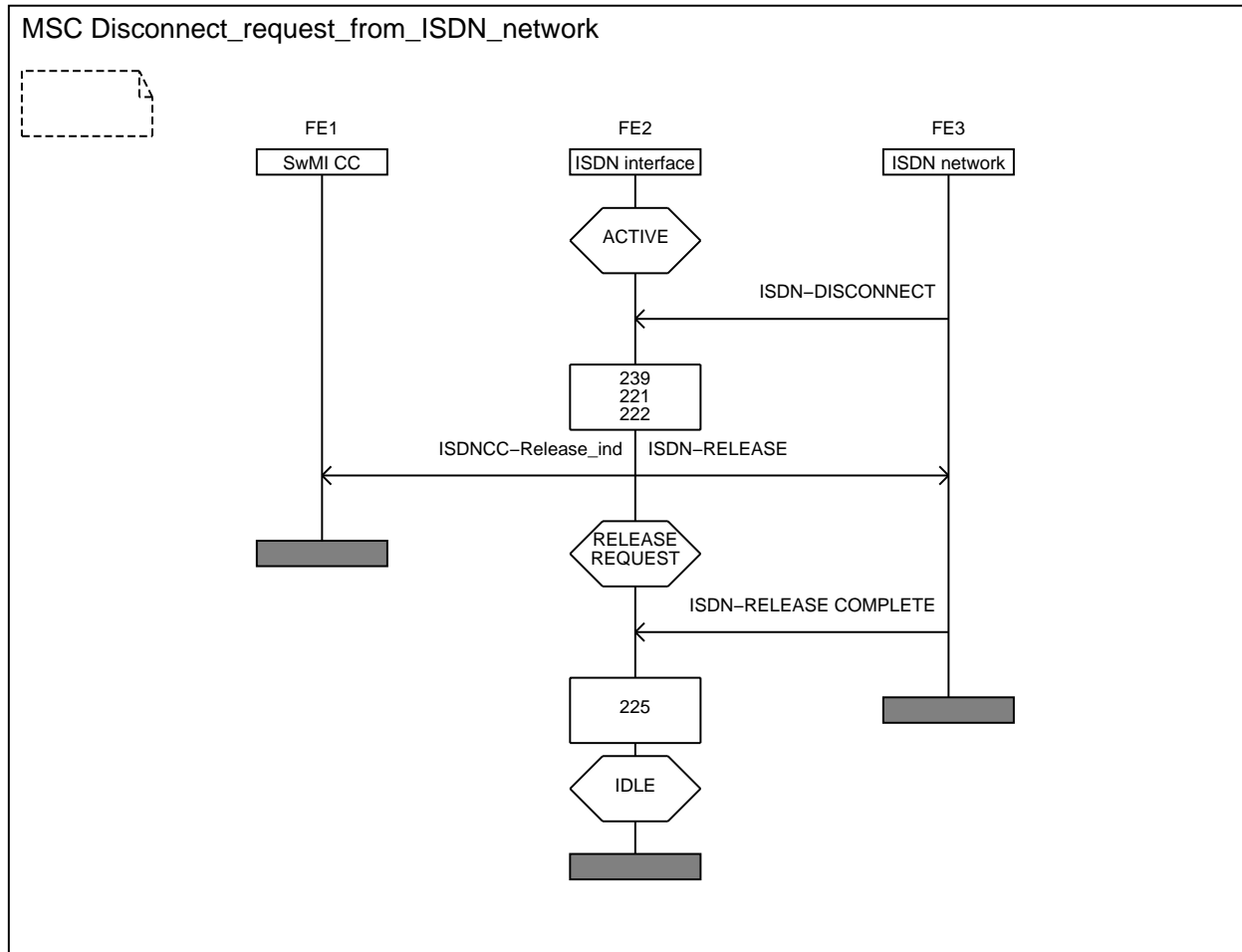

Figure 19: Information flow sequence - request to disconnect from an ISDN subscriber

5.3 Functional Entity Actions (FEAs)

The following FE actions shall occur at the points indicated in figures in subclause 5.2.1.

NOTE: In an individual call the controlling SwMI is collocated with the originating SwMI.

5.3.1 Functional entity actions of FE2

- 201 Outgoing individual or group call is to be set-up. The external subscriber is defined by the information element 'external subscriber number'.
- 202 Map the TETRA PDU to an ISDN SETUP message. Send the ISDN SETUP en-bloc to the ISDN network with the complete ISDN subscriber number.
- 203 Check if B-channel indicated in the information element 'channel identification' can be accepted. If so attach B-channel.
- 204 Inform FE1 of call processing.
- 205 The called user is being alerted. Inform FE1.
- 206 The call has been accepted by the called ISDN subscriber. Inform FE1 of connection.

- 207 Incoming call is to be set-up. The external subscriber may be identified by the information element 'calling party number' and 'calling party subaddress'. The TETRA user or group is identified by the information element 'called party number' and possible the 'called party subaddress' information element.
- 208 Incoming call is to be set-up. The external subscriber may be identified by the information element 'calling party number' and 'calling party subaddress'. The TETRA user or group address has not been received. Two stage dialling is to be performed.
- 209 If an alternative B-channel may be indicated and the given B-channel is not acceptable, indicate new alternative.
- 210 Map the ISDN SETUP message to a TETRA primitive. Forward the TETRA primitive to FE1.
- 211 Inform the ISDN network that call set-up shall proceed in-band.
- 212 The called party number has been received as DTMF digits in-band. Map the received digits into the 'called party address information element in a TETRA set-up primitive. Forward the TETRA primitive to FE1.
- 213 The called user is being alerted. Map TETRA primitive to ISDN ALERTING message or send alert tone in-band.
- 214 The call set-up request has been queued. Send alerting message to ISDN network.
- 215 Participating SwMIs are being alerted. Map TETRA primitive to ISDN ALERTING message or send alert tone in-band.
- 216 Send an ISDN ALERTING message to the ISDN network.
- 217 ISDN ALERTING has already been sent. No actions shall be taken.
- 218 The called user has accepted the call or group members are being connected. Map TETRA primitive to ISDN CONNECT message or send TX-grant tone in-band if the call is a semi-duplex call.
- 219 Inform the ISDN network that the call is connected.
- 220 ISDN CONNECT ACKNOWLEDGE received. Connect confirmed by ISDN network, circuit switched connection complete. Go to the ACTIVE state.
- 221 Disconnect the B-channel.
- 222 Send the ISDN RELEASE message to the ISDN network.
- 223 The called user is busy. Map ISDN DISCONNECT message to TETRA primitive.
- 224 The ISDN network has initiated call clearing. Inform FE1 of the clearing request.
- 225 Release B-channel. The call no longer exists.
- 226 The call could not be connected. Map TETRA primitive to ISDN DISCONNECT message.
- 227 Send the ISDN DISCONNECT message to the ISDN network with an appropriate clearing cause.
- 228 Release the B-channel and send an ISDN RELEASE COMPLETE message to the ISDN network. The call no longer exists.
- 229 Inform FE1 that the call has been released towards the ISDN network.
- 230 The new B-channel could not be accepted by the ISDN network.
- 231 An ISDN subscriber wishes to transmit. Convert transmission request to a TETRA primitive.

- 232 Forward transmission request to FE1.
- 233 Transmission has been granted to the ISDN subscriber.
- 234 The ISDN subscriber has ceased transmission. Convert cease of transmission indication to a TETRA primitive.
- 235 Forward cease of transmission indication to FE1.
- 236 A TETRA user has been granted transmission. The ISDN subscriber is interrupted.
- 237 Inform ISDN subscriber of interruption.
- 238 FE1 has requested to clear the call. Map TETRA primitive to ISDN DISCONNECT message.
- 239 The ISDN network has initiated call clearing. Map ISDN DISCONNECT message to TETRA primitive. Inform FE1 of the clearing request.

6 ISDN gateway stage 3 specification

6.1 Protocol structure and protocol stack

Figure 20 shows the protocol stack of the ISDN gateway. The signalling between SwMI and ISDN shall use ISDN signalling as specified in EN 300 403-1 [9] or relevant national requirements not covered by these standards. The information exchange between SwMI and the ISDN subscriber shall use ISDN basic call signalling or DTMF signalling. This ETS is only normative for the signalling protocol architecture and signalling between an ISDN subscriber and TETRA SwMI, but gives an informative description of the protocol and the SAPs within the SwMI.

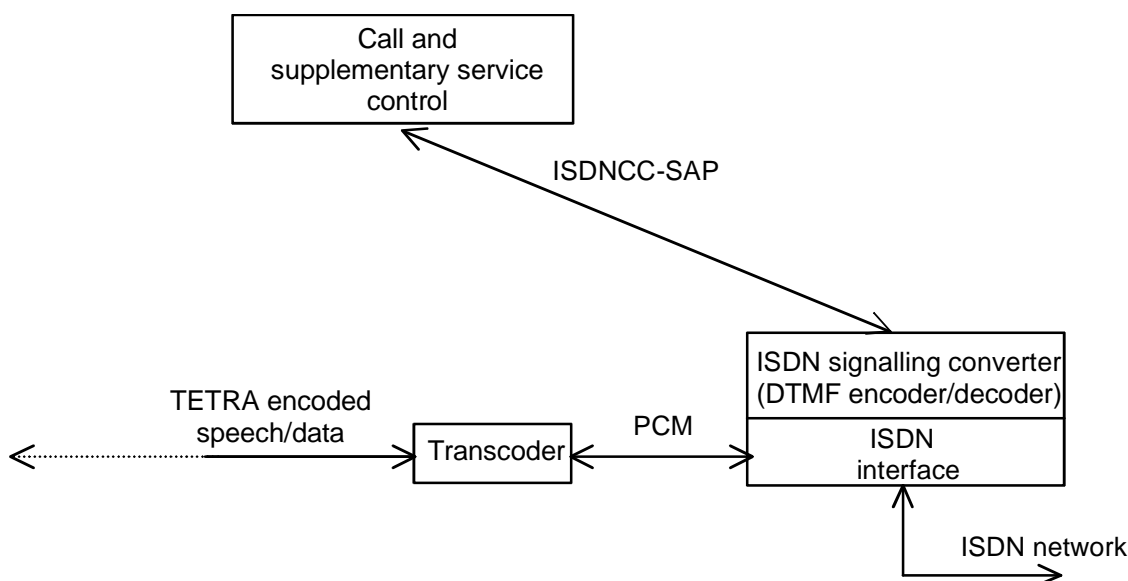

Figure 20: ISDN gateway protocol stack

6.2 TETRA gateway coding requirements

The messages between the ISDN gateway and an ISDN network shall be ISDN messages or sequences of DTMF tones if no ISDN message is applicable. The two stage dialing and transmission signalling has been described in subclauses 6.2.2 and 6.2.1. ISDN signalling messages have been defined in the standards, EN 300 403-1 [9] or relevant national requirements not covered by these standards.

The following subclauses are informative and only describes a few implementation options.

6.2.1 Non end-to-end ISDN calls

When interworking has occurred with non ISDN networks, call set-up signalling information sent to the TETRA gateway is sent in-band when indicated by the progress indicator. The ISDN gateway shall therefore follow call set-up procedures as described for the PSTN gateway ETS 300 392-4-1 [14] and EN 300 403-1 [9]. In addition the following call set-up guidance tones shall be supported.

6.2.1.1 Alert tone

See ISDN standards ETS 300 085 [10] or relevant national requirements not covered by this standard, for the alert tone sent by the ISDN gateway.

See the TETRA standard ETS 300 392-4-1 [14], annex D for TETRA recommended guidance tones.

6.2.1.2 Busy tone

See ISDN standards ETS 300 085 [10] or relevant national requirements not covered by this standard, for the busy tone sent by the ISDN gateway.

See the TETRA standard ETS 300 392-4-1 [14], annex D for TETRA recommended guidance tones.

6.2.1.3 Disconnect tone

See ISDN standards ETS 300 085 [10] or relevant national requirements not covered by this standard, for the disconnect tone sent by the ISDN gateway.

See the TETRA standard ETS 300 392-4-1 [14], annex D for TETRA recommended guidance tones.

6.2.1.4 Invalid number tone

See ISDN standards ETS 300 085 [10] or relevant national requirements not covered by this standard, for the invalid number tone sent by the ISDN gateway.

See the TETRA standard ETS 300 392-4-1 [14], annex D for TETRA recommended guidance tones.

6.2.2 Two stage dialling

6.2.2.1 Dialling Tone

See ISDN standards ETS 300 085 [10] or relevant national requirements not covered by this standard, for the dialling tone sent by the ISDN gateway.

See the TETRA standard ETS 300 392-4-1 [14], annex D for TETRA recommended guidance tones.

6.2.2.2 Dialling

For incoming calls the second set of the two stage dialling consists of a sequence of DTMF digits representing the dialed TETRA user number. The ISDN subscriber shall use DTMF signalling for the second set of the two stage dialling either using a telephone set equipped with a DTMF generator or any external DTMF generating device. The TETRA gateway shall receive the same DTMF tone and pause lengths as defined in I-ETS 300 245-1 [25] or relevant national requirement not covered by this standard.

If the complete ITSI or GTSI is not dialed, i.e. only the SSI, then the dialed number shall be ended with the # digit to indicate number complete.

6.2.2.3 Call set-up tones sent in-band

Call set-up signalling will occur in-band for two stage dialling. The guidance tones as described in subclause 6.2.1, 'Non end-to-end ISDN calls' shall therefore be supported.

6.2.3 Call set-up queuing

6.2.3.1 TETRA queuing tone

Indication sent to the ISDN subscriber that the call set-up has been queued by the TETRA SwMI. See the TETRA standard ETS 300 392-4-1 [14], annex D for TETRA recommended guidance tones.

6.2.4 Transmission signalling

6.2.4.1 User-to-User Signalling

The User-to-User Signalling supplementary service message USER INFORMATION may be used for transmission request and cease of transmission when the User-to-User Signalling supplementary service is supported by the ISDN subscriber and the ISDN gateway interface entity. See EN 300 286-1 [7] for the USER INFORMATION message description.

The following table defines request and cease request sent by an ISDN subscriber in the 'user information' field of the user-user information element.

Table 6: User Information field of the user-user information element

Length	Value	IA5 characters	Remark
8		*759	Normal priority transmission request
		#759	Transmission ceased

The above information shall be sent as IA5 characters.

6.2.4.2 DTMF signalling

When DTMF signalling is used to indicate transmission request and cease, the following DTMF digits shall be transmitted in-band between the ISDN subscriber and the ISDN gateway interface entity:

Table 7: Transmission signalling

Length	Digits	Remark
4	*759	Normal priority transmission request
	*752	High priority transmission request
	*751	Pre-emptive priority transmission request
	*750	Emergency priority transmission request
	#759	Transmission ceased

6.2.4.3 Guidance tones

6.2.4.3.1 TX-ceased tone

Indication sent to the ISDN subscriber that the talking party has ceased to talk. See the TETRA standard ETS 300 392-4-1 [14], annex D for TETRA recommended guidance tones.

6.2.4.3.2 TX-granted tone

Indication sent to the ISDN subscriber. This tone has two variants to indicate to whom the permission to talk is granted to, i.e. permission granted to ISDN subscriber or permission granted to another user. See the TETRA standard ETS 300 392-4-1 [14], annex D for TETRA recommended guidance tones.

6.2.4.3.3 TX-interrupt tone

Indication sent to the ISDN subscriber that permission to talk has been withdrawn. See the TETRA standard ETS 300 392-4-1 [14], annex D for TETRA recommended guidance tones.

6.2.5 DTMF signalling during ACTIVE state

6.2.5.1 From ISDN network

Any DTMF tones received from the ISDN network during the ACTIVE call state shall be mapped by the TETRA gateway interface entity into DTMF digits according to ETS 300 392-2 [12].

NOTE: See in I-ETS 300 245-1 [25] or relevant national requirement not covered by this standard for definition of DTMF tone and pause lengths.

6.2.5.2 From TETRA network

All DTMF digits sent from the TETRA call control application shall be mapped by the TETRA gateway interface entity into DTMF tones according to I-ETS 300 245-1 [25] or relevant national requirement not covered by this standard.

NOTE: See in ETS 300 392-2 [12] for DTMF digit definitions.

6.3 TETRA gateway state definitions

ISDN state definitions for the users side defined in the standards, EN 300 403-1 [9] or relevant national requirements not covered by these standards shall apply for the ISDN interface entity.

However, two extra states are needed when two stage dialing is performed. These states are the COLLECT DIGITS state and the WAIT ANSWER state. From IDLE the ISDN gateway interface entity may go to the COLLECT DIGITS state for incoming calls if it is determined that two stage dialing is needed. The state change occurs when sending the new dial tone in-band to the ISDN network.

The ISDN gateway interface entity shall remain in this state until all digits have been received. Upon collection of all dialed digits, the ISDN gateway interface entity shall send a TETRA set-up request to the SwMI call control application and then go to state WAIT ANSWER.

Once the TETRA user or users have answered the call, the ISDN gateway interface entity shall proceed to state ACTIVE.

6.4 TETRA gateway signalling procedures

The SDL representation showing the behaviour of the ISDN gateway interface entity is shown in figure A.1 to A.7 of annex A.

6.4.1 Call set-up procedures

6.4.1.1 Incoming calls

Upon reception of the ISDN SETUP message the ISDN gateway interface entity shall perform incoming call set-up procedures as described in the standards, EN 300 403-1 [9] or relevant national requirements not covered by these standards.

If the incoming call could be accepted by the ISDN gateway interface entity, a TETRA gateway SETUP primitive shall be sent to the SwMI call control application for further call set-up procedures.

The called TETRA user or group may be indicated in the ISDN SETUP message either:

- by the 'called party number' information element of the ISDN SETUP message; or
- by the 'called party number' and 'called party subaddress' information element of the ISDN SETUP message.

If the 'called party number' information element in the ISDN SETUP message is not the external ISDN number for the TETRA ISDN gateway due to invocation of SS-DDI, then the 'called party number' shall be mapped into the 'called external subscriber number' of the TETRA gateway SETUP primitive when ISDN SS-DDI for incoming calls is supported.

When the 'called party subaddress' information element has been received in the ISDN SETUP message due to invocation of SS-SUB, then this element shall be mapped into the 'called party address' of the TETRA gateway SETUP primitive. This element shall be used by the SwMI call control application to route the call to an individual or group and to determine which home network the individual or group belongs to.

If no 'called party subaddress' information element has been included in the ISDN SETUP message and the 'called party number' information element message is the external ISDN number for the TETRA ISDN gateway, then two stage dialling shall be initiated.

6.4.1.1.1 Two stage dialling

To initiate two stage dialling the ISDN gateway interface entity shall send an ISDN CONNECT message containing the progress indicator information element to the ISDN network when sufficient call set-up information has been received, i.e. response to en-bloc ISDN SETUP or completion of overlap receiving. The progress indicator information element shall be set to #1 'Call is not end-to-end ISDN; further call progress information may be available'. A new dial tone shall then be sent in-band from the TETRA gateway interface entity towards the ISDN network.

The ISDN gateway interface entity shall receive the called party number in-band as DTMF digits from the calling ISDN subscriber. The received DTMF digits shall be mapped into the 'called party address' of the TETRA gateway SETUP primitive.

NOTE: All following call set-up signalling will occur in-band.

6.4.1.1.2 Acknowledged group calls

An acknowledged group call initiated by the ISDN subscriber is not supported by this ETS.

6.4.1.1.3 Broadcast calls

A broadcast call initiated by the ISDN subscriber is not supported by this ETS.

6.4.1.1.4 Call priority

It may be possible for an ISDN subscriber to initiate priority calls by invoking the TETRA supplementary services Priority and Pre-emptive Priority call by employing the Service Code Command Format (SCCF) as described in ETS 300 738 [23] (See annex E for further information). However, supplementary service signalling interactions are outside the scope of this ETS.

It shall be an implementation matter which priority, if any, an incoming call from an ISDN subscriber shall receive when TETRA SS-PC and TETRA SS-PPC is not supported by the ISDN gateway.

6.4.1.2 Outgoing calls

Upon reception of an TETRA gateway SETUP primitive from the SwMI call control application the ISDN gateway interface entity shall map the called external subscriber number into the 'called party number' information element of the ISDN SETUP message. If available, the calling external subscriber number of the TETRA user or group shall be mapped into the 'calling party number' information element of the ISDN SETUP message otherwise the external number for the ISDN gateway shall be sent in the 'calling party number' information element.

Outgoing ISDN call set-up procedures shall then be performed as described in the standards, EN 300 403-1 [9] or relevant national requirements not covered by these standards.

The TETRA parameters simplex/duplex selection shall be used by the ISDN gateway interface entity to determine whether transmission request, grant and cease procedures shall be active during the call.

6.4.1.2.1 Two stage dialling

Not applicable for outgoing calls.

6.4.1.2.2 Acknowledged group calls

An ISDN subscriber may participate in an acknowledged group call initiated by a TETRA user. The SwMI call control application should consider the TETRA gateway COMPLETE or RELEASE primitive sent from the ISDN gateway interface entity as a polling response.

6.4.1.2.3 Broadcast calls

No indication has been standardized to that can be sent to the ISDN subscriber to indicate that a broadcast call has been initiated. Seen for the external subscriber, the call shall resemble a group call. However, it shall not be possible for the external subscriber to receive grant of transmission.

6.4.1.3 Colliding calls

Call collisions as such cannot occur at the TETRA gateway. Any simultaneous incoming or outgoing calls are dealt with separately and assigned different call references. See EN 300 403-1 [9] for further details.

6.4.1.4 Unsuccessful call set-up

Unsuccessful call set-up procedures at the ISDN gateway interface entity shall be performed according to the standards, EN 300 403-1 [9] or relevant national requirements not covered by these standards.

6.4.2 Call maintenance procedures

When an individual call is set-up in a semi-duplex mode or a group call is active, transmission request and granting shall be required. In the following subclauses three different methods for signalling transmission request and responses through an ISDN gateway have been defined. One of the following methods may be supported for transmission request and granting, e.g.:

- voice activity detection;
- the supplementary service user-to-user information signalling; and
- in-band signalling using DTMF signals.

NOTE 1: Simplex duplex selection is indicated in the TETRA gateway SETUP primitive for outgoing calls and in the TETRA gateway COMPLETE primitive for incoming calls.

The parameters transmission request permission and transmission grant sent from the SwMI call control application shall be used to indicate whether the ISDN subscriber may request for transmission (e.g. this could be a broadcast call and therefore the ISDN subscriber shall not receive transmission permission) and whether a transmission request has been granted or not.

In addition the following rules should be applied when an ISDN subscriber is participating in a semi-duplex individual call or only one ISDN subscriber is participating in a group call.

To ensure that the ISDN subscriber can received transmission grant before starting to speak, transmission should always be granted to this user when no TETRA individual is transmitting. Therefore, when the SwMI call control application receives a TX CEASED PDU, it should always respond with a TX GRANTED PDU to either queued request from TETRA users or to the ISDN subscriber.

NOTE 2: Transmission should always be granted to requesting TETRA users before granting transmission to the ISDN subscriber.

If a TETRA user requests permission to transmit while the ISDN subscriber is transmitting, transmission should be interrupted towards the ISDN subscriber and transmission granted to the requesting TETRA user.

6.4.2.1 Transmission request

6.4.2.1.1 Voice activity detection

A voice activity detector (VAD) may be used when an individual semi-duplex call exist between an ISDN subscriber and a TETRA user.

NOTE 1: The connection between the ISDN subscriber, the ISDN network and the TETRA ISDN gateway is a duplex connection.

For group calls a VAD should only be used when group members are individually addressed through the ISDN gateway.

NOTE 2: It is not recommended to use a VAD when group members are connected to the group call through a conference switch outside the TETRA ISDN gateway. This is due to the fact, that the ISDN gateway is considered a conference member in the external conference switch and each member in the conference call are connected together in a duplex connection. Once transmission has been granted to an external group member the transmission grant will remain with the external group members as long as one of the them are speaking.

Upon voice activity detection from a external subscriber the ISDN gateway interface entity shall send a TETRA transmission request (TETRA gateway TX primitive) to the SwMI call control application, indicating which external subscriber has requested transmission.

6.4.2.1.2 User-to-user signalling

When the call is end-to-end ISDN the supplementary service user-to-user information may be used if the ISDN subscriber(s) supports user-to-user signalling. User-to-user signalling service 3 shall then be used by the external subscriber(s) when requesting transmission in a semi-duplex call with a TETRA user or group.

For outgoing call set-up request the user-to-user service 3 shall be requested during call set-up by the TETRA ISDN gateway interface entity. For incoming call set-up request the service may be requested during call set-up by the ISDN subscriber. However, if not requested by the calling ISDN subscriber, the ISDN gateway interface entity shall invoke user-to-user service 3 after call set-up.

For group calls user-to-user signalling may be used when group members are individually addressed through the ISDN gateway or when group members are connected to the group call through a conference switch outside the TETRA ISDN gateway.

NOTE 1: The location of an external conference switch is outside this standard and has not been standardized for TETRA inter-connect calls through an ISDN gateway.

NOTE 2: See EN 300 403-1 [9] and EN 300 286-1 [7] for invocation procedures of the supplementary service user-to-user signalling.

NOTE 3: See annex B for group call set-up sequences where the calling and called group members are ISDN subscribers. User-to-user signalling service 3 is invoked for each external member participating in the group call.

When an external ISDN subscriber requests transmission, the ISDN USER INFORMATION message shall be sent to the ISDN gateway interface entity. For individual calls or individually addressed group members the ISDN gateway interface entity shall indicate to the SwMI call control application which external user has requested transmission.

The user information field of the user-to-user information element in the ISDN USER INFORMATION message shall be set to transmission requested as defined in table 6. The protocol discriminator of the user-to-user information element shall be set to IA5 characters.

6.4.2.1.3 DTMF signalling

When the call is not end-to-end ISDN or the ISDN subscriber does not support the supplementary service user-to-user information, in-band signalling may be used to request transmission in a semi-duplex call. A set of DTMF digits as defined in table 7 shall be sent to the TETRA ISDN gateway when an ISDN subscriber request to transmit.

A DTMF decoder located at the TETRA ISDN gateway interface shall interpret the received DTMF digits. The ISDN gateway interface entity shall then send a TETRA transmission request (TETRA gateway TX primitive) to the SwMI call control application, indicating which external subscriber has requested transmission.

For external group members connected to the TETRA ISDN gateway through a conference switch, no distinction can be made between the subscribers connected to the conference. Transmission granting shall occur to the external connection and not to an individual ISDN subscriber. Therefore, when transmission has been granted to the external connection each subscriber connected to the conference switch can transmit to TETRA group members.

NOTE 1: In contrary to voice activity detection, transmission will be ceased when the granted subscriber sends a DTMF digit indicating cease transmission regardless of whether the other subscribers connected to the conference switch are speaking.

NOTE 2: The location of an external conference switch is outside this standard and has not been standardized for TETRA inter-connect calls through an ISDN gateway.

DTMF signalling frequencies have been defined in I-ETS 300 245-1 [25].

6.4.2.2 Transmission request response

If permission to request for transmission is not given during call set-up, any transmission request received by the TETRA ISDN gateway interface entity from an ISDN subscriber shall be rejected, i.e. transmission not granted.

First upon reception of a TETRA gateway TX primitive sent from the SwMI call control application indicating that transmission may be requested, should the TETRA ISDN gateway interface entity send transmission request to the SwMI call control application.

A request to transmit from an ISDN subscriber may be queued. A queuing tone shall than be sent back to the ISDN subscriber.

6.4.2.2.1 Voice activity detection

A TX granting tone as described in subclause 6.2.2.3.2 may be sent in-band to the requesting ISDN subscriber. No other type of response shall be given to the requesting subscriber.

6.4.2.2.2 User-to-user signalling

The ISDN gateway interface entity shall inform the requesting ISDN subscriber of the transmission response received from the SwMI call control application by sending a TX granting tone as described in subclause 6.2.2.3.2.

User-to-user signalling may be used by the ISDN gateway application to send further transmission information to the ISDN subscriber, e.g. talking party identity. However, encoding of the user information field and presentation of such information to the ISDN subscriber is outside this standard.

6.4.2.2.3 DTMF signalling

The ISDN gateway interface entity shall inform the requesting ISDN subscriber of the transmission response received from the SwMI call control application by sending a TX granting tone as described in subclause 6.2.2.3.2.

6.4.2.3 End of transmission

6.4.2.3.1 Voice activity detection

Transmission shall be ceased for the talking ISDN subscriber when no speech has been received for a minimum of 15 seconds.

A TX cease tone as described in subclause 6.2.2.3.1 may be sent in-band to the ISDN subscriber when a TETRA gateway TX primitive has been received from the SwMI call control application indicating that the talking party has ceased to talk.

6.4.2.3.2 User-to-user signalling

When the talking ISDN subscriber wishes to cease transmission, the ISDN USER INFORMATION message shall be sent to the ISDN gateway interface entity. For individual calls or individually addressed group members the ISDN gateway interface entity shall indicate to the SwMI call control application which external user has ceased transmission.

The user information field of the user-to-user information element in the ISDN USER INFORMATION message shall be set to transmission ceased as defined in table 6.

A TX cease tone as described in subclause 6.2.2.3.1 shall be sent in-band to the ISDN subscriber when a TETRA gateway TX primitive has been received from the SwMI call control application indicating that the talking party has ceased to talk.

User-to-user signalling may be used by the ISDN gateway application to send further transmission information to the ISDN subscriber, e.g. talking party identity. However, encoding of the user information field and presentation of such information to the ISDN subscriber is outside this standard.

6.4.2.3.3 DTMF signalling

A set of DTMF digits as defined in table 7 shall be sent to the TETRA ISDN gateway when the talking ISDN subscriber wishes to cease transmission.

A TX cease tone as described in subclause 6.2.2.3.1 shall be sent in-band to the ISDN subscriber when a TETRA gateway TX primitive has been received from the SwMI call control application indicating that the talking party has ceased to talk.

6.4.2.4 Interruption of transmission

6.4.2.4.1 Voice activity detection

A TX interrupt tone as described in subclause 6.2.2.3.3 shall be sent in-band to the ISDN subscriber when a TETRA gateway TX primitive has been received from the SwMI call control application indicating that transmission is to be withdrawn from the talking ISDN subscriber.

6.4.2.4.2 User-to-user signalling

A TX interrupt tone as described in subclause 6.2.2.3.3 shall be sent in-band to the ISDN subscriber when a TETRA gateway TX primitive has been received from the SwMI call control application indicating that transmission is to be withdrawn from the talking ISDN subscriber.

User-to-user signalling may be used by the ISDN gateway application to send further transmission information to the ISDN subscriber, e.g. talking party identity. However, encoding of the user information field and presentation of such information to the ISDN subscriber is outside this standard.

6.4.2.4.3 DTMF signalling

A TX interrupt tone as described in subclause 6.2.2.3.3 shall be sent in-band to the ISDN subscriber when a TETRA gateway TX primitive has been received from the SwMI call control application indicating that transmission is to be withdrawn from the talking ISDN subscriber.

6.4.3 Call disconnection procedures

6.4.3.1 Disconnect initiated by TETRA user or TETRA SwMI

The ISDN gateway interface entity shall initiate ISDN disconnection procedures as described in the standards, EN 300 403-1 [9] or relevant national requirements not covered by these standards when requested by the SwMI call control application.

The SwMI call control application shall be informed of release completion towards the ISDN network.

See annex D for mapping between TETRA and ISDN disconnect causes.

6.4.3.2 Disconnection initiated by ISDN subscriber

The ISDN gateway interface entity shall perform ISDN release procedures as described in the standards, EN 300 403-1 [9] or relevant national requirements not covered by these standards when a clearing message has been received by the ISDN network.

The SwMI call control application shall be informed of the release procedures towards the ISDN network.

See annex D for mapping between ISDN and TETRA disconnect causes.

6.4.3.3 Colliding disconnection

Subclause 5.3.5 in EN 300 403-1 [9] shall be applicable.

6.5 Protocol interaction between TETRA gateway and TETRA supplementary services

All protocol interactions with TETRA supplementary services are described in the individual TETRA supplementary service standards.

6.6 Protocol interaction between TETRA gateway and ISDN supplementary services

All protocol interactions as identified in subclause 4.4 with ISDN supplementary services and other networks are described in the individual ISDN supplementary service standards.

6.7 TETRA gateway parameter values (timers)

ISDN timers for the users interface shall be defined as indicated in the standard EN 300 403-1 [9] or relevant national requirements not covered by these standards.

No extra TETRA timers are needed.

Annex A (normative): Specification and description Language (SDL) representation of procedures

The diagrams in this annex use the Specification and Description Language defined in ITU-T Recommendation Z.100 [31].

The diagrams represents the behaviour of the ISDN interface entity within a SwMI.

A.1 SDL representation of ISDN interface entity FE2

Figure A.1 shows the behaviour of the ISDN interface entity at the ISDN gateway SwMI.

The following conventions are used:

- the input signals from the left represent primitives from the SwMI call control application;
- the output signals to the left represent primitives to the SwMI call control application;
- the input signals from the right represent ISDN messages from the ISDN;
- the output signals to the right represent ISDN messages to the ISDN network.

All unexpected messages received from the ISDN network shall be handled as described in the standards, EN 300 403-1 [9] or relevant national requirements not covered by these standards.

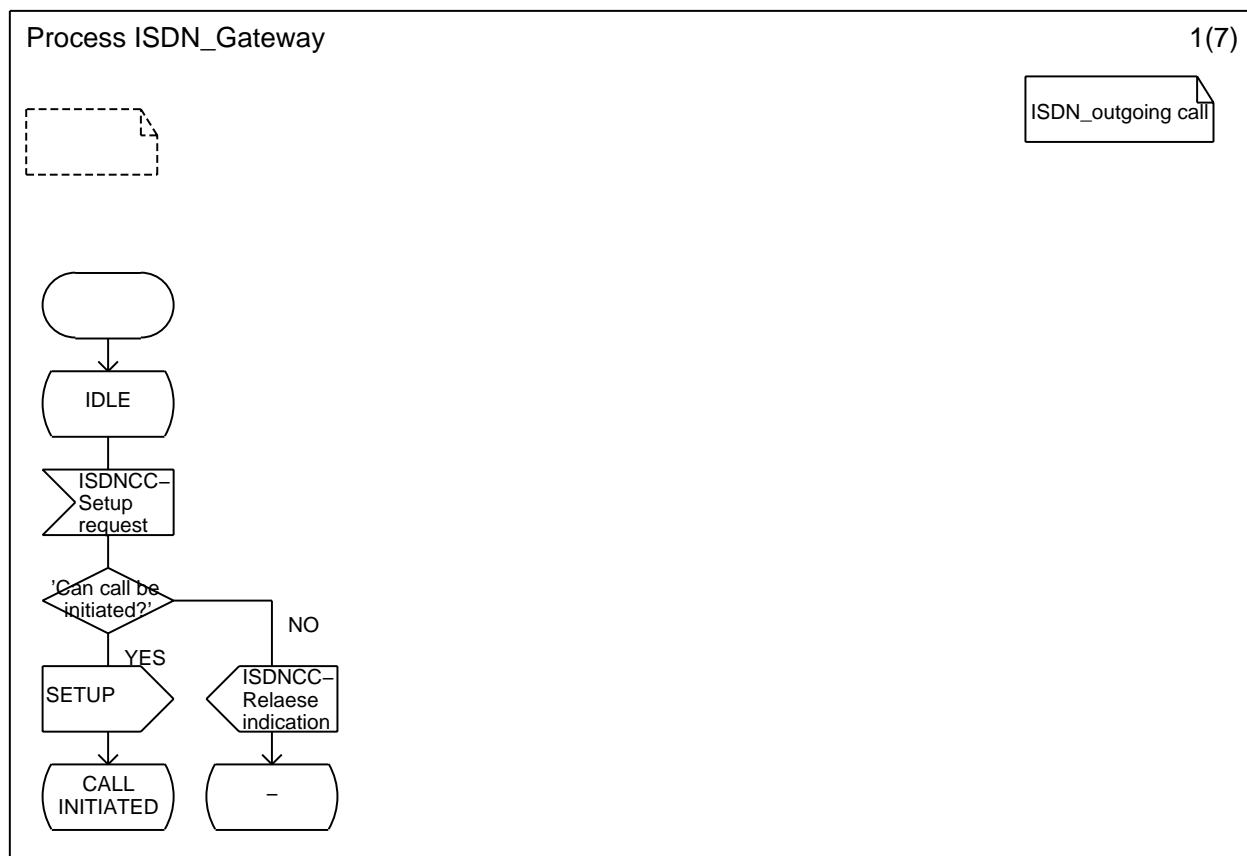

Figure A.1: SDL for ISDN gateway interface entity

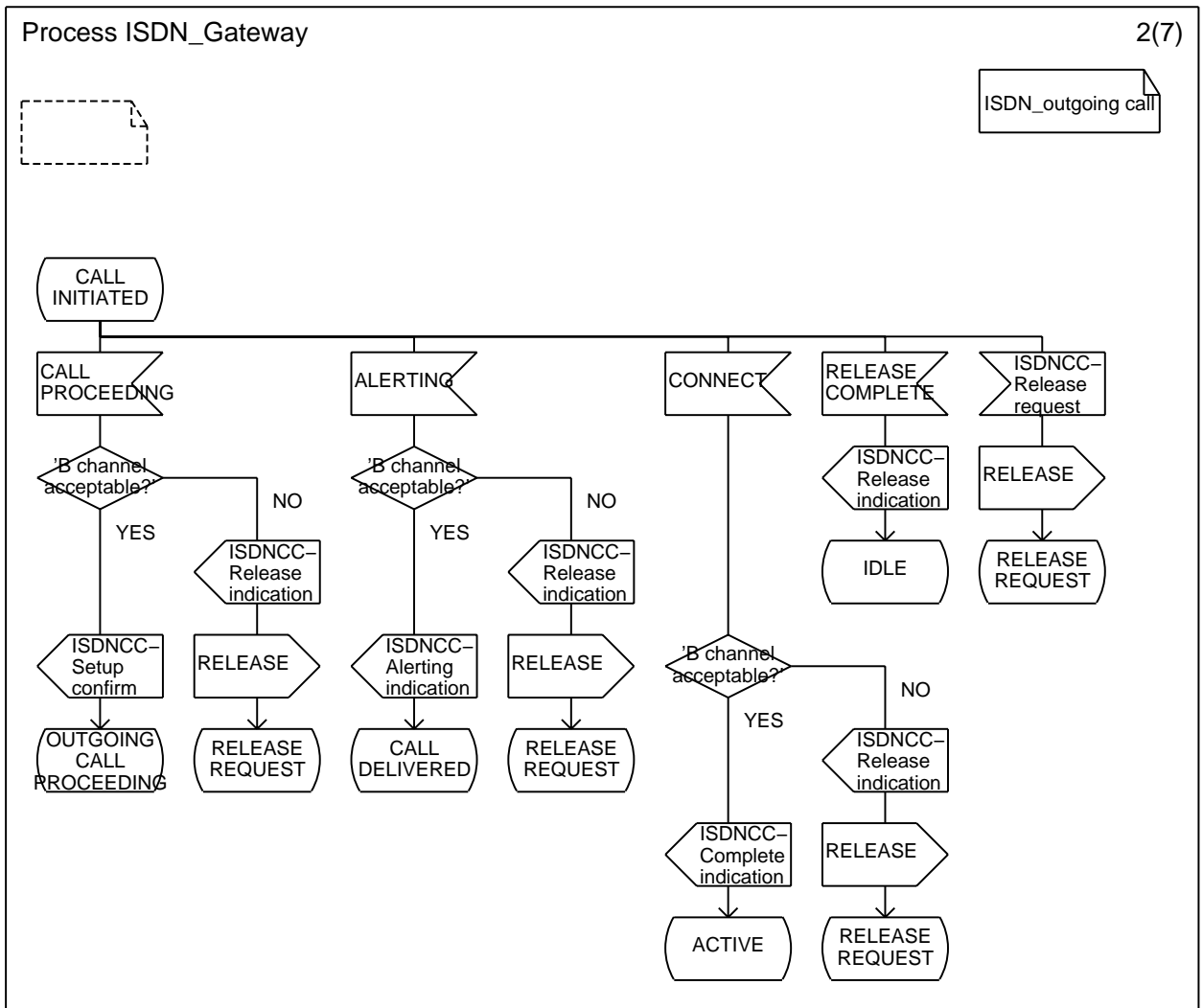

Figure A.2: SDL for ISDN gateway interface entity

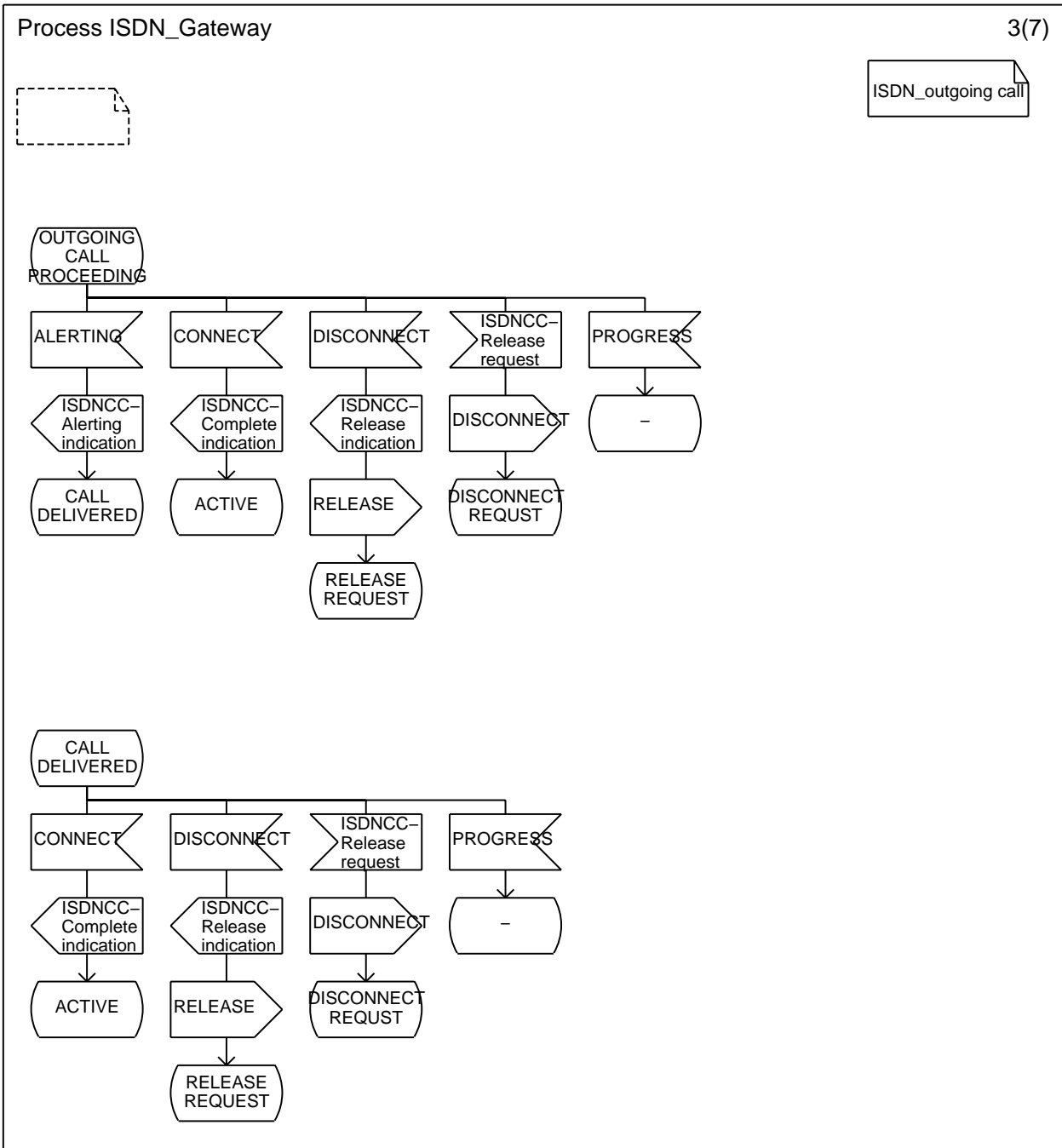

Figure A.3: SDL for ISDN gateway interface entity

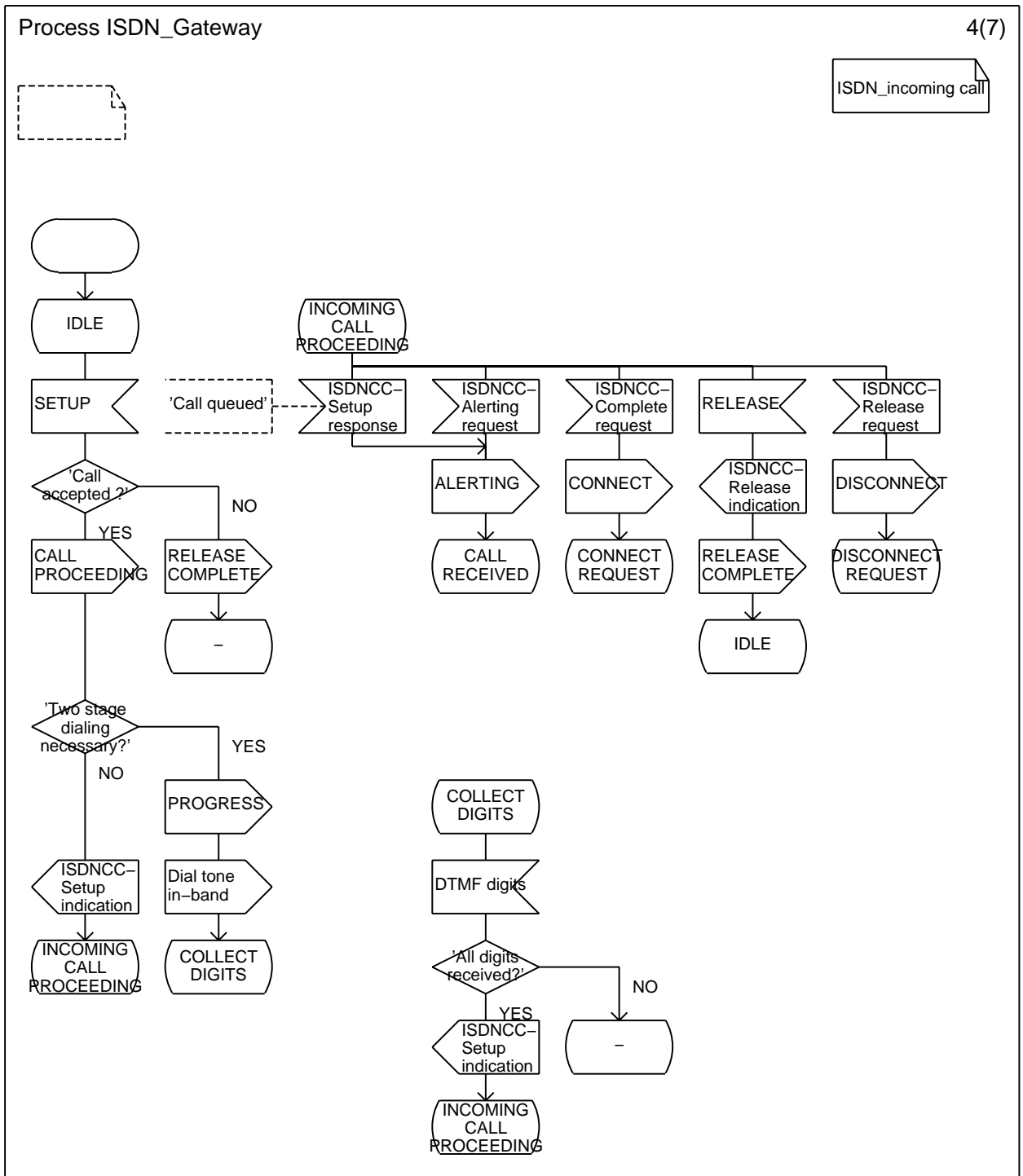

Figure A.4: SDL for ISDN gateway interface entity

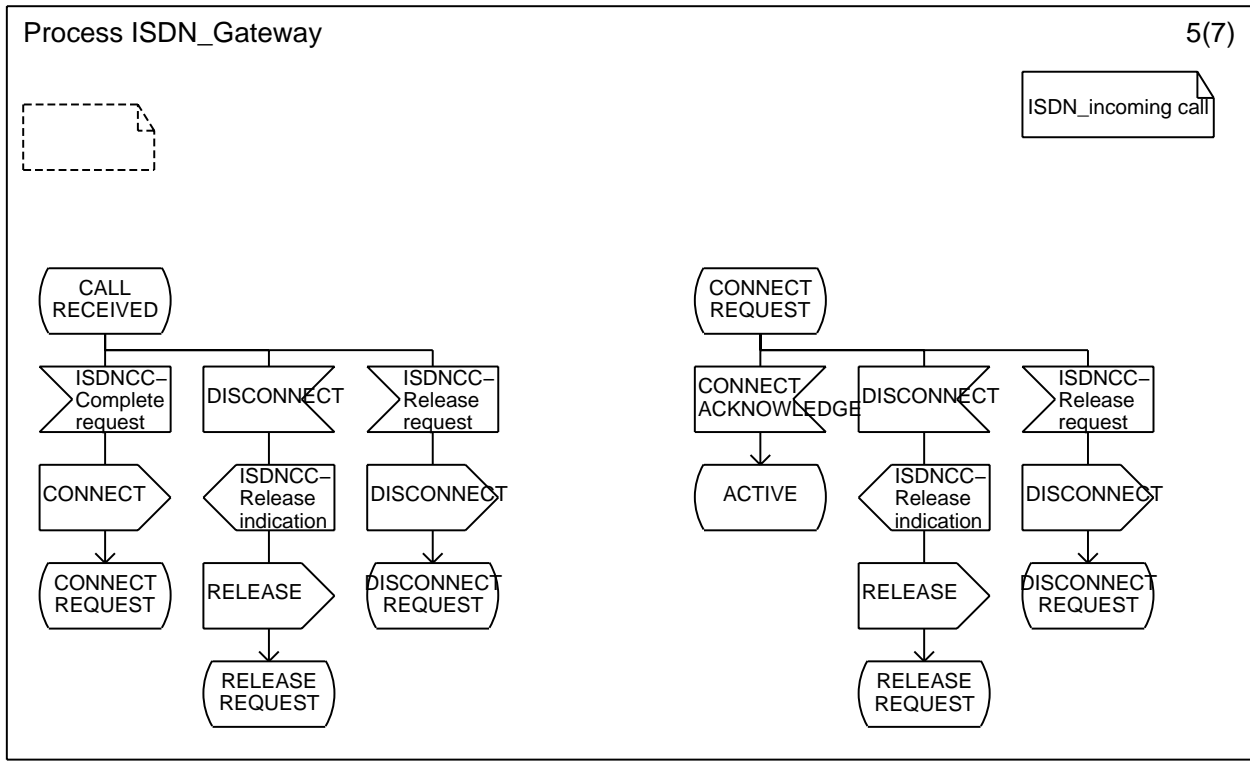

Figure A.5: SDL for ISDN gateway interface entity

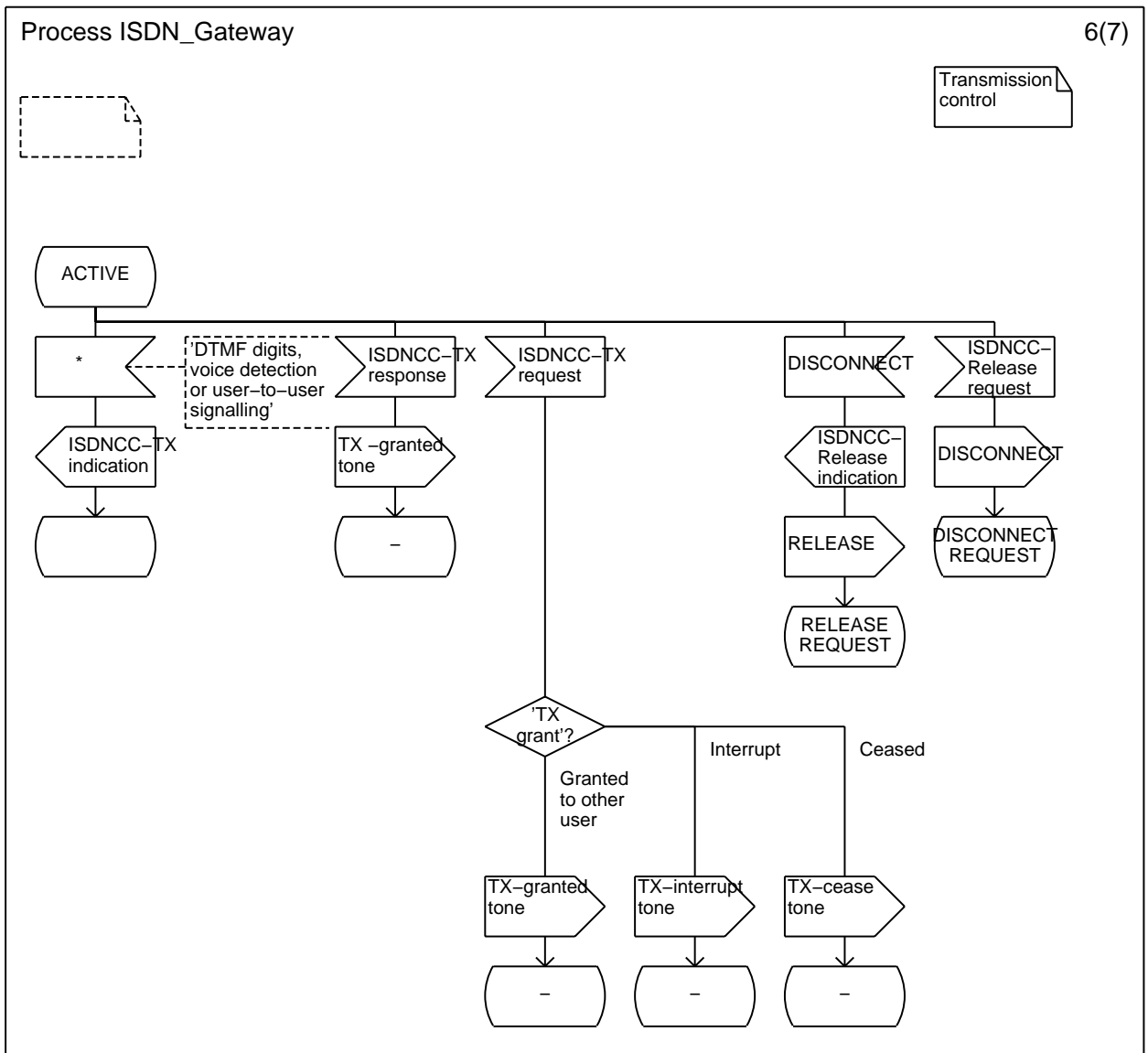

Figure A.6: SDL for ISDN gateway interface entity

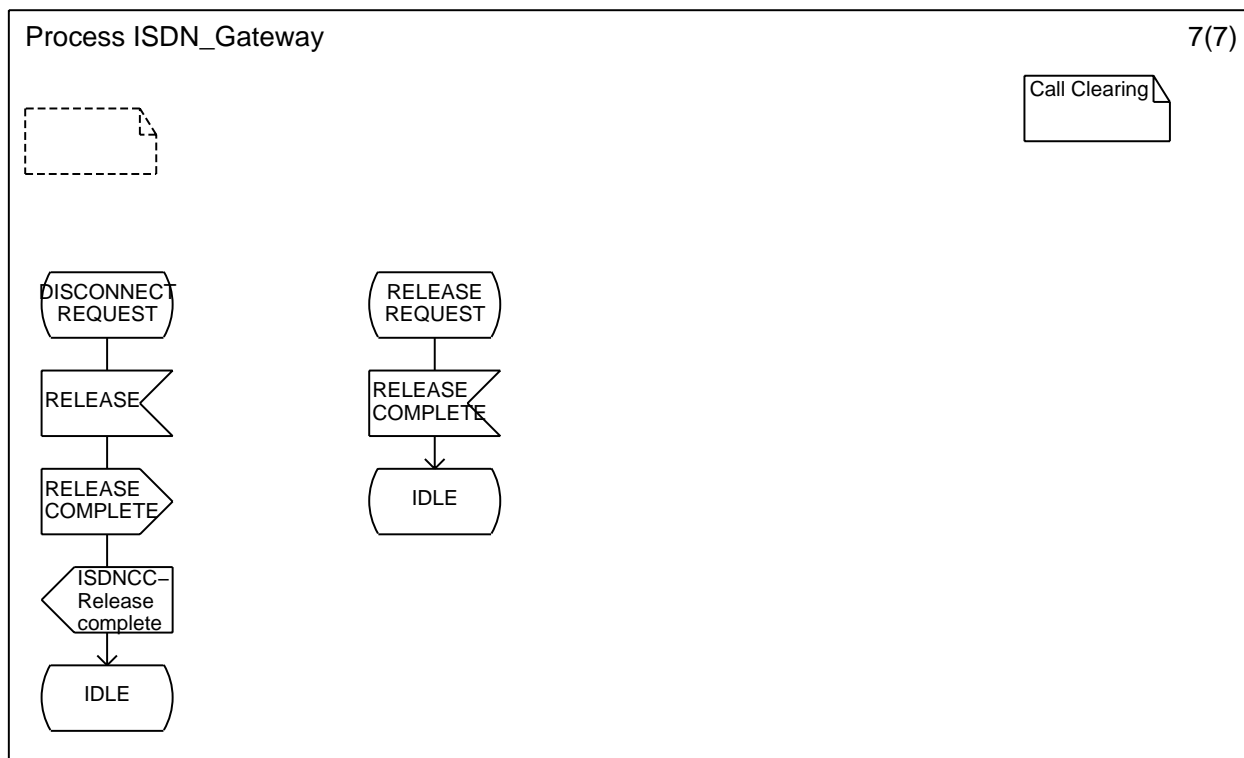

Figure A.7: SDL for ISDN gateway interface entity

Annex B (normative): TETRA group call set-up with external ISDN group members

B.1 User-to-user signalling service 3

The following shows how a group call can be set-up when external group members are individually addressed through the TETRA ISDN gateway.

The supplementary service user-to-user signalling has been invoked by the calling user during call set-up. User-to-user signalling service 3 (UUS3) is to be used for transmission requesting and granting.

The following requires that the ISDN subscribers and the TETRA ISDN gateway support the ISDN supplementary services User-to-User signalling service 3 (UUS3).

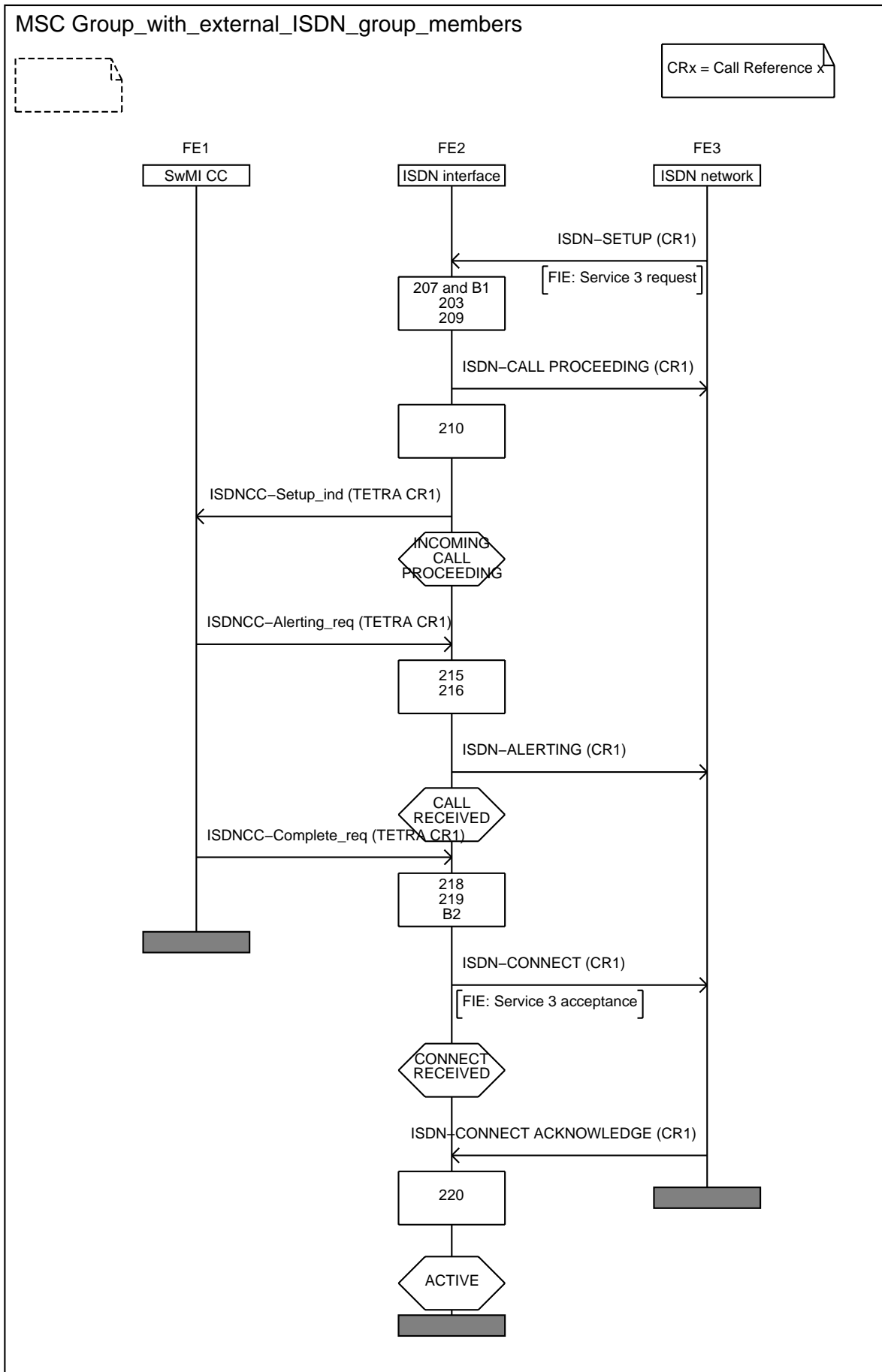

Figure B.1: Information flow sequence - TETRA Group call from ISDN with individually addressed external group members

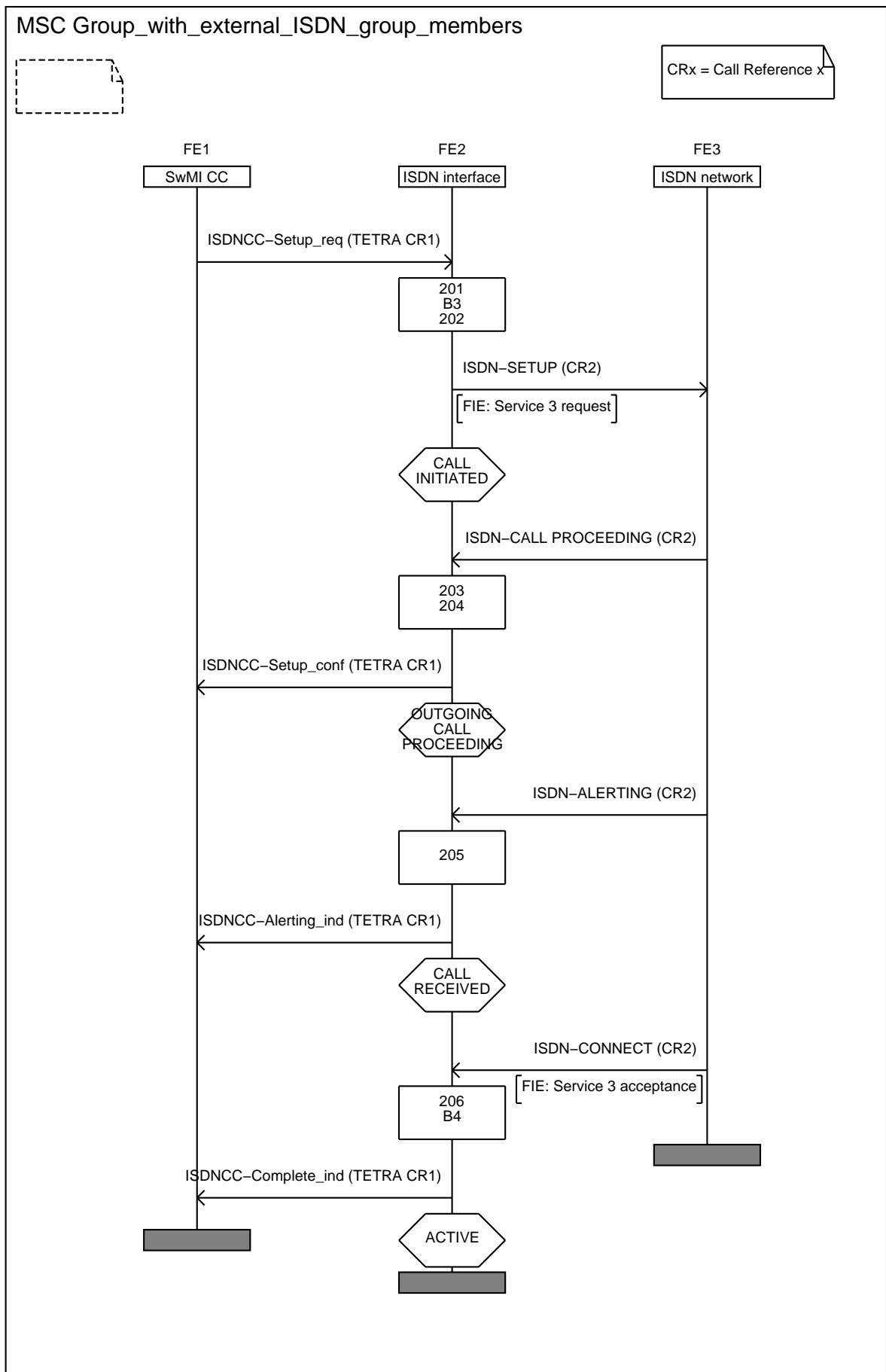

Figure B.2: Information flow sequence - TETRA Group call towards ISDN with individually addressed external group members

B.1.1 Functional Entity Actions (FEAs)

The following FE actions shall occur at the points indicated in the figures in annex B.

NOTE: In an individual call the controlling SwMI is collocated with the originating SwMI.

B.1.1.1 Functional entity actions of FE2

- B1 The calling ISDN subscriber has requested user-to-user signalling service 3.
- B2 User-to-user signalling service 3 has been accepted by the ISDN gateway.
- B3 User-to-user signalling service 3 has been invoked by the ISDN gateway. Send a request for user-to-user signalling service 3 in the ISDN-SETUP message to external group members.
- B4 User-to-user signalling service 3 has been accepted by the external group member.

Annex C (informative): Static description of the TETRA ISDN gateway bearer service, using attributes

Mapping of the bearer service information defined in ETS 300 392-2 [12] to ISDN bearer services leads to the static description of TETRA ISDN gateway bearer service attributes supported over ISDN. The bearer service attributes are given below using the relevant attributes with the corresponding values as defined in ITU-T Recommendation I.140 [29].

C.1 Information transfer attributes

- 1) Information transfer mode: "circuit" for TETRA speech teleservices.
- 2) Information transfer rate: "64 kbit/s" for TETRA speech teleservices.
- 3) Information transfer capability: "speech" for all TETRA speech teleservices.
- 4) Structure: for TETRA speech teleservices: "8 kHz integrity".
- 5) Establishment of communication: demand.
- 6) Symmetry: bi-directional symmetric.
- 7) Communication configuration: point-to-point.

C.2 Access attributes

- 1) Access channel and rate: Not applicable for circuit switched speech calls.
- 2) Access protocol: Recommendation G.711 [26] A-law.
- 3) Supplementary services provided: in line with ITU-T Recommendation I.210 [30], the definition of the value of this attribute is under study.
- 4) Quality of service: in line with ITU-T Recommendation I.210 [30], the definition of the value of this attribute is under study.
- 5) Interworking capability: according to ITU-T Recommendation I.140 [29], the possible values of this attribute remain to be defined.
- 6) Operational and commercial aspects: according to ITU-T Recommendation I.140 [29], the possible values of this attribute remain to be defined.

Annex D (informative): Mapping of TETRA disconnection causes to ISDN disconnection causes

D.1 Mapping of TETRA disconnect causes

The following table is only informative. The table is intended to be used as a guideline for mapping TETRA disconnection causes to ISDN disconnection causes. See table D.2 for mapping from a ISDN disconnection cause to a TETRA disconnection cause.

Table D.1: TETRA disconnect cause to ISDN disconnect cause

TETRA disconnect cause	ISDN disconnect cause
Cause #0 "Cause not defined or unknown "	Cause #31 "normal, unspecified"
Cause #1 "User requested disconnect"	Cause #16 "normal call clearing"
Cause #2 "Called party busy"	Cause #17 "user busy"
Cause #3 "Called party not reachable"	Cause #18 "no user responding"
Cause #4 "Called party does not support encryption"	Cause #127 "interworking, unspecified"
Cause #5 "Congestion in infrastructure"	Cause #47 "resource unavailable, unspecified"
Cause #6 "Not allowed traffic case"	Cause #63 "service or option not available "unspecified"
Cause #7 "Incompatible traffic case"	Cause #63 "service or option not available "unspecified"
Cause #8 "Requested service not available"	Cause #63 "service or option not available "unspecified"
Cause #9 "Pre-emptive use of resource"	Cause #47 "resource unavailable, unspecified"
Cause #10 "Invalid call identifier"	Cause #81 "invalid call reference value"
Cause #11 "Call rejected by the called party"	Cause #21 "call rejected"
Cause #12 "No idle CC entity"	Cause #47 "resource unavailable, unspecified"
Cause #13 "Expiry of timer"	Cause #102 "recovery on timer expiry"
Cause #14 "SwMI requested disconnection"	Cause #16 "normal call clearing"
Cause #15 "Acknowledged service not completed"	Cause #31 "normal, unspecified"
Cause #16 "CAD disconnection"	Cause #31 "normal, unspecified"
Cause #32 "Call not established to critical user" (note 1)	Cause #31 "normal, unspecified"
Cause #33 "Call could not be restored to call owner" (note 1)	Cause #31 "normal, unspecified"
Cause #37 "ANF clearing to avoid a trombone or a loop connection" (note 2)	Cause #31 "normal, unspecified"
Cause #43 "Call rejected by the terminating/called SwMI because the security level at calling user air interface cannot be matched" (note 2)	Cause #127 "interworking, unspecified"
Cause #46 "Call re-routed" (note 2)	Cause #31 "normal, unspecified"
Cause #59 "Call rejected by the terminating/called SwMI: cause unspecified" (note 2)	Cause #31 "normal, unspecified"
Cause #62 "Call to be re-routed" (note 2)	Cause #31 "normal, unspecified"
NOTE 1: This is an ANF-ISIGC disconnection cause.	
NOTE 2: This is an ANF-ISIIC disconnection cause.	

Mapping of TETRA supplementary service disconnect causes should be specified in the individual TETRA supplementary service standards.

Table D.2: ISDN disconnect cause to TETRA disconnect cause

ISDN disconnect cause	TETRA disconnect cause
Cause #1 "unallocated (unassigned) number"	Cause #0 "Cause not defined or unknown "
Cause #2 "no route to specified transit network"	Cause #0 "Cause not defined or unknown "
Cause #3 " no route to destination "	Cause #0 "Cause not defined or unknown "
Cause #6 "channel unacceptable"	Cause #0 "Cause not defined or unknown "
Cause #7 "call awarded and being delivered in an established channel"	Cause #0 "Cause not defined or unknown "
Cause #16 "normal call clearing"	Cause #1 "User requested disconnect"
Cause #17 "user busy"	Cause #2 "Called party busy"
Cause #18 "no user responding"	Cause #3 "Called party not reachable"
Cause #19 "no answer from user (user alerted)"	Cause #0 "Cause not defined or unknown "
Cause #21 "call rejected"	Cause #11 "Call rejected by the called party"
Cause #22 "number changed"	Cause #0 "Cause not defined or unknown "
Cause #26 "non-selected user clearing"	Cause #0 "Cause not defined or unknown "
Cause #27 "destination out of order"	Cause #0 "Cause not defined or unknown "
Cause #28 "invalid number format"	Cause #0 "Cause not defined or unknown "
Cause #29 "facility rejected"	Cause #0 "Cause not defined or unknown "
Cause #30 "response to STATUS ENQUIRY"	Cause #0 "Cause not defined or unknown "
Cause #31 "normal, unspecified"	Cause #0 "Cause not defined or unknown "
Cause #34 "no circuit / channel available"	Cause #5 "Congestion in infrastructure"
Cause #38 "network out of order"	Cause #0 "Cause not defined or unknown "
Cause #41 "temporary failure"	Cause #0 "Cause not defined or unknown "
Cause #42 "switching equipment congestion"	Cause #5 "Congestion in infrastructure"
Cause #43 "access information discard"	Cause #0 "Cause not defined or unknown "
Cause #44 "requested circuit / channel not available"	Cause #5 "Congestion in infrastructure"
Cause #47 "resource unavailable, unspecified"	Cause #5 "Congestion in infrastructure"
Cause #49 "quality of service unavailable"	Cause #0 "Cause not defined or unknown "
Cause #50 "requested facility not subscribed "	Cause #8 "Requested service not available"
Cause #57 "bearer capability not authorized "	Cause #6 "Not allowed traffic case"
Cause #58 " bearer capability not presently available"	Cause #6 "Not allowed traffic case"
Cause #63 "service or option not available "unspecified"	Cause #8 "Requested service not available"
Cause #65 "bearer capability not implemented "	Cause #6 "Not allowed traffic case"
Cause #66 "channel type not implemented "	Cause #6 "Not allowed traffic case"
Cause #69 "requested facility not implemented"	Cause #8 "Requested service not available"
Cause #70 "only restricted digital information bearer capability is available "	Cause #0 "Cause not defined or unknown "
Cause #79 "service or option not implemented, unspecified"	Cause #8 "Requested service not available"
Cause #81 "invalid call reference value"	Cause #10 "Invalid call identifier"
Cause #82 "identified channel does not exist "	Cause #7 "Incompatible traffic case"
Cause #83 "a suspended call exists, but this call identity does not"	Cause #10 "Invalid call identifier"
Cause #84 "call identity in use"	Cause #10 "Invalid call identifier"
Cause #85 "no call suspended"	Cause #0 "Cause not defined or unknown "
Cause #86 "call having the requested call identity has been cleared"	Cause #0 "Cause not defined or unknown "
Cause #88 "incompatible destination"	Cause #0 "Cause not defined or unknown "
Cause #91 "invalid transit network selection"	Cause #0 "Cause not defined or unknown "
Cause #95 "invalid message, unspecified"	Cause #0 "Cause not defined or unknown "
Cause #96 "mandatory information element is missing"	Cause #0 "Cause not defined or unknown "
Cause #97 "message type non-existent or not implemented"	Cause #0 "Cause not defined or unknown "
Cause #98 "message not compatible with call state or message type non-existent or not implemented"	Cause #0 "Cause not defined or unknown "

ISDN disconnect cause	TETRA disconnect cause
Cause #99 "information element non-existent or not implemented"	Cause #0 "Cause not defined or unknown "
Cause #100 "invalid information element contents"	Cause #0 "Cause not defined or unknown "
Cause #101 "message not compatible with call state"	Cause #0 "Cause not defined or unknown "
Cause #102 "recovery on timer expiry"	Cause #13 "Expiry of timer"
Cause #111 "protocol error, unspecified"	Cause #0 "Cause not defined or unknown "
Cause #127 "interworking, unspecified"	Cause #0 "Cause not defined or unknown "

For any other ISDN disconnection causes, the TETRA disconnect cause #0 " Cause not defined or unknown " should be used.

Annex E (informative): TETRA supplementary services

E.1 TETRA supplementary services - SCCF

In order to control and gain access to the TETRA supplementary services it is envisaged that the ISDN subscriber employs the Service Code Command Format (SCCF) as described in ETS 300 738 [23].

Supplementary services are invoked by entering star-hash combinations and digits as defined in table 1 and in annex A of ETS 300 738 [23].

The Service Code Command (SCC) used by the ISDN subscriber to gain access to, and control of, TETRA supplementary services should have the following syntax:

"PX SC (SR SI) SX FINISH".

Where:

- PX is a mandatory service prefix;
- SC is a mandatory service code;
- SR is one or more separator/s, as required;
- SI is one or more unit of supplementary information, as required;
- SX is a service suffix, as required;
- FINISH is a finish command, when applicable.

NOTE 1: The SX service suffix is normally required as the FINISH command applicable only in the form of "on-hook", when the ISDN subscriber disconnects the ISDN call while completing a TETRA supplementary service request.

Where units of supplementary information are required, each unit of supplementary information should be preceded by a separator. The number of supplementary information units that can be included within a single command sequence is at the discretion of the terminal, network, or service provider.

NOTE 2: Services which require more than two supplementary information units may be better supported by the interactive dialogue format, see ETS 300 738 [23], subclause 6.2.

The switching order invocation of TETRA supplementary services as defined in ETS 300 738 [23], subclause 6.1.2.1 is not applicable as it would interact with the ISDN supplementary services.

The abbreviated dialing command for access to an abbreviated dialing service to dial TETRA identities where a TETRA user identity is stored within the ISDN gateway should have the following syntax:

"AN SX"

Where:

- AN is a mandatory abbreviated number; and
- SX is a mandatory service suffix.

Refer to ETS 300 738 [23], subclause 6.1.3 for further details.

Annex F (informative): Bibliography

ETSI EN 300 064-1: "Integrated Services Digital Network (ISDN); Direct Dialling In (DDI) supplementary service; Digital Subscriber Signalling System No. one (DSS1) protocol; Part 1: Protocol specification".

ETSI EN 300 061-1: "Integrated Services Digital Network (ISDN); Subaddressing (SUB) supplementary service; Digital Subscriber Signalling System No. one (DSS1) protocol; Part 1: Protocol specification".

ETSI EN 300 195-1: "Integrated Services Digital Network (ISDN); Supplementary service interactions; Digital Subscriber Signalling System No. one (DSS1) protocol; Part 1: Protocol specification".

History

Document history	
July 1999	Public Enquiry PE 9952: 1999-07-28 to 1999-11-26
May 2000	Vote V 20000707: 2000-05-08 to 2000-07-07
August 2000	First Edition