

EUROPEAN
TELECOMMUNICATION
STANDARD

FINAL DRAFT
pr **ETS 300 392-4-1**

October 1998

Source: TETRA

Reference: DE/TETRA-03001-04-1

ICS: 33.020

Key words: TETRA, V+D, PSTN

**Terrestrial Trunked Radio (TETRA);
Voice plus Data (V+D);
Part 4: Gateways basic operation;
Sub-part 1: Public Switched Telephone Network (PSTN)**

ETSI

European Telecommunications Standards Institute

ETSI Secretariat

Postal address: F-06921 Sophia Antipolis CEDEX - FRANCE

Office address: 650 Route des Lucioles - Sophia Antipolis - Valbonne - FRANCE

Internet: secretariat@etsi.fr - <http://www.etsi.org>

Tel.: +33 4 92 94 42 00 - Fax: +33 4 93 65 47 16

Copyright Notification: No part may be reproduced except as authorized by written permission. The copyright and the foregoing restriction extend to reproduction in all media.

© European Telecommunications Standards Institute 1998. All rights reserved.

Contents

Foreword	7
1 Scope	9
2 Normative references	9
3 Definitions and abbreviations	10
3.1 Definitions	10
3.2 Abbreviations	10
4 PSTN gateway stage 1 specification	11
4.1 Description	11
4.1.1 General description	11
4.1.2 Qualifications on applicability to telecommunication services	11
4.2 Procedures	11
4.2.1 Provision/withdrawal	11
4.2.2 Normal procedures	11
4.2.2.1 Activation/deactivation/registration/interrogation	11
4.2.2.2 Invocation and operation	11
4.2.3 Exceptional procedures	12
4.2.3.1 Activation/deactivation/registration/interrogation	12
4.2.3.2 Invocation and operation	12
4.3 Interaction with TETRA supplementary services	12
4.3.1 Ambience Listening (SS-AL)	12
4.3.2 Access Priority (SS-AP)	12
4.3.3 Area Selection (SS-AS)	12
4.3.4 Barring of Incoming Calls (SS-BIC)	12
4.3.5 Barring of Outgoing Calls (SS-BOC)	12
4.3.6 Call Authorised by Dispatcher (SS-CAD)	12
4.3.7 Completion of Calls to Busy Subscriber (SS-CCBS)	12
4.3.8 Completion of Calls on No Reply (SS-CCNR)	13
4.3.9 Call Forwarding Busy (SS-CFB)	13
4.3.10 Call Forwarding No Reply (SS-CFNRy)	13
4.3.11 Call Forwarding Not Reachable (SS-CFNRC)	13
4.3.12 Call Forwarding Unconditional (SS-CFU)	13
4.3.13 Calling Line Identification Presentation (SS-CLIP)	13
4.3.14 Calling/Connected Line Identification Restriction (SS-CLIR)	13
4.3.15 Connected Line Identification Presentation (SS-COLP)	13
4.3.16 Call Report (SS-CR)	13
4.3.17 Call Retention (SS-CRT)	13
4.3.18 Call Waiting (SS-CW)	13
4.3.19 Dynamic Group Number Assignment (SS-DGNA)	13
4.3.20 Discreet Listening (SS-DL)	13
4.3.21 Call Hold (SS-HOLD)	14
4.3.22 Include Call (SS-IC)	14
4.3.23 Late Entry (SS-LE)	14
4.3.24 List Search Call (SS-LSC)	14
4.3.25 Priority Call (SS-PC)	14
4.3.26 Pre-emptive Priority Call (SS-PC)	14
4.3.27 Short Number Addressing (SS-SNA)	14
4.3.28 Transfer of Control (SS-TC)	14
4.3.29 Talking Party Identification (SS-TPI)	14
4.4 Interaction with PSTN supplementary services	14
4.5 Intersystem interworking	14
4.6 PSTN gateway service description	15
4.6.1 General	15
4.6.2 PSTN gateway services offered over the PSTNCC-SAP	15

	4.6.2.1	ALERT.....	15
	4.6.2.2	CALL PROCEEDING.....	16
	4.6.2.3	CONNECT.....	16
	4.6.2.4	CONNECT-ACKNOWLEDGE.....	17
	4.6.2.5	INFORM.....	17
	4.6.2.6	RELEASE.....	17
	4.6.2.7	SETUP.....	18
	4.6.2.8	TX-CEASED.....	18
	4.6.2.9	TX-DEMAND.....	19
	4.6.2.10	TX-GRANTED.....	19
	4.6.2.11	TX-INTERRUPT.....	19
	4.6.2.12	PSTNCC-SAP parameter description.....	19
4.6.3		PSTN gateway services offered at the PSTN line interface.....	21
	4.6.3.1	PSTN line interface primitives.....	21
	4.6.3.2	PSTN CONNECT.....	21
	4.6.3.2A	PSTN DIALLING.....	21
	4.6.3.3	PSTN DIALLING TONE.....	21
	4.6.3.3A	PSTN DISCONNECT.....	21
	4.6.3.4	TETRA ALERT.....	22
	4.6.3.5	TETRA DIALLING.....	22
	4.6.3.6	TETRA DIALLING TONE.....	22
	4.6.3.7	TETRA DISCONNECT TONE.....	22
	4.6.3.8	TETRA INVALID NUMBER TONE.....	22
	4.6.3.9	TETRA TX-CEASED.....	22
	4.6.3.10	TETRA TX-CEASED TONE.....	22
	4.6.3.11	TETRA TX-DEMAND.....	23
	4.6.3.12	TETRA TX-GRANTED TONE.....	23
	4.6.3.13	TETRA TX-INTERRUPT TONE.....	23
	4.6.3.14	PSTN line interface parameter description.....	23
4.6.4		Overall SDL.....	24
5		PSTN gateway stage 2 specification.....	29
	5.1	Functional model.....	29
		5.1.1 Functional model description.....	29
		5.1.2 Description of functional entities.....	29
		5.1.2.1 PSTN gateway control entity, FE1.....	29
		5.1.2.2 PSTN call control entity, FE2.....	29
		5.1.3 Relationship of functional model to basic call functional model.....	29
	5.2	Information flow.....	30
		5.2.1 Definition of information flows.....	30
		5.2.1.1 Alert tone.....	30
		5.2.1.2 Busy tone.....	30
		5.2.1.3 Dialling.....	30
		5.2.1.4 Dialling tone.....	30
		5.2.1.5 Off-hook and on-hook.....	30
		5.2.1.6 PSTN ALERT.....	30
		5.2.1.7 PSTN disconnect tone.....	31
		5.2.1.8 Subscriber answer.....	31
		5.2.1.9 TETRA alert tone.....	31
		5.2.1.10 TETRA dialling tone.....	31
		5.2.1.11 TETRA disconnect tone.....	31
		5.2.1.12 TETRA invalid number tone.....	31
		5.2.1.13 TETRA queuing tone.....	31
		5.2.1.14 TETRA TX-DEMAND.....	31
		5.2.1.15 TX-ceased tone.....	32
		5.2.1.16 TX-granted tone.....	32
		5.2.1.17 TX-interrupt tone.....	32
		5.2.1.18 Unknown destination tone.....	32
	5.2.2	Information flow diagrams.....	32
		5.2.2.1 Successful call set-up to a PSTN subscriber using hook signalling.....	33
		5.2.2.2 Successful call set-up to a PSTN subscriber using direct call setup.....	33

5.2.2.3	Successful call set-up from a PSTN subscriber over PSTN gateway.....	34
5.2.2.4	Unsuccessful call set-up from TETRA user over PSTN gateway.....	34
5.2.2.5	Unsuccessful call set-up from a PSTN subscriber over PSTN gateway.....	35
5.2.2.6	Call maintenance procedures - Request to transmit from the PSTN subscriber	36
5.2.2.7	Call maintenance procedures - Request to transmit from a TETRA user.....	36
5.2.2.8	Call maintenance procedures - Request to interrupt.....	36
5.2.2.9	Call maintenance procedures - Request to disconnect from the TETRA user	37
5.2.2.10	Call maintenance procedures - Request to disconnect from the PSTN subscriber	37
5.2.2.11	Call maintenance procedures - Request to disconnect from the PSTN gateway.....	37
5.3	Functional entity actions	37
5.3.1	Functional entity actions of FE1	38
5.3.2	Functional entity actions of FE2	38
5.4	Allocation of functional entities to physical equipment.....	39
5.5	Inter-working considerations	39
6	PSTN gateway stage 3 specification.....	39
6.1	Protocol structure and protocol stack	39
6.2	Protocol Data Unit (PDU) descriptions	40
6.2.1	Alert tone	40
6.2.2	Busy tone.....	40
6.2.3	Dialling.....	40
6.2.4	Dialling tone.....	40
6.2.5	Off-hook	40
6.2.6	On-hook.....	41
6.2.7	PSTN ALERT	41
6.2.8	PSTN disconnect tone.....	41
6.2.9	Subscriber answer.....	41
6.2.10	TETRA alert tone.....	41
6.2.11	TETRA busy tone	41
6.2.12	TETRA dialling tone	41
6.2.13	TETRA disconnect tone	41
6.2.14	TETRA invalid number tone	41
6.2.15	TETRA queuing tone.....	41
6.2.16	TX-DEMAND	41
6.2.17	TX-ceased tone.....	41
6.2.18	TX-granted tone	42
6.2.19	TX-interrupt tone	42
6.3	PSTN GATEWAY Functional Entity FE1 behaviour	42
6.3.1	PSTN gateway FE1 protocol states	42
6.3.2	Protocol timers for FE1	42
6.3.3	Procedures of FE1	43
6.3.4	Behaviour of FE1.....	43
6.4	PSTN and PSTN subscriber Functional Entity FE2 behaviour	47
6.4.1	State IDLE	47
6.4.2	State ACTIVE	47
Annex A (informative):	Dialling for TETRA basic call.....	48
Annex B (informative):	TETRA supplementary services.....	49
Annex C (informative):	Call modifiers.....	50
Annex D (informative):	Guidance tones	51
D.1	TETRA alert tone.....	51

D.2	TETRA busy tone	51
D.3	TETRA called party not available	51
D.4	TETRA congestion tone	51
D.5	TETRA dialling tone.....	51
D.6	TETRA disconnect tone.....	51
D.7	TETRA invalid number tone	51
D.8	TETRA queuing tone	51
D.9	TX-ceased tone	51
D.10	TX-granted tone.....	52
D.11	TX-interrupt tone.....	52
History	53

Foreword

This final draft European Telecommunication Standard (ETS) has been produced by the Terrestrial Trunked Radio (TETRA) Project of the European Telecommunications Standards Institute (ETSI), and is now submitted for the Voting phase of the ETSI standards approval procedure.

This ETS is a multi-part standard and will consist of the following parts:

- Part 1: "General network design".
- Part 2: "Air Interface (AI)".
- Part 3: "Inter-System Inter-face (ISI)".
- Part 4: "Gateways".**
- Part 5: "Peripheral Equipment Interface (PEI)".
- Part 6: "Line connected Station (LS)".
- Part 7: "Security".
- Part 9: "General requirements for Supplementary Services (SS)".
- Part 10: "Supplementary Services (SS) stage 1".
- Part 11: "Supplementary Services (SS) stage 2".
- Part 12: "Supplementary Services (SS) stage 3".
- Part 13: "SDL model of the Air Interface (AI)".
- Part 14: "Protocol Implementation Conformance Statement (PICS) proforma specification".

Proposed transposition dates	
Date of latest announcement of this ETS (doa):	3 months after ETSI publication
Date of latest publication of new National Standard or endorsement of this ETS (dop/e):	6 months after doa
Date of withdrawal of any conflicting National Standard (dow):	6 months after doa

Blank page

1 Scope

This European Telecommunication Standard (ETS) defines the Terrestrial Trunked Radio (TETRA) system supporting Voice plus Data (V+D). It specifies the stage one to three of the TETRA gateway to Public Switched Telephone Network (PSTN). Stage one is an overall service description from the user's point of view, but does not deal with the details of the human interface itself.

The PSTN gateway establishes a basic call, when SwMI detects an outgoing call from a TETRA user to PSTN or the PSTN gateway detects an incoming call from PSTN to a TETRA user. The PSTN gateway ensures that basic signalling required in the operation of the TETRA call and the PSTN call is maintained across the gateway.

Circuit mode data modem types and data modem data connection set-up negotiations required to set-up circuit mode data modems used in the analogue path between the PSTN gateway and a PSTN subscriber are outside the scope of this ETS.

Support of TETRA and PSTN supplementary services is outside the scope of this ETS.

The PSTN gateway and the TETRA system is seen by the external network as it were a subscriber of the external network. For incoming calls from PSTN two step dialling is used. The dialling requires Dual Tone Multi Frequency (DTMF) capability from the PSTN user provided either by normal telephone set or by a DTMF device external to the telephone set. Other means of incoming call dialling and a direct communication, using other than PSTN subscriber lines, between TETRA system and the external network exchange are outside the scope of this ETS.

End to end encryption is outside the scope of this ETS.

Gateway specifications are presented in three stages. The stage 1 specification specifies the PSTN gateway service as seen by the TETRA system and by the PSTN subscriber. The stage 2 specification identifies the functional entities involved in the gateway service and the information flows between them. The stage 3 describes the service protocol related to the services. The described network layer services and protocols apply for the Switching and Management Infrastructure (SwMI) and for the PSTN gateway and to the keypad protocol for the PSTN subscriber using TETRA services.

This ETS describes the PSTN gateway as an Additional Network Function, which provides a PSTN interface to the SwMI. The service description is informative and does not imply any implementation.

2 Normative references

This ETS incorporates by dated and undated reference, provisions from other publications. These normative references are cited at the appropriate places in the text and the publications are listed hereafter. For dated references, subsequent amendments to or revisions of any of these publications apply to this ETS only when incorporated in it by amendment or revision. For undated references the latest edition of the publication referred to applies.

- [1] ETS 300 392-2: "Radio Equipment and Systems (RES); Trans-European Trunked Radio (TETRA); Voice plus Data (V+D); Part 2: Air Interface (AI)".
- [2] ETS 300 001: "Attachments to the Public Switched Telephone Network (PSTN); General technical requirements for equipment connected to an analogue subscriber interface in the PSTN".
- [3] ITU-T Recommendation Z.100: "Specification and Description Language".
- [4] ITU-T Recommendation I.530: "Integrated Services Digital Network (ISDN); Internetwork interfaces; Network interworking between an ISDN and a Public Switched Telephone Network (PSTN)".
- [5] ITU-T Recommendation E.180: "Telephone network and ISDN operation, numbering, routing and mobile service, Technical characteristics of tones for the telephone service".

- [6] ETS 300 738: "Human Factors (HF); Minimum Man-Machine Interface (MMI) to public network based supplementary services".
- [7] prETS 300 392-12-10: "Radio Equipment and Systems (RES); Trans-European Trunked Radio (TETRA); Voice plus Data (V+D); Part 12: Supplementary Services (SS) Stage 3; Part 12-10: Priority call (PC)".
- [8] ETS 300 392-1: "Radio Equipment and Systems (RES); Trans-European Trunked Radio (TETRA); Voice plus Data (V+D); Part 1: General network design".
- [9] prETS 300 392-12-16: "Radio Equipment and Systems (RES); Trans-European Trunked Radio (TETRA); Voice plus Data (V+D); Part 12: Supplementary Services (SS) Stage 3; Part 12-16: Pre-emptive Priority Call (PPC)".

3 Definitions and abbreviations

3.1 Definitions

For the purposes of this ETS, the following definitions apply in addition to definitions in ETS 300 392-2 [1]:

in-band tone: An audio tone indication to the user about state of the call progress. May be also an announcement.

incoming call: A call from the PSTN to the TETRA network.

outgoing call: A call from a TETRA network to the PSTN.

PSTN: Any telecommunication network, which supports analogue PSTN subscriber signalling.

PSTN subscriber: An analogue PSTN user outside TETRA addressing domain and participates in a PSTN gateway call.

TETRA user: A user within TETRA addressing domain and participates in a PSTN gateway call.

3.2 Abbreviations

For the purposes of this ETS, the following abbreviations apply:

CC	Call Control (functional entity)
CCA	Call Control Agent (functional entity)
CMCE	Circuit Mode Control Entity
DTMF	Dual Tone Multi Frequency
FE	Functional Entity
ISI	Inter System Interface
PABX	Private Automatic Branch Exchange (analogue network)
PDU	Protocol Data Unit
PSTN	Public Switched Telephone Network (analogue network)
PSTNCC-SAP	Public Switched Telephone Network gateway Call Control Service Access Point
PSTND-SAP	Public Switched Telephone Network gateway D Service Access Point
SCC	Service Code Command
SCCF	Service Code Command Format
SDL	Specification and Description Language
SSI	Short Subscriber Identity
SwMI	Switching and Management Infrastructure
TETRA	Terrestrial Trunked Radio

4 PSTN gateway stage 1 specification

4.1 Description

4.1.1 General description

The PSTN gateway enables calls to be set-up from a TETRA user to a PSTN subscriber and from a PSTN subscriber to a TETRA user. Additionally, for the duration of the call, the PSTN gateway allows TETRA signalling information to be passed from TETRA Switching and Management Infrastructure (SwMI) to the external network user and from the external network user to the TETRA SwMI in accordance with the TETRA Call Control (CC) procedures as defined in ETS 300 392-2 [1].

The principles defined in this ETS can be used for interfacing with other networks such as analogue private networks (e.g. Private Automatic Branch Exchange (PABX)).

4.1.2 Qualifications on applicability to telecommunication services

The PSTN gateway shall be applicable to clear mode point-to-point and point-to-multipoint circuit mode basic services as defined in ETS 300 392-2 [1]. End-to-end encryption could be supported between a TETRA user and the PSTN gateway, but all provisions are outside the scope of this ETS.

Circuit mode data modem types and data modem data connection set-up negotiations required to configure circuit mode data modems used in the analogue path between the PSTN gateway and a PSTN subscriber are outside the scope of this ETS.

4.2 Procedures

4.2.1 Provision/withdrawal

The PSTN gateway service shall be provided by prior arrangement with the service provider or they may be generally available.

This service may be withdrawn by the service provider at any time without a prior indication.

4.2.2 Normal procedures

4.2.2.1 Activation/deactivation/registration/interrogation

PSTN gateway shall be permanently activated upon provision.

Registration and interrogation are not applicable.

4.2.2.2 Invocation and operation

The PSTN gateway shall be invoked either when a call request has been received (outgoing call) by the SwMI to a PSTN subscriber, or when a call request (incoming call) is received by the gateway from the PSTN.

In the outgoing call case the PSTN gateway shall route the call to the PSTN network using the information found in the TETRA address and/or in the external subscriber address element. The PSTN gateway shall dial the external network number using appropriate dialling mechanisms defined for that network (see ETS 300 001 [2] or relevant national requirement not covered by ETS 300 001 [2]).

In the incoming call case the PSTN gateway shall forward the called TETRA user identity to the SwMI CC entity for the call set-up completion.

The PSTN gateway shall remain operational for the duration of the call, sending and receiving TETRA signalling messages as appropriate under direction from the SwMI.

A PSTN gateway supporting full duplex calls shall ensure an appropriate echo cancellation for PSTN (see ITU-T Recommendation I.530 [4]).

A PSTN gateway supporting semi-duplex calls may inform the PSTN subscriber about the state of the call and may either receive explicit requests to transmit from the external network user, or use a voice detection mechanism for the requests to transmit. The exact mechanisms for voice detection, and its algorithms, and how the result is used for the request to transmit are outside the scope of this ETS.

4.2.3 Exceptional procedures

4.2.3.1 Activation/deactivation/registration/interrogation

Are not applicable.

4.2.3.2 Invocation and operation

The PSTN gateway may reject the call request with an appropriate failure indication for any of the following reasons:

- no destination number provided;
- PSTN access line congestion;
- the called user does not answer;
- the called user is busy;
- the called user address is incorrect.

In addition, all restrictions and exceptional procedures for TETRA basic call establishment shall apply.

4.3 Interaction with TETRA supplementary services

Interactions with invocation and operation of supplementary services are specified below.

4.3.1 Ambience Listening (SS-AL)

There shall be no interaction. A PSTN subscriber cannot be ambience listened to.

4.3.2 Access Priority (SS-AP)

Shall not be applicable.

4.3.3 Area Selection (SS-AS)

There shall be no interaction. The SS-AS information exchange with the PSTN subscriber may be limited.

4.3.4 Barring of Incoming Calls (SS-BIC)

There shall be no interaction. The SS-BIC information exchange with the PSTN subscriber may be limited.

4.3.5 Barring of Outgoing Calls (SS-BOC)

There shall be no interaction. The SS-BOC information exchange with the PSTN subscriber may be limited.

4.3.6 Call Authorised by Dispatcher (SS-CAD)

There shall be no interaction. The SS-CAD information exchange with the PSTN subscriber may be limited.

4.3.7 Completion of Calls to Busy Subscriber (SS-CCBS)

There shall be no interaction. The SS-CCBS information exchange with the PSTN subscriber may be limited.

4.3.8 Completion of Calls on No Reply (SS-CCNR)

There shall be no interaction. The SS-CCNR information exchange with the PSTN subscriber may be limited.

4.3.9 Call Forwarding Busy (SS-CFB)

There shall be no interaction. The SS-CFB information exchange with the PSTN subscriber may be limited.

4.3.10 Call Forwarding No Reply (SS-CFNRy)

There shall be no interaction. The SS-CFNRy information exchange with the PSTN subscriber may be limited.

4.3.11 Call Forwarding Not Reachable (SS-CFNRc)

There shall be no interaction. SS-CFNRc cannot be activated against PSTN user or users as the PSTN users shall be considered always reachable. The SS-CFNRc information exchange with the PSTN subscriber may be limited.

4.3.12 Call Forwarding Unconditional (SS-CFU)

There shall be no interaction. The SS-CFU information exchange with the PSTN subscriber may be limited.

4.3.13 Calling Line Identification Presentation (SS-CLIP)

There shall be no interaction. The SS-CLIP information exchange to the PSTN subscriber may be limited. The calling PSTN subscriber number may not be available.

4.3.14 Calling/Connected Line Identification Restriction (SS-CLIR)

There shall be no interaction. The PSTN line presentation shall be independent of TETRA SS-CLIR.

4.3.15 Connected Line Identification Presentation (SS-COLP)

There shall be no interaction. The SS-COLP information exchange to the external user may be limited. The connected PSTN subscriber number may not be available.

4.3.16 Call Report (SS-CR)

There shall be no interaction. The SS-CR information exchange with the PSTN subscriber may be limited.

4.3.17 Call Retention (SS-CRT)

There shall be no interaction. The SS-CRT information exchange with the PSTN subscriber may be limited.

4.3.18 Call Waiting (SS-CW)

There shall be no interaction. The SS-CW information exchange with the PSTN subscriber may be limited.

4.3.19 Dynamic Group Number Assignment (SS-DGNA)

There shall be no interaction.

4.3.20 Discreet Listening (SS-DL)

There shall be no interaction. The listening invocation service may be provided to a PSTN subscriber with special arrangements outside this ETS.

4.3.21 Call Hold (SS-HOLD)

There shall be no interaction. The SS-HOLD information exchange with the PSTN subscriber may be limited.

4.3.22 Include Call (SS-IC)

There shall be no interaction. The SS-IC information exchange with the PSTN subscriber may be limited.

4.3.23 Late Entry (SS-LE)

Shall not be applicable.

4.3.24 List Search Call (SS-LSC)

There shall be no interaction. The SS-LSC information exchange with the PSTN subscriber may be limited.

4.3.25 Priority Call (SS-PC)

There shall be no interaction. The SS-PC information exchange with the PSTN subscriber may be limited.

4.3.26 Pre-emptive Priority Call (SS-PC)

There shall be no interaction. The SS-PC information exchange with the PSTN subscriber may be limited.

4.3.27 Short Number Addressing (SS-SNA)

There shall be no interaction. The SS-SNA information exchange with the PSTN subscriber may be limited.

4.3.28 Transfer of Control (SS-TC)

There shall be no interaction. The SS-TC information exchange with the PSTN subscriber may be limited.

4.3.29 Talking Party Identification (SS-TPI)

There shall be no interaction. The SS-TPI information exchange with the PSTN subscriber may be limited.

4.4 Interaction with PSTN supplementary services

There shall be no interaction between PSTN gateway and PSTN supplementary services.

4.5 Intersystem interworking

TETRA intersystem interworking shall not interact with the PSTN gateway functions. Outgoing calls to the PSTN may be routed to another SwMI and incoming calls from the PSTN may be routed to another SwMI.

4.6 PSTN gateway service description

4.6.1 General

This subclause describes services offered by the PSTN gateway at the Circuit Mode Control Entity (CMCE) CC Service Access Point (PSTNCC-SAP) of a TETRA V+D layer 3 service boundary inside a SwMI and at the PSTN subscriber line interface point as presented in figure 1.

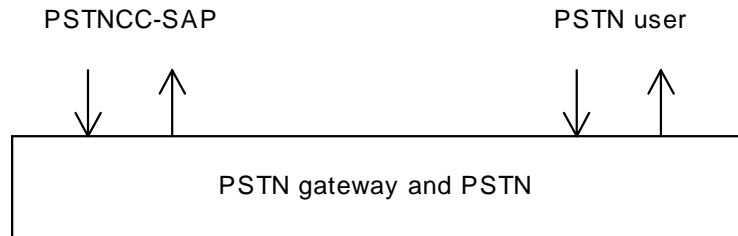

Figure 1: Service description model

The information contained in the following primitive description tables corresponds to the following key:

- C/O/M: conditional/optional/mandatory.

4.6.2 PSTN gateway services offered over the PSTNCC-SAP

The primitives for the PSTN gateway services shall support a subset of the air interface services. The external subscriber address in the air interface SETUP PDU shall be used as a PSTN address (see ETS 300 392-2 [1]). The primitives refer to one instance of a PSTN gateway call by a call identifier parameter.

NOTE: This SAP is defined for service description purposes and is not intended to present or restrict any implementation.

In addition to these service primitives the TETRA user may receive various in-band tones (guidance and supervisory tones) or announcements from the PSTN such as:

- alert tone;
- busy tone;
- PSTN disconnect tone.

See subclause 5.2.1 for more details.

4.6.2.1 ALERT

ALERT request primitive shall indicate to the PSTN gateway that the called TETRA user is being alerted.

ALERT indication primitive shall indicate that the called PSTN subscriber is being alerted. A PSTN generated tone may replace the indication primitive in direct call set-up.

Table 1 lists the parameters within the ALERT primitive.

Table 1: Parameters for the ALERT primitive

Parameter	Request	Indication
Call identifier	M	M
Call time-out, set-up phase	M	M
Hook method selection	M	M
Simplex/duplex selection	M	M
Call queued	O	O
Basic service information	O	O
Facility	O	O

4.6.2.2 CALL PROCEEDING

CALL PROCEEDING indication primitive acknowledges that the PSTN call is processed.

Table 2 lists the parameters within the CALL PROCEEDING primitive.

Table 2: Parameters for the CALL PROCEEDING primitive

Parameter	Indication
Call identifier	M
Call time-out, set-up phase	M
Hook method selection	M
Simplex/duplex selection	M
Basic service information	O
Call status	O
Notification indicator	O
Facility	O

4.6.2.3 CONNECT

CONNECT request primitive shall acknowledge that the called TETRA user is ready for through connection.

CONNECT indication primitive shall acknowledge that the called PSTN subscriber is alerted or ready for through connection.

Table 3 lists the parameter within the CONNECT primitive.

Table 3: Parameters for the CONNECT primitive

Parameter	Request	Indication
Call identifier	M	M
Call time-out	M	-
Hook method selection	M	M
Simplex/duplex selection	M	M
Transmission grant	M	-
Transmission request permission	M	-
Call priority	O	-
Basic service information	O	O
Call queued	O	-
Notification indicator	O	O
Facility	O	O

4.6.2.4 CONNECT-ACKNOWLEDGE

CONNECT-ACKNOWLEDGE request shall order the PSTN gateway to through connect to the called PSTN subscriber.

Table 4 lists the parameters within the CONNECT-ACKNOWLEDGE primitive.

Table 4: Parameters for the CONNECT-ACKNOWLEDGE primitive

Parameter	Request
Call identifier	M
Call time-out	M
Call queued	M
Transmission grant	M
Transmission request permission	M
Notification indicator	O
Facility	O

4.6.2.5 INFORM

INFORM indication and request shall be used to convey call related information between the SwMI and the PSTN or PSTN subscriber.

Table 5 lists the parameters within the INFORM primitive.

Table 5: Parameters for the INFORM primitive

Parameter	Request	Indication
Call identifier	M	M
Reset call time-out timer (T310)	M	-
Call time-out	O	-
Call time-out, set-up phase	O	-
Modify	O	O
Call status	O	-
Notification indicator	O	O
External subscriber number, DTMF	O	O
Facility	O	O

4.6.2.6 RELEASE

RELEASE request shall order the gateway to disconnect the PSTN call.

RELEASE indication shall indicate that the gateway has disconnected the PSTN call.

Table 6 lists the parameters within the RELEASE primitive.

Table 6: Parameters for the RELEASE primitive

Parameter	Request	Indication
Call identifier	M	M
Disconnect cause	M	M
Notification indicator	O	O
Facility	O	O

4.6.2.7 SETUP

SETUP request shall enable a TETRA call to be set-up through the PSTN gateway to the called PSTN subscriber.

SETUP indication shall inform an incoming call from the calling PSTN subscriber.

Table 7 lists the parameters within the SETUP primitive.

Table 7: Parameters for the SETUP primitive

Service element	Request	Indication
Call identifier	M	-
Called user's destination number	M	M
Area selection	-	M
Call time-out	M	-
Hook method selection	M	M
Simplex/duplex selection	M	M
Basic service information	M	M
Transmission grant	M	-
Transmission request permission	M	-
Request to transmit	-	M
Call priority	M	M
Notification indicator	O	O
Calling party identification	O	O
Facility	O	O

4.6.2.8 TX-CEASED

TX-CEASED request shall indicate to the PSTN gateway that transmission from the talking party has ceased.

TX-CEASED indication shall inform that the PSTN subscriber has ceased to transmit.

Table 8 lists the parameters within the TX-CEASED primitive.

Table 8: Parameters for the TX-CEASED primitive

Parameter	Request	Indication
Call identifier	M	M
Transmission request permission	M	-
Notification indicator	O	O
Facility	O	O

4.6.2.9 TX-DEMAND

TX-DEMAND indication shall indicate a demand for transmission from the PSTN subscriber.

Table 9 lists the parameters within the TX-DEMAND primitive.

Table 9: Parameters for the TX-DEMAND primitive

Parameter	Indication
Call identifier	M
TX demand priority	O
Encryption control	O
Speech service	O
Facility	O

4.6.2.10 TX-GRANTED

TX-GRANTED request shall indicate to whom the demand for permission to transmit is to be granted.

Table 10 lists the parameters within the TX-GRANTED primitive.

Table 10: Parameters for the TX-GRANTED primitive

Parameter	Request
Call identifier	M
Transmission grant	M
Transmission request permission	M
Encryption control	M
Speech service	M
Notification indicator	O
Facility	O

4.6.2.11 TX-INTERRUPT

TX-INTERRUPT request shall indicate that permission to transmit has been withdrawn.

Table 11 lists the parameters within the TX-INTERRUPT primitive.

Table 11: Parameters for the TX-INTERRUPT primitive

Parameter	Request
Call identifier	M
Transmission grant	M
Transmission request permission	M
Encryption control	M
Speech service	M
Notification indicator	O
Facility	O

4.6.2.12 PSTNCC-SAP parameter description

The parameters of the informative service primitives shall have values specified below. These values are selected to correspond to element values used in the air interface protocol PDUs.

- area selection:
 - see ETS 300 392-2 [1], subclause 11.3.4;

- basic service information (a set of parameters):
 - see ETS 300 392-2 [1], subclause 11.3.4;
- call status:
 - see ETS 300 392-2 [1], subclause 11.3.4;
- call time-out:
 - see ETS 300 392-2 [1], subclause 11.3.4 and ETS 300 392-2 [1], subclause 14.2.15 for the time-out values;
- call time-out, set-up phase:
 - see ETS 300 392-2 [1], subclause 11.3.4 and see ETS 300 392-2 [1], subclause 14.2.16 for the time-out values;
- called user's destination number:
 - TETRA identity;
 - PSTN subscriber number;
- calling party identification:
 - TETRA identity;
 - PSTN subscriber number;
- call:
 - see ETS 300 392-2 [1], subclause 11.3.4 and ETS 300 392-12-10 [7], and ETS 300 392-12-16 [9] for priority values;
- circuit mode service:
 - see ETS 300 392-2 [1], subclause 11.3.4;
- communication type:
 - see ETS 300 392-2 [1], subclause 11.3.4;
- disconnect cause:
 - see ETS 300 392-2 [1], subclause 11.3.4;
- encryption flag:
 - see ETS 300 392-2 [1], subclause 11.3.4;
- hook method selection:
 - see ETS 300 392-2 [1], subclause 11.3.4;
- PSTN subscriber number:
 - up to 24 digits composed of Dual Tone Multi-Frequency (DTMF) digits as follows:
 - 0 digit 0
 - etc. ..., etc.
 - 9 digit 9
 - 10 digit *
 - 11 digit #

- request to transmit:
 - see ETS 300 392-2 [1], clause 11.3.4;
- simplex/duplex selection:
 - see ETS 300 392-2 [1], subclause 11.3.4;
- speech service:
 - see ETS 300 392-2 [1], subclause 11.3.4;
- transmission request permission:
 - see ETS 300 392-2 [1], subclause 11.3.4;
- transmission grant:
 - see ETS 300 392-2 [1], subclause 11.3.4;
- Tx demand priority:
 - see ETS 300 392-2 [1], subclause 11.3.4.

4.6.3 PSTN gateway services offered at the PSTN line interface

4.6.3.1 PSTN line interface primitives

The informative primitives for a PSTN subscriber at the PSTN subscriber line interface shall be as defined in the following subclauses. Some primitives map directly on in-band tones or announcements. The recommended TETRA tones are defined in annex D. The announcements, which may amend or replace any or all of the in-band tones, are outside the scope of this ETS, see ITU-T Recommendation E.180 [5] for more details.

4.6.3.2 PSTN CONNECT

PSTN CONNECT request shall inform PSTN that the called PSTN subscriber has answered.

ETS 300 001 [2] or relevant national requirement not covered by ETS 300 001 [2] defines PSTN CONNECT request as off-hook.

4.6.3.2A PSTN DIALLING

PSTN DIALLING request should carry a TETRA gateway number.

ETS 300 001 [2] or relevant national requirement not covered by ETS 300 001 [2] defines PSTN DIALLING.

4.6.3.3 PSTN DIALLING TONE

PSTN DIALLING TONE indication should command the PSTN subscriber to dial a TETRA gateway number.

ETS 300 001 [2] or relevant national requirement not covered by ETS 300 001 [2] defines this tone.

4.6.3.3A PSTN DISCONNECT

PSTN DISCONNECT indication shall indicate to the PSTN subscriber that PSTN has released the PSTN call.

See ETS 300 001 [2] or relevant national requirement not covered by ETS 300 001 [2] for optional PSTN DISCONNECT indication capabilities.

PSTN DISCONNECT request shall indicate to PSTN that the PSTN subscriber has released the call or call attempt.

ETS 300 001 [2] or relevant national requirement not covered by ETS 300 001 [2] defines PSTN DISCONNECT request as on-hook.

4.6.3.4 TETRA ALERT

TETRA ALERT indication shall inform the PSTN subscriber that the called TETRA user has been alerted. The recommended tone for this indication is defined in annex D.

4.6.3.5 TETRA DIALLING

TETRA DIALLING request shall convey the called TETRA user identity. The identity shall be a sequence of DTMF digits. The called user's destination number may be also defined by the PSTN access number without two step dialling e.g. when predefined PSTN or PABX numbers are allocated to certain TETRA users or functions such as dispatchers. The allocation of those numbers is outside the scope of this ETS. Also the service parameter may be defined by the PSTN access number without parameters in the TETRA DIALLING request.

Table 12 lists the parameters within the TETRA DIALLING primitive.

Table 12: Parameters for the TETRA DIALLING primitive

Parameter	Request
Called TETRA identity	M
Area selection	O
Simplex/duplex selection	O
Basic service information	O
Request to transmit	O
Call priority	O
Calling party identification	O
Facility	O

4.6.3.6 TETRA DIALLING TONE

TETRA DIALLING TONE indication shall indicate to the PSTN subscriber that he may proceed to dial a TETRA identity.

4.6.3.7 TETRA DISCONNECT TONE

TETRA DISCONNECT TONE indication shall indicate to the PSTN subscriber that the call or call attempt to a TETRA user has been released.

4.6.3.8 TETRA INVALID NUMBER TONE

Optional TETRA INVALID NUMBER TONE indication shall indicate to the PSTN subscriber that the call attempt to a TETRA use has been rejected due to invalid number.

4.6.3.9 TETRA TX-CEASED

Optional TETRA TX-CEASED request may be used to indicate an end of transmission from the PSTN subscriber. The PSTN subscriber may also imply the end of transmission by ceasing to talk.

4.6.3.10 TETRA TX-CEASED TONE

Optional TETRA TX-CEASED TONE indication may be used to indicate an end of transmission.

4.6.3.11 TETRA TX-DEMAND

Optional TETRA TX-DEMAND request shall be used to perform a transmission request from the PSTN subscriber. The PSTN subscriber may also imply the transmission request by starting to talk.

Table 13 lists the parameters within the TETRA TX-DEMAND primitive.

Table 13: Parameters for the TETRA TX-DEMAND primitive

Parameter	Request
TX demand priority	O (note)
NOTE: This parameter may have also a value indicating a pre-emptive request.	

4.6.3.12 TETRA TX-GRANTED TONE

Optional TETRA TX-GRANTED TONE indication may be used to inform the PSTN subscriber that he or somebody else is permitted to transmit. The transmission grant can also be implicit, when the PSTN subscriber cannot detect anybody else to talk after noting a TX-CEASED TONE, see subclause 4.6.3.10.

Table 14 lists the parameters within the TETRA TX-GRANTED TONE primitive.

Table 14: Parameters for the TETRA TX-GRANTED TONE primitive

Parameter	Indication
Transmission grant	M

4.6.3.13 TETRA TX-INTERRUPT TONE

Optional TETRA TX-INTERRUPT TONE indication may be used to inform the PSTN subscriber that permission to transmit has been withdrawn.

4.6.3.14 PSTN line interface parameter description

The parameters of the service primitives shall have values specified below. These values are selected to correspond to element values used in the air interface protocol. The indications to the PSTN subscriber can be in-band tones or sequences of in-band tones, see annex D.

- area selection:
 - 0 area not defined;
 - 1 area 1;
 - etc. ..., etc.;
 - 14 area 14;
 - 15 all areas in this system.
- NOTE: The other area number definitions are outside the scope of this ETS. Some of the area definitions may have no meaning for PSTN calls such as "small area around the serving cell".
- basic service information (a set of parameters):
 - circuit mode service;
 - communication type;
 - data service;
 - data call capacity (data service only);
 - encryption flag;
 - speech service.
- called TETRA identity:

- TETRA individual or group identity encoded into DTMF digits, see ETS 300 392-2 [1], subclause 14.7.
- call priority:
 - see ETS 300 392-12-10 [7] and ETS 300 392-12-16 [9] for priority values.
- transmission grant:
 - 1 transmission granted;
 - 2 transmission granted to another user;
- Tx demand priority:
 - 1 low priority level;
 - 2 high priority level;
 - 3 pre-emptive priority level;
 - 4 emergency pre-emptive priority level.

4.6.4 Overall SDL

Figures 2, 3, 4 and 5 contain the dynamic description of PSTN gateway call set-up and call maintenance using the Specification and Description Language (SDL) defined in ITU-T Recommendation Z.100 [3]. Input signals from the right originates from the TETRA SwMI or TETRA user actions and output signals to the right are towards to the TETRA user. Input signals from the left are from the PSTN subscriber and output signals to the left are towards the PSTN user. The SDL models describe a semi-duplex call. For a full-duplex call the call maintenance is limited to the disconnection function and states PSTN RECEIVING and PSTN SENDING are merged together.

The states used in the description are:

- IDLE:
 - PSTN gateway is ready to accept call invocations;
- PSTN RECEIVING:
 - TETRA user has permission to transmit;
- PSTN SENDING:
 - PSTN user has permission to transmit;
- WAIT ANSWER:
 - PSTN gateway is waiting TETRA user answer;
- WAIT PSTN ANSWER:
 - PSTN gateway is ready to accept PSTN subscriber answer;
- WAIT PSTN DIALLING:
 - PSTN is waiting dialling from the calling PSTN subscriber; and
- WAIT TETRA DIALLING:
 - PSTN gateway is waiting dialling of a TETRA number.

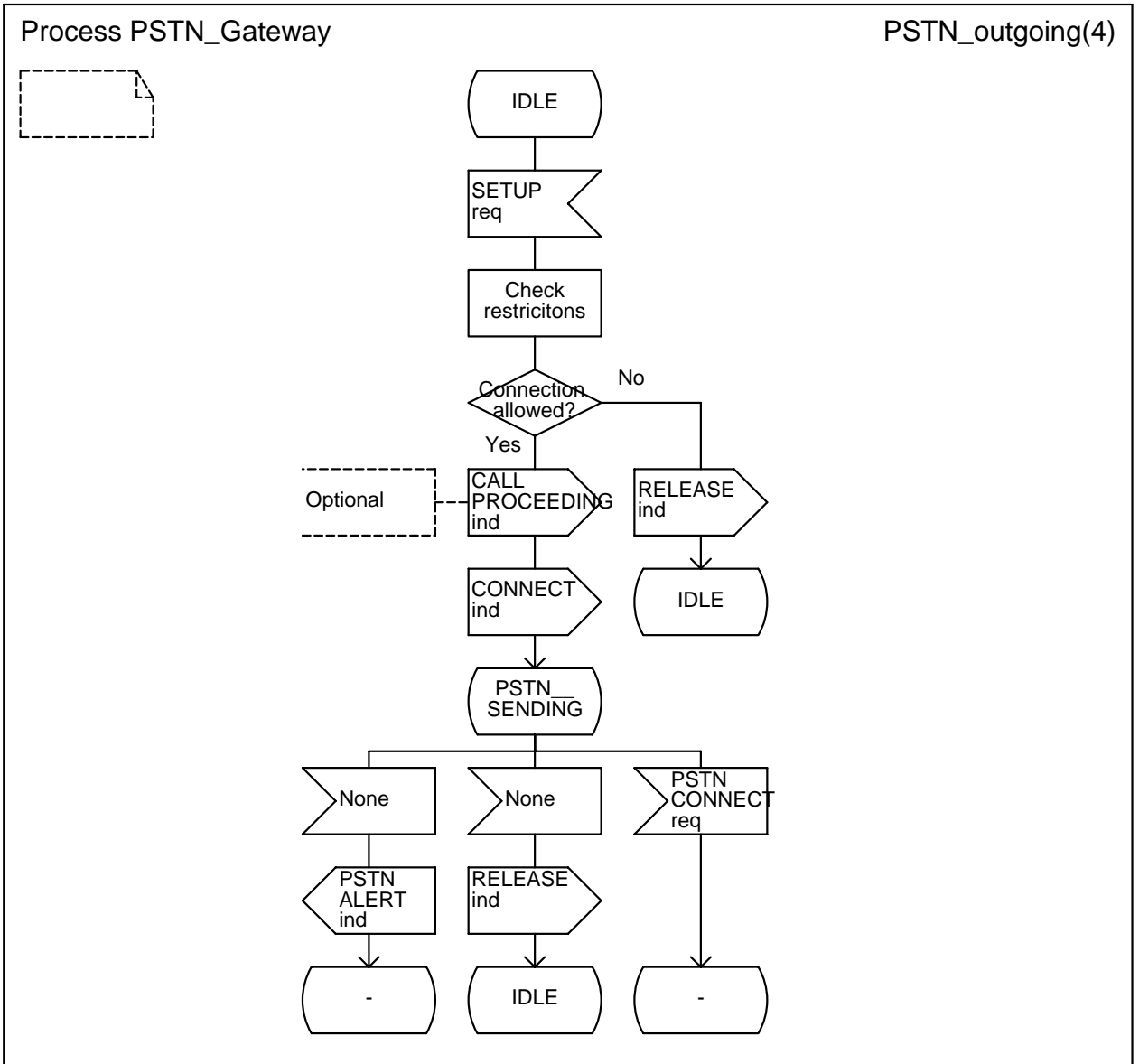

Figure 2: PSTN gateway, outgoing call, direct call set-up

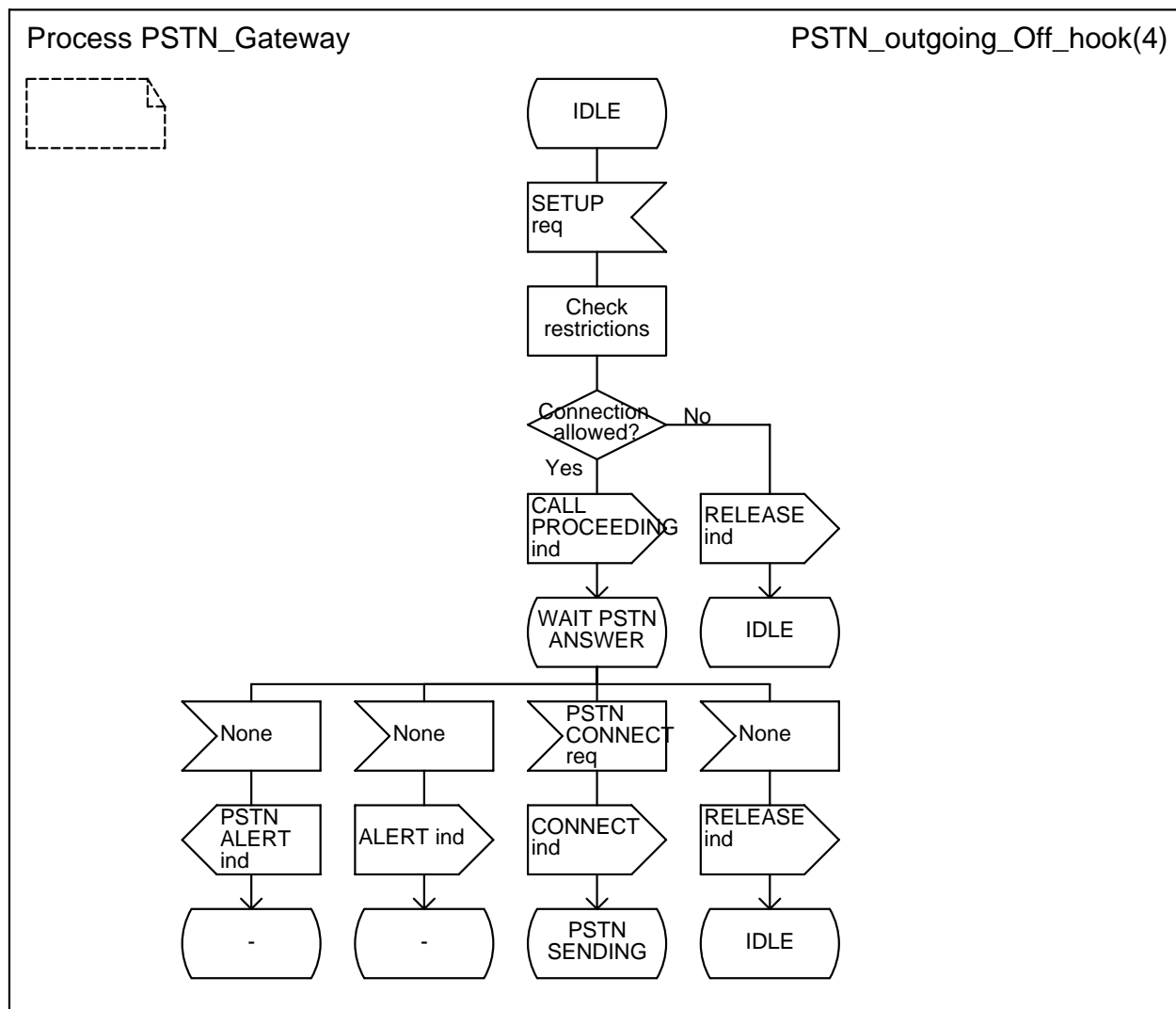

Figure 3: PSTN gateway, outgoing call, hook signalling call set-up

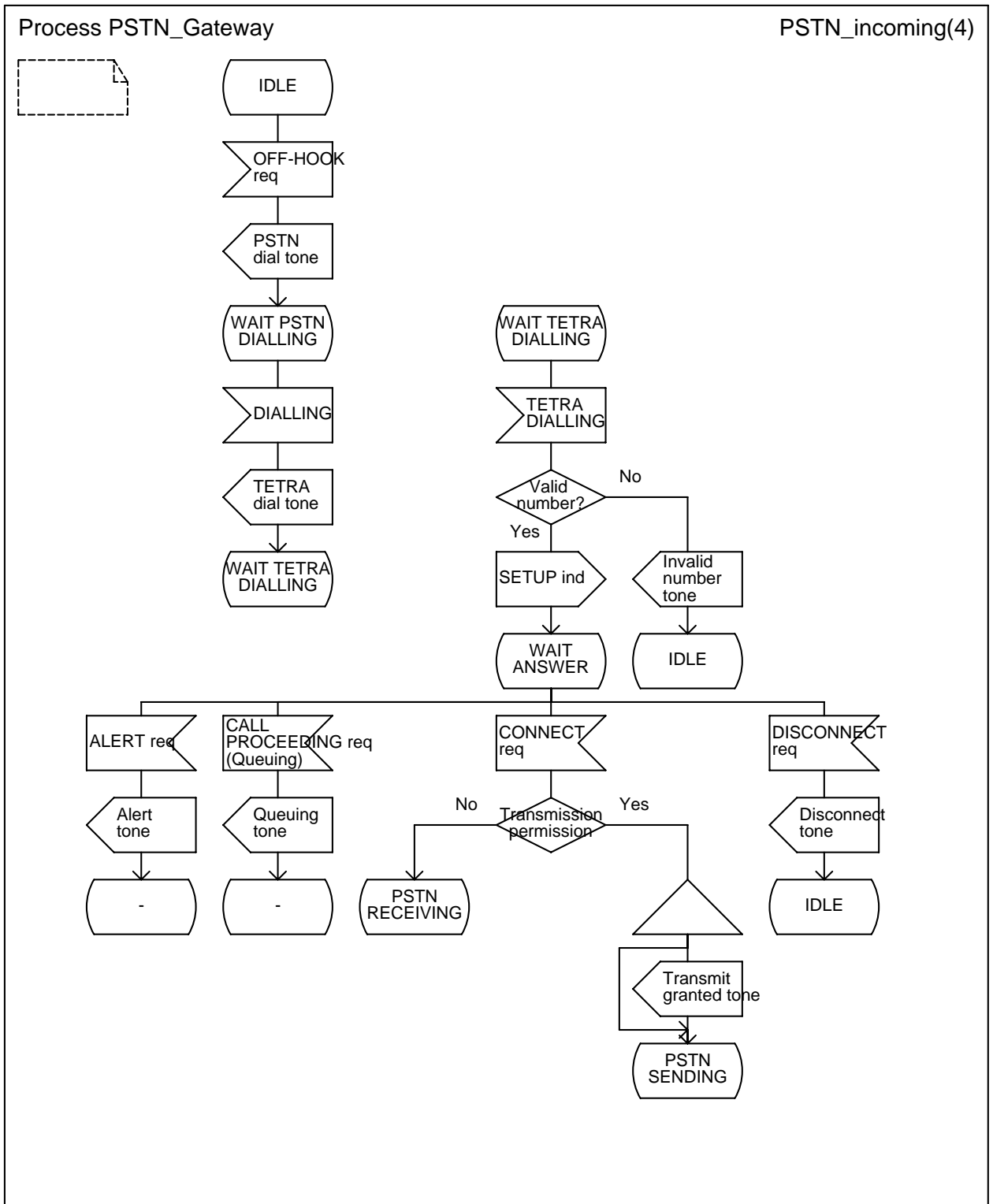

Figure 4: PSTN gateway, incoming call

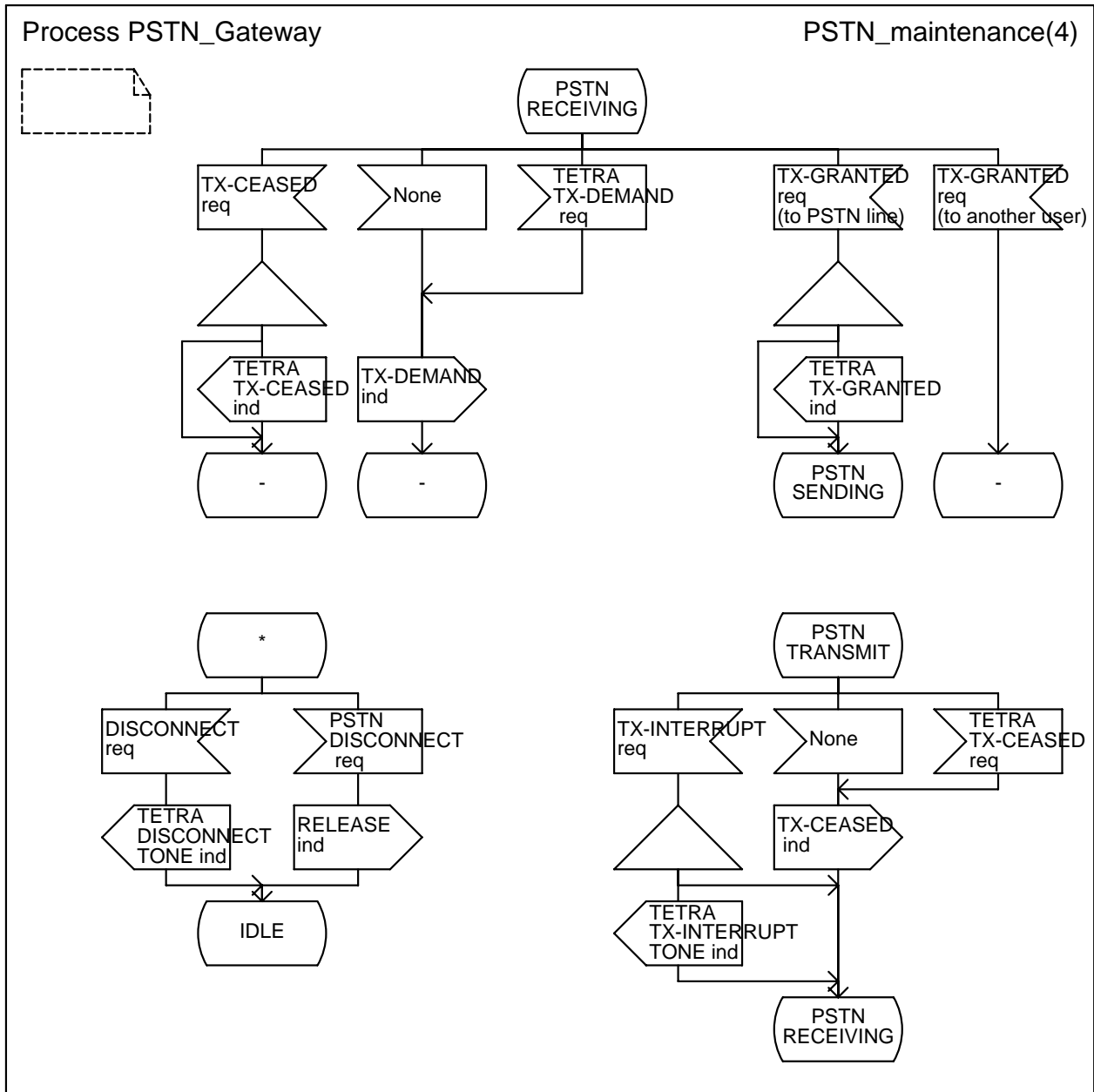

Figure 5: PSTN gateway, call maintenance

5 PSTN gateway stage 2 specification

5.1 Functional model

5.1.1 Functional model description

The functional model shall comprise the following functional entities:

FE1: PSTN gateway control entity;

FE2: Combined PSTN and PSTN subscriber entity.

The following functional relationships shall exist between these FEs:

ra: between FE1 and FE2.

Figure 6 shows these FEs and relationships.

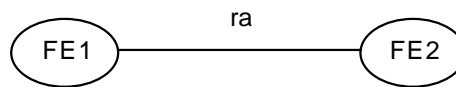

Figure 6: Functional model for PSTN gateway relationships

NOTE: The actions and functions of PSTN and PSTN subscriber are not separated in this functional model as they are mainly outside the scope of this ETS.

5.1.2 Description of functional entities

5.1.2.1 PSTN gateway control entity, FE1

This functional entity:

- detects an outgoing call;
- dials PSTN subscriber number;
- detects an incoming call from FE2;
- accepts TETRA number (identity) dialling from PSTN subscriber;
- optionally detects PSTN in-band tones;
- optionally generates in-band tones to PSTN subscriber;
- optionally detects PSTN subscriber disconnection;
- optionally detects PSTN subscriber answer.

5.1.2.2 PSTN call control entity, FE2

This functional entity:

- detects a call from FE1;
- initiates a call to FE1;
- exchanges information with FE2.

5.1.3 Relationship of functional model to basic call functional model

Figure 7 shows mapping of functional entities over the basic call model.

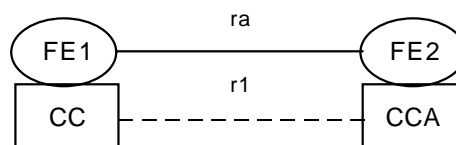

Figure 7: Relationship between models for PSTN gateway and basic call

5.2 Information flow

5.2.1 Definition of information flows

In the tables listing the elements in information flows, the column headed "Request/Indication" indicates which of these elements are mandatory (M) and which are optional (O) in a request/indication information flow. The service primitives and parameters in the service primitives are described in clause 4.

NOTE: The service primitives form a part of the information flows at the boundaries of this additional network service.

5.2.1.1 Alert tone

Alert tone is an optional unconfirmed information flow across ra from FE2 to FE1. The alert tone shall indicate that the called PSTN subscriber has been alerted.

It is optional for the PSTN gateway to recognise alert tone.

The alert tone from the PSTN is defined in ETS 300 001 [2] or relevant national requirement not covered by ETS 300 001 [2].

5.2.1.2 Busy tone

Busy tone is an optional unconfirmed information flow across ra from FE2 to FE1. Busy tone shall indicate that the called PSTN subscriber is engaged in another call.

The busy tone from the PSTN is defined in ETS 300 001 [2] or relevant national requirement not covered by ETS 300 001 [2].

5.2.1.3 Dialling

Dialling is an unconfirmed information flow across ra from FE1 to FE2 or from FE2 to FE1. It shall contain the dialling information. The dialling may contain also supplementary service information.

NOTE: This PSTN gateway presentation and dialling assumes that the PSTN is transparent to DTMF signalling and does not interact with or modify any of the dialled digits.

The recommended TETRA dialling is defined in annex A.

The dialling of TETRA supplementary services is described in annex B.

5.2.1.4 Dialling tone

Dialling tone is an unconfirmed information flow across ra from FE2 to FE1. Dialling tone shall indicate to the calling TETRA user that the PSTN is ready to receive dialling information.

The dialling tone from the PSTN is defined in ETS 300 001 [2] or relevant national requirement not covered by ETS 300 001 [2].

5.2.1.5 Off-hook and on-hook

These physical layer signals shall be used to indicate PSTN gateway activity to the PSTN. In the on-hook condition the PSTN gateway is in idle state and there is no loop current. In the off-hook condition the PSTN gateway is in active state and a loop current is flowing. See ETS 300 001 [2] or relevant national requirement not covered by ETS 300 001 [2] for further details on the PSTN line conditions.

5.2.1.6 PSTN ALERT

PSTN ALERT is an unconfirmed information flow across ra from FE2 to FE1. It shall indicate to the PSTN gateway an incoming call from a PSTN subscriber. This information flow is commonly known as ringing signal.

ETS 300 001 [2] or relevant national requirement not covered by ETS 300 001 [2] defines further details and national requirements on ringing signal.

5.2.1.7 PSTN disconnect tone

PSTN disconnect tone is an unconfirmed information flow across ra from FE2 to FE1. It shall indicate to the PSTN gateway that PSTN has disconnected the call.

ETS 300 001 [2] or relevant national requirement not covered by ETS 300 001 [2] defines further details and national requirements on PSTN disconnect tone.

5.2.1.8 Subscriber answer

Subscriber answer is an optional unconfirmed information flow across ra from FE2 to FE1. It shall indicate when the called PSTN subscriber answers.

ETS 300 001 [2] or relevant national requirement not covered by ETS 300 001 [2] defines further details and national requirements on subscriber answer signalling.

5.2.1.9 TETRA alert tone

TETRA alert tone is an optional unconfirmed information flow across ra from FE1 to FE2. TETRA alert tone shall indicate to the PSTN subscriber that the called TETRA user has been alerted.

A recommendation for a TETRA alert tone is given in annex D.

5.2.1.10 TETRA dialling tone

TETRA dialling tone is an unconfirmed information flow across ra from FE1 to FE2. TETRA dialling tone shall indicate to the PSTN subscriber that the PSTN gateway is ready to receive dialling information.

A recommendation for a TETRA dialling tone is given in annex D.

5.2.1.11 TETRA disconnect tone

TETRA disconnect tone is an optional unconfirmed information flow across ra from FE1 to FE2. It shall indicate to the PSTN subscriber that the dialled number is not a valid TETRA address in this system or the call was not allowed or accepted.

A recommendation for a TETRA disconnect tone is given in annex D.

5.2.1.12 TETRA invalid number tone

TETRA invalid number tone is an optional unconfirmed information flow across ra from FE1 to FE2. It shall indicate to the PSTN subscriber that the dialled number is not a valid TETRA address.

A recommendation for a TETRA disconnect tone is given in annex D.

5.2.1.13 TETRA queuing tone

TETRA queuing tone is an optional unconfirmed information flow across rb from FE1 to FE2. It shall indicate to the PSTN subscriber that the TETRA call is queued.

A recommendation for a TETRA queuing tone is given in annex D.

5.2.1.14 TETRA TX-DEMAND

TETRA TX-DEMAND is an optional unconfirmed information flow across ra from FE2 to FE1. It shall indicate that the PSTN subscriber has asked permission to talk.

Table 15 lists the elements of the TETRA TX-DEMAND information flow.

Table 15: Elements for the TETRA TX-DEMAND information flow

Element	Request
TX demand priority	O

5.2.1.15 TX-ceased tone

TX-ceased tone is an optional unconfirmed information flow across ra from FE1 to FE2. It shall indicate to the PSTN subscriber that transmission from the talking party has ceased.

A recommendation for a TETRA TX-ceased tone is given in annex D.

5.2.1.16 TX-granted tone

TX-granted tone is an optional unconfirmed information flow across ra from FE1 to FE2. It shall indicate to the PSTN subscriber that the demand for permission to transmit has been granted to the PSTN subscriber.

A recommendation for a TETRA TX-granted tone is given in annex D.

5.2.1.17 TX-interrupt tone

TX-interrupt tone is an optional unconfirmed information flow across ra from FE1 to FE2. It shall indicate to the PSTN subscriber that permission to transmit has been withdrawn.

A recommendation for a TETRA TX-interrupt tone is given in annex D.

5.2.1.18 Unknown destination tone

Unknown destination tone is an optional unconfirmed information flow across ra from FE2 to FE1. Unknown destination shall indicate that the called PSTN subscriber is not a valid PSTN number.

The unknown destination from the PSTN is defined in ETS 300 001 [2] or relevant national requirement not covered by ETS 300 001 [2].

5.2.2 Information flow diagrams

The stage 3 of this ETS for PSTN gateway and ETS 300 001 [2] or relevant national requirement not covered by ETS 300 001 [2] for PSTN shall provide signalling procedures in support of the information flow sequences specified below. In addition, signalling procedures should be provided to cover other sequences arising from error situations, interactions with basic call, interactions with supplementary services, different topologies, etc. See subclauses 4.6.2 and 4.6.3 for informative service primitives.

In the figures, the numbers within a column representing a functional entity refer to functional entity actions listed in subclause 5.3. The following abbreviations are used:

- req: request;
- ind: indication;
- resp: response;
- conf: confirmation.

5.2.2.1 Successful call set-up to a PSTN subscriber using hook signalling

Figure 8 shows a successful information flow sequence for call set-up to a PSTN subscriber with an external subscriber number in the SETUP PDU using a PSTN gateway with hook signalling.

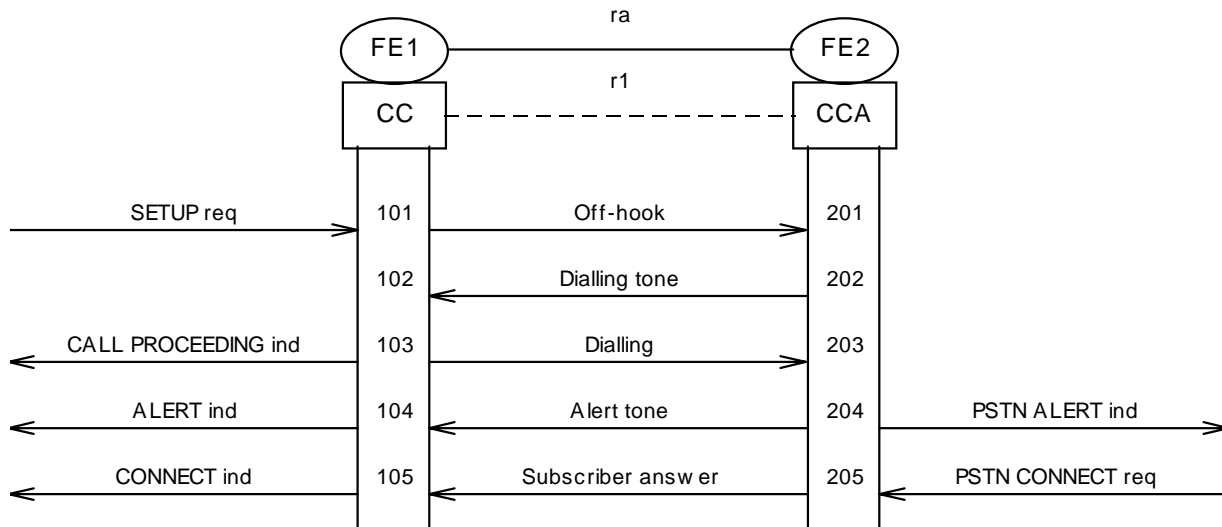

NOTE: Instead of utilising hook signalling the gateway may perform connection completion without waiting for an answer from the PSTN subscriber. In this case some or all of the action 103 to 105 are combined together and only the CONNECT ind is used.

Figure 8: Information flow sequence - successful call set-up to a PSTN subscriber using hook signalling

5.2.2.2 Successful call set-up to a PSTN subscriber using direct call setup

Figure 9 shows a successful information flow sequence for call set-up to a PSTN subscriber with direct call setup using a PSTN gateway. Call to a PSTN exchange is through connected to the TETRA user before the gateway dials the called PSTN number.

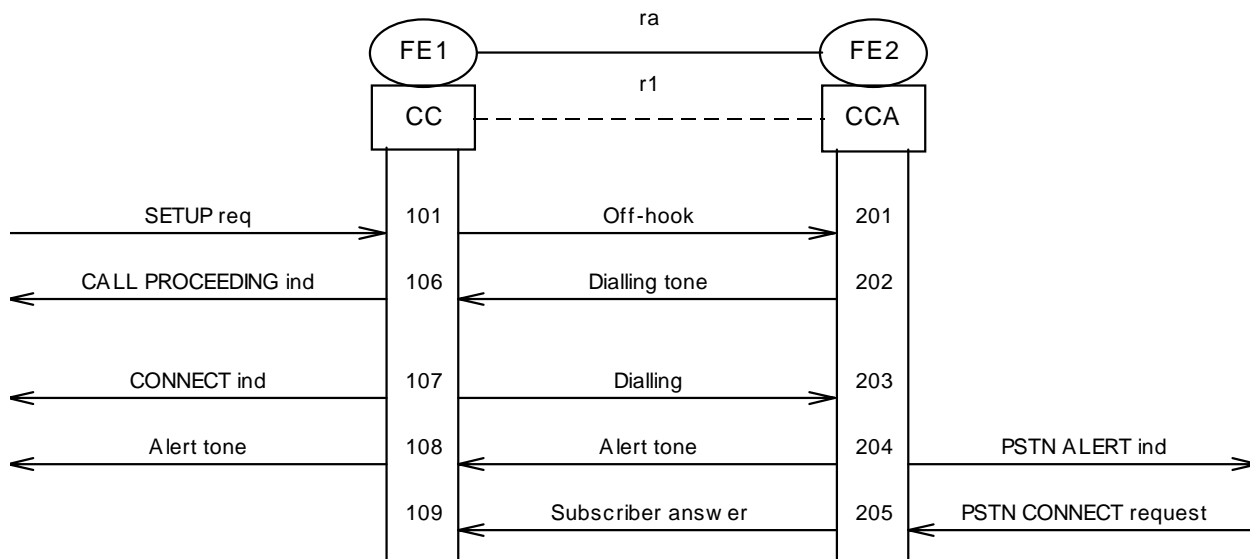
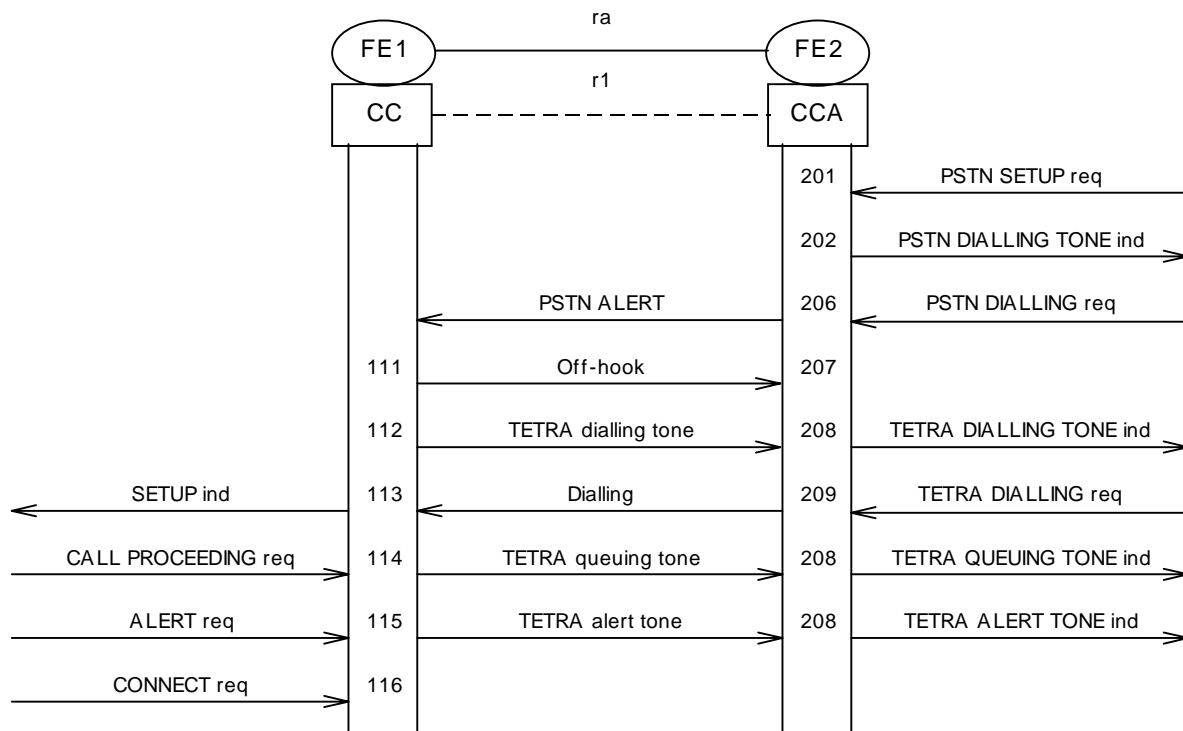

Figure 9: Information flow sequence - successful call set-up to a PSTN subscriber using direct call setup

5.2.2.3 Successful call set-up from a PSTN subscriber over PSTN gateway

Figure 10 shows the information flow sequence for call set-up from a PSTN subscriber using PSTN gateway.



NOTE: At any time FE1 may send FE2 extra information (and vice versa) contained within the information flow INFORM.

Figure 10: Information flow sequence - successful call set-up from a PSTN subscriber

5.2.2.4 Unsuccessful call set-up from TETRA user over PSTN gateway

Figure 11 shows a simplified information flow sequence for an unsuccessful call set-up using PSTN gateway as a result of busy called user or PSTN. It is optional for the PSTN gateway to detect busy tone.

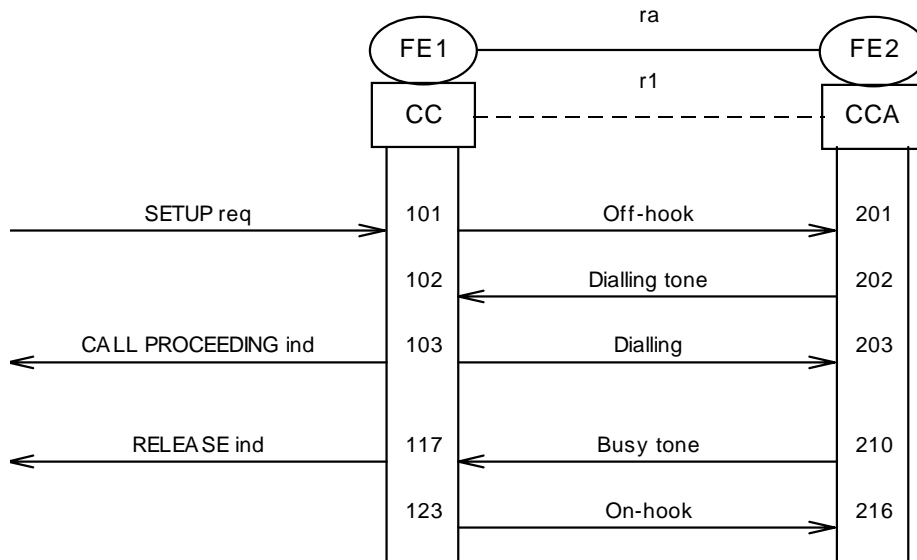

NOTE: There can be also other conditions such as no answer, which should result a disconnection. FE1 may also initiate a call disconnection by an unsolicited RELEASE indication.

Figure 11: Information flow sequence - unsuccessful call set-up - busy called PSTN subscriber

5.2.2.5 Unsuccessful call set-up from a PSTN subscriber over PSTN gateway

Figure 12 shows a simplified information flow sequence for an unsuccessful call set-up using PSTN gateway as a result of busy called TETRA user.

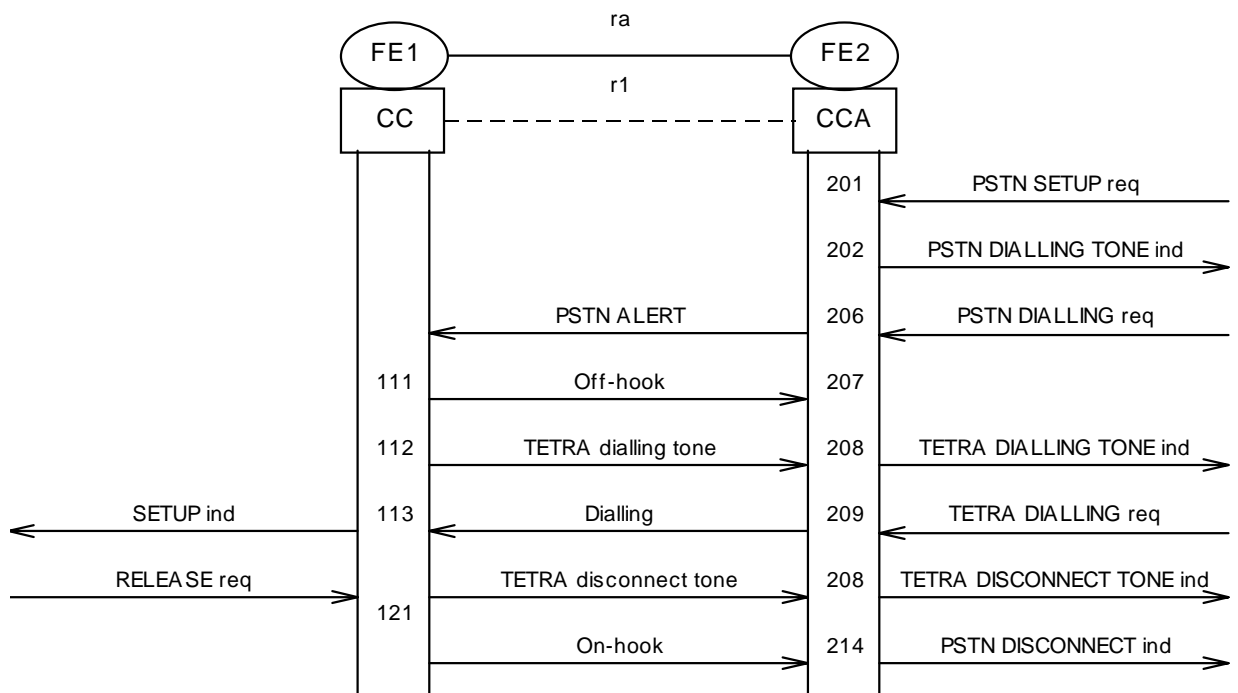

NOTE: There can be also other conditions such as no answer or user not reachable, which will result a disconnection.

Figure 12: Information flow sequence - unsuccessful call set-up - busy called TETRA user

5.2.2.6 Call maintenance procedures - Request to transmit from the PSTN subscriber

Figure 13 shows the information flow sequence for a request to transmit from the PSTN subscriber and the response from the PSTN gateway. This information flow is only applicable in a semi-duplex call. The PSTN subscriber may send a TETRA TX-DEMAND request also before receiving a TETRA TX-CEASED indication and use a higher priority in the request to "force" permission to talk to him.

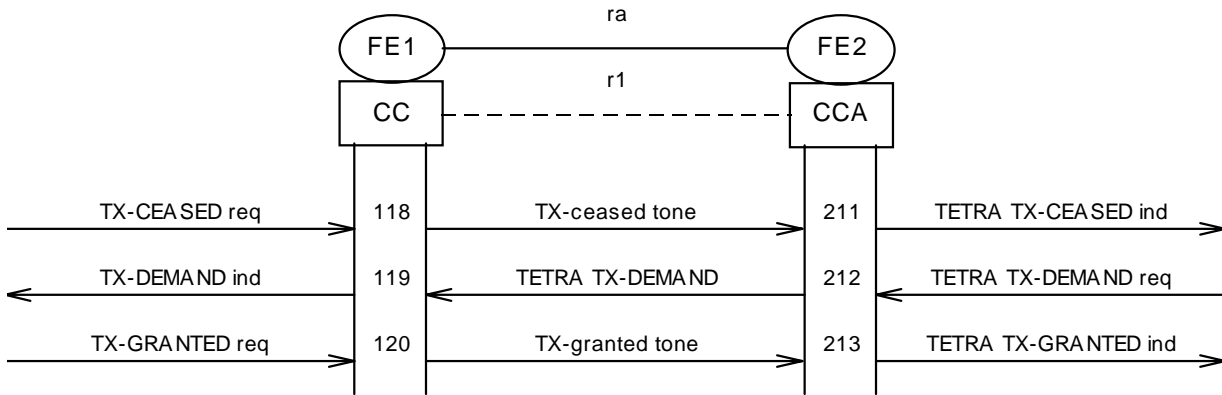

NOTE: The TETRA TX-DEMAND may be replaced by a voice activity detection in action 119.

Figure 13: Information flow sequence - Request to transmit

5.2.2.7 Call maintenance procedures - Request to transmit from a TETRA user

Figure 14 shows the information flow sequence for a request to transmit from a TETRA user. This information flow is only applicable in a semi-duplex call.

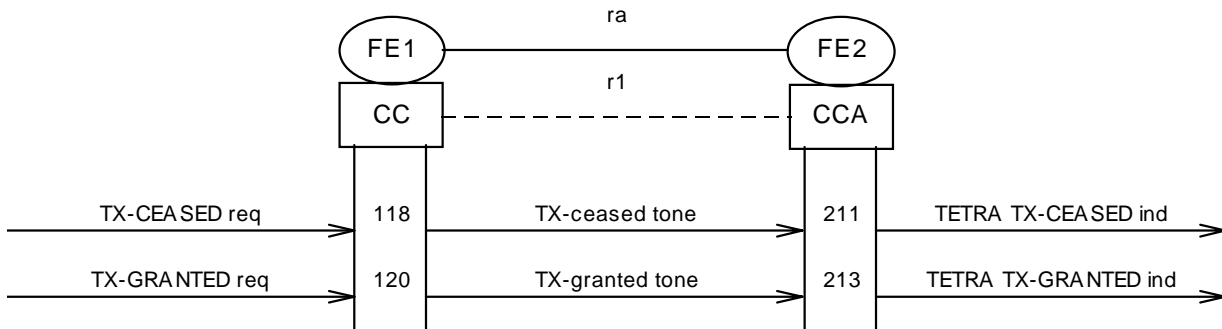

Figure 14: Information flow sequence - Request to transmit from a TETRA user
 5.2.2.8 Call maintenance procedures - Request to interrupt

Figure 15 show information flow, when SwMI removes from the PSTN subscriber permission to transmit in a semi-duplex call.

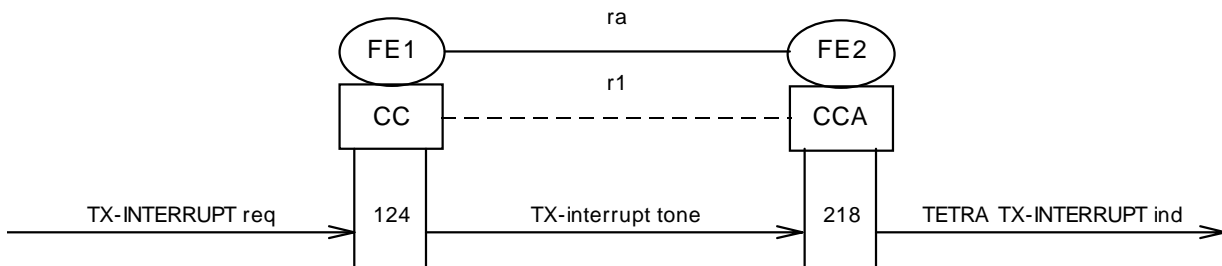

Figure 15: Information flow sequence - Request to interrupt

5.2.2.9 Call maintenance procedures - Request to disconnect from the TETRA user

Figure 16 shows the information flow sequence for a request to disconnect from a TETRA user.

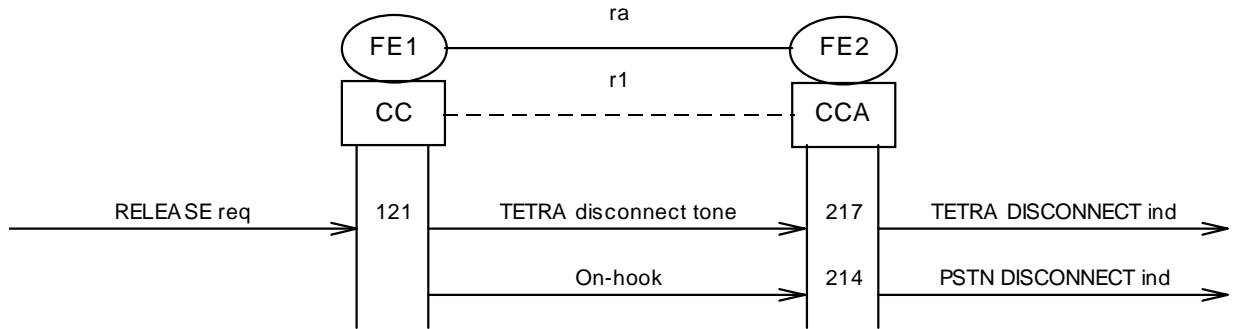
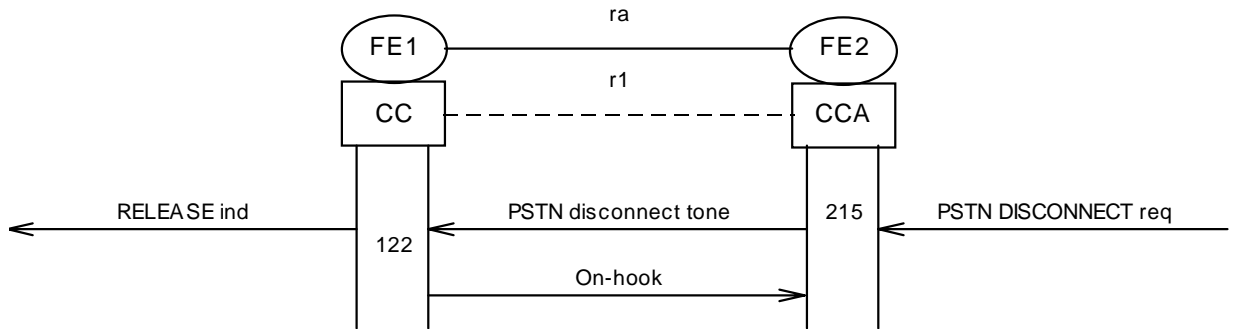

Figure 16: Information flow sequence - Request to disconnect

5.2.2.10 Call maintenance procedures - Request to disconnect from the PSTN subscriber

Figure 17 shows the information flow sequence for a request to disconnect from a PSTN subscriber. It is optional for the PSTN gateway to detect a PSTN disconnect tone.



NOTE: The PSTN disconnect tone or some other equivalent call termination indication may not be available and other means for detection of a call release by the PSTN subscriber may be used or the connection is released by TETRA user release.

Figure 17: Information flow sequence - Request to disconnect

5.2.2.11 Call maintenance procedures - Request to disconnect from the PSTN gateway

Figure 18 shows the information flow sequence for a request to disconnect from the PSTN gateway.

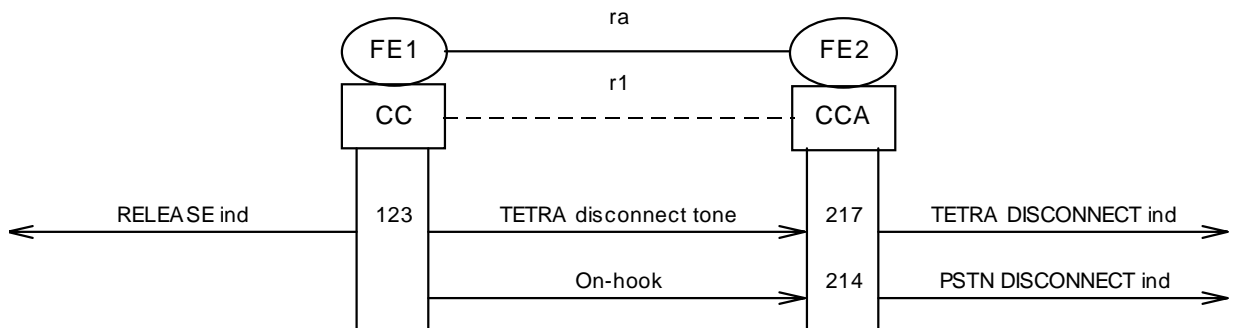

Figure 18: Information flow sequence - Request to disconnect

5.3 Functional entity actions

The following FE actions shall occur at the points indicated in the figures in subclause 5.2.

5.3.1 Functional entity actions of FE1

- 101 FE1 detects an outgoing call and shall go off-hook.
- 102 FE1 detects dialling tone from FE2.
- 103 After detecting the dialling tone FE1 shall send Dialling to FE2 and may send a CALL PROCEEDING indication to SwMI CC.
- 104 FE1 detects an Alert tone and shall send an ALERT indication to SwMI CC. As an option FE1 may generate the ALERT indication by other means.
- 105 FE1 detects a PSTN subscriber answer and shall send CONNECT indication to SwMI CC.
- 106 FE1 detects an outgoing call and may send a CALL PROCEEDING indication to SwMI CC and shall go off-hook.
- 107 FE1 detects a dialling tone from FE2 and shall send a CONNECT indication to SwMI CC. FE1 may send the CONNECT indication to SwMI without waiting for the dialling tone.
- 108 FE1 shall pass alert tone to SwMI.
- 109 FE1 shall pass PSTN subscriber answer to SwMI.
- 111 FE1 detects alert and shall go off-hook.
- 112 FE1 shall send Dialling tone.
- 113 FE1 receives Dialling and shall send corresponding SETUP indication to SwMI CC.
- 114 FE1 receives CALL PROCEEDING request from SwMI CC and shall send Queuing indication, when relevant, to FE2.
- 115 FE1 receives ALERT request from SwMI CC and shall send Alert tone to FE2.
- 116 FE 1 receives CONNECT request from SwMI CC and shall complete call set-up to FE2.
- 117 FE1 detects no answer, when available, and shall send RELEASE indication to SwMI CC.
- 118 FE1 receives TX-CEASED request from SwMI CC and shall send TX-ceased tone to FE2.
- 119 FE1 receives TETRA TX-DEMAND from FE2 and shall send TX-DEMAND indication to SwMI CC.
- 120 FE1 receives TX-GRANTED request from SwMI CC and shall send TX-granted tone to FE2.
- 121 FE1 receives RELEASE request from SwMI CC and may send a TETRA disconnect tone and shall go on-hook and release the existing call, if any.
- 122 FE1 detects PSTN disconnect tone and shall disconnect the call, if any, by sending a RELEASE indication to SwMI CC and shall go on-hook on the PSTN line.
- 123 FE1 detects busy or any other reason for disconnection and shall send a RELEASE indication to SwMI and go on-hook on the PSTN line.
- 124 FE1 detects TX-INTERRUPT request from SwMI CC and may send TX-interrupt tone to FE2.

5.3.2 Functional entity actions of FE2

- 201 FE2 detects Off-hook.
- 202 FE2 sends Dialling tone.
- 203 FE2 detects Dialling and set-up a call to the dialled number.

- 204 FE2 detects PSTN subscriber alerting and sends Alert tone to FE1.
- 205 FE2 detects PSTN subscriber answer and completes connection to FE1.
- 206 FE2 detects a call to a TETRA system and alerts FE1.
- 207 FE2 detects gateway answer, stops alerting.
- 208 FE2 passes notification to the PSTN subscriber.
- 209 FE2 passes Dialling to FE1.
- 210 FE2 detects busy condition on send busy tone to FE1.
- 211 FE2 detects TX-ceased tone.
- 212 FE2 detects transmission request situation and sends TX-DEMAND to FE1.
- 213 FE2 detects TX-granted tone and starts transmission.
- 214 FE2 detects incoming on-hook and may disconnect the PSTN call.
- 215 FE2 detects outgoing on-hook from the PSTN subscriber and should send PSTN disconnect tone to FE1.
- 216 FE2 detects on hook conditions and releases the call set-up attempt.
- 217 FE2 detects TETRA disconnect tone and should go on-hook on the PSTN line.
- 218 FE2 detects TX-interrupted tone and ceases to transmit.

5.4 Allocation of functional entities to physical equipment

PSTN gateway functional entity FE1 shall be allocated to a SwMI and FE2 to the PSTN and PSTN subscriber.

5.5 Inter-working considerations

There shall be no interaction between a PSTN gateway and the TETRA Inter-System Interface (ISI).

6 PSTN gateway stage 3 specification

6.1 Protocol structure and protocol stack

Figure 19 shows the protocol stack of the PSTN gateway. The signalling between SwMI and PSTN shall use PSTN signalling as specified for each country in ETS 300 001 [2] or relevant national requirement not covered by ETS 300 001 [2]. The information exchange between SwMI and the PSTN subscriber shall use DTMF signalling. This ETS is only normative for the signalling protocol architecture and signalling between a PSTN subscriber and TETRA SwMI, but gives an informative description of the protocol and the SAPs within the SwMI.

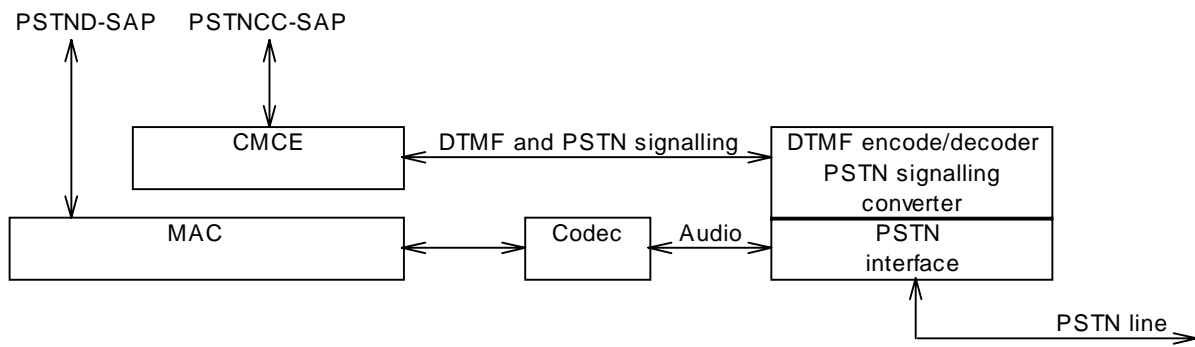

Figure 19: PSTN gateway protocol stack

6.2 Protocol Data Unit (PDU) descriptions

The PDUs between PSTN gateway and a PSTN subscriber are using either PSTN low level signalling, simple tones or sequences of DTMF tones.

The information contained in the following argument description tables correspond to the following key:

- C/O/M: conditional/optional/mandatory;
- Remark: comment.

6.2.1 Alert tone

See ETS 300 001 [2] or relevant national requirement not covered by ETS 300 001 [2] for alert tone used in PSTN.

6.2.2 Busy tone

See ETS 300 001 [2] or relevant national requirement not covered by ETS 300 001 [2] for alert tone used in PSTN.

6.2.3 Dialling

For incoming calls the second set of the two set dialling consists of a sequence of DTMF digits representing the dialled TETRA user number. The PSTN subscriber shall use DTMF signalling for the second set of the two step dialling either using a telephone set equipped with a DTMF generator or any external DTMF generating device. The TETRA gateway shall apply the same DTMF tone and pause lengths as defined in ETS 300 001 [2] or relevant national requirement not covered by ETS 300 001 [2].

For outgoing calls the gateway may use either DTMF or pulse dialling of the called PSTN subscriber depending on the PSTN capabilities as defined in ETS 300 001 [2] or relevant national requirement not covered by ETS 300 001 [2].

In addition to the dialled number, the dialling may contain additional elements for service selection, see annexes B and C. The selection of PSTN services such as supplementary services are outside the scope of this ETS.

6.2.4 Dialling tone

See ETS 300 001 [2] or relevant national requirement not covered by ETS 300 001 [2] for dialling tone used in PSTN.

6.2.5 Off-hook

The PSTN subscriber line loop current is not flowing in this signal state. This signal shall comply to the requirements in ETS 300 001 [2] or relevant national requirement not covered by ETS 300 001 [2].

6.2.6 On-hook

The PSTN subscriber line loop current is flowing in this signal state. This signal shall comply to the requirements in ETS 300 001 [2] or relevant national requirement not covered by ETS 300 001 [2].

6.2.7 PSTN ALERT

This signal is normal ringing current of PSTN. This signal shall comply to the requirements in ETS 300 001 [2] or relevant national requirement not covered by ETS 300 001 [2].

6.2.8 PSTN disconnect tone

See ETS 300 001 [2] or relevant national requirement not covered by ETS 300 001 [2] for disconnect tone used in PSTN.

6.2.9 Subscriber answer

This indication may be available at the PSTN line access point as defined in ETS 300 001 [2] or relevant national requirement not covered by ETS 300 001 [2].

6.2.10 TETRA alert tone

See annex D for alert tone recommended for TETRA.

6.2.11 TETRA busy tone

See annex D for busy tone recommended for TETRA.

6.2.12 TETRA dialling tone

See annex D for dialling tone recommended for TETRA.

6.2.13 TETRA disconnect tone

See annex D for disconnect tone recommended for TETRA.

6.2.14 TETRA invalid number tone

See annex D for invalid number tone recommended for TETRA.

6.2.15 TETRA queuing tone

See annex D for queuing tone recommended for TETRA.

6.2.16 TX-DEMAND

This optional PDU shall carry a transmission permission request from the PSTN subscriber. This PDU shall contain DTMF digits as defined in table 16.

Table 16: TX-DEMAND PDU contents

Element	Length	Value	Remark
TX-demand	4	*759	Normal priority request
		*752	High priority request
		*751	Pre-emptive priority request
		*750	Emergency priority request

6.2.17 TX-ceased tone

See annex D for TX-ceased tone recommended for TETRA.

6.2.18 TX-granted tone

See annex D for TX-granted tone recommended for TETRA.

6.2.19 TX-interrupt tone

See annex D for TX-interrupt tone recommended for TETRA.

6.3 PSTN GATEWAY Functional Entity FE1 behaviour

The figures contained in this subclause are intended to illustrate typical PSTN gateway behaviour in terms of information flows sent and received.

The behaviour of each FE is shown using the Specification and Description Language (SDL) defined in ITU-T Recommendation Z.100 [3]. Notice, however, that due to simplicity there may be deviations from syntactical rules.

Input signals from the right originates from the TETRA SwMI or TETRA user actions and output signals to the right are towards to the TETRA user. Input signals from the left are from the PSTN subscriber and output signals to the left are towards the PSTN user. The SDL models describe a semi-duplex call. For a full-duplex call the call maintenance is limited into the disconnection function and states PSTN receiving and PSTN transmitting are merged together.

6.3.1 PSTN gateway FE1 protocol states

This ETS describes one instance of a call through the PSTN gateway. At the SwMI side of the gateway a call is identified by a call identifier.

The states used in the description are:

- IDLE:
 - PSTN gateway is ready to accept call invocations;
- PSTN RECEIVING:
 - TETRA user has permission to transmit;
- PSTN SENDING:
 - PSTN user has permission to transmit;
- WAIT ANSWER:
 - PSTN gateway is waiting TETRA user answer;
- WAIT PSTN ANSWER:
 - PSTN gateway is ready to accept PSTN subscriber answer; and
- WAIT TETRA DIALLING:
 - PSTN gateway is waiting dialling of a TETRA number.

6.3.2 Protocol timers for FE1

The PSTN gateway FE1 shall take into account protocol timers defined in the air interface protocol in ETS 300 392 2 [1], clause 14. The timers T301-T303 may need to use extended values compared to the air interface MS to MS call set-up values as the PSTN call set-up may take an extended period of time.

The management of timers is outside the scope of this ETS.

6.3.3 Procedures of FE1

Check restrictions procedure assumes that verification whether either TETRA or PSTN user is allowed to make a call is checked either by call control or by supplementary services and PSTN gateway as such does not add any actions.

6.3.4 Behaviour of FE1

The PSTN gateway shall behave as defined in figures 20, 21, 22 and 23. In addition to protocols defined in figures 20, 21, 22 and 23 the PSTN gateway should contain procedures for exceptional situations, which are not defined in this ETS.

In duplex services the PSTN RECEIVING and PSTN SENDING states are merged together and present in effect state ACTIVE.

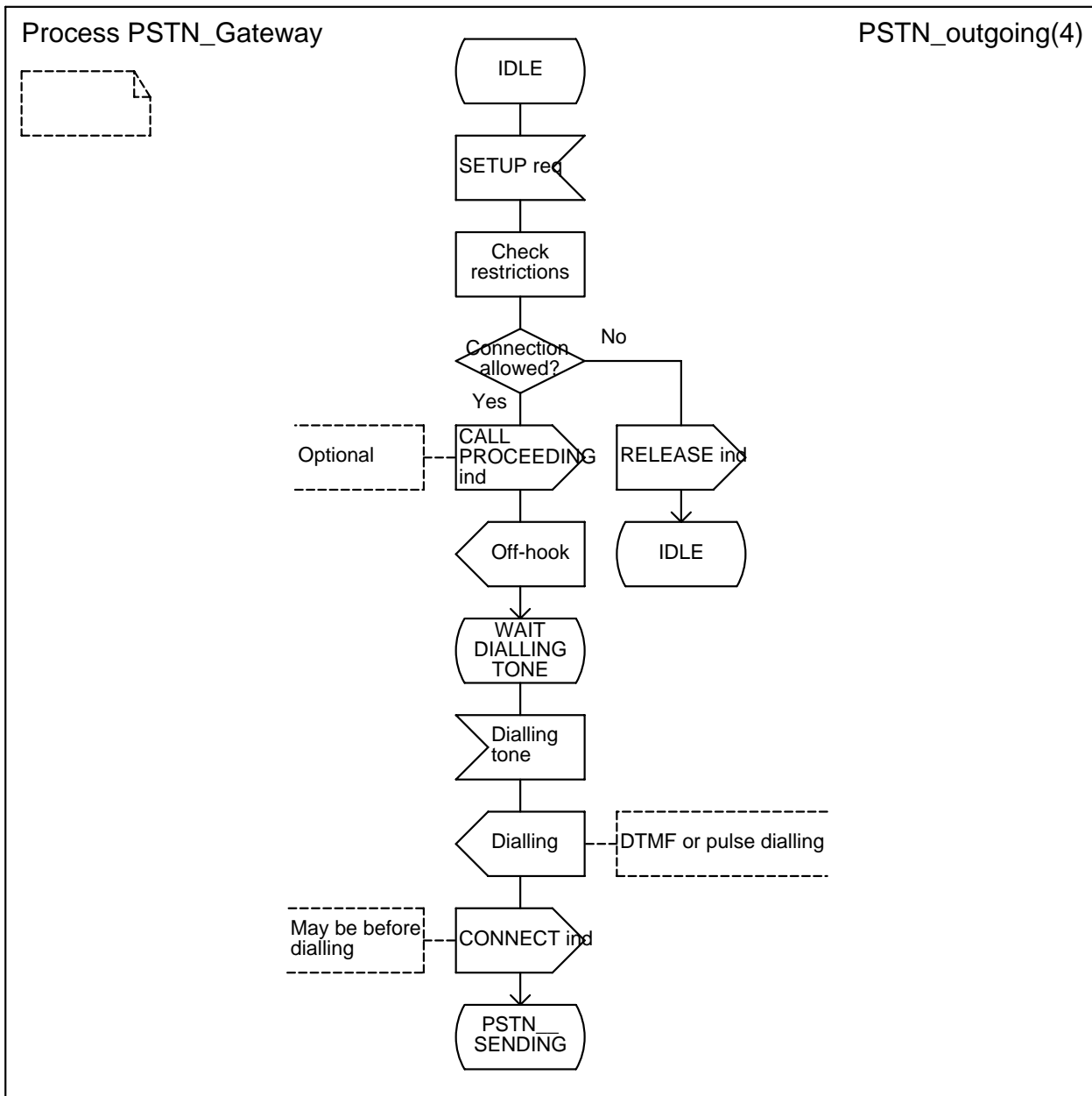

Figure 20: Outgoing call, direct call setup to the PSTN gateway

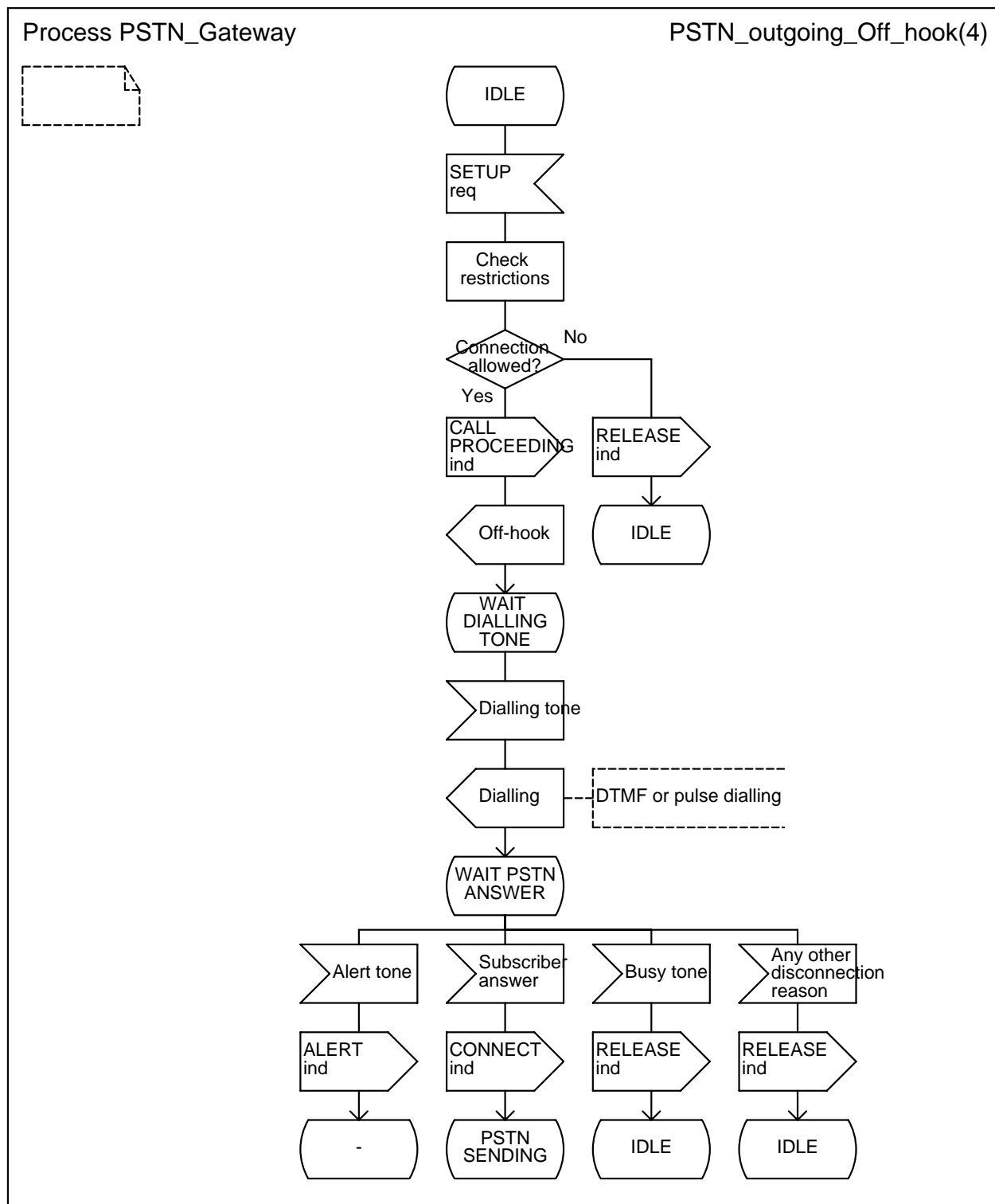

Figure 21: Outgoing call, with hook signalling

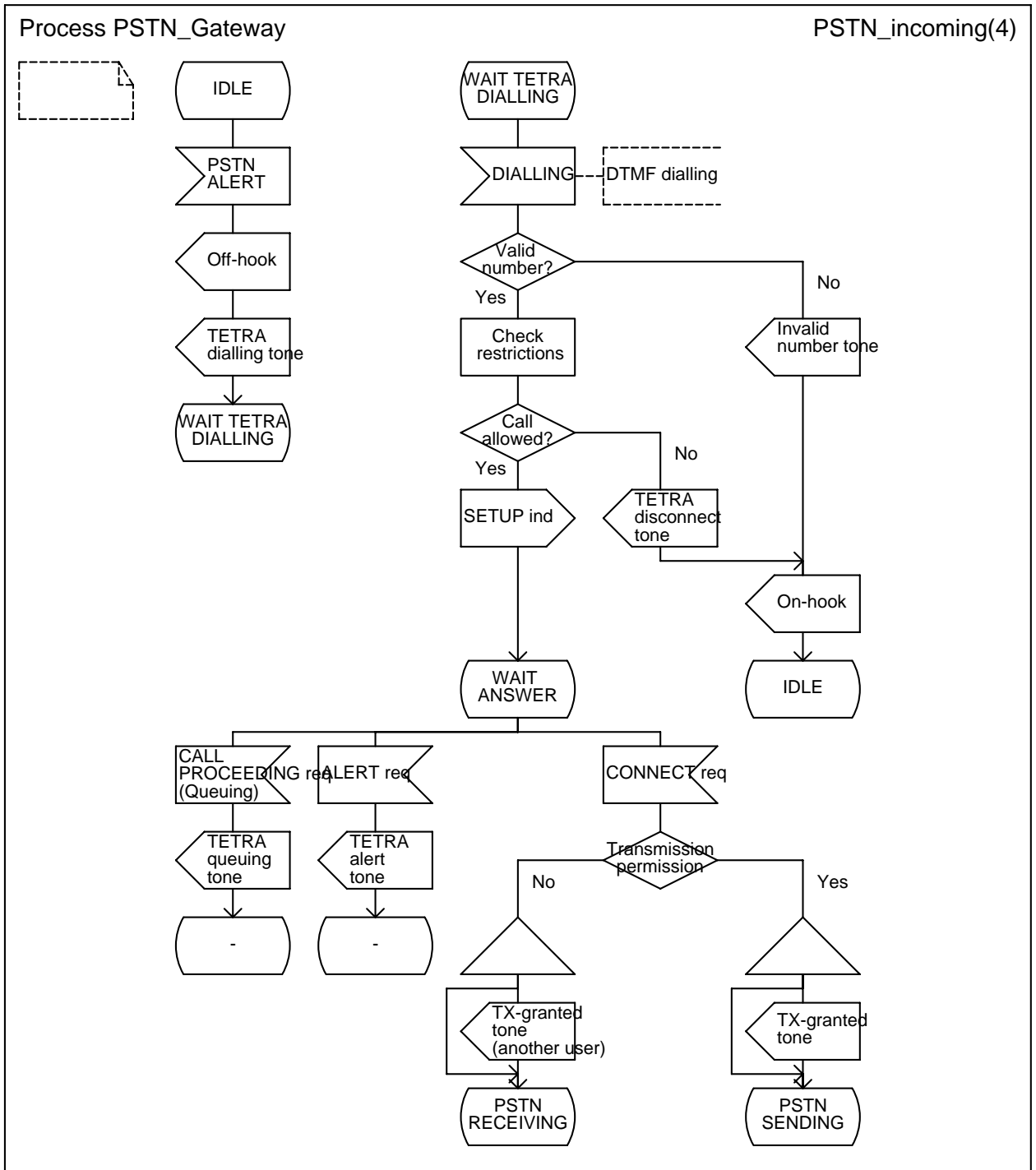

Figure 22: Incoming call

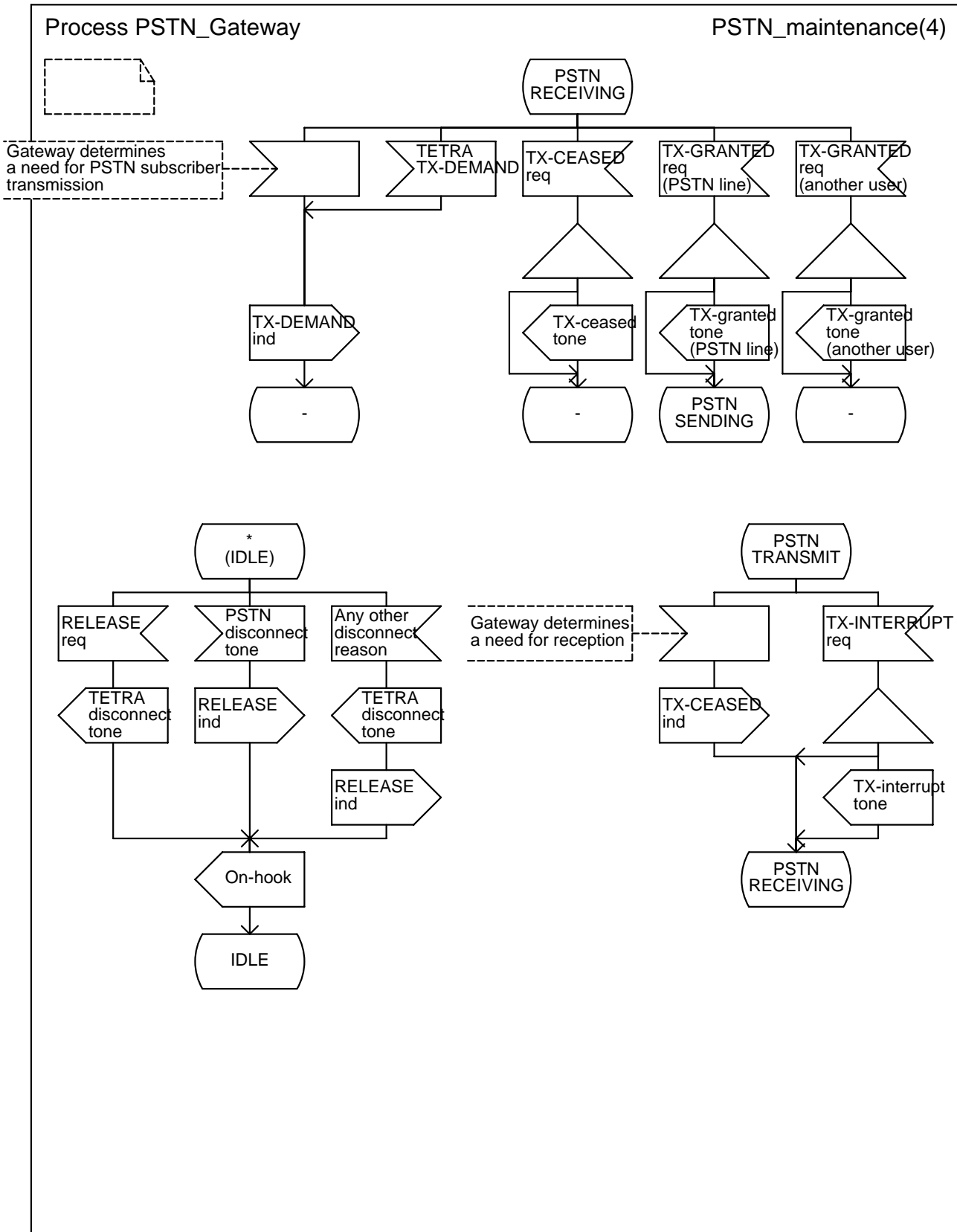

Figure 23: Call maintenance

As in the duplex services the PSTN RECEIVING and PSTN SENDING states are merged together the transmission permission functions are redundant in figures 20, 21, 22 and 23 and the only valid issues in figure 23 is the disconnection procedure.

6.4 PSTN and PSTN subscriber Functional Entity FE2 behaviour

The behaviour of FE2 (PSTN and PSTN user) is mainly outside the scope of this ETS. This information is normative only on the signalling to the TETRA network, see annex A.

This ETS utilises PSTN features without setting new requirements or functions to PSTN protocols. For presentation purposes two generic states are defined:

- IDLE; and
- ACTIVE.

6.4.1 State IDLE

In the IDLE state FE2 is ready for setting a PSTN call between PSTN user and TETRA PSTN gateway.

6.4.2 State ACTIVE

In the ACTIVE state FE2 maintains the ongoing call and disconnects the call as requested by the PSTN user or PSTN gateway. In that state PSTN should also transparently transfer DTMF signalling between the PSTN user and the PSTN gateway.

Annex A (informative): Dialling for TETRA basic call

A PSTN subscriber can dial TETRA basic call using two step dialling. In this case the subscriber should first dial a TETRA PSTN gateway number, wait for a TETRA dialling tone and then dial the TETRA Short Subscriber Identity (SSI) using DTMF signalling (digits). The TETRA PSTN gateway number defines the country code and the network code of the called TETRA user identity, see ETS 300 392-1 [8], clause 7. The basic call dialling without invocation of any supplementary services is a sequence of digits presenting the destination number. Depending on the TETRA network there may be a time limitation between individual digits or over the whole number.

The translation between a dialled TETRA number and the corresponding TETRA identity is a direct conversion from the dialled decimal number into a binary number of the same value. The possible number range is from 1 to $2^{24} - 1$ (16 777 216) for TETRA users in one system (SwMI). As an network option the PSTN gateway may perform a number analysis before the conversion.

Annex B (informative): TETRA supplementary services

In order to control and gain access to the TETRA supplementary services it is envisaged that the PSTN subscriber employs the Service Code Command Format (SCCF) as described in ETS 300 738 [6]. Supplementary services are invoked by entering star-hash combinations and digits as defined table 1 and in annex A in that document.

The Service Code Command (SCC) used by the PSTN subscriber to gain access to, and control of, TETRA supplementary services should have the following syntax as the TETRA supplementary services are controlled during an active PSTN call:

"PX SC (SR SI) SX FINISH"

Where:

- PX is a mandatory service prefix;
- SC is a mandatory service code;
- SR is one or more separator/s, as required;
- SI is one or more units of supplementary information, as required;
- SX is a service suffix, as required;
- FINISH is a finish command, when applicable.

NOTE 1: The SX service suffix is normally required as the FINISH command applicable only in the form of "on-hook", when the PSTN subscriber disconnects the PSTN call while completing a TETRA supplementary service request.

Where units of supplementary information are required, each unit of supplementary information should be preceded by a separator. The number of supplementary information units that can be included within a single command sequence is at the discretion of the terminal, network, or service provider.

NOTE 2: Services which require more than two supplementary information units may be better supported by the interactive dialogue format, see ETS 300 738 [6], subclause 6.2.

The switching order invocation of TETRA supplementary services as defined in ETS 300 738 [6], subclause 6.1.2.1 is not applicable as it would interact with the PSTN supplementary services.

The abbreviated dialling command for access to an abbreviated dialling service to dial TETRA identities where a TETRA user identity is stored within the PSTN gateway should have the following syntax:

"AN SX"

Where:

- AN is a mandatory abbreviated number; and
- SX is a mandatory service suffix.

Refer to ETS 300 738 [6], subclause 6.1.3 for further details.

Annex C (informative): Call modifiers

In order to control and gain access to the TETRA services outside the basic call it is envisaged that the PSTN subscriber employs same kinds of procedures as the SCCF as described in ETS 300 738 [6]. The command codes are outside the scope of this ETS.

Annex D (informative): Guidance tones

Recommendations on how to define guidance tones for a telephone service are given in ITU-T Recommendation E.180 [5]. The electrical levels for tones should be according to that recommendation. The following guidance (supervisory) tones from a TETRA system to PSTN subscribers are recommended to guide a PSTN subscriber calling to a TETRA user or called by a TETRA user:

D.1 TETRA alert tone

Indication to PSTN subscriber that TETRA user is alerted:

- 425 Hz for 1 s followed by 4 s pause repeated.

D.2 TETRA busy tone

Indication to PSTN subscriber that TETRA user is busy and call cannot be set-up:

- 425 Hz for 500 ms followed by 500 ms pause repeated.

D.3 TETRA called party not available

- 425 Hz for 1 s followed by 1 s pause repeated.

D.4 TETRA congestion tone

- 425 Hz for 250 ms followed by 250 ms pause repeated.

D.5 TETRA dialling tone

Invitation to PSTN subscriber to dial a TETRA identity:

- 425 Hz or 350 Hz and 425 Hz continuous.

The latter may give to the PSTN user a better guidance as it is not the same as the normal PSTN dialling tone.

D.6 TETRA disconnect tone

Indication to PSTN subscriber that a call has been released or a call attempt rejected:

- 425 Hz for 500 ms followed by 500 ms pause repeated.

D.7 TETRA invalid number tone

Indication to PSTN subscriber that the dialled TETRA identity is unknown:

- 425 Hz for 3 s followed by 500 ms pause repeated.

D.8 TETRA queuing tone

Indication to PSTN subscriber that TETRA call set-up or call is queued:

- 950 Hz for 600 ms followed by 300 ms pause followed by 950 Hz for 300 ms followed by 1 400 Hz for 1,2 s followed by 3 s pause repeated.

D.9 TX-ceased tone

Indication to the PSTN subscriber that talking party has ceased to talk:

- 425 Hz for 200 ms.

D.10 TX-granted tone

This tone has two variants to indicate to whom the permission to talk is granted:

- permission to talk granted to PSTN subscriber:
 - 425 Hz for 100 ms followed by 100 ms pause followed by 425 Hz for 100 ms; and
- permission to talk granted to another user:
 - 425 Hz for 300 ms.

D.11 TX-interrupt tone

Indication to the talking PSTN subscriber that permission to talk has been withdrawn:

- 900 Hz for 300 ms followed by 300 ms pause repeated three times.

History

Document history	
December 1997	Public Enquiry PE 9817: 1997-12-26 to 1998-04-24
October 1998	Vote V 9850: 1998-10-13 to 1998-12-11