



EUROPEAN
TELECOMMUNICATION
STANDARD

DRAFT
pr **ETS 300 392-3-1**

February 1998

Source: TETRA

Reference: DE/TETRA-03001-03-1

ICS: 33.020

Key words: TETRA, V+D

**Terrestrial Trunked Radio (TETRA);
Voice plus Data (V + D);
Part 3: Inter-working at the Inter-System Interface (ISI);
Sub-part 1: General design**

ETSI

European Telecommunications Standards Institute

ETSI Secretariat

Postal address: F-06921 Sophia Antipolis CEDEX - FRANCE

Office address: 650 Route des Lucioles - Sophia Antipolis - Valbonne - FRANCE

X.400: c=fr, a=atlas, p=etsi, s=secretariat - **Internet:** secretariat@etsi.fr

Tel.: +33 4 92 94 42 00 - Fax: +33 4 93 65 47 16

Copyright Notification: No part may be reproduced except as authorized by written permission. The copyright and the foregoing restriction extend to reproduction in all media.

© European Telecommunications Standards Institute 1998. All rights reserved.

Contents

Foreword	5
1 Scope	7
2 Normative references	7
3 Definitions and abbreviations	8
3.1 Definitions	8
3.2 Abbreviations	9
4 ISI standardization methodology	10
4.1 3 stage methodology	10
4.1.1 Stage 1	10
4.1.2 Stage 2	11
4.1.3 Stage 3	11
4.2 Usage of Specification and Description Language (SDL)	11
5 Usage of Private Signalling System 1 (PSS1) for TETRA	12
5.1 PSS1 functionality	12
5.2 Protocol stack	12
5.3 Generic Functional Protocol (GFP)	13
6 TETRA SwMI roles using ISI	13
6.1 Management configurations	13
6.1.1 Migration and group attachment configurations	13
6.1.1.1 SwMI roles for migration and group attachment	13
6.1.1.2 SwMI databases	13
6.1.1.3 Migration scenarios	14
6.1.1.4 Group attachment scenarios	16
6.1.2 Group linking configurations	16
6.2 Call configurations	17
6.2.1 Group call configuration	18
6.2.2 Individual call configuration	19
6.2.3 Transit	20
6.2.4 User information encoding at the ISI	20
7 Introduction to ISI ANFs	20
7.1 ANF-ISIMM	21
7.2 ANF-ISIIC	21
7.3 ANF-ISIGC	21
7.4 ANF-ISISDS	21
7.5 ANF-ISISS	21
8 ISI Generic Functional Protocol (ISI GFP)	21
8.1 Protocol model	21
8.2 Services provided by the protocol model entities	22
8.3 Addressing and routing	23
8.3.1 Addressing	23
8.3.2 Routing of ROSE APDUs	24
8.3.2.1 Call related ROSE APDUs	24
8.3.2.2 Call unrelated ROSE APDUs	24
8.3.2.2.1 Establishment of a call independent signalling connection	24
8.3.2.2.2 Use of a call independent signalling connection already established	26
8.4 Remote Operations Service Entity (ROSE) requirements and operation definition	27

8.4.1	General	27
8.4.2	Return-result	29
8.4.3	Return-error	30
8.4.4	Reject.....	31
8.5	Segmentation Service Entity (SSE).....	33
8.5.1	Procedures	33
8.5.1.1	Requirements for the segmentation procedure	33
8.5.1.2	Requirements for the re-assembly procedure	34
8.5.2	Segment encoding.....	34
8.6	Co-ordination function	36
9	Security over the ISI.....	36
9.1	ITSI authentication	36
9.2	End-to-End encryption.....	37
9.3	End-to-end key management via ISI.....	37
Annex A (normative):	Security - supporting encryption over ISI	38
A.1	Overview.....	38
A.2	Encryption.....	39
A.2.1	ISI relation to air interface and end-to-end encryption	39
A.2.2	Air interface encryption key management via ISI.....	39
A.2.2.1	Secret Key of individual subscriber (K).....	40
A.2.2.2	Derived Cipher Key (DCK).....	40
A.2.2.3	Common Cipher Key (CCK)	40
A.2.2.4	Static Cipher Key (SCK)	40
A.2.2.5	Group Cipher Key (GCK).....	40
Annex B (informative):	Maximum length of a ROSE APDU or a SSE segment encoded in a facility information element	41
B.1	Call unrelated PSS1 FACILITY message.....	41
B.2	Call related PSS1 FACILITY message.....	42
B.3	ANF-ISIIC PSS1 basic call message.....	42
History		44

Foreword

This draft European Telecommunication Standard (ETS) has been produced by the Terrestrial Trunked Radio (TETRA) Project of the European Telecommunications Standards Institute (ETSI), and is now submitted for the Public Enquiry phase of the ETSI standards approval procedure.

This ETS consists of 14 parts as follows:

- Part 1: "General network design".
- Part 2: "Air Interface (AI)".
- Part 3: "Inter-System Inter-face (ISI)".**
- Part 4: "Gateways".
- Part 5: "Peripheral Equipment Interface (PEI)".
- Part 6: "Line connected Station (LS)", (DE/TETRA-03001-6).
- Part 7: "Security".
- Part 9: "General requirements for Supplementary Services (SS)".
- Part 10: "Supplementary Services (SS) stage 1".
- Part 11: "Supplementary Services (SS) stage 2".
- Part 12: "Supplementary Services (SS) stage 3".
- Part 13: "SDL model of the Air Interface (AI)".
- Part 14: "Protocol Implementation Conformance Statement (PICS) proforma specification".

Proposed transposition dates	
Date of latest announcement of this ETS (doa):	3 months after ETSI publication
Date of latest publication of new National Standard or endorsement of this ETS (dop/e):	6 months after doa
Date of withdrawal of any conflicting National Standard (dow):	6 months after doa

Blank page

1 Scope

This ETS defines the Terrestrial Trunked Radio (TETRA) system supporting Voice plus Data (V+D). It specifies:

- general design aspects (e.g. reference points, numbering and addressing, or protocol architecture);
- the system bearer and mobility management services, and the corresponding air interface protocols;
- the inter-working between TETRA networks;
- the inter-working of TETRA networks with other networks, via gateways;
- the peripheral equipment interface on the mobile station;
- the Line Station (LS) interface with TETRA networks;
- the security protocols and mechanisms applicable to TETRA networks and to TETRA terminal equipment;
- the supplementary services applicable to the basic TETRA tele- or bearer services.

This part defines the inter-working between TETRA networks over the corresponding interface, the Inter-System Interface (ISI). It comprises the following sub-parts:

- ISI general design;
- Additional Network Feature - ISI Mobility Management (ANF-ISIMM);
- Additional Network Feature - ISI Individual Call (ANF-ISIIC);
- Additional Network Feature - ISI Group Call (ANF-ISIGC);
- Additional Network Feature - ISI Short Data service (ANF-ISISD);
- 8 kbit/s encoding of user information at the ISI.

This sub-part contains the ISI General Design sub-part.

It specifies the general concepts which are the basis of the ISI operation between TETRA systems. It introduces the Additional Network Features (ANFs) used at the ISI, and specifies:

- the general protocol mechanism, called ISI Generic Functional Protocol (ISI GFP), upon which the definition of each ANF is based; and
- the security requirements for the ISI.

The ISI GFP specification applies to any TETRA Switching and Management Infrastructure (SwMI) which supports the ISI. The security requirements for the ISI only apply to SwMIs which support authentication or encryption over the ISI.

2 Normative references

This European Telecommunication Standard (ETS) incorporates, by dated or undated reference, provisions from other publications. These references are cited at the appropriate places in the text and the publications are listed hereafter. For dated references, subsequent amendments to or revisions of any of these publications apply to this European Telecommunication Standard only when incorporated in it by amendment or revision. For undated references the latest edition of the publication referred to applies.

- [1] CCITT Recommendation I.130 (1988): "Method for the characterization of telecommunication services supported by an ISDN and network capabilities of an ISDN".

- [2] ITU-T Recommendation Z.100 (1993): "CCITT specification and description language (SDL)".
- [3] ISO/IEC 11572 (1997): "Information technology - Telecommunications and information exchange between systems - Private Integrated Services Network - Circuit mode bearer services - Inter-exchange signalling procedures and protocol".
- [4] ISO/IEC 11582 (1995): "Information technology - Telecommunications and information exchange between systems - Private Integrated Services Network - Generic functional protocol for the support of supplementary services - Inter-exchange signalling procedures and protocol".
- [5] ETS 300 392-1: "Radio Equipment and Systems; Trans-European Trunked Radio (TETRA); Voice plus Data (V+D); Part 1: General Network Design".
- [6] CCITT Recommendation I.460 (1988): "Multiplexing, rate adaption and support of existing interfaces".
- [7] ETS 300 392-2: "Radio Equipment and Systems (RES) - Trans-European Trunked Radio; Voice plus Data (V+D); Part 2: Air Interface (AI)".
- [8] ETS 300 392-7: "Radio Equipment and Systems (RES) - Trans-European Trunked Radio (TETRA); Voice plus Data (V+D); Part 7: Security".
- [9] CCITT Recommendation X.219 (1988): "Remote operations: Model, notation and service definition".
- [10] CCITT Recommendation X.229 (1988): "Remote operations: Protocol specification".
- [11] CCITT Recommendation X.209 (1988): "Specification of basic encoding rules for Abstract Syntax Notation One (ASN.1)".
- [12] ETS 300 395-1: "Terrestrial Trunked Radio (TETRA); Speech CODEC for full-rate traffic channel; Part 1: General description of speech functions".
- [13] ETS 300 402-1: "Integrated Services Digital Network (ISDN); Digital Subscriber Signalling System No. one (DSS1) protocol; Data link layer; Part 1: General aspects [ITU-T Recommendation Q.920 (1993), modified]".
- [14] ETS 300 402-2: "Integrated Services Digital Network (ISDN); Digital Subscriber Signalling System No. one (DSS1) protocol; Data link layer; Part 2: General protocol specification [ITU-T Recommendation Q.921 (1993), modified]".
- [15] prETS 300 392-9: "Terrestrial Trunked Radio (TETRA) - Voice plus Data (V+D); General requirements for Supplementary Services (SS)".

3 Definitions and abbreviations

3.1 Definitions

For the purposes of this ETS, the following definitions apply:

call: The instance of the use of a bearer or tele-service.

Group TETRA Subscriber Identity (GTSI): A TETRA Subscriber Identity assigned to a group.

Location Area (LA): The area within radio coverage of a base station or group of base stations within which a Mobile Station (MS) is allowed to operate.

Mobile Network Identity (MNI): The identity that is broadcast by all TETRA base stations to uniquely identify the SwMI. It consists of the Mobile Country Code (MNC) and the Mobile Network Code (MNC).

Mobile Station (MS): A physical grouping that contains all of the mobile equipment that is used to obtain TETRA services. By definition, a mobile station contains at least one Mobile Radio Stack (MRS).

segmentation: The act of generating two or more PDUs derived from an initial one.

service user: An abstract representation of the totality of those entities in a single system that make use of a service through a single access point.

supplementary service: A supplementary service modifies or supplements a basic bearer service or a basic teleservice. A supplementary service cannot be offered to a customer as a stand-alone service. It should be offered in combination with a bearer service or a teleservice.

Switching and Management Infrastructure (SwMI): All of the TETRA equipment for a Voice plus Data (V+D) network. The SwMI enables users to communicate with each other via the SwMI.

Short Subscriber Identity (SSI): The network specific portion of a TSI. A SSI is only unique within one TETRA sub-domain (one TETRA network).

TETRA Subscriber Identity (TSI): A global TETRA network address that is to identify an individual or a group subscriber within the domain of all TETRA networks. A valid TSI refers to a TSI that has been allocated by the network where it is being used.

subscriber: A user of a telecommunication service, based on a contract with the provider of the service. The subscriber is identified by an ITSI or GTSI.

NOTE 1: The subscriber is able to access the SwMI either through a MS or Line Station.

user: An entity using the services of a telecommunications network via an externally accessible service access point.

NOTE 2: A user may be a person or an application process.

3.2 Abbreviations

For the purposes of this ETS, the following abbreviations apply:

AC	Authentication Centre
ACSE	Associated Control Service Element
ANF	Additional Network Feature
ANF-ISI	all Additional Network Features of the Inter-System Interface
APDU	Application Protocol Data Unit
ASN.1	Abstract Syntax Notation One
BS	Base Station
C	conditional
CCK	Common Cipher Key
C-LDB	Controlling Linking DataBase
CMCE	Circuit Mode Control Entity
DCK	Derived Cipher Key
ECMA	European Computer Manufacturers Association
GFP	Generic Functional Protocol
GFT	Generic Functional Transport
GTSI	Group TETRA Subscriber Identity
GCK	Group Cipher Key
G-HDB	Group Home DataBase
G-VDB	Group Visited DataBase
HAC	Home Authentication Centre
HDB	Home DataBase
ISI	Inter-System Interface
ITSI	Individual TETRA Subscriber Identity

I-HDB	Individual Home DataBase
I-VDB	Individual Visited DataBase
K	authentication Key
LA	Location Area
LS	Line Station
M	mandatory
MCC	Mobile Country Code
MM	Mobility Management
MNC	Mobile Network Code
MNI	Mobile Network Identity
MRS	Mobile Radio Stack
MS	Mobile Station
NFE	Network Facility Extension
O	optional
OTAR	Over The Air Re-keying
PC	Protocol Control
PDU	Protocol Data Unit
PINX	Private Integrated Network eXchange
PISN	Private Integrated Services Network
P-LBD	Participating Linking DataBase
PSS1	Private Signalling System 1
ROSE	Remote Operation Service Element
RS	Random Seed
SAP	Service Access point
SCK	Static Cipher Key
SDL	Specification and Description Language
SD	Short Data
SSE	Segmentation Service Element
SSI	Short Subscriber Identity
SwMI	TETRA Switching and Management Infrastructure
TETRA	TErrestrial Trunked Radio
TSI	TETRA Subscriber Identity
VAC	Visitor Authentication Centre
(V)ASSI	Visiting Short Subscriber Alias Identity
V+D	Voice plus Data
VDB	Visitor DataBase
(V)GSSI	Visiting Short Subscriber Group Identity

4 ISI standardization methodology

4.1 3 stage methodology

The ISI Additional Network Features (ANFs) are standardized using the modelling method defined in CCITT Recommendation I.130 [1].

4.1.1 Stage 1

Stage 1 is a description of the services which the standardized ANF entity provides to the concerned service users, e.g. SwMI entities in the case of TETRA. The services are visible at the Service Access Points (SAPs). The stage 1 description is intended to allow an understanding of the services independently from the implementation.

For normal point to point services the service model is shown in figure 1.

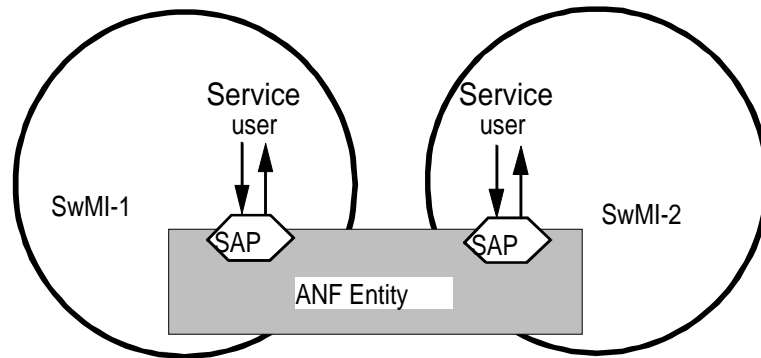

Figure 1: Service Model for Point to Point services

For point to multipoint services the service model is shown in figure 2.

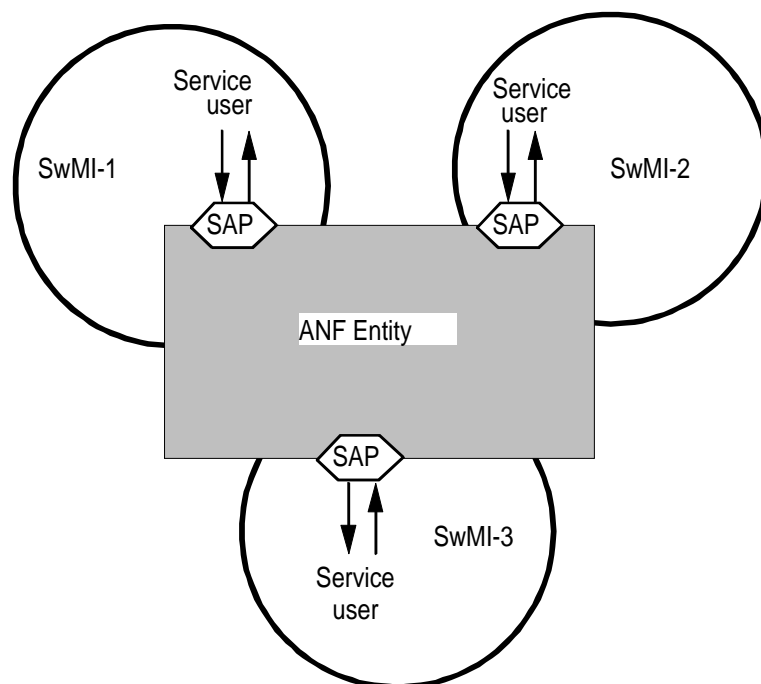

Figure 2: Service Model for Point to Multipoint services

4.1.2 Stage 2

Stage 2 identifies the functional capabilities and the information flows needed to support the service as described in stage 1.

4.1.3 Stage 3

Stage 3 gives a precise description of the signalling protocols for the ANF services, i.e. the encoding rules for the information flows and the corresponding procedures.

4.2 Usage of Specification and Description Language (SDL)

SDL defined in ITU-T Recommendation Z.100 [2] is used to identify and represent the behaviour of the concerned ANF in providing services.

5 Usage of Private Signalling System 1 (PSS1) for TETRA

5.1 PSS1 functionality

The TETRA ISI application is built on top of the PSS1 protocol stack for interconnecting Private Integrated Services network eXchanges (PINXs) to form Private Integrated Services Network (PISN). The PSS1 is the ISO term, which in ETSI, is also known as QSIG protocols developed by the European Computer Manufacturers Association (ECMA).

TETRA uses the standard functionalities defined for PSS1:

- signalling for the support of circuit-mode basic services (see note);
- generic functional protocol (GFP) originally defined for the support of supplementary services.

NOTE: The definition of PSS1 basic call in ISO/IEC 11572 [3] is as follows:

"The basic call is a single invocation of a basic service. Signalling procedures are used for establishing, maintaining and clearing a circuit-mode call at an interface between two PINXs. These signalling procedures are defined in terms of messages exchanged over a signalling carriage mechanism connection within the signalling channel of the Inter-PINX link. The result of successful basic call establishment is a connection for the purpose of user information transfer".

5.2 Protocol stack

Figure 3 shows how the protocols for TETRA ANF which apply at the ISI are built on top of the PSS1 protocol stack. The Remote Operation Service Element (ROSE) is used to convey ANF-ISI Protocol Data Units (PDU).

For the TETRA ANF-ISIIC and ANF-ISIGC protocols, figure 3 has to be supplemented with a direct interface to PSS1 protocol control for basic call. In addition, basic call correlation shall be ensured for the delivery of the corresponding PDUs by ANF-ISIIC and ANF-ISIGC through the protocol stack shown on figure 3.

NOTE: The PSS1 basic call protocol is defined in ISO/IEC 11572 [3].

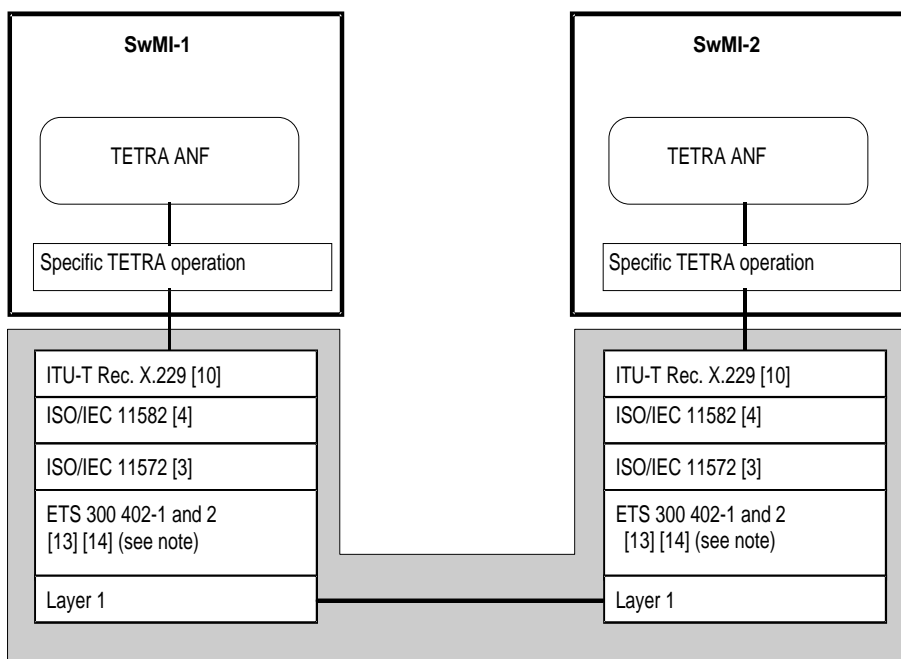

NOTE: Layer 2 protocol depends on the type of the inter-connection.

Figure 3: PSS1 protocol stack for TETRA

5.3 Generic Functional Protocol (GFP)

The GFP as defined in ISO/IEC 11582 [4] shall be used for all TETRA ANFs of the ISI (ANF-ISI).

ROSE operations shall be used to convey ANF-ISI information in facility information elements, as described in clause 8. These facility information elements shall be included in PSS1 messages in accordance with ISO/IEC 11582 [4]. The specification given in ISO/IEC 11582 [4], subclause 7.1.1.1, when a SwMI can send a PSS1 FACILITY message at the earliest, shall be understood as follows:

- such message can be sent by a receiving SwMI after it has sent a PSS1 CALL PROCEEDING message (following reception of a PSS1 SETUP message);
- such message can be sent by a source SwMI after it has received one of the following PSS1 messages: FACILITY, PROGRESS, ALERTING, CONNECT.

When the call independent signalling connection is used, it shall be connection oriented.

NOTE: This is in line with the choice made for the definition of all existing supplementary services of the PSS1 protocols.

6 TETRA SwMI roles using ISI

6.1 Management configurations

6.1.1 Migration and group attachment configurations

6.1.1.1 SwMI roles for migration and group attachment

In order to support the individual subscriber and group Mobility Management (MM) functionality in different SwMIs, the following roles are defined for SwMIs:

- **home SwMI:** The home SwMI performs the individual subscriber and group MM functions related to Home DataBase (HDB). The Mobile Network Identity (MNI) of the home SwMI shall be equal to that of the subscriber or of the group;
- **visited SwMI:** The visited SwMI performs the individual subscriber and group MM functions related to the Visitor DataBase (VDB). The MNI of the visited SwMI may or may not be equal to that of the subscriber or of the group;
- **previous visited SwMI:** The previous visited SwMI.

6.1.1.2 SwMI databases

In order to support the individual subscriber and group MM functionality in the SwMIs, the following database functionalities are defined for the SwMIs:

- the HDB comprises information about the individual and/or group subscribers. It is located in the subscriber's home SwMI. The HDB is divided into Individual HDB (I-HDB) and Group HDB (G-HDB):
 - I-HDB contains the location tracking amongst SwMIs, i.e. in which SwMI is an individual subscriber currently located. In addition, the I-HDB is able to provide the basic and optionally the supplementary service migration profiles of the individual subscriber at migration;
 - G-HDB contains the group attachment tracking amongst SwMIs, i.e. in which SwMI(s) subscribers are attached to the group. In addition, the G-HDB is able to generate the basic and optionally the supplementary service migration profiles of the group subscriber at group attachment;
- the VDB comprises temporary information about individual and/or group subscribers. It is located in the visited SwMI. The VDB is divided into Individual VDB (I-VDB) and Group VDB (G-VDB):

- I-VDB contains the Individual TETRA Subscriber Identity (ITSI) and Visiting Short Subscriber Alias Identity ((V)ASSI) association and the location tracking for the individual subscriber within the SwMI. In addition, the I-VDB is able to provide the basic and optionally the supplementary service migration profiles of the migrated individual subscriber;
- G-VDB contains the Group TETRA Subscriber Identity (GTSI) and Visiting Short Subscriber Group Identity ((V)GSSI) association and the group attachment tracking for the visited SwMI, i.e. which subscribers are attached to the group in the visited SwMI(s). In addition, the G-VDB is able to provide the basic and optionally the supplementary service migration profiles of the attached group;
- the Authentication Centre (AC) in the home SwMI, i.e. Home Authentication Centre (HAC), may provide the authentication and Over The Air Re-keying (OTAR) parameters for the migrated individual subscriber. Similarly, the AC in the visited SwMI, i.e. the Visitor Authentication Centre (VAC), may contain the authentication and OTAR parameters provided by the home SwMI MM for the migrated individual subscriber. The HAC and the VAC are used in conjunction with the security services as described in clause 10.

NOTE: For ISI mobility configuration, the ACs (HAC and VAC) are considered as databases.

6.1.1.3 Migration scenarios

The migration is the act of changing to a new Location Area (LA) in a network (either with different Mobile Network Code (MNC) and/or Mobile Country Code (MCC)) where the subscriber is not registered, i.e. does not have an I-VDB record.

The migration shall take place either:

- when an individual subscriber roams from one SwMI to another, i.e. from the previous visited SwMI to the visited SwMI; or
- at power on, when the individual subscriber requests registration (migration) in a visited SwMI of which the MNI is different from that of the subscriber.

At migration, the home SwMI may or may not coincide with either the visited SwMI or with the previous visited SwMI.

NOTE: In this ETS, the term "coincide" means "to have the same MNI".

Figure 4 illustrates the ISI configuration when a subscriber migrates from the previous visited SwMI to the visited SwMI, and when the home SwMI does not coincide with either the previous visited SwMI or the visited SwMI.

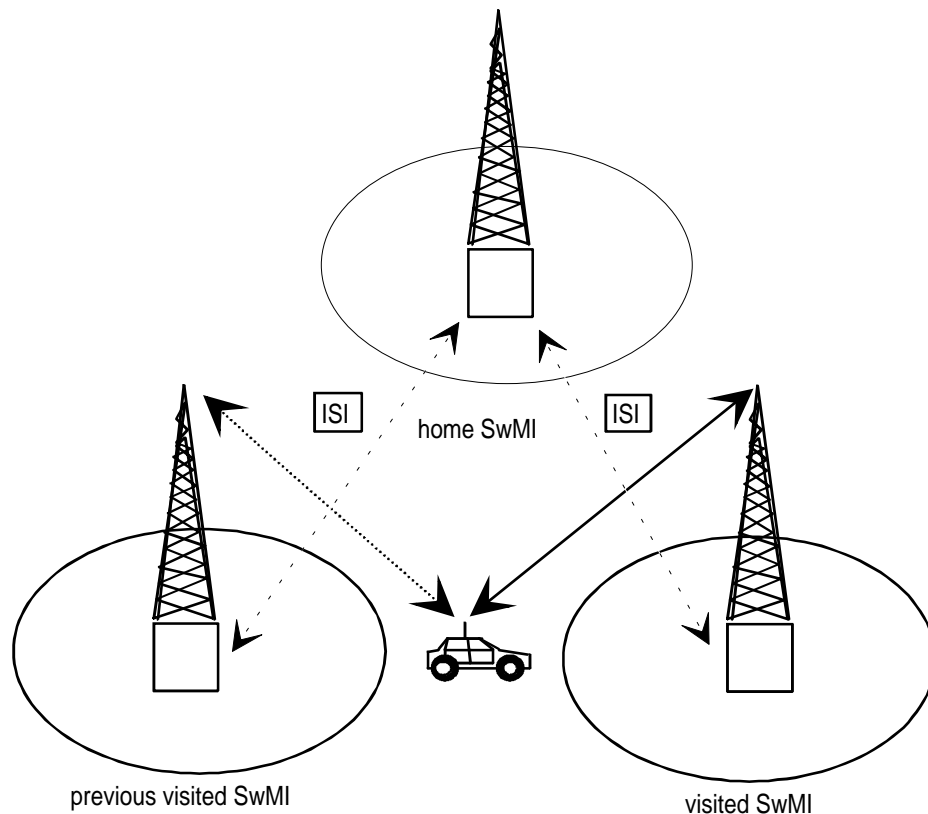

Figure 4: Migration scenario between SwMIs

At migration, the home SwMI shall update the subscriber's location information in the I-HDB to be used for the subscriber's location tracking amongst the SwMIs.

The visited SwMI shall create an I-VDB record to be used for the subscriber's location tracking within the visited SwMI. In addition, the visited SwMI shall create the subscriber's migration profiles and save them in the I-VDB. The migration profiles shall indicate the subscriber's service authorizations during the migration in the visited SwMI. The visited SwMI shall also allocate the (V)ASSI for the individual subscriber as defined in ETS 300 392-1 [5], subclause 7.2.2.

If the subscriber was registered prior to the migration, the previous visited SwMI shall remove the subscriber's information that has been created and save in the previous visited SwMI. This information is e.g. the I-VDB record and the ITSI-(V)ASSI association.

A MS/LS may contain more than one TETRA Subscriber Identity (TSI) family and each of those shall migrate independently.

6.1.1.4 Group attachment scenarios

The group attachment enables migrated subscribers to participate in group calls if the home SwMI of the group and that of the migrated subscriber coincide. As result of the group attachment, the home SwMI shall know to which SwMIs the group call shall be extended and the visited SwMI shall know to which subscribers the group call shall be set-up.

Figure 5 illustrates the ISI configuration for the group attachment, which shall take place between the home SwMI (of the group and of the subscriber) and the visited SwMI in which the subscriber is migrated.

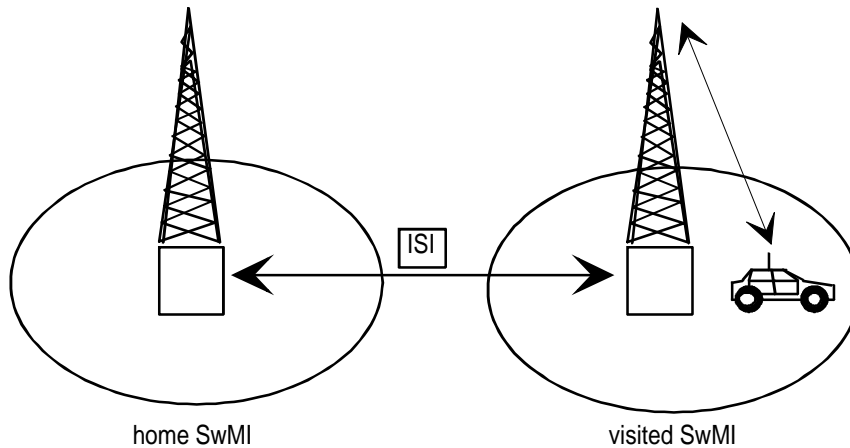

Figure 5: Group attachment scenario

When the group is attached for the first time in the visited SwMI, the home SwMI shall update the group attachment to the G-HDB to be used for the group attachment tracking amongst the SwMIs.

The visited SwMI shall create a G-VDB record to be used for the subscribers' group attachment tracking within the visited SwMI. In addition, the visited SwMI shall create the migration profiles for the group and save them in the G-VDB. The migration profiles shall indicate the service authorizations for the group in the visited SwMI. The visited SwMI shall also allocate the (V)GSSI for the group as defined in ETS 300 392-1 [5], subclause 7.2.2.

A subscriber may attach to one or more groups and each of those shall be attached independently.

6.1.2 Group linking configurations

The group linking shall enable the dynamic linking, i.e. combining, of groups having different SwMIs as their home SwMIs over the ISI. After the group linking the group calls made to any of the groups shall result in combined group calls consisting of all the members of the linked groups. The combined group call is described in the ETS defining ANF-ISIGC.

In order to support the group linking functionality in different SwMIs, the following roles are defined for SwMIs:

- linking controlling SwMI: The group linking controlling SwMI controls the making of the linking for the group, i.e. group linking. In addition, the linking controlling SwMI creates the group linking service profile to be used for the group linking. The group linking controlling SwMI is the home SwMI of one of the linked groups;
- linking participating SwMI: The group linking participating SwMI participates the group linking in linking (joining) one group to the group linking. The group linking participating SwMI is the home SwMI of the linked group;
- linking originating SwMI: The group linking originating SwMI originates the request to group linking. The group linking originating SwMI is either the group linking controlling SwMI or the group linking participating SwMI.

In addition, the following database functionalities are defined for the SwMIs supporting group linking:

- Controlling Linking DataBase (C-LDB): The C-LDB contains the linking tracking for the linked groups, i.e. the information which groups are part of the group linking. In addition, the C-LDB contains the linking service profile for the group linking;
- Participating Linking DataBase (P-LDB): The P-LDB contains the linking tracking for one of the linked groups, i.e. the information whether the group is linked or not. The P-LDB is located in the home SwMI of the group.

From two to several groups may be linked together using group linking. Figure 6 illustrates the ISI configuration for group linking when three groups are linked together.

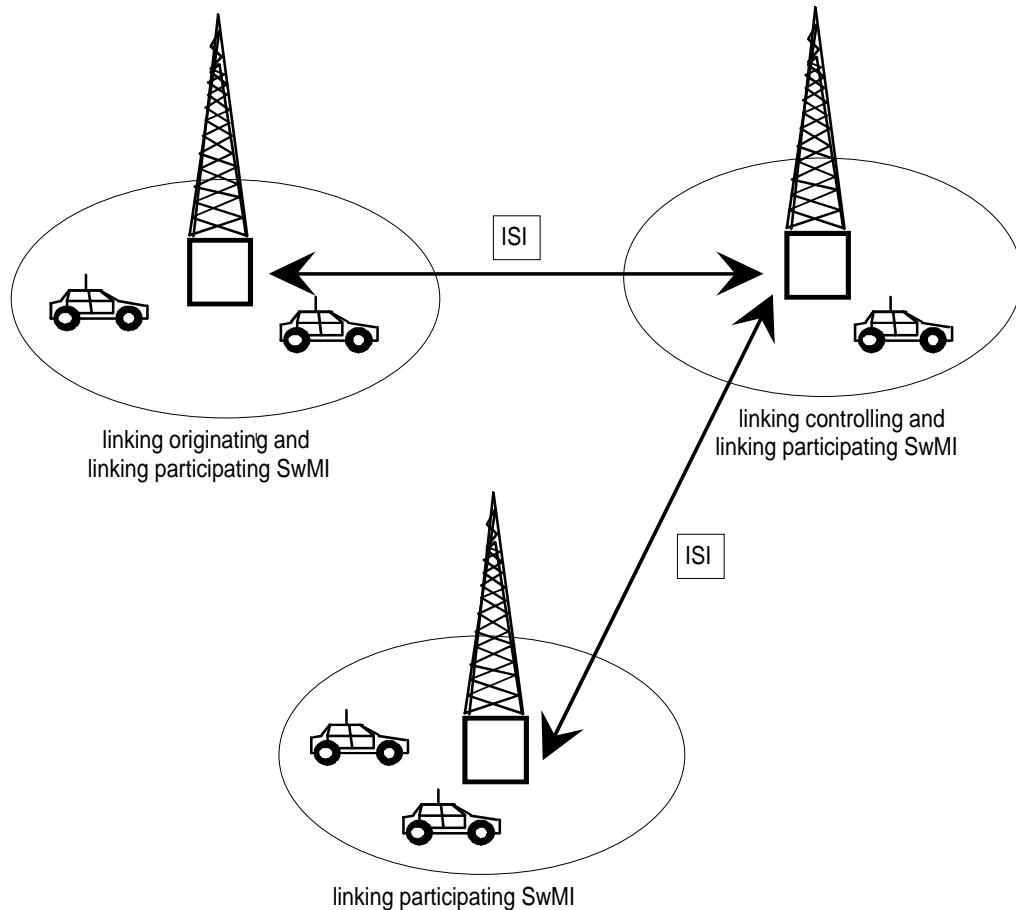

Figure 6: Group linking scenario

At group linking, the linking controlling SwMI shall co-ordinate and keep track of the group linking amongst the linking participating SwMIs. In addition, the linking controlling SwMI shall create the linking service profile for the group linking and save it to the C-LDB.

Each of the linking participating SwMIs shall link a group to the group linking and create a P-LDB record to be used for the group during the group linking.

A group can be part of only one group linking at a given time.

6.2 Call configurations

Whether it is a group call or an individual call, a call is originated by a calling user. The SwMI where this user is located is called the originating SwMI. By definition, the originating SwMI is the visited SwMI of the calling user. It may or may not be its home SwMI.

The other possible roles for SwMIs in a group call and in an individual call where an ISI is involved are presented in the following.

6.2.1 Group call configuration

In order to support group call processing in different SwMIs, the following roles are defined, in addition to that of originating SwMI:

- controlling SwMI: The controlling SwMI shall be in charge to set up and maintain a call extending over two or more SwMIs or to deliver a short data service request involving more than one SwMI. The controlling SwMI shall be the group home SwMI;
- participating SwMI: The participating SwMI only participates in the call without controlling it. The participating SwMI shall always be the end point of the call, i.e. where the call is terminated.

NOTE: Once the originating SwMI has requested the establishment of the call over the ISI to the controlling SwMI, it does not make anymore actions.

Point-to-multipoint call set-up between SwMIs shall be set-up as a logical star configuration where the controlling SwMI shall be the centre of the star.

When a user sets up a group call, the controlling SwMI shall establish the call. This shall hold regardless of whether the calling user is located or not in its home SwMI and regardless of whether the calling user is a member of the group or not. Some called users may be located in the controlling SwMI.

Figure 7 illustrates the ISI configuration when a group call is initiated between two SwMIs, the originating SwMI being the home SwMI of the group. The originating SwMI is then also the controlling SwMI.

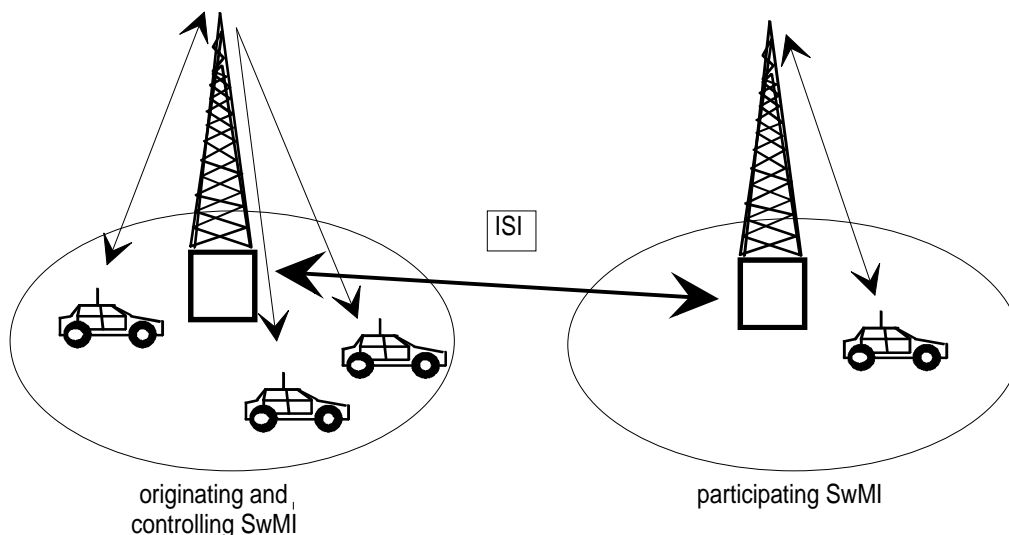

Figure 7: Group call configuration

Figure 8 illustrates the ISI configuration when the originating SwMI of a group call is not the group home SwMI. The originating SwMI becomes then a participating SwMI.

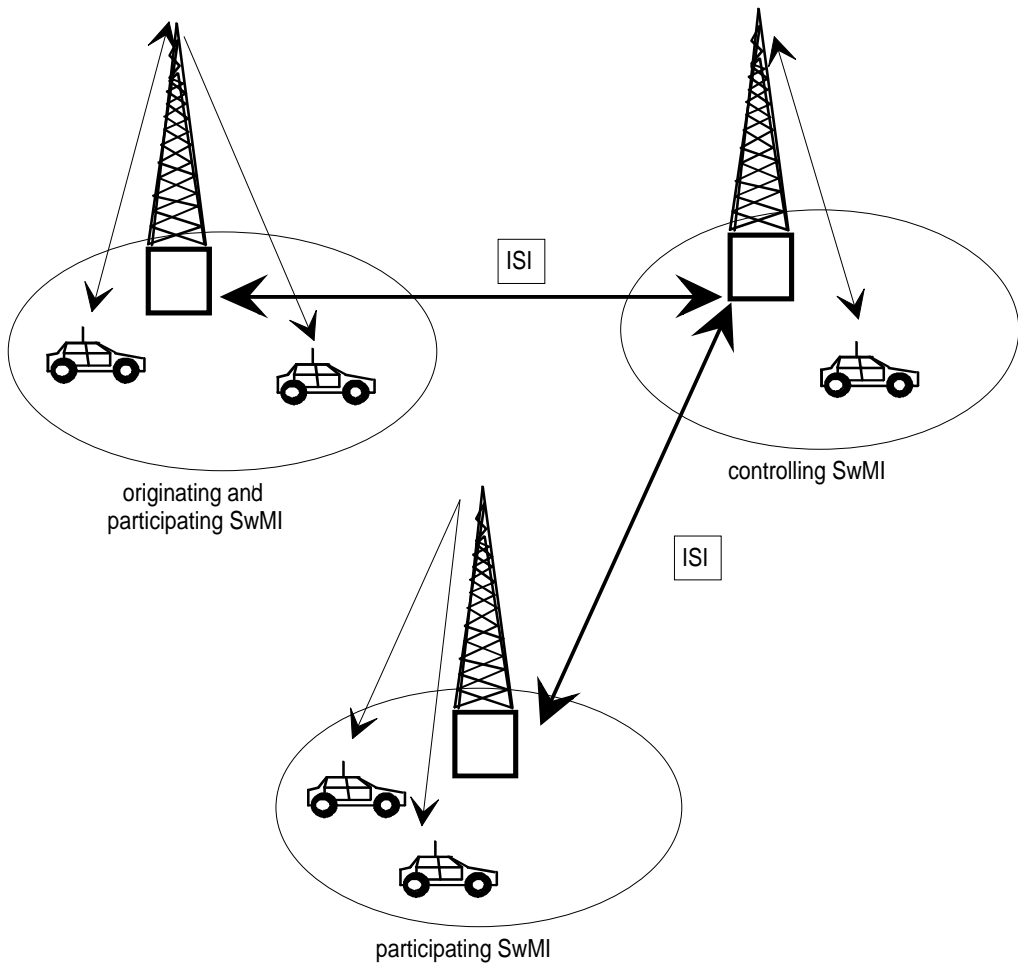

Figure 8: Group call configuration

6.2.2 Individual call configuration

When a SwMI sets up an individual call an ANF-ISIIC shall be invoked to extend this call over the ISI. Figure 9 illustrates the ISI configuration when an individual call is initiated between two SwMIs.

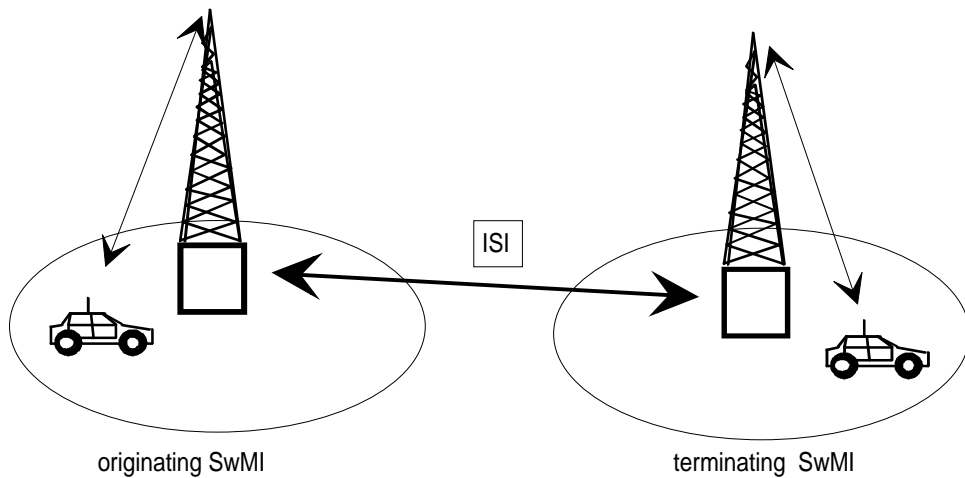

Figure 9: Individual call configuration

When a user is called, the invoked ANF-ISIIC will first route the call request in the called SwMI, this routing being independent of whether or not the originating SwMI is the home SwMI of the calling user. The invoked ANF-ISIIC will then ensure the adequate routing of the call to the terminating SwMI in the called SwMI. Three possible cases arise for this routing:

- the called SwMI is the called user home SwMI and this user has not migrated; or
- the called SwMI is the called user home SwMI and this user has migrated; or
- the called SwMI is not the called user home SwMI and this user has migrated (i.e. its home SwMI is the originating SwMI).

By definition, the originating SwMI shall be the controlling SwMI for half duplex operation.

6.2.3 Transit

Additionally any SwMI shall have a transit capability for the following cases:

- forward switching in the case of individual call where the SwMI is the called user home SwMI and where the called user has migrated;
- call restoration;
- specific supplementary operation (e.g. call diversion).

NOTE: In addition, a SwMI may act as a standard PISN transit, but this is outside the scope of this ETS.

6.2.4 User information encoding at the ISI

Whether in a group call or in an individual call, the user information will be sent over ISI user information connections, which will be considered as B_Q channels by the PSS1 protocols used to establish these calls.

It has been assumed that these connections will be digital, their standard data rate being 64 kbit/s.

The user information sent in one air interface slot shall be encoded at the ISI into an 8 kbit/s bit stream. This encoding is defined in other parts of this ETS for both data calls (at 7,2 kbit/s, 4,8 kbit/s or 2,4 kbit/s) or speech calls. It allows to carry stolen frame signalling in-band and to identify precisely such signalling within the user information bit stream.

As a result, calls which use N slots at the air interface, with $N = 2$ to 4, shall be multiplexed into $N \times 8$ kbit/s streams, which would still be carried by the same 64 kbit/s B_Q channel (the corresponding straightforward multiplexing being defined in CCITT Recommendation I. 460 [6]).

As an option 8 kbit/s connections could be considered for B_Q channels, N slot calls being handled over the ISI as PSS1 multi-rate calls, when this option will have been standardized for 8 kbit/s channels.

7 Introduction to ISI ANFs

The following ANFs will be defined for the ISI:

- Additional Network Feature - Inter-System Interface Mobility Management (ANF-ISIMM);
- Additional Network Feature - Inter-System Interface Individual Call (ANF-ISIIC);
- Additional Network Feature - Inter-System Interface Group Call (ANF-ISIGC);
- Additional Network Feature - Inter-System Interface Short Data Service (ANF-ISISDS);
- Additional Network Feature - general requirements for Supplementary Services (SS) - see clause 10 of ETS 300 392-9 [15].

All their protocols will be designed so that their messages can be routed through transit PISNs, together with the associated call for those messages which are call related.

7.1 ANF-ISIMM

ANF-ISIMM enables the TETRA air interface MM, authentication and OTAR services between SwMIs sharing an ISI. In doing so, ANF-ISIMM allow the subscribers e.g. to migrate, to be authenticated, to attach to groups and, thus, to participate in individual and group calls.

NOTE: The TETRA air interface MM services are defined in ETS 300 392-2 [7], clause 15, and the TETRA security authentication and the OTAR key management services in ETS 300 392-7 [8], clause 4. However, ANF-ISIMM does not support the forward registration nor the assignment of Group Cipher key (GCK) as defined in ETS 300 392-2 [7], clause 15, and in ETS 300 392-7 [8], clause 4, respectively.

In addition, ANF-ISIMM offers database fault recovery services for SwMIs, in order to recover the databases after faulty situations, and group linking and unlinking services, in order to enable the dynamic combining of groups to support combined group calls between SwMIs.

7.2 ANF-ISIIC

ANF-ISIIC enables calls to be set-up from a TETRA user registered in one SwMI to another TETRA user registered in another SwMI, operating at the ISI of both SwMIs. It also supports call restoration when a user has migrated to another TETRA SwMI during an established call. Additionally, ANF-ISIIC allows TETRA signalling information to be passed from a TETRA SwMI to another TETRA SwMI supporting the TETRA Individual Call procedures as defined in clauses 11 and 14 of ETS 300 392-2 [7].

7.3 ANF-ISIGC

ANF-ISIGC enables point-to-multipoint calls to be set-up between TETRA users located in more than one TETRA SwMI, operating at the ISI of all these SwMIs. It also supports call restoration when a user has migrated to another TETRA SwMI during an established call. Additionally, the ANF-ISIGC shall handle transmission control signalling from all SwMIs involved in the given group call supporting the point to multipoint TETRA call procedures defined in clauses 11 and 14 of ETS 300-392-2 [7].

7.4 ANF-ISISDS

ANF-ISISDS enables point-to-point or point-to-multipoint short data messages to be passed between TETRA users located in more than one TETRA SwMI, operating at the ISI of all these SwMIs.

7.5 ANF-ISISS

ANF-ISISS is a transport mechanism to allow signalling information exchange between two SwMI Circuit Mode Control Entities (CMCEs), as defined in ETS 300 392-2 [7], clause 14, for the control of TETRA supplementary services. It operates at the ISI of both SwMIs.

It is used for the exchange of signalling information between peer CMCEs in the specifications of supplementary service protocols.

8 ISI Generic Functional Protocol (ISI GFP)

8.1 Protocol model

The TETRA ISI is based on the PSS1 protocols stack in order to enable the interconnection of SwMIs via transit PISNs. Signalling needs for TETRA ISI operation which are not directly supported by PSS1 protocols are provided by ISI GFP.

ISI GFP does not by itself control any ANF-ISI PDUs but rather provides a means to convey them.

Figure 10 shows the conceptual model of the ISI GFP and its relationship to the various ANF entities. It is derived from figure 3 of ISO/IEC 11582 [4].

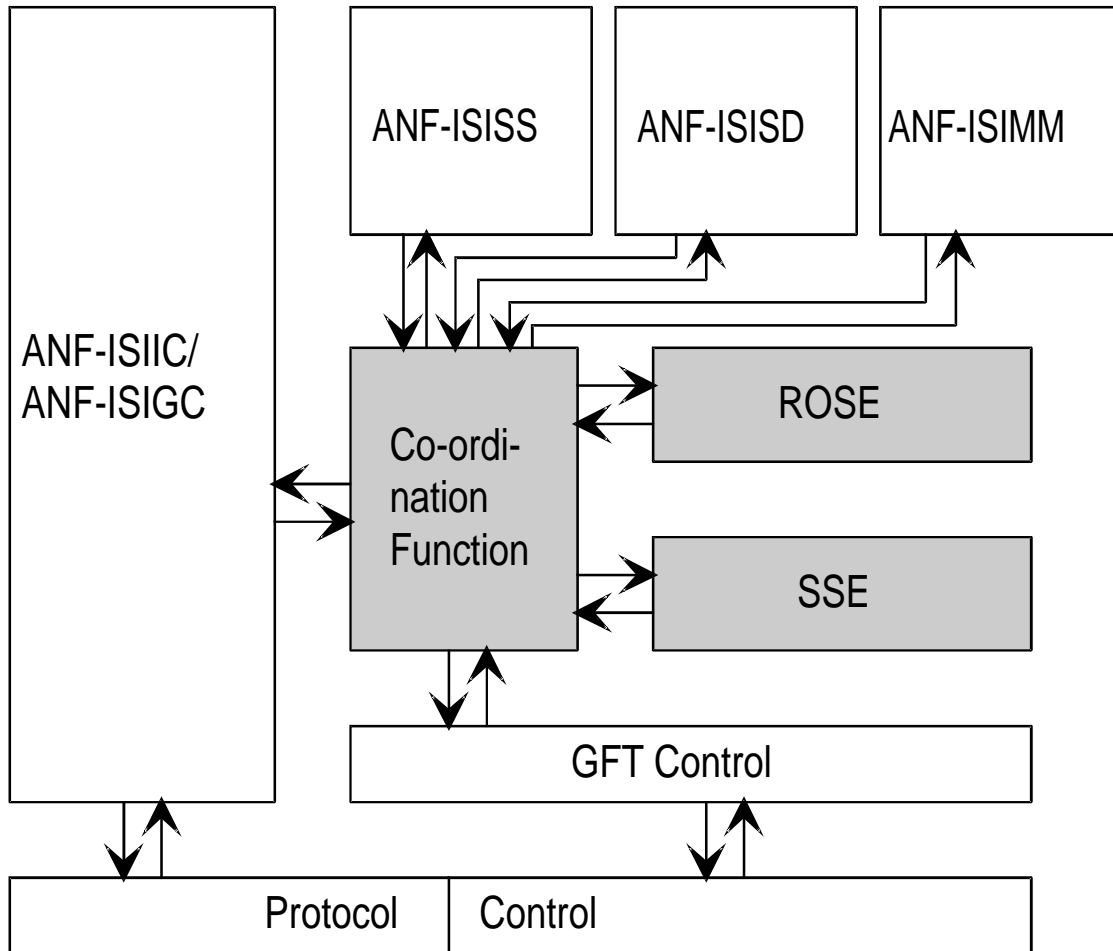

ROSE = Remote Operations Service Element;
 SSE = Segmentation Service Element;
 GFT = Generic Functional Transport.

NOTE: Capabilities defined in this ETS are indicated by shading, i.e. ROSE, SSE and Co-ordination function.

Figure 10: Protocol model of the ISI Generic Functional Protocol

The entities Protocol Control (PC), Generic Functional Transport (GFT) control, co-ordination function and ROSE shall exist in any SwMI which supports the ISI. The existence in a SwMI of the other entities shown on figure 10 shall depend on the ANF-ISI supported by this SwMI.

8.2 Services provided by the protocol model entities

ANF entities (i.e. ANF-ISIIC, ANF-ISIGC, ANF-ISISD, ANF-ISISS and ANF-ISIMM entities) use the services of the ROSE entity via the co-ordination function in order to convey ANF-ISI PDUs through a PISN.

The corresponding ROSE primitives shall be those specified in CCITT Recommendation X.219 [9].

If a ROSE Application Protocol Data Unit (APDU) length exceeds its possible maximum length, as defined in subclause 8.5, the co-ordination function shall address it to the Segmentation Service Element (SSE) so that this ROSE APDU can be transparently transported in spite of its length.

ROSE and SSE entities shall use the connection oriented services of PSS1 GFT control, which in turn uses the PC services, as defined in subclauses 6.7.1 and 6.8 of ISO/IEC 11582 [4] respectively. The corresponding PISN protocols are defined in subclauses 7.1 and 7.3 of ISO/IEC 11582 [4]. The interaction between ROSE users, the ROSE entity itself, SSE and GFT control is co-ordinated by the co-ordination function.

ANF-ISIIC and ANF-ISIGC use PC services for sending the PSS1 basic call messages as defined in ISO/IEC 11572 [3]. They also use the extensions of PC services and the call related services of GFT control together with the services of ROSE and of the co-ordination function to achieve the sending of specific PDUs, as defined in ISO/IEC 11582 [4]. Those specific PDUs carry either:

- complementary TETRA call information, in PSS1 basic call messages; or
- TETRA call related messages, in PSS1 FACILITY messages.

ANF-ISIMM uses the call independent connection oriented services of GFT control and the related extensions of PC services, both as defined in ISO/IEC 11582 [4].

NOTE 1: ANF-ISIMM PDUs are TETRA call unrelated PDUs sent in PSS1 messages.

ANF-ISISD and ANF-ISISS use the same services as ANF-ISIMM for their call unrelated procedures. They use the call related connection oriented services of GFT control and the related extensions of PC services, both as defined in ISO/IEC 11582 [4] for their call related procedures.

NOTE 2: The latter statement implies that ANF-ISISD and ANF-ISISS use the signalling connections of either ANF-ISIIC or ANF-ISIGC for their call related procedures.

8.3 Addressing and routing

8.3.1 Addressing

Unless they are addressed implicitly (e.g. end PINX), all PSS1 messages shall be addressed using PISN numbers, so that they can be routed through a PISN.

Such PISN numbers shall be defined as follows for the message concerning a given TETRA subscriber:

- for a message addressed to the home SwMI of the subscriber, the PISN number shall be defined by a routing table. Such table in a given SwMI shall have MNI entries which give the PISN number to be used for addressing messages to a SwMI;
- for a message addressed to the visited SwMI when it is different from the home SwMI, the PISN number shall be that indicated by this SwMI to the home SwMI. More precisely, this PISN number will have been sent by ANF-ISIMM from the visited SwMI MM entity to the home SwMI MM entity.

This implies that to send a message to the visited SwMI when it is different from the home SwMI, any other SwMI than the home SwMI shall have first to get the corresponding PISN number from this home SwMI;

NOTE 1: When the visited SwMI is different from the home SwMI, in most cases it will not be addressed using such PISN number, but implicitly as end PINX of signalling connection.

- for a message addressed to any other SwMI, the corresponding PISN number shall then be either:
 - explicitly given; or
 - determined on the basis of the SwMI MNI;
 given in some previous message.

NOTE 2: In other words, the definitions of the various ANF-ISI protocols have to cater for the indication of the destination SwMI PISN number to every source SwMI. The same applies also for the definitions of the supplementary service protocols which use ANF-ISISS.

The PISN numbers defined above shall always correspond to SwMIs or SwMI entities, and never to any TETRA subscriber. Unless addressed implicitly (e.g. during a call), a TETRA individual subscriber shall be addressed using its ITSI and a TETRA group using its GTSI. This ITSI or GTSI shall be included in the ANF-ISI PDUs carried by the ISI GFP.

8.3.2 Routing of ROSE APDUs

As required by subclause 7.1.2.1 of ISO/IEC 11582 [4], the ROSE APDUs shall be included in PSS1 facility information elements.

NOTE: The corresponding APDU encoding is defined in subclause 11.3.3 of ISO/IEC 11582 [4].

8.3.2.1 Call related ROSE APDUs

All call related ROSE APDUs shall be routed using the signalling connection established for the corresponding call, by ANF-ISIIC, if the call is an individual call, or by ANF-ISIGC, if the call is a group call.

8.3.2.2 Call unrelated ROSE APDUs

All call unrelated ROSE APDUs shall be routed using a call independent signalling connection.

8.3.2.2.1 Establishment of a call independent signalling connection

The procedure to establish a call independent signalling connection shall be that defined in subclause 7.3 of ISO/IEC 11582 [4], supplemented by a specific one in the case where the ROSE APDU destination is either a MS having migrated or its visited SwMI. This procedure shall be as follows, where according to subclause 8.4, all the ANF-ISI PDUs defined below are conveyed as ROSE APDUs:

- the PSS1 SETUP message addressed to the MS home SwMI shall include the ANF-ISI PDU defined in table 1;

Table 1: Contents of ANF-ISI PDU in the PSS1 SETUP message sent by the originating SwMI

Information element	Length	Type	C/O/M	Remark
PDU type	6	1	M	see note
Originating SwMI MNI	24	1	M	
Routing method choice	2	1	M	
NOTE: This value shall be equal to 000111 ₂ .				

- with the information element routing method choice being coded as defined in table 2;

Table 2: Routing method choice information element contents

Information element	Length	Value	Remark
Routing method choice	2	00 ₂	Re-routeing not supported
		01 ₂	Re-routeing supported, forward switching preferred
		10 ₂	Re-routeing supported, the called SwMI may choose between forward switching and re-routeing
		11 ₂	Re-routeing supported, possible choice between forward switching and re-routeing to be made by originating SwMI

- depending on the contents of the information element routing method choice in the preceding PSS1 SETUP message, the MS home SwMI shall:
 - either extend this SETUP message to the MS visited SwMI in sending a PSS1 SETUP message which shall include the ANF-ISI PDU defined in table 3;

Table 3: Contents of TETRA PDU in PSS1 SETUP message

Information element	Length	Type	C/O/M	Remark
PDU type	6	1	M	see note
Originating SwMI MNI	24	1	M	
NOTE: This value shall be equal to 100111 ₂ .				

- or send to the originating SwMI:
 - a PSS1 DISCONNECT message which shall include either the ANF-ISI PDU defined in table 4, if the MS happens to be registered in the originating SwMI, or the ANF-ISI PDU defined in table 5, if the originating SwMI had otherwise imposed that the signalling connection be established by re-routing;

Table 4: Contents of ANF-ISI PDU sent by the MS home SwMI in the PSS1 DISCONNECT message to avoid a trombone or a loop signalling connection

Information element	Length	Type	C/O/M	Remark
PDU type	6	1	M	see note 1
Disconnect cause	6	1	M	see note 2
NOTE 1: This value shall be equal to 100110 ₂ .				
NOTE 2: This value shall be equal to 100101 ₂ ("ANF clearing to avoid a trombone or a loop connection").				

Table 5: Contents of ANF-ISI PDU sent by the MS home SwMI in a PSS1 DISCONNECT message to clear the signalling connection with this SwMI when re-routing of this connection has been imposed

Information element	Length	Type	C/O/M	Remark
PDU type	6	1	M	see note 1
Disconnect cause	6	1	M	see note 2
NOTE 1: This value shall be equal to 110110 ₂ .				
NOTE 2: This value shall be equal to 101110 ₂ ("call re-routed").				

- or a PSS1 FACILITY which shall include the ANF-ISI PDU defined in table 6 informing the originating SwMI about the MS migration.

Table 6: Contents of ANF-ISI PDU sent by the MS home SwMI in a PSS1 FACILITY message in case of migration of the MS

Information element	Length	Type	C/O/M	Remark
PDU type	6	1	M	see note 1
Visited SwMI PISN number length	5	1	M	see note 2
Visited SwMI PISN number digits	variable	1	C	see note 3
NOTE 1: This value shall be equal to 111110 ₂ .				
NOTE 2: Shall be equal to N, N being the number of digits of the visited SwMI PISN number.				
NOTE 3: The number of digits included in this information element shall be equal N, the value of the visited SwMI PISN number length (see note 2).				

The originating SwMI shall then send:

- either a PSS1 FACILITY message which shall include the ANF-ISI PDU defined in table 7, to request that the signalling connection be established by forward switching;

Table 7: Contents of ANF-ISI PDU sent by the originating SwMI in a PSS1 FACILITY message in case of migration of the MS

Information element	Length	Type	C/O/M	Remark
PDU type	6	1	M	see note
NOTE: This value shall be equal to 111111 ₂ .				

- or a PSS1 DISCONNECT message which shall include the ANF-ISI PDU defined in table 8, if the originating SwMI has decided to establish the signalling connection by re-routeing;

Table 8: Contents of ANF-ISI PDU sent by the originating SwMI in a PSS1 DISCONNECT message to clear the signalling connection with the home SwMI when it decides to re-route this connection

Information element	Length	Type	Owner	C/O/M	Remark
PDU type	6	1	CC	M	see note 1
Disconnect cause	6	1	CC	M	see note 2
Facility		3	SS	O	
Proprietary		3	-	O	
NOTE 1: This value shall be equal to 110110 ₂ .					
NOTE 2: This value shall be equal to 101110 ₂ ("call re-routed").					

- the PSS1 CONNECT message sent by the MS visited SwMI shall include the ANF-ISI PDU defined in table 9.

Table 9: Contents of ANF-ISI PDU PDU sent in the PSS1 CONNECT message

Information element	Length	Type	C/O/M	Remark
PDU type	6	1	M	see note
Terminating SwMI MNI	24	1	M	
NOTE: This value shall be equal to 000010 ₂ .				

8.3.2.2.2 Use of a call independent signalling connection already established

A SwMI may use a call independent signalling connection already established, notably to respond to a request PDU received from a MS. For how long this SwMI may use it is an implementation issue.

In the case where this SwMI uses such connection for sending a TETRA PDU, according to the definition in subclause 8.4 of the ROSE operation used to carry the TETRA PDU, this SwMI will be informed when either this MS is not anymore registered in the destination SwMI or it cannot be reached. In such a case, this SwMI might then use the procedure defined in subclause 8.3.2.2.1 to establish a new call independent signalling connection, and resend the TETRA PDU.

NOTE: According to subclause 7.3.1 of ISO/IEC 11582 [4] and as illustrated on its figure 28, this TETRA PDU may be included in the PSS1 SETUP message used to establish the new signalling connection.

8.4 Remote Operations Service Entity (ROSE) requirements and operation definition

8.4.1 General

The protocol defined in CCITT Recommendation X.229 [10] shall apply for each ROSE SwMI entity, with the exception of:

- clause 8 of this recommendation, since the Transfer services used shall be those provided by GFT-Control; and
- the value of the InvokeldType shall lie in the range (-32 768 .. 32 767), instead of being unlimited, i.e. the ASN.1 type InvokeldType defined as INTEGER in figure 1 of CCITT Recommendation X.229 [10] shall be changed into INTEGER (-32 768 .. 32 767).

NOTE 1: The two above provisions are derived from subclause 8.2 and table 34 of ISO/IEC 11582 [4], respectively.

Each ANF-ISI PDU shall be encoded as an OCTET STRING in the argument of the ROSE operation tetralsiMessage specified in table 10 using Abstract Syntax Notation One (ASN.1).

NOTE 2: This ROSE operation is common to all ANF-ISI protocols.

Table 10: ROSE operation in support of TETRA encoding PDU

<pre> TetralsiOperation {ccitt (0) identified-organization (4) etsi (0) tetra(392) isi-encoding- operation(0)} DEFINITIONS EXPLICIT TAGS ::= BEGIN IMPORTS OPERATION, ERROR FROM Remote-Operations-Notation {joint-iso-ccitt (2) remote-operations (4) notation (0) }; TetralsiMessage OPERATION -- TETRA ANF-ISI message encoded in the argument ARGUMENT IsiArgument RESULT IsiResult ERRORS { incompleteTetraPDU, requestNotSupported, invalidInfoElement, unspecified} -- Definition of general used data types: IsiArgument ::= SEQUENCE { sourceEntity [0] IMPLICIT AnfSubEntity, destinationEntity [1] IMPLICIT AnfSubEntity, tetraMessage [2] IMPLICIT OCTET STRING, } IsiResult CHOICE { NULL IsiArgument } </pre>

```
incompleteTetraPdu  ERROR
                    PARAMETER ErrorOctetString
                    ::=1
itsiNotRegistered ERROR
                    ::=2
itsiNotReachable ERROR
                    ::=3
requestNotSupported ERROR
                    PARAMETER ErrorRequestNotSupported
                    ::=4
invalidInfoElement  ERROR
                    PARAMETER ErrorInvalidInfo
                    ::=5
unspecified         ERROR
                    ::= 0

AnfSubEntity        ::= ENUMERATED {anflsiss (1), anflsimm (2), anflsiic (3), anflsigc (4),
anflsisd (5)}

ErrorOctetString
    SEQUENCE{
        octetstring [0] IMPLICIT OCTETSTRING,
    }

ErrorRequestNotSupported
    CHOICE {
        mmRequestNotSupprted      MMRequestNotSupported,
        ssRequestNotSupprted      SSRequestNotSupported
    }

MMRequestNotSupported [0] IMPLICIT OCTET STRING
SSRequestNotSupported
    CHOICE {
        [1] IMPLICIT ListSSNotSupported,
        [2] IMPLICIT ListSSActionNotSupported
        [3] IMPLICIT CombinedSSLListNotSupported
    }

ListSSNotSupported  OCTET STRING OPTIONAL,
ListSSActionNotSupported
    CHOICE {
        [4] IMPLICIT SSACTIONNotSupported,
        [5] IMPLICIT SEQUENCE OF SSACTIONNotSupported
    }

SSActionNotSupported
    SEQUENCE {
```

```
        ssType          [6] IMPLICIT OCTET STRING,
        ssPduType       [7] IMPLICIT OCTET STRING
    }
CombinedSSLListNotSupported
    SEQUENCE{
        listSSNotSupported      ListSSNotSupported,
        listSSActionNotSupported ListSSActionNotSupported
    }
ErrorInvalidInfo
    CHOICE {
        [0] IMPLICIT InvalidInfoType
        [1] IMPLICIT SEQUENCE OF InvalidInfoType,
    }
InvalidInfoType
    SEQUENCE {
        PDUIndicator      [2] IMPLICIT OCTET STRING
        elementType       [3] IMPLICIT INTEGER (1..3),
        elementPosition   [4] IMPLICIT INTEGER,
    }

tetralsiMessage      TetralsiMessage ::= 1

END -- OF TetralsiOperation
```

ROSE APDUs shall be encoded in accordance with the Basic Encoding Rules (BER) defined for ASN.1 in CCITT Recommendation X.209 [11], with the same restrictions as defined in subclause 11.4 of ISO/IEC 11582 [4].

The following data elements shall be included in the argument of the tetralsiMessage Invoke APDU:

- element destinationEntity, which defines the destination ANF in the receiving ISI;
- element sourceEntity, which defines the source ANF of the Invoke APDU;
- element tetraMessage, which contains the ANF-ISI PDU.

8.4.2 Return-result

The tetralsiMessage ReturnResult APDU enables the receiving SwMI to return a positive reply to an Invoke APDU. It shall be used when an ANF-ISI PDU sent in the Invoke APDU needs a ROSE confirmed response. The argument of the tetralsiMessage ReturnResult APDU shall include the same data elements as for the Invoke APDU.

8.4.3 Return-error

The tetraIcsiMessage ReturnError APDU enables the receiving SwMI to return a negative reply, if a tetraIcsiMessage Invoke APDU while still being recognized as at least partially valid cannot be accepted because of one or more of the following errors:

- incompleteTetraPdu: the received ANF-ISI PDU was incomplete because of segmentation error (see subclause 8.5);
 - itsiNotRegistered: the ANF-ISI PDU is addressed to an MS not registered in the receiving SwMI;
 - itsiNotReachable: the ANF-ISI PDU is addressed to an MS which the receiving SwMI is unable to reach;
 - requestNotSupported: the destination entity does not support the service requested by the ANF-ISI PDU. This error shall only be used by ANF-ISIMM and ANF-ISISS. Its use is specified in the protocol definition of these ANFs (e.g. see subclause 10.3 of ETS 300 392-9 [15] for ANF-ISISS). The parameter of this error is dependent on the destination entity:
 - if the destination entity is the ANF-ISIMM, the parameter shall contain the value (or the list of values) of the information element ANF-ISIMM PDU type corresponding to the ANF-ISIMM PDU(s) not supported;
 - if the destination entity is the ANF-ISISS, the parameter shall contain one or both of the two following lists:
 - for the request(s) related to SS(s) not supported, the corresponding value (or the corresponding list of values) of the information element SS type (see table 5 of ETS 300 392-9 [15]);
 - for the request(s) related to action(s) not supported for specific SS(s) (which is(are) supported), the corresponding values (or the corresponding list of values) of the information elements SS type and SS PDU type (see tables 5 and 6 of ETS 300 392-9 [15]).
 - invalidInfoElement: at least one element of the ANF-ISI PDU cannot be understood. For each such PDU the first invalid information element detected shall be indicated by the parameter of this error using the following three pieces of information:
 - the ANF-ISI PDU identification, i.e.:
 - for ANF-ISISS: the corresponding values (or the corresponding list of values) of the information elements SS type and SS PDU type (see tables 5 and 6 of ETS 300 392-9 [15]);
 - for other ANF-ISI PDUs: the corresponding value (or the corresponding list of values) of the information element PDU type.
 - the type of the first element of this PDU which was not understood;
 - the position of this element in the list of information elements of the same type present in the PDU (e.g. third type 1 element in some specific SS PDU received).
- The above three pieces of information shall be repeated in the parameter of the error invalidInfoElement for each ANF-ISI PDU in which one invalid information element has been detected by the receiving SwMI.
- unspecified.

If one error listed above has occurred, the ReturnError APDU shall be sent with the appropriate error value, and its possible associated parameter value. If more than one has occurred, the error value sent shall specify only one error, and the parameter value, the parameters possibly associated with this error. This single error shall be chosen according to their priority, this priority being defined by their rank in the above list, e.g. if the error incompleteTetraPDU has occurred (because of segmentation error), it shall be the error indicated, and if no error incompleteTetraPDU has occurred and if requestNotSupported has occurred, the latter shall be the error indicated.

8.4.4 Reject

As part of its compliance with CCITT Recommendation X.229 [10] (see subclause 8.4.1 above), each ROSE SwMI entity shall support the reject procedures specified in this recommendation. A specific use of a reject reason has been defined in subclause 8.6.

NOTE: Another example of user-reject reason is when the destination entity or source entity data elements are invalid. This case corresponds to a problem parameter of type InvokeProblem, with the value mistypedArgument.

Table 11 shows an example of encoding complementary TETRA ANF-ISIIC information element in a PSS1 SETUP message for an individual call. The column header "M/O/C" indicates which of these information elements are mandatory (M), which are optional (O) and which are conditional (C).

Table 11 : Example of encoding complementary TETRA ANF-ISIIC information element in a PSS1 SETUP message for an individual call

PSS1 SETUP message	M/O/C
Protocol discriminator	M
Call reference	M
Message type	M
Sending complete	
Bearer capability	
Channel Identification	O
Progress Indicator	O
Calling party number (note 1)	M
Calling party subaddress	-
Called party number (note 2)	M
Called party subaddress	-
Low layer compatibility	-
High layer compatibility	-
facility information element	
Identifier	M
Length	M
Protocol profile (Networking Extensions)	M
Network Facility Extension (NFE)	M
Network Protocol Profile	-
Interpretation APDU	O
Service APDU: ROSE INVOKE	
Identifier	M
Invokeld	M
LinkedId	-
OperationValue	M
ARGUMENT: tetraSiMessage	
SourceEntity	M
DestinationEntity	M
TetraMessage	
PDU Type	M
Originating SwMI MNI	M
Routing method choice	M
Call time-out, set-up phase	M
Call time-out	M
Hook method selection	M
Simplex/duplex selection	M
Basic service information	M
Speech service requested	C
Security level at calling user air interface	M
Transmission grant	M
Transmission request permission	M
Call priority	M
Called party address SSI	M (note 3)
Called party extension	M
SS-CLIR invoked for calling party	M
Calling party address SSI	M (note 3)
Calling party extension	M
External subscriber number length	M
External subscriber number digits	C
Speech services supported	O
Notification indicator	O
Proprietary	O
END of TetraMessage	
Extension	O
END of ARGUMENT	
END of Service APDU	

END of facility information element

Notification Indicator	0
END of PSS1 SETUP message	

NOTE 1:	Actually, the value put in the information element calling party number will be a PISN number in the range of numbers allocated to the originating SwMI.
NOTE 2:	Actually, the value put in the information element calling party number will be a PISN number in the range of numbers allocated to the called SwMI.
NOTE 3:	SSI = Short Subscriber Identity.

8.5 Segmentation Service Entity (SSE)

The SSE shall take ROSE APDUs divide them into segments which fit into a single facility information element and send these segments in SSE APDUs to the peer SSE. The peer SSE shall re-assemble the original ROSE APDU and deliver it to the destination ROSE entity.

The length of a segment is related to the maximum length of a facility information element (which is 255 octets, see ISO/IEC 11582 [4], subclause 11.3.3) and it depends on the maximum length of a layer 2 PDU. As a result, the segment length varies, see annex B.

8.5.1 Procedures

This subclause specifies two functions for the SSE: segmentation and re-assembly. Segmentation procedures shall not be applied to messages which fit into a single facility information element. This procedures are based on segmentation and re-assembly function defined in annex ZA of ISO/IEC 11572 [3]. ROSE APDU sent in a PSS1 basic call message shall not be segmented.

8.5.1.1 Requirements for the segmentation procedure

Once the first segment has been transmitted to GFT control, then all remaining segments of that message shall be sent in order, before any other ROSE APDU (segmented or not). After sending a segment, the timer T1 shall be started and before its expire the subsequent segment shall be sent. Only failure conditions (e.g. GFT control failure or timer T1 time-out) shall cause the transmission of a segmented ROSE APDU to be aborted.

The ROSE message identifier field in the segmented message shall identify the ROSE APDU to which the segment belongs; this identifier is uniquely defined by the SSE and it is not related to the invoked included in the ROSE APDU.

The remaining segments field of the segmented message information element shall indicate how many more segments are to be sent.

The octet order of the segmented ROSE APDU shall be preserved regardless of segment boundary.

The protocol timer definition in table 12 shall apply for the segmentation procedures.

Table 12: Timer definition for segmentation procedure

Timer number	Timer value	Cause for start	Normally terminated	Action to be taken when timer expires	Status
T1	Max. 100 ms	Message segment sent	Subsequent segment message sent	Transmission of the segmented ROSE APDU aborted	Mandatory

8.5.1.2 Requirements for the re-assembly procedure

The re-assembly function on receiving a segment in which the remaining segments field is not set to zero (last segment of a segmented ROSE APDU) shall save the segment contents and shall start a timer T2.

NOTE: This timer T2 is used to prevent the re-assembly function waiting indefinitely to receive the next message segment.

SSE shall be able to re-assemble received segments of any size.

When receiving an invalid segment, the SSE shall discard this segment and send the incomplete message to ROSE entity. A Reject APDU or a ReturnError APDU with the value IncompleteTetraPDU shall also be send to the source SwMI.

An invalid segment could be one of the following:

- segment in which the number of remaining segment field of the segmented message has a value which is not one less than the value of the previously received segment;
- segment which is not the first segment of a segmented ROSE APDU with an identifier value different from that in the previously received segment.

On expiry of timer T2, the re-assembly function shall send any saved segment to ROSE entity and inform it at the same time that the transmitted message is incomplete. The re-sending of the ROSE APDU is an implementation matter.

The protocol timer definition in table 13 shall apply for the re-assembly procedures.

Table 13: Timer definition for re-assembly procedure

Timer number	Timer value	Cause for start	Normally terminated	Action to be taken when timer expires	Status
T2	Max. 200 ms	Message segment received	Last message segment received	Send message to ROSE with error handling	Mandatory

8.5.2 Segment encoding

SSE segment shall be included in a facility information element as defined in ISO/IEC 11582 [4], subclause 11.3.3, however some modifications need to be done to the present document. A new value of network protocol profile information element, as shown in table 14 is to be allocated, in order to indicate that service APDU included is an SSE APDU.

Table 14: Network protocol profile

<pre> Network-Protocol-Profile-definition { iso(1) standard (0) pss1-generic-procedures (11582) network-protocol-profile-definition(8)} DEFINITIONS ::= BEGIN EXPORTS NetworkProtocolProfile; NetworkProtocolProfile ::= [18] IMPLICIT INTEGER { acse(19) dse (32) tetraSse(39) } (0..254) END -- of Network Protocol Profile definition </pre>

Obviously, only one SSE APDU can be included in the service APDU of the facility information element. When a SSE APDU is included, the protocol profile value of the facility information element shall be set to Networking Extensions and the NFE shall be included.

A SSE APDU shall comprise ASN.1 type as defined in table 15.

Table 15: ASN.1 definition of SSE APDU

<pre> Sse-Apdu-definition { ccitt (0) identified-organization (4) etsi (0) tetra(392) sse-apdu(1)} DEFINITIONS ::= BEGIN EXPORTS SseApdu SseApdu ::= [39] IMPLICIT OCTET STRING END -- of SSE APDU definition </pre>

The structure of the octet string included in SSE APDU shall be as defined in table 16.

Table 16: Structure of SSE APDU

Information element	Length	Type	C/O/M	Remark
ROSE message identifier	8	1	M	Identifies the ROSE APDU the segment belongs to (note 1).
Remaining segments	8	1	M	Indicates how many segments follow (note 2).
Data		1	M	Segment of the ROSE APDU (note 3).
NOTE 1:	The message identifier is assigned by the sending SSE. It shall be unique on that signalling connection and can be reused when the transfer of the respective ROSE APDU has been completed.			
NOTE 2:	The counter provides a means to verify the proper transmission of the ROSE APDU. It shall count down to 0, thus indicating the last segment.			
NOTE 3:	To generate the data segment, the SSE shall interpret the Basic Encoding Rules (see CCITT Recommendation X.209 [11]) encoded ROSE APDU as a bit string.			

8.6 Co-ordination function

The co-ordination function provides co-ordination between GFT control, the different ANF entities, ROSE entity and the SSE. This co-ordination includes the delivery of information received from the GFT control to its destination entity. The relationships it co-ordinates are beyond the scope of the present document. It also provides functions to support the handling of unrecognized APDUs.

When a ROSE Invoke APDU is addressed to an ANF-ISI entity which is not present in the receiving SwMI, the co-ordination function shall request the ROSE entity to generate a Reject APDU of type InvokeProblem with the value unrecognizedOperation.

In addition, the co-ordination function requirements defined in ISO/IEC 11582 [4], subclause 8.1 shall apply. Notably, according to ISO/IEC 11582 [4], subclause 8.1.2, when the ROSE entity has generated a Reject APDU of type InvokeProblem with the value unrecognizedOperation as a result of an Invoke APDU sent in a facility information element with an Interpretation APDU with the value clearCallIfAnyInvokePduNotRecognised, the co-ordination function will clear the TETRA call or the call independent signalling connection. It will also ensure that the Reject APDU is delivered to its destination.

NOTE: As a consequence of the two preceding paragraphs, when such interpretation APDU has been included in a facility information carrying an Invoke APDU addressed to a non-existing ANF-ISI entity during a inter-TETRA call, the co-ordination function will clear this call.

9 Security over the ISI

Authentication and encryption of the connections used between SwMIs are outside the scope of TETRA standardization. However ITSI authentication, end-to-end encryption and end-to-end key management have impact on the ISI.

In addition, the specific requirements on ANF-ISIMM to support air interface encryption in a visited SwMI for an individual subscriber when this SwMI is different from its home SwMI are defined in annex A. This annex includes also a supporting explanation for the various possible types of cipher key which may be used at the air interface, and their relationship with authentication.

9.1 ITSI authentication

The ITSI authentication procedure may be used to authenticate a migrated (individual) subscriber or the subscriber's home SwMI or both. The authentication procedure may be initiated by the migrated subscriber or by the visited SwMI. Thus, the authentication procedures as defined in ETS 300 392-7 [8], clause 4, may be extended over the ISI and used to authenticate a migrated subscriber or his home SwMI.

NOTE 1: Formally it is the home SwMI that authenticates the subscriber as it provides the visited SwMI with the authentication parameters. However, by acting as an agent to the authentication process the visited SwMI is implicitly authenticated.

NOTE 2: In a symmetric key authentication process there is authentication only between the holders of the key (in this case the MS and the home SwMI of that MS). In the case of ISI, the visited SwMI is an intermediary to which the home SwMI has distributed its management function. Upon distribution, the visited SwMI is a trusted party having the responsibility of the authentication process.

When invoked, the home SwMI shall send the authentication parameters over the ISI to the visited SwMI. The transported authentication parameters are the session authentication key (K) for the MS and for the SwMI (KS and KS', respectively) and a Random Seed (RS) used to seed the authentication algorithm. These parameters may be used once or several times in the visited SwMI, as indicated by the home SwMI.

9.2 End-to-End encryption

There is no end-to-end encryption algorithm or method defined for TETRA. However a mechanism is described to support the synchronization of synchronous stream ciphers, with synchronization data sent interspersed with the encrypted voice or data traffic. The frequency at which such signalling can be sent is defined in ETS 300 392-7 [8], clause 7. This synchronization data has to be correlated in a bit exact manner to the encrypted traffic. This is ensured at the air interface by using the frame stealing mechanism. To ensure it over the ISI, an in-band signalling method shall be used between the source and the destination SwMIs. This method shall be such that the destination SwMI of the call shall receive stolen frames from the source SwMI in such a sequence that it shall be able to correctly transmit these across the air interface, i.e. the exact relation between stolen frames and the first and second half slots of a timeslot shall be maintained.

This implies that frame and timeslot boundaries, and ordering, shall be retained across the ISI for end-to-end encrypted calls.

NOTE: A similar requirement exists for voice calls, between TETRA codecs (see ETS 300 395-1 [12]).

9.3 End-to-end key management via ISI

The TETRA security standard, ETS 300 392-7 [8], subclause 7.6, provides a means of transporting end-to-end key management material over the air interface by use of short data messages. The quantity of data transported is 2 047 bits minus a data type identifier, which corresponds to the maximum length of a type 4 short data message. To allow the extension of such messages over the ISI between SwMIs, ANF-ISISDS shall be supported.

Annex A (normative): Security - supporting encryption over ISI

This annex describes the support of air interface encryption by transmission of security parameters over the ISI. The material presented here also describes the major differences between support of security functions over the ISI, and the support of the same functionality at the air interface.

A.1 Overview

Air interface encryption takes place in layer 2 of the air interface protocol stack. The layer 3 authentication service, embedded in MM, can provide a cipher key to layer 2 that is strongly bound to authentication (i.e. it allows implicit authentication of all messages sent that are encrypted using this key). In addition the layer 3 OTAR service, embedded in MM, can provide cipher keys to layer 2.

The air interface authentication mechanism uses a secret key schema that ensures that the K, is known only to the AC and the user. In order to enable authentication of migrated users, the home SwMI and the visited SwMI shall support the ANF-ISIMM functionality allowing authentication of a subscriber in a visited SwMI. As described in subclause A.2.2.2, at the same time, this will allow the visited SwMI to support the air interface encryption service using Derived Cipher Key (DCK) for a migrated user. If, instead of this air interface encryption service, the visited SwMI supports the air interface encryption service using Static Cipher Key (SCK) (see subclause A.2.2.4), in order to enable migrated users to use this service, the home SwMI and the visited SwMI shall support ANF-ISIMM functionality OTAR SCK for a subscriber in a visited SwMI.

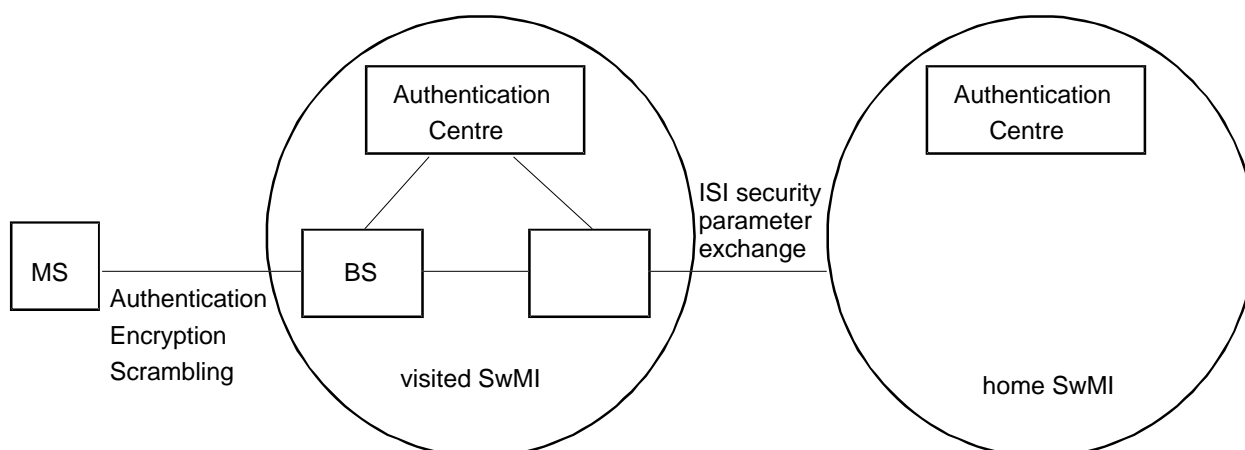

NOTE: BS = Base Station

Figure A.1: Overview of ISI in place within TETRA

In figure A.1 the AC holds the ITSI/secret key K relationship and is a trusted part of the SwMI, see ETS 300 392-7 [8]. By authenticating the individual subscriber to the network and then using the authentication process to derive an encryption key the air-interface is made secure and this individual subscriber becomes trusted. The ISI is not secure although it is allowed to carry authentication parameters and signalling data. The corresponding ISI path is implicitly trusted if authentication is successful.

When migrating, an individual subscriber may have to be authenticated to the visited SwMI. This shall be achieved by the ISI supporting transport of authentication parameters from home SwMI to visited SwMI.

A.2 Encryption

A.2.1 ISI relation to air interface and end-to-end encryption

The air interface encryption system in TETRA (see ETS 300 392-7 [8]) operates on the radio link between individual subscriber and BSs of the SwMI. The cipher keys may be dynamically derived. Encryption synchronization will be derived from the frame numbering system. As this encryption applies at the air interface, information will be decrypted at the BSs of the SwMI, and therefore will be unencrypted at point of presentation to the ISI.

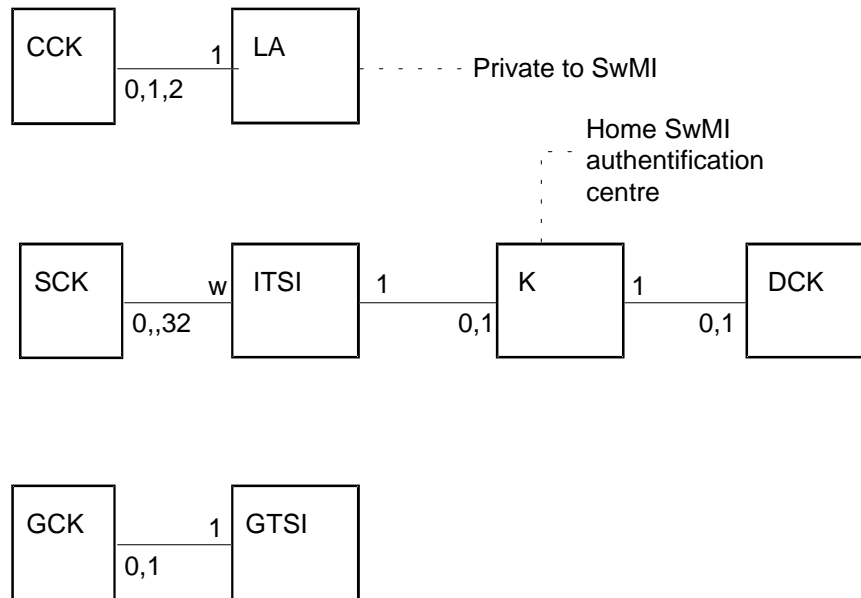

- NOTE 1: The relation between the SCK and ITSI allows up to 32 keys to be associated with any ITSI but SCKs may not be shared among ITSIs.
- NOTE 2: Only one Common Cipher Key (CCK) shall be in use at one time in an LA.
- NOTE 3: The cardinality of each relation is shown by the figures attached to each link, e.g. an ITSI can have 1 or 0 keys K, and K can be associated with only one ITSI. An open relation is shown by a letter (e.g. "w" for SCK to ITSI).

Figure A.2: Mapping of cipher key and TETRA address relationships

In order to use encryption at the air interface, the serving BS and the individual subscriber shall have the same keys. Figure A.2 shows the relation of cipher keys to addresses. For the ISI to be invoked for the transfer of a key, and for the air interface service OTAR to be invoked, the address use has to be allowed in the visited SwMI.

End-to-end encrypted traffic between individual subscribers shall remain encrypted across the ISI. End-to-end encryption does not encrypt signalling.

A.2.2 Air interface encryption key management via ISI.

In ETS 300 392-7 [8] a mechanism of key management over the air interface is described i.e. OTAR. This mechanism allows the SwMI to distribute keys to individual subscribers. Each key is sealed prior to distribution: i.e. it is packaged in an encrypted form where the key to be used is derived from the secret key K.

The keys that are used for air interface encryption are described in relationship to the ISI in the following subclauses.

- NOTE: This description is given in more detail in the ETS defining ANF-ISIMM.

A.2.2.1 Secret Key of individual subscriber (K)

K shall not be transferred over the ISI.

A.2.2.2 Derived Cipher Key (DCK)

Authentication is a prerequisite of DCK.

The DCK shall be generated within the SwMI where the individual subscriber has requested registration. It shall not be valid in a different SwMI, and shall be generated afresh by authentication when an individual subscriber requests registration in a new SwMI. It shall not be transferred across the ISI.

In order to support the use of DCK in the visited SwMI ANF-ISIMM shall support the transfer of DCK generator parameters from the AC of the home SwMI of the migrated individual subscriber. These parameters shall consist of the session key for individual subscriber authentication, the session key for SwMI authentication and the random seed. These parameters are used in the authentication algorithms which as an output of successful authentication allow DCK to be generated. The terms authentication parameters and DCK generator parameters are equivalent and should be used to reflect the user intention.

A.2.2.3 Common Cipher Key (CCK)

Authentication is a prerequisite of CCK.

The CCK shall be generated within a SwMI and shall be valid within one or more LAs of that SwMI. It shall not be known within a different SwMI. If an individual subscriber migrates and request registration in a new SwMI, it shall be authenticated by this SwMI, and obtain the relevant CCK within that new SwMI. The CCK shall not be transported via the ISI.

A.2.2.4 Static Cipher Key (SCK)

The SCK may be valid in many SwMIs and may require to be modified from the home SwMI across the ISI. In addition the visited SwMI may require to distribute versions of SCK to all registered users of its SwMI.

The visited SwMI may generate SCK locally. In order to distribute this locally generated SCK, ANF-ISIMM shall support the transfer from the home SwMI to the visited SwMI of parameters to allow the SCK to be sealed. These parameters shall be:

- Session Key for OTAR; and
- RS for OTAR.

The home SwMI may wish to distribute a new SCK to a migrated subscriber. Such a key shall not be used by the visited SwMI, but only in the home SwMI. The home SwMI shall then request ANF-ISIMM to transfer the sealed key and the parameters to allow the migrated individual subscriber to unseal it. These parameters shall be:

- RS for OTAR;
- SCK number; and
- SCK Version Number.

A.2.2.5 Group Cipher Key (GCK)

Authentication is a prerequisite of GCK.

For secure group calls in a SwMI there shall be a key, GCK, associated with the group address (GTSI).

In a visited SwMI a GCK shall only be used if it is generated and assigned by the visited SwMI. This shall not invoke ANF-ISIMM.

Annex B (informative): Maximum length of a ROSE APDU or a SSE segment encoded in a facility information element

The maximum length of a ROSE APDU or a SSE segment is related to the maximum length of a facility information element (which is 255 octets see ISO/IEC 11582 [4], subclause 11.3.3) and it depends also on the maximum length provided for by PSS1 segmentation (see annex ZA of ISO/IEC 11572 [3]). The minimum length of the PSS1 PDU ensured by this segmentation is 260 octets.

Some examples of the maximum lengths of ROSE APDUs or a SSE segments encoded in a facility information element in different PSS1 messages are given in the following subclauses. The hypothesis taken is that the maximum possible length of PSS1 messages is only 260 octets.

In the tables the column header "M/O" indicates which of these information elements are mandatory (M), which are optional (O). The column headed "Length" indicates the length of the information elements in octets.

B.1 Call unrelated PSS1 FACILITY message

Table B.1 shows an example of encoding a ROSE APDU or a SSE segment in a call unrelated PSS1 FACILITY message.

Table B.1: Example of encoding a ROSE APDU or a SSE segment in a call unrelated PSS1 FACILITY message

PSS1 FACILITY message	M/O	Length	Note
Protocol discriminator	M	1	
Call reference	M	1	
Message type	M	1	
Facility information element			
Identifier	M	1	
Length	M	1	
Protocol profile (Networking Extensions)	M	1	
NFE	M	8	1
Network Prot Profile	O	0/3	2
Interpretation APDU	O	0	3
Service APDU: ROSE APDU or SSE Segment			
END of facility information element			
END of PSS1 FACILITY message			

NOTE 1: The length of 8 octets indicated in the table for the NFE information corresponds to the case where the destinationEntity and the sourceEntity data elements both contain the value endPINX.

NOTE 2: The Network protocol profile is not included for a ROSE APDU (0 octet). It is included for SSE segment, in that case it is encoded in 3 octets.

NOTE 3: The Interpretation APDU information element may be omitted or included with the value "rejectAnyUnrecognisedInvokedPdu". In this example it is omitted.

In order to encode a ROSE APDU in a call unrelated FACILITY message, 14 octets are used for the encoding of the PSS1 message and for the encoding of the facility information element. Due to the limit of 260 octets, the maximum length for a ROSE APDU is 246 octets. In the case of SSE segment, the maximum length is 243 octets.

B.2 Call related PSS1 FACILITY message

Table B.2 shows an example of encoding a ROSE APDU or a SSE segment in a call related PSS1 FACILITY message.

Table B.2: Example of encoding a ROSE APDU or a SSE segment in a call related PSS1 FACILITY message

PSS1 FACILITY message	M/O	Length	Note
Protocol discriminator	M	1	
Call reference	M	3	1
Message type	M	1	
Facility information element			
Identifier	M	1	
Length	M	1	
Protocol profile (Networking Extensions)	M	1	
NFE	M	8	2
Network Prot Profile	O	0/3	3
Interpretation APDU	O	0	4
Service APDU: ROSE APDU or SSE Segment			
END of facility information element			
END of PSS1 FACILITY message			

NOTE 1:	In call related message the call reference value is encoded in 3 octets.
NOTE 2:	The length of 8 octets indicated in the table for the NFE information corresponds to the case where the destinationEntity and the sourceEntity data elements both contain the value endPINX.
NOTE 3:	The Network protocol profile is not included for a ROSE APDU (0 octet). It is included for SSE segment, in that case it is encoded in 3 octets.
NOTE 4:	The Interpretation APDU information element may be omitted or included with the value "rejectAnyUnrecognisedInvokedPdu". In this example it is omitted.

The difference with the preceding example (call unrelated FACILITY message) is the length of the call reference which is encoded in 3 octets instead of 1 octet. The maximum length for a ROSE APDU is 244 octets. In the case of SSE segment, the maximum length is 241 octets.

B.3 ANF-ISIIC PSS1 basic call message

In a PSS1 basic call message, there are more data elements compared to the FACILITY message. It is assumed that the SETUP message is the more critical message for the length. Table B.3 shows an example of encoding a ROSE APDU sent in an ANF-ISIIC PSS1 SETUP message for an individual call.

**Table B.3: Example of encoding a ROSE APDU
in a PSS1 SETUP message for an individual call**

PSS1 SETUP message	M/O	Length	Note
Protocol discriminator	M	1	
Call reference	M	3	1
Message type	M	1	
Sending complete	O	1	
Bearer capability	M	4	
Channel Id	M	6	
Progress	O	0	2
Calling PN (SwMI PISN)	M	21	3
Calling subaddress	-	0	
Called PN (SwMI PISN)	M	21	3
Called subaddress	-	0	
Low layer compatibility	-	0	
High layer compatibility	-	0	
Facility information element			
Identifier	M	1	
Length	M	1	
Protocol profile (Networking Extensions)	M	M	1
NFE	M	8	4
Network Prot Profile	-	0	
Interpretation APDU	O	3	5
Service APDU: ROSE APDU			
END of facility information element			
END of PSS1 SETUP message			

NOTE 1:	The call reference is encoded in 3 octets because the PSS1 message is call related.
NOTE 2:	In this example it is proposed not to include optional information element.
NOTE 3:	According to ITU-T Recommendation E.164, as well as to CCITT Recommendation E.163 (1988), the maximum length of a PSTN international number is 15 digits (and 12 for a national number), then it is necessary to add 3 digits for the prefix before the international number. The length of the heading (identifiers, length) of the PSS1 information elements calling party number and called party number is 3 octets, to which we add 1 octet per digit.
NOTE 4:	The length of 8 octets indicated in the table for the NFE information corresponds to the case where the destinationEntity and the sourceEntity data elements both contain the value endPINX.
NOTE 5:	The Interpretation APDU information element shall be included with the value "clearCallIfAnyInvokedPduNotRecognised".

In order to encode a ROSE APDU in a call unrelated FACILITY message, 72 octets are used for the encoding of the PSS1 message and for the encoding of the facility information element. Due to the limit of 260 octets, then the maximum length for a ROSE APDU sent in an ANF-ISIIC PSS1 SETUP message for an individual call is 188 octets.

History

Document history	
February 1998	Public Enquiry PE 9826: 1998-02-27 to 1998-06-26