



EUROPEAN
TELECOMMUNICATION
STANDARD

ETS 300 390

February 1996

Source: ETSI TC-RES

Reference: DE/RES-02-04

ICS: 33.060.20, 33.060.50

Key words: Data, mobile, radio, testing

**Radio Equipment and Systems (RES);
Land mobile service;
Technical characteristics and test conditions
for radio equipment intended for the
transmission of data (and speech)
and using an integral antenna**

ETSI

European Telecommunications Standards Institute

ETSI Secretariat

Postal address: F-06921 Sophia Antipolis CEDEX - FRANCE

Office address: 650 Route des Lucioles - Sophia Antipolis - Valbonne - FRANCE

X.400: c=fr, a=atlas, p=etsi, s=secretariat - **Internet:** secretariat@etsi.fr

Tel.: +33 92 94 42 00 - Fax: +33 93 65 47 16

*

Copyright Notification: No part may be reproduced except as authorized by written permission. The copyright and the foregoing restriction extend to reproduction in all media.

© European Telecommunications Standards Institute 1996. All rights reserved.

Contents

Foreword	9
Introduction	10
1 Scope	11
2 Normative references	12
3 Definitions, abbreviations and symbols	13
3.1 Definitions	13
3.2 Abbreviations	14
3.3 Symbols	14
4 General	14
4.1 Presentation of equipment for testing purposes	15
4.1.1 Choice of model for type approval	15
4.1.2 Definitions of alignment range and switching range	16
4.1.3 Definition of the categories of the alignment range (AR1 and AR2)	16
4.1.4 Choice of frequencies	16
4.1.5 Testing of single channel equipment of category AR1	16
4.1.6 Testing of single channel equipment of category AR2	16
4.1.7 Testing of two channel equipment of category AR1	16
4.1.8 Testing of two channel equipment of category AR2	17
4.1.9 Testing of multi channel equipment (more than two channels) of category AR1	17
4.1.10 Testing of multi channel equipment (more than two channels) of category AR2 (switching range less than alignment range)	17
4.1.11 Testing of multi channel equipment (more than two channels) of category AR2 (switching range equals the alignment range)	18
4.2 Mechanical and electrical design	18
4.2.1 General	18
4.2.2 Controls	18
4.2.3 Transmitter shut-off facility	18
4.2.4 Marking	18
4.3 Testing using bit streams or messages	18
4.4 Interpretation of the measurement results	18
5 Technical characteristics	19
5.1 Transmitter parameter limits	19
5.1.1 Frequency error	19
5.1.2 Effective radiated power	19
5.1.2.1 Effective radiated power under normal test conditions	19
5.1.2.2 Effective radiated power under extreme test conditions	20
5.1.3 Adjacent channel power	20
5.1.4 Radiated spurious emissions	20
5.1.5 Transmitter attack time	20
5.1.6 Transmitter release time	21
5.1.7 Transient behaviour of the transmitter	21
5.1.7.1 Time domain analysis of power and frequency	21
5.1.7.2 Adjacent channel transient power	21
5.2 Receiver parameter limits	21
5.2.1 Average usable sensitivity (field strength, data or messages)	21
5.2.2 Error behaviour at high input levels	22
5.2.3 Co-channel rejection	22
5.2.4 Adjacent channel selectivity	22
5.2.5 Spurious response rejection	23
5.2.6 Intermodulation response rejection	23

	5.2.7	Blocking or desensitisation	23
	5.2.8	Spurious radiations	23
6		Test conditions, power sources and ambient temperatures	24
	6.1	Normal and extreme test conditions.....	24
	6.2	Test power source.....	24
	6.3	Normal test conditions.....	24
	6.3.1	Normal temperature and humidity	24
	6.3.2	Normal test power source.....	24
		6.3.2.1 Mains voltage	24
		6.3.2.2 Regulated lead-acid battery power sources used on vehicles	24
		6.3.2.3 Other power sources.....	24
	6.4	Extreme test conditions.....	25
	6.4.1	Extreme temperatures	25
	6.4.2	Extreme test source voltages	25
		6.4.2.1 Mains voltage	25
		6.4.2.2 Regulated lead-acid battery power sources used on vehicles	25
		6.4.2.3 Power sources using other types of batteries	25
		6.4.2.4 Other power sources.....	25
	6.5	Procedure for tests at extreme temperatures	25
	6.5.1	Procedure for equipment designed for continuous operation.....	26
	6.5.2	Procedure for equipment designed for intermittent operation	26
7		General conditions.....	26
	7.1	Normal test signals (wanted and unwanted signals).....	26
		7.1.1 Signals for bit stream measurements.....	26
		7.1.2 Signals for messages	27
	7.2	Artificial antenna.....	27
	7.3	Test sites and general arrangements for radiated measurements	27
	7.4	Transmitter automatic shut-off facility	27
	7.5	Modes of operation of the transmitter	27
	7.6	Encoder for receiver measurements.....	28
	7.7	Transceiver data interface.....	28
	7.8	Arrangements for test signals at the input of the receiver via a test fixture or a test antenna	28
	7.9	Facilities for access.....	28
		7.9.1 Analogue access	28
		7.9.2 Points for bit stream measurement	28
		7.9.3 Coupling arrangements	29
		7.9.3.1 Arrangements for measurements with continuous bit streams	29
		7.9.3.2 Arrangements for measurements with messages	29
	7.10	Message received indicator.....	29
	7.11	Reset.....	29
	7.12	Reset time	29
	7.13	Receiver mute or squelch facility.....	29
8		Methods of measurement for transmitter parameters	30
	8.1	Frequency error.....	30
		8.1.1 Definition.....	30
		8.1.2 Method of measurement.....	30
	8.2	Effective radiated power.....	30
		8.2.1 Definition.....	30
		8.2.2.1 Maximum effective radiated power under normal test conditions	31
		8.2.2.2 Average effective radiated power under normal test conditions	33
		8.2.2.3 Method of measurements of maximum and average effective radiated power under extreme test conditions.....	33
	8.3	Adjacent channel power	33
		8.3.1 Definition.....	33

	8.3.2	Method of measurement	34	
8.4		Radiated spurious emissions.....	35	
	8.4.1	Definition	35	
	8.4.2	Method of measurement	35	
8.5		Transmitter attack time	38	
	8.5.1	Definition	38	
	8.5.2	Method of measurement	38	
8.6		Transmitter release time	38	
	8.6.1	Definition	38	
	8.6.2	Method of measurement	39	
8.7		Transient behaviour of the transmitter	39	
	8.7.1	Definitions.....	39	
	8.7.2	Timings, frequencies and powers	40	
	8.7.3	Methods of measurement	43	
		8.7.3.1 Time and frequency domain analysis measurements	44	
		8.7.3.2 Test arrangement and characteristics of the test discriminator	45	
		8.7.3.3 Adjacent channel transient power measurements	45	
		8.7.3.4 Characteristics of the adjacent channel transient power measuring device	46	
9		Methods of measurement for receiver parameters.....	46	
	9.1	Average usable sensitivity (field strength, data or messages).....	46	
		9.1.1 Definition	46	
		9.1.2 Method of measurement with continuous bit streams under normal test conditions	47	
		9.1.3 Method of measurement with continuous bits streams under extreme test conditions	48	
		9.1.4 Method of measurement with messages under normal test conditions	49	
		9.1.5 Method of measurement with messages under extreme test conditions	50	
		9.1.6 Reference for degradation measurements	51	
			9.1.6.1 Definition.....	51
			9.1.6.2 Procedures for measurements using the test fixture.....	51
			9.1.6.3 Procedures for measurements on a test site.....	52
	9.2	Error behaviour at high input levels	52	
		9.2.1 Definition	52	
		9.2.2 Method of measurement with continuous bit streams.....	52	
		9.2.3 Method of measurement with messages	53	
	9.3	Co-channel rejection.....	53	
		9.3.1 Definition	53	
		9.3.2 Method of measurement with continuous bit streams.....	53	
		9.3.3 Method of measurement with messages	54	
	9.4	Adjacent channel selectivity	55	
		9.4.1 Definition	55	
		9.4.2 Method of measurement with continuous bit streams.....	56	
		9.4.3 Method of measurement with messages	57	
	9.5	Spurious response rejection	58	
		9.5.1 Definition	58	
		9.5.2 Introduction to the method of measurement	58	
		9.5.3 Measurement arrangement.....	59	
		9.5.4 Method of the search over the limited frequency range with continuous bit streams.....	60	
		9.5.5 Method of the search over the limited frequency range with messages	60	
		9.5.6 Method of measurement with continuous bit streams.....	61	
		9.5.7 Method of measurement with messages	62	
	9.6	Intermodulation response rejection.....	63	
		9.6.1 Definition	63	
		9.6.2 Method of measurement with continuous bit streams.....	63	
		9.6.3 Method of measurement with messages	64	
	9.7	Blocking or desensitisation	65	
		9.7.1 Definition	66	
		9.7.2 Method of measurement with continuous bit streams.....	66	
		9.7.3 Method of measurement with messages	68	

9.8	Spurious radiations.....	69
9.8.1	Definition.....	69
9.8.2	Method of measurement.....	70
10	Measurement uncertainty.....	72
Annex A (normative):	Radiated measurements.....	73
A.1	Test sites and general arrangements for measurements involving the use of radiated fields.....	73
A.1.1	Open air test site.....	73
A.1.1.1	Description.....	73
A.1.1.2	Establishment of a relationship between signal levels and field strength.....	73
A.1.2	Anechoic chamber.....	74
A.1.2.1	General.....	74
A.1.2.2	Description.....	74
A.1.2.3	Influence of parasitic reflections.....	75
A.1.2.4	Mode of use.....	75
A.1.3	Stripline arrangement.....	77
A.1.3.1	General.....	77
A.1.3.2	Description.....	77
A.1.3.3	Calibration.....	77
A.1.3.4	Mode of use.....	77
A.1.4	Indoor test site.....	77
A.1.4.1	Description.....	77
A.1.4.2	Test for parasitic reflections.....	78
A.1.4.3	Mode of use.....	78
A.2	Standard position.....	78
A.3	Acoustic coupler.....	79
A.3.1	General.....	79
A.3.2	Description.....	79
A.3.3	Calibration.....	79
A.4	Test antenna.....	80
A.5	Substitution antenna.....	80
A.6	Test fixture.....	81
A.6.1	Description.....	81
A.6.2	Calibration.....	81
A.6.3	Mode of use.....	82
Annex B (normative):	Specifications for adjacent channel power measurement arrangements.....	83
B.1	Power measuring receiver specification.....	83
B.1.1	General.....	83
B.1.2	IF filter.....	83
B.1.3	Oscillator and amplifier.....	85
B.1.4	Attenuation indicator.....	85
B.1.5	Level indicators.....	85
B.1.5.1	Rms level indicator.....	85
B.1.5.2	Peak level indicator.....	85
B.2	Spectrum analyser specification.....	85
B.3	Integrating and power summing device.....	86
Annex C (normative):	Identification.....	87
C.1	Scope.....	87
C.2	General.....	87

C.3	Position of the identification code.....	87
C.3.1	Base stations	87
C.3.1.1	System without windows	88
C.3.1.2	Systems with windows.....	88
C.3.2	Handportable and mobile stations	88
C.4	Bit rates and modulations.....	88
C.5	Format of the identification	89
C.6	Synchronisation.....	90
C.7	Code and block length.....	90
C.8	Contents of the identification block	91
C.8.1	Header	91
C.8.2	Country code.....	91
C.8.3	National Information.....	92
C.8.3.1	Field description	92
C.8.3.2	Field size options.....	93
C.8.3.3	Options for the organisation of the fields.....	93
C.8.3.4	Examples of user/system information usage	94
C.9	Combinations	94
C.9.1	List of possible combinations.....	94
C.9.2	Relations between country code and allowed combinations	94
C.9.3	Interpretation of the fields of the ID block	95
Annex D (informative):	Graphic representation of selection of equipment and frequencies for testing ..	97
Annex E (informative):	Information on modulation, coding and format.....	99
Annex F (informative):	Bibliography.....	100
History.....		101

Blank page

Foreword

This European Telecommunication Standard (ETS) has been prepared by the Radio Equipment and Systems (RES) Technical Committee of the European Telecommunications Standards Institute (ETSI).

The ETS is a general standard which may be superseded by specific standards covering specific applications.

This ETS is complementary to I-ETS 300 113 [2] and ETS 300 113 [10] which cover digital and combined analogue and digital radio equipment with an internal or external RF connector for use in the land mobile service. It is primarily intended for omnidirectional applications.

For combined analogue speech/data equipment, this ETS is complementary to ETS 300 296 [6] which covers radio equipment using an integral antenna or use in the land mobile service and intended primarily for analogue speech.

Integral antenna equipment transmitting signals to initiate a response in the receiver is covered by ETS 300 341 [7].

Annex A is normative and provides additional information concerning radiated measurements. Detailed descriptions of the radiated measurement arrangements are included in this annex. It is common to several (I-)ETSS, in particular covering analogue speech equipment.

Annex B is normative and gives the requirements for equipment to be used for the measurement of adjacent channel power.

Annex C is normative and presents the technical characteristics to be fulfilled, when required by the appropriate national regulatory authority, for the identification of stations type approved for private mobile radio systems, that do not comply with other system protocols (e.g. trunking protocols); it is the responsibility of the manufacturer to ensure that the modulation that he has chosen for the identification, in accordance with the tables of this annex fulfils the requirements corresponding to the channels where the equipment is designed to operate, as specified in the main body of this ETS. The tables of this annex are expected to be updated regularly in order to reflect the progress accomplished in the field of mobile data transmissions.

Annex D is informative and gives a graphic representation of the subclause 4.1, referring to the presentation of equipment for testing purposes.

Annex E is informative and provides guidance concerning the technical characteristics of the modulation, coding and format.

Annex F is informative and contains a bibliography.

Transposition dates	
Date of adoption of this ETS:	17 November 1995
Date of latest announcement of this ETS (doa):	30 May 1996
Date of latest publication of new National Standard or endorsement of this ETS (dop/e):	28 November 1996
Date of withdrawal of any conflicting National Standard (dow):	28 November 1996

Introduction

This ETS is intended to specify the minimum performance and the methods of measurement of radio equipment for use in the land mobile service as specified in the scope.

The methods of measurement have been adapted from ETR 027 [3], I-ETS 300 113 [2], ETS 300 296 [6] and ETS 300 341 [7] as appropriate.

Clause 5 provides the corresponding limits. These limits have been chosen to ensure an acceptable grade of service and to minimise harmful interference to other equipment and services. They are based on the interpretation of the measurement results described in subclause 4.4.

Constant envelope modulation should be used for radio equipment covered by this ETS, but individual national administrations are free to choose the type of modulation. Channel separations, maximum transmitter output power/effective radiated power and the inclusion of automatic transmitter shut-off facility may all be conditions attached to the issue of a licence by the appropriate administration.

This ETS may be used by accredited test laboratories for the assessment of the performance of the equipment. The performance of the equipment submitted for type testing should be representative of the performance of the corresponding production model. In order to avoid any ambiguity in that assessment, this ETS contains instructions for the presentation of equipment for type testing purposes in clause 4, conditions in clause 6 and methods of measurement in clauses 8 and 9.

This ETS may also be used by monitoring services in particular for the identification of stations (annex C).

Equipment built according to this ETS can be designed to support the BISS 1200 protocol (I-ETS 300 230 [8]).

This ETS was drafted on the assumption that:

the type test measurements performed in an accredited test laboratory in one country are accepted by the administration in another country provided that the national regulatory requirements are met (in accordance to CEPT Recommendation T/R 71-03 [9]);

if equipment available on the market is required to be checked it is tested in accordance with the methods of measurement specified in this ETS.

1 Scope

This ETS covers the minimum characteristics considered necessary in order to make the best use of the available frequencies. It does not necessarily include all the characteristics which may be required by a user, nor does it necessarily represent the optimum performance achievable.

This ETS applies to constant envelope angle modulation systems for use in the land mobile service, using the available bandwidth, operating on radio frequencies between 30 MHz and 1 000 MHz, with channel separations of 12,5 kHz, 20 kHz and 25 kHz intended for data transmissions. It applies to digital and combined analogue and digital radio equipment which is hand portable, using an integral antenna and intended for the transmission of data and/or speech.

The technical characteristics given in this ETS are independent of data rate but may in practice limit the maximum data rate achievable. Future editions of this ETS may be prepared which may allow complex modulation methods, together with their appropriate limits, for use at higher bit rates.

In this ETS, a digital radio equipment is defined as a radio equipment which transmits and/or receives data.

Data equipment is understood as equipment handling continuous bit streams or messages.

The equipment comprises a transmitter and associated encoder and modulator and/or a receiver and associated demodulator and decoder. The encoder and/or decoder may be a separate piece of equipment, in which case this ETS covers the combination of encoder and/or decoder and transmitter and/or receiver equipment.

In this ETS, different requirements are given for the different radio frequency bands, channel separations, environmental conditions and types of equipment, where appropriate.

Access protocols for equipment covered by this ETS are the subject of other ETSI standards.

Additional standards or specifications may be required for equipment such as that intended for connection to the Public Switched Telephone Network (PSTN).

In the cases of:

- combined full bandwidth analogue/full bandwidth digital equipment, if the analogue part of the equipment has already been type approved according to ETS 300 296 [6];
- equipment which has already been type approved according to this ETS, and is resubmitted with an add-on device, using another type of modulation without affecting any other characteristics of the equipment;

only some of the requirements of this ETS apply. These requirements are given in clause 4.

2 Normative references

This ETS incorporates by dated and undated reference, provisions from other publications. These normative references are cited at the appropriate places in the text and the publications are listed hereafter. For dated references, subsequent amendments to, or revisions of any of these publications apply to this ETS only when incorporated in it by amendment or revision. For undated references, the latest edition of the publication referred to applies.

- [1] ETS 300 086: "Radio Equipment and Systems (RES); Land mobile group; Technical characteristics and test conditions for radio equipment with an internal or external RF connector intended primarily for analogue speech".
- [2] I-ETS 300 113 (1992): "Radio Equipment and Systems (RES); Land mobile service; Technical characteristics and test conditions for non-speech and combined analogue speech/non-speech equipment with an internal or external antenna connector, intended for the transmission of data".
- [3] ETR 027: "Radio Equipment and Systems (RES); Methods of measurement for private mobile radio equipment".
- [4] ETR 028: "Radio Equipment and Systems (RES); Uncertainties in the measurement of mobile radio equipment characteristics".
- [5] CCITT Recommendation O.153 (1992): "Basic parameters for the measurement of error performance at bit rates below the primary rate".
- [6] ETS 300 296: "Radio Equipment and Systems (RES); Land mobile service; Technical characteristics and test conditions for radio equipment using integral antennas intended primarily for analogue speech".
- [7] ETS 300 341: "Radio Equipment and Systems (RES); Land mobile service; Technical characteristics and test conditions for radio equipment using an integral antenna transmitting signals to initiate a specific response in the receiver".
- [8] I-ETS 300 230: "Radio Equipment and Systems (RES); Land mobile service; Binary interchange of Information and Signalling (BIIS) at 1 200 bit/s (BIIS 1 200)".
- [9] CEPT Recommendation T/R 71-03: "Procedures for type testing and approval for radio equipment intended for non-public systems".
- [10] prETS 300 113, edition 1 (1995): "Radio Equipment and Systems (RES); Land mobile service; Technical characteristics and test conditions for radio equipment intended for the transmission of data (and speech) and having an antenna connector".

3 Definitions, abbreviations and symbols

3.1 Definitions

For the purposes of this family of ETSs, the following definitions apply. Not all of the terms are used in this particular ETS.

constant envelope angle modulation: Either phase modulation (G3) or frequency modulation (F3).

integral antenna: An antenna designed to be connected to the equipment without the use of a 50 Ω external connector and considered to be part of the equipment. An integral antenna may be fitted internally or externally to the equipment.

Types of measurements:

conducted measurements: Measurements which are made using a direct RF connection to the equipment under test.

radiated measurements: Measurements which involve the absolute measurement of a radiated field.

Types of station:

base station: Equipment fitted with an antenna connector, for use with an external antenna and intended for use in a fixed location.

mobile station: Mobile equipment fitted with an antenna connector, for use with an external antenna, normally used in a vehicle or as a transportable station.

handportable station: Equipment either fitted with an antenna connector or an integral antenna, or both, normally used on a stand-alone basis, to be carried on a person or held in the hand.

Types of tests:

full tests: In all cases except where qualified as "limited", tests are performed according to this ETS.

limited tests: As required by subclause 4.1, the limited tests are as follows:

- transmitter frequency error, subclause 8.1;
- transmitter effective radiated power, subclause 8.2;
- transmitter adjacent channel power, subclause 8.3;
- receiver average usable sensitivity (field strength, data or messages), subclause 9.1;
- receiver adjacent channel selectivity, subclause 9.4.

bit: Binary digit.

block: The smallest quantity of information sent over the radio channel. A constant number of useful bits are always sent together with the corresponding redundancy bits.

packet: One block or a contiguous stream of blocks sent by one (logical) transmitter to one particular receiver or one particular group of receivers.

transmission (physical): One or several packets transmitted between power on and power off of a particular transmitter.

window: A set of inter-related transmissions resulting from the action of the "initiating transmitter", and limited in time by an appropriate access protocol and corresponding occupation rules.

session: A set of inter-related exchanges of packets occupying one or several windows or parts thereof (if applicable). It corresponds to a complete interactive procedure for interchanging data between users, comprising initiation, data transmission and termination procedures. The session can be short (e.g. two packets) or long (e.g. one full page of text).

message: User data to be transferred in one or more packets in a session.

3.2 Abbreviations

For the purposes of this ETS, the following abbreviations apply:

AR1, AR2	categories of Alignment Range as defined in subclause 4.1.3
dBc	dB relative to the carrier power
emf	electro-motive force
FSK	Frequency Shift Keying
FFSK	Fast Frequency Shift Keying
IF	Intermediate Frequency
MSB	Most Significant Bit
RF	Radio Frequency
Rx	Receiver
Tx	Transmitter
VSWR	Voltage Standing Wave Ratio

3.3 Symbols

For the purposes of this ETS, the following symbols apply:

X ₀	Reference field strength (annex A)
R ₀	Reference distance (annex A)
D-M0, D-M1	signals defined in subclause 7.1

The symbols relating to transients and timings are defined in subclause 8.7.1.

4 General

Equipment may be designed to fulfil the requirements of one or more ETSs.

In the case of combined full bandwidth analogue/full bandwidth digital equipment, if the analogue part of the equipment has already been type tested according to ETS 300 296 [6], only some additional measurements have to be performed. They shall ensure that the equipment fulfils the requirements of the following subclauses:

- 5.1.3 (8.3) Adjacent channel power;
- 5.1.4 (8.4) Radiated spurious emissions;
- 5.1.5 (8.5) Transmitter attack time;
- 5.1.6 (8.6) Transmitter release time;
- 5.1.7 (8.7) Transient behaviour of the transmitter;
- 5.2.1 (9.1) Average usable sensitivity (field strength, data or messages);
- 5.2.2 (9.2) Error behaviour at high input levels;
- 5.2.3 (9.3) Co-channel rejection;
- 5.2.4 (9.4) Adjacent channel selectivity.

More precisely, the measurement of radiated spurious emissions in subclause 8.4 should be performed when testing an add-on data unit to an equipment previously type approved to ETS 300 296 [6]. In the case of equipment originally combined for analogue and digital operation, the measurement does not need to be performed when the data-part is active while making the test corresponding to ETS 300 296 [6].

In the case where an equipment has already been type approved according to this ETS, and is resubmitted with an add-on device using another type of modulation without affecting any other characteristics of the equipment, only some additional measurements should be performed. They shall ensure that the equipment fulfils the requirements of the following subclauses:

- 5.1.3 (8.3) Adjacent channel power;
- 5.1.4 (8.4) Radiated spurious emissions;
- 5.1.7 (8.7) Transient behaviour of the transmitter;
- 5.2.1 (9.1) Average usable sensitivity (field strength, data or messages);
- 5.2.2 (9.2) Error behaviour at high input levels;
- 5.2.3 (9.3) Co-channel rejection;
- 5.2.4 (9.4) Adjacent channel selectivity.

The foregoing seven measurements shall be performed on one piece of equipment tuned to a frequency in the centre of the band.

In the case where data is transmitted together with analogue speech, the speech part of the equipment is tested according to ETS 300 296 [6], and it will also be checked that the data does not cause the adjacent channel power and radiated spurious emissions fall outside the appropriate limits.

4.1 Presentation of equipment for testing purposes

Each equipment submitted for type testing shall fulfil the requirements of this ETS on all channels over which it is intended to operate.

To simplify and harmonize the type testing procedures between the different test laboratories, measurements shall be performed, according to this ETS, on samples of equipment defined in subclauses 4.1.1 to 4.1.11. These subclauses are intended to give confidence that the requirements set out in this ETS have been met without the necessity of performing measurements on all channels.

4.1.1 Choice of model for type approval

The manufacturer shall provide one or more production model(s) of the equipment, as appropriate, for type approval testing.

If type approval is given on the basis of tests on a preliminary model, then the corresponding production models shall be identical in all respects with the preliminary model tested.

4.1.2 Definitions of alignment range and switching range

The manufacturer shall, when submitting equipment for type testing, state the alignment ranges for the receiver and the transmitter.

The alignment range is defined as the frequency range over which the receiver and the transmitter can be programmed and/or realigned to operate, without any physical change of components other than programmable read only memories or crystals (for the receiver and the transmitter).

The manufacturer shall also state the switching range of the receiver and the transmitter (which may differ).

The switching range is the maximum frequency range over which the receiver or the transmitter can be operated without reprogramming or realignment. For the purpose of all measurements, the receiver and transmitter shall be considered separately.

4.1.3 Definition of the categories of the alignment range (AR1 and AR2)

The alignment range falls into one of two categories.

The first category corresponds to a limit of the alignment range, of the receiver and the transmitter, which is less than 10 % of the highest frequency of the alignment range for equipment operating on frequencies up to 500 MHz, or less than 5 % for equipment operating above 500 MHz. This category is defined as AR1.

The second category corresponds to an alignment range of the receiver and transmitter which is greater than 10 % of the highest frequency of the alignment range for equipment on frequencies up to 500 MHz, or greater than 5 % for equipment operating above 500 MHz. This category is defined as AR2.

4.1.4 Choice of frequencies

The frequencies for testing shall be chosen by the manufacturer in consultation with the appropriate laboratory, in accordance with subclauses 4.1.5 to 4.1.11 and annex D. The manufacturer when selecting the frequencies for testing shall ensure that the chosen frequencies are within one or more of the national bands for which type approval is required.

4.1.5 Testing of single channel equipment of category AR1

In the case of single channel equipment of the category AR1, one sample of the equipment shall be tested. Full tests shall be carried out on a channel within 100 kHz of the centre frequency of the alignment range.

4.1.6 Testing of single channel equipment of category AR2

In the case of single channel equipment of the category AR2, three samples of the equipment shall be tested. Tests shall be carried out on a total of three channels.

The frequency of the channel of the first sample shall be within 100 kHz of the highest frequency of the alignment range.

The frequency of the channel of the second sample shall be within 100 kHz of the lowest frequency of the alignment range.

The frequency of the channel of the third sample shall be within 100 kHz of the centre frequency of the alignment range.

Full tests shall be carried out on all three channels.

4.1.7 Testing of two channel equipment of category AR1

In the case of two channel equipment of category AR1, one sample of the equipment shall be tested. Tests shall be carried out on the two channels.

The frequency of the upper channel shall be within 100 kHz of the highest frequency of the switching range.

The frequency of the lower channel shall be within 100 kHz of the lowest frequency of the switching range. In addition the average of the frequencies of the two channels shall be within 100 kHz of the centre frequency of the alignment range.

Full tests shall be carried out on the upper channel and limited tests on the lower channel.

4.1.8 Testing of two channel equipment of category AR2

In the case of two channel equipment of the category AR2, three samples of the equipment shall be tested.

Tests shall be carried out on a total of four channels.

The highest frequency of the switching range of one sample shall be within 100 kHz of the centre frequency of the alignment range. The frequency of the upper channel shall be within 100 kHz of the highest frequency of the switching range and the frequency of the lower channel shall be within 100 kHz of the lowest frequency of the switching range.

Full tests shall be carried out on the upper channel and limited tests on the lower channel.

The frequency of one of the channels of the second sample shall be within 100 kHz of the highest frequency of the alignment range.

Full tests shall be carried out on this channel.

The frequency of one of the channels of the third sample shall be within 100 kHz of the lowest frequency of the alignment range.

Full tests shall be carried out on this channel.

4.1.9 Testing of multi channel equipment (more than two channels) of category AR1

In the case of multi channel equipment of the category AR1, one sample of the equipment shall be tested.

The centre frequency of the switching range of the sample shall correspond to the centre frequency of the alignment range.

Full tests shall be carried out on a frequency within 100 kHz of the centre frequency of the switching range. Limited tests shall be carried out within 100 kHz of the lowest and also within 100 kHz of the highest frequency of the switching range.

4.1.10 Testing of multi channel equipment (more than two channels) of category AR2 (switching range less than alignment range)

In the case of multi channel equipment of the category AR2 with switching range less than alignment range, three samples of the equipment shall be tested.

Tests shall be carried out on a total of five channels.

The centre frequency of the switching range of one sample shall be within 100 kHz of the centre frequency of the alignment range. The frequency of the upper channel shall be within 100 kHz of the highest frequency of the switching range and the frequency of the lower channel shall be within 100 kHz of the lowest frequency of the switching range.

Full tests shall be carried out on the centre channel and limited tests on the upper and lower channel.

The frequency of one of the channels of the second sample shall be within 100 kHz of the highest frequency of the alignment range.

Full tests shall be carried out on this channel.

The frequency of one of the channels of the third sample shall be within 100 kHz of the lowest frequency of the alignment range.

Full tests shall be carried out on this channel.

4.1.11 Testing of multi channel equipment (more than two channels) of category AR2 (switching range equals the alignment range)

In the case of multi channel equipment of the category AR2 with switching range equal to alignment range, one sample of the equipment shall be tested.

The centre frequency of the switching range of the sample shall correspond to the centre frequency of the alignment range.

Full tests shall be carried out on a frequency within 100 kHz of the centre frequency of the switching range and within 100 kHz of the lowest and also within 100 kHz of the highest frequency of the switching range.

4.2 Mechanical and electrical design

4.2.1 General

The equipment submitted for type testing by the manufacturer, or his representative, shall be designed, constructed and manufactured in accordance with good engineering practice, and with the aim of minimising harmful interference to other equipment and services.

4.2.2 Controls

Those controls which if maladjusted might increase the interfering potentialities of the equipment shall not be accessible for adjustment by the user.

4.2.3 Transmitter shut-off facility

When a timer for an automatic shut-off facility is operative, at the moment of the time-out the transmitter shall automatically be switched off (the activation of the transmitter key shall reset the timer). A shut-off facility shall be inoperative for the duration of the type test measurements unless it has to remain operative to protect the equipment.

4.2.4 Marking

The marking shall be in accordance with EC Directives and/or CEPT decisions or recommendations as appropriate.

4.3 Testing using bit streams or messages

The manufacturer may elect to have the equipment tested using bit streams or messages. It should be noted that the methods of measurement using messages are usually more time consuming.

4.4 Interpretation of the measurement results

The interpretation of the results recorded in a test report for the measurements described in this ETS shall be as follows:

- a) the measured value related to the corresponding limit shall be used to decide whether an equipment meets the requirements of the ETS;
- b) the actual measurement uncertainty of the test laboratory carrying out the measurements, for each particular measurement shall be included in the test report;
- c) the values of the actual measurement uncertainty shall be, for each measurement, equal to or lower than the figures given in clause 10 (absolute measurement uncertainties).

5 Technical characteristics

This clause contains the limit values of the parameters defined in clauses 8 and 9.

5.1 Transmitter parameter limits

5.1.1 Frequency error

For the definition and the method of measurement, see subclause 8.1.

The frequency error shall not exceed the values given in table 1 under normal, extreme or any intermediate set of conditions.

For practical reasons the measurements shall be performed only under normal and extreme test conditions as stated in subclause 8.1.

Table 1: Frequency error

Channel separation (kHz)	Frequency error limit (kHz)				
	below 47 MHz	47 to 137 MHz	above 137 to 300 MHz	above 300 to 500 MHz	above 500 to 1 000 MHz
20 & 25	± 0,60	± 1,35	± 2,00	± 2,00	± 2,50 (note)
12,5	± 0,60	± 1,00	± 1,50	± 1,50 (note)	No value specified
NOTE: For handportable stations having integral power supplies, these limits only apply to the reduced extreme temperature range 0°C to + 30°C. However for the full extreme temperature conditions (subclause 6.4.1), exceeding the reduced extreme temperature range above, the following frequency error limits apply: <ul style="list-style-type: none"> - ± 2,50 kHz between 300 MHz and 500 MHz; - ± 3,00 kHz between 500 MHz and 1 000 MHz. 					

5.1.2 Effective radiated power

For the definition and the method of measurement, see subclause 8.2.

5.1.2.1 Effective radiated power under normal test conditions

The maximum effective radiated power under normal test conditions shall be within d_f of the rated maximum effective radiated power.

The average effective radiated power under normal test conditions shall be within d_f of the rated average effective radiated power.

The allowance for the characteristics of the equipment ($\pm 1,5$ dB) shall be combined with the actual measurement uncertainty in order to provide d_f , as follows:

$$d_f^2 = d_m^2 + d_e^2;$$

where:

- d_m is the actual measurement uncertainty;
- d_e is the allowance for the equipment ($\pm 1,5$ dB);
- d_f is the final difference.

All values shall be expressed in linear terms.

In all cases the actual measurement uncertainty shall comply with clause 10.

Furthermore, the maximum effective radiated power shall not exceed the maximum value allowed by the administrations.

Example of the calculation of d_f :

$$d_m = 6 \text{ dB (value acceptable, as indicated in the table of maximum uncertainties, table 8);}$$

$$= 3,98 \text{ in linear terms;}$$

$$d_e = 1,5 \text{ dB (fixed value for all equipment fulfilling the requirements of this ETS);}$$

$$= 1,41 \text{ in linear terms;}$$

$$d_f^2 = [3,98]^2 + [1,41]^2;$$

therefore $d_f = 4,22$ in linear terms, or 6,25 dB.

This calculation shows that in this case d_f is in excess of 0,25 dB compared to d_m , the actual measurement uncertainty (6 dB).

5.1.2.2 Effective radiated power under extreme test conditions

The variation of power due to the change of temperature and voltage for the measurements under extreme test conditions shall not exceed + 2 dB or - 3 dB (the measurements shall be performed using the test fixture).

5.1.3 Adjacent channel power

For the definition and the method of measurement, see subclause 8.3.

For channel separations of 20 kHz and 25 kHz, the adjacent channel power shall not exceed a value of 70,0 dB below the carrier power of the transmitter without the need to be below 0,20 mW. For channel separations of 12,5 kHz, the adjacent channel power shall not exceed a value of 60,0 dB below the transmitter carrier power without the need to be below 0,20 mW.

In the case where the equipment is not capable of producing an unmodulated carrier, these measurements shall also be performed under extreme test conditions. Under extreme test conditions, the measured adjacent channel power shall not exceed:

- 65 dB below the carrier for equipment with channel separations of 20 kHz and 25 kHz; and
- 55 dB for channel separations of 12,5 kHz;

without the need to be below 0,20 μ W.

5.1.4 Radiated spurious emissions

For the definition and the method of measurement see subclause 8.4.

The power of any radiated spurious emission shall not exceed the values given in table 2.

Table 2: Radiated spurious emissions

Frequency range	Tx operating	Tx standby
30 MHz to 1 GHz	0,25 μ W (- 36,0 dBm)	2,0 nW (- 57,0 dBm)
above 1 to 12,75 GHz	1,00 μ W (- 30,0 dBm)	20,0 nW (- 47,0 dBm)

5.1.5 Transmitter attack time

For the definition and the method of measurement see subclause 8.5 and figures 9 and 10.

The time t_{am} (measured transmitter attack time) shall not exceed t_{al} (the attack time limit) of 25 ms.

5.1.6 Transmitter release time

For the definition and the method of measurement see subclause 8.6 and figure 11.

The time t_{rm} (measured transmitter release time) shall not exceed t_{rl} (the release time limit) of 20 ms.

5.1.7 Transient behaviour of the transmitter

For the definition and the method of measurement see subclause 8.7 and figures 9, 10 and 11.

5.1.7.1 Time domain analysis of power and frequency

The plots of carrier power and carrier frequency as a function of time, covering in an appropriate way the transients, shall be included in the test report.

At any time when the carrier power is above the steady-state power (P_c) - 30 dB, the carrier frequency shall remain within half a channel separation (df_c) from the steady carrier frequency (F_c).

The slopes of the plots corresponding to both attack and release times, shall be such that:

- $t_p \geq 0,20$ ms and $t_d \geq 0,20$ ms, for attack and release time (subclause 8.7.1);
- between the $P_c - 30$ dB point and the $P_c - 6$ dB point, both in the case of attack and release time, the sign of the slope shall not change.

5.1.7.2 Adjacent channel transient power

The transient power, in the adjacent channels shall not exceed a value of:

- 60,0 dB below the carrier power of the transmitter (dBc) without the need to be below 2 μ W (- 27,0 dBm) for channel separations of 20 and 25 kHz;
- 50,0 dBc without the need to be below 2 μ W (- 27 dBm), for a channel separation of 12,5 kHz.

5.2 Receiver parameter limits

5.2.1 Average usable sensitivity (field strength, data or messages)

For the definitions and the method of measurement, see subclause 9.1.

For the average usable sensitivity limits, four categories of equipment are defined as follows:

- | | |
|-------------|---|
| category A: | equipment having an integral antenna fully within the case; |
| category B: | equipment having an extractable or fixed integral antenna, with an antenna length not exceeding 20 cm external to the case; |
| category C: | equipment having an extractable or fixed integral antenna, with an antenna length exceeding 20 cm external to the case; |
| category D: | equipment not covered by category A, B or C. |

Under normal test conditions for categories A, B and D, the average usable sensitivity shall not exceed the field strength values shown in tables 3(a) and 3(b).

Table 3(a): Sensitivity limits for categories A and D

Frequency band (MHz)	Average usable sensitivity in dB relative to 1 µV/m
30 to 400	27,0
> 400 to 750	28,5
> 750 to 1 000	30,0

Table 3(b): Sensitivity limits for category B

Frequency band (MHz)	Average usable sensitivity in dB relative to 1 µV/m
30 to 130	18,0
> 130 to 300	19,5
> 300 to 440	21,5
> 440 to 600	23,5
> 600 to 800	25,5
> 800 to 1 000	28,0

For category C the following limits shall apply under normal conditions:

- at frequencies greater than 375 MHz the limits shall be as specified in table 3(b);
- at frequencies less than or equal to 375 MHz, a correction factor K shall be subtracted from the specified field strengths in table 3(b). K shall be calculated as:

$$K = 20 \log_{10} \frac{l + 20}{40}$$

where l is the length of the external part of the antenna in cm.

This correction only applies if the antenna length in cm external to the case is less than $(15\,000/f_o - 20)$ in cm, where f_o is the frequency in MHz.

For all categories of equipment, add 6 dB to the limit under normal test conditions to obtain the limit under extreme test conditions.

5.2.2 Error behaviour at high input levels

For the definition and the method of measurement, see subclause 9.2.

The bit error ratio (continuous bit streams) shall not exceed 10^{-4} .

The number of messages not correctly received (lost or corrupted) shall not exceed 1.

5.2.3 Co-channel rejection

For the definition and the method of measurement, see subclause 9.3.

The value of the co-channel rejection ratio, expressed in dB, at any frequency of the unwanted signal within the specified range, shall be between:

- - 8,0 dB and 0 dB for channel separations of 20 kHz and 25 kHz;
- - 12,0 dB and 0 dB for a channel separation of 12,5 kHz.

5.2.4 Adjacent channel selectivity

For the definition and the measurement method, see subclause 9.4.

The adjacent channel selectivity of the equipment shall be such that under the specified test conditions, the given degradation shall not be exceeded for levels of the unwanted signal up to those given in table 4.

Table 4: Adjacent channel selectivity

Channel separation (kHz)	Adjacent channel selectivity limit (dB μ V/m)			
	Unwanted frequencies \leq 68 MHz		Unwanted frequencies $>$ 68 MHz	
	Normal test conditions	Extreme test conditions	Normal test conditions	Extreme test conditions
20 & 25	75	65	$38,3 + 20 \log_{10}(f)$	$28,3 + 20 \log_{10}(f)$
12,5	65	55	$28,3 + 20 \log_{10}(f)$	$18,3 + 20 \log_{10}(f)$

NOTE: f is the value of the carrier frequency expressed in MHz.

5.2.5 Spurious response rejection

For the definition and the measurement method, see subclause 9.5.

The spurious response rejection of the equipment shall be such that under the specified test conditions, the given degradation shall not be exceeded for levels of the unwanted signal up to:

- 75 dB μ V/m for unwanted signal frequencies \leq 68 MHz;
- $(38,3 + 20 \log_{10} f)$ dB μ V/m for unwanted signal frequencies $>$ 68 MHz, where f is the value of the frequency of the carrier expressed in MHz.

5.2.6 Intermodulation response rejection

For the definition and the measurement method, see subclause 9.6.

The intermodulation response rejection of the equipment shall be such that under the specified test conditions, the given degradation shall not be exceeded for levels of the unwanted signal up to:

- 70 dB μ V/m for unwanted frequencies \leq 68 MHz;
- $(33,3 + 20 \log_{10} f)$ dB μ V/m for unwanted frequencies $>$ 68 MHz, where f is the value of the frequency of the carrier expressed in MHz.

5.2.7 Blocking or desensitisation

For the definition and the measurement method, see subclause 9.7.

The blocking level, for any frequency within the specified ranges, shall be:

- \geq 89 dB μ V/m for unwanted frequencies \leq 68 MHz;
- \geq $(52,3 + 20 \log_{10} f)$ dB μ V/m for unwanted frequencies $>$ 68 MHz, where f is the value of the frequency of the carrier expressed in MHz.

5.2.8 Spurious radiations

For the definition and the measurement method, see subclause 9.8.

The power of any spurious radiation shall not exceed the values given in table 5.

Table 5: Radiated components

Frequency range	Limit
30 MHz to 1 GHz	2,0 nW (- 57,0 dBm)
above 1 GHz to 12,75 GHz	20,0 nW (- 47,0 dBm)

6 Test conditions, power sources and ambient temperatures

6.1 Normal and extreme test conditions

Type testing shall be made under normal test conditions, and also, where stated, under extreme test conditions.

6.2 Test power source

During type testing the power source of the equipment shall be replaced by a test power source capable of producing normal and extreme test voltages as specified in subclauses 6.3.2 and 6.4.2. The internal impedance of the test power source shall be low enough for its effect on the test results to be negligible. For the purpose of tests, the voltage of the power source shall be measured at the input terminals of the equipment.

If the equipment is provided with a permanently connected power cable, the test voltage shall be that measured at the point of connection of the power cable to the equipment.

For battery operated equipment the battery shall be removed and the test power source shall be applied as close to the battery terminals as practicable.

During tests the power source voltages shall be maintained within a tolerance of $\pm 1\%$ relative to the voltage at the beginning of each test. The value of this tolerance is critical to power measurements. Using a smaller tolerance provides better measurement uncertainty values.

6.3 Normal test conditions

6.3.1 Normal temperature and humidity

The normal temperature and humidity conditions for tests shall be any convenient combination of temperature and humidity within the following ranges:

- temperature: + 15°C to + 35°C;
- relative humidity: 20 % to 75 %.

When it is impracticable to carry out the tests under these conditions, a note to this effect, stating the ambient temperature and relative humidity during the tests, shall be added to the test report.

6.3.2 Normal test power source

6.3.2.1 Mains voltage

The normal test voltage for equipment to be connected to the mains shall be the nominal mains voltage. For the purpose of this ETS, the nominal voltage shall be the declared voltage or any of the declared voltages for which the equipment was designed.

The frequency of the test power source corresponding to the ac mains shall be between 49 Hz and 51 Hz.

6.3.2.2 Regulated lead-acid battery power sources used on vehicles

When the radio equipment is intended for operation from the usual types of regulated lead-acid battery power source used on vehicles, the normal test voltage shall be 1,1 times the nominal voltage of the battery (6 V, 12 V etc.).

6.3.2.3 Other power sources

For operation from other power sources or types of battery (primary or secondary), the normal test voltage shall be that declared by the equipment manufacturer.

6.4 Extreme test conditions

6.4.1 Extreme temperatures

For tests at extreme temperatures, measurements shall be made in accordance with the procedures specified in subclause 6.5, at the upper and lower temperatures of the following range:

- - 20 °C to + 55 °C.

For the purpose of the note to table 1, subclause 5.1.1 an additional reduced extreme temperature range of 0°C to + 30°C shall be used when the equipment is not able to fulfil the requirements of table 1 over the extreme temperature range of - 20 °C to + 55 °C.

Type test reports shall state the temperature range used.

6.4.2 Extreme test source voltages

6.4.2.1 Mains voltage

The extreme test voltage for equipment to be connected to an ac mains source shall be the nominal mains voltage $\pm 10\%$.

6.4.2.2 Regulated lead-acid battery power sources used on vehicles

When the equipment is intended for operation from the usual types of regulated lead-acid battery power sources used on vehicles the extreme test voltages shall be 1,3 and 0,9 times the nominal voltage of the battery (6 V, 12 V etc.).

6.4.2.3 Power sources using other types of batteries

The lower extreme test voltages for equipment with power sources using the following batteries shall be:

- for the Leclanché or the lithium type of battery: 0,85 times the nominal voltage of the battery;
- for the mercury or nickel-cadmium type of battery: 0,9 times the nominal voltage of the battery.

No upper extreme test voltages apply.

6.4.2.4 Other power sources

For equipment using other power sources, or capable of being operated from a variety of power sources, the extreme test voltages shall be those agreed between the equipment manufacturer and the testing laboratory and shall be recorded in the test report.

6.5 Procedure for tests at extreme temperatures

Before measurements are made the equipment shall have reached thermal balance in the test chamber. The equipment shall be switched off during the temperature stabilising period.

In the case of equipment containing temperature stabilisation circuits designed to operate continuously, the temperature stabilisation circuits may be switched on for 15 minutes after thermal balance has been attained, and the equipment shall then meet the specified requirements. For such equipment the manufacturer shall provide for the power source circuit feeding the crystal oven to be independent of the power source to the rest of the equipment.

If the thermal balance is not checked by measurements, a temperature stabilising period of at least one hour, or a longer period of time as may be decided by the testing laboratory, shall be allowed. The sequence of measurements shall be chosen, and the humidity content in the test chamber shall be controlled so that excessive condensation does not occur.

6.5.1 Procedure for equipment designed for continuous operation

If the manufacturer states that the equipment is designed for continuous operation, the test procedure shall be as follows:

- before tests at the upper extreme temperature the equipment shall be placed in the test chamber and left until thermal balance is attained. The equipment shall then be switched on in the transmit condition for a period of half an hour after which the equipment shall meet the specified requirements;
- before tests at the lower extreme temperature the equipment shall be left in the test chamber until thermal balance is attained, then switched to the standby or receive condition for a period of one minute after which the equipment shall meet the specified requirements.

6.5.2 Procedure for equipment designed for intermittent operation

If the manufacturer states that the equipment is designed for intermittent operation, the test procedure shall be as follows.

- before tests at the upper extreme temperature the equipment shall be placed in the test chamber and left until thermal balance is attained. The equipment shall then be switched on for one minute in the transmit condition, followed by four minutes in the receive condition, after which the equipment shall meet the specified requirements;
- for tests at the lower extreme temperature the equipment shall be left in the test chamber until thermal balance is attained, then switched to the standby or receive condition for one minute after which the equipment shall meet the specified requirements.

7 General conditions

7.1 Normal test signals (wanted and unwanted signals)

The wanted signals for methods of measurement with bit streams and messages are defined in subclauses 7.1.1 and 7.1.2 respectively.

The signal A-M3 is used as an unwanted signal for methods of measurement with either bit streams or messages for measurements such as co-channel rejection (subclauses 5.2.3 and 9.3) and adjacent channel selectivity (subclauses 5.2.4 and 9.4). It shall be as follows:

- signal A-M3, consisting of an RF signal, modulated by an audio frequency signal of 1 kHz with a deviation of 12 % of the channel separation.

Guidance concerning technical characteristics of modulation, coding and format are given in annex E.

7.1.1 Signals for bit stream measurements

When the equipment is designed to transmit continuous bit streams (e.g. data, facsimile, image transmission, digital speech) the normal test signal shall be as follows:

- signal D-M0, consisting of an infinite series of 0-bits;
- signal D-M1, consisting of an infinite series of 1-bits;
- signal D-M2, consisting of a pseudorandom bit sequence of at least 511 bits according to CCITT Recommendation O.153 [5];
- signal D-M2', this is the same type as D-M2, but the pseudorandom bit sequence is independent of D-M2 (perhaps identical with D-M2 but started at a different point of time).

Applying an infinite series of 0 bits or 1 bits does not normally produce the typical bandwidth. Signal D-M2 is designed to produce a good approximation of the typical bandwidth.

7.1.2 Signals for messages

When the equipment is intended to be tested using messages, the normal test signal shall be trains of correctly coded bits or messages.

The normal test signals and modulations shall be obtained as follows:

- signal D-M3, corresponding to single bursts, used for measurements using the up-down method, triggered either manually or by an automatic testing system. This will provide the "normal test signal" as required (e.g. subclause 9.3.3 step d));
- signal D-M4, consisting of correctly coded signals, messages transmitted sequentially, one by one, without gaps between them.

D-M3 is used for receiver methods of measurement with messages where there is a need to transmit single messages a number of times (e.g. 20 times, see "normal test signal" in step e) of subclauses 9.3.3, 9.4.3, 9.5.7, 9.6.3 and 9.7.3). The corresponding normal test modulation shall be agreed between the manufacturer and the test laboratory.

The test signal D-M4 is used for transmitter methods of measurement such as adjacent channel power (subclauses 5.1.3 and 8.3) and radiated spurious emissions (subclauses 5.1.4 and 8.4).

The test signal D-M4 shall be that signal, as agreed between the manufacturer and the test laboratory which produces the greatest radio frequency occupied bandwidth.

The encoder, which is associated with the transmitter, shall be capable of supplying the normal test modulation for D-M3, and the test signal D-M4, which should have continuous modulation for the duration of the measurements, if possible.

Details of D-M3 and D-M4 shall be included in the test report.

7.2 Artificial antenna

Tests on the transmitter requiring the use of the test fixture shall be carried out with a substantially non-reactive non-radiating load of 50 Ω connected to the test fixture terminals.

7.3 Test sites and general arrangements for radiated measurements

For guidance on radiation test sites see annex A. Detailed descriptions of the radiated measurement arrangements are included in this annex. It is common to several (I-)ETSS, in particular covering speech equipment.

7.4 Transmitter automatic shut-off facility

If the equipment is fitted with an automatic transmitter shut-off facility it shall be made inoperative for the duration of the type test unless it has to be left operative to protect the equipment. If the shut off facility is left operative the status of the equipment shall be indicated.

7.5 Modes of operation of the transmitter

For the purpose of the measurements according to this ETS, there should preferably be a facility to operate the transmitter unmodulated. The method of obtaining an unmodulated carrier or special types of modulation patterns may also be decided by agreement between the manufacturer and the testing laboratory. It shall be described in the test report. It may involve suitable temporary internal modifications of the equipment under test. For example, in the case of direct Frequency Shift Keying (FSK), a means to continuously transmit a sequence D-M0 containing only "zeros" and a sequence D-M1 containing only "ones" is desirable.

7.6 Encoder for receiver measurements

Whenever needed and in order to facilitate measurements on the receiver, an encoder for the data system shall accompany the model submitted, together with details of the normal modulation process. The encoder is used to modulate a signal generator for use as a test signal source.

In the case of equipment unable to operate with continuous bit streams, the encoder shall be capable of operation in a repetitive mode, with intervals between each message that are not less than the reset time of the receiver.

Complete details of all codes and code format(s) used shall be given.

7.7 Transceiver data interface

Equipment that does not integrate the keyboard and display used for normal operation shall provide a V.24/V.28 interface (preferably) or other suitable interfaces.

Variation in the level of the input signals, within the specified limits for that interface, shall have no measurable influence on the characteristics of the signals on the radio path.

7.8 Arrangements for test signals at the input of the receiver via a test fixture or a test antenna

Sources of test signals for application to the receiver via a test fixture (clause A.6), a stripline (subclause A.1.3) or a test antenna (clause A.4) shall be connected in such a way that the impedance presented to the test fixture, the stripline or the test antenna is 50 Ω . This requirement shall be met irrespective of whether one or more signals using a combining network are applied to the receiver simultaneously.

The levels of the test signals shall be expressed in terms of the emf at the output of the source prior to connection to the appropriate input connector.

The effects of any intermodulation products and noise produced in the test signal sources shall be negligible.

7.9 Facilities for access

7.9.1 Analogue access

In order to simplify the measurements in subclause 9.5 (spurious response rejection), temporary access to a point where the amplitude of the analogue output of the RF part can be measured should be provided, e.g. Intermediate Frequency (IF) output or the demodulated subcarrier point may be provided for the equipment to be tested. This access can be used to determine or verify the frequency where a spurious response is expected.

7.9.2 Points for bit stream measurement

It is recognised that it is not always possible to measure the air interface bit stream. The manufacturer shall define the points at which the equipment shall be tested in order to make the measurements on bit streams according to clauses 8 and 9.

Figure 1 is presented as an example for clarification only.

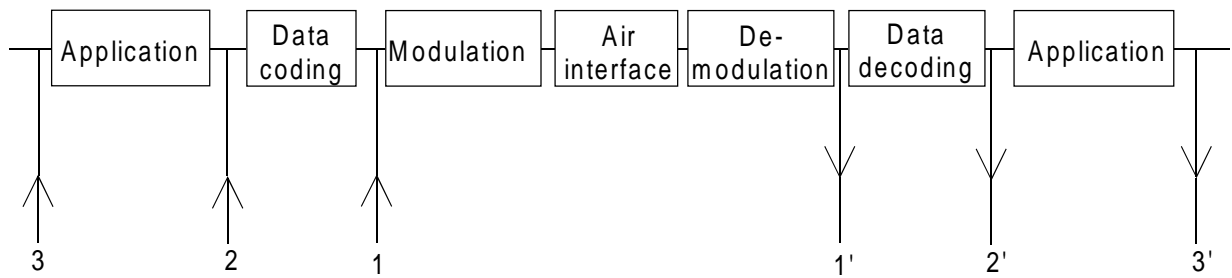

Figure 1: Points for bit stream measurements

It should be noted that the closer the access point is located to the air interface (figure 1), a fewer number of variants may have to be type tested because the measurement is less application dependent.

The tests shall be performed by use of corresponding points (1,1' or 2,2' or 3,3').

The points used shall be recorded in the test report.

7.9.3 Coupling arrangements

Arrangements shall be made by the manufacturer to couple the unit to be tested to the test equipment by a method which does not affect the radiated field (e.g. acoustic, ultra sonic or optic) and according to subclauses 7.9.3.1 and 7.9.3.2.

7.9.3.1 Arrangements for measurements with continuous bit streams

For the measurements of the receiver on a test site, arrangements to couple the unit to be tested to the bit error ratio measuring device shall be available (subclause 7.9.2).

Furthermore, the manufacturer may also provide another facility to give access to the analogue information (subclause 7.9.1).

7.9.3.2 Arrangements for measurements with messages

For the measurements of the receiver on a test site, arrangements to couple the unit to be tested to the bit error observation device (or to an operator) shall be available.

Furthermore, the manufacturer shall also provide another facility to give access to the analogue information (subclause 7.9.1).

7.10 Message received indicator

Any suitable means of indicating that the receiver has successfully received a correctly coded message may be used.

7.11 Reset

The reset may be a manual or preferably automatic method of enabling the receiver to accept a subsequent correctly coded message.

7.12 Reset time

The reset time of the receiver is the minimum time which should elapse between two consecutive messages in order that they may both be successfully received. The reset time shall be declared by the manufacturer so that the normal test signal may have an appropriate format.

7.13 Receiver mute or squelch facility

If the receiver is equipped with a mute or squelch circuit, this shall be made inoperative for the duration of the type tests.

8 Methods of measurement for transmitter parameters

When performing transmitter tests on equipment designed for intermittent operation, the specified maximum transmit time shall not be exceeded.

8.1 Frequency error

This measurement need not be carried out if this parameter has been measured according to the requirements of ETS 300 296 [6].

This measurement is made if the equipment is capable of producing an unmodulated carrier. Otherwise the adjacent channel power shall also be measured under extreme test conditions and the limits given in subclause 5.1.3 shall be met.

8.1.1 Definition

The frequency error of the transmitter is the difference between the measured carrier frequency in the absence of modulation and the nominal frequency of the transmitter.

8.1.2 Method of measurement

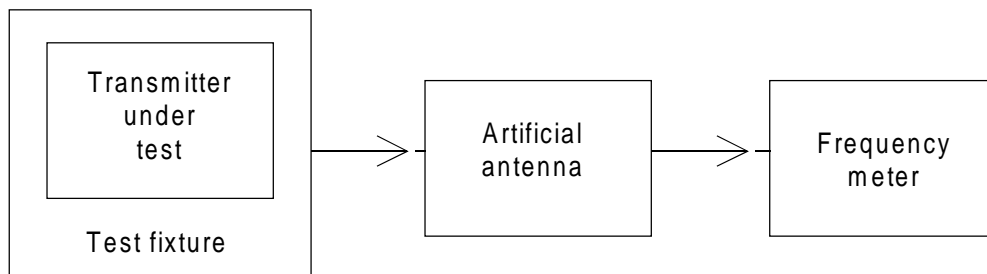

Figure 2: Measurement arrangement

The equipment shall be placed in a test fixture (clause A.6) connected to the artificial antenna (subclause 7.2). The carrier frequency shall be measured in the absence of modulation.

The measurement shall be made under normal test conditions (subclause 6.3) and repeated under extreme test conditions (subclauses 6.4.1 and 6.4.2 applied simultaneously).

8.2 Effective radiated power

This measurement need not be carried out if this parameter has already been measured according to the requirements of ETS 300 296 [6].

Administrations may state the maximum value for the maximum effective radiated power of transmitters; this can be a condition for issuing the licence.

If the equipment is designed to operate with different carrier powers, the rated maximum effective radiated power for each level or range of levels shall be declared by the manufacturer. The power adjustment control shall not be accessible to the user.

The requirements of this ETS shall be met for all power levels at which the transmitter is intended to operate. For practical reasons measurements shall be performed only at the lowest and the highest power level at which the transmitter is intended to operate.

8.2.1 Definition

For the purpose of this measurement, the maximum effective radiated power is defined as the effective radiated power in the direction of maximum field strength under specific conditions of measurement.

The rated maximum effective radiated power is the maximum effective radiated power declared by the manufacturer.

The average effective radiated power is defined as the average of the effective radiated power measured in 8 directions.

The rated average effective radiated power shall also be declared by the manufacturer.

8.2.2 Method of measurement

The measurements shall be made under normal test conditions, subclause 6.3, and extreme test conditions, subclauses 6.4.1 and 6.4.2 applied simultaneously.

8.2.2.1 Maximum effective radiated power under normal test conditions

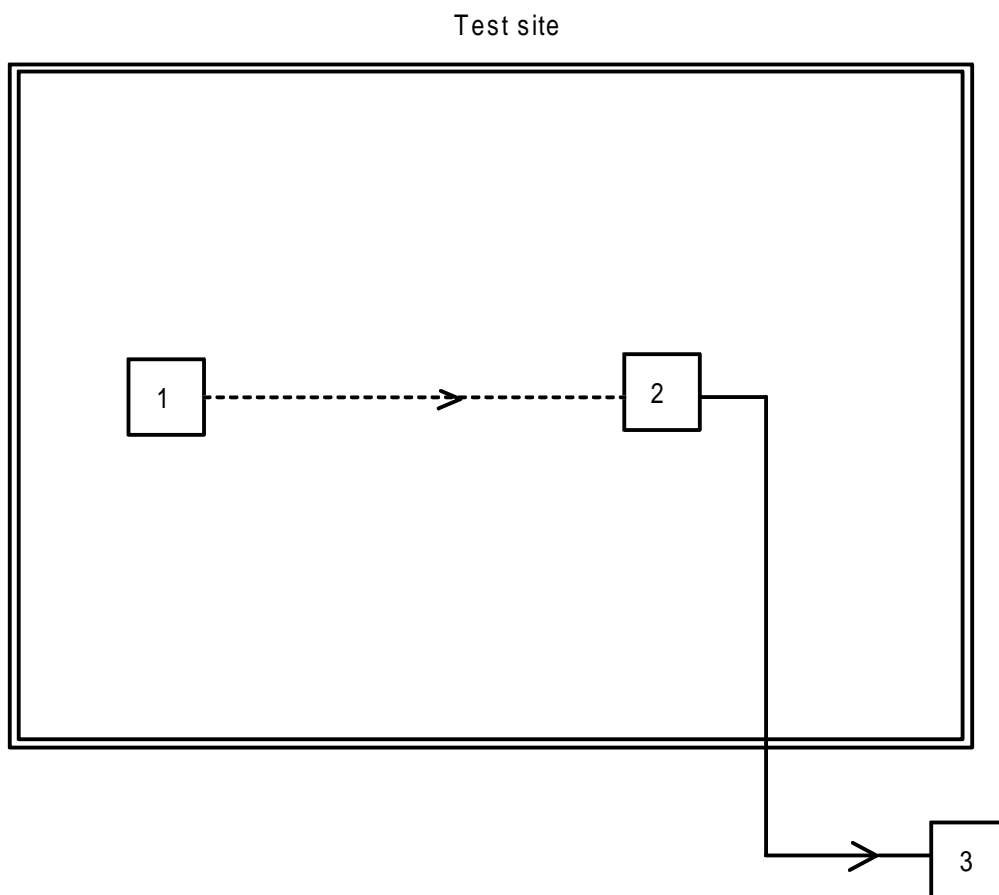

- 1) transmitter under test
- 2) test antenna
- 3) spectrum analyser or selective voltmeter

Figure 3: Measurement arrangement

- a) a test site which fulfils the requirements for the specified frequency range of this measurement shall be used. The test antenna shall be orientated initially for vertical polarisation unless otherwise stated;

The transmitter under test shall be placed on the support in its standard position (clause A.2) and switched on preferably in the absence of modulation. When it is not possible to measure in the absence of modulation, this fact shall be stated in the test report (subclause 7.5).

- b) the spectrum analyser or selective voltmeter shall be tuned to the transmitter carrier frequency. The test antenna shall be raised or lowered through the specified height range until the maximum signal level is detected on the spectrum analyser or selective voltmeter;
- c) the transmitter shall be rotated through 360° around a vertical axis until a higher or the "highest" maximum signal is received;

- d) the test antenna shall be raised or lowered again through the specified height range until a maximum is obtained. This level shall be recorded. (This maximum may be a lower value than the value obtainable at heights outside the specified limits);

The test antenna may not need to be raised or lowered if the measurement is carried out on a test site according to subclause A.1.2.

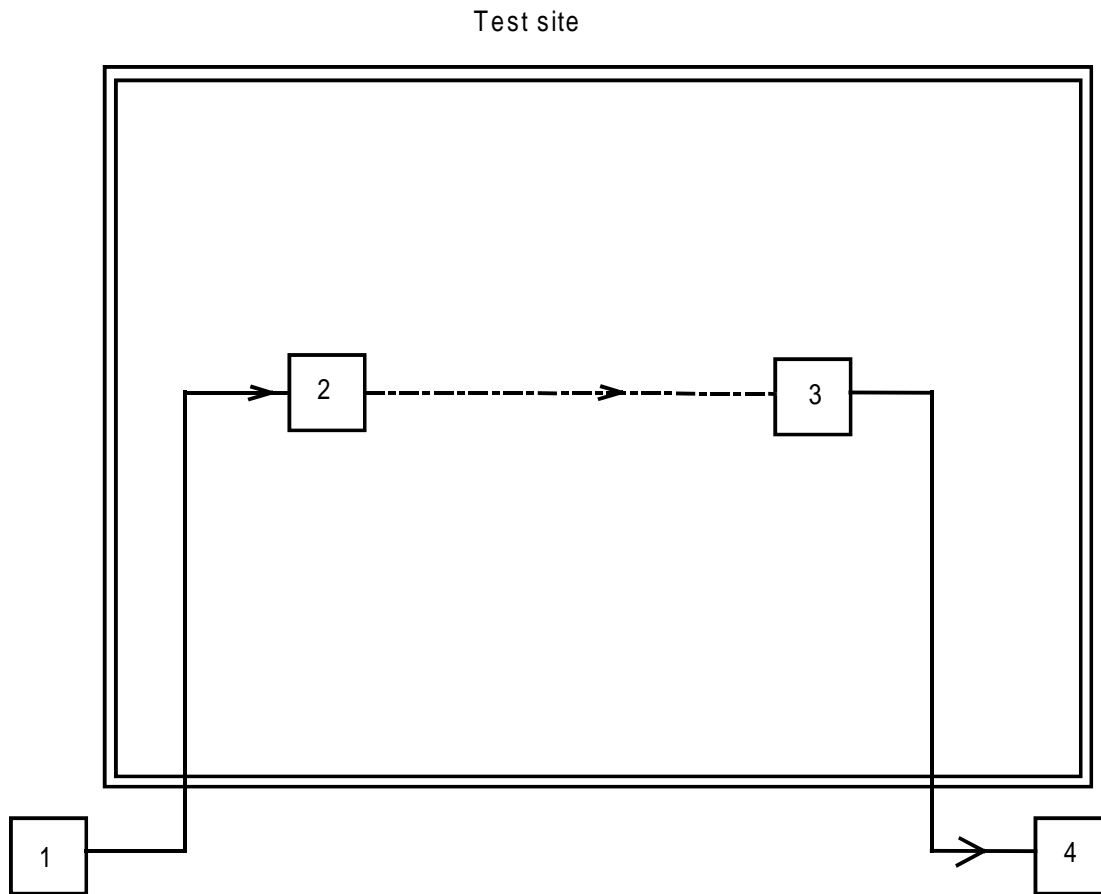

- 1) signal generator
- 2) substitution antenna
- 3) test antenna
- 4) spectrum analyser or selective voltmeter

Figure 4: Measurement arrangement

- e) using measurement arrangement of figure 4 the substitution antenna shall replace the transmitter antenna in the same position and in vertical polarisation. The frequency of the signal generator shall be adjusted to the transmitter carrier frequency. The test antenna shall be raised or lowered as necessary to ensure that the maximum signal is still received;

The test antenna may not need to be raised or lowered if the measurement is carried out on a test site according to subclause A.1.2.

The input signal to the substitution antenna shall be adjusted in level until an equal or a known related level to that detected from the transmitter is obtained in the test receiver.

The value of the maximum effective radiated power of the equipment under test is equal to the power supplied by the signal generator, increased by the known relationship if necessary and after corrections due to the gain of the substitution antenna and the cable loss between the signal generator and the substitution antenna.

- f) steps b) to e) above shall be repeated with the test antenna and the substitution antenna orientated for horizontal polarisation;

- g) the maximum effective radiated power of the equipment under test shall be expressed as the higher of the two values found in step e).

8.2.2.2 Average effective radiated power under normal test conditions

- a) the procedures in steps b) to e) described in subclause 8.2.2.1 shall be repeated, except that in step c) the transmitter shall be rotated through 8 positions, 45° apart, starting at the position corresponding to maximum effective radiated power (subclause 8.2.2.1 step g));
- b) the average effective radiated power corresponding to the eight measured values is given by:

$$\text{average radiated power} = \frac{\sum_{i=1}^8 P_i}{8}$$

where P_i is the power corresponding to each position.

8.2.2.3 Method of measurements of maximum and average effective radiated power under extreme test conditions

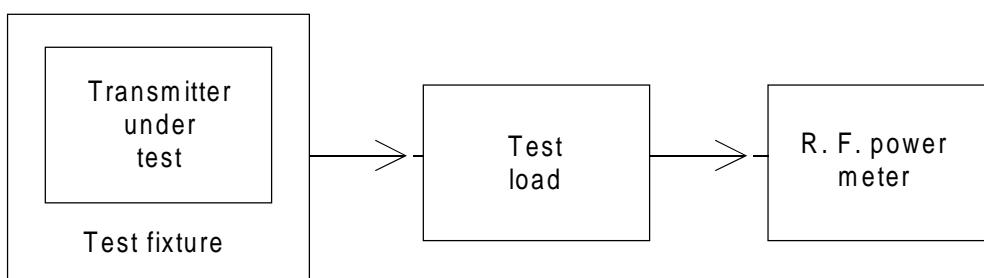

Figure 5: Measurement arrangement

- a) the measurement shall also be performed under extreme test conditions. Due to the impossibility of repeating the above measurement on a test site under extreme temperature conditions, only a relative measurement is performed, using the test fixture (clause A.6) and the measurement arrangement of figure 5;
- b) the power delivered to the test load is measured under normal and extreme test conditions, and the difference in dB is recorded. This difference is algebraically added to the average effective radiated power under normal test conditions, in order to obtain the average effective radiated power under extreme test conditions;
- c) a similar calculation will provide the maximum effective radiated power;
- d) additional uncertainties can occur under extreme test conditions due to the calibration of the test fixture.

8.3 Adjacent channel power

This measurement shall be carried out even if the equipment has been tested to the requirements of ETS 300 296 [6].

8.3.1 Definition

The adjacent channel power is that part of the total power output of a transmitter under defined conditions of modulation, which falls within a specified passband centred on the nominal frequency of either of the adjacent channels. This power is the sum of the mean power produced by the modulation, hum and noise of the transmitter.

It is specified either as the ratio expressed in decibels of the carrier power to the adjacent channel power or as the absolute value of the power in the adjacent channel.

8.3.2 Method of measurement

The adjacent channel power may be measured with a power measuring receiver which conforms with the requirements given in annex B.

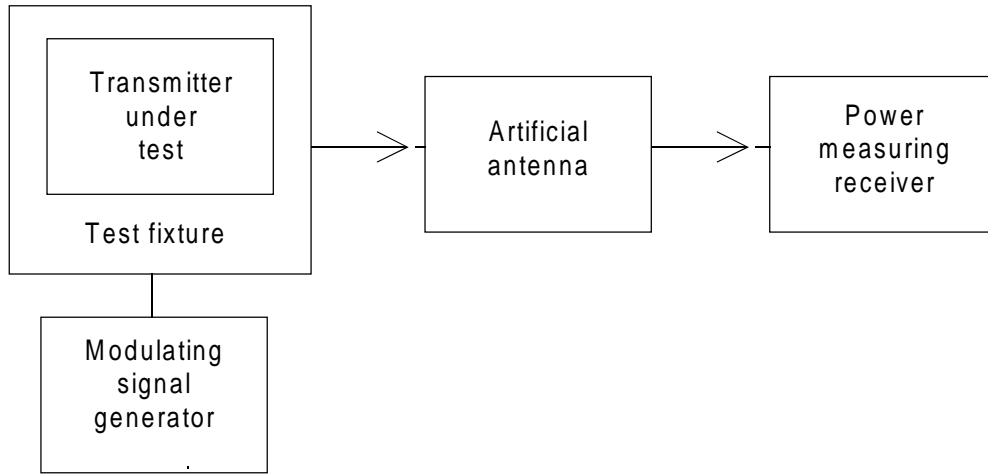

Figure 6: Measurement arrangement

- a) the transmitter under test shall be placed in the test fixture (clause A.6) connected via the artificial antenna (subclause 7.2) to a power measuring receiver calibrated to measure rms power level. The level at the receiver input shall be within its allowed limit. The transmitter shall be operated at the maximum carrier power level available;
- b) with the transmitter unmodulated, the tuning of the power measuring receiver shall be adjusted so that a maximum response is obtained. This is the 0 dB response point. The power measuring receiver attenuator setting and the reading of the meter shall be recorded;
- c) the tuning of the power measuring receiver shall be adjusted away from the carrier so that its - 6 dB response nearest to the transmitter carrier frequency is located at a displacement from the nominal frequency of the carrier as given in table 6;

Table 6: Frequency displacement

Channel separation (kHz)	Displacement (kHz)
12,5	8,25
20	13
25	17

The same result may be obtained by tuning the power measuring receiver (point D2 in figure B.2) to the nominal frequency of the adjacent channel, if it has been suitably calibrated.

- d) the transmitter shall be modulated by the test signal D-M2 or D-M4 as appropriate (subclause 7.1);
- e) the power measuring receiver variable attenuator shall be adjusted to obtain the same meter reading as in step b) or a known relation to it. This value shall be recorded;
- f) the ratio of adjacent channel power to carrier power is the difference between the attenuator settings in step b) and e), corrected for any differences in the reading of the meter. Alternatively the absolute value of the adjacent channel power may be calculated from the above ratio and the transmitter carrier power;
- g) steps c) to f) shall be repeated with the power measuring receiver tuned to the other side of the carrier;
- h) for the purpose of equipment which is not capable of producing an unmodulated carrier (subclause 8.1), the measurement shall be repeated under extreme test conditions (subclauses 6.4.1 and 6.4.2 applied simultaneously).

8.4 Radiated spurious emissions

This measurement need not be carried out on equipment which is simultaneously submitted for approval to the requirements of ETS 300 296 [6] and of this ETS, if the data part is operational while making the corresponding test in ETS 300 296 [6].

8.4.1 Definition

Spurious emissions are emissions at frequencies, other than those of the carrier and sidebands associated with normal modulation, radiated by the antenna and by the cabinet of the transmitter.

They are specified as the radiated power of any discrete signal.

8.4.2 Method of measurement

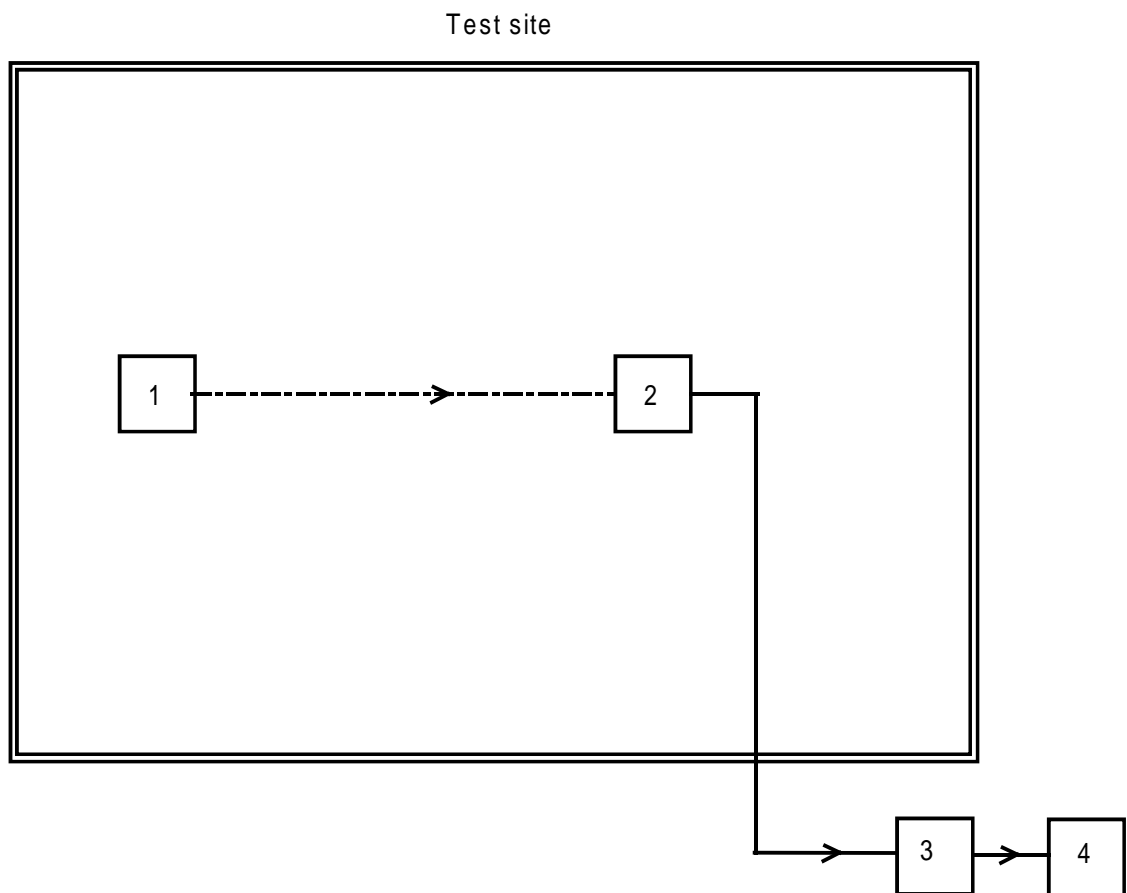

- 1) transmitter under test
- 2) test antenna
- 3) high 'Q' (notch) or high pass filter
- 4) spectrum analyser or selective voltmeter

Figure 7: Measurement arrangement

- a) a test site which fulfils the requirements of the specified frequency range of this measurement shall be used. The test antenna shall be orientated initially for vertical polarisation and connected to a spectrum analyser or a selective voltmeter, through a suitable filter to avoid overloading of the spectrum analyser or selective voltmeter. The bandwidth of the spectrum analyser or selective voltmeter shall be between 10 kHz and 100 kHz, set to a suitable value to correctly perform the measurement;

For the measurement of spurious emissions below the second harmonic of the carrier frequency the filter used shall be a high "Q" (notch) filter centred on the transmitter carrier frequency and attenuating this signal by at least 30 dB.

For the measurement of spurious emissions at and above the second harmonic of the carrier frequency the filter used shall be a high pass filter with a stop band rejection exceeding 40 dB. The cut-off frequency of the high pass filter shall be approximately 1,5 times the transmitter carrier frequency.

The transmitter under test shall be placed on the support in its standard position (clause A.2) and shall be switched on without modulation.

If an unmodulated carrier cannot be obtained then the measurements shall be made with the transmitter modulated by the test signal D-M2 or D-M4 as appropriate (subclause 7.1) in which case this fact shall be recorded in the test report.

- b) the radiation of any spurious emission shall be detected by the test antenna and spectrum analyser or selective voltmeter over the frequency range 30 MHz to 4 GHz, except for the channel on which the transmitter is intended to operate and its adjacent channels. In addition, for equipment operating on frequencies above 470 MHz, measurements shall be repeated over the frequency range 4 GHz to 12,75 GHz. The frequency of each spurious emission detected shall be recorded. If the test site is disturbed by interference coming from outside, this qualitative search may be performed in a screened room, with a reduced distance between the transmitter and the test antenna;
- c) at each frequency at which an emission has been detected, the spectrum analyser or selective voltmeter shall be tuned and the test antenna shall be raised or lowered through the specified height range until the maximum signal level is detected on the spectrum analyser or selective voltmeter;
- d) the transmitter shall be rotated through 360° around a vertical axis, until a higher maximum signal is received;
- e) the test antenna shall be raised or lowered again through the specified height range until a maximum is obtained. This signal level shall be recorded;

The test antenna may not need to be raised or lowered if the measurement is carried out on a test site according to subclause A.1.2.

Test site

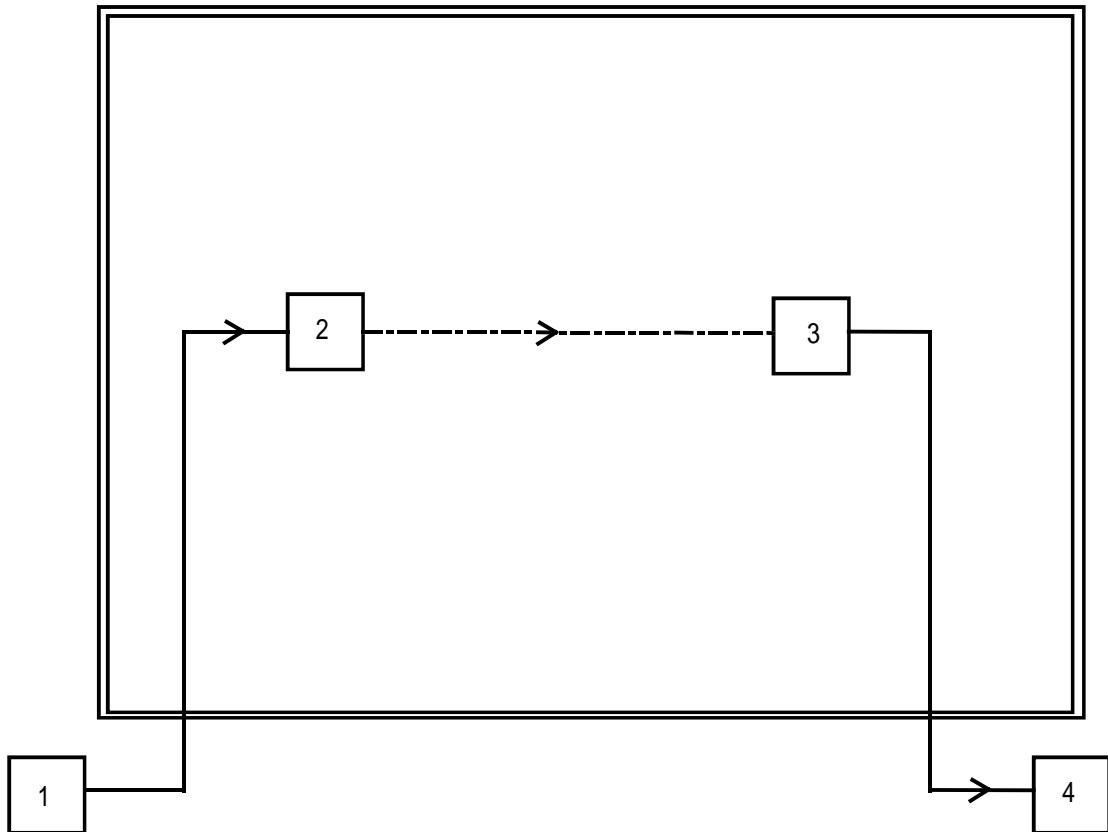

- 1) signal generator
- 2) substitution antenna
- 3) test antenna
- 4) spectrum analyser or selective voltmeter

Figure 8: Measurement arrangement

- f) using the measurement arrangement of figure 8, the substitution antenna shall replace the transmitter antenna in the same position and in vertical polarisation. It shall be connected to the signal generator;
- g) at each frequency at which an emission has been detected, the signal generator, substitution antenna and spectrum analyser or selective voltmeter shall be tuned to the emission frequency. The test antenna shall be raised or lowered through the height range until the maximum signal level is detected on the spectrum analyser or selective voltmeter;

The test antenna may not need to be raised or lowered if the measurement is carried out on a test site according to subclause A.2.1.

The level of the signal generator giving the same signal level on the spectrum analyser or selective voltmeter as in item e) above shall be recorded. This value, after corrections due to the gain of the substitution antenna and the cable loss between the signal generator and the substitution antenna, is the radiated spurious emission at this frequency.

The resolution bandwidth of the measuring instrument shall be the smallest bandwidth available which is greater than the spectral width of the spurious component being measured.

- h) steps c) to g) above shall be repeated with the test antenna orientated for horizontal polarisation;
- j) steps c) to h) above shall be repeated with the transmitter in stand-by condition if this option is available.

8.5 Transmitter attack time

This measurement does not apply to transmitters intended for continuous transmission only.

8.5.1 Definition

The transmitter attack time (t_a) is the time which elapses between the initiation of the "transmitter on" function (T_{xon}) and:

- a) the moment when the transmitter output power has reached a level 1 dB below or 1,5 dB above the steady state power (P_c) and maintains a level within + 1,5 dB/- 1 dB from P_c thereafter as seen on the measuring equipment or in the power plot as a function of time; or
- b) the moment after which the frequency of the carrier always remains within ± 1 kHz of its steady state frequency (F_c) as seen on the measuring equipment or the frequency plot as a function of time;

whichever occurs later (subclause 8.7.2, figures 9 and 10).

The measured value of t_a is t_{am} ; its limit is t_{al} .

The choice of conditions for b), above, is made in order to make the method of measurement easier to perform and to have good repeatability. Normally under these conditions, the frequency of the carrier will be within the frequency tolerance of the steady state (df_e), a few ms after the end of the attack time as defined in b) above.

8.5.2 Method of measurement

The measurement procedure shall be as follows:

- a) the transmitter under test shall be placed in the test fixture connected to a RF detector and to a test discriminator via a matched test load. The attenuation of the test load shall be chosen in such a way that the input of the test discriminator is protected against overload and the limiter amplifier of the test discriminator operates correctly in the limiting range as soon as the transmitter carrier power (before attenuation) exceeds 1 mW;

A dual trace storage oscilloscope (or a transient recorder) records the amplitude transient from the detector on a logarithmic scale and the frequency transient from the discriminator.

A trigger device may be required to ensure that the start of the sweep of the oscilloscope timebase occurs the instant at which the "transmitter on" function is initiated.

The measuring arrangement is shown in figure 12 of subclause 8.7.3.2.

A spectrum analyser and a test discriminator/storage oscilloscope can also be used.

- b) the traces of the oscilloscope shall be calibrated in power and frequency (y-axis) and in time (x-axis), using the signal generator;
- c) the transmitter attack time shall be measured by direct reading on the oscilloscope while the transmitter is preferably unmodulated.

8.6 Transmitter release time

This measurement does not apply to transmitters intended for continuous transmission only.

8.6.1 Definition

The transmitter release time (t_r) is the time which elapses between the initiation of the "transmitter off" function (T_{xoff}) and the moment when the transmitter output power has reduced to a level 50 dB below the steady state power (P_c) and remains below this level thereafter as seen on the measuring equipment or in the power plot as a function of time (subclause 8.7.2, figure 11).

The measured value of t_r is t_{rm} ; its limit is t_{rl} .

8.6.2 Method of measurement

The measurement procedure shall be as follows:

- a) the transmitter under test shall be placed in the test fixture connected to a RF detector and to a test discriminator via a matched test load. The attenuation of the test load shall be chosen in such a way that the input of the test discriminator is protected against overload and the limiter amplifier of the test discriminator operates correctly in the limiting range as long as the transmitter carrier power (before attenuation) exceeds 1 mW;

A dual trace storage oscilloscope (or a transient recorder) records the amplitude transient from the detector on a logarithmic scale and the frequency transient from the discriminator. A trigger device may be required to ensure that the start of the sweep of the oscilloscope timebase occurs the instant at which the "transmitter off" function is initiated. If the transmitter possesses an automatic powering down facility (e.g. in the case of fixed length message transmission), it may replace the trigger device for starting the sweep of the oscilloscope.

The measuring arrangement is shown in figure 12 of subclause 8.7.3.2.

A spectrum analyser and a test discriminator/storage oscilloscope can also be used as shown in figure 12.

- b) the traces of the oscilloscope shall be calibrated in power and frequency (y-axis) and in time (x-axis) by replacing the transmitter and test load by the signal generator;
- c) the transmitter release time shall be measured by direct reading on the oscilloscope while the transmitter is preferably unmodulated.

8.7 Transient behaviour of the transmitter

Limitations of the transmitter attack and release times (subclauses 8.5 and 8.6) are intended to improve the spectrum efficiency. The attack and release times can also be used to allow the definition of the timings in the protocols.

The measurements of transient behaviour are intended to ensure that the transmitter will not cause harmful interference in the other channels when the operating frequency is outside the tolerance of the steady state (df_e).

The method of measurement results in particular in:

- the drawing of plots of "carrier power as a function of time" and "carrier frequency as a function of time";
- the evaluation of the slopes of those plots between predetermined points;
- the measurement of the transient power in the adjacent channels.

8.7.1 Definitions

The transient behaviour of the transmitter is defined as the time-dependency of transmitter frequency, power and adjacent channel transmitter power when the RF output power is switched on and off.

The following powers, frequencies, frequency tolerances and transient times are specified:

- P_o rated power;
- P_c steady state power;
- P_a adjacent channel transient power. This is the transient power falling into the adjacent channels due to switching the transmitter on and off (subclause 8.7.3.3);

- F_o nominal carrier frequency;
- F_c steady state carrier frequency;
- df frequency difference (relative to F_c) or frequency error (absolute) (subclause 8.1.1) of the transmitter;
- df_e limit of the frequency error (df) in the steady state (subclause 5.1.1);
- df_0 limit of the frequency difference (df) equal to 1 kHz; if it is impossible to switch off the transmitter modulation one half channel separation is added;
- df_c limit of the frequency difference (df) during the transient, equal to one half channel separation; while the frequency difference is less than df_c , the carrier frequency remains within the boundaries of the allocated channel; if it is impossible to switch off the transmitter modulation another half channel separation is added;
- T_{xon} time at which the final irrevocable logic decision to power on the transmitter is taken. If an access point is unavailable then the time after which the carrier power exceeds ($P_c - 50$ dB) may be taken. This fact shall be recorded in the test report;

The power starts to rise somewhere between T_{xon} and t_{on} (RF-power on).

- t_{on} time when the carrier power, exceeds $P_c - 30$ dB;
- t_p period of time starting at t_{on} and finishing when the power reaches $P_c - 6$ dB;
- t_{am} transmitter attack time as defined in subclause 8.5;
- t_{al} limit of t_{am} as given in subclause 5.1.5;
- T_{xoff} time at which the final irrevocable logic decision to power off the transmitter is taken. If an access point is unavailable then the time after which the carrier power remains below ($P_c - 3$ dB) may be taken. This fact shall be recorded in the test report;

The power starts to decrease somewhere between T_{xoff} and the moment when $P_c - 6$ dB is reached (RF-power off).

- t_{off} time when the carrier power falls below $P_c - 30$ dB;
- t_d period of time starting when the power falls below $P_c - 6$ dB and finishing at t_{off} ;
- t_{rm} transmitter release time as defined in subclause 8.6, after which the power remains below $P_c - 50$ dB;
- t_{rl} limit of t_{rm} as given in subclause 5.1.6.

If use is made of a synthesizer and/or a PLL system, for determining the transmitter frequency, then the transmitter shall be inhibited when synchronisation is absent or in the case of PLL, when the loop system is not locked.

8.7.2 Timings, frequencies and powers

Figures 9, 10 and 11 represent the timings, frequencies and powers as defined in subclauses 8.5.1, 8.6.1 and 8.7.1.

The corresponding limits are given in subclauses 5.1.5, 5.1.6 and 5.1.7.

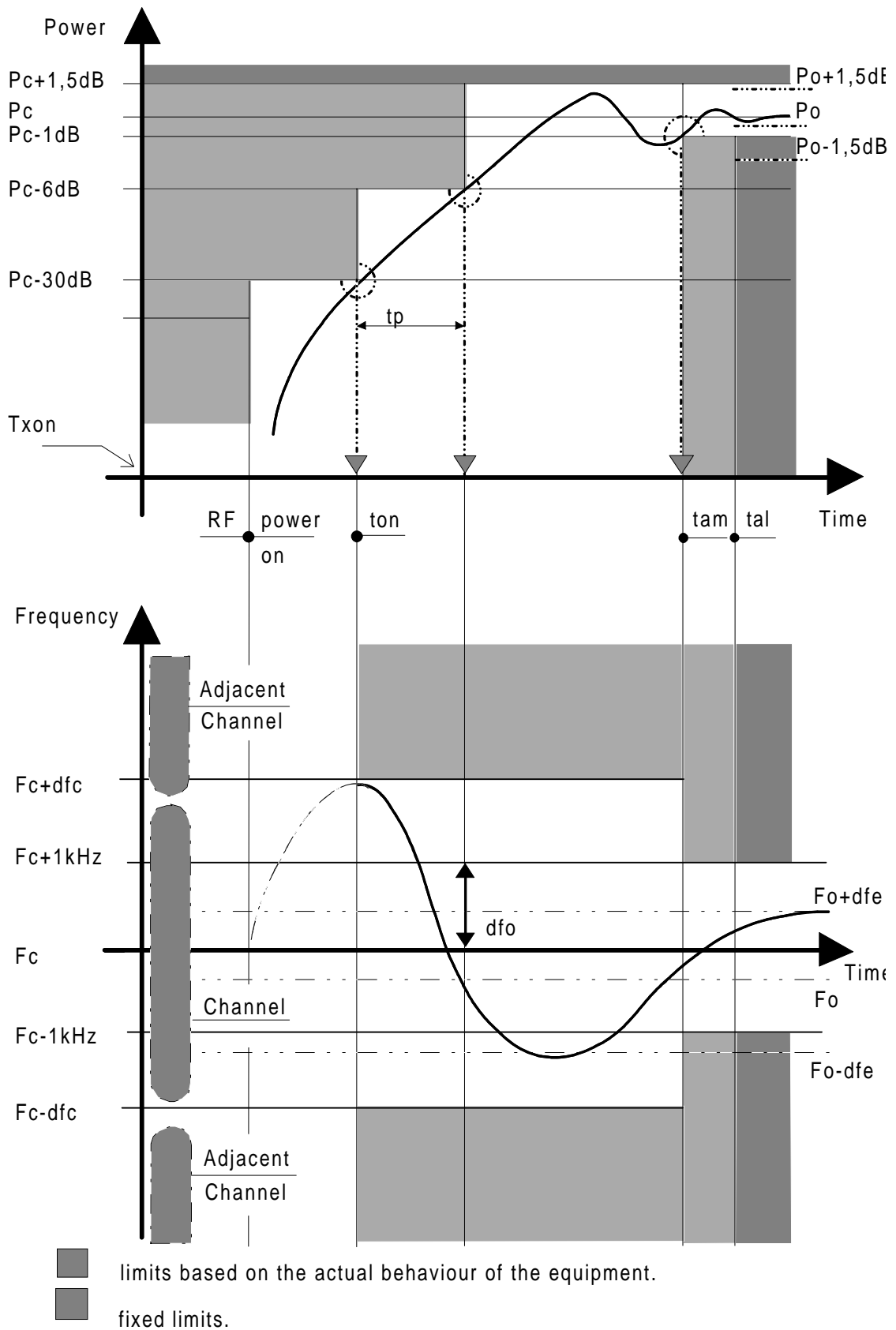

Figure 9: Transmitter attack time according to 8.5.1 a) and transient behaviour during switch-on (Case where the attack time is given by the behaviour of the power rise)

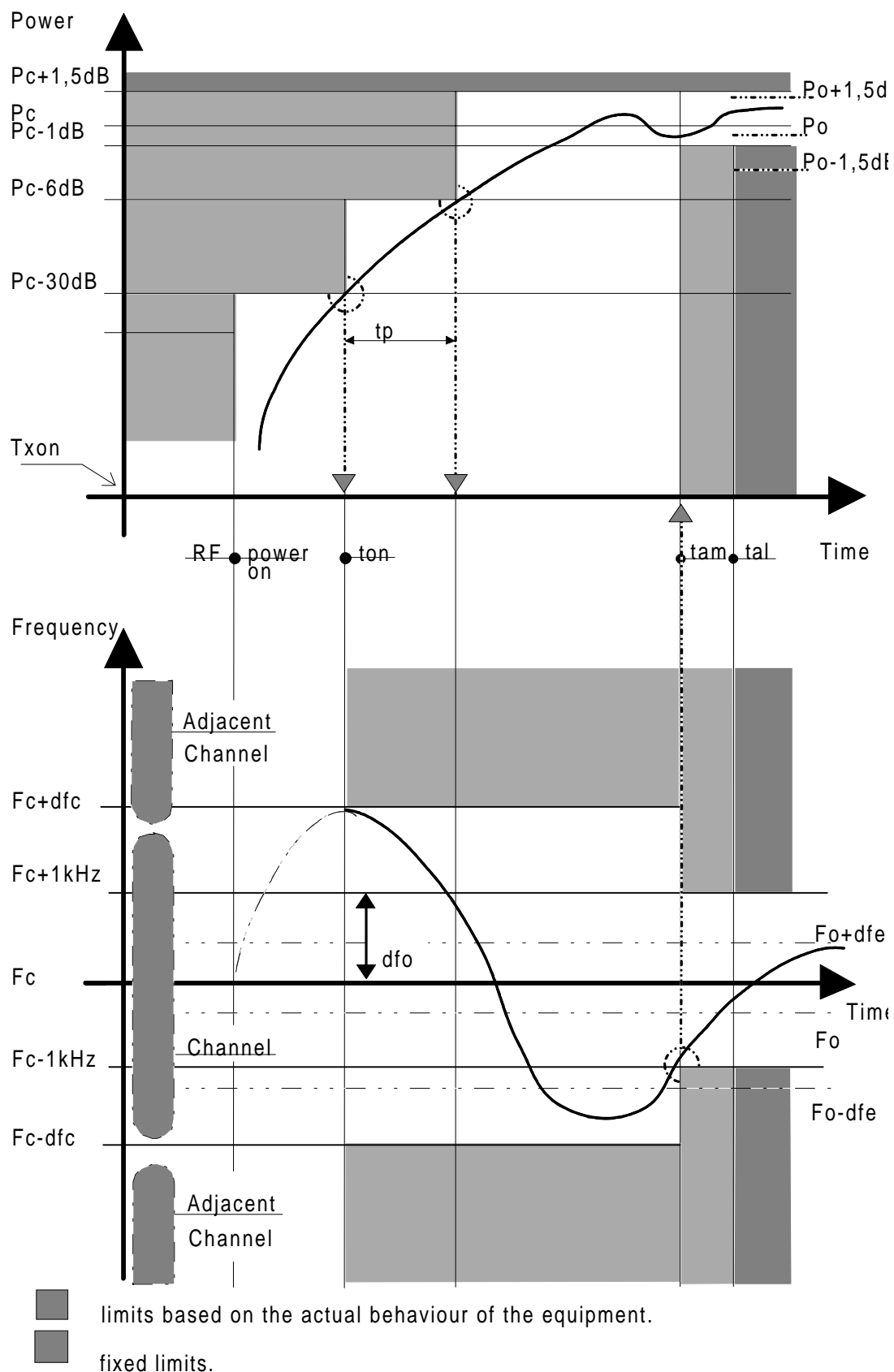

Figure 10: Transmitter attack time according to 8.5.1 b) and transient behaviour during switch-on (Case where the attack time is given by the behaviour of the frequency)

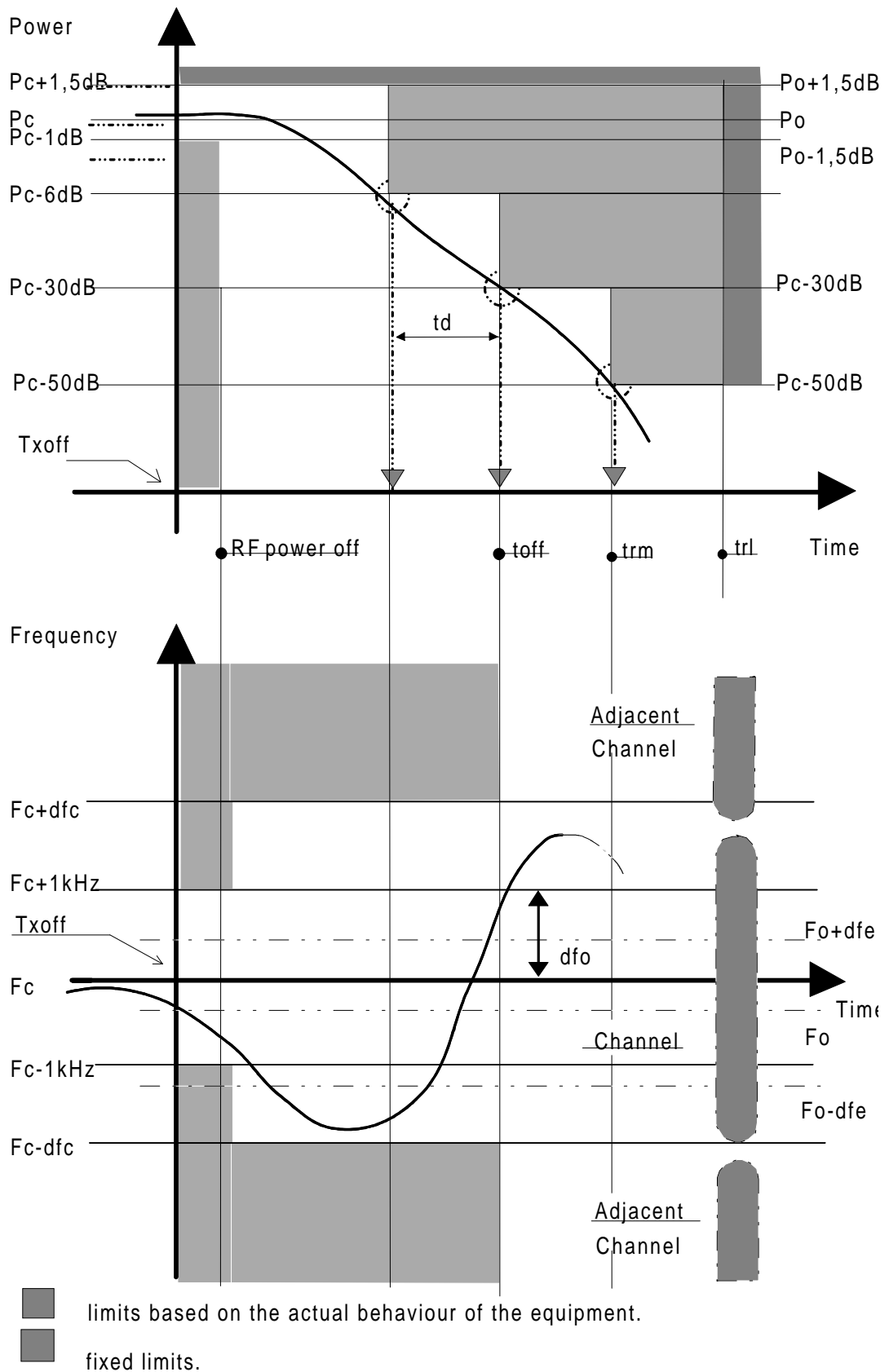

Figure 11: Transmitter release time according to subclause 8.6.1 and transient behaviour, during switch-off

8.7.3 Methods of measurement

The transmitter shall be placed in the test fixture (clause A.6).

The transient timings (switch on/switch off) and the frequency differences occurring during these periods of time can be measured by means of a spectrum analyser and a test discriminator which meets the requirements indicated in subclause 8.7.3.2. The corresponding limits are given in subclause 5.1.7.

The power impairing the operation on the adjacent channels can be measured using an appropriate transient power measuring device which meets the requirements of subclause 8.7.3.4.

8.7.3.1 Time and frequency domain analysis measurements

The measurement shall be performed with the transmitter unmodulated if possible. If the transmitter cannot be operated unmodulated, the measurement shall be performed with modulation and this fact shall be recorded in the test report.

The transmitter under test shall be placed in the test fixture and connected to the test set-up as shown in figure 12.

The calibration of the test set-up shall be checked. The output of the test fixture shall be connected to the input of the spectrum analyser and test discriminator via a power splitter and attenuator(s).

The attenuation of the power attenuators shall be chosen in such a way that the input of the test equipment is protected against overload and that the limiter amplifier of the test discriminator operates correctly in the limiting range when the power conditions of subclause 8.7.1 are reached.

The spectrum analyser is set to measure and display power as a function of time ("zero span mode").

The test discriminator shall be calibrated. This may be carried out by feeding RF voltages from a signal generator with defined frequency differences from the nominal frequency of the transmitter.

By appropriate means, a triggering pulse is generated for the test equipment when the T_{xon} function or the T_{xoff} function are activated.

The "RF power on" and the "RF power off" can be monitored.

The voltage occurring at the test discriminator output shall be recorded as a function of time in correspondence with the power level on a storage device or a transient recorder. This voltage is a measure of the frequency difference. The elapsed periods of time during the frequency transient can be measured using the time base of the storage device. The output of the test discriminator is valid only after t_{on} and before t_{off} .

8.7.3.2 Test arrangement and characteristics of the test discriminator

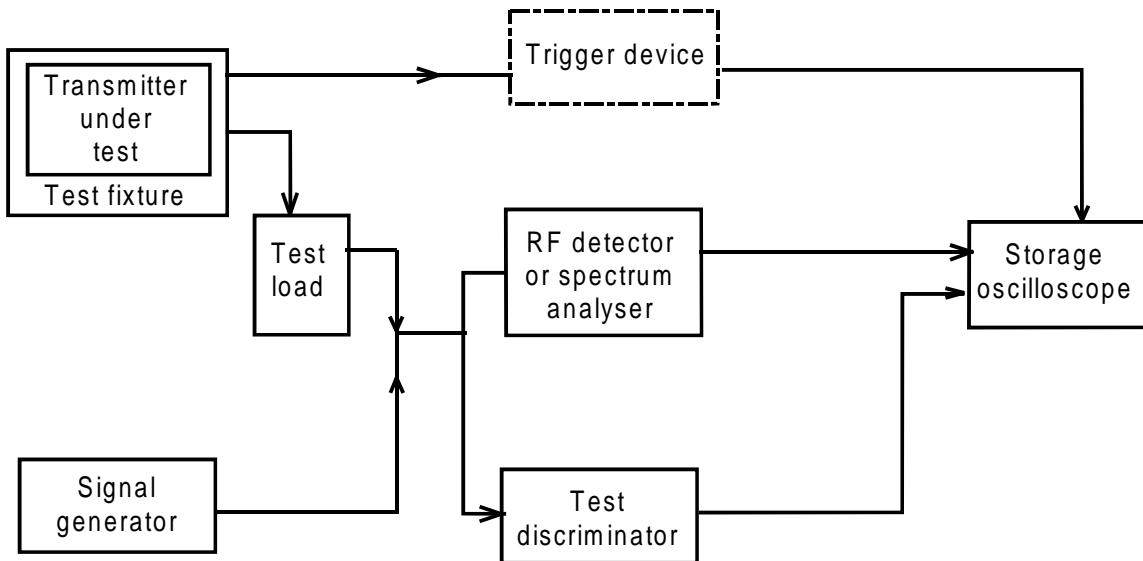

Figure 12: Test arrangement for transient behaviour of transmitter power and frequency, including transmitter attack and release time

The test discriminator may consist of a mixer and a local oscillator (providing the auxiliary frequency) used to convert the transmitter frequency to be measured into the frequency fed to the (broadband) limiter amplifier and the associated broadband discriminator:

- the test discriminator shall be sensitive enough to measure input signals down to $P_c - 30$ dB;
- the test discriminator shall be fast enough to display the frequency deviations (approximately 100 kHz/100 μ s);
- the test discriminator output shall be dc coupled.

8.7.3.3 Adjacent channel transient power measurements

The transmitter under test shall be placed in the test fixture (clause A.6) and connected via the power attenuator to the "adjacent channel transient power measuring device" as described in subclause 8.7.3.4., so that the level at its input shall be between zero and - 10 dBm when the transmitter power is P_c .

- a) the transmitter shall preferably be unmodulated and operated at the maximum power level available under normal test conditions. If an unmodulated carrier cannot be obtained this fact shall be recorded in the test report;
- b) the tuning of the "transient power measuring device" shall be adjusted so that a maximum response is obtained. This is the 0 dBc reference level;
- c) the tuning of the "transient power measuring device" shall be adjusted away from the carrier so that its - 6 dB response nearest to the transmitter carrier frequency is located at a displacement from the nominal carrier frequency as given in table 7;

Table 7: Frequency displacement

Channel separation (kHz)	Displacement (kHz)
12,5	8,25
20	13
25	17

- d) the transmitter shall be switched on;
- e) the spectrum analyser shall be used to record the first 35 ms of the envelope of the transient power as a function of time. The peak envelope transient power shall be recorded in dBc;
- f) the transmitter shall be switched off;
- g) the spectrum analyser shall be used to record the first 35 ms of the envelope of the transient power as a function of time. The peak envelope transient power shall be recorded in dBc;
- h) steps c) to g) shall be repeated with the "transient power measuring device" tuned to the other side of the carrier;
- j) the transient power in the adjacent channel during the attack and release times is the dBc value corresponding to the highest of the four powers recorded for the adjacent channels in steps e) and g).

8.7.3.4 Characteristics of the adjacent channel transient power measuring device

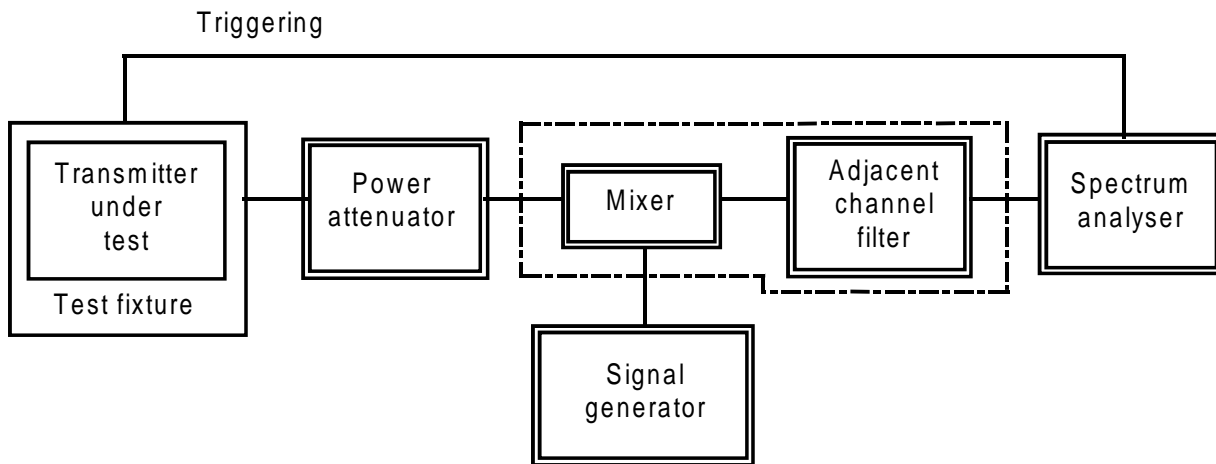

Figure 13: Adjacent channel transient power measuring device measurement arrangement

The adjacent channel transient power measuring device shall be as follows:

mixer: 50 Ω balanced diode mixer; with an appropriate local oscillator level, for example + 7 dBm;

adjacent channel filter: matched to 50 Ω (annex B);

spectrum analyser: 100 kHz bandwidth, peak detection, or power/time measurement provision.

9 Methods of measurement for receiver parameters

9.1 Average usable sensitivity (field strength, data or messages)

9.1.1 Definition

The average usable sensitivity (data) expressed as field strength is the average field strength, expressed in dB μ V/m, produced by a carrier at the nominal frequency of the receiver, modulated with the normal test signal (subclause 7.1) which will, without interference, produce after demodulation a data signal with a specified bit error ratio or a specified successful message ratio. The specified bit error ratio is 10^{-2} . The specified successful message ratio is 80 %. The average is calculated from 8 measurements of field strength where the receiver is rotated in 45° increments starting at an arbitrary orientation.

NOTE: The average usable sensitivity mostly differs only by a small amount from the maximum usable sensitivity to be found in a particular direction. This is due to the properties of the averaging process as used in the formula in subclauses 9.1.2 step j) and 9.1.4 step j). For instance, an error not exceeding 1,2 dB can be found if the sensitivity is equal in seven directions and is extremely poor in the eighth direction. For the same reason the starting direction (or angle) can be selected randomly.

9.1.2 Method of measurement with continuous bit streams under normal test conditions

Arrangements shall be made by the manufacturer to couple the equipment under test to the bit error measuring device by a method which does not affect the radiated field (also subclause 7.9.3.1).

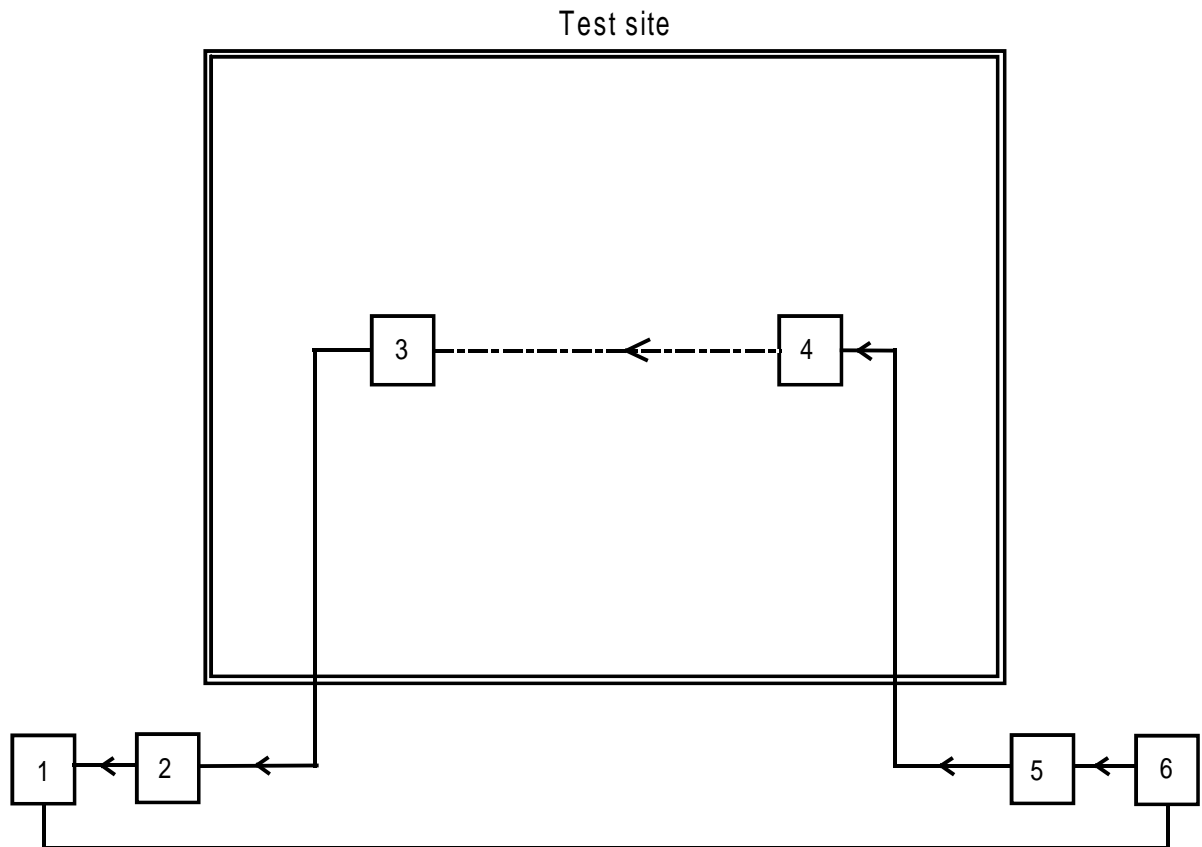

- 1) bit error measuring test set
- 2) photo detector/acoustic coupler
- 3) receiver under test
- 4) test antenna
- 5) signal generator
- 6) bit stream generator

Figure 14: Measurement arrangement

A test site which fulfils the requirements for the specified frequency range of this measurement shall be used. The test antenna shall be orientated for vertical polarisation or for the polarisation in which the equipment under test is intended to operate.

The equipment under test shall be placed on the support in its standard position (clause A.2) and in a random orientation. The raw bit stream produced by the receiver shall be monitored, preferably via a photo detector or an acoustic coupler (clause A.3) in order to avoid disturbing the electromagnetic field in the vicinity of the equipment.

- a) a signal generator shall be connected to the test antenna;

The signal generator shall be at the nominal frequency of the receiver and shall have the normal test signal D-M2 (subclause 7.1).

- b) the bit pattern of the modulating signal shall be compared to the bit pattern provided by the receiver after demodulation, in order to obtain the bit error ratio;
- c) the level of the signal generator shall be adjusted until a bit error ratio of approximately 10^{-1} is obtained;
- d) the test antenna shall be raised or lowered through the specified height range to find the lowest bit error ratio;

The test antenna may not need to be raised or lowered if a test site according to subclause A.1.2 is used, or if the ground floor reflection can effectively be eliminated.

- e) the level of the signal generator shall be re-adjusted until a bit error ratio of 10^{-2} is obtained;
- f) the minimum signal generator level from step d) shall be recorded;
- g) steps c) to f) shall be repeated for the remaining seven positions of the receiver 45° apart;
- h) using the relationship described in subclause A.1.1.2, the eight field strengths X_i ($i=1..8$) in $\mu\text{V/m}$ corresponding to the levels of the signal generator recorded above shall be calculated and recorded;
- j) the average usable sensitivity expressed as field strength E_{mean} ($\text{dB}\mu\text{V/m}$) is given by:

$$E_{\text{mean}} = 20 \log \sqrt{\frac{8}{\sum_{i=1}^8 X_i^2}}$$

where X_i represents each of the eight field strengths calculated in step h);

- k) the reference direction is defined as the direction at which the maximum sensitivity (i.e. corresponding to the minimum field strength recorded during the measurement) occurred during the eight position measurement.

The corresponding direction, height (where applicable) and this reference field strength value shall be recorded.

9.1.3 Method of measurement with continuous bits streams under extreme test conditions

Using the test fixture in the measurement arrangement of figure 15, the measurement of the average usable sensitivity with continuous bit streams shall also be performed under extreme test conditions.

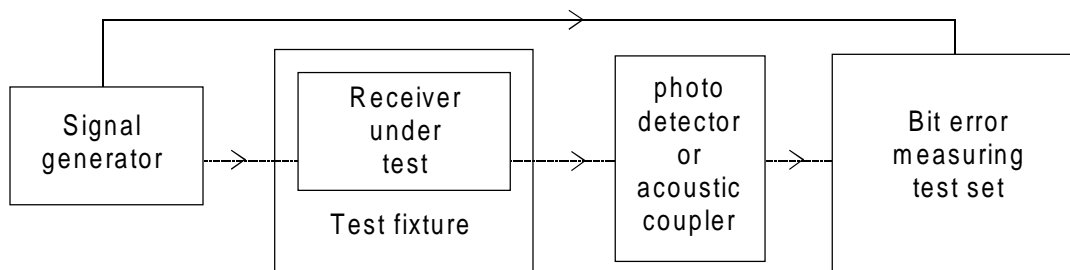

Figure 15: Measurement arrangement

The test signal input level providing a bit error ratio of 10^{-2} shall be determined under extreme and under normal test conditions and the difference in dB shall be calculated. This difference shall be added to the average usable sensitivity to radiated fields expressed in $\text{dB}\mu\text{V/m}$, as calculated in subclause 9.1.2 step j), under normal test conditions, to obtain the sensitivity under extreme test conditions.

9.1.4 Method of measurement with messages under normal test conditions

Arrangements shall be made by the manufacturer to couple the equipment under test to the message measuring device by a method which does not affect the radiated field (subclause 7.9.3.2).

A test site which fulfils the requirements for the specified frequency range of this measurement shall be used. The test antenna shall be orientated for vertical polarisation or for the polarisation in which the equipment under test is intended to operate.

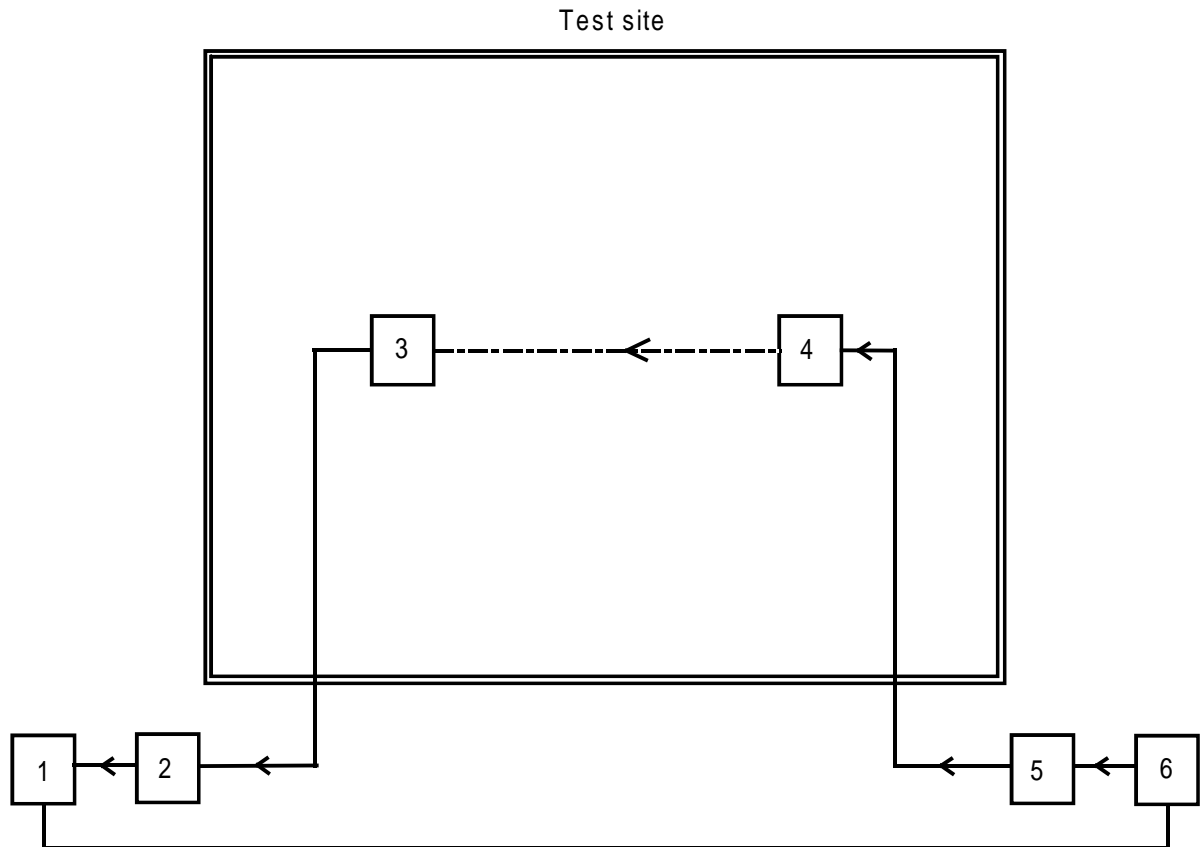

- 1) message measuring test set
- 2) photo detector/acoustic coupler
- 3) receiver under test
- 4) test antenna
- 5) signal generator
- 6) message generator

Figure 16: Measurement arrangement

The equipment under test shall be placed on the support in its standard position (clause A.2) and in a random orientation. A message measuring device shall be coupled to the receiver, preferably via a photo detector or an acoustic coupler (clause A.3) in order to avoid disturbing the electromagnetic field in the vicinity of the equipment.

- a) a signal generator shall be connected to the test antenna;

The signal generator shall be at the nominal frequency of the receiver and shall have the normal test modulation (subclause 7.1).

- b) the level of the signal generator shall be adjusted until a successful message ratio of less than 10 % is obtained;
- c) the test antenna shall be raised or lowered through the specified height range to find the maximum successful message ratio;

The test antenna may not need to be raised or lowered if a test site according to subclause A.1.2 is used, or if the ground floor reflection can effectively be eliminated.

The level of the test signal shall be re-adjusted to produce the successful message ratio specified in step b).

- d) the minimum signal generator level from step c) shall be recorded;

- e) the normal test signal shall be transmitted repeatedly whilst observing in each case whether or not a message is successfully received;

The level of the test signal shall be increased by 2 dB for each occasion that a message is not successfully received.

The procedure shall be continued until three consecutive messages are successfully received.

This level as the minimum signal generator level in this direction shall be recorded.

- f) the level recorded in step e) shall be reduced by 1 dB and the new value shall also be recorded;

The normal test signal (subclause 7.1) shall then be transmitted 20 times. In each case, if a message is not successfully received, the level shall be increased by 1 dB and the new value recorded.

If a message is successfully received, the level shall not be changed until three consecutive messages have been successfully received.

In this case, the level shall be reduced by 1 dB and the new value recorded.

No signal level shall be recorded unless preceded by a change in level.

The average of the values recorded corresponds to the successful message ratio of 80 %. It shall be used to calculate the field strength associated with each position in step h).

- g) steps b) to f) above shall be repeated for the remaining seven positions (45° apart) of the receiver;
- h) using the relationship described in subclause A.1.1.2, the eight field strengths X_i ($i = 1..8$) in $\mu\text{V/m}$ corresponding to the above average values shall be calculated and recorded;
- j) the average usable sensitivity expressed as field strength E_{mean} (dB $\mu\text{V/m}$) is given by:

$$E_{\text{mean}} = 20 \log \sqrt{\frac{8}{\sum_{i=1}^8 X_i^2}}$$

where X_i represents each of the eight field strengths calculated in step h);

- k) the reference direction is defined as the direction at which the maximum sensitivity (i.e. corresponding to the minimum field strength recorded during the measurement) occurred during the eight position measurement.

The corresponding direction, height (where applicable) and this reference field strength value shall be recorded.

9.1.5 Method of measurement with messages under extreme test conditions

Using the test fixture in the measurement arrangement of figure 17, the measurement of the average usable sensitivity with messages shall also be performed under extreme test conditions.

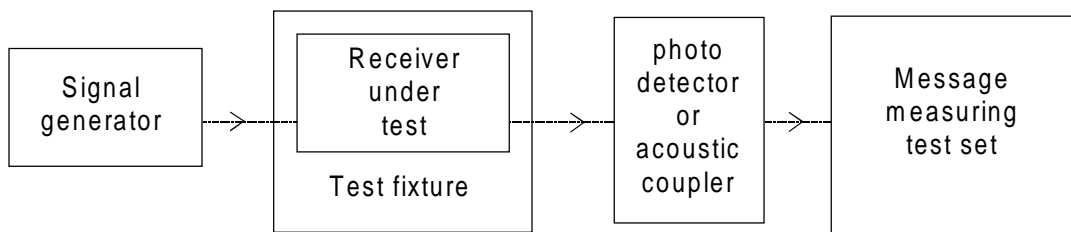

Figure 17: Measurement arrangement

The test signal input level providing a successful message ratio of 80 % shall be determined under extreme and under normal test conditions and the difference in dB shall be calculated. This difference shall be added to the average usable sensitivity to radiated fields expressed in dB μ V/m, as calculated in subclause 9.1.4 step j), under normal test conditions, to obtain the sensitivity under extreme test conditions.

9.1.6 Reference for degradation measurements

9.1.6.1 Definition

Degradation measurements are those measurements which are made on the receiver to establish the degradation of the performance of the receiver due to the presence of (an) unwanted (interfering) signal(s). For such measurements, the level of the wanted signal shall be adjusted to a level which is 3 dB above the limit of the average usable sensitivity, according to the category of the equipment, and expressed as field strength.

Degradation measurements fall into two categories:

- a) those carried out on a test site (subclauses 9.5, 9.7 and clause A.1);
- b) those carried out using a test fixture (subclauses 9.2, 9.3, 9.4, 9.6 and clause A.6).

The test fixture is only used for those tests where the difference in frequency between the wanted and the unwanted test signals is very small in relation to the actual frequency, so that the coupling loss is the same for the wanted and unwanted test signals fed into the test fixture.

9.1.6.2 Procedures for measurements using the test fixture

The test fixture is coupled to the signal generators via a combining network to provide the wanted and unwanted test input signals to the receiver in the test fixture. It is necessary, therefore, to establish the output level of the wanted test signal from the signal generator that results in a signal at the receiver (in the test fixture) which corresponds with the average usable sensitivity (field strength) as specified in subclause 5.2.1.

This test output level from the signal generator for the wanted test signal is then used for all the receiver measurements using the test fixture.

The method for determining the test output level from the signal generator is as follows:

- a) the actual average usable sensitivity of the receiver, measured in accordance with subclauses 9.1.2 step j) or 9.1.4 step j) and expressed as a field strength, shall be used;
- b) the difference between the appropriate limit of the average usable sensitivity specified in subclause 5.2.1, and this actual average usable sensitivity (step a)), expressed in dB, is recorded;
- c) the receiver is then mounted in the test fixture.

The signal generator providing the wanted input signal is coupled to the test fixture via a combining network. All other input ports of the combining network are terminated in 50 Ω loads.

For continuous bit streams, the output level from the signal generator with normal test signal D-M2 (subclause 7.1) is adjusted so that a bit error ratio of 10^{-2} is obtained. This output level is then increased by an amount equal to the difference expressed in dB calculated in subclause 9.1.6.2 step b).

For messages, the output level from the signal generator with normal test modulation (subclause 7.1) is adjusted so that the successful message ratio of 80 % is obtained. This output level is then increased by an amount equal to the difference expressed in dB calculated in subclause 9.1.6.2 step b).

The output level of the signal generator is defined as being the level equivalent to the limit of the average usable sensitivity, for the category of equipment used, expressed as a field strength (subclause 5.2.1).

9.1.6.3 Procedures for measurements on a test site

When measurements are carried out on a test site, the wanted and unwanted signals shall be calibrated in terms of dBµV/m at the location of the equipment under test.

For measurements according to subclauses 9.5, 9.7 and clause A.2, the height of the test antenna and the direction (angle) of the equipment under test shall be that recorded in subclauses 9.1.2 step k) or subclause 9.1.4 step k) (reference direction).

9.2 Error behaviour at high input levels

9.2.1 Definition

The performance at high input levels (noise free operation) is defined by the bit error ratio (continuous bit stream) or the number of messages lost or corrupted at levels significantly above the maximum usable sensitivity.

9.2.2 Method of measurement with continuous bit streams

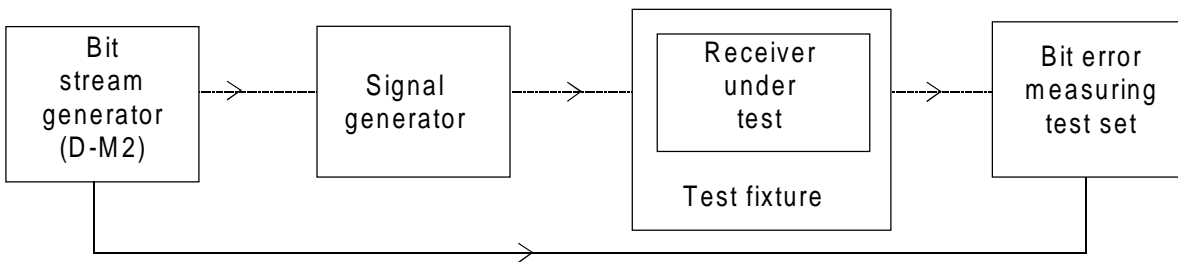

Figure 18: Measurement arrangement

- a) the receiver shall be placed in the test fixture (clause A.6);
- An input signal with a frequency equal to the nominal frequency of the receiver, modulated by the normal test signal D-M2 (subclause 7.1.1) shall be applied to the input of the test fixture.
- b) the bit pattern of the modulating signal shall be compared to the bit pattern obtained from the receiver after demodulation;
 - c) the input signal shall be adjusted to a level of 30 dB above the level of the wanted signal for the degradation measurements (subclause 9.1.6);
 - d) the number of errors that occur at the data output terminals or at a special measuring terminal of the receiver, during a period of 3 minutes, shall be counted;
 - e) the measurement shall be repeated with the input signal to the test fixture at a level of 100 dB above the level of the wanted signal for the degradation measurements (subclause 9.1.6).

9.2.3 Method of measurement with messages

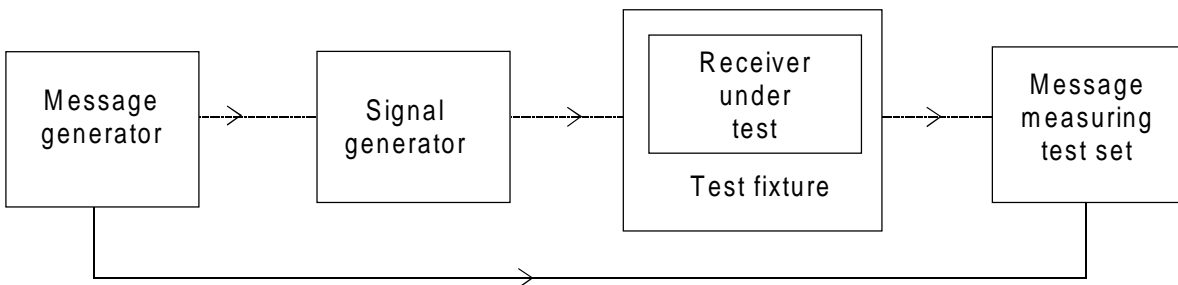

Figure 19: Measurement arrangement

- a) the receiver shall be placed in the test fixture (clause A.6);

A signal of carrier frequency equal to the nominal frequency of the receiver and modulated with the normal test signal (subclause 7.1.2) in accordance with the instructions of the manufacturer (and approved by the testing laboratory) shall be applied to the input of the test fixture.

- b) the input signal of the receiver is adjusted to a level of 30 dB above the level of the wanted signal for the degradation measurements (subclause 9.1.6);
- c) the normal test signal shall be transmitted 100 times whilst observing in each case whether or not a message is successfully received;
- d) the number of occasions when a message is not successfully received shall be recorded;
- e) the measurement shall be repeated with the input signal to the test fixture at a level of 100 dB above the wanted signal for the degradation measurements (subclause 9.1.6).

9.3 Co-channel rejection

9.3.1 Definition

The co-channel rejection is a measure of the capability of the receiver to receive a wanted modulated signal without exceeding a given degradation due to the presence of an unwanted modulated signal, both signals being at the nominal frequency of the receiver.

9.3.2 Method of measurement with continuous bit streams

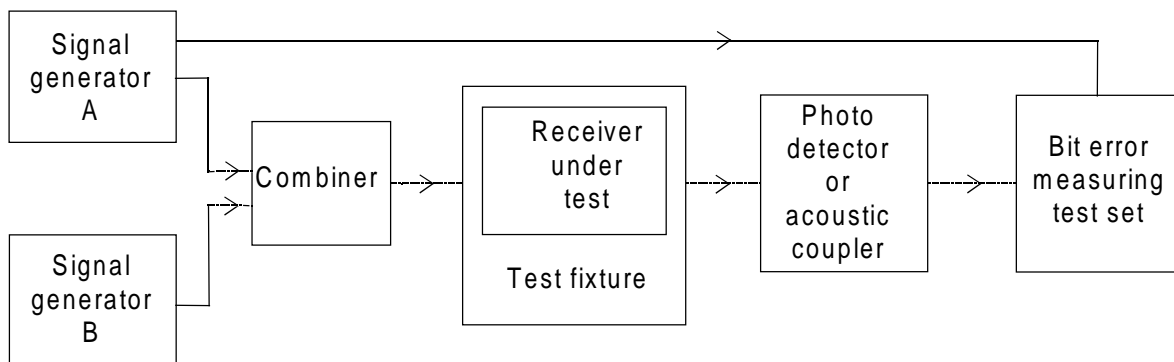

Figure 20: Measurement arrangement

- a) the receiver shall be placed in the test fixture (clause A.6);

Two signal generators A and B shall be connected to the test fixture via a combining network. The wanted signal, provided by signal generator A, shall be at the nominal frequency of the receiver and shall have the normal test signal D-M2 (subclause 7.1.1).

The unwanted signal, provided by signal generator B, shall be modulated with signal A-M3 (see subclause 7.1).

Both input signals shall be at the nominal frequency of the receiver under test.

- b) initially the unwanted signal shall be switched off (maintaining the output impedance). The level of the wanted signal from generator A shall be adjusted to a level which is 3 dB above the level equivalent to the limit of the average usable sensitivity, for the category of equipment used, expressed as a field strength (subclauses 5.2.1 and 9.1.6);
- c) the unwanted signal from generator B shall then be switched on, and its level shall be adjusted until a bit error ratio of approximately 10^{-1} is obtained;
- d) the normal test signal D-M2 shall be transmitted whilst observing the bit error ratio;

- e) the level of the unwanted signal shall be reduced in steps of 1 dB until a bit error ratio of 10^{-2} or better is obtained. The level of the unwanted signal shall then be recorded;
- f) for each frequency of the unwanted signal, the co-channel rejection ratio shall be expressed as the ratio, in dB, of the level of the unwanted signal to the level of the wanted signal. This ratio shall be recorded;
- g) the measurement shall be repeated for displacements of the unwanted signal of $\pm 12\%$ of the channel separation;
- h) the co-channel rejection of the equipment under test shall be expressed as the lowest of the three values expressed in dB, calculated in step f).

The value of the co-channel rejection ratio, expressed in dB, is generally negative (therefore, for example, - 12 dB is lower than - 8 dB).

9.3.3 Method of measurement with messages

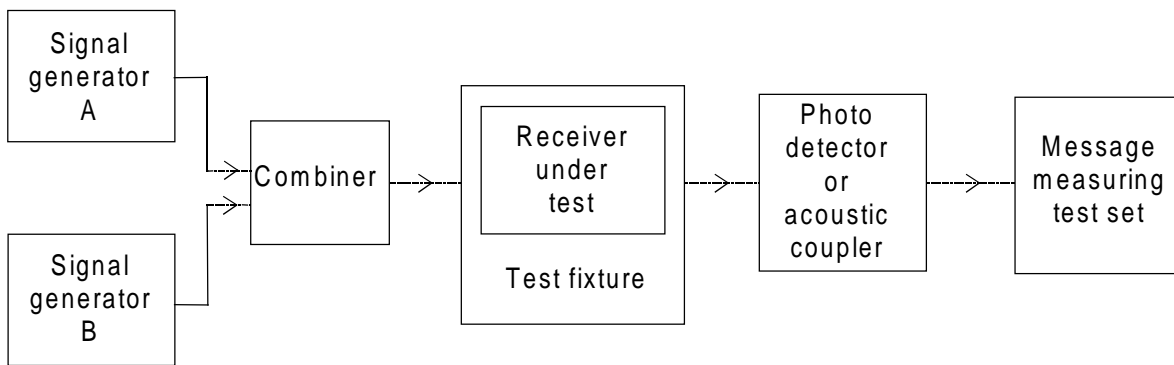

Figure 21: Measurement arrangement

- a) the receiver shall be placed in the test fixture (clause A.6);

Two signal generators A and B shall be connected to the test fixture via a combining network.

The wanted signal, provided by signal generator A, shall be at the nominal frequency of the receiver and shall have the normal test modulation (subclause 7.1.2).

The unwanted signal, provided by signal generator B, shall be modulated with signal A-M3 (subclause 7.1).

Both input signals shall be at the nominal frequency of the receiver under test.
- b) initially, the unwanted signal shall be switched off (maintaining the output impedance);

The level of the wanted signal from generator A shall be adjusted to a level which is 3 dB above the level equivalent to the limit of the average usable sensitivity, for the category of equipment used, expressed as a field strength (subclauses 5.2.1 and 9.1.6).test.
- c) the unwanted signal from signal generator B shall then be switched on and its level shall be adjusted until a successful message ratio of less than 10 % is obtained;
- d) the normal test signal (subclause 7.1.2) shall be transmitted repeatedly whilst observing in each case whether or not a message is successfully received;

The level of the unwanted signal shall be reduced by 2 dB for each occasion that a message is not successfully received.

The procedure shall be continued until three consecutive messages are successfully received.

The level of the input signal shall then be recorded.

- e) the level of the unwanted signal shall be increased by 1 dB and the new value recorded;

The normal test signal (see subclause 7.1.2) shall then be transmitted 20 times. In each case, if a message is not successfully received the level of the unwanted signal shall be reduced by 1 dB and the new value recorded.

If a message is successfully received the level of the unwanted signal shall not be changed until three consecutive messages have been successfully received.

In this case the unwanted signal shall be increased by 1 dB and the new value recorded.

No level of the unwanted signal shall be recorded unless preceded by a change in level.

The average of the values recorded in steps d) and e) (which provides the level corresponding to the successful message ratio of 80 %) shall be recorded.

- f) for each frequency of the unwanted signal, the co-channel rejection ratio shall be expressed as the ratio, in dB, of the average level recorded in step e) to the level of the wanted signal. This ratio shall be recorded;
- g) the measurement shall be repeated for displacements of the unwanted signal of $\pm 12\%$ of the channel separation;
- h) the co-channel rejection ratio of the equipment under test shall be expressed as the lowest of the three values expressed in dB, calculated in step f).

The value of the co-channel rejection ratio, expressed in dB, is generally negative (therefore, for example, - 12 dB is lower than - 8 dB).

9.4 Adjacent channel selectivity

9.4.1 Definition

The adjacent channel selectivity is a measure of the capability of the receiver to receive a wanted modulated signal without exceeding a given degradation due to the presence of an unwanted signal which differs in frequency from the wanted signal by an amount equal to the adjacent channel separation for which the equipment is intended.

9.4.2 Method of measurement with continuous bit streams

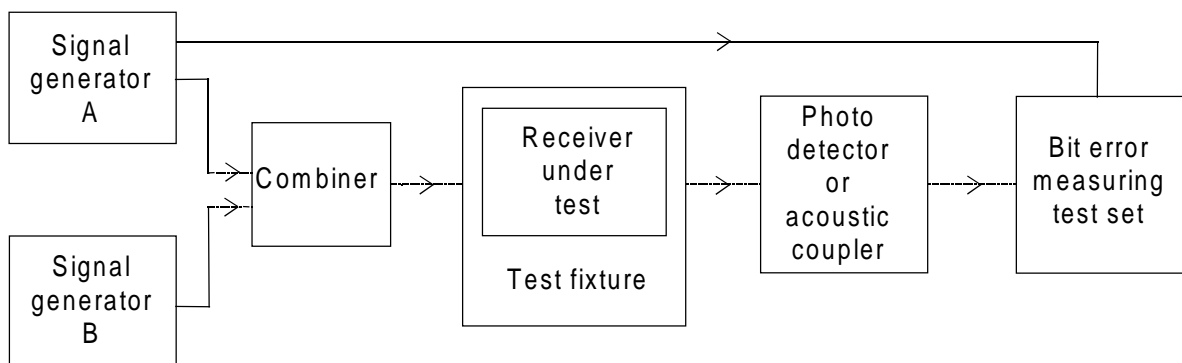

Figure 22: Measurement arrangement

- a) the receiver shall be placed in the test fixture (clause A.6);

Two signal generators A and B shall be connected to the test fixture via a combining network.

The wanted signal, provided by signal generator A, shall be at the nominal frequency of the receiver and shall have the normal test signal D-M2 (subclause 7.1.1).

The unwanted signal, provided by signal generator B, shall be modulated with signal A-M3 (subclause 7.1) and shall be at the frequency of the channel immediately above that of the wanted signal.

- b) initially the unwanted signal shall be switched off (maintaining the output impedance);

The level of the wanted signal from generator A shall be adjusted to a level which is 3 dB above the level equivalent to the limit of the average usable sensitivity, for the category of equipment used, expressed as a field strength (subclauses 5.2.1 and 9.1.6).

- c) the unwanted signal from generator B shall then be switched on; its level shall be adjusted until a bit error ratio of approximately 10^{-1} is obtained;
- d) the normal test signal D-M2 shall be transmitted whilst observing the bit error ratio;
- e) the level of the unwanted signal shall be reduced in steps of 1 dB until a bit error ratio of 10^{-2} or better is obtained. The level of the unwanted signal shall then be recorded;
- f) for each adjacent channel, the selectivity shall be expressed as the ratio in dB of the level of the unwanted signal to the level of the wanted signal. This ratio shall be recorded;

It shall then be converted back into field strengths of the unwanted signals at the receiver location and expressed in dB μ V/m.

- g) the measurement shall be repeated with the unwanted signal at the frequency of the channel below that of the wanted signal;
- h) the adjacent channel selectivity of the equipment under test shall be expressed as the lower of the two values measured in the upper and lower adjacent channel (step f));
- j) unless analogue measurements were made according to ETS 300 296 [6], in which case the adjacent channel selectivity shall be measured at normal test conditions only, the measurement shall be repeated under extreme test conditions (subclauses 6.4.1 and 6.4.2 applied simultaneously), with the level of the wanted signal adjusted to a level which is 3 dB above the level equivalent to the limit of the average usable sensitivity (under extreme test conditions), for the category of equipment used, expressed as a field strength (subclauses 5.2.1 and 9.1.6).

NOTE: This is a valid procedure, because the degradation of adjacent channel selectivity at extreme test conditions is known by the analogue measurement results.

9.4.3 Method of measurement with messages

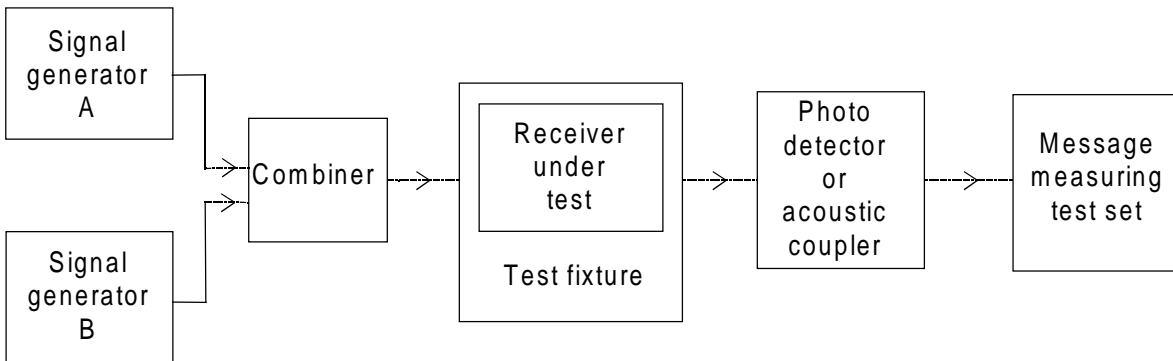

Figure 23: Measurement arrangement

- a) the receiver shall be placed in the test fixture (subclause A.6);

Two signal generators, A and B, shall be connected to the test fixture via a combining network.

The wanted signal, provided by signal generator A, shall be at the nominal frequency of the receiver and shall have normal test modulation (subclause 7.1.2).

The unwanted signal, provided by signal generator B, shall be modulated with signal A-M3 (subclause 7.1) and shall be at the frequency of the channel immediately above that of the wanted signal.

- b) initially the unwanted signal shall be switched off (maintaining the output impedance);

The level of the wanted signal from generator A shall be adjusted to a level which is 3 dB above the level equivalent to the limit of the average usable sensitivity, for the category of equipment used, expressed as a field strength (subclauses 5.2.1 and 9.1.6).

- c) the unwanted signal from generator B shall then be switched on, and its level shall be adjusted until a successful message ratio of less than 10 % is obtained;
- d) the normal test signal (subclause 7.1.2) shall be transmitted repeatedly whilst observing in each case whether or not a message is successfully received;

The level of the unwanted signal shall be reduced by 2 dB for each occasion that a message is not successfully received. The procedure shall be continued until three consecutive messages are successfully received. The level of the input signal shall then be recorded.

- e) the level of the unwanted signal shall be increased by 1 dB and the new value recorded;

The normal test signal (subclause 7.1.2) shall then be transmitted 20 times. In each case, if a message is not successfully received the level of the unwanted signal shall be reduced by 1 dB and the new value recorded.

If a message is successfully received, the level of the unwanted signal shall not be changed until three consecutive messages have been successfully received. In this case the unwanted signal shall be increased by 1 dB and the new value recorded.

No level of the unwanted signal shall be recorded unless preceded by a change in level.

The average of the values recorded in steps d) and e) (which provides the level corresponding to the successful message ratio of 80 %) shall be recorded.

- f) for each adjacent channel, the selectivity shall be expressed as the ratio in dB of the average level recorded in step e) to the level of the wanted signal. This value shall be recorded;

It shall then be converted back into field strengths of the unwanted signals at the receiver location and expressed in dB μ V/m.

- g) the measurement shall be repeated with the unwanted signal at the frequency of the channel below that of the wanted signal;
- h) the adjacent channel selectivity of the equipment under test shall be expressed as the lower of the two values measured in the upper and lower adjacent channel (step f));
- j) unless analogue measurements were made according to ETS 300 296 [6], in which case the adjacent channel selectivity shall be measured at normal test conditions only, the measurement shall be repeated under extreme test conditions (subclauses 6.4.1 and 6.4.2 applied simultaneously), with the level of the wanted signal adjusted to a level which is 3 dB above the level equivalent to the limit of the average usable sensitivity (under extreme test conditions), for the category of equipment used, expressed as a field strength (subclauses 5.2.1 and 9.1.6).

9.5 Spurious response rejection

Spurious responses may occur at all frequencies throughout the frequency spectrum and the requirements of this ETS shall be met for all frequencies. However, for practical reasons the measurements for type testing shall be performed as specified in this ETS. More specifically, this method of measurement is not intended to capture all spurious responses but selects those that have a high probability of being present. However, in a limited frequency range close to the nominal frequency of the receiver, it has been considered impossible to determine the probability of a spurious response and

therefore a search shall be performed over this limited frequency range. This method provides a high degree of confidence that the equipment also meets the requirements at frequencies not being measured.

This measurement need not be carried out if this parameter has been measured according to the requirements of ETS 300 296 [6].

9.5.1 Definition

The spurious response rejection is a measure of the capability of the receiver to receive a wanted modulated signal without exceeding a given degradation due to the presence of an unwanted modulated signal at any other frequency at which a response is obtained.

9.5.2 Introduction to the method of measurement

To determine the frequencies at which spurious responses can occur the following calculations shall be made:

- a) calculation of the "limited frequency range":

The limited frequency range is defined as the frequency of the local oscillator signal (f_{LO}) applied to the first mixer of the receiver plus or minus the sum of the intermediate frequencies (f_{i1}, \dots, f_{in}) and a half of the switching range (sr) of the receiver, (clause 4).

Hence the frequency f_L of the limited frequency range is:

$$f_{LO} - \sum_{j=1}^{j=n} f_{Ij} - \frac{sr}{2} \leq f_L \leq f_{LO} + \sum_{j=1}^{j=n} f_{Ij} + \frac{sr}{2}$$

- b) calculation of frequencies outside the limited frequency range:

A calculation of the frequencies at which spurious responses can occur outside the range determined in a) is made for the remainder of the frequency range of interest, as appropriate, subclause 9.5.6 step g) and subclause 9.5.7 step g).

The frequencies outside the limited frequency range are equal to the harmonics of the frequency of the local oscillator signal (f_{LO}) applied to the first mixer of the receiver plus or minus the first intermediate frequency (f_{i1}) of the receiver.

Hence, the frequencies of these spurious responses are $nf_{LO} \pm f_{i1}$, where n is an integer greater than or equal to 2.

The measurement of the first image response of the receiver shall initially be made to verify the calculation of spurious response frequencies.

For calculations a) and b), the manufacturer shall state the frequency of the receiver, the frequency of the local oscillator signal (f_{LO}) applied to the first mixer of the receiver, the intermediate frequencies (f_{i1} , f_{i2} etc.), and the switching range (sr) of the receiver.

9.5.3 Measurement arrangement

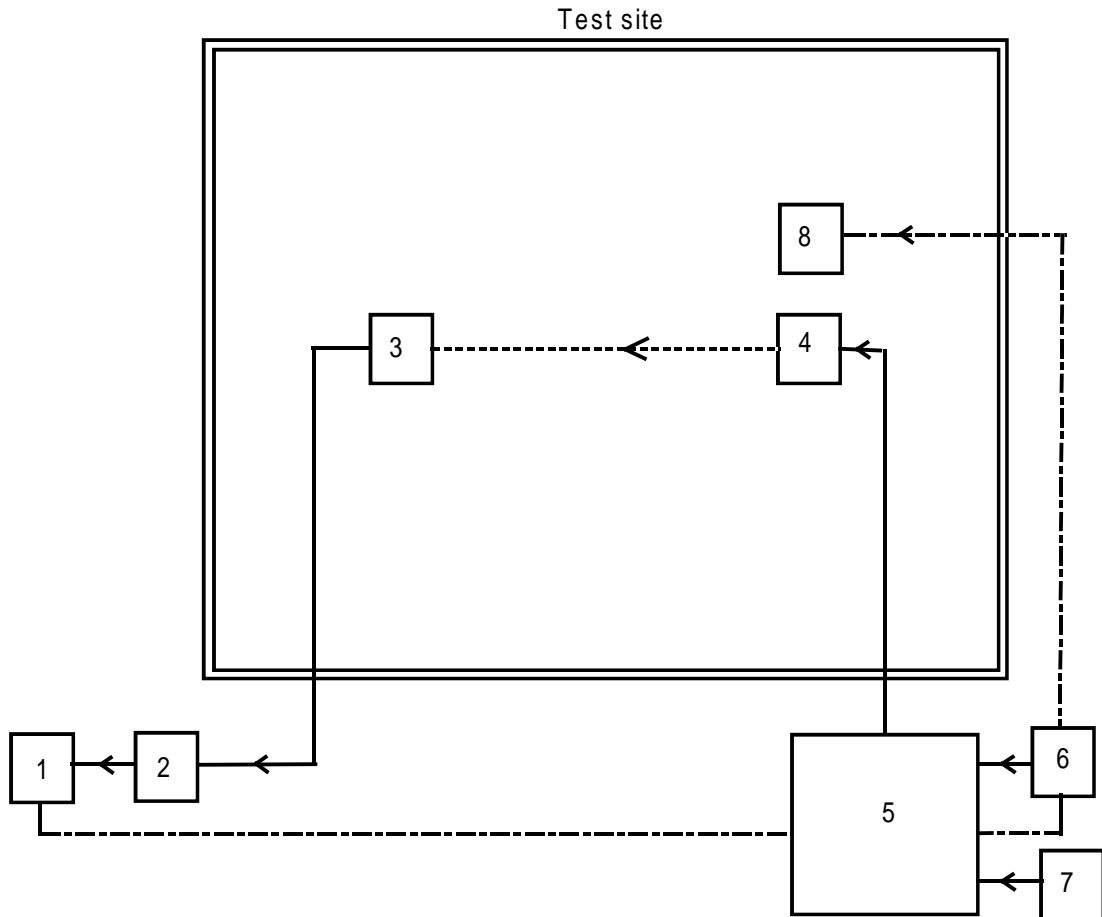

- 1) bit error or message measuring test set
- 2) photo detector/acoustic coupler
- 3) receiver under test
- 4) wide band test antenna
- 5) combining network (used only when one antenna is used)
- 6) signal generator A
- 7) signal generator B
- 8) test antenna for the wanted signal (subclause 9.5.3 step e)

Figure 24: Measurement arrangement

- a) a test site corresponding to that for the measurement of the average usable sensitivity shall be used (subclause 9.1);
- b) the height of the wide band test antenna and the direction (angle) of the equipment under test shall be positioned as indicated in subclauses 9.1.2, 9.1.4 and 9.1.6;
- c) during the course of the measurement it may be necessary to radiate high powers in a broad frequency range, and care must be taken to avoid the signals causing interference to existing services that may be operating in the neighbourhood;
- d) in the presence of a reflective ground plane, the height of the wide band test antenna has to be altered to optimise the reflections from the ground plane. This cannot be done simultaneously for two different frequencies;

If vertical polarisation is used, the ground floor reflection can be effectively eliminated by the use of an appropriate monopole located directly on the ground plane (rod antenna).

- e) in case the wide band test antenna does not cover the necessary frequency range, alternatively two different and sufficiently decoupled antennas may be used;

- f) the equipment under test shall be placed on the support in its standard position (clause A.2) and in the reference direction as indicated in subclauses 9.1.2, 9.1.4 and 9.1.6.

9.5.4 Method of the search over the limited frequency range with continuous bit streams

The measurement shall be performed as follows, using the measurement arrangement of subclause 9.5.3:

- a) two signal generators, A and B, shall be connected to the wide band test antenna via a combining network, where appropriate, or alternatively to two different antennas in accordance with subclause 9.5.3 step e);

The wanted signal, provided by signal generator A, shall be at the nominal frequency of the receiver and shall have the normal test signal D-M2 (subclause 7.1).

The unwanted signal, provided by signal generator B, shall be modulated with a frequency of 400 Hz at a level producing a deviation of ± 5 kHz.

- b) initially, the unwanted signal shall be switched off (maintaining the output impedance);

The level of the wanted signal from signal generator A shall be adjusted to a level which is 3 dB above the level of the limit of the average usable sensitivity, for the category of equipment used, expressed as a field strength (subclauses 5.2.1 and 9.1.6).

- c) the unwanted signal from generator B shall then be switched on and its level shall be adjusted to provide a field strength which is at least 10 dB above, but close to, the limit of the spurious response rejection (subclause 5.2.5) measured at the receiver location, even when on some types of test sites the level of the unwanted signal varies considerably with the frequency due to ground reflections;

The frequency of the unwanted signal shall be varied in increments of 10 kHz over the limited frequency range (subclause 9.5.2 a)) and over the frequencies in accordance with the calculations outside of this frequency range (subclause 9.5.2 b)).

- d) the normal test signal D-M2 shall then be transmitted whilst observing the bit error ratio;
- e) if the bit error ratio is better than 10^{-2} , then no spurious response effects have been detected and the search shall be continued on the next increment of frequency;
- f) if the bit error ratio is worse than 10^{-2} then a spurious response effect has been detected and the search shall be continued on the next increment of frequency;
- g) the frequency of any spurious response detected during the search, and the antenna position and its height shall be recorded for the use in measurements in accordance with subclause 9.5.6.

9.5.5 Method of the search over the limited frequency range with messages

The measurement shall be performed as follows, using the measurement arrangement of subclause 9.5.3:

- a) two signal generators, A and B, shall be connected to the wide band test antenna via a combining network, where appropriate, or alternatively to two different antennas in accordance with subclause 9.5.3 step e);

The wanted signal, provided by signal generator A, shall be at the nominal frequency of the receiver and shall have normal test modulation (subclause 7.1.2).

The unwanted signal, provided by signal generator B, shall be modulated with a frequency of 400 Hz at a level producing a deviation of ± 5 kHz.

- b) initially the unwanted signal shall be switched off (maintaining the output impedance);

The level of the wanted signal from generator A shall be adjusted to a level which is 3 dB above the level of the limit of the average usable sensitivity, for the category of equipment used, expressed as a field strength (subclauses 5.2.1 and 9.1.6).

- c) the unwanted signal from generator B shall then be switched on and its level shall be adjusted to provide a field strength which is at least 10 dB above, but close to, the limit of the spurious response rejection (subclause 5.2.5) measured at the receiver location, even when on some types of test sites the level of the unwanted signal varies considerably with the frequency due to ground reflections;

The frequency of the unwanted signal shall be varied in increments of 10 kHz over the limited frequency range (subclause 9.5.2 a)) and over the frequencies in accordance with calculations outside of this frequency range (subclause 9.5.2 b)).

- d) the normal test signal (subclause 7.1.2) shall be transmitted repeatedly whilst observing in each case whether or not a message is successfully received;
- e) if the successful message ratio is higher than 80 %, then no spurious response effects have been detected and the search shall be continued on the next increment of frequency;
- f) if three consecutive successful messages cannot be received then a spurious response effect has been detected and the search shall be continued on the next increment of frequency;
- g) the frequency of any spurious response detected during the search, and the antenna position and its height shall be recorded for the use in measurements in accordance with subclause 9.5.7.

9.5.6 Method of measurement with continuous bit streams

At each frequency where a spurious response has been found, within and outside the limited frequency range, the measurement shall be performed as follows:

- a) the measurement arrangement is identical to that in subclause 9.5.4;

The wanted signal, provided by signal generator A, shall be at the nominal frequency of the receiver and shall have the normal test signal D-M2 (subclause 7.1.1).

The unwanted signal, provided by signal generator B, shall be modulated with a frequency of 400 Hz with a deviation of 12 % of the channel separation and shall be at the frequency of that spurious response being considered.

- b) initially the unwanted signal shall be switched off (maintaining the output impedance);

The level of the wanted signal from signal generator A shall be adjusted to a level which is 3 dB above the level of the limit of the average usable sensitivity (subclause 9.1.6), for the category of equipment used (subclause 5.2.1), expressed in field strength when measured at the receiver location.

- c) the unwanted signal from generator B shall then be switched on and its level shall be adjusted until a bit error ratio of approximately 10^{-1} is obtained;
- d) the normal test signal D-M2 shall then be transmitted whilst observing the bit error ratio;
- e) the level of the unwanted signal shall be reduced in steps of 1 dB until a bit error ratio of 10^{-2} or better is obtained. The level of the unwanted signal shall then be recorded;
- f) the frequency of the unwanted signal shall be stepped up and down in increments of 20 % of the channel separation and steps c) to e) shall be repeated until the lowest level recorded in step e) is obtained;

For each frequency, the spurious response rejection shall be expressed, as the level in dB μ V/m of the field strength of the unwanted signal at the receiver location, corresponding to the lowest value recorded during this step.

- g) the measurement shall be repeated at all spurious response frequencies found during the search over the limited frequency range, subclauses 9.5.2 and 9.5.4, and at frequencies calculated for the remainder of the spurious response frequencies in the frequency range $f_{Rx}/3,2$ or 30 MHz, whichever is higher, to $3,2 \times f_{Rx}$, where f_{Rx} is the nominal frequency of the receiver, with the antenna position and height recorded in 9.5.4 step g) if appropriate;
- h) the spurious response rejection of the equipment under test shall be expressed as the level in dB μ V/m of the field strength of the unwanted signal, at the receiver location, corresponding to the lowest value recorded in step f).

9.5.7 Method of measurement with messages

At each frequency where a spurious response has been found, within and outside the limited frequency range, the measurement shall be performed as follows:

- a) the measurement arrangement is identical to that in subclause 9.5.5;

The wanted signal, provided by signal generator A, shall be at the nominal frequency of the receiver and shall have normal test modulation (subclause 7.1.2).

The unwanted signal, provided by signal generator B, shall be modulated with a frequency of 400 Hz with a deviation of 12 % of the channel separation and shall be at the frequency of that spurious response being considered.

- b) initially the unwanted signal shall be switched off (maintaining the output impedance);

The level of the wanted signal from signal generator A shall be adjusted to a level which is 3 dB above the level of the limit of the average usable sensitivity (subclause 9.1.6), for the category of equipment used (subclause 5.2.1), expressed in field strength when measured at the receiver location.

- c) the unwanted signal from generator B shall then be switched on and its level shall be adjusted until a successful message ratio of less than 10 % is obtained;
- d) the normal test signal (see subclause 7.1.2) shall be transmitted repeatedly whilst observing in each case whether or not a message is successfully received;

The level of the unwanted signal shall be reduced by 2 dB for each occasion that a message is not successfully received.

The procedure shall be continued until three consecutive messages are successfully received.

The level of the input signal shall then be recorded.

- e) the level of the unwanted signal shall be increased by 1 dB and the new value recorded;

The normal test signal (see subclause 7.1.2) shall then be transmitted 20 times. In each case, if a message is not successfully received, the level of the unwanted signal shall be reduced by 1 dB and the new value recorded.

If a message is successfully received the level of the unwanted signal shall not be changed until three consecutive messages have been successfully received.

In this case the unwanted signal shall be increased by 1 dB and the new value recorded.

No level of the unwanted signal level shall be recorded unless preceded by a change in level.

The average of the values recorded in steps d) and e) (which provides the level corresponding to the successful message ratio of 80 %) shall be recorded.

- f) the frequency of the unwanted signal shall be stepped up and down in increments of 20 % of the channel separation and steps d) and e) shall be repeated until the lowest average level recorded in step e) is obtained;

For each frequency, the spurious response rejection shall be expressed as the level in dB μ V/m of the field strength of the unwanted signal at the receiver location, corresponding to the lowest value recorded during this step.

- g) the measurement shall be repeated at all spurious response frequencies found during the search over the limited frequency range, subclauses 9.5.2 and 9.5.5, and at frequencies calculated for the remainder of the spurious response frequencies in the frequency range $f_{Rx}/3,2$ or 30 MHz, whichever is higher, to $3,2 \times f_{Rx}$, where f_{Rx} is the nominal frequency of the receiver, with the antenna position and height recorded in 9.5.5 step g) if appropriate;
- h) the spurious response rejection of the equipment under test shall be expressed as the level in dB μ V/m of the field strength of the unwanted signal, at the receiver location, corresponding to the lowest value recorded in step f).

9.6 Intermodulation response rejection

This measurement need not be carried out if this parameter has been measured according to the requirements of ETS 300 296 [6].

9.6.1 Definition

The intermodulation response rejection is a measure of the capability of the receiver to receive a wanted modulated signal, without exceeding a given degradation due to the presence of two or more unwanted signals with a specific frequency relationship to the wanted signal frequency.

9.6.2 Method of measurement with continuous bit streams

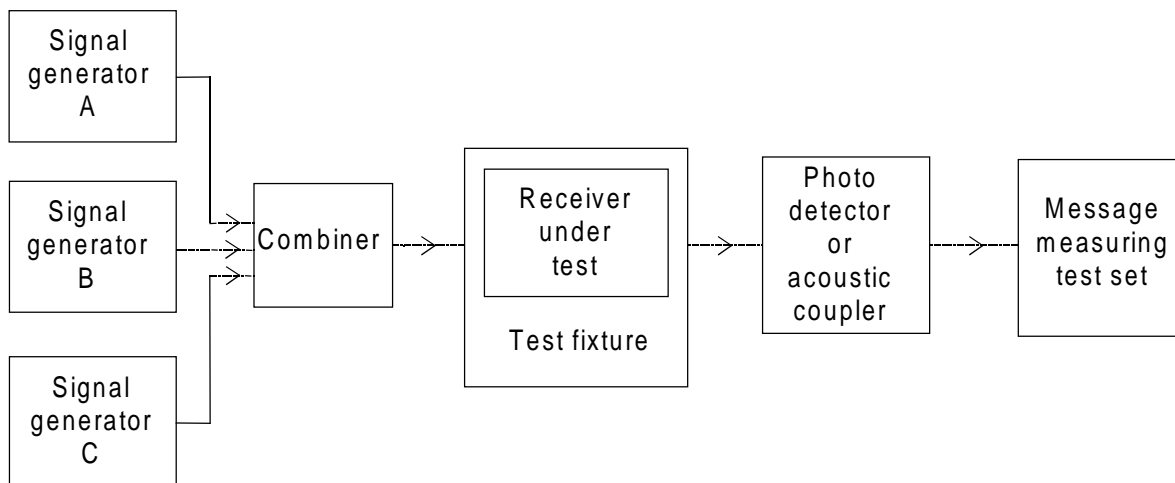

Figure 25: Measurement arrangement

- a) the receiver shall be placed in the test fixture (clause A.6);

Three signal generators, A, B and C, shall be connected to the test fixture via a combining network.

The wanted signal, provided by signal generator A, shall be at the nominal frequency of the receiver and shall have normal test signal D-M2 (subclause 7.1.1).

The first unwanted signal, provided by signal generator B, shall be unmodulated and adjusted to a frequency 50 kHz above the nominal frequency of the receiver.

The second unwanted signal, provided by signal generator C, shall be modulated with signal A-M3 (subclause 7.1) and adjusted to a frequency 100 kHz above the nominal frequency of the receiver.

- b) initially, the unwanted signals shall be switched off (maintaining the output impedances);

The level of the wanted signal from generator A shall be adjusted to a level which is 3 dB above the level equivalent to the limit of the average usable sensitivity, for the category of equipment used, expressed as a field strength (subclauses 5.2.1 and 9.1.6).

- c) the two unwanted signals from signal generators B and C shall then be switched on. Their levels shall be maintained equal and shall be adjusted until a bit error ratio of 10^{-1} or worse is obtained;
- d) the test signal D-M2 shall then be transmitted whilst observing the bit error ratio;
- e) the level of the unwanted signals shall be reduced in steps of 1 dB until a bit error ratio of 10^{-2} or better is obtained. The level of the unwanted signals shall then be recorded;
- f) for each configuration of the unwanted signals, the intermodulation response rejection shall be expressed as the ratio, in dB, of the level of the unwanted signals to the level of the wanted signal. This ratio shall be recorded;

It shall then be converted back into field strength of the unwanted signals at the receiver location and expressed in $\text{dB}\mu\text{V}/\text{m}$.

- g) the measurements shall be repeated with the unwanted signal generator B at the frequency 50 kHz below that of the wanted signal and the frequency of the unwanted signal generator C at the frequency 100 kHz below that of the wanted signal;
- h) the intermodulation response rejection of the equipment under test shall be expressed as the lower of the two values calculated in step f).

9.6.3 Method of measurement with messages

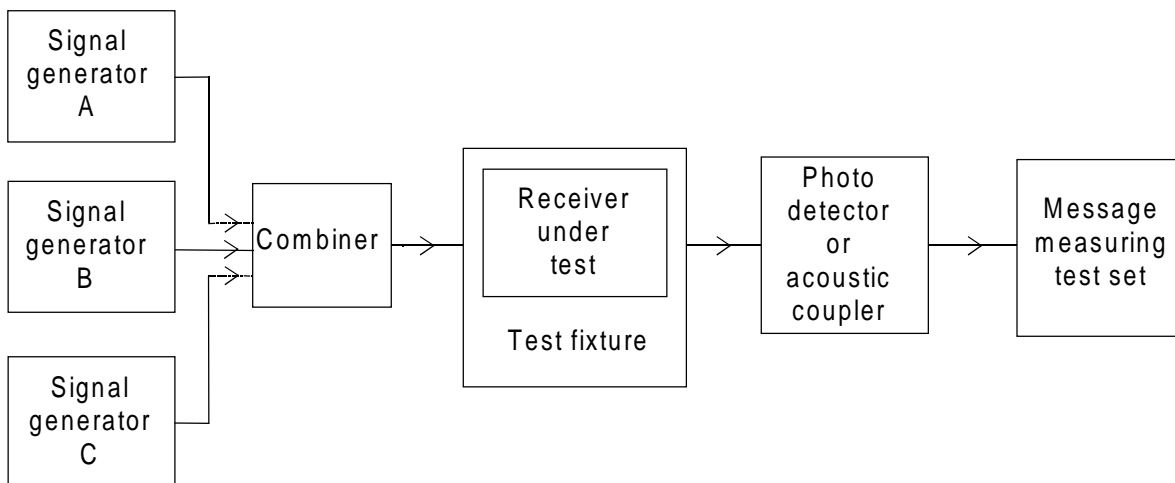

Figure 26: Measurement arrangement

- a) the receiver shall be placed in the test fixture (clause A.6);

Three signal generators, A, B and C, shall be connected to the test fixture via a combining network.

The wanted signal, provided by signal generator A, shall be at the nominal frequency of the receiver and shall have normal test modulation (subclause 7.1.2).

The first unwanted signal, provided by signal generator B, shall be unmodulated and adjusted to a frequency 50 kHz above the nominal frequency of the receiver.

The second unwanted signal, provided by signal generator C, shall be modulated with signal A-M3 (subclause 7.1) and adjusted to a frequency 100 kHz above the nominal frequency of the receiver.

- b) initially, the unwanted signals shall be switched off (maintaining the output impedances);

The level of the wanted signal from generator A shall be adjusted to a level which is 3 dB above the level equivalent to the limit of the average usable sensitivity, for the category of equipment used, expressed as a field strength (subclauses 5.2.1 and 9.1.6).

- c) the two unwanted signals from signal generators B and C shall then be switched on. Their levels shall be maintained equal and shall be adjusted until a successful message ratio of less than 10 % is obtained;
- d) the normal test signal (subclause 7.1.2) shall be transmitted repeatedly whilst observing in each case whether or not a message is successfully received;

The level of the unwanted signals shall be reduced by 2 dB for each occasion that a message is not successfully received.

The procedure shall be continued until three consecutive messages are successfully received. The level of the input signals shall then be recorded.

- e) the level of the unwanted signals shall be increased by 1 dB and the new value recorded;

The normal test signal (subclause 7.1.2) shall then be transmitted 20 times. In each case, if a message is not successfully received, the level of the unwanted signals shall be reduced by 1 dB and the new value recorded.

If a message is successfully received, the input level of the unwanted signals shall not be changed until three consecutive messages have been successfully received. In this case the level of the unwanted signals shall be increased by 1 dB and the new value recorded.

No level of the unwanted signals shall be recorded unless preceded by a change in level.

The average of the values recorded in steps d) and e) (which provides the level corresponding to the successful message ratio of 80 %) shall be recorded.

- f) for each configuration of the unwanted signals, the intermodulation response rejection shall be expressed as the ratio in dB of the average level recorded in step e) to the level of the wanted signal. This ratio shall be recorded;

It shall then be converted back into field strength of the unwanted signals at the receiver location and expressed in dB μ V/m.

- g) the measurement shall be repeated with the unwanted signal generator B at the frequency 50 kHz below that of the wanted signal and the frequency of the unwanted signal generator C at the frequency 100 kHz below that of the wanted signal;
- h) the intermodulation response rejection of the equipment under test shall be expressed as the lower of the two values calculated in step f).

9.7 Blocking or desensitisation

This measurement need not be carried out if this parameter has been measured according to the requirements of ETS 300 296 [6].

9.7.1 Definition

Blocking is a measure of the capability of the receiver to receive a wanted modulated signal without exceeding a given degradation due to the presence of an unwanted signal at any frequencies other than those of the spurious responses or the adjacent channels.

9.7.2 Method of measurement with continuous bit streams

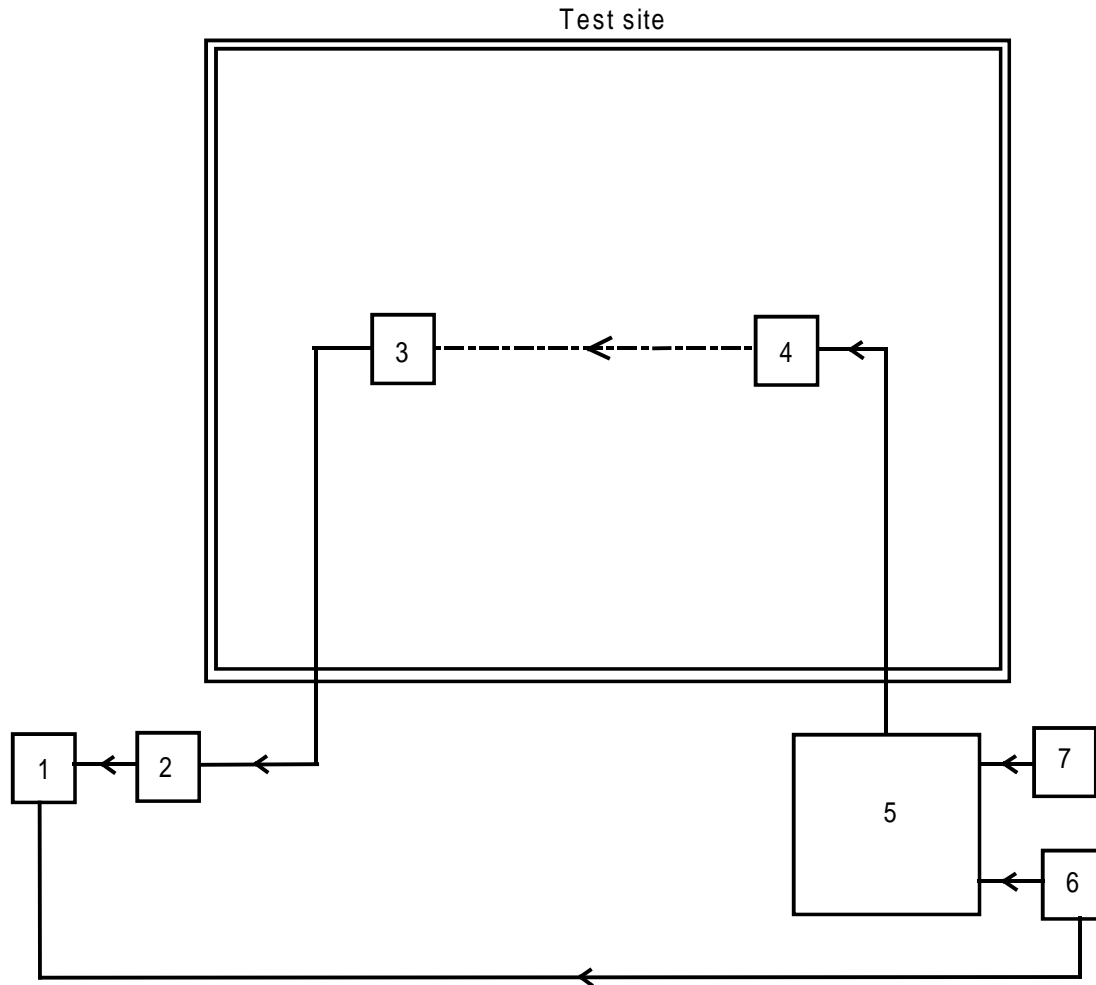

- 1) bit error measuring test set
- 2) photo detector/acoustic coupler
- 3) receiver under test
- 4) wide band test antenna
- 5) combining network
- 6) signal generator A
- 7) signal generator B

Figure 27: Measurement arrangement

A test site corresponding to that for the measurement of the average usable sensitivity shall be used (subclause 9.1).

The equipment under test shall be placed on the support in its standard position (clause A.2) and in the reference direction (subclause 9.1.2 step k)) and the measurement shall be performed as follows:

- a) two signal generators, A and B, shall be connected to the wide band test antenna via a combining network;

The wanted signal, provided by signal generator A, shall be at the nominal frequency of the receiver and shall have normal test signal D-M2 (subclause 7.1.1).

The unwanted signal, provided by signal generator B, shall be unmodulated and shall be at a frequency from 1 MHz to 10 MHz away from the nominal frequency of the receiver.

For practical reasons the measurements shall be carried out at frequencies of the unwanted signal at approximately ± 1 MHz, ± 2 MHz, ± 5 MHz and ± 10 MHz, avoiding those frequencies at which spurious responses occur (subclause 9.5).

- b) initially the unwanted signal shall be switched off (maintaining the output impedance);

The level of the wanted signal from generator A shall be adjusted to a level which is 3 dB above the level of the limit of the average usable sensitivity, for the category of equipment used, expressed as a field strength (subclauses 5.2.1 and 9.1.6).
- c) the unwanted signal from generator B shall then be switched on and its level shall be adjusted until a bit error ratio of approximately 10^{-1} is obtained;
- d) the normal test signal D-M2 shall then be transmitted whilst observing the bit error ratio;
- e) the level of the unwanted signal shall be reduced in steps of 1 dB until a bit error ratio of 10^{-2} or better is obtained. The level of the unwanted signal shall then be recorded;
- f) for each frequency, the blocking or desensitisation shall be expressed as the level in dB μ V/m of the field strength of the unwanted signal at the receiver location. This value shall be recorded;
- g) the measurement shall be repeated for all the frequencies defined in step a);
- h) the blocking or desensitisation of the equipment under test shall be expressed as the level in dB μ V/m of the field strength of the unwanted signal, at the receiver location, corresponding to the lowest value recorded in step f).

9.7.3 Method of measurement with messages

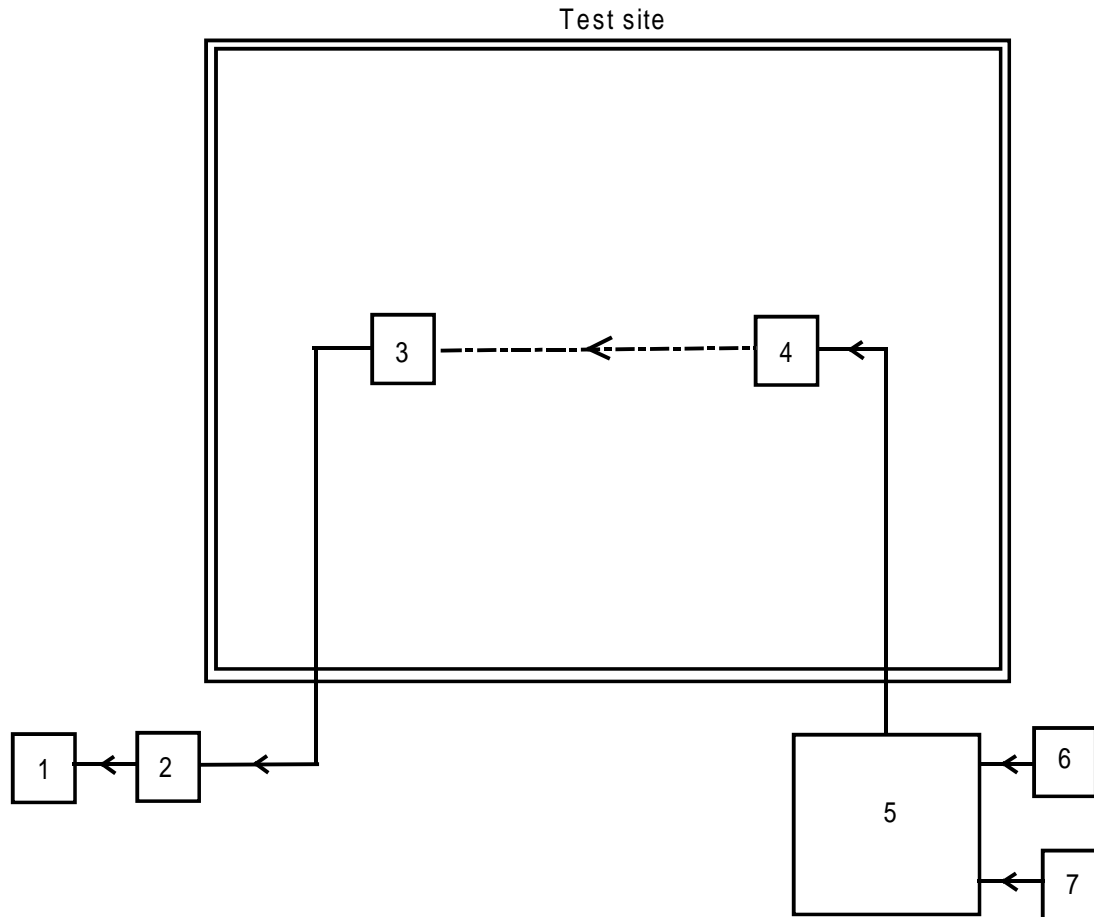

- 1) message measuring test set
- 2) photo detector/acoustic coupler
- 3) receiver under test
- 4) wide band test antenna
- 5) combining network
- 6) signal generator A
- 7) signal generator B

Figure 28: Measurement arrangement

A test site corresponding to that for the measurement of the average usable sensitivity shall be used (subclause 9.1).

The equipment under test shall be placed on the support in its standard position (clause A.2) and in the reference direction (subclause 9.1.4 step k)) and the measurement shall be performed as follows:

- a) two signal generators A and B shall be connected to the wide band test antenna via a combining network;

The wanted signal, provided by signal generator A, shall be at the nominal frequency of the receiver and shall have normal test modulation (subclause 7.1.2).

The unwanted signal, provided by signal generator B, shall be unmodulated and shall be at a frequency from 1 MHz to 10 MHz away from the nominal frequency of the receiver.

For practical reasons the measurements shall be carried out at frequencies of the unwanted signal at approximately ± 1 MHz, ± 2 MHz, ± 5 MHz and ± 10 MHz, avoiding those frequencies at which spurious responses occur (subclause 9.5).

- b) initially, the unwanted signal shall be switched off (maintaining the output impedance);

The level of the wanted signal from generator A shall be adjusted to a level which is 3 dB above the level of the limit of the average usable sensitivity, for the category of equipment used, expressed as a field strength (subclauses 5.2.1 and 9.1.6).

- c) the unwanted signal from generator B shall then be switched on and its level shall be adjusted until a successful message ratio of less than 10 % is obtained;
- d) the normal test signal (subclause 7.1.2) shall be transmitted repeatedly whilst observing in each case whether or not a message is successfully received;

The level of the unwanted signal shall be reduced by 2 dB for each occasion that a message is not successfully received.

The procedure shall be continued until three consecutive messages are successfully received.

The level of the input signal shall then be recorded.

- e) the level of the unwanted signal shall be increased by 1 dB and the new value recorded;

The normal test signal (subclause 7.1.2) shall then be transmitted 20 times. In each case if a message is not successfully received, the level of the unwanted signal shall be reduced by 1 dB and the new value recorded.

If a message is successfully received the level of the unwanted signal shall not be changed until three consecutive messages have been successfully received.

In this case the unwanted signal level shall be increased by 1 dB and the new value recorded.

No level of the unwanted signal shall be recorded unless preceded by a change in level.

The average of the values recorded in steps d) and e) (which provides the level corresponding to the successful message ratio of 80 %) shall be recorded.

- f) for each frequency, the blocking or desensitisation shall be expressed as the level in dB μ V/m of the field strength of the unwanted signal at the receiver location, corresponding to the average value recorded in step e). For each frequency, the level shall be recorded;
- g) the measurement shall be repeated for all the frequencies defined in step a);
- h) the blocking or desensitisation of the equipment under test shall be expressed as the level in dB μ V/m of the field strength of the unwanted signal, at the receiver location, corresponding to the lowest value recorded in step f).

9.8 Spurious radiations

This measurement need not be carried out if this parameter has been measured according to the requirements of ETS 300 296 [6].

9.8.1 Definition

Spurious radiations from the receiver are components at any frequency radiated by the equipment and its antenna.

They are specified as the radiated power of any discrete signal.

9.8.2 Method of measurement

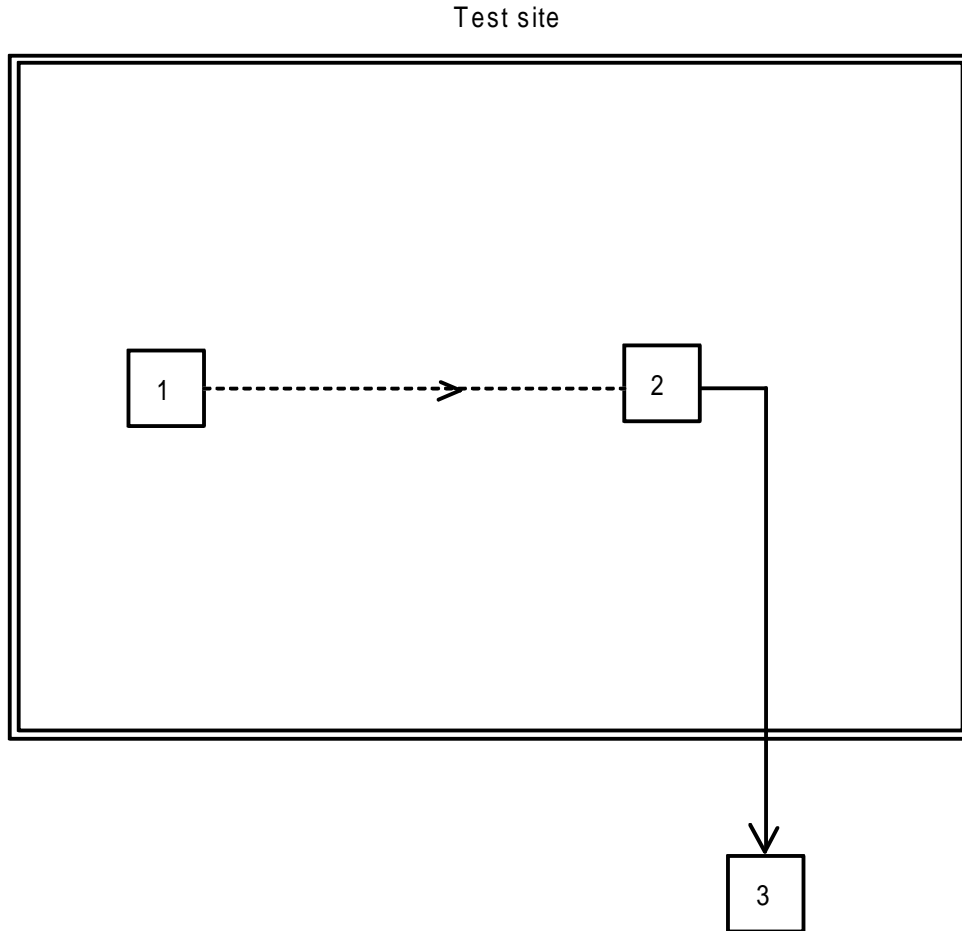

- 1) receiver under test
- 2) test antenna
- 3) spectrum analyser or selective voltmeter

Figure 29: Measurement arrangement

- a) a test site which fulfils the requirements of the specified frequency range of this measurement shall be used. The test antenna shall be orientated for vertical polarisation and connected to a spectrum analyser or a selective voltmeter. The resolution bandwidth of the spectrum analyser or selective voltmeter shall be the smallest bandwidth available which is greater than the spectral width of the spurious component being measured;
- b) the receiver under test shall be placed on the support in its standard position (clause A.2). The radiation of any spurious component shall be detected by the test antenna and the spectrum analyser or selective voltmeter over the frequency range 30 MHz to 4 GHz. In addition, for equipment operating on frequencies above 470 MHz, measurements shall be repeated over the frequency range 4 GHz to 12,75 GHz;

The frequency of each spurious component shall be recorded. If the test site is disturbed by radiation coming from outside, this qualitative search may be performed in a screened room with reduced distance between the receiver under test and the test antenna.

- c) at each frequency at which a component has been detected, the spectrum analyser or selective voltmeter shall be tuned and the test antenna shall be raised or lowered through the specified height range until the maximum signal level is detected on the spectrum analyser or selective voltmeter;
- d) the receiver shall be rotated through 360° about a vertical axis, until a higher maximum signal is received;

- e) the test antenna shall be raised or lowered again through the specified height range until a maximum signal is obtained. This signal level shall be recorded;

The test antenna may not need to be raised or lowered if the measurement is carried out on a test site according to subclause A.1.2.

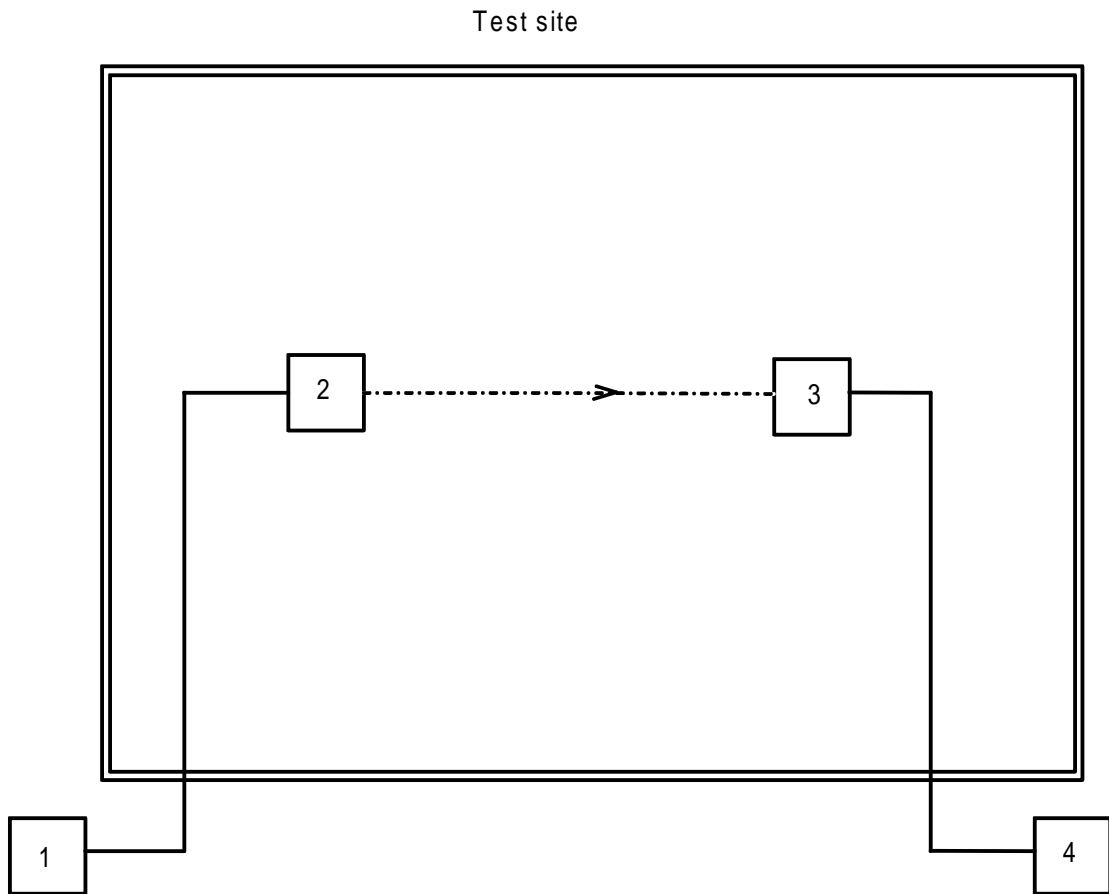

- 1) signal generator
- 2) substitution antenna
- 3) test antenna
- 4) spectrum analyser or selective voltmeter

Figure 30: Measurement arrangement

- f) using the measurement arrangement in figure 30, the substitution antenna shall replace the receiver antenna in the same position and in vertical polarisation. It shall be connected to the signal generator;
- g) for each frequency at which a component has been detected, the signal generator and spectrum analyser or selective voltmeter shall be tuned and the test antenna shall be raised or lowered through the specified height range until the maximum signal level is detected on the spectrum analyser or selective voltmeter;

The test antenna may not need to be raised or lowered if the measurement is carried out on a test site according to subclause A.1.2.

The level of the signal generator giving the same signal level on the spectrum analyser or selective voltmeter as in step e) above shall be recorded. This value, after correction due to the gain of the substitution antenna and the cable loss between the signal generator and the substitution antenna, is the radiated spurious component at this frequency.

- h) measurements of step b) to step g) shall be repeated with the test antenna orientated in horizontal polarisation.

10 Measurement uncertainty

Table 8: Absolute measurement uncertainties: maximum values

Parameter	Uncertainty (note 1)
RF frequency	$\pm 1 \times 10^{-7}$
Radiated RF power	± 6 dB
Conducted RF power variations using a test fixture	$\pm 0,75$ dB
Adjacent channel power	± 5 dB
Sensitivity	± 3 dB
Two-signal measurement, valid to 4 GHz (using a test fixture)	± 4 dB
Two-signal measurements using radiated fields (note)	± 6 dB
Three-signal measurement (using a test fixture)	± 3 dB
Radiated emission of transmitter, valid to 12,75 GHz	± 6 dB
Radiated emission of receiver, valid to 12,75 GHz	± 6 dB
Transmitter transient attack time	± 20 %
Transmitter transient release time	± 20 %
Transmitter transient frequency	± 250 Hz
NOTE 1:	Valid up to 1 GHz unless otherwise stated.
NOTE 2:	For blocking and spurious response rejection measurements.

For the test methods according to this ETS these uncertainty figures are valid to a confidence level of 95 % calculated according to the methods to be described in ETR 028 [4].

Annex A (normative): Radiated measurements

A.1 Test sites and general arrangements for measurements involving the use of radiated fields

Any of the following four test sites may be used.

A.1.1 Open air test site

A.1.1.1 Description

The term "open air" should be understood from an electromagnetic point of view. Such a test site may be really in open air or alternatively with walls and ceiling transparent to the radio waves at the frequencies considered.

An open air test site may be used to perform the measurements using the radiated measurement methods described in clauses 8 and 9. Absolute or relative measurements can be performed on transmitters or on receivers; absolute measurements of field strength require a calibration of the test site.

Sufficient precautions shall be taken to ensure that reflections from extraneous objects adjacent to the site do not degrade the measurement results, in particular:

- no extraneous conducting objects having any dimension in excess of a quarter wavelength of the highest frequency tested shall be in the immediate vicinity of the site;
- all cables shall be as short as possible; as much of the cables as possible shall be on the ground plane or preferably below; and the low impedance cables shall be screened.

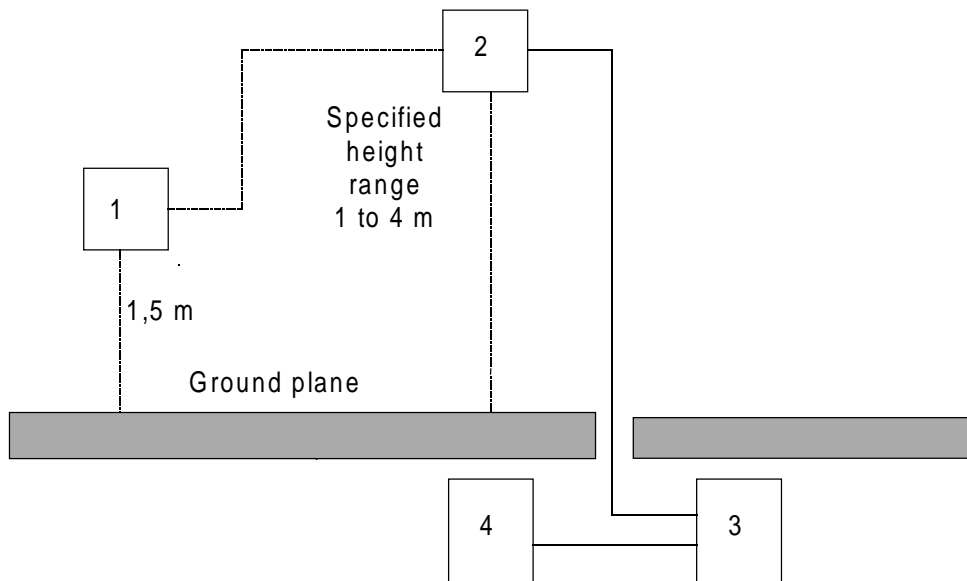

- 1) equipment under test
- 2) test antenna
- 3) high pass filter (necessary for strong fundamental Tx radiation)
- 4) spectrum analyser or measuring receiver

Figure A.1: Measuring arrangement

A.1.1.2 Establishment of a relationship between signal levels and field strength

This procedure allows the creation, in a given place, of a known field strength by the means of a signal generator connected to a test antenna. It is valid only at a given frequency for a given polarisation and for the exact position of the test antenna.

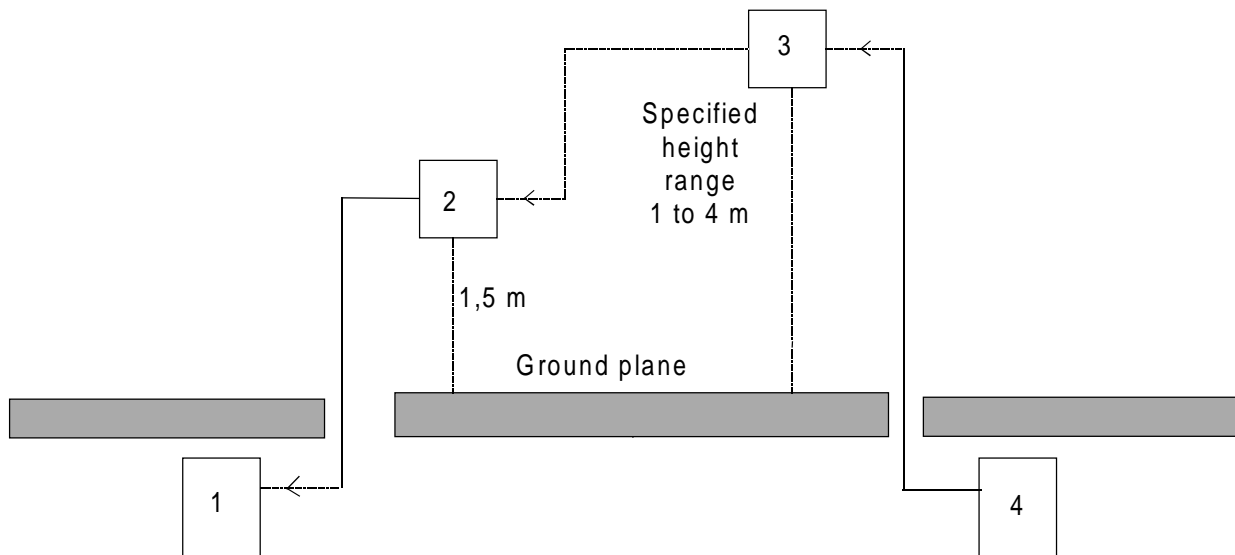

- 1) selective voltmeter
- 2) substitution antenna
- 3) test antenna
- 4) signal generator

Figure A.2: Measuring arrangement

All the equipment shall be adjusted to the frequency used.

The test antenna and the substitution antenna shall have the same polarisation.

The substitution antenna connected to the selective voltmeter constitutes a calibrated field strength meter.

- a) the signal generator level shall be adjusted to produce the required field strength as measured on the selective voltmeter;
- b) the test antenna shall be raised or lowered through the specified range until the maximum signal level is detected on the selective voltmeter;
- c) the signal generator level shall be readjusted to produce the required field strength as measured on the selective voltmeter. Thus a relationship has been established between the signal generator level and the field strength.

A.1.2 Anechoic chamber

A.1.2.1 General

An anechoic chamber is a well shielded chamber covered inside with radio frequency absorbing material and simulating a free space environment. It is an alternative site on which to perform the measurements using the radiated measurement methods described in clauses 8 and 9. Absolute or relative measurements can be performed on transmitters or on receivers. Absolute measurements of field strength require a calibration of the anechoic chamber. The test antenna, equipment under test and substitution antenna are used in a way similar to that at the open air test site, but are all located at the same fixed height above the floor.

A.1.2.2 Description

An anechoic chamber should meet the requirements for shielding loss and wall return loss as shown in figure A.3. Figure A.4 shows an example of the construction of an anechoic chamber having a base area of 5 m by 10 m and a height of 5 m. The ceiling and walls are coated with pyramidally formed absorbers approximately 1 m high. The base is covered with special absorbers which form the floor. The available internal dimensions of the chamber are 3 m x 8 m x 3 m, so that a maximum measuring distance of 5 m in the middle axis of this chamber is available. The floor absorbers reject floor reflections so that the antenna height need not be changed. Anechoic chambers of other dimensions may be used.

At 100 MHz the measuring distance can be extended up to a maximum of 2 wavelengths.

A.1.2.3 Influence of parasitic reflections

For free-space propagation in the far field the relationship of the field strength X and the distance R is given by $X = X_0 \times (R_0/R)$, where X_0 is the reference field strength and R_0 is the reference distance. This relationship allows relative measurements to be made as all constants are eliminated within the ratio and neither cable attenuation nor antenna mismatch or antenna dimensions are of importance.

If the logarithm of the foregoing equation is used, the deviation from the ideal curve can be easily seen because the ideal correlation of field strength and distance appears as a straight line. The deviations occurring in practice are then clearly visible. This indirect method shows quickly and easily any disturbances due to reflections and is far less difficult than the direct measurement of reflection attenuation.

With an anechoic chamber of the dimensions given above at low frequencies below 100 MHz there are no far field conditions, but the wall reflections are stronger, so that careful calibration is necessary. In the medium frequency range from 100 MHz to 1 GHz the dependence of the field strength to the distance meets the expectations very well. Above 1 GHz, because more reflections will occur, the dependence of the field strength to the distance will not correlate so closely.

A.1.2.4 Mode of use

The mode of use is the same as for an open air test site, the only difference being that the test antenna does not need to be raised and lowered whilst searching for a maximum, which simplifies the method of measurement.

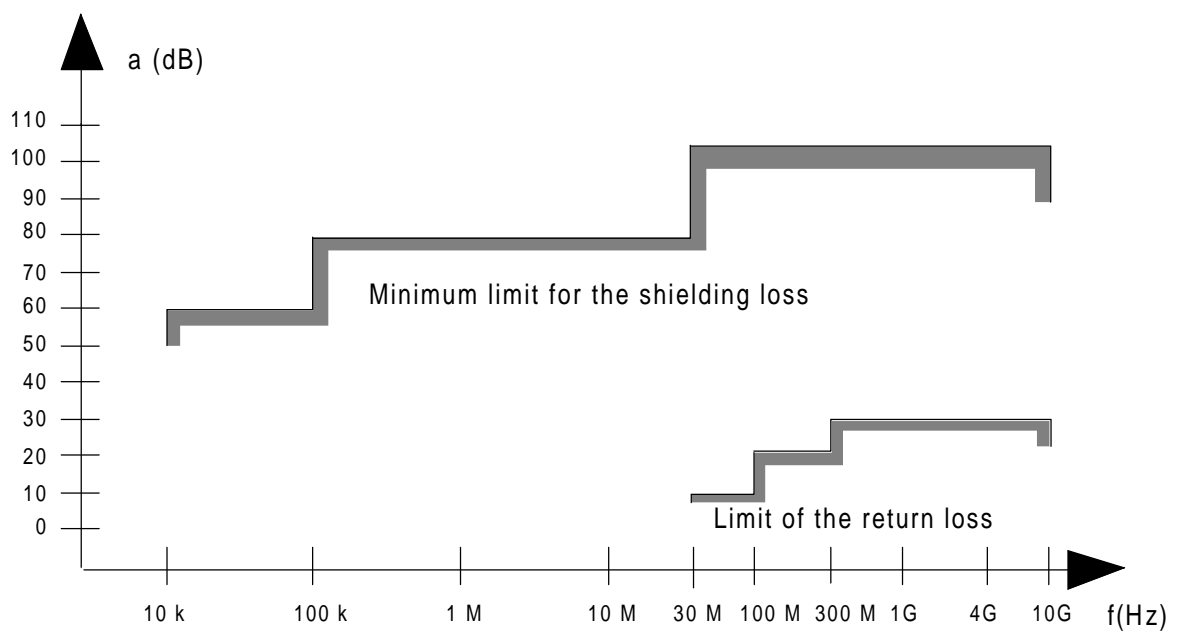

Figure A.3: Specification for shielding and reflections

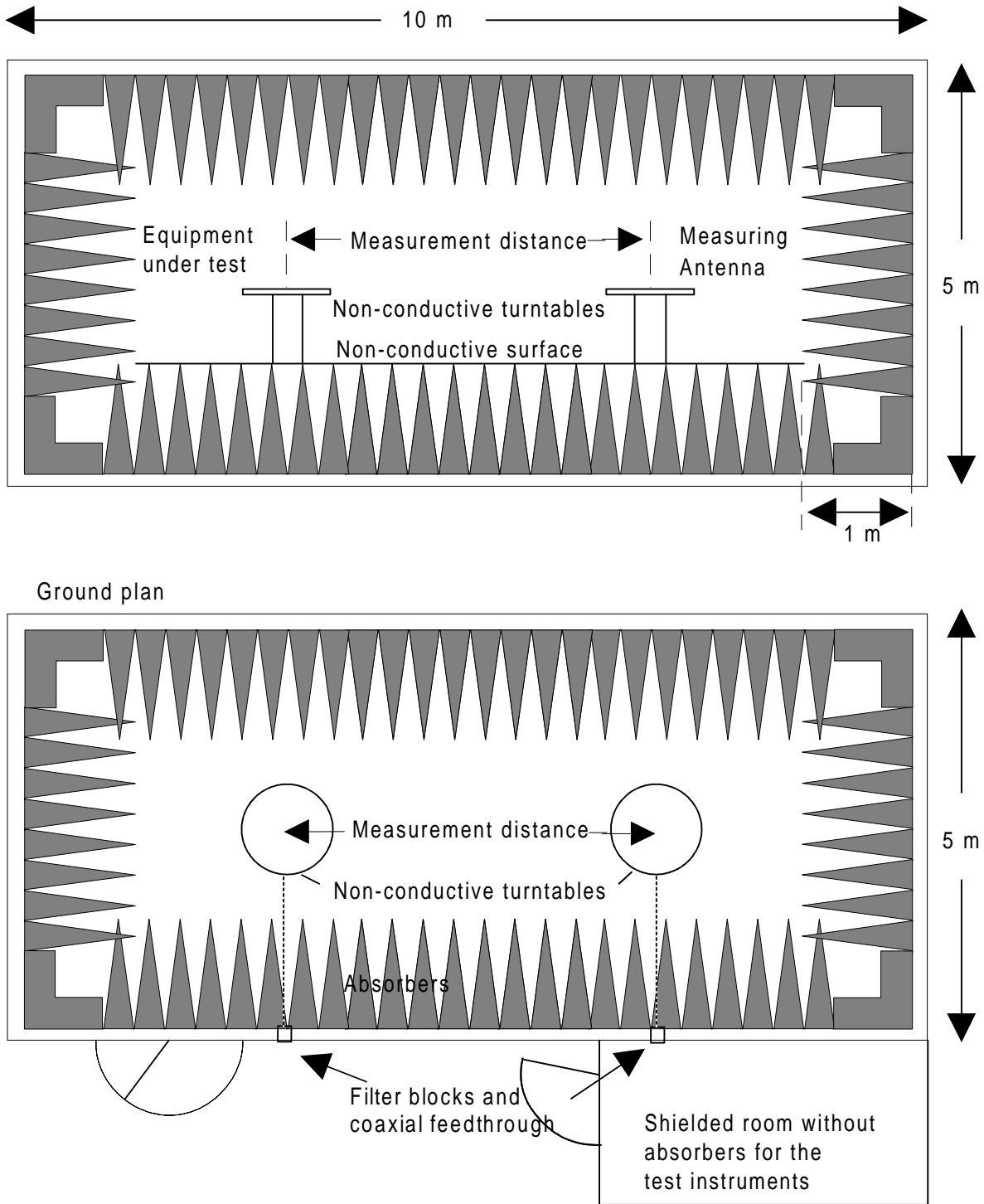

Figure A.4: Anechoic shielded chamber for simulated free space measurements

A.1.3 Stripline arrangement

A.1.3.1 General

The stripline arrangement is a RF coupling device for coupling the integral antenna of an equipment to a 50 Ω radio frequency terminal. This allows the radiated measurements to be performed without an open air test site but in a restricted frequency range. Absolute or relative measurements can be performed; absolute measurements require a calibration of the stripline arrangement.

A.1.3.2 Description

The stripline is made of three highly conductive sheets forming part of a transmission line which allows the equipment under test to be placed within a known electric field. They shall be sufficiently rigid to support the equipment under test.

Two examples of stripline characteristics are given below:

	IEC 489-3 App. J	FTZ No. 512 TB 9
Useful frequency range (MHz)	1 to 200	0,1 to 4 000
Equipment size limits (antenna included):	length 200 mm	1 200 mm
	width 200 mm	1 200 mm
	height 250 mm	400 mm

A.1.3.3 Calibration

The aim of calibration is to establish at any frequency a relationship between the voltage applied by the signal generator and the field strength at the designated test area inside the stripline.

A.1.3.4 Mode of use

The stripline arrangement may be used for all radiated measurements within its calibrated frequency range.

The method of measurement is the same as the method using a open air test site with the following change. The stripline arrangement input socket is used instead of the test antenna.

A.1.4 Indoor test site

A.1.4.1 Description

An indoor test site is a partially screened site, where the wall located behind the test sample is covered with a radio frequency absorbing material and a corner reflector is used with the test antenna. It may be used when the frequency of the signals being measured is greater than 80 MHz.

The measurement site may be a laboratory room with a minimum area of 6 m by 7 m and at least 2,7 m in height.

Apart from the measuring apparatus and the operator, the room shall be as free as possible from reflecting objects other than the walls, floor and ceiling.

The potential reflections from the wall behind the equipment under test are reduced by placing a barrier of absorbent material in front of it. The corner reflector around the test antenna is used to reduce the effect of reflections from the opposite wall and from the floor and ceiling in the case of horizontally polarised measurements. Similarly, the corner reflector reduces the effects of reflections from the side walls for vertically polarised measurements. For the lower part of the frequency range (below approximately 175 MHz) no corner reflector or absorbent barrier is needed. For practical reasons, the half wavelength antenna in figure A.5 may be replaced by an antenna of constant length, provided that this length is between a quarter wavelength and one wavelength at the frequency of measurement and the sensitivity of the measuring system is sufficient. In the same way the distance of half wavelength to the apex may be varied.

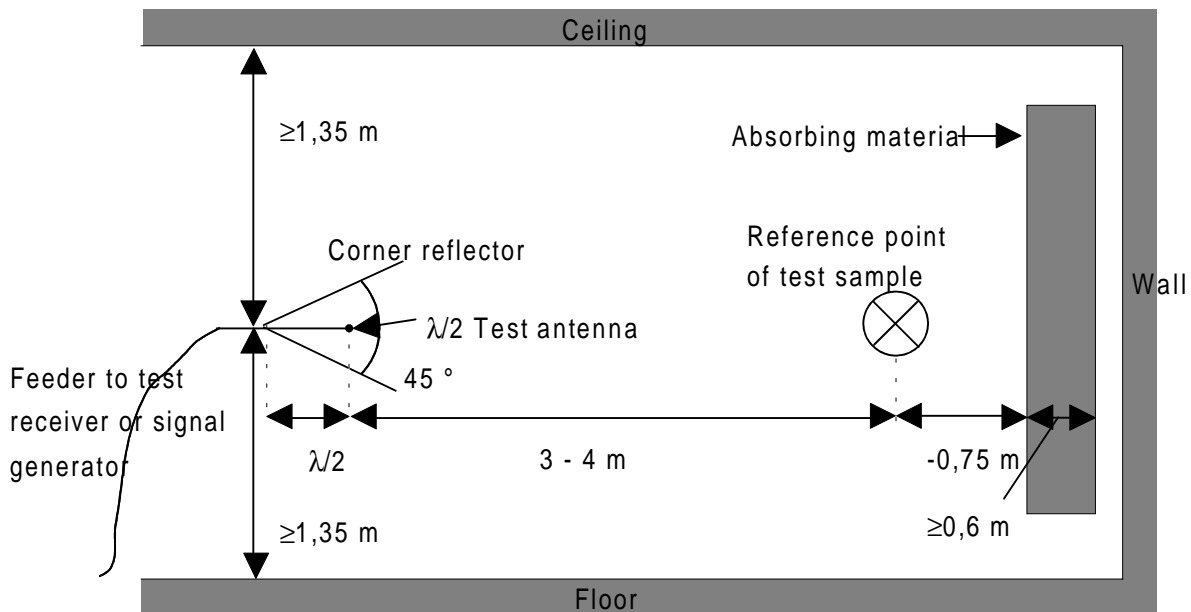

Figure A.5: Indoor test site arrangement (shown for horizontal polarisation)

A.1.4.2 Test for parasitic reflections

To ensure that errors are not caused by the propagation path approaching the point at which phase cancellation between direct and the remaining reflected signals occurs, the substitution antenna shall be moved through a distance of ± 10 cm in the direction of the test antenna as well as in the two directions perpendicular to this first direction.

If these changes of distance cause a signal change of greater than 2 dB, the test sample should be repositioned until a change of less than 2 dB is obtained.

A.1.4.3 Mode of use

The mode of use is the same as for an open air test site, the only difference being that the test antenna does not need to be raised and lowered whilst searching for a maximum, which simplifies the method of measurement.

A.2 Standard position

The standard position in all test sites, except the stripline arrangement, for equipment which is not intended to be worn on a person, including hand-held equipment, shall be on a non-conducting support, height 1,5 m, capable of rotating about a vertical axis through the equipment. The standard position of the equipment shall be the following:

- for equipment with an integral antenna, it shall be placed in the position closest to normal use as declared by the manufacturer;
- for equipment with a rigid external antenna, the antenna shall be vertical;
- for equipment with a non-rigid external antenna, the antenna shall be extended vertically upwards by a non-conducting support.

Equipment which is intended to be worn on a person may be tested using a simulated man as support. The simulated man comprises a rotatable acrylic tube filled with salt water, placed on the ground. The container shall have the following dimensions:

- height $1,7 \pm 0,1$ m;
- inside diameter 300 ± 5 mm;
- sidewall thickness $5 \pm 0,5$ mm.

The container shall be filled with a salt (NaCl) solution of 1,5 g per litre of distilled water.

The equipment shall be fixed to the surface of the simulated man, at the appropriate height for the equipment.

NOTE: To reduce the weight of the simulated man it may be possible to use an alternative tube which has a hollow centre of 220 mm maximum diameter.

In the stripline arrangement the equipment under test or the substitution antenna is placed in the designated test area in the normal operational position, relative to the applied field, on a pedestal made of a low dielectric material (dielectric constant less than 2).

A.3 Acoustic coupler

A.3.1 General

When radiation measurements are performed, on the receiver, the audio output voltage should be conducted from the receiver to the measuring equipment, without perturbing the field near the receiver.

This perturbation can be minimized by using wires with high resistivity associated to a test equipment with a high input impedance (IEC 489-3, Appendix F).

When this situation is not applicable, an acoustic coupler shall be used.

NOTE: When using this acoustic coupler care should be exercised that possible ambient noise does not influence the test result.

A.3.2 Description

The acoustic coupler comprises a plastic funnel, an acoustic pipe and a microphone with a suitable amplifier.

The acoustic pipe shall be long enough (e.g. 2 m) to reach from the equipment under test to the microphone which is located in a position that will not disturb the RF field. The acoustic pipe shall have an inner diameter of about 6 mm and a wall thickness of about 1,5 mm and should be sufficiently flexible to allow the platform to rotate.

The plastic funnel shall have a diameter appropriate to the size of the loudspeaker in the equipment under test, with soft foam rubber glued to its edge, it shall be fitted to one end of the acoustic pipe and the microphone shall be fitted to the other end. It is very important to fix the centre of the funnel in a reproducible position relative to the equipment under test, since the position of the centre has a strong influence on the frequency response that will be measured. This can be achieved by placing the equipment in a close fitting acoustic mounting jig, supplied by the manufacturer, of which the funnel is an integral part.

The microphone shall have a response characteristic flat within 1 dB over a frequency range of 50 Hz to 20 kHz, a linear dynamic range of at least 50 dB. The sensitivity of the microphone and the receiver audio output level shall be suitable to measure a signal to noise ratio of at least 40 dB at the nominal audio output level of the equipment under test. Its size should be sufficiently small to couple to the acoustic pipe.

The frequency correcting network shall correct the frequency response of the acoustic coupler so that the acoustic SINAD measurement is valid, IEC 489-3 (see Bibliography).

A.3.3 Calibration

The aim of the calibration of the acoustic coupler is to determine the acoustic SINAD ratio which is equivalent to the SINAD ratio at the receiver output.

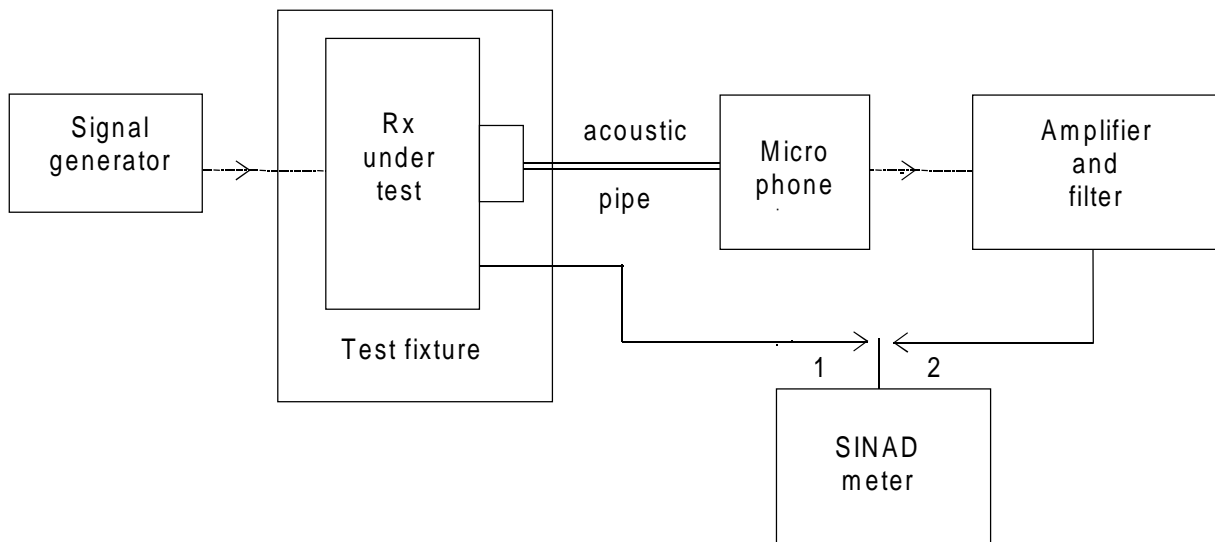

Figure A.6: Measuring arrangement for calibration

- a) the acoustic coupler shall be mounted to the equipment, if necessary using a test fixture. A direct electrical connection to the terminals of the output transducer will be made. A signal generator shall be connected to the receiver input (or to the test fixture input). The signal generator shall be at the nominal frequency of the receiver and shall be modulated by the normal test modulation;
- b) where possible, the receiver volume control shall be adjusted to give at least 50 % of the rated audio output power and, in the case of stepped volume controls, to the first step that provides an output power of at least 50 % of the rated audio output power;
- c) the test signal input level shall be reduced until an electrical SINAD ratio of 20 dB is obtained, the connection being in position 1. The signal input level shall be recorded;
- d) with the same signal input level, the acoustic equivalent SINAD ratio shall be measured and recorded, the connection being in position 2;
- e) steps c) and d) above shall be repeated for an electrical SINAD ratio of 14 dB, and the acoustic equivalent SINAD ratio measured and recorded.

A.4 Test antenna

When the test site is used for radiation measurements the test antenna is used to detect the field from both the test sample and the substitution antenna. When the test site is used for the measurement of receiver characteristics the antenna is used as a transmitting antenna. This antenna is mounted on a support capable of allowing the antenna to be used in either horizontal or vertical polarisation and for the height of its centre above the ground to be varied over the specified range. Preferably test antennas with pronounced directivity should be used. The size of the test antenna along the measurement axis shall not exceed 20 % of the measuring distance.

A.5 Substitution antenna

The substitution antenna is used to replace the equipment under test. For measurements below 1 GHz the substitution antenna shall be a half wavelength dipole resonant at the frequency under consideration, or a shortened dipole, calibrated to the half wavelength dipole. For measurements between 1 and 4 GHz either a half wavelength dipole or a horn radiator may be used. For measurements above 4 GHz a horn radiator shall be used. The centre of this antenna shall coincide with the reference point of the test sample it has replaced. This reference point shall be the volume centre of the sample when its antenna is mounted inside the cabinet, or the point where an outside antenna is connected to the cabinet.

The distance between the lower extremity of the dipole and the ground shall be at least 30 cm.

NOTE: The gain of a horn antenna is generally expressed relative to an isotropic radiator.

A.6 Test fixture

A.6.1 Description

The test fixture is a radio frequency coupling device associated with an integral antenna equipment for coupling the integral antenna to a 50 Ω radio frequency terminal at the working frequencies of the equipment under test. This allows certain measurements to be performed using the conducted measurement methods. Only relative measurements may be performed and only those at or near frequencies for which the test fixture has been calibrated.

In addition, the test fixture shall provide:

- a) a connection to an external power supply;
- b) an audio interface either by direct connection or by an acoustic coupler.

The test fixture normally shall be provided by the manufacturer.

The performance characteristics of the test fixture shall be approved by the testing laboratory and shall conform to the following basic parameters:

- a) the coupling loss shall not be greater than 30 dB;
- b) a coupling loss variation over the frequency range used in the measurement which does not exceed 2 dB;
- c) circuitry associated with the RF coupling shall contain no active or non linear devices;
- d) the VSWR at the 50 Ω socket shall not be greater than 1,5 over the frequency range of the measurements;
- e) the coupling loss shall be independent of the position of the test fixture and be unaffected by the proximity of surrounding objects or people. The coupling loss shall be reproducible when the equipment under test is removed and replaced;
- f) the coupling loss shall remain substantially constant when the environmental conditions are varied.

The characteristics and calibration shall be included in the test report.

A.6.2 Calibration

The calibration of the test fixture establishes a relationship between the output of the signal generator and the field strength applied to the equipment inside the test fixture.

The calibration is valid only at a given frequency and for a given polarisation of the reference field.

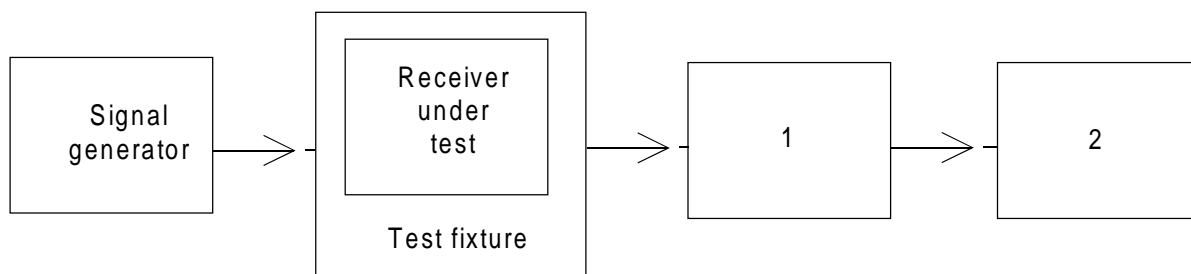

- 1) AF load/acoustic coupler
- 2) distortion factor/audio level meter and psophometric filter

Figure A.7: Measuring arrangement for calibration

- a) using the method described in subclause 9.1, measure the sensitivity expressed as field strength, and note the value of this field strength in dB μ V/m and the polarisation used;
- b) the receiver is now placed in the test fixture which is connected to the signal generator. The level of the signal generator producing a SINAD of 20 dB shall be recorded;
- c) the calibration of the test fixture is thus the linear relationship between the field strength in dB μ V/m and the signal generator level in dB μ V emf.

A.6.3 Mode of use

The test fixture may be used to facilitate some of the measurements in clauses 8 and 9 on equipment with an integral antenna.

It is used in the radiated carrier power and measured usable sensitivity expressed as a field strength measurements in clauses 8 and 9 to enable a measurement to be made under extreme test conditions.

For the transmitter measurements calibration is not required.

For the receiver measurements calibration is necessary.

To apply the specified wanted signal level expressed in field strength, convert it into the signal generator level (emf) using the calibration of the test fixture. Apply this value with the signal generator.

Annex B (normative): Specifications for adjacent channel power measurement arrangements

B.1 Power measuring receiver specification

B.1.1 General

The power measuring receiver is used for the measurement of the transmitter adjacent channel power. It consists of a mixer and oscillator, an IF filter, an amplifier, a variable attenuator and a level indicator as shown below.

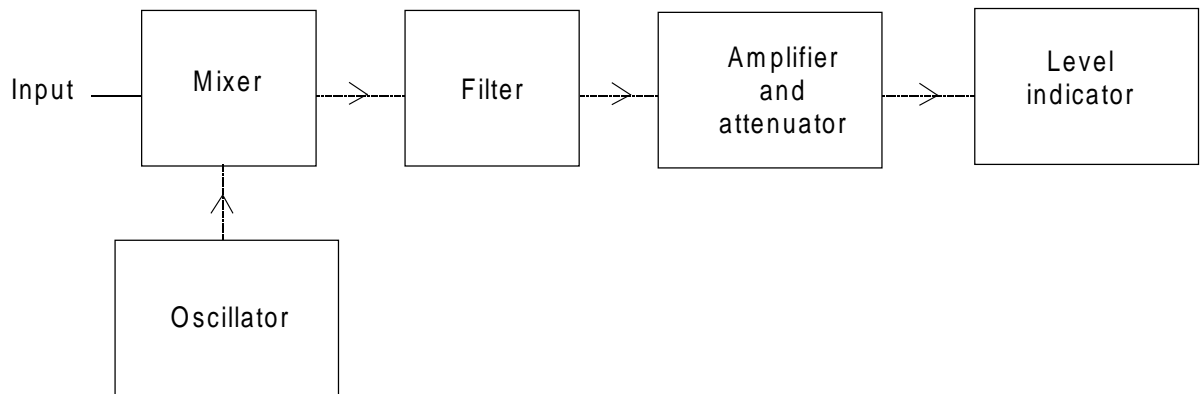

Figure B.1

The technical characteristics of the power measuring receiver are given below.

B.1.2 IF filter

The IF filter shall be within the limits of the selectivity characteristics given in the following diagram. Depending on the channel separation, the selectivity characteristics shall keep the frequency separations and tolerances given in the following table. The minimum attenuation of the filter outside the 90 dB attenuation points shall be equal to or greater than 90 dB.

NOTE: A symmetrical filter may be used provided that each side meets the tighter tolerances and the D2 points have been calibrated relative to the - 6 dB response. When a non-symmetrical filter is used the receiver should be designed such that the tighter tolerance is used close to the carrier.

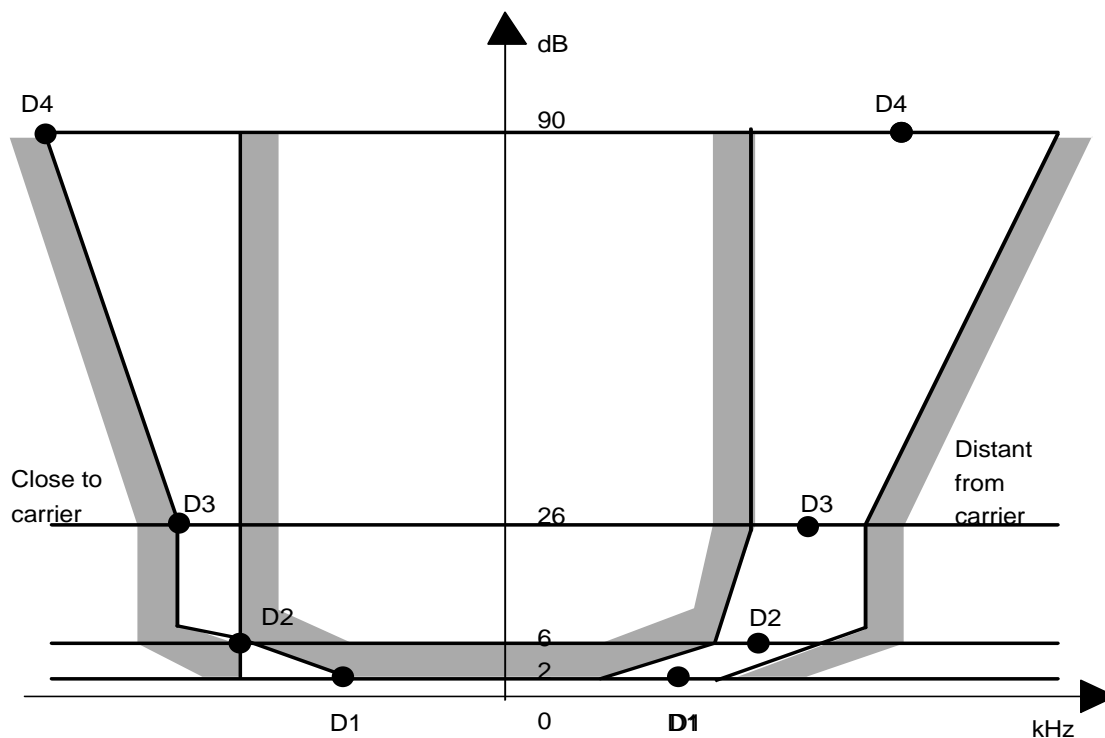

Figure B.2: limits of the selectivity characteristic

Table B.1: Selectivity characteristic

Channel separation (kHz)	Frequency separation of filter curve from nominal centre frequency of adjacent channel (kHz)			
	D1	D2	D3	D4
12,5	3	4,25	5,5	9,5
20	4	7,0	8,25	12,25
25	5	8,0	9,25	13,25

Depending on the channel separation, the attenuation points shall not exceed the tolerances given in table B.2 and table B.3.

Table B.2: Attenuation points close to carrier

Channel separation (kHz)	Frequency separation of filter curve from nominal centre frequency of adjacent channel (kHz)			
	D1	D2	D3	D4
12,5	+ 1,35	± 0,1	- 1,35	- 5,35
20	+ 3,1	± 0,1	- 1,35	- 5,35
25	+ 3,1	± 0,1	- 1,35	- 5,35

Table B.3: Attenuation points distant from the carrier

Channel separation (kHz)	Tolerance range (kHz)			
	D1	D2	D3	D4
12,5	± 2,0	± 2,0	± 2,0	+ 2,0 - 6,0
20	± 3,0	± 3,0	± 3,0	+ 3,0 - 7,0
25	± 3,5	± 3,5	± 3,5	+ 3,5 - 7,5

The minimum attenuation of the filter outside the 90 dB attenuation points shall be ≥ 90 dB.

Table B.4: Frequency displacement

Channel separation (kHz)	Specified necessary bandwidth (kHz)	Displacement from the - 6 dB point (kHz)
12,5	8,5	8,25
20	14	13
25	16	17

The tuning of the power measuring receiver shall be adjusted away from the carrier so that the - 6 dB response nearest to the transmitter carrier frequency is located at a displacement from the nominal carrier frequency as given in table B.4.

B.1.3 Oscillator and amplifier

The measurement of the reference frequencies and the setting of the local oscillator frequency shall be within ± 50 Hz.

The mixer, oscillator and the amplifier shall be designed in such a way that the measurement of the adjacent channel power of an unmodulated test signal source, whose noise has a negligible influence on the measurement result, yields a measured value of ≤ -90 dB for channel separation of 20 and 25 kHz and of ≤ -80 dB for a channel separation of 12,5 kHz referred to the level of the test signal source.

The linearity of the amplifier shall be such that an error in the reading of no more than 1,5 dB is obtained over an input level variation of 100 dB.

B.1.4 Attenuation indicator

The attenuation indicator shall have a minimum range of 80 dB and a resolution of 1 dB.

B.1.5 Level indicators

Two level indicators are required to cover the rms and the peak transient measurement.

B.1.5.1 RMS level indicator

The rms level indicator shall accurately indicate non-sinusoidal signals within a ratio of 10:1 between peak value and rms value.

B.1.5.2 Peak level indicator

The peak level indicator shall accurately indicate and store the peak power level. For the transient power measurement the indicator bandwidth shall be greater than twice the channel separation.

A storage oscilloscope or a spectrum analyser may be used as a peak level indicator.

B.2 Spectrum analyser specification

The specification shall include the following requirements.

It shall be possible, using a resolution bandwidth of 1 kHz, to measure the amplitude of a signal, or noise at a level 3 dB or more above the noise level of the spectrum analyser, as displayed on the screen, to an accuracy of ± 2 dB in the presence of the wanted signal.

The accuracy of relative amplitude measurements shall be within ± 1 dB.

For statistically distributed modulations, the spectrum analyser and the integrating device (when appropriate) shall allow determination of the real spectral power density (energy per time and bandwidth), integrated over the bandwidth in question.

NOTE: This point should be considered very carefully.

B.3 Integrating and power summing device

The integrating and power summing device is connected to the video output of the spectrum analyser, referred to in clause B.2.

It shall be possible to sum the effective power of all discrete components, the spectral power density and the noise power in the selected bandwidth and to measure this as a ratio relative to the carrier power.

The position and the width of the integration range selected can be indicated on the spectrum analyser by brightening the trace.

Annex C (normative): Identification

The requirements set out in this annex are optional. This annex presents the technical characteristics to be fulfilled, when required by the appropriate national regulatory authority, for the identification of stations type approved for private mobile radio systems, that do not comply with other system protocols (e.g. trunking protocols); it is the responsibility of the manufacturer to ensure that the modulation that he has chosen for the identification, in accordance with the tables of this annex fulfils the requirements corresponding to the channels where the equipment is designed to operate, as specified in the main body of this ETS. The tables of this annex are expected to be updated regularly in order to reflect the progress accomplished in the field of mobile data transmissions.

C.1 Scope

The identification code shall fulfil the specifications given in this annex unless identification is included in a system protocol approved by the appropriate administration. It shall also be used by combined analogue/digital equipment in the case of analogue transmissions.

C.2 General

The design of a mobile system depends upon the requirements of that system, the evolution of technology and the specific needs and/or requirements of each country. When possible, the identification code would use the same techniques as the transmission of the user information itself. Therefore, a variety of possibilities have been presented in this annex. They are presented using several item tables and/or cross-tables:

- modulation, (indicating speed, channel separation and modulation): table C.1;
- bit sync (if needed) and synchronisation word: table C.2;
- redundancy code and length of the useful bits protected by that code (CRC): table C.3;
- header of the ID (length and contents shall be unique to avoid ambiguous situations): table C.4;
- country code and length of national information: table C.5;
- national information subdivided in fields: table C.6 (table C.7 and figures C.2 to C.6);
- combinations of the previous items that could be used: table C.8;
- combinations that will in fact be used in the various countries: table C.9;
- organisation of the fields that will in fact be used in the various countries: table C.10.

These tables can be used by manufacturers for the design of the equipment, for the type approval of the equipment and by the monitoring stations for the analysis of the identification of the transmissions.

C.3 Position of the identification code

Considering that a receiver in the monitoring service is often operated in scanning mode and stops on a detected carrier, the identification code is transmitted as described below.

C.3.1 Base stations

For base stations the identification ID shall be transmitted at the beginning and end of each session, at the end of the corresponding packets. If the session lasts for more than 3 minutes, an ID will also be transmitted at the end of the first transmitted packet after the 3 minutes has elapsed since the last transmission of the ID ("the 3 minutes rule"). There is no need for more than one ID per packet, unless 3 minutes have elapsed since the last transmission of the ID.

C.3.1.1 System without windows

In the case of continuous transmissions, the 3 minutes rule shall apply (not more than 3 minutes between transmissions of the ID).

C.3.1.2 Systems with windows

In the case of windows of less than 3 minutes, the ID shall also be sent at the end of the first packet of each window.

In the case of windows of more than 3 minutes, the ID shall, in addition, be sent according to the "3 minutes rule".

C.3.2 Handportable and mobile stations

The same rule as for the base stations applies except that a handportable or a mobile only transmitting to a base station (BS) with a transmission shorter than 300 ms (e.g. the duration of a data burst), does not have to transmit its ID systematically in each session. Instead, the 3 minute rule applies, as follows:

- the ID shall be sent at the end of the first packet to be sent after 3 minutes have elapsed since the last transmission of the ID.

C.4 Bit rates and modulations

Using the following table, demodulation can be performed, producing a bit stream. In the case of sub-carrier modulation (indirect modulation), the carrier can be modulated in phase (/ph.) or frequency (/frq.).

Table C.1: Bit rate and modulation schemes

Name	Bit Rate (b/s)	Channel separation (kHz)	Modulation (or reference)	Details (or reference)
MM12n /ph. /frq.	1 200	12,5	MSK (FFSK)	0 = 1 800 Hz, 1 = 1 200 Hz
MM12w /ph. /frq.	1 200	20 / 25	MSK (FFSK)	0 = 1 800 Hz, 1 = 1 200 Hz
MV22w	1 200	20 / 25	CCITT V 22	4 phase state
MV23w	1 200	20 / 25	CCITT V 23	0 = 2 100 Hz, 1 = 1 300 Hz
MM24n	2 400	12,5	MSK (FFSK)	0 = 2 400 Hz, 1 = 1 200 Hz
MM24w	2 400	20 / 25	MSK (FFSK)	0 = 2 400 Hz, 1 = 1 200 Hz
MD24n	2 400	12,5	Direct	
MD24w	2 400	20 / 25	Direct	
MM36n	3 600	12,5	MSK (FFSK)	0 = 3 600 Hz, 1 = 1 800 Hz
MM36w	3 600	20 / 25	MSK (FFSK)	0 = 3 600 Hz, 1 = 1 800 Hz
MD36n	3 600	12,5	Direct	
MD36w	3 600	20 / 25	Direct	
MM48n	4 800	12,5	MSK (FFSK)	0 = 4 800 Hz, 1 = 2 400 Hz
MM48w	4 800	20 / 25	MSK (FFSK)	0 = 4 800 Hz, 1 = 2 400 Hz
MD48n	4 800	12,5	Direct	
MD48w	4 800	20 / 25	Direct	
MD72n	7 200	12,5	Direct	
MD72w	7 200	20 / 25	Direct	
MD80n	8 000	12,5	Direct	
MD80w	8 000	20 / 25	Direct	
MD96n	9 600	12,5	Direct	
MD96w	9 600	20 / 25	Direct	
MD160	16 000	(20) / 25	Direct	
MD192	19 200	25	Direct	
NOTE 1:	The direct modulation concerns only constant envelope modulation methods and includes: GMSK, generalised tamed FM, multilevel state FM, PLL-4-PSK, 8 PSK.			
NOTE 2:	Other modulation systems are under consideration and may be added later to this table if proven to provide better performance.			
NOTE 3:	The frequency shift used with the direct FSK modulation should be chosen to meet subclause 8.3 (adjacent channel transmitter power).			
NOTE 4:	Some modulation methods presented in this table have not yet been proven to meet subclause 8.3 (adjacent channel transmitter power).			

C.5 Format of the identification

The identification (ID) shall be transmitted in one block (see definitions in subclause 3.1).

If bit rate/modulation of the users information and of the "ID" block are not the same, the block shall be preceded by "bit sync". If bit rate and modulation are the same, the "bit sync" is optional. However, it is well known that the auto-correlation properties of the "sync word" are calculated with respect to their corresponding "bit sync" (table C.2).

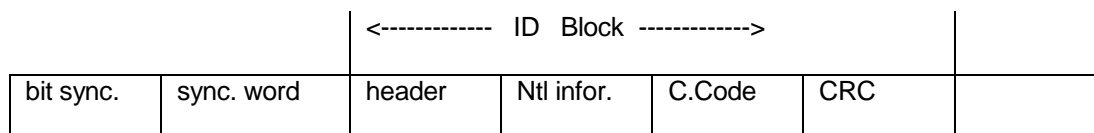

Figure C.1: ID block organisation

C.6 Synchronisation

Using table C.2, the monitoring station receiver/decoder can be synchronised (detection of the beginning of each block) and bits can be extracted from the bit stream. Bits shall be transmitted in the order of Most Significant Bit (MSB) first.

Table C.2: Synchronisation

bit sync (if needed)	Sync. word		Notes
	name	value	
1010 1010 1010 1010	S1	1011 0100 0011 0011	Note 1
1010 1010 1010 1010	S2	0011 1011 0010 1000	
10 10 10 10	S3	1100 1110 00	Note 2
01 01 01 01	S3'	0011 0001 11	Note 3
1010 1010 1010 1010	S4	1100 0100 1101 0111	
1010 1010 1010 1010	S5	(1)010 0010 1111 0111	
	S6	(1)101 1101 0000 1000	
1010 1010 1010 1010	S7	1010 1111 0001 0010	
NOTE 1: This sync word has optimal autocorrelation properties.			
NOTE 2: Frame synchronisation comprises 10 bits with the structure: S3 = transmissions Base to Handportable/Mobile; S3' = transmissions Handportable/Mobile to Base.			

Only these 10 bits are used for frame synchronisation when handportables or mobiles evaluate base stations.

These 10 bits plus base identity (10 bits) in the scheme apply to all other communication with the current base as synchronisation word for frame synchronisation. Furthermore, four control flags are included in the synchronisation word, i.e. the total length of the frame head is: 24 bits + bit sync.

C.7 Code and block length

Using table C.3, the "useful" bits of each block can be counted and checked (error detection can be performed). Corrections could also be performed: a trade-off between detection and correction performance and notes concerning the code are proposed in column Det/Corr.

Table C.3: Code and block length

Name	Sizes	Notes	Details	Det/Corr
C1	(64,48)		$X^{15}+X^{14}+X^{13}+X^{11}+X^4+X^2+1$ cyclic (63,48), LSB inv. +1 parity (even) bit appended	Det =< 5 errors
C2	(n+8,n)		$X^8+X^7+X^4+1$ all bits	
C3	(69,48)		Shortened cyclic	Det/Corr
C4	(16,8)	Note 1	Block code: Corr 2 er.	
OC1	16*(8,4)	Note 2	for "overcoding" the block in certain frequency bands parity check matrix: (01 -- -- --) (10 01 -- --) (10 10 01 --) (00 10 10 01)	Corr 2 err.
NOTE 1: Code C4 may be used in systems which need high protection and with a small amount of data to be transferred in a normal transmission. (6 blocks are needed to transmit the ID).				
NOTE 2: Code OC1, in some frequency bands, may be used to protect all the bits of the block (in order to allow the correction of errors due to ignition noise, etc.). In the case where the code OC1 is used, the code C1 should only be used for error detection.				

C.8 Contents of the identification block

C.8.1 Header

Using table C.4, the nature of the information contained in the block can be determined: ID or users/system information. Many of the combinations in this header are free for other use. Using such an organisation could allow countries using only one block for the ID to use only first bit as ID (users/system) information flag, while leaving it open for other countries to use more bits. These bits could also be considered as part of the sync word for hunting purposes.

Table C.4: Header information

Name	Length	Binary	Interpretation
H1	4 bits	Hn2 = 0 0 x x	ID word to be used during the session (monitored on F1 or F2)
		Hn1 = 0 1 x x	ID word transmitting on F1; it can be used to activate the corresponding repeater
		Hd = 1 y x x	user/system information block; bits y and x are free for future use or for transmitting user/system information
NOTE: When a repeater is used, "F1" is the frequency used for the handportables and mobiles to transmit, "F2" is the output frequency of the repeater.			

C.8.2 Country code

Table C.5 allows for the transcoding of the 5 bit OC field into the actual country where the ID has been allocated.

Table C.5: Country codes

Country code	Country	Length of Ntl info (if deviating from 39 bits) (subclauseC.8.3)
00 000	Nil	
01 111	Germany (Fed. Rep.)	41 bits
01 110	Andorra	
11 001	Austria	
01 100	Belgium	
00 100	Cyprus	
00 011	Czechoslovakia	
01 000	Denmark	
10 111	Spain	
01 011	Finland	
10 000	France	
00 111	Greece	
11 110	Ireland	
11 000	Iceland	
11 011	Liechtenstein	
11 011	Luxembourg	
11 101	Malta	
11 111	Monaco	
01 101	Norway	
10 001	Netherlands	
10 101	Poland	
00 010	Portugal	
01 001	United Kingdom	
10 110	San Marino	
10 010	Sweden	
00 101	Switzerland	
11 100	Turkey	
00 001	Vatican (City)	
10 100	Yugoslavia	
NOTE 1:	In the allocation some codes are missing due to recent developments in Europe; this table will be completed when possible in the future.	
NOTE 2:	Two or more countries can use the same 5 bit CC code in which case the differentiation can be made using the LOF field ("Regional Licensing Office).	
NOTE 3:	When mobiles from two or more countries are not expected to interfere with each other, then these countries can use the same 5 bit CC code.	

C.8.3 National Information

The following options for the fields containing the "National" (Ntl) information are based on the assumption that the ID blocks contain 48 useful bits and provide 39 bits for the "National" information field (field Ntl info).

C.8.3.1 Field description

The following fields can either be used for the purpose of identification and/or used for transmitting information corresponding to user data or system needs:

Table C.6: Field description

Category	No of bits
Licensee number	Lnb: 0 - 14
Individual transmitter identification	TID: 0 - 20
Network identification	NID:14 - 20
Regional licensing office	LOF: 0 - 8
Relay station number	Rnb: 0 - 12
National Additional information	NAI: 0 - 20
User group	UG : 0 - 7
Field free for system or user data	FF :

The maximum total number of bits available in field F is 39 bits (however national information can go up to 41 bits by overflow of 2 bits into the header Hxx bits).

All categories are expected to be coded in binary (and will be presented in 4 bit nibbles).

C.8.3.2 Field size options

Table C.7: Field size options

Name of the scheme	Field description		
	Size	Name	Usage
FZ1	7 bits	LOF	regional licensing office ID
	7 bits	UG	user group
	14 bits	NID	network identification
	13 bits	TID	individual transmitter ID
FZ2	5 bits	Rnb	relay number
	18 bits	NID	network ID
	12 bits	TID	individual mobile number
FZ3	27 bits	Lnb	licensee number
	14 bits	NID	network ID

C.8.3.3 Options for the organisation of the fields

bit	0	2	9	13	16	30	43
sync word	H Oy	UG 7 bits	LOFM 4 bits	LOFL 3 bits	NID 14 bits	TID 13 bits	CC 5 bits

Figure C.2: FO1

bit	0	4	9	13	31	43
sync word	H Oyxx	Rnb 5 bits	FF 4 bits	NID 18 bits	TID 12 bits	CC 5 bits

Figure C.3: FO2

bit	0	2	29	43
sync word	H Oy	Lnb 27 bits	NID 14 bits	CC 5 bits

Figure C.4: FO3

bit	0	4	9	36	43
sync word	H Obxx	FF 5 bits	Lnb 27 bits	NID 7 bits	CC 5 bits

Figure C.5: FO3b

bit	0	4	9	13	17	31	43
sync word	H Obxx	Rnb 5 bits	FF 4 bits	Ext 4 bits	NID 14 bits	TID 12 bits	CC 5 bits

Figure C.6: F04

Option F04, given in figure C.6 above, is a common representation where the extension (4 bits) could be either FF or LOFL or an extension for NID.

NOTE: "bit", in these tables, means the first bit of the corresponding field.

C.8.3.4 Examples of user/system information usage

The bits of the ID block that have not been allocated in table C.6 (free fields "FF") can be:

- used for numbering the blocks in the packets (e.g. 3 bits);
- used as a function code (e.g. 2 bits);
- used for the transmission of status;
- used to transmit an acknowledge;
- used to transmit a no-acknowledge;
- used to clear down the repeater (deactivation of the repeater after an activation using, for instance, Header code Hn1).

C.9 Combinations

Tables C.8 and C.9 indicate which of the combinations given in the "Items Tables" will in fact be used.

C.9.1 List of possible combinations

Table C.8 indicates the "lower layer" combinations that have been explicitly supported by the regulatory authorities and that could be accepted in some countries. Knowing these formats and codes, NTL information can be easily accessed.

Table C.8: Combinations table

modulation	sync. word	code length	Header	Freq.Band	comb. name + notes
MM12w	S1	C1	H1(w/2bit)		ACx
MM12n	S1	C1	H1	< 500 MHz	ACy
MM12n,w	S3 + S3'	C3	H1	< 1000 MHz	ACzn,ACzw
MM12n,w	S7	C4	H1	< 500 MHz	ACtn,ACtw

NOTE: To be completed in the future.

C.9.2 Relations between country code and allowed combinations

The following table indicates, among the combinations included in table C.8, those which are, or will soon be, effectively allowed in the different countries.

Table C.9: Combinations in a country

Country code	Allowed combinations	Notes
D 01 111	ACx, Fs	Not all combinations will be allowed
And 01 110		
A 11 001		
B 01 100		
CY 00 100		
DK 01 000	Fs	
E 10 111	Fs	
SF 01 011	Fs	
F 10 000	ACy	Until further notice, only one is allowed
GR 00 111		
IRL 11 110		
IS 11 000		
I 01 010	Fs	
FL 11 010	Fs	
L 11 011		
M 11 101		
MC 11 111		
N 01 101	Fs	
NL 10 001	Fs	In the future only a few combinations will be allowed
P 00 010	Fs	
GB 01 001	ACy	Other combinations may be allowed
SMR 10 110		
S 10 010	ACzw, ACtw	Other combinations may be allowed
CH 00 101	Fs	
TR 11 100		
SCV 00 001		
YU 10 100		
NOTE: Fs: further study is needed.		

C.9.3 Interpretation of the fields of the ID block

Using table C.10, interpretation of the various fields could be performed.

Table C.10: Interpretation table

Country code	Scheme for organisation of NTL info (NOTE 2)
D 01 111	Z1 / F01
And 01 110	
A 11 001	
B 01 100	
CY 00 100	
DK 01 000	Fs (note 1)
E 10 111	Fs
SF 01 011	Fs
F 10 000	FZ2 / F02, equivalent to F04 with EXT used for extension of NID
GR 00 111	
IRL 11 110	
IS 11 000	
I 01 010	Fs
FL 11 010	Fs
L 11 011	
M 11 101	
MC 11 111	
N 01 101	
NL 10 001	
P 00 010	
GB 01 001	
SMR 10 110	
S 10 010	Fs
CH 00 101	Fs
TR 11 100	
SCV 00 001	
YU 10 100	
NOTE 1:	Fs: further study is needed.
NOTE 2:	For NTL information see subclause D.8.3, including tables D.6 and D.7 and figures D.2 to D.6.

Annex D (informative): Graphic representation of selection of equipment and frequencies for testing

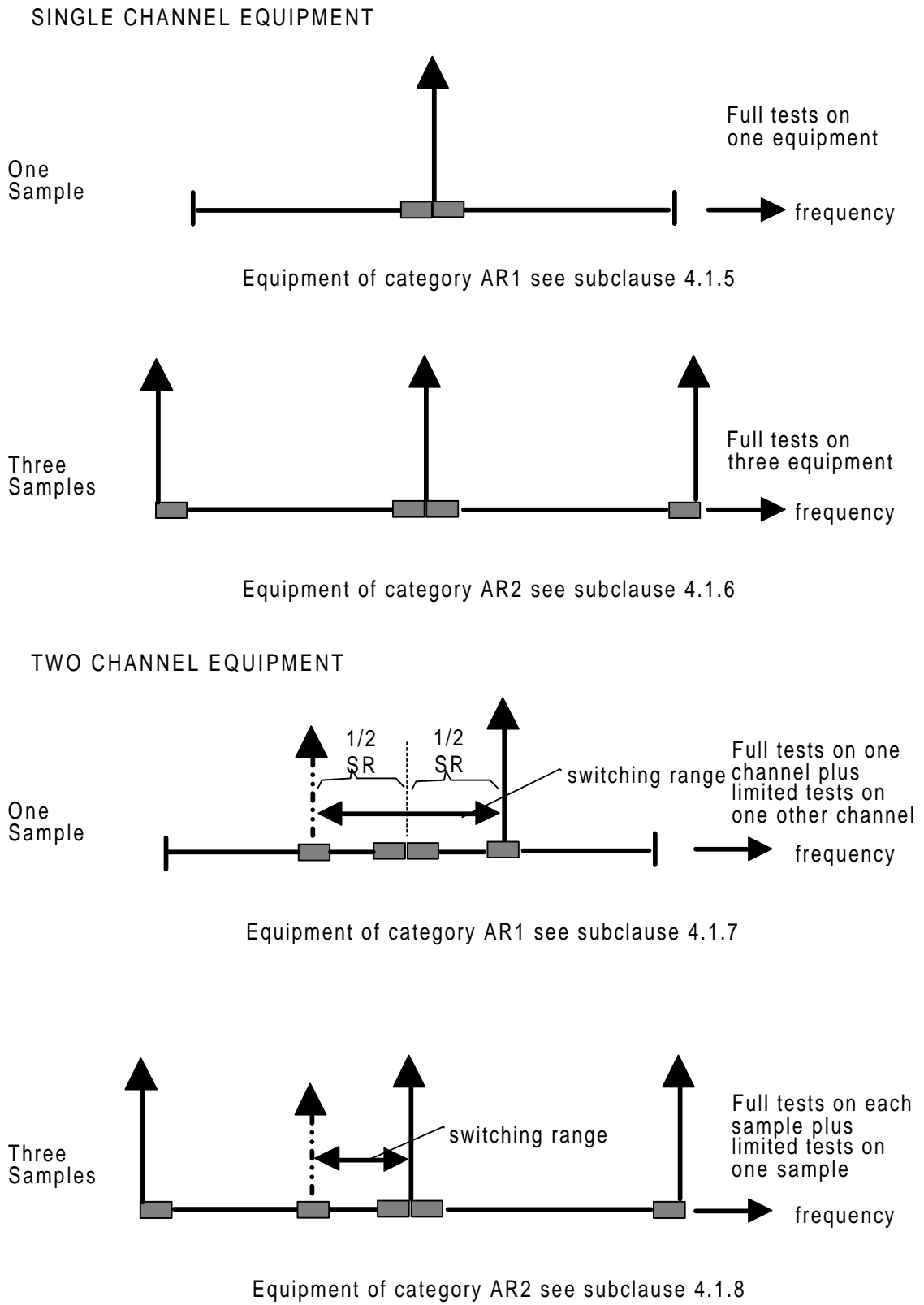

NOTE: for legend see figure D.2

Figure D.1: Single channel/two channel equipment

MULTI CHANNEL EQUIPMENT

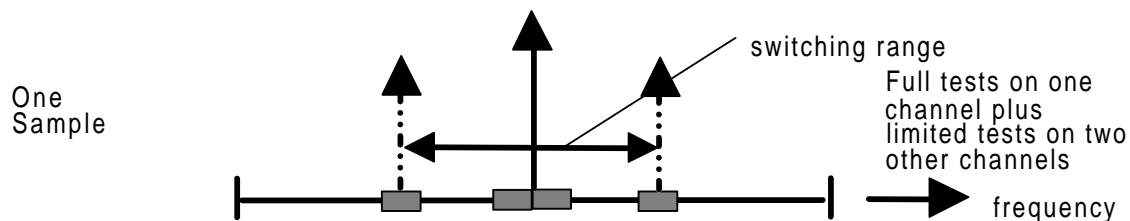

Equipment of category AR1 see subclause 4.1.9

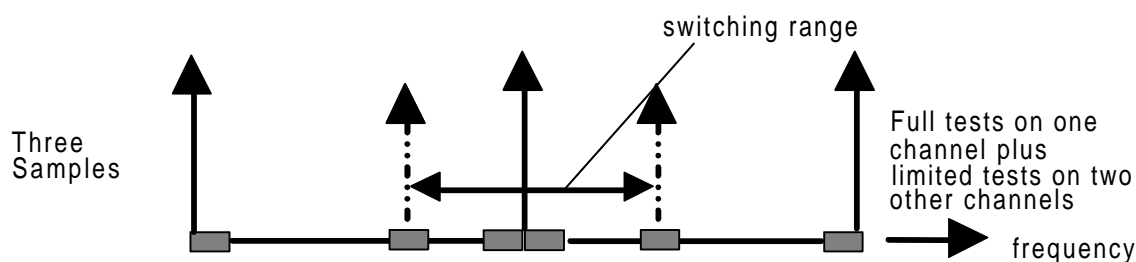

Equipment of category AR2 see subclause 4.1.10

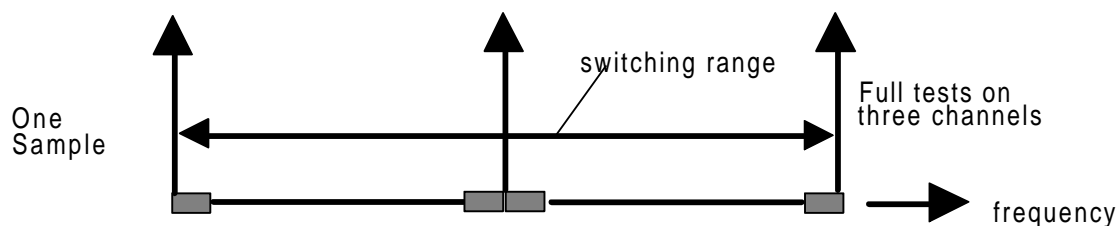

Equipment of category AR2 see subclause 4.1.11
 AR = SR

Legend:

AR1 - First category of alignment range, see subclause 4.1.3.

AR2 - Second category of alignment range, see subclause 4.1.3.

Limited test, see subclause 3.1.

Full test, see subclause 3.1.

100 kHz range in which the test shall be carried out.

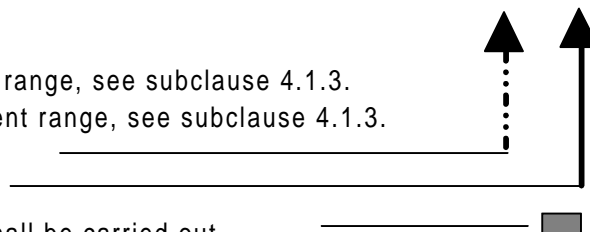

Figure D.2: Multichannel equipment

Annex E (informative): Information on modulation, coding and format

It is pointed out that this ETS addresses only the minimum performance of the hardware/lower layers of the data equipment and that it does not cover measurements that confirm the error ratio performance of the radio data systems in real or simulated mobile environment conditions (multipath fading, burst interference, ignition noise etc.).

Attention is drawn to the fact that CCITT Recommendations do not address the mobile system error ratio issue. Therefore, equipment designed to meet such recommendations is not necessarily suitable for use in mobile radio systems. Specifically external modems, protocols and also ancillary units used in conjunction with mobile radio equipment should be capable of operating with the mobile radio system in such a manner as to minimise the system error ratio in real conditions, and to provide good spectrum efficiency.

Attention is also drawn to the availability of CCIR Recommendations and reports on the subject.

Furthermore, it is recommended to obtain the approval of the mobile radio manufacturer of any equipment to be incorporated in a mobile radio data system (e.g. in "OEM" basis).

Annex F (informative): Bibliography

- IEC 489-3 Second edition (1988), "Methods of measurement for radio equipment used in the mobile services; Part 3: Receivers for A3E or F3E emissions", Appendix F pages 130 to 133 and Appendix J pages 156 to 164.
- "Construction of a Stripline", Technical Report FTZ 512 TB 9.
- Ketterling, H-P: "Verification of the performance of fully and semi-anechoic chambers for radiation measurements and susceptibility/immunity testing", 1991, Leatherhead/Surrey.
- COST 207 final report, Brussels 1989.

History

Document history			
February 1994	Public Enquiry	PE 57:	1994-02-21 to 1994-06-17
September 1995	Vote	V 87:	1995-09-11 to 1995-11-03
February 1996	First Edition		