



**E**UROPEAN  
**T**ELECOMMUNICATION  
**S**TANDARD

**DRAFT**  
pr **ETS 300 370**

August 1996

Second Edition

---

Source: ETSI TC-RES

Reference: RE/RES-03073

ICS: 33.020, 33.060.50

**Key words:** DECT, GSM

**Radio Equipment and Systems (RES);  
Digital Enhanced Cordless Telecommunications /  
Global System for Mobile communications (DECT/GSM);  
DECT/GSM interworking profile;  
Access and mapping  
(protocol/procedure description for 3,1 kHz speech service)**

**ETSI**

European Telecommunications Standards Institute

**ETSI Secretariat**

**Postal address:** F-06921 Sophia Antipolis CEDEX - FRANCE

**Office address:** 650 Route des Lucioles - Sophia Antipolis - Valbonne - FRANCE

**X.400:** c=fr, a=atlas, p=etsi, s=secretariat - **Internet:** secretariat@etsi.fr

Tel.: +33 92 94 42 00 - Fax: +33 93 65 47 16

---

**Copyright Notification:** No part may be reproduced except as authorized by written permission. The copyright and the foregoing restriction extend to reproduction in all media.

© European Telecommunications Standards Institute 1996. All rights reserved.



## Contents

Foreword .....	9
Introduction .....	9
1 Scope .....	11
2 Normative references .....	11
3 Definitions, abbreviations and symbols .....	14
3.1 DECT definitions .....	14
3.2 Abbreviations .....	17
3.3 GSM abbreviations and definitions .....	18
3.4 Symbols for status columns .....	18
4 General .....	18
5 Interworking requirements .....	19
5.1 General .....	19
5.2 Reference configurations .....	19
5.2.1 FP functional attachment to the GSM PLMN .....	19
5.3 General interworking model for FP GSM PLMN attachment .....	20
5.4 Interworking context .....	20
5.4.1 General .....	20
5.4.2 Basic interworking rules .....	21
5.4.3 Location area mapping .....	22
5.4.4 Interpretation of broadcast attributes .....	23
6 Interworking mappings, FP attached to the GSM PLMN .....	24
6.1 FP C-Plane IWU procedures .....	24
6.1.1 Call handling IWU procedures .....	24
6.1.1.1 Normal outgoing call .....	24
6.1.1.2 Emergency call .....	27
6.1.1.3 Incoming call .....	28
6.1.1.4 Normal call release initiated by the PP .....	30
6.1.1.5 Normal call release initiated by the GSM PLMN .....	30
6.1.1.6 Abnormal call release initiated by the PP .....	32
6.1.1.7 Abnormal call release initiated by the GSM network .....	33
6.1.1.8 Exceptional cases .....	33
6.1.1.9 Other .....	33
6.1.2 Other IWU procedures .....	34
6.1.2.1 Authentication procedure .....	35
6.1.2.2 Identity procedure .....	36
6.1.2.3 Location registration related procedures .....	36
6.1.2.4 Detach procedure .....	40
6.1.2.5 Temporary identity assignment procedures .....	40
6.1.2.6 Ciphering procedure .....	42
6.1.2.7 CM service procedure .....	43
6.1.2.8 CM service procedure abnormal cases .....	46
6.1.2.9 External handover procedure .....	46
6.1.2.9.1 General description .....	46
6.1.2.9.2 Handover candidate procedure .....	47
6.1.2.9.3 Handover required indication .....	47
6.1.2.9.4 Handover resource allocation .....	47
6.1.2.9.5 Handover execution by FP .....	48
6.1.2.9.5.1 Handover request to FP-2 .....	48
6.1.2.9.5.2 Handover confirm by FP-2 .....	48
6.1.2.9.5.3 Ciphering procedure .....	48

	6.1.2.9.5.4	Handover completion .....	49
	6.1.2.9.5.5	Sequence number handling .....	50
	6.1.2.9.6	Handover reject .....	50
	6.1.2.9.6.1	Handover reject by PP .....	50
	6.1.2.9.6.2	Handover reject by FP-1 .....	50
	6.1.2.9.6.3	Handover reject by FP-2 .....	50
	6.1.2.9.6.4	Handover reject by MSC .....	50
	6.1.2.9.7	Support of external handover due to O&M activities .....	51
	6.1.2.9.8	Handling of transaction identifiers during and after external handover .....	51
6.1.3		Paging related IWU procedure .....	51
6.1.4		Other specific IWU procedures .....	52
	6.1.4.1	Equipment identity IWU procedures .....	52
	6.1.4.2	Miscellaneous procedures .....	52
	6.1.4.2.1	Notification of progress and interworking .....	52
	6.1.4.2.2	User notification .....	53
	6.1.4.3	Handling of Dual Tone Multi-Frequency (DTMF) .....	53
6.1.5		Exception handling .....	55
	6.1.5.1	Error handling .....	55
	6.1.5.2	Timers .....	55
	6.1.5.2.1	Call handling IWU procedures .....	55
	6.1.5.2.2	Other IWU procedures and paging procedures .....	55
6.1.6		Message mappings .....	56
	6.1.6.1	GSM to DECT .....	56
	6.1.6.1.1	AUTHENTICATION REQUEST- {AUTHENTICATION-REQUEST} .....	57
	6.1.6.1.2	AUTHENTICATION REJECT- {MM- INFO-SUGGEST} .....	57
	6.1.6.1.3	IDENTITY-REQUEST - {IDENTITY- REQUEST} .....	57
	6.1.6.1.4	TMSI REALLOCATION COMMAND - {TEMPORARY-IDENTITY-ASSIGN} .....	58
	6.1.6.1.5	CIPHERING MODE COMMAND - {CIPHER-REQUEST} .....	58
	6.1.6.1.6	LOCATION UPDATING ACCEPT - {LOCATE-ACCEPT} .....	59
	6.1.6.1.7	LOCATION UPDATING REJECT - {LOCATE-REJECT} .....	59
	6.1.6.1.8	ALERTING - {CC-ALERTING} .....	59
	6.1.6.1.9	CALL-PROC - {CC-CALL-PROC} .....	60
	6.1.6.1.10	CONNECT - {CC-CONNECT} .....	60
	6.1.6.1.11	SETUP - {CC-SETUP} .....	60
	6.1.6.1.12	DISCONNECT - {CC-RELEASE} .....	61
	6.1.6.1.13	RELEASE - {CC-RELEASE-COM} .....	61
	6.1.6.1.14	RELEASE COMPLETE - CC- RELEASE-COM .....	61
	6.1.6.1.15	CM SERVICE REJECT - {CC- RELEASE-COM} .....	62
	6.1.6.1.16	ABORT - {CC-RELEASE-COM} .....	62
	6.1.6.1.17	CONNECT-ACK to {CC-CONNECT- ACK} .....	62
	6.1.6.1.18	PROGRESS - {CC-INFO} .....	62
	6.1.6.1.19	PROGRESS - {CC-NOTIFY} .....	63
	6.1.6.1.20	DISCONNECT - {CC-INFO} .....	63
	6.1.6.1.21	RELEASE - {CC-RELEASE} .....	63
	6.1.6.1.22	START-DTMF-ACK - {CC-INFO} .....	64
	6.1.6.1.23	START-DTMF-REJECT - {CC-INFO} ..	64
	6.1.6.1.24	STOP-DTMF-ACK - {CC-INFO} .....	64
	6.1.6.1.25	CM SERVICE ACCEPT - {CC- SETUP-ACK} .....	64

	6.1.6.1.26	Handover Command - {MM-INFO-ACCEPT} .....	65
	6.1.6.1.27	Clear Command - {CC-RELEASE} .....	65
	6.1.6.1.28	Handover Required Reject - {MM-INFO-REJECT} .....	65
	6.1.6.1.29	Handover Command - {MM-INFO-SUGGEST} .....	66
	6.1.6.1.30	NOTIFY - {CC-INFO} .....	66
6.1.6.2	DECT to GSM .....		67
	6.1.6.2.1	{LOCATE-REQUEST} - LOCATION-UPDATING-REQUEST .....	68
	6.1.6.2.2	{LCE-PAGE-RESPONSE} - PAGING RESPONSE .....	69
	6.1.6.2.3	{AUTHENTICATION-REPLY} - AUTHENTICATION RESPONSE .....	69
	6.1.6.2.4	{DETACH} - IMSI DETACH INDICATION .....	70
	6.1.6.2.5	{TEMPORARY-IDENTITY-ASSIGN-ACK} - TMSI REALLOCATION COMPLETE .....	70
	6.1.6.2.6	{CC-SETUP} - CM SERVICE REQUEST .....	70
	6.1.6.2.7	{IDENTITY-REPLY} - IDENTITY RESPONSE .....	71
	6.1.6.2.8	{CC-ALERTING} - ALERTING .....	71
	6.1.6.2.9	{CC-CONNECT} - CONNECT .....	72
	6.1.6.2.10	{CC-INFO} (F-02) - SETUP .....	72
	6.1.6.2.11	{CC-RELEASE} - DISCONNECT .....	73
	6.1.6.2.12	{CC-RELEASE} - RELEASE .....	73
	6.1.6.2.13	CC-RELEASE-COM - RELEASE .....	73
	6.1.6.2.14	{CC-RELEASE-COM} - RELEASE-COMplete .....	74
	6.1.6.2.15	{CC-SETUP} - SETUP .....	75
	6.1.6.2.16	{CC-SETUP} - EMERGENCY-SETUP .....	76
	6.1.6.2.17	{CC-RELEASE} - CM SERVICE ABORT .....	76
	6.1.6.2.18	{CC-INFO} - START-DTMF .....	77
	6.1.6.2.19	{CC-INFO} - STOP-DTMF .....	77
	6.1.6.2.20	{MM-INFO-REQUEST} - Handover required .....	77
	6.1.6.2.21	{CC-SETUP} - Handover detect .....	78
	6.1.6.2.22	{CC-CONNECT-ACK} - handover complete .....	78
	6.1.6.2.23	{MM-INFO-REQUEST} - handover failure .....	78
6.1.7	Information element mappings .....		79
	6.1.7.1	GSM to DECT .....	79
	6.1.7.1.1	Mobile identity - NWK assigned identity .....	79
	6.1.7.1.2	Authentication parameter RAND - RAND .....	79
	6.1.7.1.3	Cipher key sequence number - auth type .....	80
	6.1.7.1.4	Location area identification - location area .....	80
	6.1.7.1.5	Identity type - identity type .....	81
	6.1.7.1.6	Reject cause - reject reason .....	81
	6.1.7.1.7	Bearer capabilities 1 - basic service .....	81
	6.1.7.1.8	Progress indicator - progress indicator .....	81
	6.1.7.1.9	Cause - release reason .....	82
	6.1.7.1.10	Reject cause - release reason .....	82
	6.1.7.1.11	Signal - signal .....	82
	6.1.7.1.12	Keypad facility - multi display .....	82

	6.1.7.1.13	Cause - multi display .....	83
	6.1.7.1.14	Layer 3 information - fixed identity .....	83
	6.1.7.1.15	Layer 3 information - network parameter .....	84
	6.1.7.1.16	Notification indicator - multi display .....	84
6.1.7.2	DECT to GSM .....		85
	6.1.7.2.1	Portable identity - mobile identity .....	85
	6.1.7.2.2	Network assigned identity- mobile identity .....	85
	6.1.7.2.3	Location area - location area identification .....	85
	6.1.7.2.4	Cipher info - cipher key sequence number .....	86
	6.1.7.2.5	RES - Auth. parameter SRES .....	86
	6.1.7.2.6	Portable identity- mobile identity .....	86
	6.1.7.2.7	Basic service - CM service type .....	87
	6.1.7.2.8	Basic service - bearer capabilities .....	87
	6.1.7.2.9	Called-party-number - called-party- number .....	87
	6.1.7.2.10	Multi keypad - called-party-number .....	88
	6.1.7.2.11	Multi keypad - keypad facility (F-10) .....	88
	6.1.7.2.12	Release reason - cause .....	88
	6.1.7.2.13	Info type - cause .....	89
6.1.8	Fields in information element coding .....		89
	6.1.8.1	GSM to DECT .....	89
	6.1.8.1.1	Protocol discriminator - protocol discriminator .....	89
	6.1.8.1.2	Transaction identifier - transaction identifier .....	90
	6.1.8.1.3	Message type - message type .....	90
	6.1.8.1.4	Id for info element (IEI) - id for info element .....	90
	6.1.8.1.5	Length of contents - length of contents	90
	6.1.8.1.6	Type, (Mobile identity, NWK assigned identity) .....	90
	6.1.8.1.7	Identity value, (mobile identity, NWK assigned identity) .....	91
	6.1.8.1.8	Y/N bit (encryption information - cipher info) .....	91
	6.1.8.1.9	RAND field (RAND - RAND) .....	91
	6.1.8.1.10	Cipher key number (key sequence - cipher key number) .....	91
	6.1.8.1.11	Extended location information (location area identification - location area) .....	92
	6.1.8.1.12	Identity group (identity type - identity type) .....	92
	6.1.8.1.13	Type (identity type - identity type) .....	92
	6.1.8.1.14	Type, (mobile identity, portable identity) .....	93
	6.1.8.1.15	Portable user type, (mobile identity, portable identity) .....	93
	6.1.8.1.16	Identity value, (mobile identity - portable identity) .....	93
	6.1.8.1.17	Reject cause value - reject reason code .....	93
	6.1.8.1.18	Coding-standard - coding-standard .....	94
	6.1.8.1.19	Information transfer capability - basic service .....	94
	6.1.8.1.20	Location - location .....	94
	6.1.8.1.21	Progress-description - progress- description .....	95
	6.1.8.1.22	Cause-value - release-reason-code .....	95

	6.1.8.1.23	Signal value - signal value .....	95
	6.1.8.1.24	Skip indicator - transaction identifier.....	96
	6.1.8.1.25	Reject cause value - release reason code .....	96
6.1.8.2	DECT to GSM.....		96
	6.1.8.2.1	Protocol discriminator -protocol discriminator .....	96
	6.1.8.2.2	Transaction identifier - transaction identifier .....	96
	6.1.8.2.3	Message type - message type .....	96
	6.1.8.2.4	Id for info element - id for info element (IEI) .....	96
	6.1.8.2.5	Length of contents - length of contents.	96
	6.1.8.2.6	Length of identity value (portable identity - mobile identity) .....	97
	6.1.8.2.7	Type, (portable identity - mobile identity) .....	97
	6.1.8.2.8	Portable user type, (portable identity - mobile identity).....	97
	6.1.8.2.9	Identity value, (portable identity - mobile identity).....	97
	6.1.8.2.10	Type, (NWK assigned identity - mobile identity) .....	97
	6.1.8.2.11	Identity value, (NWK assigned identity - mobile identity).....	98
	6.1.8.2.12	Extended location information, (location area - location area identification).....	98
	6.1.8.2.13	Cipher key number, (cipher info - cipher key sequence number) .....	98
	6.1.8.2.14	RES field (RES - auth. parameter SRES) .....	98
	6.1.8.2.15	Type, (portable identity - mobile identity) .....	99
	6.1.8.2.16	Call class, (basic service - CM service type) .....	99
	6.1.8.2.17	Basic service - information transfer capability .....	99
	6.1.8.2.18	Number-type - type-of-number .....	99
	6.1.8.2.19	Numbering-plan identification - numbering-plan identification .....	100
	6.1.8.2.20	Release-reason-code - cause-value...	100
	6.1.8.2.21	Transaction identifier - skip indicator ..	100
6.2	FP U-Plane IWU procedures .....		101
	6.2.1	Service activation .....	101
6.3	PP C-Plane IWU mappings .....		101
	6.3.1	Call handling IWU procedures .....	101
	6.3.1.1	Call establishment procedure .....	101
	6.3.1.1.1	Outgoing call .....	101
	6.3.1.1.2	Emergency call .....	101
	6.3.1.1.3	Incoming call .....	102
	6.3.1.2	Call release/reject procedures .....	102
	6.3.2	Other IWU procedures .....	102
	6.3.2.1	Authentication procedure .....	103
	6.3.2.2	Identity procedure .....	104
	6.3.2.3	Location registration procedure .....	104
	6.3.2.3.1	General .....	104
	6.3.2.3.2	Normal location updating .....	105
	6.3.2.3.3	Periodic location updating .....	105
	6.3.2.3.4	IMSI attach procedure .....	105
	6.3.2.3.5	Generic location updating procedure..	106
	6.3.2.3.5.1	Location updating initiation by the PP .	106
	6.3.2.3.5.2	Attempt counter .....	108

	6.3.2.3.5.3	Location updating not accepted by the network.....	108
	6.3.2.4	Detach procedure .....	109
	6.3.2.5	Temporary identity assignment procedure.....	109
	6.3.2.6	Ciphering related procedure.....	110
	6.3.2.7	External handover procedure.....	110
	6.3.2.7.1	Handover candidate procedure .....	110
	6.3.2.7.2	Handover reference retrieval.....	111
	6.3.2.7.3	Handover execution by PP.....	111
	6.3.2.7.4	Handover request.....	111
	6.3.2.7.4.1	Handover request to FP-2.....	111
	6.3.2.7.4.2	Handover accept by PP.....	111
	6.3.2.7.4.3	Ciphering procedure.....	112
	6.3.2.7.5	Release of old connection.....	112
	6.3.2.7.6	Handover reject.....	112
	6.3.2.7.7	Support of external handover due to O&M activities .....	112
	6.3.2.7.8	Handling of transaction identifiers during and after external handover ....	113
	6.3.3	Paging related IWU procedure .....	114
	6.3.4	Message mappings.....	115
	6.3.5	Information element mappings .....	115
	6.3.6	Stopping of CC timers.....	115
7		Interworking connection type definitions.....	116
Annex A (normative):		Derivation of the DECT ciphering key CK.....	117
A.1		Introduction .....	117
A.2		Algorithm to calculate the DECT CK from Kc.....	117
Annex B (normative):		Deletion of the GSM Kc, CKSN, TMSI and LAI .....	118
Annex C (normative):		Mapping of equipment identities .....	119
Annex D (informative):		Physical attachment models for the FP .....	120
D.1		Introduction .....	120
D.2		Physical attachment to the MSC.....	120
D.3		Physical attachment to the BSC .....	120
D.4		Physical attachment to the BTS.....	120
Annex E (informative):		Bibliography .....	121
History		.....	122



## Foreword

This draft 2nd edition European Telecommunication Standard (ETS) has been produced by the Radio Equipment and Systems (RES) Technical Committee of the European Telecommunications Standards Institute (ETSI), and is now submitted for the Public Enquiry phase of the ETSI standards approval procedure.

Proposed transposition dates	
Date of latest announcement of this ETS (doa):	3 months after ETSI publication
Date of latest publication of new National Standard or endorsement of this ETS (dop/e):	6 months after doa
Date of withdrawal of any conflicting National Standard (dow):	6 months after doa

## Introduction

This ETS is a part of a set of standards for the Digital Enhanced Cordless Telecommunications / Global System for Mobile communications (DECT/GSM) Interworking Profile (IWP) concept that includes:

- general description of service requirements, functional capabilities and information flows, ETS 300 466 [16];
- **access and mapping (protocol/procedure description for 3,1 kHz speech service), (this ETS);**
- GSM Phase 2 supplementary services implementation, ETS 300 703 [29];
- GSM Mobile Switching Centre (MSC) - DECT Fixed Part (FP), Fixed Interconnection, ETS 300 499 [28];
- implementation of bearer services, ETS 300 756 [30];
- implementation of short message services, point to point and cell broadcast, ETS 300 764 [27].
- implementation of facsimile group 3, (ETS 300 792 [33]).

This ETS is based on DECT Common Interface (CI) specification ETS 300 175 parts 1 to 8 [1] to [8] to enable DECT terminals to interwork in the public and private environment with DECT systems which are connected to a Global System for Mobile communications (GSM) core infrastructure.

In addition, this ETS is based on the DECT Generic Access Profile (ETS 300 444 [9] to enable the same DECT/GSM terminal to interwork with a DECT FP complying to the Generic Access Profile (GAP) requirements, irrespective of whether this FP provides residential, business or public access services. General attachment requirements and speech attachment requirements are based on TBR 6 [31] and TBR 10 [32].

This ETS utilises, in addition to the GAP only related features and procedures, the following:

- GSM authentication;
- derivation of the DECT ciphering key from the respective GSM cipher key;
- the GSM International Mobile Subscriber Identity (IMSI) and Temporary Mobile Subscriber Identity (TMSI);
- the GSM Location Area Identity (LAI).
- subscription management by use of SIM or DECT Authentication Module (DAM) GA; and
- adding/deleting a Public Land Mobile Network (PLMN) in the SIM/DAM GA forbidden PLMN list.

This ETS defines a general purpose, but strict, mobility profile in terms of features, procedures, data structures, information elements and fields within the information elements at the DECT air interface in order to achieve full inter-operability between equipment i.e. DECT systems and terminals, which fulfil the requirements of this ETS. This ETS also fulfils the minimum requirements of the GAP enabling backwards compatibility with the respective equipment.

Information on DECT access to the GSM PLMN may be found in ETR 159 [25]. Further details on the DECT system may be found in ETR 015 [13], ETR 043 [14], and ETR 056 [15], and in ETS 300 176 [11].

Blank page

## 1 Scope

This European Telecommunication Standard (ETS) specifies the Digital Enhanced Cordless Telecommunications (DECT) access protocols and Fixed Part (FP) and Portable Part (PP) interworking/mappings necessary to ensure that the Global System for Mobile communications (GSM) basic voice telephony service can be provided over DECT. To enable DECT terminals to interwork with DECT systems which are connected to the GSM infrastructure, from the DECT side this ETS is based on ETS 300 444 [9] and on the DECT Common Interface specification ETS 300 175 parts 1 to 8 [1] to [8] (for the cases not covered by Generic Access Profile (GAP)), from GSM side this ETS assumes interworking with GSM Public Land Mobile Network (PLMN) phase 2.

An air-interface profile is specified for a particular set of GSM services so that inter-operability of DECT equipment for these services can be achieved. Interworking functions/mappings are specified for Mobile Switching Centre (MSC) attachment for the DECT FP as the FP is using the A-interface towards the GSM MSC in the respect that the FP emulates a GSM Base Station Controller (BSC) with regards to the GSM messages which are relevant to this ETS. Interworking functions/mappings for the PP are specified for MSC environment.

The provision of the GSM Subscriber Identity Module (SIM) and DECT Authentication Module (DAM) with the GSM Application (GA) within the DECT portable are also considered.

This ETS covers a subset of ETS 300 557 [21] (GSM 04.08) and ETS 300 590 [23] (GSM 08.08) procedures as far as mapping is concerned and as far as this is required for support of 3,1 kHz speech service.

GSM functions of ETS 300 590 [23] (GSM 08.08) which, in a DECT/GSM context, are relevant at the A-interface only, are out of scope of this ETS, as well as interfaces to non GSM networks.

Specific interworking procedures/mappings for the support of supplementary services, data services, short message services and other GSM services are out scope of this ETS. Basic support for service initiation/invocation is however supported by this ETS.

A PP conforming to this ETS should be capable of distinguishing a FP conforming to this ETS from a FP conforming to the GAP and to access and react upon it accordingly.

## 2 Normative references

This ETS incorporates, by dated or undated reference, provisions from other publications. These normative references are cited at the appropriate places in the text and the publications are listed hereafter. For dated references, subsequent amendments to or revisions of any of these publications apply to this ETS only when incorporated in it by amendment or revision. For undated references the latest edition of the publication referred to applies.

- [1] ETS 300 175-1: "Radio Equipment and Systems (RES); Digital European Cordless Telecommunications (DECT); Common Interface (CI); Part 1: Overview".
- [2] ETS 300 175-2: "Radio Equipment and Systems (RES); Digital European Cordless Telecommunications (DECT); Common Interface (CI); Part 2: Physical Layer".
- [3] ETS 300 175-3: "Radio Equipment and Systems (RES); Digital European Cordless Telecommunications (DECT); Common Interface (CI); Part 3: Medium Access Control (MAC) layer".
- [4] ETS 300 175-4: "Radio Equipment and Systems (RES); Digital European Cordless Telecommunications (DECT); Common Interface (CI); Part 4: Data Link Control (DLC) layer".
- [5] ETS 300 175-5: "Radio Equipment and Systems (RES); Digital European Cordless Telecommunications (DECT); Common Interface (CI); Part 5: Network (NWK) layer".

- [6] ETS 300 175-6: "Radio Equipment and Systems (RES); Digital European Cordless Telecommunications (DECT); Common Interface (CI); Part 6: Identities and addressing".
- [7] ETS 300 175-7: "Radio Equipment and Systems (RES); Digital European Cordless Telecommunications (DECT); Common Interface (CI); Part 7: Security features".
- [8] ETS 300 175-8: "Radio Equipment and Systems (RES); Digital European Cordless Telecommunications (DECT); Common Interface (CI); Part 8: Speech coding and transmission".
- [9] ETS 300 444: "Radio Equipment and Systems (RES); Digital European Cordless Telecommunications (DECT); Generic Access Profile (GAP)".
- [10] ETS 300 331: "Radio Equipment and Systems (RES); Digital European Cordless Telecommunications (DECT); DECT Authentication Module (DAM)".
- [11] prETS 300 176: "Radio Equipment and Systems (RES); Digital European Cordless Telecommunications (DECT); Approval Test Specification (ATS)".
- [12] 91/263/EEC: "Council Directive of 29 April 1991 on the approximation of the laws of the Member states concerning telecommunications terminal equipment, including the mutual recognition of their conformity". (Terminal Directive).
- [13] ETR 015: "Radio Equipment and Systems; Digital European Cordless Telecommunications (DECT); Reference document".
- [14] ETR 043: "Radio Equipment and Systems (RES); Digital European Cordless Telecommunications (DECT); Common interface; Services and facilities requirements specification".
- [15] ETR 056: "Radio Equipment and Systems (RES); Digital European Cordless Telecommunications (DECT); System description document".
- [16] ETS 300 466: "Radio Equipment and Systems (RES); Digital European Cordless Telecommunications/Global System for Mobile Communications (DECT/GSM) interworking profile; General description of service requirements; Functional capabilities and information flows".
- [17] ETS 300 508: "European digital cellular telecommunications system (Phase 2); International Mobile station Equipment Identities (IMEI) (GSM 02.16)".
- [18] ETR 100: "European digital cellular telecommunications system (Phase 2); Abbreviations and acronyms (GSM 01.04)".
- [19] ETS 300 522: "Digital cellular telecommunications system (Phase 2); Network architecture (GSM 03.02)".
- [20] ETS 300 551: "European digital cellular telecommunications system (Phase 2); GSM Public Land Mobile Network (PLMN) access reference configuration (GSM 04.02)".
- [21] ETS 300 557: "Digital cellular telecommunications system (Phase 2); Mobile radio interface layer 3 specification (GSM 04.08)".
- [22] ETS 300 580-1: "European digital cellular telecommunications system (Phase 2); Full rate speech processing functions (GSM 06.01)".
- [23] ETS 300 590: "Digital cellular telecommunications system (Phase 2); Mobile-services Switching Centre - Base Station System (MSC - BSS) interface; Layer 3 specification (GSM 08.08)".

- [24] ISO/IEC 9646-6: "Information technology - Open Systems Interconnection - Conformance testing methodology and framework - Part 6: Protocol profile test specification".
- [25] ETR 159: "Radio Equipment and Systems (RES); Digital European Cordless Telecommunications (DECT); Wide area mobility using the Global System for Mobile communications (GSM)".
- [26] ETR 206: "Public Switched Telephone Network (PSTN); Multifrequency signalling system to be used for push-button telephones [CEPT Recommendation T/CS 46-02 E (1985)]".
- [27] prETS 300 764: "Radio Equipment and Systems (RES); Digital Enhanced Cordless Telecommunications / Global System for Mobile communications (DECT/GSM) Interworking Profile (IWP); Implementation of short message service, point-to-point and cell broadcast".
- [28] ETS 300 499: "Radio Equipment and Systems (RES); Digital European Cordless Telecommunications/Global System for Mobile Communications (DECT/GSM) interworking profile; Mobile services Switching Centre (MSC) - Fixed Part (FP) interconnection".
- [29] prETS 300 703: "Radio Equipment and Systems (RES); Digital Enhanced Cordless Telecommunications/Global System for Mobile communications (DECT/GSM) Interworking Profile (IWP); GSM phase 2 supplementary services implementation".
- [30] prETS 300 756: "Radio Equipment and Systems (RES); Digital Enhanced Cordless Telecommunications / Global System for Mobile communications (DECT/GSM) interworking profile; Implementation of bearer services".
- [31] TBR 6: "Radio Equipment and Systems (RES); Digital European Cordless Telecommunications (DECT); General terminal attachment requirements".
- [32] TBR 10: "Radio Equipment and Systems (RES); Digital European Cordless Telecommunications (DECT); General terminal attachment requirements: Telephony applications".
- [33] prETS 300 792: "Radio Equipment and Systems (RES); Digital European Cordless Telecommunications / Global System for Mobile Communications (DECT/GSM); DECT/GSM interworking profile; Implementation of facsimile group 3".
- [34] ETS 300 523: "European digital cellular telecommunications system (Phase 2); Numbering, addressing and identification (GSM 03.03)".

### 3 Definitions, abbreviations and symbols

#### 3.1 DECT definitions

For the purposes of this ETS, the following DECT definitions apply:

**attach:** The process whereby a PP within the coverage area of a FP to which it has access rights, notifies this FP that it is operative. The reverse process is detach, which reports the PP as inoperative.

NOTE 1: An operative PP is assumed to be ready to receive calls.

**authentication:** The process whereby a DECT subscriber is positively verified to be a legitimate user of a particular FP.

NOTE 2: Authentication is generally performed at call set-up, but may also be done at any other time (e.g. during a call).

**bearer service:** A type of telecommunication service that provides a defined capability for the transmission of signals between user-network interfaces.

NOTE 3: The DECT user-network interface corresponds to the top of the network layer (layer 3).

**C-Plane:** The control plane of the DECT protocol stacks, which contains all of the internal DECT protocol control, but may also include some external user information.

NOTE 4: The C-Plane stack always contains protocol entities up to and including the network layer.

**call:** All of the Network (NWK) layer processes involved in one network layer peer-to-peer association.

NOTE 5: Call may sometimes be used to refer to processes of all layers, since lower layer processes are implicitly required.

**DECT Network (DNW):** A network that uses the DECT air interface to interconnect a local network to one or more portable applications. The logical boundaries of the DECT network are defined to be at the top of the DECT network layer.

NOTE 6: A DNW is a logical grouping that contains one or more fixed radio termination plus their associated portable radio termination. The boundaries of the DECT network are not physical boundaries.

**Fixed Part (DECT Fixed Part) (FP):** A physical grouping that contains all of the elements in the DECT network between the local network and the DECT air interface.

NOTE 7: A DECT FP contains the logical elements of at least one fixed radio termination, plus additional implementation specific elements.

**Fixed Part GSM PLMN Attachment (DECT Fixed Part attached to a GSM MSC):** A definition of a functional environment where a DECT system (FP) is attached to an GSM MSC. The MSC in this case refers to a functional entity providing the required Mobility Management (MM) and Call Control (CC) functionality defined in this ETS in order to communicate with the FP.

**Fixed radio Termination (FT):** A logical group of functions that contains all of the DECT processes and procedures on the fixed side of the DECT air interface.

NOTE 8: A fixed radio termination only includes elements that are defined in the DECT Common Interface (CI) specification, ETS 300 175, parts 1 to 8 [1] to [8]. This includes radio transmission elements together with a selection of layer 2 and layer 3 elements.

**Generic Access Profile (GAP):** A defined part of the DECT CI specification ETS 300 175, parts 1 to 8 [1] to [8], that ensures inter-operability between FPs and PPs for public business and residential access services.

**geographically unique identity:** This term relates to FP identities, Primary Access Rights Identities (PARIs) and Radio Fixed Part Identities (RFPIs). It indicates that two systems with the same PARI, or respectively two RFPs with the same Radio Fixed Part Identity (RFPI), can not be reached or listened to at the same geographical position.

**Global Network (GNW):** A telecommunication network capable of offering a long distance telecommunication service.

NOTE 9: The term does not include legal or regulatory aspects, nor does it indicate if the network is a public or a private network.

**globally unique identity:** The identity is unique within DECT (without geographical or other restrictions).

**handover:** The process of switching a call in progress from one physical channel to another physical channel. These processes can be internal (see internal handover) or external (see external handover).

NOTE 10: There are two physical forms of handover, intra-cell handover and inter-cell handover. Intra-cell handover is always internal. Inter-cell handover can be internal or external.

**incoming call:** A call received at a PP.

**inter-cell handover:** The switching of a call in progress from one cell to another cell.

**internal handover:** Handover processes that are completely internal to one Fixed radio Termination (FT). Internal handover re-connects the call at the lower layers, while maintaining the call at the NWK layer.

NOTE 11: The lower layer reconnection can either be at the Data Link Control (DLC) layer (connection handover) or at the Medium Access Control (MAC) layer (bearer handover).

**inter-operability:** The capability of FPs and PPs, that enable a PP to obtain access to teleservices in more than one location area and/or from more than one operator (more than one service provider).

**inter-operator roaming:** Roaming between FP coverage areas of different operators (different service providers).

**Interworking Unit (IWU):** A unit that is used to interconnect sub-networks.

NOTE 12: The IWU will contain the interworking functions necessary to support the required sub-network interworking.

**intra-cell handover:** The switching of a call in progress from one physical channel of one cell to another physical channel of the same cell.

**intra-operator roaming:** Roaming between different FP coverage areas of the same operator (same service provider).

**Local Network (LNW):** A telecommunication network capable of offering local telecommunication services.

NOTE 13: The term does not include legal or regulatory aspects, nor does it indicate if the network is a public network or a private network.

**locally unique identity:** The identity is unique within one FP or location area, depending on application.

**location area:** The domain in which a PP may receive (and/or make) calls as a result of a single location registration.

**location registration:** The process whereby the position of a DECT portable termination is determined to the level of one location area, and this position is updated in one or more databases.

NOTE 14: These databases are not included within the DECT FT.

**Medium Access Control (MAC) Connection:** An association between one source MAC Multi-Bearer Control (MBC) entity and one destination MAC MBC entity. This provides a set of related MAC services (a set of logical channels), and it can involve one or more underlying MAC bearers.

**outgoing call:** A call originating from a PP.

**Portable Application (PA):** A logical grouping that contains all the elements that lie beyond the DECT network boundary on the portable side.

NOTE 15: The functions contained in the portable application may be physically distributed, but any such distribution is invisible to the DECT network.

**Portable Part (DECT Portable Part) (PP):** A physical grouping that contains all elements between the user and the DECT air interface. PP is a generic term that may describe one or several physical pieces.

NOTE 16: A DECT PP is logically divided into one portable termination plus one or more portable applications.

**Portable radio Termination (PT):** A logical group of functions that contains all of the DECT processes and procedures on the portable side of the DECT air interface.

NOTE 17: A PT only includes elements that are defined in the DECT CI specification ETS 300 175, parts 1 to 8 [1] to [8]. This includes radio transmission elements (layer 1) together with a selection of layer 2 and layer 3 elements.

**Radio Fixed Part (RFP):** One physical sub-group of an FP that contains all the radio end points (one or more) that are connected to a single system of antennas.

**registration:** An ambiguous term, that should always be qualified. See either location registration or subscription registration.

**roaming:** The movement of a PP from one FP coverage area to another FP coverage area, where the capabilities of the FPs enable the PP to make or receive calls in both areas.

NOTE 18: Roaming requires the relevant FPs and PP to be inter-operable.

**subscription registration:** The infrequent process whereby a subscriber obtains access rights to one or more FPs.

NOTE 19: Subscription registration is usually required before a user can make or receive calls.



### 3.2 Abbreviations

For the purposes of this ETS, the following abbreviations apply:

ARI	Access Rights Identity (see PARI, SARI and TARI)
BCD	Binary Coded Decimal
BSC	GSM Base Station Controller
CC	Call Control
CI	Common Interface
CISS	Call Independent Supplementary Services
CK	Cipher Key
CLMS	Connectionless Message Service
COMS	Connection Oriented Message Service
CRSS	Call Related Supplementary Services
DAM	DECT Authentication Module
SIM/DAM GA	Subscriber Identity Module/DECT Authentication Module, GSM Application
DECT	Digital Enhanced Cordless Telecommunications
DLC	Data Link Control
DSAA	DECT Standard Authentication Algorithm
DTMF	Dual Tone Multi-Frequency
FP	Fixed Part
FT	Fixed radio Termination
GAP	Generic Access Profile
GOP	GSM Operator code
IMEI	International Mobile Equipment Identity
IMSI	International Mobile Subscriber Identity
IPEI	International Portable Equipment Identity
IPUI	International Portable User Identity
ISDN	Integrated Services Digital Network
ISUP	Integrated Services Digital Network User Part
IWU	Interworking Unit
K	authentication Key
LCE	Link Control Entity
LLME	Lower Layer Management Entity
MAC	Medium Access Control
MAP	Mobile Application Part
MM	Mobility Management
MS	Mobile Station
MSB	Most Significant Bit
MSC	Mobile Switching Centre
NWK	Network
O&M	Operations and Maintenance
PA	Portable Application
PARI	Primary Access Rights Identity
PARK	Portable Access Rights Key
PCM	Pulse Coded Modulation
PE	Portable Equipment
PLMN	Public Land Mobile Network
PP	Portable Part
PT	Portable radio Termination
PUT	Portable User Type
RES	A Response calculated by a PP
RFP	Radio Fixed Part
RFPI	Radio Fixed Part Identity
RS	A value used to establish authentication session keys
SARI	Secondary Access Rights Identity
SS	Supplementary Service
SRES	A GSM specific authentication response calculated by the GSM SIM or the DAM GA
TARI	Tertiary Access Rights Identity
TMSI	Temporary Mobile Subscriber Identity
TPUI	Temporary Portable User Identity
TUP	Telephony User Part

### 3.3 GSM abbreviations and definitions

Definition and specific GSM abbreviations may be found in ETR 100 [18] (GSM 01.04).

### 3.4 Symbols for status columns

The symbols defined in this subclause are applied for procedures, features, messages, information elements, fields and field codings in this ETS if not explicitly otherwise stated. The interpretation of status columns in all tables is as follows:

- M for mandatory to map/support/use;
- O for optional to map/support/use;
- I for out-of-scope (not subject for testing);
- X for prohibited or excluded to map/support/use (the message, information element may be allowed to be used in the standard/standards but it is not allowed to be mapped/used depending on the environment/dynamic conditions etc.);
- N/A or -(dash) for not applicable to map/support/use;
- C for conditional to map/support/use (the message, information element mapping depends on the selection of other optional or/and conditional items).

NOTE: The symbol "-" in the mapping subclause of this ETS means that there is no message, information element or coding specified in this column.

## 4 General

This ETS specifies how GSM services are provided over the DECT air interface.

One of the main objectives is to describe how the GSM services are mapped across the DECT air interface in a formal way, so that inter-operability of different manufacturer's equipment can be achieved. This is done by describing the interworking unit procedures and mappings loosely following CCITT Recommendations Q.601 - Q.699 and by describing an air interface profile following ISO 9646-6 [24]. The later document enables the subsequent generation of tests cases, if required.

This ETS is made up of 3 main clauses:

- clause 5: Interworking requirements - includes reference configurations and the protocol architecture models. The main service requirements are described. Interworking requirements are also addressed;
- clause 6: Interworking Unit (IWU) mappings - shows the C-Plane and U-Plane mappings for the FP GSM PLMN attachment. Two IWUs are considered; the FP IWU and the PP IWU, although the FP IWU is expected to be the largest. The signalling mappings are described in terms of IWU procedures with informative data flow diagrams. Detailed descriptions follow using tables of what is mapped, what is ignored, and what is transferred transparently. These clauses also include other profile specific information such as security matters;
- clause 7: Connection types - this clause identifies the main DECT connection types (U-Plane + C-Plane) at the air interface supporting optimized groups of services, from the IWU mappings for different configurations/models.

## 5 Interworking requirements

### 5.1 General

This ETS defines the mandatory requirements for the FP in terms of interworking functions between the air interface and the external network as well as minimum requirements at the DECT air interface. It also defines the mandatory requirements for the PP in terms of interworking functions between the air interface and the Portable Application (PA) as well as the minimum requirements for the PP at the DECT air interface.

The interworking mappings shall be based on the Phase 2 GSM Standards.

The basis for interworking shall be the protocols defined in ETS 300 557 [21] (GSM 04.08) and ETS 300 590 [23] (GSM 08.08).

The procedures which are used depend on which Access Rights Identity (ARI) type is chosen by the PP; either according to the minimum requirements of the GAP or the MM procedures as described in this ETS i.e. the PPs, which are based on this ETS shall always be capable of interworking with FP which fulfil the minimum requirements of the GAP, ETS 300 444 [9]. The FPs, which fulfil the requirements of this ETS, and which also support non-GSM ARIs (classes A, B or C) shall also support the minimum requirements of the GAP.

This ETS defines interworking environments for the FP and the PP in the case when DECT FPs are functionally attached to the GSM MSC i.e. broadcast attribute a39 "SIM services available" set to "1"B in all environments (public, business and residential).

All messages, information elements or fields within the information elements which are not mapped across the FP to the GSM network shall either be ignored or processed locally.

### 5.2 Reference configurations

Reference configurations describe the functional groupings of DECT and GSM and their relationships via reference points. In general, reference points may or may not correspond to a physical interface. The functional groupings and reference points for GSM access are described in ETS 300 551 [20] (GSM 04.02). The GSM network entities and physical interfaces are described in ETS 300 522 [19] (GSM 03.02). The functional (logical) groupings and reference points for DECT are described below.

#### 5.2.1 FP functional attachment to the GSM PLMN

Reference point "a" in figure 1 is the interface which supports the functional structure of the GSM A-interface at the network layer reflecting the associated Integrated Services Digital Network (ISDN) User Part (ISUP)/Telephony User Part (TUP) and GSM Mobile Application Part (MAP) functions.

In this ETS, GSM or DECT procedures are considered only where mapping is required, i.e.:

- GSM MM and CC are completely covered in this ETS as far as basic speech is concerned;
- mapping aspects for ciphering, paging and handover are also covered in this ETS. Further details of these procedures are described in ETS 300 499 [28]. ETS 300 499 [28] also provides descriptions for handling of other A-interface functionality (of ETS 300 590 [23] (GSM 08.08)) which are out of scope of this ETS, but which may occur during the procedures described in this ETS (e.g. channel assignment).

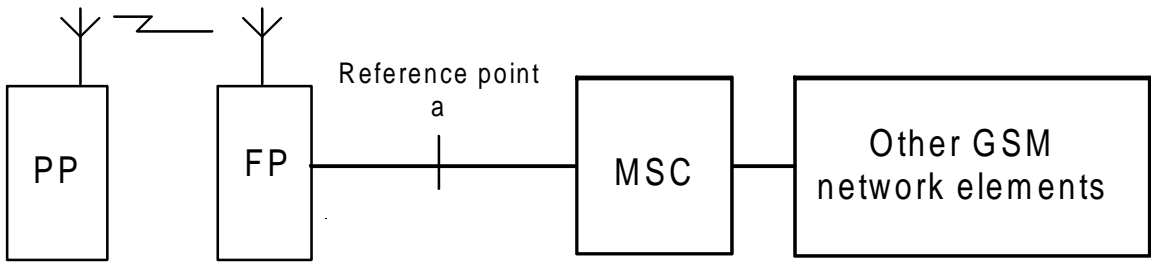

Figure 1: Attachment to the GSM PLMN

5.3 General interworking model for FP GSM PLMN attachment

Interworking models shown below are used to describe the protocol interactions at control plane (C-Plane) and of the FP and PP. The protocol architecture model also shows the location of the IWUs.

The IWU (figure 2) in the FP provides the mapping between a subset of GSM layer 3 to the corresponding DECT NWK protocols. The IWU in PP provides mapping between a subset of the DECT NWK protocol and the GSM application (Subscriber Identity Module / DECT Authentication Module, GSM Application (SIM/DAM GA)).

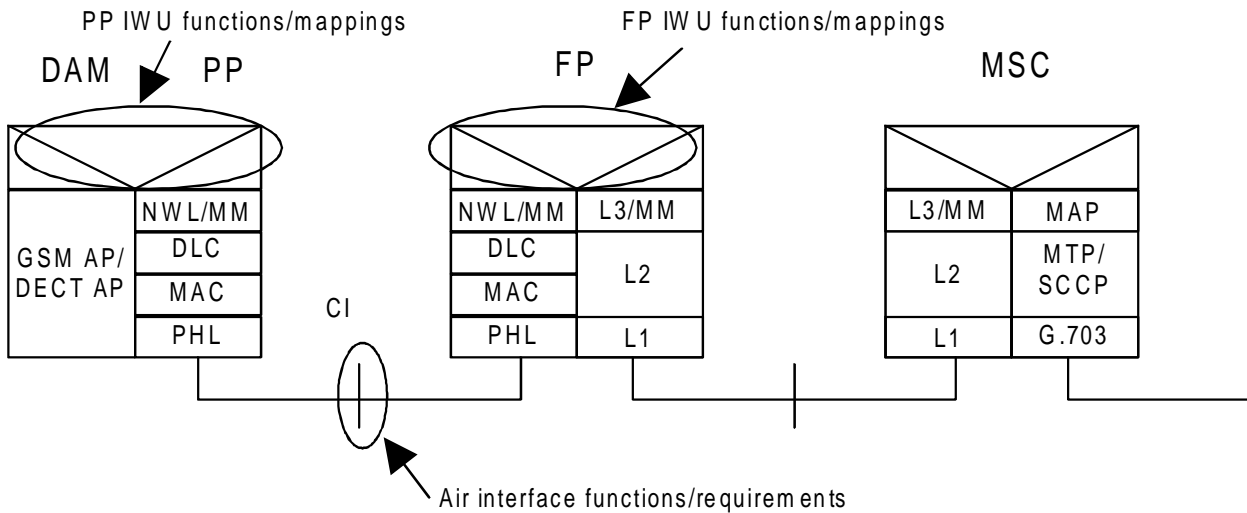

Figure 2: Interworking model for MM for FP GSM PLMN attachment

5.4 Interworking context

5.4.1 General

The PP shall be backwards compatible with the minimum requirements of GAP. This means that all mandatory parts of GAP remain mandatory. The FP is based on GAP, but not all the mandatory provisions are required in all environments.

The FPs can be divided in two categories:

- a) the FPs which support ARI class D only. These FPs are "transparent" in terms of procedures and are normally initiated either by the PP or the GSM PLMN. These FPs shall support the procedures as defined in the relative subclause of clause 6 of this ETS;
- b) the FPs which support ARI class D but also support ARI classes A, B or C shall support, in addition to the procedures defined in clause 6 of this ETS, the mandatory procedures as defined in ETS 300 444 [9].

#### 5.4.2 Basic interworking rules

In the context of this ETS, the broadcast attribute a39 (SIM services available) shall uniquely determine if the FP is attached to the GSM PLMN. The interpretation of the broadcast attribute a39, when set to value "1", is as follows:

- a) a PP shall always use International Portable User Identity (IPUI) type R if it wants to access a GSM PLMN;
- b) an FP belonging to ARI class D shall support the DECT/GSM interworking profile. The GSM Operator code (GOP) value is described in ETS 300 175-6 [6].

NOTE 1: An FP belonging to ARI class A, B, or C in addition to ARI class D shall support the minimum requirements of the GAP.

- c) the profile as defined in this ETS may be used in association only with FPs belonging ARI class D;
- d) a PP accessing an FP of ARI class D may attempt to access the FP/GSM PLMN regardless of the GOP value, as defined in ETS 300 175-6 [6], subclause 5.4. If, however, the ARI class D is stored in the forbidden PLMNs list in the SIM/DAM GA, the PP shall not attempt to access the system except using manual intervention by the user, as defined in subclause 6.3.2.3;

NOTE 2: A standard GSM subscriber (using Mobile Station (MS)) is allowed to roam between different GSM PLMNs. No restrictions, but only a possible list of forbidden PLMNs in terms of accessing a visited PLMN, is applied.

- e) a PP accessing a FP belonging to ARI class A, B or C shall have a correct Portable Access Rights Key (PARK) authentication Key (K) value;
- f) IPUI R shall have the same value as the International Mobile Subscriber Identity (IMSI) in the SIM/DAM GA;
- g) the FP shall broadcast the ARI class D as a Primary ARI (PARI). Additional ARI's of class A, B or C may be broadcast as part of the Secondary ARI (SARI) list;
- h) if broadcast attribute a44 (access rights request supported) is set to value "1" the PP may perform the access rights request procedure to FPs belonging to ARI classes A, B or C using the existing IPUI type R value. If a44 is set to value "0", the access rights procedures shall not be initiated by the PP;
- j) in association with ARI class D the PP shall not initiate the following procedures: authentication of FP (using DSAA or GSM algorithm), obtaining access rights or access rights terminate procedures;
- k) in association with ARI class D the FP shall not initiate the following procedures: authentication of PP (using DECT Standard Authentication Algorithm (DSAA)), authentication of user (using DSAA), key allocation, FT terminating access rights, incrementing the ZAP value.
- l) all network layer entities no longer requiring the link shall issue an "NLR" (no link required) notification to the Link Control Entity (LCE) with a release reason "partial release". This applies to both PP and FP.

Table 1 shows the interworking requirements for the PP relating to different ARI classes. It is assumed that the system broadcasts "SIM services available", a39, as "1"B.

**Table 1: Interworking matrix for the PP**

Requirements\ARI class	ARI class D	ARI class A, B or C
Access to system	Direct, no PARK required	PARK required
Subscription	IPUI type R (IMSI) only	Relevant IPUI in association with PARK

Table 2 defines the associated GSM and DECT procedures required in the FP and the PP.

**Table 2: Implementation/support requirements of DECT and GSM procedures in the FP and the PP**

GSM procedure	DECT procedure	PP	FP
Authentication procedure	Authentication of PT	M	M
Identity procedure	Identification of PT	M	M
Attach procedure	Attach (= Location registration)	M	M
Detach procedure	Detach	M	M
Location updating procedure	Location registration	M	M
TMSI re-allocation procedure	Temporary identity assignment	M	M
Ciphering procedure	Cipher-switching initiated by FT Cipher-switching initiated by PT	M note 1	M note 1
MSC associated handover	External handover	O note 4	O note 4
CM service procedure	Outgoing call request	M	M
MM status procedure	-	-	I
-	Parameter retrieval (Location update)	M	M
Outgoing call initiation note 2	Outgoing call request and overlap sending procedure	M	M
Incoming call setup	Incoming call request	M	M
Emergency call establishment procedure	Emergency call establishment procedure	M	M
Accepted call establishment note 3	Accepted call establishment	M	M
Abnormal call clearing	Abnormal call release (call reject)	M	M
Normal call clearing	Normal call release	M	M
Paging	Paging	M	M
C1: IF ARI class D THEN X ELSE O C2: IF ARI class D THEN X ELSE I			
NOTE 1: Cipher switching initiated by the PT may depend on the implementation of external handover procedure.			
NOTE 2: Outgoing call initiation includes the following ETS 300 557 [21] (GSM 04.08) layer 3 procedures: 1) CM- service procedure; 2) receipt of Setup message.			
NOTE 3: Accepted call establishment consists of call proceeding confirmation, connection phases.			
NOTE 4: The implementation of this feature is optional in the PT and FT. Interworking requirements/mappings are process mandatory.			
TMSI: Temporary Mobile Subscriber Identity			

### 5.4.3 Location area mapping

The following rules are applied for the functional FP to MSC attachment:

- a) RFPs belonging to the same DECT location area shall always be associated to the same GSM location area;
- b) the association of RFPs to GSM location areas (i.e. how the MSC addresses the RFPs/FPs associated to a certain GSM location area) is a implementation specific matter in the MSC and the FP.

In addition to the GSM location areas, the FP may support "internal" DECT areas. The PP (as GAP is the base) shall support GSM location areas, as well as location registration for DECT "internal" areas.

An FP can have several DECT location areas as far as their domains are never split between two GSM location areas.

NOTE: If all RFPs belong to the same GSM location area, the FP may have only one location area (LAL=default) or several.

If part of the RFPs are in different GSM location areas, the FP domain shall be divided into location areas according to the borders of the GSM location areas. The FP may have as many or more than the number of GSM areas.

Upon change of DECT location area without changing the GSM location area, the location registration procedure should be terminated in the FT and the FT-IWU shall not start any GSM related location procedure.

TPUIs may be assigned.

#### 5.4.4 Interpretation of broadcast attributes

This subclause refers to annex F of ETS 300 175-5 [5] (Broadcast attributes coding) and subclauses 7.2.3.4 and 7.2.3.5 or ETS 300 175-3 [3]. It is assumed that the DECT system is attached to a GSM PLMN. Values of broadcast attributes not described below in this subclause are outside the scope of this ETS.

Standard capabilities: physical and MAC layer capabilities:

**a12 Extended FP Info (QH=4):** shall always be set to value "1".

Standard capabilities: higher layer capabilities:

**a32 ADPCM/G.721 Voice service:** shall always be set to value "1";

**a37 Standard ciphering supported:** shall always be set to value "1";

**a38 Location registration supported:** shall always be set to value "1";

**a39 SIM services available:** this broadcast attribute is always set to the value "1" for FPs attached to GSM (PLMN);

**a44 Access Rights requests supported:** indicates that the PP may perform the access rights procedure to systems associated to the non ARI class D systems. The PP shall not attempt to perform the Access Rights procedure associated to a system broadcasting ARI class D only;

**a45 External handover supported:** indicates that the FP supports the external hand over procedure;

**a46 Connection handover supported:** the "0" setting is not used. If it is set to value "1" at least connection handover is being supported.

Extended fixed part capabilities:

**a40 Support of Emergency call:** shall always be set to value "1".

## 6 Interworking mappings, FP attached to the GSM PLMN

### 6.1 FP C-Plane IWU procedures

This clause focuses on the basic interworking profile procedures (see table 2); the main subclauses focus on the procedures mentioned below:

- call establishment and call release procedures;
- registration, security related, connection management procedures;
- paging related interworking procedures;
- other specific IWU procedures;
- exception handling.

For some procedures, performing the exact message-to-message mapping is not possible. For example, a strict relationship between earlier call establishment (outgoing call initiation procedure) and connection management procedures exists. In fact, if a GSM Network attachment is needed, a GSM MM connection establishment for service provision is required before the network call setup. In the DECT context, mobile access to the network is allowed before Service Request, Authentication, Ciphering procedures invocation. Besides, the GSM message contains the dialling info. This is not always the case in DECT: the network may receive the dialling from the PT in a {CC-INFO} message after a {CC-SETUP} message receipt. All this renders subclauses 6.1.2.7 and subclause 6.1.1.1 procedures mappings and, further on, subclause 6.1.6.2.6 ({CC-SETUP} to CM-Service Request) and subclause 6.1.6.2.10 ({CC-INFO} to message mappings).

#### 6.1.1 Call handling IWU procedures

##### 6.1.1.1 Normal outgoing call

The PT and FT shall support dialling information included in the <<MULTI-KEYPAD>>information element in one or several {CC-INFO} messages., as described in clause 8 of ETS 300 444 [9], see a) below.

The PT may optionally support and the FT shall support dialling information included in the <<CALLED-PARTY-NUMBER>> information element of the {CC-SETUP} message, see b) below. Upon receipt of a MNCC\_SETUP-ind primitive from the FT as a result of a received {CC-SETUP} message from the PT one of the following events shall occur in the FP IWU: (a or b)

- a) No <<CALLED-PARTY-NUMBER>> included in the {CC-SETUP}. Dialling in {CC-INFO} in DECT OVERLAP SENDING state:
- in the case of the {CC-SETUP} does not contain <<CALLED-PARTY-NUMBER>>, then the FP/IWU shall, upon receipt of a CM-service accept message from MSC or successful start of ciphering, issue a MNCC\_SETUP\_ACK-req primitive, and this shall result in a {CC-SETUP-ACK} message being sent back to the PT. The {CC-SETUP-ACK} message shall include the <<DELIMITER-REQUEST>> information element;
  - in the error condition case, when the {CC-SETUP} does not contain <<CALLED-PARTY-NUMBER>>, but does contain <<SENDING-COMPLETE>>, then the FP IWU shall reject the {CC-SETUP} by responding with MNCC\_REJECT-req primitive and this shall result in a {CC-RELEASE-COM} message being sent back to the PT;
  - prior to sending the Setup message to the MSC the FP IWU shall initiate the CM service procedure as described in subclause 6.1.2.7. The CM-service procedure shall be initiated upon receipt of the {CC-SETUP} message, i.e. prior to when the FP has received dialling information;



- the <<MULTI-KEYPAD>> information element shall be used for dialling information. The IWU shall either:
  - 1) not send a Setup message to the MSC before it receives a <<SENDING-COMplete>> information element; or
  - 2) alternatively a timer can be implemented in the FP IWU;

upon receipt of the <<SENDING-COMplete>> information element, or expiry of this timer, the FP IWU shall send Setup to the MSC with all the stored digits received in previous {CC-INFO} messages mapped into the GSM <<CALLED-PARTY-BCD-NUMBER>> information element. The mapping from {CC-INFO} to Setup shall be carried out as described in subclause 6.1.6.2.10;
- if the MSC replies with Call proceeding, Alerting and/or Connect messages as a response to the received Setup message, the mapping to corresponding DECT messages shall be done as described in subclauses 6.1.6.1.9, 6.1.6.1.8, and 6.1.6.1.10. Upon receipt of a Connect from the MSC, in addition to the mapping function to the FP, the FP IWU shall send a Connect-ack message to the MSC. MNCC\_CALL\_PROC-req, MNCC\_ALERT-req and MNCC\_CONNECT-req shall never be issued to the FT before their peer GSM messages have been received by the FP IWU;
- if the MSC replies with a Release message as a response to the Setup message sent to the MSC, the FP IWU shall apply the appropriate release procedure defined in subclause 6.1.1.7;
- if the MSC does not reply with a Call proceeding, Alerting or Connect message and the timer F<CC.01> expires, the FP shall release the call by issuing a MNCC\_RELEASE-ind primitive. The FP IWU shall upon receipt of the MNCC\_RELEASE-ind primitive send a Release message to the MSC;
- if the MSC does not send a Connect message after it has sent Call proceeding and/or Alerting and the timer F<CC.04> expires, the FP shall release the call by issuing a MNCC\_RELEASE-ind primitive. The FP IWU shall upon receipt of the MNCC\_RELEASE-ind primitive send a Disconnect message to the MSC.

NOTE 1: When the FT is in state F-03 or F-04 the FP IWU may map all received {CC-INFO} messages to GSM, but how it is done is outside the scope of this ETS (normally related to supplementary services).

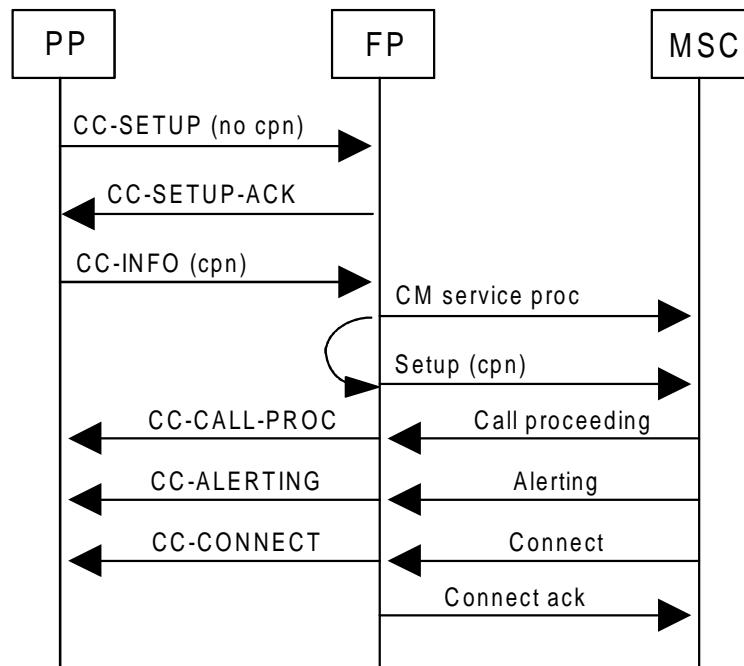

Figure 3: FP receives the dialling information (cpn) in {CC-INFO} message

The outgoing call procedure with a <<MULTI-KEYPAD>> information element included in the {CC-INFO} messages for called party addressing is shown in figure 4.

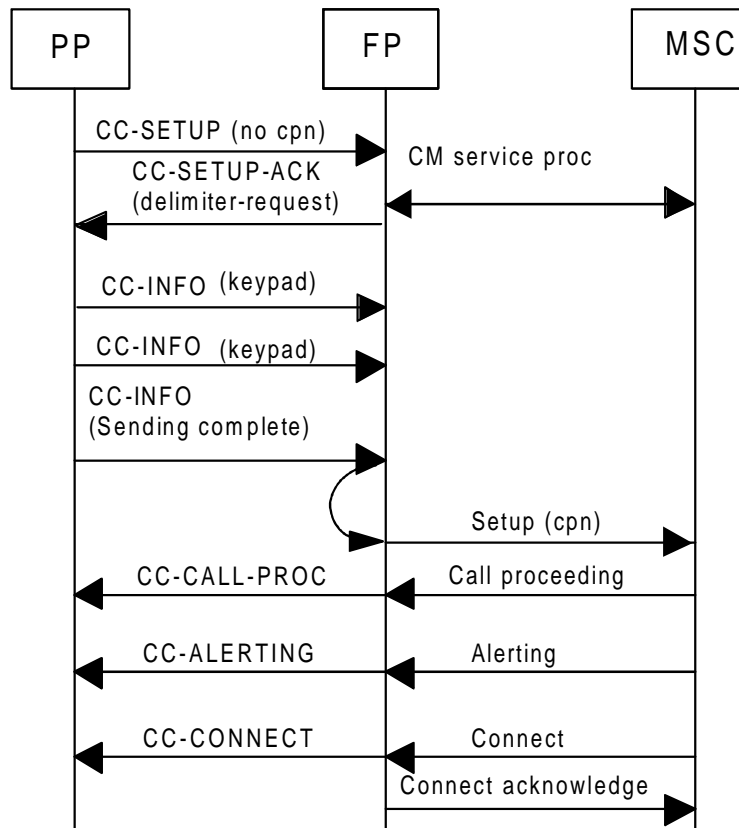

Figure 4: FP receives the dialling information (Multi keypad) in {CC-INFO} message

b) <<CALLED-PARTY-NUMBER>> included in the {CC-SETUP}:

- in the case of the {CC-SETUP} contains <<CALLED-PARTY-NUMBER>> with or without the <<SENDING-COMPLETE>> information element, the FP IWU shall interpret the dialling as finished and therefore map the DECT {CC-SETUP} to the GSM Setup as described in subclause 6.1.6.2.15. Prior to this the IWU shall initiate the CM service procedure as described in subclause 6.1.2.7;
- if the MSC replies with Call proceeding, Alerting and/or Connect messages as responses to the Setup message, the mapping to corresponding DECT messages shall be done as described in subclauses 6.1.6.1.9, 6.1.6.1.8, and 6.1.6.1.10. Upon receipt of a Connect from the MSC, in addition to the mapping function to the FP, the FP IWU shall send a Connect-ack message to the MSC. MNCC\_CALL\_PROC-req, MNCC\_ALERT-req and MNCC\_CONNECT-req shall never be issued to the FT before their peer GSM messages have been received by the FP IWU;
- if the MSC replies with a Release or a Release complete message as a response to the sent Setup message to the MSC, the FP IWU shall apply the appropriate release procedure defined in subclause 6.1.1.7;
- if the MSC does not send a Connect message after it has sent Call proceeding and/or Alerting and the timer F<CC.04> expires, the FP shall release the call by issuing a MNCC\_RELEASE-ind primitive. The FP IWU shall upon receipt of the MNCC\_RELEASE-ind primitive send a Disconnect message to the MSC.

NOTE 2: When the FT is in state F-03 or F-04 the FP IWU may map all received {CC-INFO} messages to GSM, but how it is done is outside the scope of this ETS (normally related to supplementary services).

The outgoing call procedure with a <<CALLED-PARTY-NUMBER>> information element included in the {CC-SETUP} message is shown in figure 5.

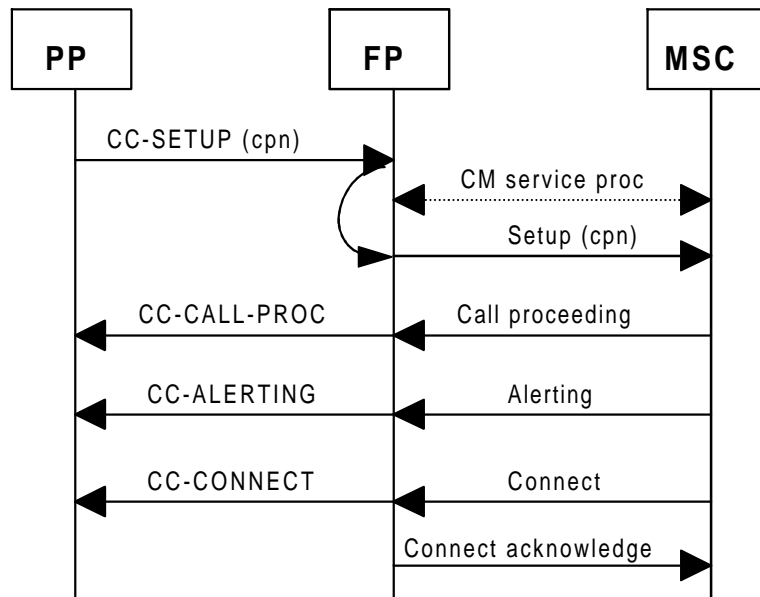

Figure 5: FP receives the dialling information (cpn) in {CC-SETUP} message

The CM service procedure (as defined in subclause 6.1.2.7) shall occur prior to the Setup message being sent to the MSC. Other GSM network initiated procedures may also occur prior to sending the Setup message.

NOTE 3: The number of received dialled digits by the FP IWU may exceed the number of supported digits in the GSM <<called party BCD number information element>> of the Setup message. Appropriate handling is manufacturer dependant.

### 6.1.1.2 Emergency call

The "Emergency call set-up" value in the <<BASIC-SERVICE>> information element shall be used to initiate, the GSM "Teleservice Emergency call".

If the <<BASIC-SERVICE>> information element in a received {CC-SETUP} message is set to value "Emergency call set-up", then the {CC-SETUP} message shall be mapped to a Emergency setup message as described in subclause 6.1.6.2.16. Prior to sending a Emergency Setup message towards the GSM MSC, the FP IWU shall initiate the CM-service procedure as described in subclause 6.1.2.7. The value of the <<CM service type>> information element shall in this case be set to value "Emergency call establishment". The value of the <<PORTABLE IDENTITY>> information element shall be set to IPUI type N (International Portable Equipment Identity (IPEI)), see subclause 6.3.1.1.2.

All further actions in the FP IWU shall be as for a normal outgoing call.

### 6.1.1.3 Incoming call

Upon receipt of a Setup message from the MSC as a result of the GSM mobile terminating call establishment procedure, the FP IWU shall issue a MNCC\_SETUP-req primitive to the FT. The GSM Setup message shall be mapped into DECT {CC-SETUP} message as described in subclause 6.1.6.1.11.

NOTE 1: Prior to the GSM Setup being received at the IWU, MM-connection establishment has been achieved from the MSC to the PP using the paging procedure as described in subclause 6.1.3.

If the FP/IWU receives a Setup message from the MSC with a <<Bearer capability>> information element it does not support, the FP/IWU shall respond with a Release Complete message with <<Cause value>> information element #88 "incompatible destination".

PT alerting may be initiated in two ways:

- 1) by including a <<SIGNAL>> information element in the {CC-SETUP} message; or
- 2) by sending a {CC-INFO} message with a <<SIGNAL>> information element included.

In case the first method is used, FP IWU shall issue MNCC\_SETUP-req primitive including a <<SIGNAL>> information element to the FT.

In case the second method is used, after {CC-SETUP} message sent to PT, FP IWU shall issue a MNCC\_INFO-req primitive with a <<SIGNAL>> information element included upon completion of assignment procedure.

FP IWU is required to support one of the methods, PP is required support both.

In the case that the destination PP is determined to be busy, the FP IWU shall return either a Call confirmed or Release complete to the MSC, both with cause #17 "user busy". After sending Release complete the FP IWU shall consider the MM-connection with the MSC as released.

The IWU shall wait to receive MNCC\_ALERT-ind or MNCC\_CONNECT-ind from the FT. If the FP/IWU receives a {CC-RELEASE-COM} message with <<RELEASE-REASON>> H05 "incompatible service", the FP/IWU shall send a Release complete message to the MSC containing the mapped <<Cause value>> conforming to subclause 6.1.8.2.20.

If the IWU receives MNCC-ALERT-ind prior to MNCC\_CONNECT-ind (figure 6), the IWU shall issue a Call confirmed message indicating the relevant <<BEARER CAPABILITY>> information elements to the MSC. If no <<BEARER CAPABILITY>> has been received, the FP IWU shall assume speech. Then the FP IWU shall map the {CC-ALERTING} and possible subsequent {CC-CONNECT} into the corresponding GSM messages according to subclauses 6.1.6.2.8 and 6.1.6.2.9 respectively. Upon receipt of a {CC-CONNECT-ACK} message from the MSC, this message shall be mapped into the DECT {CC-CONNECT-ACK} message as described in subclause 6.1.6.1.17.

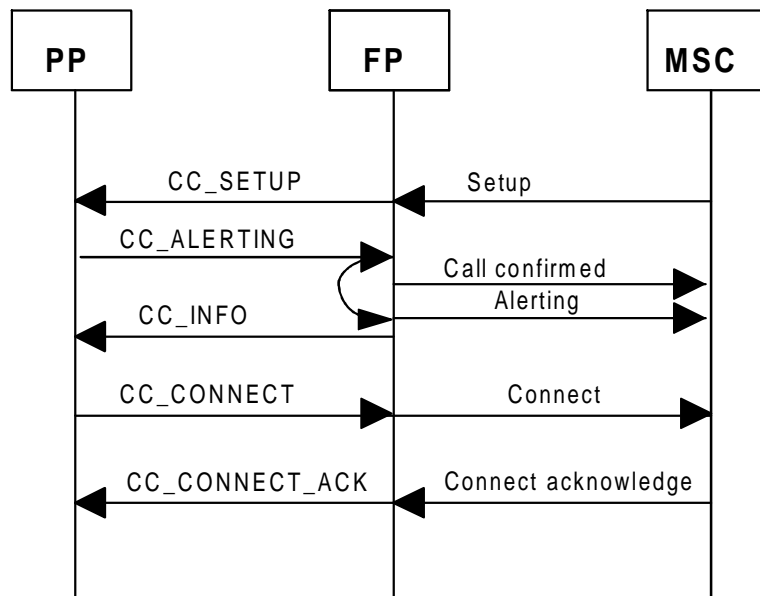

**Figure 6: Incoming call where the IWU receives MNCC\_ALERT-ind prior to MNCC\_CONNECT-ind**

If the IWU receives MNCC\_CONNECT-ind without MNCC\_ALERT-ind (possible only if ARI class D otherwise prohibited.) see figure 7, the FP IWU shall issue a Call confirmed message indicating the relevant <<BEARER CAPABILITY>> information elements towards the MSC. If no <<BEARER CAPABILITY>> have been received, the FP IWU shall assume speech. After this the FP IWU shall map the {CC-CONNECT} into the corresponding GSM message according to subclause 6.1.6.2.9. When the {CC-CONNECT} message is received from the PT the FT sends {CC-CONNECT-ACK} message to the PT.

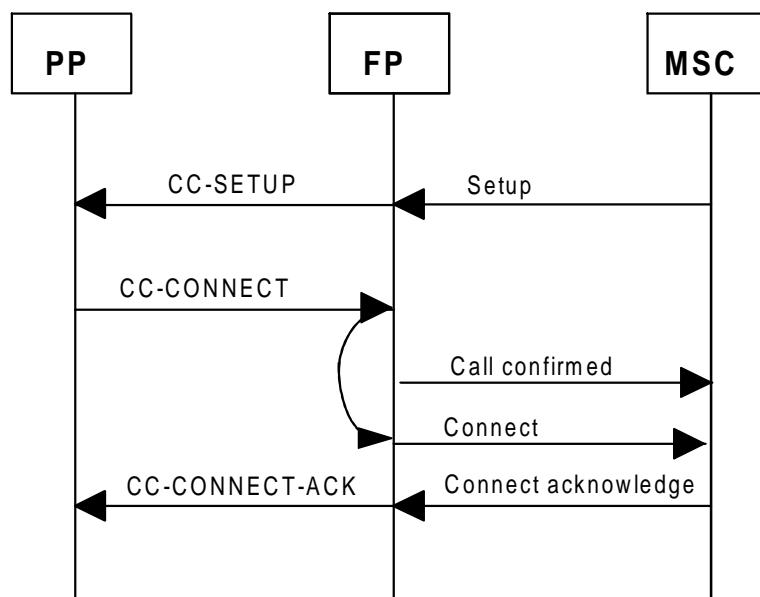

**Figure 7: Incoming call where the IWU receives MNCC\_CONNECT-ind without MNCC\_ALERT-ind**

If F <CC.03> expires, while waiting for {CC-ALERTING} or {CC-CONNECT} from the PT, the FP shall issue a MNCC\_REJECT-ind primitive to the FP IWU. The FP IWU shall send a RELEASE COMPLETE message to the MSC.

If F <CC.04> (optional) expires, while waiting for {CC-CONNECT}, the FP shall issue a MNCC\_RELEASE-ind primitive to the FP IWU. The FP IWU shall send a Disconnect message to the MSC.

#### 6.1.1.4 Normal call release initiated by the PP

Upon receipt of a MNCC\_RELEASE-ind primitive as a result of a received {CC-RELEASE} message from the PT the FP IWU shall send a Disconnect message to the MSC. The mapping of the DECT {CC-RELEASE} message to the GSM Disconnect message is described in subclause 6.1.6.2.11.

Upon receipt of a Release message from the MSC, the IWU shall issue a MNCC\_RELEASE-res primitive to the FT. The mapping of the GSM Release message to DECT {CC-RELEASE-COM} message is described in subclause 6.1.6.1.13. The FP shall also send a Release complete message to the MSC.

The normal call release initiated by the PP is shown in figure 8.

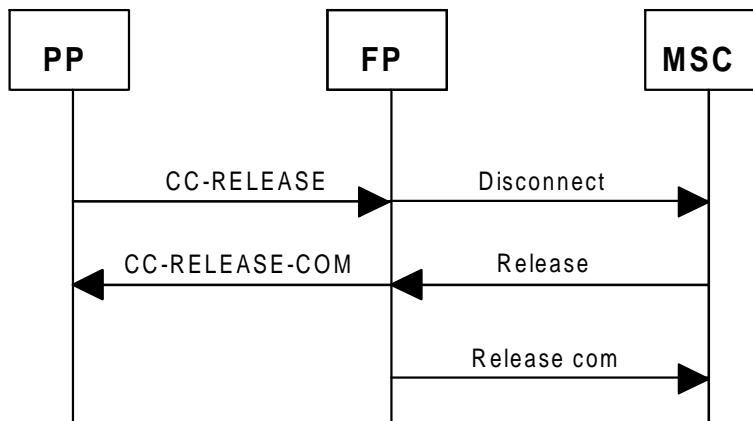

Figure 8: Normal release initiated by the PP

If P <CC.02> expires due to the fact that no RELEASE message has been received from the MSC and therefore no {CC-RELEASE-COM} message has been sent to the PT, the PT sends a {CC-RELEASE-COM} to the FP. The FP shall issue a MNCC\_RELEASE-cfm primitive to the FP IWU which will send a RELEASE message to the MSC.

#### 6.1.1.5 Normal call release initiated by the GSM PLMN

The normal call release initiated by the GSM network shall be carried out by using the Disconnect message.

Two cases can be discerned depending on the presence of inband information.

If the <<Progress indicator>> information element in the Disconnect message indicates "Inband information or appropriate pattern now available", or the FP requires a traffic channel on the air interface, e.g. for transporting inband tones, the following procedure shall take place:

Upon receipt of a Disconnect message from the MSC the FP IWU may issue inband tones towards the PP and issue a MNCC\_INFO-req primitive with a <<Progress>> information element for activating the U-Plane between FP and PP. The mapping of the GSM Disconnect to the DECT {CC-INFO} message is described in subclause 6.1.6.1.20.

If the PP user does not release the call, the FP IWU shall issue a MNCC\_RELEASE-req on receipt of the Release message. This shall result in the {CC-RELEASE} message being sent to the PT. The mapping of the GSM Release message to the DECT {CC-RELEASE} message is described in subclause 6.1.6.1.21.

If the FP IWU receives a MNCC\_RELEASE-cfm from the FT, the DECT {CC-RELEASE-COM} message (figure 9) is mapped into the GSM Release complete message as described in subclause 6.1.6.2.14.

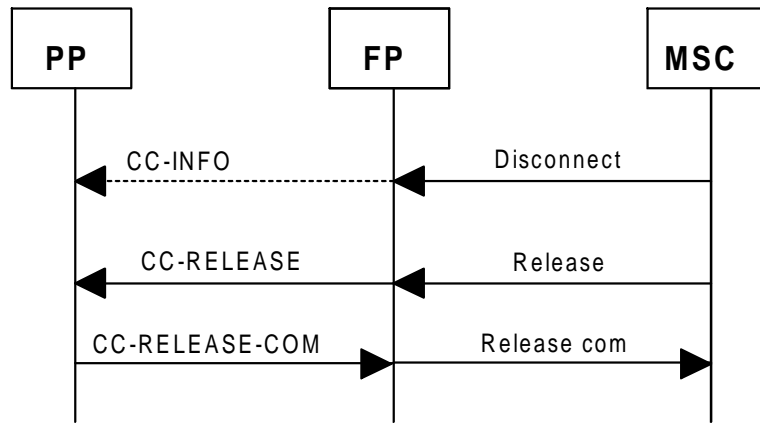
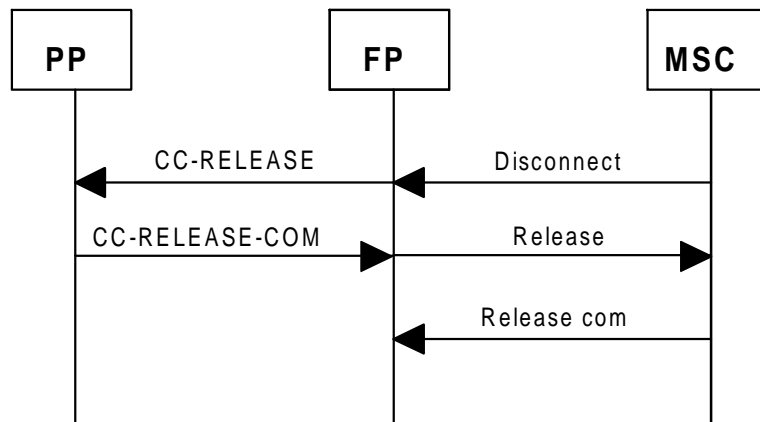

**Figure 9: Normal MSC initiated call release with tones**

If the <<Progress indicator>> information element is not present in the Disconnect message or if the value of the <<Progress indicator>> information element in the Disconnect message does not indicate "Inband information or appropriate pattern now available", and the FP does not require a traffic channel on the air interface, e.g. for transporting inband tones, the following clearing procedure shall take place:

Upon receipt of a Disconnect message from the MSC the FP IWU shall issue a MNCC\_RELEASE-req and this shall result in the {CC-RELEASE} message being sent to the PT. The mapping of the GSM Disconnect message to the DECT {CC-RELEASE} message is described in subclause 6.1.6.1.12.

If the FP IWU receives a MNCC\_RELEASE-cfm from the FT, the DECT {CC-RELEASE-COM} message (figure 10) is mapped into the GSM Release as described in subclause 6.1.6.2.12. The reception of a Release complete message from the MSC shall terminate at the FP IWU.



**Figure 10: Normal MSC initiated call release with no tones**

If F <CC.02> expires, the FP issues a MNCC\_RELEASE-cfm primitive to the FP IWU. The FP IWU shall send a RELEASE message to the MSC.

The FP IWU at sending of RELEASE message to the MSC shall start a timer supervizing the reception of a RELEASE COMPLETE message (this timer is similar to timer T308 in ETS 300 557 [21] (GSM 04.08)). At the first expiry of this timer, the FP IWU shall retransmit the RELEASE message to the MSC and restart the timer. At the second expiry, the call shall be terminated at the FP IWU.

### 6.1.1.6 Abnormal call release initiated by the PP

Abnormal release is indicated by the unexpected receipt (without a prior transmission of a {CC-RELEASE} message) of a {CC-RELEASE-COM} message.

Case A) {CC-RELEASE-COM} received by the FT:

- upon receipt of a MNCC\_REJECT-ind primitive from the FT as a {CC-RELEASE-COM} message received from the PT the FP IWU shall send a Release message to the MSC. The mapping of the DECT {CC-RELEASE-COM} message to the GSM Release message is described in subclause 6.1.6.2.12. The reception of a Release complete message from the MSC shall terminate at the FP IWU.

The abnormal call release initiated by the PT in this case is shown in figure 11.

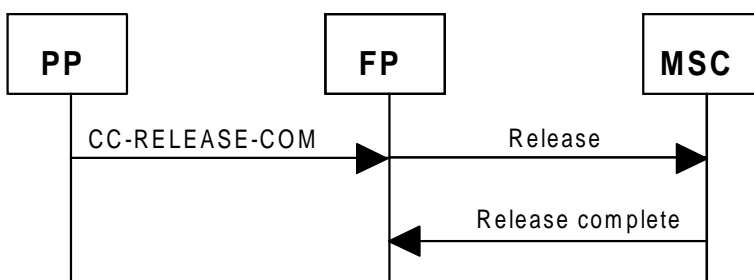

Figure 11: Abnormal call release initiated by the PT

The FP IWU at sending of RELEASE message to the MSC shall start a timer supervizing the reception of a RELEASE COMPLETE message (this timer is similar to timer T308 in ETS 300 557 [21] (GSM 04.08). At the first expiry of this timer, the FP IWU shall retransmit the RELEASE message to the MSC and restart the timer. At the second expiry, the call shall be terminated at the FP IWU.

Case B) if the {CC-RELEASE-COM} is the response to a {CC-SETUP} message triggered by a Setup message from the MSC:

- upon receipt of a MNCC\_REJECT-ind primitive from the FT as a {CC-RELEASE-COM} message received from the PT the IWU shall send a Release complete message to the MSC. The mapping of the DECT {CC-RELEASE-COM} message to the GSM Release complete message is described in subclause 6.1.6.2.14.

The abnormal call release initiated by the PT in this case is shown in figure 12.

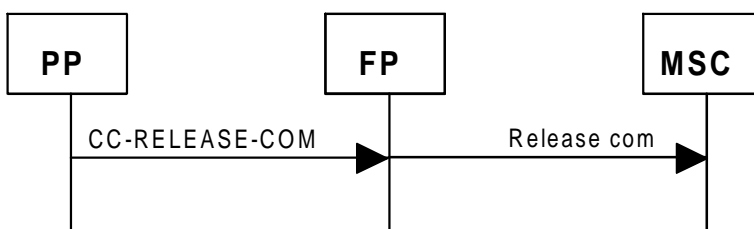

Figure 12: Abnormal call release initiated by the PT



### 6.1.1.7 Abnormal call release initiated by the GSM network

Abnormal call release in the sense of this subclause means that the GSM network sends a Release or a Release complete message but not as a part of the procedure described in subclause 6.1.1.6.

Upon receipt of a Release message from the MSC the IWU shall send Release complete back to the MSC and map the GSM Release into the DECT {CC-RELEASE-COM} message as described in subclause 6.1.6.1.13.

The abnormal call release using Release initiated by the MSC is shown in figure 13.

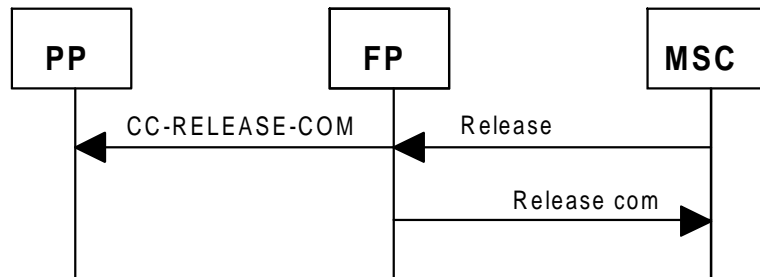

Figure 13: MSC initiates a call release with the Release message

The MSC may send directly RELEASE COMPLETE message in this case the FP IWU shall send a MNCC\_REJECT-req reflecting in a {CC-RELEASE-COM} being sent to the PT.

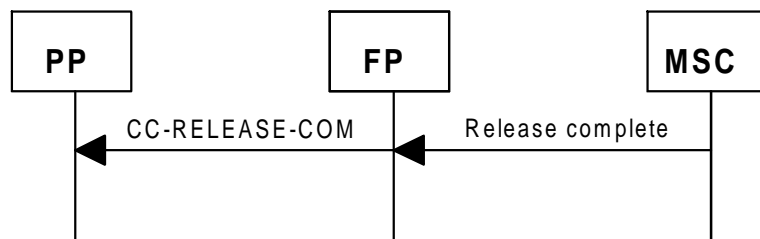

Figure 14: MSC initiates a call release with the Release complete message

### 6.1.1.8 Exceptional cases

The MSC may send an Abort message at any time see ETS 300 557 [21] (GSM 04.08), subclause 4.3.5. If the FP IWU receives Abort message after it has sent the Setup to the MSC or after it has sent a MNCC\_SETUP-req primitive to the FT (to be reflected as a {CC-SETUP} message to the PP), the FP IWU shall send a MNCC\_REJECT-req reflecting in a {CC-RELEASE-COM} being sent to the PT carrying an appropriate release reason.

In overload situations, the FP IWU may decide to reject an incoming MNCC\_SETUP-req primitive by sending a MNCC\_REJECT-req primitive reflecting in a {CC-RELEASE-COM} message being sent to the PT. The included <<RELEASE REASON>> information element shall contain one of the temporary overload values indicated in ETS 300 175-5 [5]. The PP will, by one of these cause values, be informed about a temporary failure.

If a release collision occurs the FP IWU shall react towards MSC as it is specified in ETS 300 557 [21] (GSM 04.08) and no mapping is required i.e. no messages are required to be sent back to the PT.

Timer expiry at the FP-IWU shall be handled with respect to the on going procedure and existing state according to ETS 300 557 [21] (GSM 04.08) and ETS 300 175-5 [5] respectively.

### 6.1.1.9 Other

The DLC "more bit" shall be used when doing segmentation as defined in DECT ETS 300 175-4 [4].

### 6.1.2 Other IWU procedures

This subclause contains security and mobility related procedures and the GSM specific CM service procedure.

NOTE: The GSM specific CM service procedure is initiated during the DECT call establishment phase (upon receipt of the DECT {CC-SETUP} message). With this exception, all interworking functions in the FP are related to MM procedures on both sides (DECT and GSM).

All messages, information elements or fields within the information elements which are not mapped across the FP to the GSM network shall either be ignored or processed locally as defined in this ETS, GAP, ETS 300 175 parts 1 to 8 [1] to [8] if not covered by ETS 300 444 [9], or the relevant GSM specification.

The general philosophy of describing the MM interworking procedures takes place as follows:

- a) the procedure description describes the interworking procedures in the FP. In the procedures, references are made to subclauses relating to messages, information elements or fields within the information elements which are mapped across the interworking unit;
- b) if no mappings are defined for data at the DECT air interface which is being received or sent (as being mandatory for the GAP or this ETS) the handling of this data is described in the procedure itself. If not, the data shall be either ignored or, if covered by GAP, shall be processed accordingly;
- c) if no mappings are defined for data described in the associated GSM specification (ETS 300 557 [21] (GSM 04.08) or ETS 300 590 [23] (GSM 08.08)) which is being received or sent at reference point A in normal GSM usage, the handling of this data is described in the procedure itself. If not, the processes relating to the received or sending events of this data is outside the scope of this ETS.

The general layout of the procedures is described in figure 15.

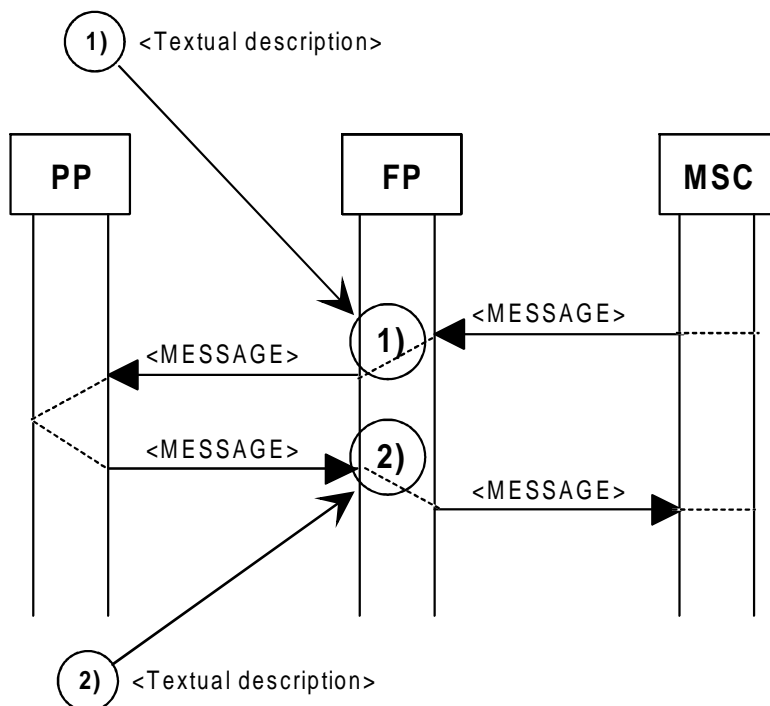

Figure 15: An example of a layout of the FP interworking procedures

6.1.2.1 Authentication procedure

- 1) Upon receipt of a Authentication request message (figure 16) from the MSC as a result of a GSM authentication procedure as described in ETS 300 557 [21] (GSM 04.08) the FP IWU shall issue a MM\_AUTHENTICATE-req primitive to the FT initiating the DECT PT authentication procedure by sending a {AUTHENTICATION-REQUEST} message to the PT. The mapping of the GSM Authentication request message to the DECT {AUTHENTICATION-REQUEST} message is shown in subclause 6.1.6.1.1. The mapping of GSM cipher key sequence number to DECT authentication type is described in subclause 6.1.7.1.3

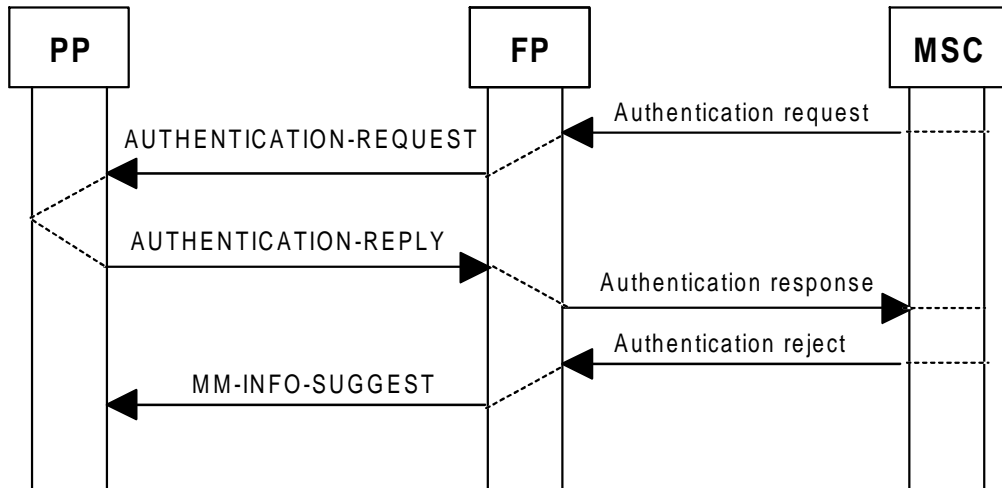

Figure 16: Authentication procedure

The fields in the <<AUTH-TYPE>> information element that are generated locally for DECT use shall have the values shown in table 3. The full mapping is described in subclause 6.1.7.1.3.

Table 3

Information element/Item number	Field	Value
<<AUTH-TYPE>>		
1	<Authentication algorithm identifier>	"01000000"B (GSM authentication algorithm)
2	<Authentication key type>	"0001"B (User authentication key)
3	<Authentication key number>	"0000" (Key associated to the active IPU)
4	<INC bit>	"0"B
5	<TXC>	"0"B (Do not include the derived cipher key in {AUTHENTICATION-REPLY})
6	<UPC bit>	"1"B (Store cipher key)

- 2) Upon receipt of a MM\_AUTHENTICATE-cfm primitive from the FT as a result of a received {AUTHENTICATION-REPLY} message from the PT the FP IWU shall send a Authentication response message to the MSC.

The mapping of the DECT {AUTHENTICATION-REPLY} message to the GSM Authentication response message is shown in subclause 6.1.6.2.3.

If the {AUTHENTICATION-REJECT} message is received from the PT or timer <MM-auth-1> in the FT expires i.e. {AUTHENTICATION-REPLY} has not been received from the PT, the FP IWU receives a MM\_AUTHENTICATE-cfm primitive indicating a failure and does not take any further action.

When a Authentication reject message is received from the MSC this shall be mapped to a {MM-INFO-SUGGEST} message in DECT FT coding "GSM authentication of PP failure". On receipt of such a message in the relevant primitive the PP-IWU shall delete GSM LAI, TMSI and Cipher key sequence number from the SIM/DAM GA. Mapping between the GSM Authentication reject message and the DECT {MM-INFO-SUGGEST} is shown in subclause 6.1.6.1.2.

### 6.1.2.2 Identity procedure

- 1) Upon receipt of a Identity request message (figure 17) from the MSC as a result of a GSM identification procedure as described in ETS 300 557 [21] (GSM 04.08) the FP IWU shall issue a MM\_IDENTITY-req primitive to the FT initiating the DECT Identification of PT procedure by sending a {IDENTITY-REQUEST} message to the PT. The mapping of the received GSM Identity request message to the DECT {IDENTITY-REQUEST} message is shown in subclause 6.1.6.1.3.

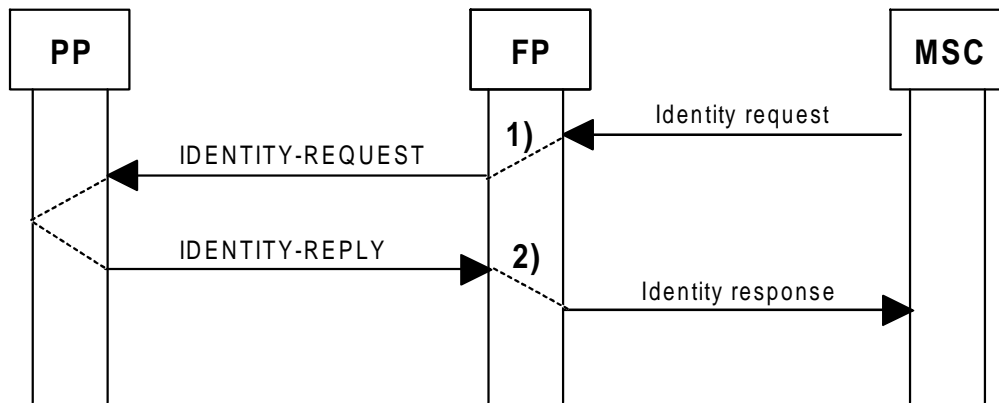

Figure 17: Identity procedure

- 2) Upon receipt of MM\_IDENTITY-cfm primitive from the FT the FP IWU shall send a Identity response message to the MSC. The mapping of the DECT {IDENTITY-REPLY} message to the GSM Identity response message is shown in subclause 6.1.6.2.7.

If the {IDENTITY-REPLY} message contains no information element (meaning of identity request rejection) or if the timer <MM-ident-2> expires in the FT i.e. {IDENTITY-REPLY} message has not been received from the PT, the FP IWU, upon receipt of MM\_IDENTITY-cfm primitive from the FT indicating a failure shall terminate the procedure. Any further actions in the FP IWU are implementation dependant.

### 6.1.2.3 Location registration related procedures

This subclause covers three different types of GSM procedures relating to location registration.

These are:

- a) normal location updating;
- b) periodic location updating;
- c) attach procedure.

Table 4 defines which type of location updating (a, b, or c) the FP IWU shall perform towards the GSM network relating to conditions listed in table 4 (see note 1).

**Table 4: GSM network specific functions in the FP IWU after receiving a {LOCATE-REQUEST} message from the PP**

Detach performed previously	The received <Extended location information> received from the PP equivalent to the LAI associated to the RFP	Function in the FP IWU	NOTE
YES	YES	Perform attach procedure	If attach allowed by the GSM PLMN (O&M)
YES	NO	Perform normal location updating procedure	
NO	YES	Perform periodic location updating procedure	
NO	NO	Perform normal location updating procedure	

O&M: Operations and Maintenance

NOTE 1: Change of DECT location areas in the same GSM location area may initiate a GSM related periodic location registration procedure as described in this subclause. The FP may not be able to distinguish a location registration caused by a change of the DECT location area from a periodic location registration.

In the context of this ETS the different types of functions in the FP IWU are defined in table 5.

**Table 5: Relation of <<Location updating type>> information element value to the functions listed for the FP IWU**

Location updating type	<<Location updating type>> information element value in the Location updating request message to the MSC
Normal location registration	"Normal location updating"
Periodic location registration	"Periodic updating"
Attach procedure	"IMSI attach"

- 1) Upon receipt of MM\_LOCATE-ind primitive from the FT as a result of a received {LOCATE-REQUEST} message from the PT (figure 18) the FP IWU shall initiate a GSM location registration procedure as described in ETS 300 557 [21] (GSM 04.08) by sending a Location updating request message to the MSC. The mapping of the DECT {LOCATE-REQUEST} message to the GSM Location updating request message is shown in subclause 6.1.6.2.1.

In overload situations, the FP IWU may reject the location registration immediately by sending a MM\_LOCATE-res primitive with a reject parameter. In this case the primitive shall include a <<DURATION>> information element to indicate a time period in which the PP will not be allowed to re-attempt a location registration within this DECT LA. The PP shall support the <<DURATION>> information element in the {LOCATE-REJECT} message. The value may be based on defined time limit 1 or 2 (see ETS 300 175-5 [5] or the standard time limit, see subclause 6.1.6.1.6.

The <<Mobile station classmark 1>> information element shall be forwarded by the FT IWU to the MSC.



Table 8: Field values for Mobile station classmark 2

Information element coding DECT	DECT value	Information element coding GSM	GSM value
-	-	Mobile station classmark 2	"0100"B for GSM.
-	-	Revision level	=01B
-	-	A5/1	=0 Encryption algorithm A5/1 available.
-	-	RF power capability	=010 Class 3
-	-	PS capability	=0 PS capability not present
-	-	Supplementary Service (SS) screening indicator	=01 capability of handling ellipses notation and phase 2 error handling
Terminal capability	Profile Indicator_2=GSM SMS service	Short message (SM) capability	note
-	-	Frequency capability (FC)	=0 The mobile station does not support the extension band G1 in addition to the primary GSM band
-	-	Classmark 3 (CM3)	=0 No additional MS capability information available.
-	-	A5/3	=1 Encryption algorithm A5/3 available.
-	-	A5/2	=1 Encryption algorithm A5/2 available.
NOTE: The value of SM capability is received in the <Profile Indicator_2> field. (0=SM capability not present, 1=SM capability present)			

The requirements in the following paragraphs relating to location updating rejection is mandatory in ARI class D environment, where as in ARI class A, B and C environments these are optional and, for example, the access rights terminate procedures may be used.

- 3) Upon the reception of the MM-IDENTITY\_ASSIGN-cfm primitive, in the case when a new TMSI has been allocated to the PP by sending the <<NETWORK ASSIGNED IDENTITY>> the FP IWU shall send a TMSI reallocation complete message to the MSC. If a Temporary Portable User Identity (TPUI) assignment has taken place without TMSI (valid value) allocation the procedure shall terminate at the FP IWU.

If the timer <MM-ident-1> supervizing the reception of {TEMPORARY-IDENTITY-ASSIGN-ACK} message from the PT expires, the FP IWU upon reception of a MM\_IDENTITY\_ASSIGN-cfm primitive indicating a failure shall terminate the procedure. Any further actions in the FP IWU are implementation dependant.

Upon receipt of a Location updating rejected message from the network after sending the Location request message to the MSC see figure 19 the FP IWU shall issue a MM\_LOCATE-res with a reject parameter being set. The FT sends a {LOCATE-REJECT} message to the PT. The mapping of the Location updating rejected message to the {LOCATE-REJECT} message is shown in subclause 6.1.6.1.7.

If the reject cause in the Location updating reject message includes a cause value "Location area not allowed" or "National roaming not allowed in this LA", and the DECT location areas do not correspond to the GSM location areas, the FP IWU shall initiate a location updating procedure by issuing a MM\_INFO\_SUGGEST-req primitive to the FT to re-initialize the DECT location area level of the PP to correspond to the forbidden GSM LAI. If the reject cause in the Location updating accept message from the MSC includes the cause value "PLMN not allowed" the FP IWU may initiate a location updating procedure by issuing a MM\_INFO\_SUGGEST-req primitive to the FT in order to re-initialize the DECT location area level of the PP to correspond to an appropriate level.

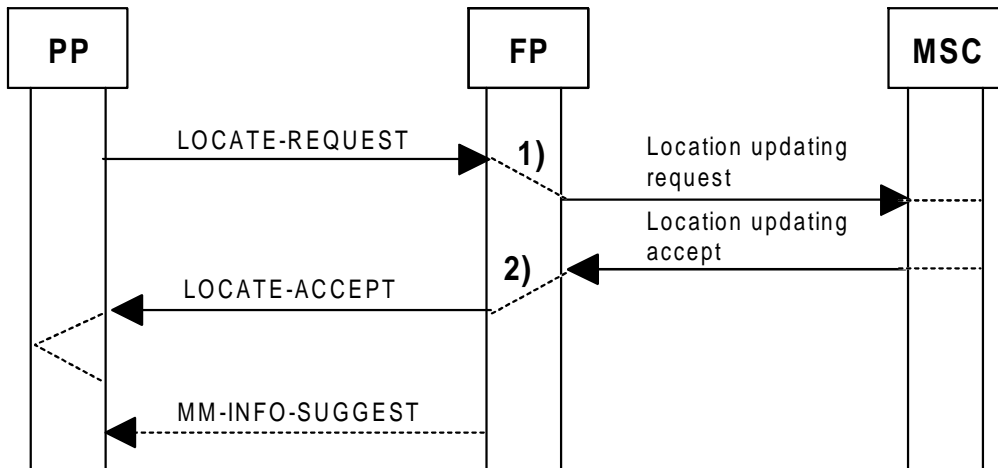

Figure 19: Location registration reject

The FP shall have knowledge of which DECT location area level corresponds the GSM LAI. The re-initialization of the DECT location area level is needed in order to avoid the PP initiating an unnecessary location updating procedure in the current GSM LAI/PLMN.

6.1.2.4 Detach procedure

- 1) Upon receipt of MM\_DETACH-ind primitive from the FT as a result of a received {DETACH} message from the PT (figure 20), the FP IWU shall send a IMSI detach indication message to the MSC. The mapping of the DECT {DETACH} message to the GSM IMSI detach indication message is shown in subclause 6.1.6.2.4.

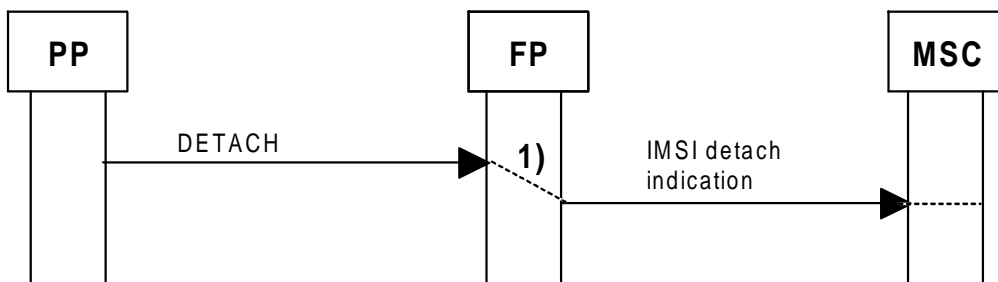

Figure 20: Detach procedure

6.1.2.5 Temporary identity assignment procedures

- 1) Upon receipt of a TMSI reallocation command from the MSC (figure 21) as a result of a GSM TMSI re allocation procedure defined in ETS 300 557 [21] (GSM 04.08), the FP IWU shall issue a MM\_IDENTITY\_ASSIGN-req primitive to the FT initiating the temporary identity assignment procedure by sending a {TEMPORARY-IDENTITY-ASSIGN} message to the PT as described in ETS 300 175-5 [5]. The mapping of the GSM TMSI reallocation command message to the DECT {TEMPORARY-IDENTITY-ASSIGN} message is shown in subclause 6.1.6.1.4.



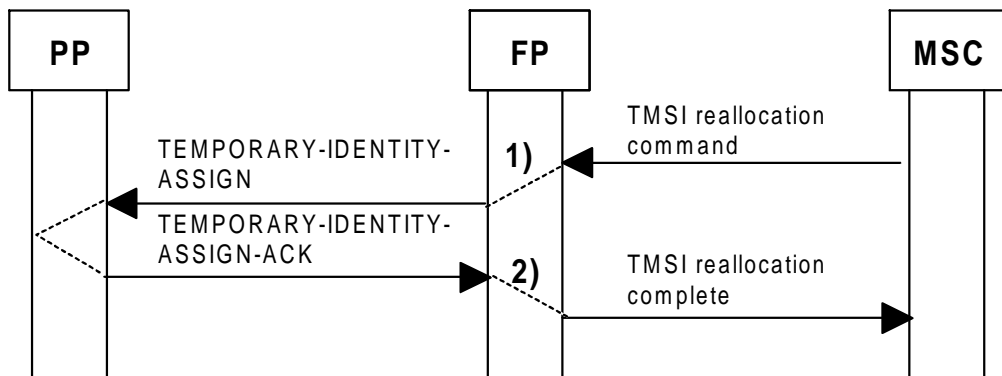

Figure 21: TMSI reallocation procedure

If the PP is required to initiate the periodic location registration, the FT shall send a <<DURATION>> information element, which is only applied for the DECT TPUI.

NOTE: Rules for TPUI assignment in relation to DECT location areas as described in GAP are applied.

- 2) Upon receipt of a MM\_IDENTITY\_ASSIGN-cfm primitive as a result of a received {TEMPORARY-IDENTITY-ASSIGN-ACK} message from the PT the FP IWU shall send a TMSI-reallocation complete message to the MSC. The mapping of the DECT {TEMPORARY-IDENTITY-ASSIGN-ACK} message to the GSM TMSI reallocation complete message is shown in subclause 6.1.6.2.5.

If the PT sends a {TEMPORARY-IDENTITY-ASSIGN-REJ} or timer <MM-ident-1> expires in the FT reflecting in FP IWU receiving a MM\_IDENTITY\_ASSIGN-cfm primitive indicating "rejection" the procedure shall be terminated in the FP IWU, see figure 22. Any further actions in the FP IWU are implementation dependant.

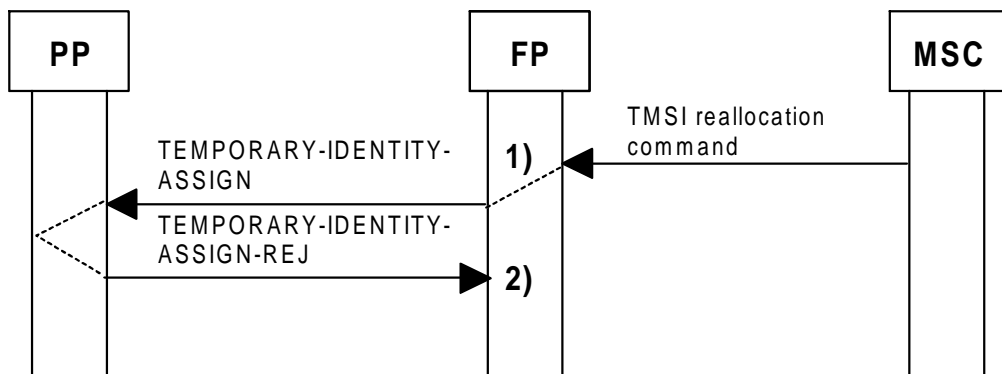

Figure 22: TMSI reallocation procedure rejection from PT

6.1.2.6 Cipherng procedure

- 1) Upon receipt of a Cipher mode command from the MSC as described in ETS 300 590 [23] (GSM 08.08) the FP IWU shall issue a MM\_CIPHER-req primitive to the FT (figure 23) which initiates the ciphering procedure by sending a {CIPHER-REQUEST} message to the PT.

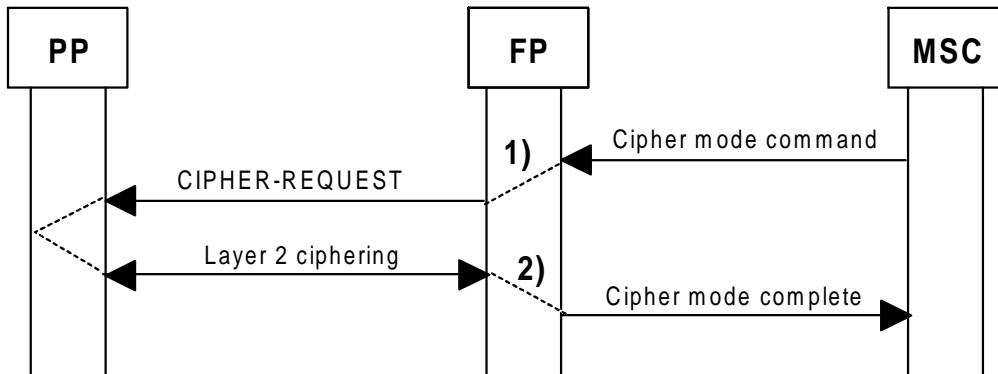

Figure 23: Cipherng procedure

The mapping of the GSM Cipher mode command message to the DECT {CIPHER-REQUEST} message is shown in subclause 6.1.6.1.5.

The received <<Encryption information>> in the Cipher mode command message shall be used as follows:

- a) the received <Key> field is used by the FP in order to generate the DECT Cipher Key (CK) as described in annex A. The calculated CK shall be used for DSAA ciphering;
- b) the <<CIPHER-INFO>> information element field values (except <Y/N bit>) shall be set as follows: <Cipher key number> field value shall be the same one as received during a previous DECT location registration, paging, PP initiated call establishment procedure or the value given from the MSC during a previous authentication procedure depending on which one has been performed latest.

Other fields in the <<CIPHER INFO>> information element shall be set to the values shown in table 9.

Table 9: Field values for <<CIPHER INFO>>

Information element/Item number	Field	Value
<b>&lt;&lt;CIPHER INFO&gt;&gt;</b>		
1	<Cipher algorithm identifier>	"0000001"B (DECT standard cipher algorithm 1)
2	<Proprietary algorithm identifier>	Not sent
3	<Cipher key type>	"1001" (Derived cipher key)

- 2) Upon receipt of a layer 2 acknowledgement the FP IWU shall send a Cipher mode complete message as defined in ETS 300 590 [23] (GSM 08.08) to the MSC (figure 23).

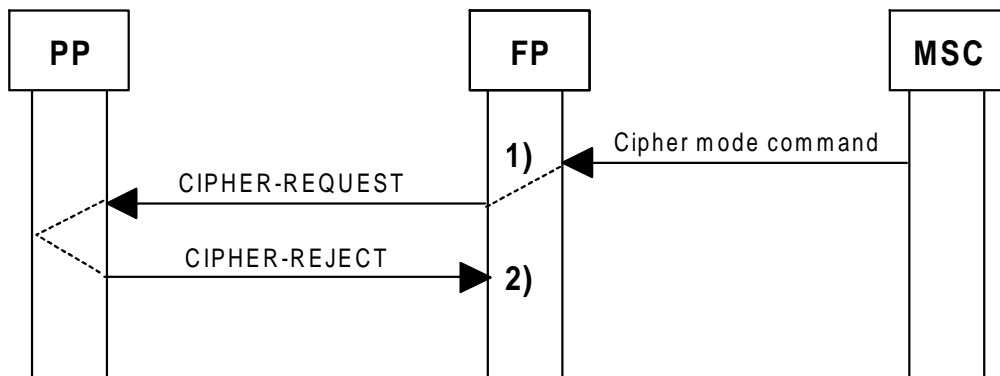

**Figure 24: Ciphering procedure - rejection**

The PT may reject ciphering (see figure 24):

- 1) as above;
- 2) on receipt of a MM\_CIPHER-cfm primitive indicating "reject" triggered by a PT {CIPHER-REJECT} message, the procedure shall be terminated at the FP IWU;
- 3) on receipt of MM\_CIPHER-cfm primitive indicating a failure resulting from the timeout of <MM-cipher-1> timer, the procedure shall be terminated at the FP IWU.

When the procedure is terminated due to timer expiry or reception of a {CIPHER-REJECT} message, other actions are possible and are implementation dependant. Radio connections may be released.

#### 6.1.2.7 CM service procedure

This procedure is associated to the initialization of the GSM connection management entity in order to allow the usage of the GSM CC.

**NOTE:** The CM service procedure is a GSM specific procedure in order to establish a lower layer Connection Management (CM) service to the upper GSM Connection Management (CM) sub-layers such as the CC entity. The DECT CC ({CC-SETUP} message) entity in this case is used to initiate the CM service procedure as well as the Call establishment procedure as defined in subclause 6.1.1.1, i.e. the CM service procedure is an intermediate event prior to proceeding with the normal Call establishment procedure between the PP and the MSC. Thus, even though initiated by the DECT {CC-SETUP} message, it is in principle invisible to the end-to-end CC related events.

Upon receipt of a CM-service accept or an indication from the FT for the successful completion of the ciphering procedure initiated the MSC, one of the following events shall occur in the FP IWU (a or b):

- a) No dialling information was received in the {CC-SETUP} from the PT, i.e. the <<CALLED-PARTY-NUMBER>> information element was not included:
  - 1) upon receipt of MNCC\_SETUP-ind primitive from the FT as a result of a received {CC-SETUP} message from the PT (figure 25) the FP IWU shall initiate a GSM CM service procedure as described in ETS 300 557 [21] (GSM 04.08) by sending a CM service request message to the MSC. The mapping of the DECT {CC-SETUP} message information elements to the GSM CM Service request message is shown in subclause 6.1.6.2.6. The CM Service request message shall contain the MS Classmark 2 information element previously stored by the FP IWU (see subclause 6.1.2.3, table 8);
  - 2) the FP IWU shall issue a MNCC\_SETUP\_ACK-req primitive and this shall result in a {CC-SETUP-ACK} message being sent to the PT, (figure 25) as described in subclause 6.1.1.1 (a). The mapping of GSM CM-service accept message and the DECT {CC-SETUP-ACK} message is shown in subclause 6.1.6.1.25.

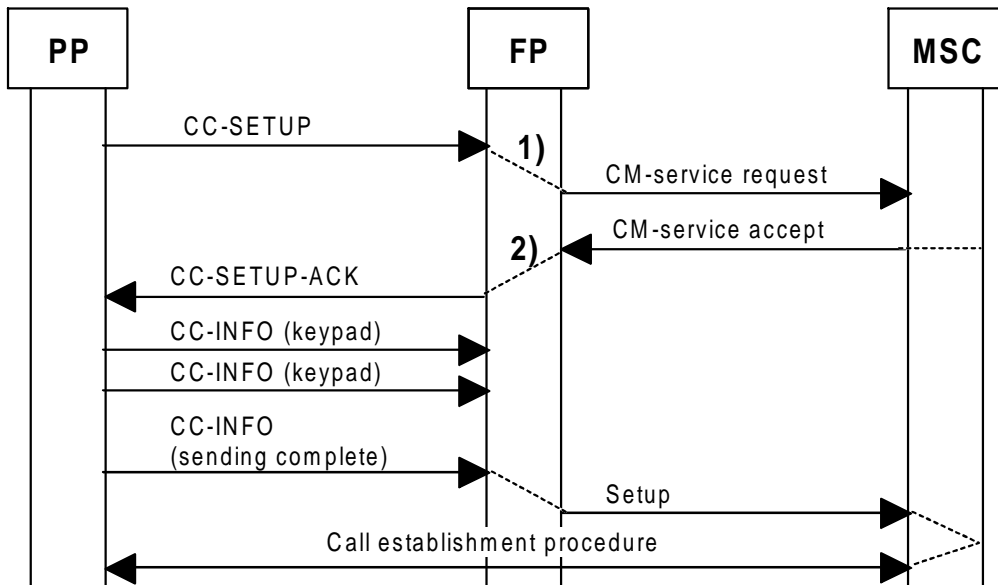

**Figure 25: CM service procedure, dialling info in {CC-INFO}, no authentication or ciphering procedure**

If the Cipher mode command message is received from the MSC it is considered as an implicit CM service request acknowledgement. The FP IWU shall only interpret the procedure as terminated when it has received an acknowledgement from the FT of successful ciphering and it has sent a Cipher mode complete to the MSC. The {CC-SETUP-ACK} message to the PT is then locally generated by the FT (figure 26).

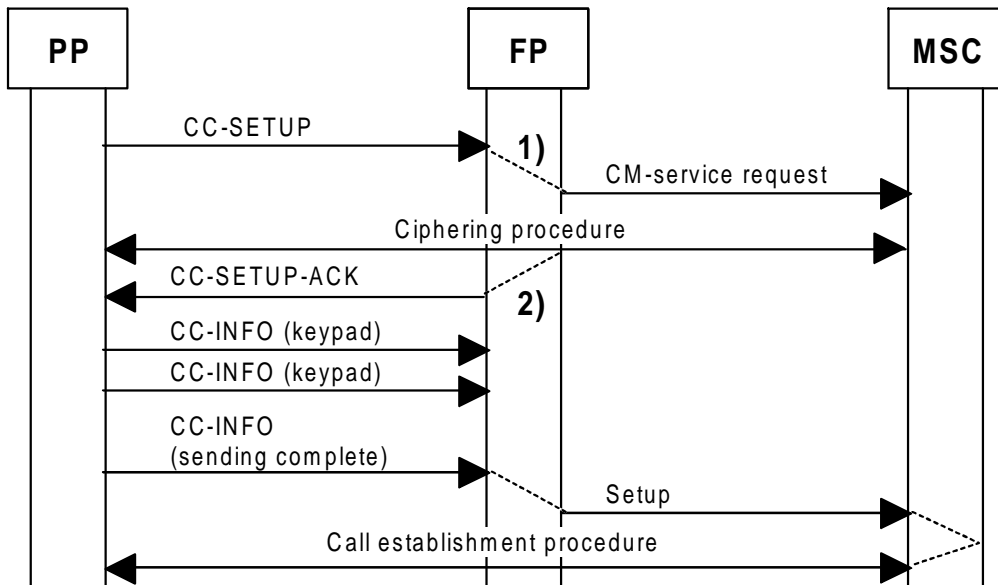

**Figure 26: CM service procedure, dialling info in {CC-INFO}**

Upon receipt of dialling information the FP IWU shall initiate the GSM Call establishment procedure as defined in ETS 300 557 [21] (GSM 04.08) by sending a Setup message (deriving the necessary information from the {CC-SETUP} message and one or several {CC-INFO} messages) to the MSC and proceed with the call establishment procedure as defined in subclause 6.1.1.1.

- b) Dialling information was received in the {CC-SETUP} from the PT, i.e. the <<CALLED-PARTY-NUMBER>> information element was included:
- 1) upon receipt of MNCC\_SETUP-ind primitive from the FT as a result of a received {CC-SETUP} message from the PT (figure 27) the FP IWU shall initiate a GSM CM service procedure as described in ETS 300 557 [21] (GSM 04.08) by sending a CM service request message to the MSC. The mapping of the DECT {CC-SETUP} message information elements to the GSM CM Service request message is shown in subclause 6.1.6.2.6. The CM Service request message shall contain the MS Classmark 2 information element previously stored by the FP IWU (see subclause 6.1.2.3, table 8);
  - 2) the FP IWU shall initiate the GSM Call establishment procedure as defined in ETS 300 557 [21] (GSM 04.08) by sending a Setup message (deriving the necessary information from the same {CC-SETUP} message) to the MSC and proceed with the call establishment procedure as defined in subclause 6.1.1.1 (b).

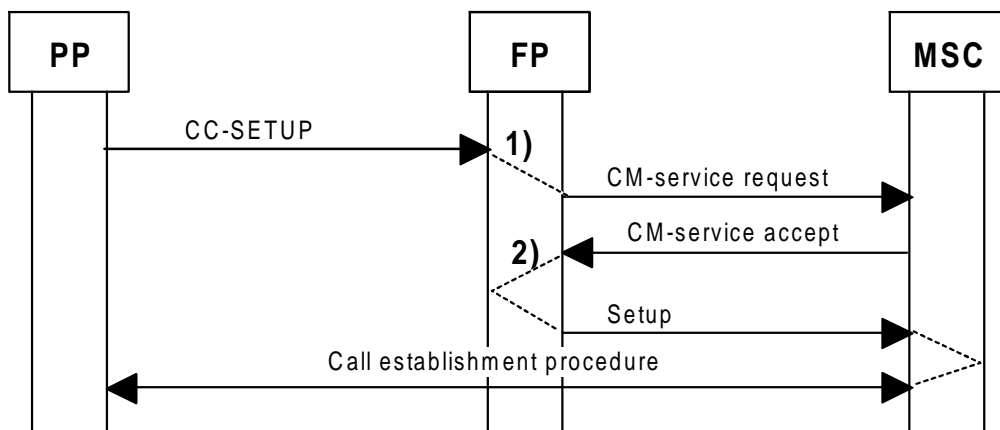

**Figure 27: CM service procedure, dialling info in {CC-SETUP}, no authentication or ciphering procedure**

If the Cipher mode command message is received from the MSC it is used as an implicit CM service request acknowledgement. The FP IWU shall interpret the procedure as terminated only when it has received an acknowledgement from the FT of successful ciphering and it has sent a Cipher mode complete to the MSC (figure 28).

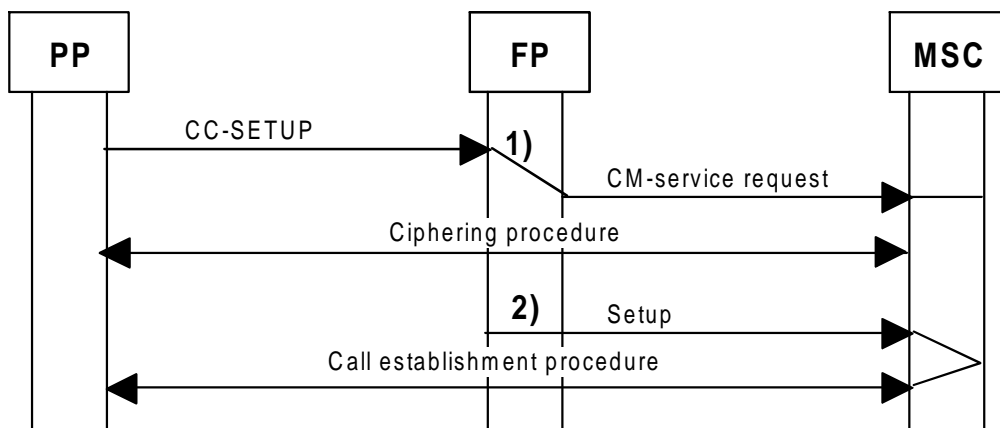

**Figure 28: CM service procedure, dialling info in {CC-SETUP}**

Upon receipt of dialling information the FP IWU shall initiate the GSM Call establishment procedure as defined in ETS 300 557 [21] (GSM 04.08) by sending a Setup message (deriving the necessary information from the same {CC-SETUP} message) to the MSC and proceed with the call establishment procedure as defined in subclause 6.1.1.1.

To prevent the PT CC state machine of timing out due to eventual delay caused by the implementation of some GSM specific procedures before answering to PT the Lower Layer Management Entity (LLME) shall have the possibility of requesting FT to send the {CC-NOTIFY} message with <<TIMER RESTART>> information element, thereby restarting the PT CC timer.

#### 6.1.2.8 CM service procedure abnormal cases

If at any time FP IWU receives the CM SERVICE REJECT as an answer to the CM SERVICE REQUEST, it shall send a MNCC\_REJECT-req reflecting in a {CC-RELEASE-COM} being sent to the PT carrying an appropriate release reason.

If the FP IWU receives a CM service reject message with a cause value "IMSI unknown to VLR" after the CC release has been accomplished it shall initiate location update, see subclause 6.1.2.3.

The PT may decide to release the setup immediately after the {CC-SETUP} has been sent sending a {CC-RELEASE} message to the FT reflecting in a MNCC\_RELEASE-ind primitive to the FP IWU, see subclause 6.1.1.4. Timer P<CC.03> may expire enforcing PT to send {CC-RELEASE-COM} message to the FT reflecting in a MNCC\_REJECT-ind primitive to the FP IWU, see subclause 6.1.1.6 case b). In all these cases the FP IWU shall send a CM SERVICE ABORT message any time after the completion of the RR connection and not after the first CC message (e.g. SETUP) is sent.

The MSC may, at any time, send an Abort message (see ETS 300 557 [21] (GSM 04.08), subclause 4.3.5). If the FP IWU receives Abort message before it has sent the Setup to the MSC the FP IWU shall send a MNCC\_REJECT-req reflecting in a {CC-RELEASE-COM} being sent to the PT carrying an appropriate release reason.

The FP IWU shall supervise the acknowledgement from the MSC of the CM SERVICE REQUEST message (CM SERVICE ACCEPT, CIPHER MODE COMMAND or CM SERVICE REJECT). When the timer expires, the FP IWU shall issue a MNCC\_REJECT-req primitive reflecting in a {CC-RELEASE-COM} message being sent to the PT carrying an appropriate release reason.

#### 6.1.2.9 External handover procedure

External Handover is the process of switching a call in progress from one Fixed Radio Termination (FP-1) to another Fixed Radio termination (FP-2) as defined in ETS 300 175-5 [5]. In the respect of this ETS the procedure is mapped to the MSC associated handover procedures as defined below. See figure 30 for an overview of DECT/GSM external handover. This procedure is based on the procedures in ETS 300 175-5 [5] and ETS 300 590 [23] (GSM 08.08). The modifications to the defined procedures are as described in this subclause.

FP specific behaviour is described in this subclause. The PP specific behaviour is described in subclause 6.3.2.7.

##### 6.1.2.9.1 General description

Prior to initiation of external handover, the PP should obtain handover candidates from the current FP-1. This enables the PP to determine to which FPs an external handover may be attempted.

The PP measures the quality of the received signal strength from the external handover candidate(s) (FP-2(s)) and compares the received link quality with the currently used link. Upon detection of a better link, the PP may decide to perform an external handover.

The PP shall request from the FP-1 a handover reference. This request implicitly informs the FP-1 that an external handover is about to take place. The request contains information to what target cell has been chosen as most appropriate. As a result of this indication, the FP-1 shall request for a handover attempt by signalling to the MSC.

The MSC should allocate the network resources needed at the terrestrial links as well as in the handover candidate FP-2. Upon successful completion of the resource allocation, the MSC should inform the FP-1 that resources were allocated and the handover attempt may continue. The FP-1 shall return the previously requested information to the PP which shall then initiate a setup to the handover candidate FP-2.

If ciphering is required, the PP shall request ciphering on the new link as soon as possible after handover is accepted by the PP. The FP-2 shall also perform a connect procedure in order to switch the DECT U-Plane from the FP-1 to the FP-2.

With a successful connect procedure, the FP-2 shall inform the MSC about the handover in the access part. As a result, the MSC switches the network connection to the FP-2 and initiate a release of the link to the FP-1.

#### 6.1.2.9.2 Handover candidate procedure

The external handover candidate information is obtained using two sub-procedures, handover candidate indication, and/or handover candidate retrieval as defined in subclause 15.7.1 of the ETS 300 175-5 [5].

Handover candidate indication, initiated by FP, shall be handled as defined in subclause 15.7.1.2 of ETS 300 175-5 [5].

Handover candidate retrieval, initiated by the PP, shall be handled as defined in subclause 15.7.1.3 of ETS 300 175-5 [5].

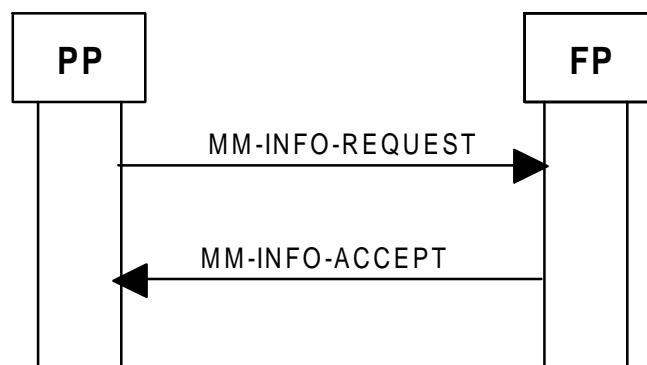

Figure 29: Handover candidate retrieval procedure

#### 6.1.2.9.3 Handover required indication

As a result of the request for a handover reference by PP using the {MM-INFO-REQUEST} message (see subclause 6.3.2.7.2), FP-1 sends the Handover Required message to the MSC with the 'proposed external handover candidate(s)' included in the Cell Identifier List information element. The detailed mapping of {MM-INFO-REQUEST} message to Handover Required message is defined in subclause 6.1.6.2.20.

The Handover Required message may not result in a Handover Command Message. In this case the "Response Request" information element will, if present, indicate that the FP/IWU requires an indication.

#### 6.1.2.9.4 Handover resource allocation

The MSC requests for resource allocation in the handover candidate FP-2 using the Handover Request message. When resources are allocated, FP-2 shall indicate this to the MSC with the Handover Request Acknowledge message. The message shall include a 'network handover reference' and 'fixed identity' of target cell in order to identify the reserved resources. This information is passed in the Layer 3 Information IE utilizing the Handover Command RR message. The unique coding in this ETS of the Handover Command RR message is shown in table 10.

**Table 10: DECT/GSM interworking profile unique coding of the handover command RR message**

<b>Handover Command RR Message coding</b>	<b>Clarification</b>
RR Management Protocol Discriminator	See ETS 300 557 [21] (GSM 04.08)
Skip Indicator	See ETS 300 557 [21] (GSM 04.08)
Handover Command Message Type	Shall indicate Handover Command Message Type, see ETS 300 557 [21] (GSM 04.08)
Fixed Identity	Contains the fixed identity of the selected target cell, coded according to DECT Base standard, see ETS 300 175-5 [5] subclause 7.7.18
Network Parameter:	New field added, used to carry 'network handover reference', coded according to DECT Base standard, see ETS 300 175-5 [5] subclause 7.7.29
ID for Network Parameter	
Length of element	
Discriminator	Shall indicate 'Handover Reference, GSM network'
Data	Handover reference, coded using binary representation.

**6.1.2.9.5 Handover execution by FP**

The MSC informs the FP-1 that network resources have been allocated and that the handover procedure may continue. This is carried out by utilizing the Handover Command message that transparently transfers the 'network handover reference' and selected 'target cell' as a Layer 3 Information IE with the Handover Command RR message. This message shall then be mapped to the {MM-INFO-ACCEPT} message as defined in subclause 6.1.6.1.26.

**6.1.2.9.5.1 Handover request to FP-2**

When FP detects handover setup from the PP indicating 'external handover call setup', the FP-2 is able to correlate the PP setup attempt to the previously reserved network resources. This is made using the 'network handover reference' received in the {CC-SETUP} message. FP-2 shall indicate to the network that the handover is detected by sending a Handover Detect message to the MSC. This message is used to initiate switching of the network resources to the new link. For detailed mapping of {CC-SETUP} message to Handover Detect see subclause 6.1.6.2.21.

For every 'network handover reference', the FP-2 shall send only one Handover Detect message. Any additional {CC-SETUP} message using the same 'network handover reference', as a result of multiple transactions active on same PP, shall not be interworked and mapped to the GSM Handover Detect message.

**6.1.2.9.5.2 Handover confirm by FP-2**

The FP-2 shall send a {CC-CONNECT} message to the PP, to indicate confirmation of the external handover by the network.

**6.1.2.9.5.3 Cipherng procedure**

Cipherng shall be initiated by PP as soon as possible after receipt of {CC-CONNECT} message. Cipherng shall occur prior to returning {CC-CONNECT-ACK} message. The cipherng procedure for external handover shall be initiated by the PP as defined in the ETS 300 175-5 [5] subclause 15.7.6.



#### 6.1.2.9.5.4 Handover completion

When the FP-2 receives {CC-CONNECT-ACK} message it shall send the Handover Complete message to the MSC indicating that handover is completed in the access part. The mapping between the {CC-CONNECT-ACK} message and the Handover complete message is shown in subclause 6.1.6.2.22. The receipt of Handover complete is used by the MSC to initiate the release of the old link.

For each 'network handover reference', the FP-2 shall send only one Handover Complete message. Any subsequent {CC-CONNECT-ACK} messages related to the same 'network handover reference', as a result of multiple transactions active on same PP, shall not be interworked and mapped to the GSM Handover Complete message.

The Handover Complete message will trigger the MSC to initiate the release of the old link and the associated resources. The MSC shall send the Clear Command message with cause 'handover successful' to the FP-1. Upon receipt of this message a normal call release shall occur, using the {CC-RELEASE} message (s). The mapping between the Clear command message and the {CC-RELEASE} message is shown in subclause 6.1.6.1.27.

When the release of PP resources is completed, the PP will send the {CC-RELEASE-COM} message(s) to the FP-1. The Clear Complete message is sent by the FP-1 to the MSC to indicate the release of terrestrial resources and to initiate the release of the BSSAP SCCP connection associated with the dedicated resource.

NOTE: This release is based on the 'late release' as defined in ETS 300 175-5 [5]. If 'early release' is used by the PP, FP-1 performs the release of the old connection according to ETS 300 175-5 [5]. In this case the FP-1 will not initiate release to the PP upon receipt of Clear Command from the MSC. The network procedures will be equal for both types of releases.

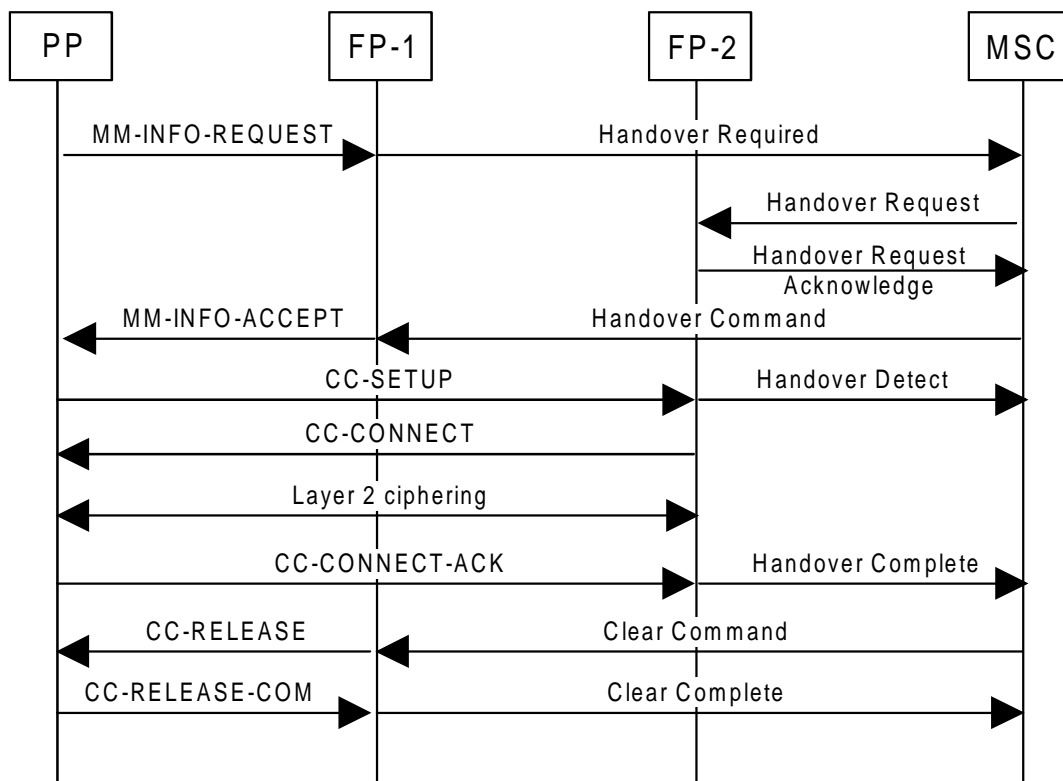

Figure 30: DECT/GSM interworking profile external handover overview

#### 6.1.2.9.5.5 Sequence number handling

To secure that the sequence number of the next sequenced numbered message to be sent is accepted by the MSC, the FP IWU shall, after the completion of the external handover procedure, but prior to sending any subsequent MM or CM message using SAPI=0 to the MSC, choose a send sequence number and initiate the status enquiry procedure towards the MSC.

When the status enquiry procedure is used for this purpose, the first expiry of timer T322 (see ETS 300 557 [21] (GSM 04.08), subclause 5.5.3.1) shall not cause clearing of the call. If non of the transactions affected by the external handover is a CC transaction (see subclause 6.3.2.7.8), the TI used when initiating the status enquiry procedure is assigned by the FP IWU. This temporary transaction shall be released either at expiry of timer T322 or at reception of a Release complete message for this transaction. After the first sent Status enquiry message the send sequence number handling shall be performed as specified in ETS 300 557 [21] (GSM 04.08), subclause 3.1.4.3.

#### 6.1.2.9.6 Handover reject

##### 6.1.2.9.6.1 Handover reject by PP

If PP decides to not complete an initiated handover attempt, PP should send {MM-INFO-REQUEST} message indicating "handover failed, reversion to old channel".

NOTE: The PP may reject handover completion at any time prior to sending the {CC-CONNECT-ACK} message to the FP-2.

After returning a {MM-INFO-ACCEPT} message as a confirmation to a previous {MM-INFO-REQUEST} message, the FP-1 shall generate a Handover Failure message as defined in subclause 6.1.6.2.23. This will initiate the reversion of the network resources to the old channel. It will also initiate the release of the FP-2 resources allocated by MSC sending Clear Command to FP-2 with cause 'radio interface failure, reversion to old channel'.

If the FP-2 receives a Clear Command message from the MSC the FP-2 shall, prior to returning Clear Complete message to the MSC, release any assigned terrestrial resources. If dedicated radio resources were assigned, they shall be released using a normal call release of the transaction(s) using {CC-RELEASE} message (s). See subclause 6.1.6.1.27. At the completion of the release of the new link, FP-2 will receive a {CC-RELEASE-COM} message from the PP.

##### 6.1.2.9.6.2 Handover reject by FP-1

The PP Handover reference retrieval can be rejected by FP-1 prior to initiating the Handover Required indication to the MSC. The FP-1 shall then reject the Handover reference retrieval by sending {MM-INFO-REJECT} message to the PP. A precondition for external handover is that a call is in an 'active call state' (see ETS 300 175-5 [5]). Otherwise the external handover shall be rejected as defined above.

If a Handover Required Reject message is received from the MSC, the FP-1 shall generate a {MM-INFO-REJECT} message to the PP to reject the Handover Reference Retrieval. The mapping of the Handover Required Reject message to the {MM-INFO-REJECT} message is shown in subclause 6.1.6.1.28.

##### 6.1.2.9.6.3 Handover reject by FP-2

If the FP-2 is unable to comply to the resource allocation initiated by a Handover Request message from the MSC, the FP-2 shall generate a Handover Failure message to the MSC. The FP-2 is also responsible to release all resources assigned to the FP-2.

##### 6.1.2.9.6.4 Handover reject by MSC

If the MSC is not able to allocate resources for a Handover Required indication (i.e. the Handover Required message does not result in Handover Command message to FP-1), it may respond to FP-1 with a Handover Required Reject message. This is only applicable if requested in the Handover Required message.

### 6.1.2.9.7 Support of external handover due to O&M activities

GSM leaves the possibility to initiate a handover for internal O&M reason, e.g. during replacement of hardware. The support for this functionality in the respect of this ETS is provided by utilizing the existing procedures defined in the ETS 300 175-5 [5] as follows:

- Upon receipt of Handover Command message from the MSC, without previously requested external handover, the FP may initiate an external handover by sending a {MM-INFO-SUGGEST} message to the PP as described in subclause 15.7.3 of ETS 300 175-5 [5]. The mapping of Handover Command message to {MM-INFO-SUGGEST} message is shown in subclause 6.1.6.1.29.

### 6.1.2.9.8 Handling of transaction identifiers during and after external handover

FP shall support Transaction Identifier (TI) and Extended Transaction Identifier (ETI) during and after external Handover as defined in subclause 6.3.2.7.8

### 6.1.3 Paging related IWU procedure

- 1) Upon receipt of a paging message from the MSC (figure 31) as a result of a paging procedure as defined in ETS 300 590 [23] (GSM 08.08) the FP IWU shall initiate the DECT indirect (paged) FT initiated link establishment procedure.

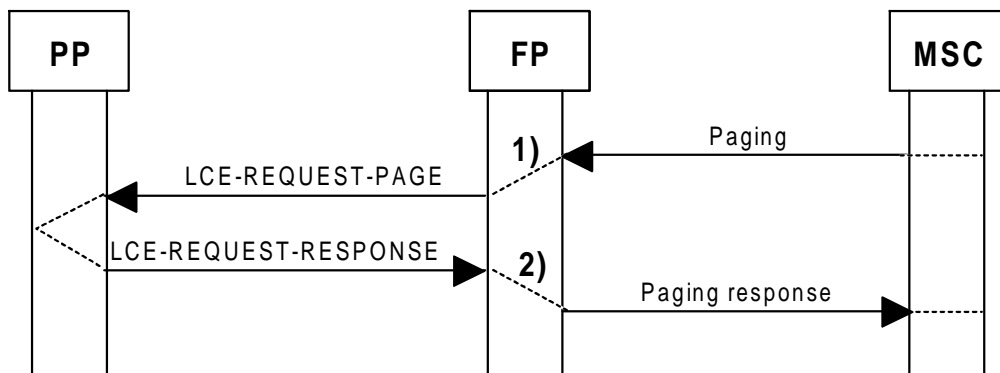

Figure 31: Paging related procedure

The received <<MOBILE IDENTITY>> information element is passed on to the DECT FT LCE which if no suitable link exists sends a {LCE-REQUEST-PAGE} message to the PT.

The received <<Mobile identity>> shall be mapped to the DECT paging identities according to one of the options listed below:

- if the FP has previously assigned an individual assigned TPUI to the PP, the FP IWU shall associate the received IPUI to the assigned TPUI which is used to page the PP.
- 2) Upon receipt of the {LCE-PAGE-RESPONSE} from the PT the FP IWU sends a Paging response message to the MSC. The mapping of the DECT {LCE-PAGE-RESPONSE} message to the GSM Paging response message is shown in subclause 6.1.6.2.2 if the <<Mobile identity>> information element in the Paging message was the IMSI. If the received <<Mobile identity>> information element in the Paging message was the <<TMSI>> and the received <<NWK ASSIGNED IDENTITY>> information element in the DECT {LCE-PAGE-RESPONSE} message was valid (as defined in annex B) the FP shall map the DECT {LCE-PAGE-RESPONSE} message to the GSM Paging response message as shown in subclauses 6.1.6.2.2 and 6.1.7.2.2. The Paging response message shall contain the MS Classmark 2 information element previously stored by the FP IWU (see subclause 6.1.2.3, table 8);

if a suitable link exists the LLME shall inform the FP IWU back and the FP IWU shall send the Paging response message to the MSC using the same <<Mobile identity>> as was used in the Paging message.

- 3) If timer <LCE.03> expires in the FP, i.e; no {LCE-PAGE-RESPONSE} has been received from the PT, the FP IWU does not send any message to the MSC.

In overload situations the FP IWU may ignore a Paging message coming from the MSC.

#### 6.1.4 Other specific IWU procedures

##### 6.1.4.1 Equipment identity IWU procedures

The mapping of the DECT IPEI to the GSM International Mobile Equipment Identity (IMEI) in the FP is defined in ETS 300 466 [16]. The mapping of the DECT IPEI to the GSM IMEI and the mapping of DECT IPEI to the GSM IMEISV is described in annex C.

##### 6.1.4.2 Miscellaneous procedures

###### 6.1.4.2.1 Notification of progress and interworking

At any time during establishment or release of a call and during an active call, the GSM network may send a Progress message to the FP IWU. This is sent to indicate the progress of the call in the event of interworking or in connection with the provision of in-band information/patterns.

Upon receipt of Progress message from the MSC the FP IWU shall issue a MNCC\_INFO-req primitive with a <<progress indication>> information element. The mapping of the GSM Progress message to the DECT {CC-INFO} message is described in subclause 6.1.6.1.18. The FP IWU shall also send a {CC-NOTIFY} message with the <<TIMER RESTART>> information element to the PP as described in subclause 6.1.6.1.19. In addition, if the message was received during the establishment or release of a call the FP IWU shall stop all CC timers related to that call, see figure 32.

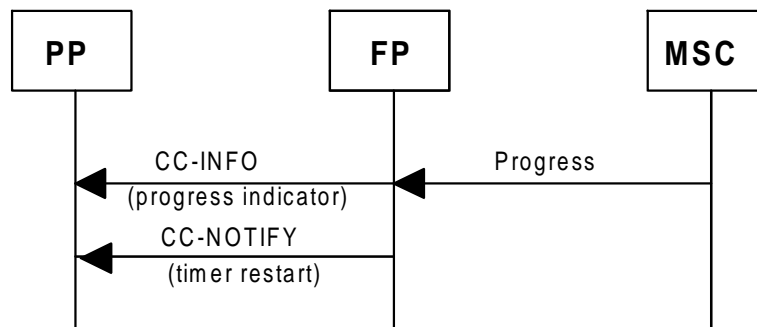

**Figure 32 Notification of progress or interworking by progress message**

During outgoing call establishment, notification of progress/interworking may also be indicated, by the GSM network, by including the <<progress indicator>> information element in a Call Proceeding, Alerting, or Connect message. Upon receipt of Call Proceeding, Alerting, or Connect message containing a GSM <<progress indicator>> information element, the FP IWU shall activate the DECT U-Plane if the progress description is according to the requirements defined in subclause 6.2.1. For detailed mapping see subclauses 6.1.6.1.9, 6.1.6.1.10, and 6.1.6.1.11.

During incoming call establishment, notification of interworking may also be indicated, by the GSM network, by including a <<progress indicator>> information element in the Setup message. Upon receipt of a GSM <<progress indicator>> information element in a Setup message from the MSC, the FP IWU shall activate the DECT U-Plane if the progress description is according to the requirements defined in subclause 6.2.1. For detailed mapping see subclauses 6.1.1.3 and 6.1.6.1.11.

During call release, notification of progress may also be indicated, by the GSM network, by including the <<progress indicator>> information element in a Disconnect message. Upon receipt of a GSM <<progress indicator>> information element in a Setup message from the MSC, the FP IWU shall activate the DECT U-Plane if the progress description is according to the requirements defined in subclause 6.2.1. For detailed mapping see subclauses 6.1.6.1.18 and 6.1.6.1.19.

For detailed description of notification of progress and interworking, see ETS 300 557 [21] (GSM 04.08).

### 6.1.4.2.2 User notification

At any time during an active call, the GSM network may send a Notify message to the FP/IWU. This is sent to indicate any call related event. For a detailed description of user notification, see ETS 300 590 [23] (GSM 04.08).

NOTE: Upon receipt of a Notify message from the MSC, the notification indication included may be mapped by the FP/IWU into an appropriate display information to the PP, using the {CC-INFO} message and/or a signalling tone over the downlink of the voice channel. The mapping of Notify to {CC-INFO} message is shown in subclause 6.1.6.1.30.

### 6.1.4.3 Handling of Dual Tone Multi-Frequency (DTMF)

A user may cause a DTMF signal to be generated e.g. by depression of a key at the PP. As shown in figure 33, the PP then sends a {CC-INFO} to the FP/IWU containing the DECT control character 16 Hex (Go to DTMF dialling; infinite tone length) followed by the selected digit (0...9, A-D, \*, #). On receipt of the {CC-INFO} the FP/IWU generates the appropriate Start DTMF message, containing the value of the digit to be transmitted ETS 300 557 [21] (GSM 04.08). The mapping of {CC-INFO} to Start DTMF is shown in subclause 6.1.6.2.18.

The MSC returns a Start DTMF ack message to the FP/IWU. This acknowledgement may optionally be mapped into an appropriate display information to the PP (by {CC-INFO}) and/or start a signalling tone on the downlink of the voice channel. The mapping of Start DTMF ack to {CC-INFO} is shown in subclause 6.1.6.1.22.

If the network cannot accept the Start DTMF message, a Start DTMF reject message will be sent to the FP/IWU (figure 34). The rejection again can optionally be mapped into an appropriate display information to the PP (by {CC-INFO}) and/or a signalling tone over the downlink of the voice channel. The mapping of Start DTMF reject to {CC-INFO} is shown in subclause 6.1.6.1.23.

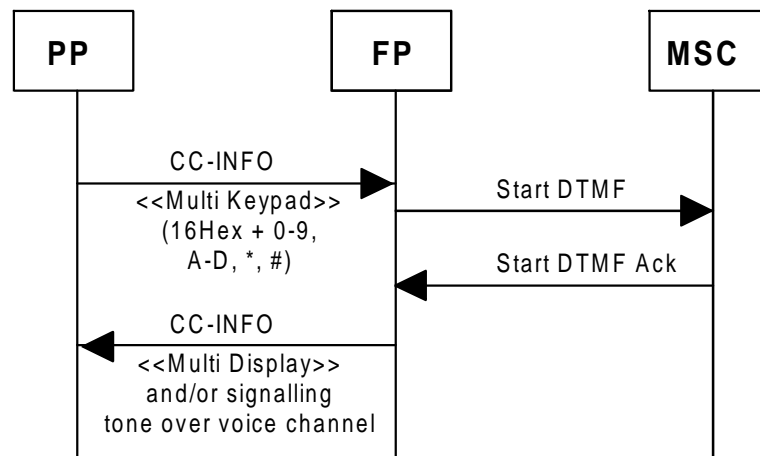
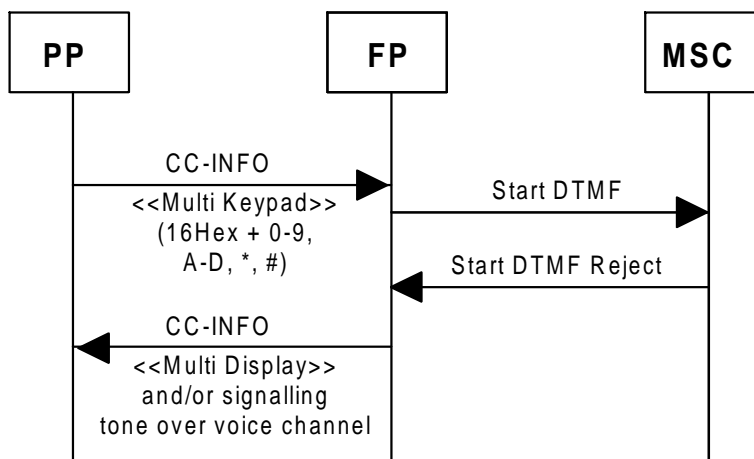

Figure 33: Acceptance of DTMF start message



**Figure 34: Rejection of DTMF start message**

When the user indicates that the DTMF sending should cease, e.g. by releasing the key, the PP emits another {CC-INFO} message containing the 00Hex control character (sending any DECT character, for example the next digit, also terminates the DTMF tone). On receipt the FP/IWU generates a Stop DTMF message acknowledged by a Stop DTMF ack message by the MSC (figure 35).

The acknowledgement message may be used by the FP/IWU to send a display message to the PP via {CC-INFO} and/or stop the signalling tone over the downlink of the voice channel. The mapping of {CC-INFO} to Stop DTMF is shown in subclause 6.1.6.2.19. The mapping of Stop DTMF ack to {CC-INFO} is shown in subclause 6.1.6.1.24.

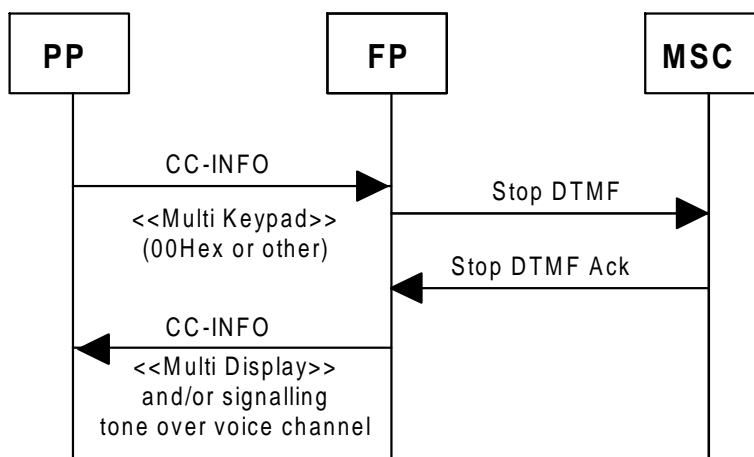

**Figure 35: Message flow to stop DTMF signal**

The minimum length of tone generated by the MSC should be according to ETR 206 [26]. There is no defined maximum length of the tone, which will normally cease when a Stop DTMF message is received by the MSC. However, the operator may choose to put a predefined limit on the duration of tones sent.

In case of sending a sequence of DTMF signals to the GSM network, each of the signals will be transmitted using the above described message flows. The minimum period of time between two subsequent tones should be according to ETR 206 [26].

The FP/IWU shall ensure that messages are not sent towards the network faster than the minimum times mentioned above will allow. The appropriate sequencing of DTMF control messages is achieved by using two timers which cannot expire before the minimum intervals.

## **6.1.5 Exception handling**

### **6.1.5.1 Error handling**

The FP shall handle the received DECT messages in error situations as defined in clause 17 of ETS 300 175-5 [5] "Handling of error and exception conditions" as a local matter and shall not perform any inter working mapping functions in this case.

The FP IWU shall check the validity of received messages from the MSC relating to protocol discriminator, message length, transaction identifier, message type, information elements and in error case act as defined in clause 8 of ETS 300 557 [21] (GSM 04.08) "Handling of unknown, unforeseen, and erroneous protocol data" for the MS, e.g. ignore the message or the faulty information element, return a MM-STATUS or STATUS message.

Clause 8 of ETS 300 557 [21] (GSM 04.08) applies in all cases except that the FP IWU shall never send a RR STATUS to the MSC.

The FP shall check the validity of the received messages from the MSC in terms of mapped information which are in the scope of this ETS relating to protocol discriminator errors, wrong message length and act as defined in clause 8 of ETS 300 557 [21] (GSM 04.08) for the MS.

### **6.1.5.2 Timers**

#### **6.1.5.2.1 Call handling IWU procedures**

The CC timer handling is detailed in subclause 6.1.1 (mainly the actions taken towards the MSC are detailed in this subclause) and in ETS 300 175-5 [5].

#### **6.1.5.2.2 Other IWU procedures and paging procedures**

The timer handling is detailed in subclauses 6.1.2 and 6.1.3 (mainly the actions taken towards the MSC are detailed in these subclauses) and in ETS 300 175-5 [5].

When timeout occurs in the FP, while waiting for a message from the PT, no message is returned to the MSC. The time supervision in the MSC applies.

The FP follows the retransmission scheme of the GSM PLMN, i.e. the FP retransmits a message only if it is retransmitted by the MSC. Neither PT nor FT shall restart any timer as a part of one and the same procedure.

6.1.6 Message mappings

6.1.6.1 GSM to DECT

Table 11: List of mapped messages

Item No	GSM Message	Status in GSM	DECT Message	Status in GAP	Ref.	Map status
1	AUTHENTICATION REQUEST	M	{AUTHENTICATION-REQUEST}	M	6.1.6.1.1	M
2	AUTHENTICATION REJECT	M	{MM-INFO-SUGGEST}	M	6.1.6.1.2	M
3	IDENTITY REQUEST	M	{IDENTITY-REQUEST}	O	6.1.6.1.3	M
4	TMSI REALLOCATION COMMAND	M	{TEMPORARY-IDENTITY-ASSIGN}	I	6.1.6.1.4	M
5	CIPHER MODE COMMAND	M	{CIPHER-REQUEST}	O/M	6.1.6.1.5	M
6	LOCATION UPDATING ACCEPT	M	{LOCATE-ACCEPT}	O/M	6.1.6.1.6	M
7	LOCATION UPDATING REJECT	M	{LOCATE-REJECT}	O/M	6.1.6.1.7	M
8	CM SERVICE REJECT	M	{CC-RELEASE-COM}	M	6.1.6.1.15	M
9	ABORT	M	{CC-RELEASE-COM}	M	6.1.6.1.16	M
10	CM SERVICE ACCEPT	M	{CC-SETUP-ACK}	M	6.1.6.1.25	M
11	ALERTING	M	{CC-ALERTING}	O	6.1.6.1.8	M
12	CALL PROC	M	{CC-CALL-PROC}	O	6.1.6.1.9	M
13	CONNECT	M	{CC-CONNECT}	M	6.1.6.1.10	M
14	DISCONNECT	M	{CC-RELEASE}	M	6.1.6.1.12	M
15	RELEASE	M	{CC-RELEASE-COM}	M	6.1.6.1.13	M
16	RELEASE-COMPLETE	M	{CC-RELEASE-COM}	M	6.1.6.1.14	M
17	SETUP	M	{CC-SETUP}	M	6.1.6.1.11	M
18	CONNECT-ACK	M	{CC-CONNECT-ACK}	M	6.1.6.1.17	M
19	PROGRESS	M	{CC-INFO}	M	6.1.6.1.18	M
20	PROGRESS	M	{CC-NOTIFY}	M	6.1.6.1.19	M
21	DISCONNECT	M	{CC-INFO}	M	6.1.6.1.20	M
22	RELEASE	M	{CC-RELEASE}	M	6.1.6.1.21	M
23	START-DTMF-ACK	M	{CC-INFO}	M	6.1.6.1.22	O
23	START-DTMF-REJECT	M	{CC-INFO}	M	6.1.6.1.23	O
24	STOP-DTMF-ACK	M	{CC-INFO}	M	6.1.6.1.24	O
25	STOP-DTMF-ACK	M	{CC-SETUP-ACK}	M	6.1.6.1.25	M
26	HANDOVER COMMAND	M	{MM-INFO-ACCEPT}	O	6.1.6.1.26	M
27	CLEAR COMMAND	M	{CC-RELEASE}	M	6.1.6.1.27	M
28	HANDOVER REQUIRED REJECT	M	{MM-INFO-REJECT}	O	6.1.6.1.28	M
29	HANDOVER COMMAND	M	{MM-INFO-SUGGEST}	M	6.1.6.1.29	M
30	NOTIFY	M	{CC-INFO}	M	6.1.6.1.30	M



6.1.6.1.1 AUTHENTICATION REQUEST-**{AUTHENTICATION-REQUEST}**

Table 12

Item No	Message coding GSM	Message coding DECT	Ref	Map. status	NOTE
	AUTHENTICATION- REQUEST	{AUTHENTICATION- REQUEST}			
1	Protocol discriminator	Protocol discriminator	6.1.8.1.1	M	
2	Skip indicator	Transaction identifier	6.1.8.1.24	M	
3	Message type	Message type	6.1.8.1.3	M	
4	Cipher key sequence number	Auth type	6.1.7.1.3	M	
5	Authentication parameter RAND	RAND	6.1.7.1.2	M	

6.1.6.1.2 AUTHENTICATION REJECT- **{MM-INFO-SUGGEST}**

Table 13

Item No	Message coding GSM	Message coding DECT	Ref	Map. status	NOTE
	AUTHENTICATION- REJECT	{MM-INFO-SUGGEST}			
1	Protocol discriminator	Protocol discriminator	6.1.8.1.1	M	
2	Skip indicator	Transaction identifier	6.1.8.1.24	M	
3	Message type	Message type	6.1.8.1.3	M	

6.1.6.1.3 IDENTITY-REQUEST - **{IDENTITY-REQUEST}**

Table 14

Item No	Message coding GSM	Message coding DECT	Ref	Map. status	NOTE
	IDENTITY-REQUEST	{IDENTITY-REQUEST}			
1	Protocol discriminator	Protocol discriminator	6.1.8.1.1	M	
2	Skip indicator	Transaction identifier	6.1.8.1.24	M	
3	Message type	Message type	6.1.8.1.3	M	
4	Identity type	Identity type	6.1.7.1.5	M	

6.1.6.1.4 TMSI REALLOCATION COMMAND - {TEMPORARY-IDENTITY-ASSIGN}

Table 15

Item No	Message coding GSM	Message coding DECT	Ref	Map. status	NOTE
	TMSI REALLOCATION COMMAND	{TEMPORARY-IDENTITY- ASSIGN}			
1	Protocol discriminator	Protocol discriminator	6.1.8.1.1	M	
2	Skip indicator	Transaction identifier	6.1.8.1.24	M	
3	Message type	Message type	6.1.8.1.3	M	
4	Location area identification	Location area	6.1.7.1.4	M	
5	Mobile identity	NWK assigned identity	6.1.7.1.1	M	
6	-	Duration		note	Lock limit = "111"B; Time limits="0100"B, 1 unit = 6 minutes = 2250 multiframes
NOTE: The <<DURATION>> information element shall be present if periodic location registration is initiated from the PP side.					

6.1.6.1.5 CIPHERING MODE COMMAND - {CIPHER-REQUEST}

Table 16

Item No	Message coding GSM	Message coding DECT	Ref	Map. status	NOTE
	CIPHERING MODE COMMAND	{CIPHER-REQUEST}			
1	-	Protocol discriminator	6.1.8.1.1	-	
2	-	Transaction identifier	6.1.8.1.24	-	
3	Message type	Message type	6.1.8.1.3	M	
4	Encryption information	Cipher-info	6.1.8.1.8	M	For the precise construction see subclause 6.1.2.6.
5	Cipher response mode	-		-	The FP IWU shall remember this request (if present) and shall add the IMEI corresponding to the relevant PP to the Ciphering mode complete message.

6.1.6.1.6 LOCATION UPDATING ACCEPT - {LOCATE-ACCEPT}

Table 17

Item No	Message coding GSM	Message coding DECT	Ref	Map. status	NOTE
	LOCATION UPDATING ACCEPT	{LOCATE-ACCEPT}			
1	Protocol discriminator	Protocol discriminator	6.1.8.1.1	M	
2	Skip indicator	Transaction identifier	6.1.8.1.24	M	
3	Message type	Message type	6.1.8.1.3	M	
4	-	Portable identity		-	
5	Location area identification	Location area	6.1.7.1.4	M	
6	Mobile identity	NWK assigned identity	6.1.7.1.1	C1	
7	Follow on proceed	-		-	
8	-	Duration		note	Lock limit = "111"B; Time limits="0100"B, 1 unit = 6 minutes = 2250 multiframes
C1: IF GSM <<Mobile identity>> information element includes a GSM TMSI THEN M ELSE IF GSM <<Mobile identity>> information element includes IMSI THEN assign invalid TMSI value ELSE X (see subclauses 6.1.2.3, 2)					
NOTE: The <<DURATION>> information element shall be present if periodic location registration is initiated from the PP side.					

6.1.6.1.7 LOCATION UPDATING REJECT - {LOCATE-REJECT}

Table 18

Item No	Message coding GSM	Message coding DECT	Ref	Map. status	NOTE
	LOCATION UPDATING REJECTED	{LOCATE-REJECT}			
1	Protocol discriminator	Protocol discriminator	6.1.8.1.1	M	
2	Skip indicator	Transaction identifier	6.1.8.1.24	M	
3	Message type	Message type	6.1.8.1.3	M	
4	Reject cause	Reject reason	6.1.7.1.6	M	

6.1.6.1.8 ALERTING - {CC-ALERTING}

Table 19

Item No	Message coding GSM	Message coding DECT	Ref.	Map status	NOTE
	ALERTING	{CC-ALERTING}			
1	Protocol discriminator	protocol discriminator	6.1.8.1.1	M	
2	Transaction identifier	transaction identifier	6.1.8.1.2	M	
3	Message type	message type	6.1.8.1.3	M	
4	facility	facility		I	
5	progress indicator	progress indicator	6.1.7.1.8	M	
6	user-user	iwu to iwu	-	I	

6.1.6.1.9 CALL-PROC - {CC-CALL-PROC}

Table 20

Item No	Message coding GSM	Message coding DECT	Ref.	Map status	NOTE
	CALL-PROCEEDING	{CC-CALL-PROC}			
1	Protocol discriminator	protocol discriminator	6.1.8.1.1	M	
2	Transaction identifier	transaction identifier	6.1.8.1.2	M	
3	Message type	message type	6.1.8.1.3	M	
4	Repeat indicator	-		-	
5	Bearer capability 1	-		-	
6	Bearer capability 2	-		-	
7	Progress indicator	progress indicator	6.1.7.1.8	M	

6.1.6.1.10 CONNECT - {CC-CONNECT}

Table 21

Item No	Message coding GSM	Message coding DECT	Ref.	Map status	NOTE
	CONNECT	{CC-CONNECT}			
1	protocol discriminator	protocol discriminator	6.1.8.1.1	M	
2	transaction identifier	transaction identifier	6.1.8.1.2	M	
3	message type	message type	6.1.8.1.3	M	
5	facility	facility		I	
6	progress indicator	progress indicator	6.1.7.1.8	M	
10	user to user	iwu to iwu		I	

6.1.6.1.11 SETUP - {CC-SETUP}

Table 22

Item No	Message coding GSM	Message coding DECT	Ref.	Map status	NOTE
	SETUP	{CC-SETUP}			
1	Protocol discriminator	protocol discriminator	6.1.8.1.1	M	
2	Transaction identifier	transaction identifier	6.1.8.1.2	M	
3	Message type	message type	6.1.8.1.3	M	
4	Repeat indicator	-		X	
5	Bearer capability 1	basic service	6.1.7.1.7	M	
5a	Bearer capability 2	-		X	
6	Facility	facility		I	
8	Progress indicator	progress indicator	6.1.7.1.8	M	
9	Signal	signal	6.1.7.1.11	M	
10	calling party BCD number	calling party number		I	
11	calling party subaddress	iwu to iwu		I	
12	called party BCD number	called party number		I	
13	called party subaddress	called party subaddress		I	
14	repeat indicator	-		X	
15	low layer compatibility	iwu to iwu		I	
16	repeat indicator	-		X	
17	high layer compatibility	iwu to iwu		I	
18	user to user	iwu to iwu		I	

6.1.6.1.12 DISCONNECT - {CC-RELEASE}

Table 23

Item No	Message coding GSM	Message coding DECT	Ref.	Map status	NOTE
	DISCONNECT	{CC-RELEASE}			
1	Protocol discriminator	protocol discriminator	6.1.8.1.1	M	
2	Transaction identifier	transaction identifier	6.1.8.1.2	M	
3	Message type	message type	6.1.8.1.3	M	
4	Cause	release reason	6.1.7.1.9	M	
5	Facility	facility		I	
6	Progress indicator	-		X	
7	-	display		X	
8	-	feature indicate		X	
9	User-user	iwu to iwu		I	
10	-	iwu packet		X	

6.1.6.1.13 RELEASE - {CC-RELEASE-COM}

Table 24

Item No	Message coding GSM	Message coding DECT	Ref.	Map status	NOTE
	RELEASE	{CC-RELEASE-COM}			
1	Protocol discriminator	protocol discriminator	6.1.8.1.1	M	
2	Transaction identifier	transaction identifier	6.1.8.1.2	M	
3	Message type	message type	6.1.8.1.3	M	
4	Cause	release reason	6.1.7.1.9	O	
5	Second cause	-		X	
6	Facility	facility		I	
7	User-user	iwu to iwu		I	

6.1.6.1.14 RELEASE COMPLETE - CC-RELEASE-COM

Table 25

Item No	Message coding GSM	Message coding DECT	Ref.	Map status	NOTE
	RELEASE COMPLETE	{CC-RELEASE-COM}			
1	Protocol discriminator	protocol discriminator	6.1.8.1.1	M	
2	Transaction identifier	transaction identifier	6.1.8.1.2	M	
3	Message type	message type	6.1.8.1.3	M	
4	Cause	release reason	6.1.7.1.9	O	
5	Facility	facility		I	
7	User-user	iwu to iwu		I	

6.1.6.1.15 CM SERVICE REJECT - {CC-RELEASE-COM}

Table 26

Item No	Message coding GSM	Message coding DECT	Ref.	Map status	NOTE
	CM SERVICE REJECT	{CC-RELEASE-COM}			
1	Protocol discriminator	protocol discriminator	6.1.8.1.1	M	
2	Skip indicator	transaction identifier	6.1.8.1.24	M	
3	Message type	message type	6.1.8.1.3	M	
4	Reject cause	release reason	6.1.7.1.10	M	

6.1.6.1.16 ABORT - {CC-RELEASE-COM}

Table 27

Item No	Message coding GSM	Message coding DECT	Ref.	Map status	NOTE
	ABORT	{CC-RELEASE-COM}			
1	Protocol discriminator	protocol discriminator	6.1.8.1.1	M	
2	Skip indicator	transaction identifier	6.1.8.1.24	M	
3	Message type	message type	6.1.8.1.3	M	
4	Reject cause	release reason	6.1.7.1.10	M	

6.1.6.1.17 CONNECT-ACK to {CC-CONNECT-ACK}

Table 28

Item No	Message coding GSM	Message coding DECT	Ref	Map. status	NOTE
	CONNECT-ACK	{CC-CONNECT-ACK}			
1	Protocol discriminator	Protocol discriminator	6.1.8.1.1	M	
2	Skip indicator	Transaction identifier	6.1.8.1.24	M	
3	Message type	Message type	6.1.8.1.3	M	

6.1.6.1.18 PROGRESS - {CC-INFO}

Table 29

Item No	Message coding GSM	Message coding DECT	Ref.	Map status	NOTE
	PROGRESS	{CC-INFO}			
1	Protocol discriminator	Protocol discriminator	6.1.8.1.1	M	
2	Transaction identifier	Transaction identifier	6.1.8.1.2	M	
3	Message Type	Message Type	6.1.8.1.3	M	
4	Progress indicator	progress indicator	6.1.7.1.8	M	
5	User-user	iwu to iwu		I	

6.1.6.1.19 PROGRESS - {CC-NOTIFY}

Table 30

Item No	Message coding GSM	Message coding DECT	Ref.	Map status	NOTE
	PROGRESS	{CC-NOTIFY}			
1	Protocol discriminator	Protocol discriminator	6.1.8.1.1	M	
2	Transaction identifier	Transaction identifier	6.1.8.1.2	M	
3	Message Type	Message Type	6.1.8.1.3	M	
4	Progress indicator	-		X	
5	User-user	-		X	
6	-	Timer Restart	-	X	note
NOTE: Timer Restart information element is generated locally in the FP IWU and shall indicate 'stop timer'.					

6.1.6.1.20 DISCONNECT - {CC-INFO}

Table 31

Item No	Message coding GSM	Message coding DECT	Ref.	Map status	NOTE
	DISCONNECT	{CC-INFO}			
1	Protocol discriminator	protocol discriminator	6.1.8.1.1	M	
2	Transaction identifier	transaction identifier	6.1.8.1.2	M	
3	Message type	message type	6.1.8.1.3	M	
4	Cause	-		X	
5	Facility	facility		I	
6	Progress indicator	progress indicator	6.1.7.1.8	M	
7	-	display		X	
8	-	feature indicate		X	
9	User-user	iwu to iwu		I	
10	-	iwu packet		X	

6.1.6.1.21 RELEASE - {CC-RELEASE}

Table 32

Item No	Message coding GSM	Message coding DECT	Ref.	Map status	NOTE
	RELEASE	{CC-RELEASE}			
1	Protocol discriminator	protocol discriminator	6.1.8.1.1	M	
2	Transaction identifier	transaction identifier	6.1.8.1.2	M	
3	Message type	message type	6.1.8.1.3	M	
4	Cause	release reason	6.1.7.1.9	O	
5	Second cause	-		X	
6	Facility	facility		I	
7	User-user	iwu to iwu		I	

6.1.6.1.22 START-DTMF-ACK - {CC-INFO}

Table 33

Item No	Message coding GSM	Message coding DECT	Ref.	Map status	NOTE
	START-DTMF-ACK	{CC-INFO}			
1	Protocol discriminator	Protocol discriminator	6.1.8.1.1	M	
2	Transaction identifier	Transaction identifier	6.1.8.1.2	M	
3	Start DTMF acknowledge Message type	Message type	6.1.8.1.3	M	
4	Keypad facility	Multi Display	6.1.7.1.12	C1	NOTE 1
NOTE 1: Keypad facility is translated into audio and/or display by the IWU					
C1: If Multi Display then M else I					

6.1.6.1.23 START-DTMF-REJECT - {CC-INFO}

Table 34

Item No	Message coding GSM	Message coding DECT	Ref.	Map status	NOTE
	START-DTMF-REJECT	{CC-INFO}			
1	Protocol discriminator	Protocol discriminator	6.1.8.1.1	M	
2	Transaction identifier	Transaction identifier	6.1.8.1.2	M	
3	Start DTMF reject message type	Message type	6.1.8.1.3	M	
4	Cause	Multi Display	6.1.7.1.13	C1	NOTE 1
NOTE 1: Cause is translated into audio and/or display by the IWU					
C1: If Multi Display then M else I					

6.1.6.1.24 STOP-DTMF-ACK - {CC-INFO}

Table 35

Item No	Message coding GSM	Message coding DECT	Ref.	Map status	NOTE
	STOP-DTMF-ACK	{CC-INFO}			
1	Protocol discriminator	Protocol discriminator	6.1.8.1.1	M	
2	Transaction identifier	Transaction identifier	6.1.8.1.2	M	
3	Stop DTMF message type	Message type	6.1.8.1.3	M	

6.1.6.1.25 CM SERVICE ACCEPT - {CC-SETUP-ACK}

Table 36

Item No	Message coding GSM	Message coding DECT	Ref.	Map status	NOTE
	CM SERVICE ACCEPT	{CC-SETUP-ACK}			
1	Protocol discriminator	protocol discriminator	6.1.8.1.1	M	
2	Skip indicator	transaction identifier	6.1.8.1.24	M	
3	CM Service Accept message type	message type	6.1.8.1.3	M	
4	-	delimiter request	-	X	NOTE
NOTE: Delimiter request information element is generated locally in the FP IWU.					



6.1.6.1.26 Handover Command - {MM-INFO-ACCEPT}

Table 37

Item No	Message coding GSM	Message coding DECT	Ref.	Map status	NOTE
	HANDOVER COMMAND	{MM-INFO-ACCEPT}			
1	-	Protocol discriminator		-	
2	-	Transaction identifier		-	
3	Message type	Message type	6.1.8.1.3	M	
4	Layer 3 information	Fixed Identity	6.1.7.1.14	M	
5	Layer 3 information	Network Parameter	6.1.7.1.15	M	

6.1.6.1.27 Clear Command - {CC-RELEASE}

Table 38

Item No	Message coding GSM	Message coding DECT	Ref.	Map status	NOTE
	CLEAR COMMAND	{CC-RELEASE}			
1	-	Protocol discriminator		-	
2	-	Transaction identifier		-	
3	Message type	Message type	6.1.8.1.3	M	
4	Layer 3 header information	-		-	
5	Cause	Release reason		M	NOTE
NOTE	GSM coding of 'handover successful', as defined in ETS 300 590 [0] (GSM 08.08) shall be mapped to DECT 'External handover release' as defined in ETS 300 175-5 [5]. Other GSM cause values shall be mapped to DECT 'unknown' as defined in ETS 300 175-5 [5].				

6.1.6.1.28 Handover Required Reject - {MM-INFO-REJECT}

Table 39

Item No	Message coding GSM	Message coding DECT	Ref.	Map status	NOTE
	HANDOVER REQUIRED REJECT	{MM-INFO-REJECT}			
1	-	Protocol discriminator		-	
2	-	Transaction identifier		-	
3	Message type	Message type	6.1.8.1.3	M	
4	Cause	Reject reason		I	

6.1.6.1.29 Handover Command - {MM-INFO-SUGGEST}

Table 40

Item No	Message coding GSM	Message coding DECT	Ref.	Map status	NOTE
	HANDOVER COMMAND	{MM-INFO-SUGGEST}			
1	-	Protocol discriminator		-	
2	-	Transaction identifier		-	
3	Message type	Message type	6.1.8.1.3	M	
4	-	Info Type		-	Should indicate 'external handover candidate'
5	Layer 3 information	Fixed Identity	6.1.7.1.14	M	
6	Layer 3 information	Network Parameter	6.1.7.1.15	M	

6.1.6.1.30 NOTIFY - {CC-INFO}

Table 40a

Item No	Message coding GSM	Message coding DECT	Ref.	Map status	NOTE
	NOTIFY	{CC-INFO}			
1	Protocol discriminator	Protocol discriminator	6.1.8.1.1	M	
2	Transaction identifier	Transaction identifier	6.1.8.1.2	M	
3	Notify message type	Message type	6.1.8.1.3	M	
4	Notification indicator	Multi-display	6.1.7.1.16	M	

6.1.6.2 DECT to GSM

Table 41: List of mapped messages

Item No	DECT Message	Status in GAP	GSM Message	Status in GSM	Ref.	Map status
1	{LOCATE-REQUEST}	O/M	LOCATION - UPDATING-REQUEST	M	6.1.6.2.1	M
2	{LCE-PAGE-RESPONSE}	M	PAGING-RESPONSE	M	6.1.6.2.2	M
3	{AUTHENTICATION-REPLY}	O/M	AUTHENTICATION RESPONSE	M	6.1.6.2.3	M
4	{DETACH}	I	IMSI DETACH INDICATION	M	6.1.6.2.4	M
5	{TEMPORARY-IDENTITY-ASSIGN-ACK}	O/M	TMSI REALLOCATION COMPLETE	M	6.1.6.2.5	M
6	{IDENTITY-REPLY}	O	IDENTITY RESPONSE	M	6.1.6.2.7	M
7	{CC-ALERTING}	M	ALERTING	M	6.1.6.2.8	M
8	{CC-CONNECT}	M	CONNECT	M	6.1.6.2.9	M
9	{CC-INFO} (F-02)	M	SETUP	M	6.1.6.2.10	M
10	{CC-RELEASE}	M	DISCONNECT	M	6.1.6.2.11	M
11	{CC-RELEASE}	M	RELEASE	M	6.1.6.2.12	M
12	{CC-RELEASE-COM}	M	RELEASE	M	6.1.6.2.13	M
13	{CC-RELEASE-COM}	M	RELEASE-COMPLETE	M	6.1.6.2.14	M
14	{CC-SETUP}	M	SETUP	M	6.1.6.2.15	M
15	{CC-SETUP}	I	EMERGENCY SETUP	M	6.1.6.2.16	M
16	{CC-RELEASE}	M	CM SERVICE ABORT	M	6.1.6.2.17	M
17	{CC-SETUP}	M	CM SERVICE REQUEST	M	6.1.6.2.6	M
18	{CC-INFO}	M	START-DTMF	M	6.1.6.2.18	M
19	{CC-INFO}	M	STOP-DTMF	M	6.1.6.2.19	M
20	{MM-INFO-REQUEST}		HANDOVER REQUIRED	M	6.1.6.2.20	M
21	{CC-SETUP}	M	HANDOVER DETECT	M	6.1.6.2.21	M
22	{CC-CONNECT-ACK}	M	HANDOVER COMPLETE	M	6.1.6.2.22	M
23	{MM-INFO-REQUEST}	O	HANDOVER FAILURE	M	6.1.6.2.23	M

6.1.6.2.1 {LOCATE-REQUEST} - LOCATION-UPDATING-REQUEST

Table 42

Item No	Message coding DECT	Message coding GSM	Ref	Map. status	NOTE
	{LOCATE-REQUEST}	LOCATION-UPDATING-REQUEST			
1	Protocol discriminator	Protocol discriminator	6.1.8.2.1	M	
2	Transaction identifier	Skip Indicator	6.1.8.2.21	M	
3	Message type	Message type	6.1.8.2.3	M	
4	Portable identity	Mobile identity	6.1.7.2.1	C1	
5	Location area	Location area identification	6.1.7.2.3	M	
6	Network assigned identity	Mobile identity	6.1.7.2.2	C2	
7	Cipher info	Cipher key sequence number	6.1.7.2.4	M	
8	-	Location updating type	-	X	NOTE 1
9		Mobile station classmark 1	-	X	NOTE 2
10	Fixed identity			X	
11	Terminal capability	-		X	NOTE 3
C1:	IF <<NWK ASSIGNED IDENTITY >> information element or the <Extended location information>> field in the <<LOCATION AREA>> information element is not valid (see annex B) THEN M ELSE X.				
C2:	IF <<NWK ASSIGNED IDENTITY >> information element and <Extended location information>> field in the <<LOCATION AREA>> information element are valid (see annex B) THEN M ELSE X.				
NOTE 1:	This information element does not exist at the DECT air interface. The value of this information element depends on previous transactions as described in subclause 6.1.2.3.				
NOTE 2:	Mobile station classmark 1 information element is generated locally at the FP IWU (see table 7 in subclause 6.1.2.3)				
NOTE 3:	The <Profile indicator_2> field is stored in the FP IWU for use in GSM Paging Response (see subclause 6.1.6.2.2)				

6.1.6.2.2 {LCE-PAGE-RESPONSE} - PAGING RESPONSE

Table 43

Item No	Message coding DECT	Message coding GSM	Ref	Map. status	NOTE
	{LCE-PAGE-RESPONSE}	PAGING RESPONSE			
1	Protocol discriminator	Protocol discriminator	6.1.8.2.1	M	
2	Transaction identifier	Skip Indicator	6.1.8.2.21	M	
3	Message type	Message type	6.1.8.2.3	M	
4	Portable identity	Mobile identity	6.1.7.2.1	C1	
5	Fixed identity	-		X	
6	NWK assigned identity	Mobile identity	6.1.7.2.2.	C2	
7	Cipher info	Cipher key sequence number	6.1.7.2.4	M	
8	-	Mobile station classmark 2	-	X	NOTE
<p>C1: IF the received &lt;&lt;Mobile identity&gt;&gt; information element in the Paging message was the &lt;&lt;IMSI&gt;&gt; or the received &lt;&lt;NWK ASSIGNED IDENTITY&gt;&gt; information element is not valid THEN M ELSE X.</p> <p>C2: IF the received &lt;&lt;Mobile identity&gt;&gt; information element in the Paging message was the &lt;&lt;TMSI&gt;&gt; and the received &lt;&lt;NWK ASSIGNED IDENTITY&gt;&gt; information element is valid THEN M ELSE X.</p> <p>NOTE: Mobile station classmark 2 information element is generated locally at the FP IWU (see table 8 in subclause 6.1.2.3)</p>					

6.1.6.2.3 {AUTHENTICATION-REPLY} - AUTHENTICATION RESPONSE

Table 44

Item No	Message coding DECT	Message coding GSM	Ref	Map. status	NOTE
	{AUTHENTICATION-REPLY}	AUTHENTICATION RESPONSE			
1	Protocol discriminator	Protocol discriminator	6.1.8.2.1	M	
2	Transaction identifier	Skip Indicator	6.1.8.2.21	M	
3	Message type	Message type	6.1.8.2.3	M	
4	RES	Auth. parameter SRES	6.1.7.2.5	M	

6.1.6.2.4 {DETACH} - IMSI DETACH INDICATION

Table 45

Item No	Message coding DECT	Message coding GSM	Ref	Map. status	NOTE
	{DETACH}	IMSI-DETACH-INDICATION			
1	Protocol discriminator	Protocol discriminator	6.1.8.2.1	M	
2	Transaction identifier	Skip Indicator	6.1.8.2.21	M	
3	Message type	Message type	6.1.8.2.3	M	
4	Portable identity	Mobile identity	6.1.7.2.6	C1	NOTE 1
5	Network assigned identity	Mobile identity	6.1.7.2.2	C2	
6	-	Mobile station classmark 1	-	X	NOTE 2
C1: IF <<NWK ASSIGNED IDENTITY>> information element valid (see annex B) THEN M ELSE X.					
C2: IF <<NWK ASSIGNED IDENTITY>> information element is not valid (see annex B) THEN M ELSE X.					
NOTE 1: If Portable identity is TPUI, then FP will derive the IMSI from the IPUI R					
NOTE 2: Mobile station classmark 1 information element is generated locally at the FP IWU, (see table 7 in subclause 6.1.2.3).					

6.1.6.2.5 {TEMPORARY-IDENTITY-ASSIGN-ACK} - TMSI REALLOCATION COMPLETE

Table 46

Item No	Message coding DECT	Message coding GSM	Ref	Map. status	NOTE
	{TEMPORARY-IDENTITY-ASSIGN-ACK}	TMSI REALLOCATION COMPLETE			
1	Protocol discriminator	Protocol discriminator	6.1.8.2.1	M	
2	Transaction identifier	Skip indicator	6.1.8.2.21	M	
3	Message type	Message type	6.1.8.2.3	M	

6.1.6.2.6 {CC-SETUP} - CM SERVICE REQUEST

Table 47

Item No	Message coding DECT	Message coding GSM	Ref	Map. status	NOTE
	{CC-SETUP}	CM SERVICE REQUEST			
1	Protocol discriminator	Protocol discriminator	6.1.8.2.1	M	
2	Transaction identifier	Skip Indicator	6.1.8.2.21	M	
3	Message type	Message type	6.1.8.2.3	M	
4	Portable identity	Mobile identity	6.1.7.2.6	C1	
5	Basic service	CM service type	6.1.7.2.7	M	NOTE 1
6	Basic service	Mobile station classmark 2	-	M	NOTE 2
7	Cipher info	Ciphering key sequence number	6.1.7.2.4	M	
8	Network assigned identity	Mobile identity	6.1.7.2.2	C2	
NOTE 1: mapping of call class field					
NOTE 2: Mobile station classmark 2 information element is generated locally at the FP IWU (see table 8 in subclause 6.1.2.3)					
C1: IF <<NWK ASSIGNED IDENTITY>> information element is not valid (see Annex B) THEN M ELSE X.					
C2: IF <<NWK ASSIGNED IDENTITY>> information element is valid (see Annex B) THEN M ELSE X.					

6.1.6.2.7 {IDENTITY-REPLY} - IDENTITY RESPONSE

Table 48

Item No	Message coding DECT	Message coding GSM	Ref	Map. status	NOTE
	{IDENTITY-REPLY}	IDENTITY RESPONSE			
1	Protocol discriminator	Protocol discriminator	6.1.8.2.1	M	
2	Transaction identifier	Skip Indicator	6.1.8.2.21	M	
3	Message type	Message type	6.1.8.2.3	M	
4	Portable identity	Mobile identity	6.1.7.2.6	C2	
5	NWK assigned identity	Mobile identity	6.1.7.2.2	C1	
C1:	IF <<NWK ASSIGNED IDENTITY>> information element and <Extended location information>> field in the <<Location area>> information element are valid (see annex B) THEN M ELSE X.				
C2:	IF <<NWK ASSIGNED IDENTITY>> information element or the <Extended location information>> field in the <<LOCATION AREA>> information element is not valid (see annex B) THEN M ELSE X.				

6.1.6.2.8 {CC-ALERTING} - ALERTING

Table 49

Item No	Message coding DECT	Message coding GSM	Ref.	Map status	NOTE
	{CC-ALERTING}	ALERTING			
1	protocol discriminator	protocol discriminator	6.1.8.2.1	M	
2	transaction identifier	transaction identifier	6.1.8.2.2	M	
3	message type	message type	6.1.8.2.3	M	
4	call attributes	-		X	
5	connection identity	-		X	
6	progress indicator	-		X	
7	display	-		X	
8	signal	-		X	
9	feature indicate	-		X	
10	terminal capability	-		X	
11	transit delay	-		X	
12	window size	-		X	
13	iwu to iwu	user- user		I	
14	iwu packet	-		X	
15	-	SS version indicator		I	Relate to facility

6.1.6.2.9 {CC-CONNECT} - CONNECT

Table 50

Item No	Message coding DECT	Message coding GSM	Ref.	Map status	NOTE
	{CC-CONNECT}	CONNECT			
1	protocol discriminator	protocol discriminator	6.1.8.2.1	M	
2	transaction identifier	transaction identifier	6.1.8.2.2	M	
3	message type	message type	6.1.8.2.3	M	
4	call attributes	-		X	
5	connection identity	-		X	
6	progress indicator	-		X	
7	display	-		X	
8	signal	-		X	
9	feature indicate	-		X	
10	terminal capability	-		X	
11	transit delay	-		X	
12	window size	-		X	
13	iwu to iwu	user- user		I	
14	iwu packet	-		I	
15	-	SS version indicator		I	Relate to facility

6.1.6.2.10 {CC-INFO} (F-02) - SETUP

Table 51

Item No	Message coding DECT	Message coding GSM	Ref.	Map status	NOTE
	{CC-INFO} (F-02)	SETUP			
1	protocol discriminator	protocol discriminator	6.1.8.2.1	M	
2	transaction identifier	transaction identifier	6.1.8.2.2	M	
3	message type	message type	6.1.8.2.3	M	
4	location area	-		I	
5	-	Bearer capability 1		X	
6	NWK assigned identity	-		I	
7	progress indicator	-		X	
8	display	-		X	
9	multi keypad	called party number	6.1.7.2.10	C1	
10	signal	-		X	
11	feature activate	-		I	
12	feature indicate	-		X	
13	network parameter	-		I	
14	called party number	-		X	
15	called party subaddress	-		I	
16	sending complete	-		I	
17	test hook control	-		X	
18	iwu to iwu	-		I	
19	iwu packet	-		I	
20	-	CC capabilities		X	
C1:	IF keys are dialling information THEN M ELSE X				



6.1.6.2.11 {CC-RELEASE} - DISCONNECT

Table 52

Item No	Message coding DECT	Message coding GSM	Ref.	Map status	NOTE
	{CC-RELEASE}	DISCONNECT			
1	protocol discriminator	protocol discriminator	6.1.8.2.1	M	
2	transaction identifier	transaction identifier	6.1.8.2.2	M	
3	message type	message type	6.1.8.2.3	M	
4	release reason	cause	6.1.7.2.12	O	
5	display	-		X	
6	feature indicate	-		X	
7	iwu to iwu	user- user		I	
8	iwu packet	-		I	

6.1.6.2.12 {CC-RELEASE} - RELEASE

Table 53

Item No	Message coding DECT	Message coding GSM	Ref.	Map status	NOTE
	{CC-RELEASE}	RELEASE			
1	protocol discriminator	protocol discriminator	6.1.8.2.1	M	
2	transaction identifier	transaction identifier	6.1.8.2.2	M	
3	message type	message type	6.1.8.2.3	M	
4	release reason	cause	6.1.7.2.14	O	
5	repeat indicator	-		X	
6	progress indicator	-		X	
7	iwu to iwu	user- user		I	
8	iwu packet	-		I	
9	escape to proprietary	-		X	

6.1.6.2.13 CC-RELEASE-COM - RELEASE

Table 54

Item No	Message coding DECT	Message coding GSM	Ref.	Map status	NOTE
	{CC-RELEASE-COM}	RELEASE			
1	protocol discriminator	protocol discriminator	6.1.8.2.1	M	
2	transaction identifier	transaction identifier	6.1.8.2.2	M	
3	message type	message type	6.1.8.2.3	M	
4	release reason	cause	6.1.7.2.12	O	
5	iwu attributes	-		X	
6	repeat indicator	-		X	
7	facility	-		X	
8	repeat indicator	-		X	
9	iwu to iwu	user- user		I	
10	iwu packet	-		I	
11	escape to proprietary	-		X	

## 6.1.6.2.14 {CC-RELEASE-COM} - RELEASE-COMLETE

Table 55

Item No	Message coding DECT	Message coding GSM	Ref.	Map status	NOTE
	{CC-RELEASE-COM}	RELEASE-COMLETE			
1	protocol discriminator	protocol discriminator	6.1.8.2.1	M	
2	transaction identifier	transaction identifier	6.1.8.2.2	M	
3	message type	message type	6.1.8.2.3	M	
4	release reason	cause	6.1.7.2.12	O	
5	identity type	-		X	
6	location area	-		X	
7	iwu attributes	-		X	
8	display	-		X	
9	feature indicate	-		X	
10	network parameter	-		X	
11	iwu to iwu	user to user		I	
12	iwu packet	-		I	

6.1.6.2.15 {CC-SETUP} - SETUP

Table 56

Item No	Message coding DECT	Message coding GSM	Ref.	Map status	NOTE
	{CC-SETUP}	SETUP			
1	protocol discriminator	protocol discriminator	6.1.8.2.1	M	
2	transaction identifier	transaction identifier	6.1.8.2.2	M	
3	message type	message type	6.1.8.2.3	M	
4	portable identity	-		I	
5	fixed identity	-		I	
6	Basic service	Bearer capabilities	6.1.7.2.8	M	
7	iwu attributes	-		I	
8	repeat indicator	-		I	
9	call attributes	-		I	
10	repeat indicator	-		I	
11	connection attributes	-		I	
12	cipher info	-		I	Used in CM service procedure
13	connection identity	-		X	
14	facility	-		I	
15	progress indicator	-		X	Not allowed in this direction in DECT
16	display	-		X	
17	multi keypad	-		I	
18	signal	-		X	
19	feature activate	-		I	
20	feature indicate	-		X	
21	network parameter	-		I	Used external H/O procedure
22	terminal capability	-		I	
23	end to end compatibility	-		I	
24	rate parameter	-		X	
25	transit delay	-		X	
26	window size	-		X	
27	calling party number	-		I	
28	called party number	called party number	6.1.7.2.9	M	
29	called party subaddress	-		I	
30	sending complete	-		X	
31	iwu to iwu	-		X	
32	iwu packet	-		X	
33	-	CC capabilities		X	

6.1.6.2.16 {CC-SETUP} - EMERGENCY-SETUP

Table 57

Item No	Message coding DECT	Message coding GSM	Ref.	Map status	NOTE
	{CC-SETUP}	EMERGENCY-SETUP			
1	protocol discriminator	protocol discriminator	6.1.8.1.1	M	
2	transaction identifier	transaction identifier	6.1.8.2.2	M	
3	message type	message type	6.1.8.1.3	M	
4	portable identity	-		I	
5	fixed identity	-		I	
6	basic service	bearer capabilities	6.1.7.2.8	O	
7	iwu attributes	-		I	
8	repeat indicator	-		X	
9	call attributes	-		X	
10	repeat indicator	-		X	
11	connection attributes	-		X	
12	cipher info	-		I	
13	connection identity	-		X	
14	facility	-		I	
15	progress indicator	-		X	
16	display	-		X	
17	multi keypad	-		I	
18	signal	-		X	
19	feature activate	-		I	
20	feature indicate	-		X	
21	network parameter	-		I	
22	terminal capability	-		X	
23	end to end compatibility	-		I	
24	rate parameter	-		X	
25	transit delay	-		X	
26	window size	-		X	
27	calling party number	-		I	
28	called party number	-		I	
29	called party subaddress	-		I	
30	sending complete	-		I	
31	iwu to iwu	-		I	
32	iwu packet	-		I	

6.1.6.2.17 {CC-RELEASE} - CM SERVICE ABORT

Table 58

Item No	Message coding DECT	Message coding GSM	Ref.	Map status	NOTE
	{CC-RELEASE}	CM SERVICE ABORT			
1	protocol discriminator	Protocol discriminator	6.1.8.2.1	M	
2	transaction identifier	Skip indicator	6.1.8.2.21	M	
3	message type	Message type	6.1.8.2.3	M	
4	release reason	-		X	
5	facility	-		X	
6	display	-		X	
7	feature indicate	-		X	
8	iwu to iwu	-		X	
9	iwu packet	-		X	

6.1.6.2.18 {CC-INFO} - START-DTMF

Table 59

Item No	Message coding DECT	Message coding GSM	Ref	Map. status	NOTE
	{CC-INFO}	START-DTMF			
1	Protocol discriminator	Protocol discriminator	6.1.8.1.1	M	
2	Transaction identifier	Transaction identifier	6.1.8.1.2	M	
3	Message type	Message type	6.1.8.1.3	M	
4	Multi Keypad	Keypad facility	6.1.7.2.11	M	

6.1.6.2.19 {CC-INFO} - STOP-DTMF

Table 60

Item No	Message coding DECT	Message coding GSM	Ref	Map. status	NOTE
	{CC-INFO}	STOP-DTMF			
1	Protocol discriminator	Protocol discriminator	6.1.8.1.1	M	
2	Transaction identifier	Skip Indicator	6.1.8.1.2	M	
3	Message type	Message type	6.1.8.1.3	M	

6.1.6.2.20 {MM-INFO-REQUEST} - Handover required

Table 61

Item No	Message coding DECT	Message coding GSM	Ref.	Map status	NOTE
	{MM-INFO-REQUEST}	HANDOVER REQUIRED			
1	Protocol discriminator	-		I	
2	Transaction identifier	-		I	
3	Message type	Message type	6.1.8.2.3	M	
4	Info type	-		I	NOTE 1
5	Portable identity	-		I	
6	Repeat indicator	-		I	NOTE 2
7	Fixed identity	Cell identifier list (preferred)		I	NOTE 2
8	Location area	-		I	
9	NWK assigned identity	-		I	
10	Network parameter	-		I	
11	IWU to IWU	-		I	
12	-	Cause	-	I	Generated by the IWU, should indicate "better cell"
13	-	Response request	-	I	May be generated by the IWU
14	-	Current channel	-	I	
15	-	Queuing indicator	-	I	
NOTE 1: The PP should indicate "handover reference". The IE is however not mapped by the FP.					
NOTE 2: Fixed identity may be repeated to indicate multiple target cells. Generation of cell identifier list is a local matter for the FP/IWU. This is based on configuration management data of possible external handover candidates.					

6.1.6.2.21 {CC-SETUP} - Handover detect

Table 62

Item No	Message coding DECT	Message coding GSM	Ref.	Map status	NOTE
	{CC-SETUP}	HANDOVER DETECT			
1	Protocol discriminator	-		I	
2	Transaction identifier	-		I	
3	Message type	Message type	6.1.8.2.3	M	
4	Portable identity	-		-	
5	Fixed identity	-		-	
6	Basic service	-		-	Should indicate "external handover call set-up"
7	Network parameter	-		-	Should indicate "Handover reference, GSM network"

6.1.6.2.22 {CC-CONNECT-ACK} - handover complete

Table 63

Item No	Message coding DECT	Message coding GSM	Ref.	Map status	NOTE
	{CC-CONNECT-ACK}	HANDOVER COMPLETE			
1	Protocol discriminator	-		I	
2	Transaction identifier	-		I	
3	Message type	Message type	6.1.8.2.3	M	
6	Repeat indicator	-		-	
7	IWU-TO-IWU	-		-	
8	IWU-PACKET	-		-	

6.1.6.2.23 {MM-INFO-REQUEST} - handover failure

Table 64

Item No	Message coding DECT	Message coding GSM	Ref.	Map status	NOTE
	{MM-INFO-REQUEST}	HANDOVER FAILURE			
1	Protocol discriminator	-		I	
2	Transaction identifier	-		I	
3	Message type	Message type	6.1.8.2.3	M	
4	Info type	Cause	6.1.7.2.13	M	NOTE 1
5	Portable identity	-		I	
6	Fixed identity	-		I	
7	Location area	-		I	
8	NWK assigned identity	-		I	
9	Network parameter	-		I	
10	IWU to IWU	-		I	
11	-	RR Cause	-	I	NOTE 2

NOTE 1: Info type shall indicate 'handover failure - reversion to old channel'.

NOTE 2: No Mapping, RR Cause shall indicate 'Abnormal release, channel unacceptable'.

6.1.7 Information element mappings

6.1.7.1 GSM to DECT

6.1.7.1.1 Mobile identity - NWK assigned identity

Table 65

Item No	Information element coding GSM	Information element coding DECT	Ref	Map status	NOTE
	Mobile identity	NWK assigned identity	.	M	
1	Mobile identity IEI	ID for NWK assigned identity	6.1.8.1.4	M	
2	Length of contents	Length of contents	6.1.8.1.5	M	
3	Odd/even indication = "0"	-		X	
4	Type of identity	Type	6.1.8.1.6	M	
5	-	Length of identity value = "32"		X	NOTE
6	Identity digits	Identity value	6.1.8.1.7	M	

NOTE: Given in binary (=4 octets).

6.1.7.1.2 Authentication parameter RAND - RAND

Table 66

Item No	Information element coding GSM	Information element coding DECT	Ref	Map status	NOTE
	Auth. parameter RAND	RAND	.	M	
1	RAND IEI	ID for RAND	6.1.8.1.4	M	
2	-	Length of contents			16, fixed length in GSM 128 bits
3	RAND value	RAND field	6.1.8.1.9	M	

6.1.7.1.3 Cipher key sequence number - auth type

Table 67

Item No	Information element coding GSM	Information element coding DECT	Ref	Map status	NOTE
	Cipher key sequence number	Auth type		M	
1	Cipher key sequence number IEI	ID for Auth type	6.1.8.1.4	M	
2	-	Length of contents		-	= 3
3	-	<Authentication algorithm identifier>		-	= 01000000B (GSM authentication algorithm)
4	-	<Authentication key type>		-	= 0001B (User authentication key)
5	-	<Authentication key number>		-	= 0000B (Key associated to the active IPUI)
6	-	<INC bit>		-	= 0B
7	-	<TXC>		-	= 0B (Do not include the derived cipher key in {AUTH-REPLY})
8	-	<UPC bit>		-	= 1B (Store cipher key)
9	Key sequence	Cipher key number	6.1.8.1.10	M	

6.1.7.1.4 Location area identification - location area

Table 68

Item No	Information element coding GSM	Information element coding DECT	Ref	Map status	NOTE
	Location area identification	Location area	.	M	
1	Location area identification IEI	ID for Location area	6.1.8.1.4	M	
2	-	Length of contents			
3	-	Location information type			NOTE
4	-	Location area level			NOTE
5	-	Extended location information type			NOTE
6	- Mobile Country Code - - Mobile Network Code - - Location Area Code	Extended location information	6.1.8.1.11	M	
NOTE: All values are set to support the GSM Location Area Identification.					



6.1.7.1.5 Identity type - identity type

Table 69

Item No	Information element coding GSM	Information element coding DECT	Ref	Map status	NOTE
	Identity type	Identity type	.	M	
1	Identity type IEI	ID for Identity type	6.1.8.1.4	M	
2	-	Length of contents		-	
3	Type of identity	Identity group	6.1.8.1.12	M	NOTE
4	Type of identity	Type	6.1.8.1.13	M	NOTE

NOTE: Type of identity mapping to Identity group and/or type depends on the requested identity.

6.1.7.1.6 Reject cause - reject reason

Table 70

Item No	Information element coding GSM	Information element coding DECT	Ref	Map status	NOTE
	REJECT cause	Reject reason	.	M	
1	Reject cause IEI	ID for Reject reason	6.1.8.1.4	M	
2	reject cause value	Reject reason code	6.1.8.1.17	M	

6.1.7.1.7 Bearer capabilities 1 - basic service

Table 71

Item No	Information element coding GSM	Information element coding DECT	Ref.	Map status	NOTE
	<b>Bearer capabilities 1</b>	Basic service		M	
1	Bearer capability IEI	ID for basic service	6.1.8.1.4	M	
2	Length of Bearer capabilities contents	-		X	
3	Radio channel requirement	-		X	
4	Coding standard	-		X	
5	Transfer mode	-		X	
7	Information transfer capability	Basic service	6.1.8.1.19	M	
8	coding standard ext.	-		I	
9-29	etc.	-		I	

6.1.7.1.8 Progress indicator - progress indicator

Table 72

Item No	Information element coding GSM	Information element coding DECT	Ref.	Map status	NOTE
	Progress indicator	progress indicator		M	
1	Progress indicator IEI	ID for progress indicator	6.1.8.1.4	M	
2	length of progress indicator contents	length of contents	6.1.8.1.5	M	
3	coding standard	coding standard	6.1.8.1.18	M	
4	location	location	6.1.8.1.20	M	
5	progress description	progress description	6.1.8.1.21	M	

6.1.7.1.9 Cause - release reason

Table 73

Item No	Information element coding GSM	Information element coding DECT	Ref.	Map status	NOTE
	cause	release reason		M	
1	Cause IEI	ID for release reason	6.1.8.1.4	M	
2	length of cause contents	-		X	
3	coding standard	-		I	
4	location	-		I	
5	recommendation	-		I	
6	cause value	release reason code	6.1.8.1.22	M	
7	diagnostic	-		I	

6.1.7.1.10 Reject cause - release reason

Table 74

Item No	Information element coding GSM	Information element coding DECT	Ref.	Map status	NOTE
	Reject cause	release reason		M	
1	Reject cause IEI	ID for release reason	6.1.8.1.4	M	
2	reject cause value	release reason code	6.1.8.1.25	M	

6.1.7.1.11 Signal - signal

Table 75

Item No	Information element coding GSM	Information element coding DECT	Ref.	Map status	NOTE
	signal	signal		M	
1	Signal IEI	ID for signal	6.1.8.1.4	M	
2	signal value	signal value	6.1.8.1.23	M	

6.1.7.1.12 Keypad facility - multi display

Table 76

Item No	Information element coding GSM	Information element coding DECT	Ref.	Map status	NOTE
	Keypad facility	Multi Display			
1	Keypad facility IEI	ID for Multi keypad	6.1.8.1.4	M	
2		Length of contents	6.1.8.1.5	M	NOTE 1
3	Keypad information	Display info (DECT characters)		M	NOTE 2

NOTE 1: The FP shall set the length of contents field to the appropriate value, depending on the conveyed information to the PP (see NOTE 2).  
 NOTE 2: The FP shall convey the appropriate information to the PP. The detailed mapping for data sent by the FP at the DECT air interface is however not defined in this ETS.

6.1.7.1.13 Cause - multi display

Table 77

Item No	Information element coding GSM	Information element coding DECT	Ref.	Map status	NOTE
	Cause	Multi Display			
1	Cause IEI	ID for Multi keypad	6.1.8.1.4	M	
2	Length of Cause contents	length of contents	6.1.8.1.5	M	
3	Coding standard	-		I	
4	Location	-		I	
5	Recommendation	-		I	
6	Cause Value	Display info (DECT characters)		M	NOTE 1
7	Diagnostic	-		I	
NOTE 1: The FP shall convey the appropriate information to the PP, as specified in subclause 6.1.5.1. The detailed mapping for data sent by the FP at the DECT air interface is however not defined in this ETS.					

6.1.7.1.14 Layer 3 information - fixed identity

Table 78

Item No	Information element coding GSM	Information element coding DECT	Ref	Map status	NOTE
	Layer 3 Information	Fixed Identity			
1	Layer 3 Information IEI	-		-	
2	Length	-		-	
<b>Layer 3 Information</b>					
3	RR Management Protocol Discriminator	-		I	
4	Skip Indicator	-		I	
5	Handover Command Message Type	-		I	NOTE 1
6	Fixed identity	Fixed Identity		M	NOTE 2
7	Network Parameter	-		I	
NOTE 1: Shall indicate Handover Command Message Type, See ETS 300 557 [21] (GSM 04.08).					
NOTE 2: Fixed Identity is included as DECT/GSM unique element in the GSM RR Handover Command Message, see subclause 6.1.2.9.4.					

6.1.7.1.15 Layer 3 information - network parameter

Table 79

Item No	Information element coding GSM	Information element coding DECT	Ref	Map status	NOTE
	Layer 3 Information	Network Parameter			
1	Layer 3 Information IEI	-		-	
2	Length	-		-	
	<b>Layer 3 Information</b>				
3	RR Management Protocol Discriminator	-		I	
4	Skip Indicator	-		I	
5	Handover Command Message Type	-		I	NOTE 1
6	Fixed identity	-		I	
	<b>Network Parameter</b>				NOTE 3
7	ID for Network Parameter	ID for Network Parameter	6.1.8.1.4	M	
8	Length of element	Length of element	6.1.8.1.5	M	
9	Discriminator	Discriminator		M	NOTE 4
10	Data	Data		M	NOTE 2
NOTE 1:	Shall indicate Handover Command Message Type, See ETS 300 557 [21] (GSM 04.08).				
NOTE 2:	Shall indicate 'Network handover reference', handover reference is coded using binary representation. See DECT Base Standard ETS 300 175-5 [5] subclause 15.7 for detailed coding.				
NOTE 3:	Network Parameter is included as unique element for this ETS, conveyed transparently in the GSM RR Handover Command Message, see subclause 6.1.2.9.4.				
NOTE 4:	Set value to handover reference, GSM network #6A.				

6.1.7.1.16 Notification indicator - multi display

Table 79a

Item No	Information element coding GSM	Information element coding DECT	Ref	Map status	NOTE
	Notification Indicator	Multi Display			
1	Notification indicator IEI	ID for Multi Display	6.1.8.1.4	M	
2	-	Length of contents	6.1.8.1.5	M	
3	Notification description	Display info (DECT characters)		M	NOTE 1
NOTE 1:	The FP shall convey the appropriate information to the PP. The detailed mapping for data sent by the FP at the DECT air interface is however not defined in this ETS.				

6.1.7.2 DECT to GSM

6.1.7.2.1 Portable identity - mobile identity

Table 80

Item No	Information element coding DECT	Information element coding GSM	Ref	Map status	NOTE
	Portable identity	Mobile identity	.	M	
1	ID for Portable identity	Mobile identity IEI	6.1.8.2.4	M	
2	Length of contents	Length of contents	6.1.8.2.5	M	
3	Length of identity value	Odd/even indication = "0"	6.1.8.2.6	M	
4	Type	Type of identity	6.1.8.2.7	M	NOTE
5	Portable User Type	Type of identity	6.1.8.2.8	M	NOTE
6	Identity value	Identity digits	6.1.8.2.9	M	

NOTE: "Type" and "Portable user type" - fields are mapped as a pair to the GSM "type of identity": "IMSI".

6.1.7.2.2 Network assigned identity- mobile identity

Table 81

Item No	Information element coding DECT	Information element coding GSM	Ref	Map status	NOTE
	Network assigned identity	Mobile identity	.	M	
1	ID for Network assigned identity	Mobile identity IEI	6.1.8.2.4	M	
2	Length of contents	Length of contents	6.1.8.2.5	M	
3	-	Odd/even indication = "0"		-	
4	Type	Type of identity	6.1.8.2.10	M	
5	Length of identity value = "32"	-		-	
6	Identity value	Identity digits	6.1.8.2.11	M	

6.1.7.2.3 Location area - location area identification

Table 82

Item No	Information element coding DECT	Information element coding GSM	Ref	Map status	NOTE
	Location area	Location area identification		M	
1	ID for Network assigned identity	Mobile identity IEI	6.1.8.2.4	M	
2	Length of contents	Length of contents	6.1.8.2.5	M	
3	Location information type	-		X	NOTE
4	Location area level	-		X	NOTE
5	Extended location information type	-		X	NOTE
6	Extended location information	- Mobile Country Code - Mobile Network Code - Location Area Code	6.1.8.2.12	M	NOTE

NOTE: All values are set to support the GSM Location Area Identification. Note, that CI value (DECT) ignored.

6.1.7.2.4 Cipher info - cipher key sequence number

Table 83

Item No	Information element coding DECT	Information element coding GSM	Ref	Map status	NOTE
	Cipher info	Cipher key sequence number		M	
1	ID for Cipher info	Cipher key sequence number IEI	6.1.8.2.4	M	
2	Length of contents	-		X	
3	Y/N bit; Enable/disable ciphering	-		-	
4	Cipher algorithm identifier	-		-	
5	Proprietary algorithm identifier	-		X	
6	Cipher key type	-		-	
7	Cipher key number	Ciphering key sequence number	6.1.8.2.13	M	

6.1.7.2.5 RES - Auth. parameter SRES

Table 84

Item No	Information element coding DECT	Information element coding GSM	Ref	Map status	NOTE
	RES	Auth parameter SRES		M	
1	ID for RES	Auth parameter SRES IEI	6.1.8.2.4	M	
2	-	Length of contents		-	NOTE
3	RES field	Auth parameter SRES field	6.1.8.2.14	M	

NOTE: The length is always 32 bits.

6.1.7.2.6 Portable identity- mobile identity

Table 85

Item No	Information element coding DECT	Information element coding GSM	Ref	Map status	NOTE
	Portable identity	Mobile identity			
1	ID for Portable identity	Mobile identity IEI	6.1.8.2.4	M	
2	Length of contents	Length of contents	6.1.8.2.5	M	
3	Type	Type of identity	6.1.8.2.15	M	
4	Length of identity value	Odd/even indication = "0"	6.1.8.2.6	M	
5	Identity value	Identity value		M	NOTE 1

NOTE 1: If the <type> field value in item 3 is set to value "0000000"B the mapping of <identity value> shall be done as shown in subclause 6.1.8.2.9 (IMSI). If the <type> field value in item 3 is set to value "0010000"B the mapping of IPEI to IMEI shall be done as described in Annex C

6.1.7.2.7 Basic service - CM service type

Table 86

Item No	Information element coding DECT	Information element coding GSM	Ref	Map status	NOTE
	Basic service	CM service type			
1	ID for Basic service	CM service type IEI	6.1.8.2.4	M	
2	Call class	service type	6.1.8.2.16	M	

6.1.7.2.8 Basic service - bearer capabilities

Table 87

Item No	Information element coding DECT	Information element coding GSM	Ref.	Map status	NOTE
	Basic service	Bearer capabilities			
1	ID for Basic service	Bearer capabilities IEI	6.1.8.1.4	M	
2	-	Length of Bearer capabilities contents		X	
3	-	Radio channel requirement		-	Default value = 10
4	-	Coding standard		-	Default value = 0
5	-	Transfer mode		-	Default value = 0
7	Basic service	Information transfer capability	6.1.8.2.17	M	
8-...	-	etc.		I	

6.1.7.2.9 Called-party-number - called-party-number

Table 88

Item No	Information element coding DECT	Information element coding GSM	Ref.	Map status	NOTE
	Called party number	Called party BCD number			
1	ID for called party number	info element ID	6.1.8.1.4	M	
2	length of contents	length of called party number contents	6.1.8.1.5	M	
3	number type	type of number	6.1.8.2.18	M	
4	numbering plan identification	numbering plan identification	6.1.8.2.19	M	
5	called party address (DECT char)	number digits (IA5 char)		M	DECT char to IA5 char

6.1.7.2.10 Multi keypad - called-party-number

Table 89

Item No	Information element coding DECT	Information element coding GSM	Ref.	Map status	NOTE
	Multi keypad	Called party BCD number			
1	ID for Multi keypad	Called party BCD number IEI	6.1.8.1.4	M	
2	length of contents	length of called party number contents	6.1.8.1.5	M	
3	-	type of number		-	
4	-	numbering plan identification		-	
5	keypad info (DECT char)	number digits (IA5 char)		M	DECT char to IA5 char

6.1.7.2.11 Multi keypad - keypad facility (F-10)

Table 90

Item No	Information element coding DECT	Information element coding GSM	Ref.	Map status	NOTE
	multi-keypad	keypad facility			
1	ID for Multi keypad	Keypad facility IEI	6.1.8.1.4	M	
2	length of contents	length of keypad contents	6.1.8.1.5	M	
3	keypad info (DECT char)	keypad info (IA5 char)	-	M	single DECT char (0-9,A,B,C,D,*,# only) at a time into IA5 char All other DECT chars not mapped.

6.1.7.2.12 Release reason - cause

Table 91

Item No	Information element coding DECT	Information element coding GSM	Ref.	Map status	NOTE
	release reason	cause			
1	ID for release reason	Cause IEI	6.1.8.1.4	M	
2	-	length of cause contents		X	
3	-	coding standard		X	set coding standard to 11 (GSM)
4	-	location		X	set to network beyond interworking point?
5	-	recommendation		X	not included
6	release reason code	cause value	6.1.8.2.20	M	
7	-	diagnostic		I	For SS and bearer service negotiation



6.1.7.2.13 Info type - cause

Table 92

Item No	Information element coding DECT	Information element coding GSM	Ref	Map status	NOTE
	Info Type	Cause			
1	ID for Info Type	Cause IEI	6.1.8.2.4	M	
2	Length of contents	Length	6.1.8.2.5	M	
3	Parameter type(s)	Cause Value		M	NOTE
NOTE: DECT coding of 'handover failure, reversion to old channel' as defined in DECT base standard shall be mapped to GSM 'radio interface failure, reversion to old channel' as defined in ETS 300 590 [23] (GSM 08.08).					

6.1.8 Fields in information element coding

The subclause titles in this subclause refer to the DECT field name if only one field name is used.

If a note contains the phrase "Value is mapped transparently", this implies that the FP IWU shall process the information element/field value in a way which the most significant bits or digits versus least significant are kept in alignment on both sides of the FP IWU.

6.1.8.1 GSM to DECT

6.1.8.1.1 Protocol discriminator - protocol discriminator

Table 93

Item No	Field(s) coding GSM	Field(s) coding DECT	Ref	Map status	NOTE
	Protocol discriminator	Protocol discriminator			
1	-	"0000"B			LCE
2	"0011"B	"0011"B		M	CC, (CRSS)
3	-	"0100"B		I	(CISS)
4	"0101"B	"0101"B		M	MM
5	-	"0110"B		I	CLMS
6	-	"0111"B		I	COMS
7	-	"1???"B		-	unknown
CISS: Call Independent Supplementary Services CLMS: Connectionless Message Service COMS: Connection Oriented Message Service CRSS: Call Related Supplementary Services					

6.1.8.1.2 Transaction identifier - transaction identifier

Table 94

Item No	Field(s) coding GSM	Field(s) coding DECT	Ref	Map status	NOTE
	Transaction identifier	Transaction identifier			
1	Transaction flag	Transaction flag		C1	note 1
2	Transaction flag	Extended transaction value		C2	note 3
3	Transaction value	Transaction value		C1	note 2
4	Transaction value	Extended transaction value		C2	note 4
NOTE 1: The transaction flag value is mapped transparently through the FP during all procedures. NOTE 2: Shall be transparent. NOTE 3: GSM Transaction flag corresponds to DECT Original transaction flag (OTF) in Extended transaction value field (TVX), see subclause 6.3.2.7.8 NOTE 4: GSM Transaction value corresponds to DECT Original Transaction value (OTV) in Extended transaction value field (TVX), see subclause 6.3.2.7.8 C1: Mandatory (M) during normal transaction handling, otherwise out-of-scope (I). C2: Mandatory (M) during external handover call setup and subsequent messages, otherwise out-of-scope (I).					

6.1.8.1.3 Message type - message type

The messages mapping is dependent on which procedure and state the FT is in. The table which refers to this subclause shows which message types shall be mapped with each other.

The N(SD) bit in the GSM network side shall be incremented (independent of DECT) according to the rules as defined in ETS 300 557 [21] (GSM 04.08) every time the FP IWU sends a MM or a CC message to the MSC. The N(SD) bit is not mapped to the DECT air interface.

6.1.8.1.4 Id for info element (IEI) - id for info element

The element identifier mapping is depending of which message it is sent in. The table which refers to this subclause shows which element identifiers shall be mapped with each other.

6.1.8.1.5 Length of contents - length of contents

Unless explicitly stated in this standard, the value of this field should be mapped in alignment with the appropriate standard.

6.1.8.1.6 Type, (Mobile identity, NWK assigned identity)

Table 95

Item No	Field(s) coding GSM	Field(s) coding DECT	Ref	Map status	NOTE
	Type of identity	Type			
1	"100"	"1110100"		M	

6.1.8.1.7 Identity value, (mobile identity, NWK assigned identity)

Table 96

Item No	Field(s) coding GSM	Field(s) coding DECT	Ref	Map status	NOTE
	Identity value	Identity value			
1	4 octets, binary	4 octets, binary		M	Value is mapped transparently.

6.1.8.1.8 Y/N bit (encryption information - cipher info)

Table 97

Item No	Field(s) coding GSM	Field(s) coding DECT	Ref	Map status	NOTE
	Algorithm identifier	Y/N bit			
1	"00000001"				note
2	"0000011" or other version of GSM user encryption data.	"1"		M	Enable encryption

NOTE: This value is not mapped. In this case the FP IWU will respond with a CIPHER MODE COMPLETE message to the MSC (see ETS 300 499 [28]).

6.1.8.1.9 RAND field (RAND - RAND)

Table 98

Item No	Field(s) coding GSM	Field(s) coding DECT	Ref	Map status	NOTE
	RAND value	RAND field			
1	128 bits	128 bits		M	Value is mapped transparently

6.1.8.1.10 Cipher key number (key sequence - cipher key number)

Table 99

Item No	Field(s) coding GSM	Field(s) coding DECT	Ref	Map status	NOTE
	Key sequence	Cipher key number			
1	Three bits, values from "000"B to "110"B, "111"B reserved	Four bits, most significant bit is set to value "0"B		M	Value is mapped transparently

6.1.8.1.11 Extended location information (location area identification - location area)

Table 100

Item No	Field(s) coding GSM	Field(s) coding DECT	Ref	Map status	NOTE
	Location area identification	Extended location information			note 1
1	Mobile Country Code BCD coded digits 1, 2 and 3	Mobile Country Code BCD coded digits 1, 2 and 3		M	note 2
2.	Mobile Network Code, BCD coded digits 1, 2 and 3	Mobile Network Code, BCD coded digits 1, 2 and 3		M	note 2
3.	Location Area Code, 2 octets (hexadecimal, binary)	Location Area Code, 2 octets (hexadecimal, binary)		M	note 2
4.	-	Cell Identifier			note 3
NOTE 1: "Location area identification" is the value (field) of the <<Location area identification>> information element.					
NOTE 2: Value is mapped transparently.					
NOTE 3: This an arbitrary value generated at the FT. The value has no relevance for this ETS.					

6.1.8.1.12 Identity group (identity type - identity type)

Table 101

Item No	Field(s) coding GSM	Field(s) coding DECT	Ref	Map status	NOTE
	Type of identity	Identity group			
1	"001"B	"0000"B		M	IMSI-Portable id
2	"010"B	"0000"B		M	IMEI-Portable id
3	"100"B	"0001"B		M	TMSI-NWK assigned id

6.1.8.1.13 Type (identity type - identity type)

Table 102

Item No	Field(s) coding GSM	Field(s) coding DECT	Ref	Map status	NOTE
	Type of identity	Type			
1	"001"B	"0000000"B		M	IMSI-IPUI
2	"010"B	"0010000"B		M	IMEI-IPEI
3	"100"B	"1110100"B		M	TMSI-GSM temporary subscriber id

6.1.8.1.14 Type, (mobile identity, portable identity)

Table 103

Item No	Field(s) coding GSM	Field(s) coding DECT	Ref	Map status	NOTE
	Type of identity	Type			
1	"001"	"0000000"		M	IMSI

6.1.8.1.15 Portable user type, (mobile identity, portable identity)

Table 104

Item No	Field(s) coding GSM	Field(s) coding DECT	Ref	Map status	NOTE
	Type of identity	Portable user type			
1	"001"	"0100"		M	IMSI

6.1.8.1.16 Identity value, (mobile identity - portable identity)

Table 105

Item No	Field(s) coding GSM	Field(s) coding DECT	Ref	Map status	NOTE
	Identity value	Identity value			
1	maximum of 15 BCD coded digits	maximum of 64 bits representing a maximum of 15 BCD coded digits		M	IMSI

6.1.8.1.17 Reject cause value - reject reason code

Table 106

Item No	Field(s) coding GSM	Field(s) coding DECT	Ref	Map status	NOTE
	Reject cause value	Reject reason code			
1	"00000010"B	"02" (HEX)		M	
2	"00000011"B	"06" (HEX)		M	
3	"00000110"B	"05" (HEX)		M	
4	"00001011"B	"76" (HEX)		M	
5	"00001100"B	"80" (HEX)		M	
6	"00001101"B	"81" (HEX)		M	

6.1.8.1.18 Coding-standard - coding-standard

Table 107

Item No	Field(s) coding GSM	Field(s) coding DECT	Ref.	Map status	NOTE
	coding standard	coding standard			
1	"00"B	"00"B		M	CCITT standard
2	"01"B	"01"B		I	other int. stand
3	"10"B	"10"B		I	nat. standard
4	"11"B	"00"B		M	GSM. specific (Equivalent to ISDN)

6.1.8.1.19 Information transfer capability - basic service

Table 108

Item No	Field(s) coding GSM	Field(s) coding DECT	Ref.	Map status	NOTE
	Information transfer capability	Basic service			
1	"000"B	"0100"B		M	DECT/GSM IWP (phase 2)
2	"001"B	-		X	unrestricted dig
3	-	-		I	3,1 kHz audio
4	"011"B	-		X	group 3 fax
5	"111"B	-		X	reserved; the meaning is alternate speech/facsimile group 3

6.1.8.1.20 Location - location

Table 109

Item No	Field(s) coding GSM	Field(s) coding DECT	Ref.	Map status	NOTE
	location	location			
1	"0000"B	"0000"B		M	user
2	"0001"B	"0001"B		M	pr.net.loc.user
3	"0010"B	"0010"B		M	pu.net.loc.user
4	"0100"B	"0100"B		M	pu.net.rem.user
5	"0101"B	"0101"B		M	pr.net.rem.user
6	"1010"B	"1010"B		M	net.beyond interw. point

6.1.8.1.21 Progress-description - progress-description

Table 110

Item No	Field(s) coding GSM	Field(s) coding DECT	Ref.	Map status	NOTE
	progress description	progress description			
1	"0000001"B	"0000001"B		M	not end-to-end ISDN
2	"0000010"B	"0000010"B		M	dest.non-ISDN
3	"0000011"B	"0000011"B		M	orig.non-ISDN
4	"0000100"B	"0000100"B		M	return.to ISDN
5	"0001000"B	"0001000"B		M	in-band or appr. pattern availab.
6	"0100000"B	"0100000"B		M	Call is end to end PLMN/ISDN.

6.1.8.1.22 Cause-value - release-reason-code

Table 111

Item No	Field(s) coding GSM	Field(s) coding DECT	Ref.	Map status	NOTE
	cause value	release reason code			
1	"0010000"B	"00000000"B		M	16 to 00-norm.
2	"0110001"B until "1001111"B	"00000110"B		M	49-79 to 06-not implemented
3	"0011111"B	"00001111"B		M	31 to 0F-unkn.
4	"0010010"B	"00011000"B		M	18 to 10-detac.
5	"0000011"B	"00010001"B		M	3 to 11-no rou.
6	"0000001"B	"00010010"B		M	1 to 12-user unknown
7	"0010001"B	"00010100"B		M	17 to 14-busy
8	"0010101"B	"00010101"B		M	21 to 15-reject.
9	"0100010"B until "0101111"B	"00110010"B		M	34-47 to 32- insufficient resources

6.1.8.1.23 Signal value - signal value

Table 112

Item No	Field(s) coding GSM	Field(s) coding DECT	Ref.	Map status	NOTE
	signal value	signal value			
1	"00000000"B	"00000000"B		M	dial tone on
2	"00000001"B	"00000001"B		M	ring-back tone on
3	"00000010"B	"00000010"B		M	interc. tone on
4	"00000011"B	"00000011"B		M	net.con.tone on
5	"00000100"B	"00000100"B		M	busy tone on
6	"00000101"B	"00000101"B		M	confirm tone on
7	"00000110"B	"00000110"B		M	answer tone on
8	"00000111"B	"00000111"B		M	call wait.tone on
9	"00001000"B	"00001000"B		M	off-hook warn. tone on
10	"00111111"B	"00111111"B		M	tones off
11	"01001111"B	"01001111"B		M	alerting off

6.1.8.1.24 Skip indicator - transaction identifier

Table 113

Item No	Field(s) coding GSM	Field(s) coding DECT	Ref	Map status	NOTE
	Skip indicator	Transaction identifier			
1	'0'B (bit 8)	Transaction flag		M	note 1
2	'000'B (bits 6, 7, 5)	Transaction value		M	note 2
NOTE 1: The transaction flag value is mapped according to the rules defined in ETS 300 175-5 [5] subclause 7.3.					
NOTE 2: Shall be transparent.					

6.1.8.1.25 Reject cause value - release reason code

Table 114

Item No	Field(s) coding GSM	Field(s) coding DECT	Ref	Map status	NOTE
	Reject cause value	Release reason code			
1	"00000100"B	"0A"(HEX)		M	note 1
2	"00000110"B	"08" (HEX)		M	notes 1, 2
3	"00010001"B	"0F" (HEX)		O	notes 1, 2
4	"00010110"B	"34" (HEX)		O	note 1
5	"00100000"B	"06" (HEX)		O	note 1
6	"00100001"B	"0F" (HEX)		O	note 1
7	"00100010"B	"0F" (HEX)		O	note 1
NOTE 1: These values apply when the Reject cause is included in a CM service reject message.					
NOTE 2: These values apply when the Reject cause is included in an Abort message.					

6.1.8.2 DECT to GSM

6.1.8.2.1 Protocol discriminator - protocol discriminator

See subclause 6.1.8.1.1.

6.1.8.2.2 Transaction identifier - transaction identifier

See subclause 6.1.8.1.2.

6.1.8.2.3 Message type - message type

See subclause 6.1.8.1.3.

6.1.8.2.4 Id for info element - id for info element (IEI)

See subclause 6.1.8.1.4.

6.1.8.2.5 Length of contents - length of contents

See subclause 6.1.8.1.5.



6.1.8.2.6 Length of identity value (portable identity - mobile identity)

Table 115

Item No	Field(s) coding DECT	Field(s) coding GSM	Ref	Map status	NOTE
	Length of identity value	Odd/even indication			
1	Binary value representing the length of BCD coded digits	"0" or "1" depending if the number of BCD coded digits is odd or even"		M	

6.1.8.2.7 Type, (portable identity - mobile identity)

Table 116

Item No	Field(s) coding DECT	Field(s) coding GSM	Ref	Map status	NOTE
	Type	Type of identity			
1	"0000000"	"001"		M	

6.1.8.2.8 Portable user type, (portable identity - mobile identity)

Table 117

Item No	Field(s) coding DECT	Field(s) coding GSM	Ref	Map status	NOTE
	Portable user type	Type of identity			
1	"0100"	"001"		M	

6.1.8.2.9 Identity value, (portable identity - mobile identity)

Table 118

Item No	Field(s) coding DECT	Field(s) coding GSM	Ref	Map status	NOTE
	Identity value	Identity value			
1	maximum of 60 bits representing a maximum of 15 BCD coded digits	maximum of 15 BCD coded digits		M	Value is mapped transparently

6.1.8.2.10 Type, (NWK assigned identity - mobile identity)

Table 119

Item No	Field(s) coding DECT	Field(s) coding GSM	Ref	Map status	NOTE
	Type	Type of identity			
1	"1110100"	"100"		M	

6.1.8.2.11 Identity value, (NWK assigned identity - mobile identity)

Table 120

Item No	Field(s) coding DECT	Field(s) coding GSM	Ref	Map status	NOTE
	Identity value	Identity value			
1	4 octets, binary	4 octets, binary		M	Value is mapped transparently.

6.1.8.2.12 Extended location information, (location area - location area identification)

Table 121

Item No	Field(s) coding DECT	Field(s) coding GSM	Ref	Map status	NOTE
	Extended location information	Location area identification			note 1
1	Mobile Country Code BCD coded digits 1,2 and 3	Mobile Country Code BCD coded digits 1,2 and 3		M	note 2
2.	Mobile Network Code, BCD coded digits 1,2	Mobile Network Code, BCD coded digits 1,2		M	note 2
3	Location Area Code, 2 octets (hexadecimal, binary)	Location Area Code, 2 octets (hexadecimal, binary)		M	note 2
4	Cell Identifier	-		I	note 3
NOTE 1: "Location area identification" is the value (field) of the <<Location area identification>> information element.					
NOTE 2: Value is mapped transparently.					
NOTE 3: This value is terminated at the FT (not used).					

6.1.8.2.13 Cipher key number, (cipher info - cipher key sequence number)

Table 122

Item No	Field(s) coding DECT	Field(s) coding GSM	Ref	Map status	NOTE
	Cipher key number	Cipher key sequence number			
1	A four bit binary value	A three bit binary value		M	note
NOTE: Value is mapped transparently. The Most Significant Bit (MSB) of the <Cipher key number> field shall be of value "0".					

6.1.8.2.14 RES field (RES - auth. parameter SRES)

Table 123

Item No	Field(s) coding DECT	Field(s) coding GSM	Ref	Map status	NOTE
	RES field	Auth. parameter SRES field			
1	RES value	SRES value		M	Value is mapped transparently.

6.1.8.2.15 Type, (portable identity - mobile identity)

Table 124

Item No	Field(s) coding DECT	Field(s) coding GSM	Ref	Map status	NOTE
	Type	Type of identity			
1	"0000000"B	"001"B		M	
2	"0010000"B	"010"B		M	note

NOTE: The IPEI structure is different from the IMEI structure the mapping is specified in Annex C.

6.1.8.2.16 Call class, (basic service - CM service type)

Table 125

Item No	Field(s) coding DECT	Field(s) coding GSM	Ref	Map status	NOTE
	Call class	Service type			
1	"1000"B	"0001"B		M	Normal call setup
2	"1010"B	"0010"B		M	Emergency call setup
3	"1100"	-		-	External H/O call setup

6.1.8.2.17 Basic service - information transfer capability

Table 126

Item No	Field(s) coding DECT	Field(s) coding GSM	Ref.	Map status	NOTE
	Basic service	Information transfer capability			
1	"0100"B	"000"B		M	DECT/GSM IWP (phase 2)

6.1.8.2.18 Number-type - type-of-number

Table 127

Item No	Field(s) coding DECT	Field(s) coding GSM	Ref.	Map status	NOTE
	Number type	Type of number			
1	"000"B	"000"B		M	unknown
2	"001"B	"001"B		O	intern.number
3	"010"B	"010"B		O	national numb.
4	"011"B	"011"B		O	netw.spec.num
5	"100"B	"100"B		I	unknown
6	"110"B	"110"B		I	unknown
7	"111"B	"111"B		I	unknown

6.1.8.2.19      **Numbering-plan identification - numbering-plan identification**

Table 128

Item No	Field(s) coding DECT	Field(s) coding GSM	Ref.	Map status	NOTE
	Numbering plan identification	Numbering plan identification			
1	"0000"B	"0000"B		M	unknown
2	"0001"B	"0001"B		O	E.164/E.163
3	"0011"B	"0011"B		O	X.121 (data)
4	-	"0100"B		X	F.69 (Telex)
5	"1000"B	"1000"B		O	Nat.stand.plan
6	"1001"B	"1001"B		O	private plan
7	"1111"B	"1111"B		O	res.for extens.

6.1.8.2.20      **Release-reason-code - cause-value**

Table 129

Item No	Field(s) coding DECT	Field(s) coding GSM	Ref.	Map status	NOTE
	release reason code	cause value			
1	"00000000"B	"0010000"B		M	0 to 16-norm.
2	"00000101"B	"1011000"B		M	5 to 88 incomp.
3	"00000110"B	"1001111"B		M	6 to 79-not im
4	"00001111"B	"0011111"B		M	15 to 31-unkn.
5	"00010000"B	"0010010"B		M	16 to 18-detac.
6	"00010001"B	"0000011"B		M	17 to 3-no rou.
7	"00010010"B	"0000001"B		M	18 to 1-user unknown
8	"00010100"B	"0010001"B		M	20 to 17-busy
9	"00010101"B	"0010101"B		M	21 to 21-reject.
10	"00110010"B	"0101111"B		M	50 to 47-insufficient resources

6.1.8.2.21      **Transaction identifier - skip indicator**

Table 130

Item No	Field(s) coding DECT	Field(s) coding GSM	Ref	Map status	NOTE
	Transaction identifier	Skip indicator			
1	Transaction flag	0'B (bit 8)		M	always
2	Transaction value	000'B (bits 6, 7, 5)		M	always

## 6.2 FP U-Plane IWU procedures

For the FP GSM PLMN attachment, the DECT LU1 U-Plane service should be mapped into the GSM Pulse Coded Modulation (PCM) speech service. Requirements in subclause 8.3 of ETS 300 175-8 [8] shall be applied.

### 6.2.1 Service activation

The FP IWU shall activate the DECT U-Plane between the FP and the PP upon or before the receipt of:

- 1) GSM Connect for outgoing call;
- 2) GSM Connect-ack for incoming call;
- 3) During call establishment phases, GSM <<Progress indicator>> information element with progress description indicating "Call is not end-to-end PLMN/GSM further call information may be available in-band", "Destination address is non-PLMN/ISDN", "Origination address is non-PLMN/ISDN", or "In band information or appropriate pattern now available" for incoming or outgoing call.
- 4) During call release phases, GSM <<Progress indicator>> information element with progress description indicating "In band information or appropriate pattern now available" for incoming or outgoing call.

The U-Plane activation shall be co-ordinated by the FP IWU such that both the DECT FT part and GSM part do not cause unnecessary noise to the calling and called party.

NOTE: The procedure for selecting and identification of the U-Plane channels to be used between the FP and the GSM PLMN on the lower layer interconnection of those entities, and thus the necessary signalling information transfer at call establishment, is outside the scope of this ETS.

## 6.3 PP C-Plane IWU mappings

### 6.3.1 Call handling IWU procedures

With the exceptions given in this subclause, the CC procedures shall be performed as defined in GAP or if not covered by GAP as defined in ETS 300 175-5 [5].

#### 6.3.1.1 Call establishment procedure

##### 6.3.1.1.1 Outgoing call

Prior to issuing a MNCC\_SETUP-req primitive to the PT in order to establish an outgoing call, the PP IWU shall retrieve the GSM Cipher key sequence number from the SIM/DAM GA and map it to the <Cipher key number> field in the <<CIPHER INFO>> information element which shall be sent in the {CC-SETUP} message to the FP. The <Basic service> field in the <<BASIC SERVICE>> information element shall be set to value "0100"B (GSM profile). In ARI-D environment the <<FIXED IDENTITY>> information element shall still be included in the {CC-SETUP} message but with 0 length contents.

If the received {CC-SETUP-ACK} message contains a <<DELIMITER-REQUEST>>, the PP IWU shall indicate the completion of the dialling information with a <<SENDING COMPLETE>> information element.

##### 6.3.1.1.2 Emergency call

Prior to issuing a MNCC\_SETUP-req primitive to the PT in order to establish an outgoing emergency call and an IPUI type R is not available, the PP IWU shall retrieve the IPUI type N (IPEI) from the Portable Equipment (PE) which shall be sent as portable identity in the {CC-SETUP} message to the FP.

NOTE: The mapping between the IPEI and GSM IMSI, used in the Emergency call setup, may be found in Annex C.

### 6.3.1.1.3 Incoming call

If the PP receives a {CC-SETUP} message indicating a <<BASIC SERVICE>> information element, it does not support, the PP shall respond with a {CC-RELEASE-COM} message with <<RELEASE REASON>> H05 "incompatible service".

### 6.3.1.2 Call release/reject procedures

Upon receipt of a MNCC\_RELEASE-ind or a MNCC\_REJECT-ind primitive, reflecting respectively a {CC-RELEASE} or a {CC-RELEASE-COM} message being received by the PT, the PP IWU shall act as follows depending of the <<RELEASE REASON>> value:

a) "Unknown identity":

- shall delete the LAI, Cipher key, Cipher key number and TMSI as defined in annex B;
- shall accomplish the relevant release procedure;
- shall initiate location registration procedure after the link has been released.

b) "Invalid identity":

- shall delete the LAI, Cipher key, Cipher key number and TMSI as defined in annex B;
- shall accomplish the relevant release procedure;
- shall not initiate outgoing calls except emergency calls;
- shall not initiate detach procedure;
- shall set the update status to ROAMING NOT ALLOWED.

c) Any other release reason

the PP IWU shall react in a way that the reaction of PT as it is described in ETS 300 444 [9] to be achieved.

### 6.3.2 Other IWU procedures

This subclause defines the interworking procedures in the PP relating to the associated DECT and DAM related interaction and their relation to the DECT air interface MM procedures.

The PP procedures do not refer to mapping tables but are described in the procedure it self. The DAM GSM application part (SIM/DAM GA) refers to the GSM specific part of the DAM functions or the associated elementary files in a GSM SIM.

NOTE: The SIM/DAM GA is a functional entity and does not refer to a physical implementation see ETS 300 331 [10].

If no mappings are defined for data at the DECT air interface which is being received or sent (as being mandatory by the GAP or this ETS) the handling of this data is described in the procedure itself. If not, the data shall be either ignored or, if covered by the GAP, shall be processed accordingly.

The general layout of the procedures is described in figure 36.

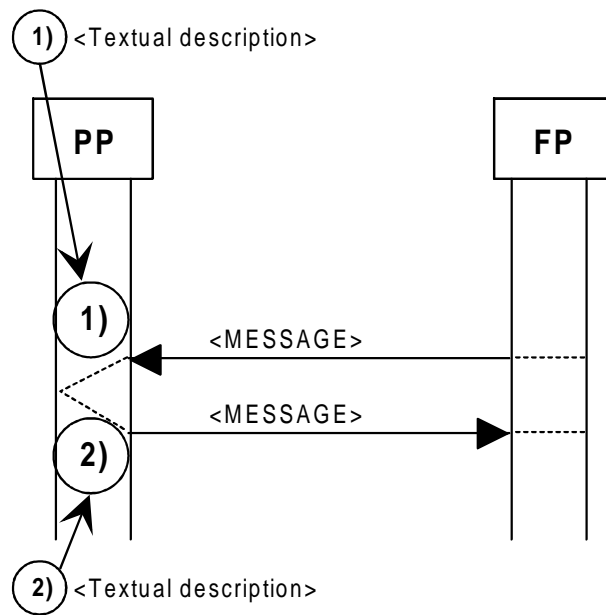

Figure 36: General layout of the procedures in the PP

### 6.3.2.1 Authentication procedure

- 1) Upon receipt of a MM\_AUTHENTICATE-ind primitive from the PT as a result of a received {AUTHENTICATION-REQUEST} message from the FT (figure 37) the PP IWU shall send the received <<RAND>> information element to the SIM/DAM GA. The SIM/DAM GA shall calculate the <<RES>> and the standard GSM ciphering key Kc by using the associated GSM authentication algorithm and shall send the <<SRES>> information element and the Kc to the PP IWU, after which the PP IWU shall store the Kc and the associated <<CIPHER KEY NUMBER>> in the SIM/DAM GA.

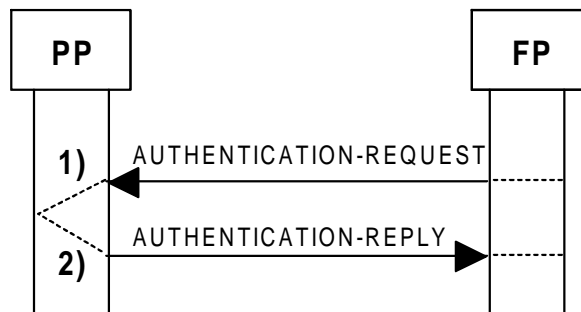

Figure 37: Authentication procedure

- 2) The PP IWU shall issue the MM\_AUTHENTICATE-res primitive to the PT. The PT sends a {AUTHENTICATION-REPLY} message to the FT including the calculated GSM <<SRES>> mapped transparently to the DECT <<RES>> information element.

If the PP IWU receives a MM\_AUTHENTICATE\_REJECT-ind primitive from the PT after sending the MM\_AUTHENTICATE-res primitive to the PT the PP IWU shall delete the GSM LAI, TMSI and the Cipher key sequence number from the SIM/DAM GA.

NOTE: The IWU deletes any elementary file (LAI, TMSI, etc.) in the SIM/DAM GA by storing it full of "1"Bs in the associated elementary file.

### 6.3.2.2 Identity procedure

- 1) Upon receipt of a MM\_IDENTITY-ind primitive from the PT as a result of a received {IDENTITY-REQUEST} message from the FT (figure 38) the PP IWU shall retrieve the required information either from the SIM/DAM GA or the PE.

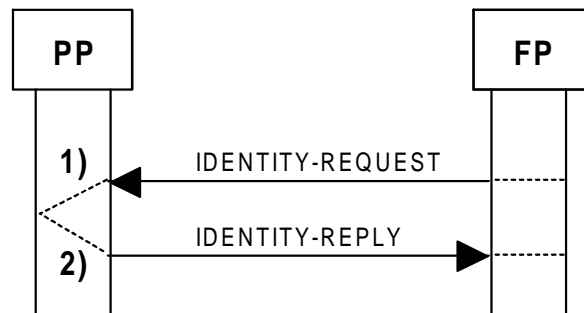

Figure 38: Identity procedure

If the <Identity group> field in the <<IDENTITY TYPE>> information element in the received {IDENTITY-REQUEST} message is set to value "0000" and:

- a) if the <type> field value is set to "0000000"B the PP IWU shall retrieve the IMSI from the SIM/DAM GA;
- b) if the <type> field value is set to "0010000"B the PP IWU shall retrieve the IPEI from the PE.

If the <Identity group> field is set to value "0001" and if the <type> field value is set to "1110100"B the PP IWU shall retrieve the TMSI from the SIM/DAM GA.

The PP IWU shall send the MM\_IDENTITY-res primitive to the PT. The PT shall either send the IMSI or the IPEI in the respective <<PORTABLE IDENTITY>> information element or the TMSI in the respective <<NWK ASSIGNED IDENTITY>> information element to the FT in the {IDENTITY-REPLY} message.

### 6.3.2.3 Location registration procedure

#### 6.3.2.3.1 General

The PP location updating procedure is a general procedure which is used for the following purposes:

- normal location updating (see subclause 6.3.2.3.2);
- periodic updating (see subclause 6.3.2.3.3);
- IMSI attach (see subclause 6.3.2.3.4).

The PP IWU does not distinguish between these three different types of procedures in the message coding. In all cases the generic location updating procedure as described in subclause 6.3.2.3.3. applies.

To limit the number of location updating attempts made, where location updating is unsuccessful, an attempt counter is used. The attempt counter is reset when a PP is switched on or a SIM/DAM GA is inserted. Upon successful location updating the PP sets the update status to UPDATED in the SIM/DAM GA and stores the received GSM Location Area Identification on the SIM/DAM GA. The attempt counter shall be reset (see subclause 6.3.2.3.5.2).

The location update procedure shall be performed as it is described in GAP with the additions described in this subclause.



#### **6.3.2.3.2 Normal location updating**

The normal location updating procedure is used to update the registration of the actual Location Area of a PP in the network. The normal location updating procedure shall also be started if the network indicates that the PP is unknown in the VLR as a response to connection establishment request.

The location updating procedure is always initiated by the PP.

#### **6.3.2.3.3 Periodic location updating**

Periodic location updating may be used to notify periodically the availability of the PP to the network. As already indicated in subclause 6.1.2.3. there are two ways to implement periodic location registration: one is based on a location update suggestion by the FP, the other is based on the use of the <<DURATION>> information element and a periodic timer in the PP. This last approach is described in this paragraph.

The procedure is controlled by the timer <MM loc\_upd.1> in the PP IWU. If the timer is not running already, it is started each time the PP IWU terminates the last active transaction. The timer is stopped when the PP IWU receives a network-layer message from the FP which is not related to an MM transaction.

The timer is reset to 0 when:

- a network-layer message is received which is not related to an MM transaction;
- the timer has expired;
- the MS is deactivated (i.e. equipment powered down or SIM/DAM GA removed).

When the timer reaches the <MM loc\_upd.1> time-out value the location updating procedure shall be started as soon as no MM transaction is active. The time-out value is the value received in the latest <<DURATION>> information element in a {LOCATE-ACCEPT} message.

NOTE: This is the first occasion where a new value will be used.

No location registration procedure may replace the periodic location registration, i.e. if timer <MM loc\_upd.1> expires during ongoing normal location registration procedure, the PP shall still initiate a periodic location registration as described above.

#### **6.3.2.3.4 IMSI attach procedure**

The IMSI attach procedure is the complement of the IMSI detach procedure (see subclause 6.3.2.4). It is used to indicate the IMSI as active in the network.

The normal location registration procedure used to implement an IMSI attach should be started by the PP IWU when an IMSI is activated in a PP (i.e. activation of a PP with plug-in SIM/DAM GA, insertion of a card in a card-operated PP etc.) within coverage area from the network or when a PP with an IMSI activated outside the coverage area enters the coverage area.

### 6.3.2.3.5 Generic location updating procedure

#### 6.3.2.3.5.1 Location updating initiation by the PP

Before initiating the location registration procedure the PP IWU shall compare the received ARI provided by the Lower Layer Management Entity (LLME) to the ARIs stored in the forbidden PLMNs list which are retrieved from the SIM/DAM GA. If the received ARI is equivalent to one of the ARIs in the forbidden PLMNs list, the location registration procedure shall not take place before a change of received ARI. The user can override this rule by manually initiating the location registration procedure. In this case, if the location registration is successful, the accessed PLMN shall be deleted from the forbidden PLMN list of the SIM/DAM GA:

- 1) upon change of the DECT location area the PP IWU retrieves the IMSI, TMSI, LAI, Kc and Cipher key number from the SIM/DAM GA. The DECT specific (non-GSM) part of <<LOCATION AREA>> and the <<FIXED IDENTITY >> information shall be retrieved from the active DECT subscription. After this the PP IWU issues a MM\_LOCATE-req primitive to the PT.

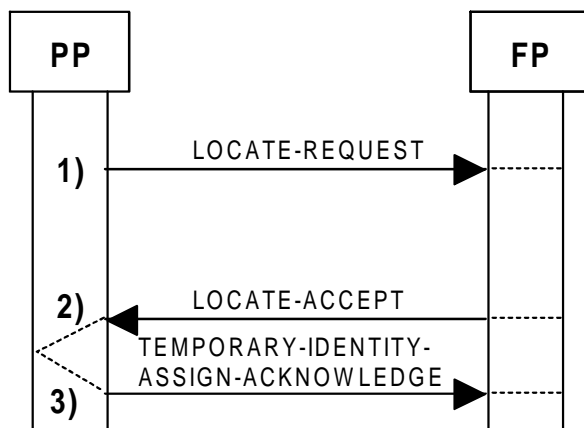

Figure 39: Location registration procedure

NOTE: Standard DECT rules for the inclusion of <Extended location information> field in the <<LOCATION-AREA>> information element are applied.

Upon receipt of the MM\_LOCATE-req primitive from the PP IWU the PT shall send a {LOCATE-REQUEST} message to the FT (figure 39) including the <<PORTABLE IDENTITY>>, <<FIXED IDENTITY>>, <<LOCATION AREA>>, <<NWK ASSIGNED IDENTITY>> and <<CIPHER INFO>> information elements provided by the PP IWU.

The field values of the <<LOCATION AREA>> information element shall be set as follows: the GSM LAI shall be sent in the <Extended location information> field.

The <<CIPHER KEY SEQUENCE NUMBER>> retrieved by the PP IWU from the SIM/DAM GA shall be sent transparently in the <Cipher key number> of the <<CIPHER INFO>> information element. <Proprietary algorithm identifier> field shall not be sent. <<CIPHER KEY SEQUENCE NUMBER>> field value shall be the one which has been received during the latest authentication procedure. The IMSI received from the PP IWU shall be sent in the <<PORTABLE IDENTITY>> Information element.

The field values in the <<Cipher info>> information element shall be set as shown in table 131.

Table 131: Field values for <<CIPHER INFO>>

Information element/Item number	Field	Value
<<CIPHER INFO>>		
3	MSB of the <Cipher key number>	"0"B
4	<Y/N bit>	"1" (Enable ciphering)
5	<Cipher algorithm identifier>	"0000001" (DECT standard cipher algorithm 1)
6	<Cipher key type>	"1001" (Derived cipher key)

The field values in the <<LOCATION AREA>> information element shall be set as shown in table 132.

Table 132: Field values for <<LOCATION AREA>>

Information element/Item number	Field	Value
<<LOCATION AREA>>		
1	<LI-type>	"11"B (LAL + extended location area information)
2	<ELI>	"1111"B (GSM location information)

The IMSI received from the PP IWU shall be sent in the <<PORTABLE IDENTITY>> Information element. The field values in the <<PORTABLE IDENTITY>> information element shall be set as shown in table 133;

Table 133: Field values for <<PORTABLE IDENTITY>>

Information element/Item number	Field	Value
<<PORTABLE IDENTITY>>		
1	<Identity type>	"0000000"B ("IPUI")
2	<PUT>	'0100'B (PUT for IPUI R)
PUT: Portable User Type		

- 2) upon receipt of a MM\_LOCATE-cfm primitive from the PT as a result of a {LOCATE-ACCEPT} message received by the PT the PP IWU shall replace the LAI value in the SIM/DAM GA with the received <Extended location information> field value of the <<LOCATION AREA>> information element and the existing TMSI in the SIM/DAM GA with the received <<NWK assigned id>> information element value if being received by the PT. The PP shall also reset the attempt counter and set the update status in the SIM/DAM GA to UPDATED;
- 3) if the <<NWK ASSIGNED IDENTITY>> has been received in the {LOCATE-ACCEPT} message the PT shall send a {TEMPORARY-IDENTITY-ASSIGN-ACK} message to the FT as defined in ETS 300 175-5 [5].

#### 6.3.2.3.5.2 Attempt counter

To limit the number of location updating attempts made, where location updating is unsuccessful, an attempt counter is used. It counts the number of consecutive unsuccessful location update attempts.

The attempt counter is incremented when a location update procedure fails. The specific situations are specified in subclause 6.3.2.3.5.3.

The attempt counter is reset when:

- the PP is powered on;
- a SIM/DAM GA is inserted;
- location update is successfully completed;
- location update completed with cause #76H, #80H or #81H;
- a new DECT location area is entered;
- on expiry of <MM loc\_upd.1> if this timer was started when the attempt counter reached its maximum value.

The attempt counter is used when deciding whether to re-attempt a location update after time-out of timer <MM loc\_upd.2>.

#### 6.3.2.3.5.3 Location updating not accepted by the network

Upon receipt of a {LOCATE-REJECT} message the PP IWU shall act as follows depending of the <<REJECT REASON>> value:

- a) "IPEI not accepted", "IPUI unknown" or "IPUI not accepted":
  - shall consider the SIM/DAM GA invalid until switch-off or the SIM/DAM GA is removed;
  - shall not initiate location updating;
- b) "PLMN not allowed":
  - shall store the current GSM operator code (GOP) value (contained in the ARI D) in the forbidden PLMNs list in the SIM/DAM GA;
  - shall not initiate location updating until the ARI broadcast by an FP has changed;
  - reset the attempt counter;
- c) "Location area not allowed"
  - shall not initiate location updating until the DECT location area has changed;
  - reset the attempt counter;
- d) "National roaming not allowed in this location area":
  - shall not initiate location updating until the DECT location area has changed;
  - memorize that during the next cell search, FP's with the same GOP should be excluded if possible;
  - reset the attempt counter.

In all cases a), b), c) and d) the PP IWU shall:

- delete the LAI, Cipher key, Cipher key number and TMSI as defined in annex B;
- set the update status to ROAMING NOT ALLOWED;
- not initiate detach procedure;
- not initiate outgoing calls except emergency calls.

The PP shall be capable of storing up to 4 entries in the forbidden PLMNs list.

In all other reject cases or situations of procedural failure the following behaviour should be implemented by the PP IWU:

- 1) increment the attempt counter;
- 2) depending on the DECT LA and the value of the attempt counter:

if the update status is UPDATED and the PP was last registered in the current DECT LA and the attempt counter is smaller than 4 then:

the PP shall start timer <MM loc\_upd.2>. When timer <MM loc\_upd.2> expires the location updating procedure is triggered again;

if the update status is different from UPDATED, or the PP was not last registered in the current DECT LA or the attempt counter is greater or equal to 4:

the PP shall delete any LAI, TMSI, ciphering key sequence number stored in the SIM/DAM GA and set the update status to NOT UPDATED. If the attempt counter is smaller than 4 the PP shall start timer <MM loc\_upd.2>, otherwise <MM loc\_upd.1> after the last active transaction is finished. When the started timer expires the location updating procedure is triggered again.

#### 6.3.2.4 Detach procedure

- 1) The PP IWU shall retrieve the IMSI from the SIM/DAM GA and issue a MM\_DETACH-req primitive to the PT. The PT shall send a {DETACH} message to the FT (figure 40). The {DETACH} message shall contain the IMSI in the <<PORTABLE IDENTITY>> information element and the TMSI in the <<NWK ASSIGNED IDENTITY>> information element.



Figure 40: Detach procedure

On removal of the SIM/DAM GA, the PT may send a {DETACH} message to the FT using the already retrieved subscription related data. All data related to the active subscription shall be deleted and ongoing transactions shall be aborted, using the abnormal call release as defined in subclause 6.1.1.6.

#### 6.3.2.5 Temporary identity assignment procedure

- 1) Upon receipt of a TEMPORARY\_IDENTITY\_ASSIGN-ind primitive from the PT the PP IWU shall replace the existing TMSI in the SIM/DAM GA with the received <<NWK ASSIGNED IDENTITY>> and the LAI in the SIM/DAM GA with the <Extended location area information> in the <<LOCATION AREA>> information element.
- 2) The PP IWU issues a TEMPORARY\_IDENTITY\_ASSIGN-res primitive to the PT. If the TEMPORARY\_IDENTITY\_ASSIGN-res primitive received by the PT indicates an accept, the PT shall attempt to assign a new TPUI value (if received). If this assignment is successful, or no TPUI value was received, the PT sends a {TEMPORARY-IDENTITY-ASSIGN-ACK} message to the FT (figure 41). If the TPUI assignment fails the PP shall send a {TEMPORARY-IDENTITY-ASSIGN-REJ}.

If the TEMPORARY\_IDENTITY\_ASSIGN-res primitive received by the PT indicates a reject, the PT shall not attempt to assign a new TPUI value and send a {TEMPORARY-IDENTITY-ASSIGN-REJ}.

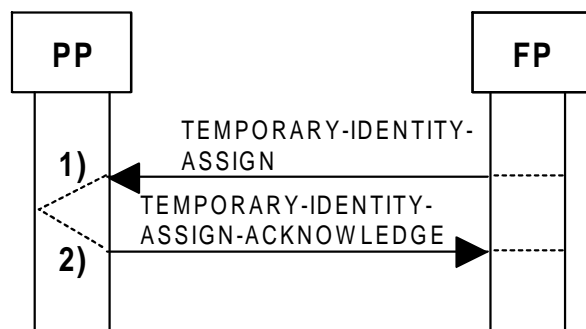

Figure 41: TMSI reallocation procedure

### 6.3.2.6 Cipherng related procedure

- 1) Upon receipt of a MM\_CIPHER-ind primitive from the PT as a result of a received {CIPHER-REQUEST} message from the FT (figure 42) the PP IWU shall check that there exists an associated cipher key Kc in the SIM/DAM GA as indicated in the <cipher key number> field in the <<CIPHER INFO>> information element. If the cipher key Kc exists the PP IWU shall retrieve the cipher key from the DAM and calculate the DECT cipher key as described in annex A.
- 2) After this the PP IWU sends a MM\_CIPHER-res primitive to the PT which initiates DECT standard cipherng.

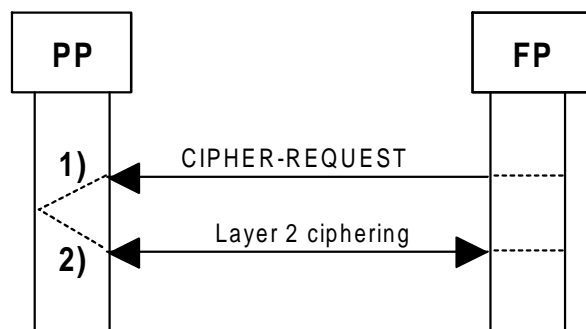

Figure 42: Cipherng procedure

PP IWU may reject the cipher request that reflecting in PT sending {CIPHER-REJECT} message to the FT. The possible reject reasons are described in ETS 300 175-7 [7]. FT behaviour is described in subclause 6.1.2.6.

### 6.3.2.7 External handover procedure

For a description of the external handover procedure, see subclause 6.1.2.9. PP specific behaviour is described in this subclause.

#### 6.3.2.7.1 Handover candidate procedure

The external handover candidate information is obtained using two sub-procedures, handover candidate indication and/or handover candidate retrieval as defined in ETS 300 175-5 [5], subclause 15.7.1.

Handover candidate retrieval, performed by the PT, shall be handled as defined in ETS 300 175-5 [5], subclause 15.7.1.3.

Target FP selection performed by the PP shall be handled as defined in ETS 300 175-5 [5].

#### **6.3.2.7.2 Handover reference retrieval**

When the PP determines that an external handover is required it shall initiate the handover reference retrieval procedures as defined in ETS 300 175-5 [5] with the following additions:

- the procedure is mandatory for every external handover, regardless if the "handover reference" was previously received or not;
- the PP shall indicate 'handover reference' in the <<info type>> information element within the {MM-INFO-REQUEST} message. This will trigger the FP-1 to initiate the Handover Required Indication to the MSC;
- the PP shall include the identities of its proposed external handover candidates in the <<fixed identity>> information element(s) within the {MM-INFO-REQUEST} message in order of preference.

In addition the PP shall only initiate one external handover reference retrieval procedure. The received 'network handover reference' shall be used by the PP for all transactions affected by the external handover.

#### **6.3.2.7.3 Handover execution by PP**

Successful handover resource allocation (see subclause 6.1.2.9.4) is indicated to the PP with a {MM-INFO-ACCEPT} message. The {MM-INFO-ACCEPT} message contains a 'network handover reference' to be used to correlate the reserved resources and also includes the chosen FP, identified by the <<FIXED IDENTITY>> information element.

#### **6.3.2.7.4 Handover request**

##### **6.3.2.7.4.1 Handover request to FP-2**

The PP shall initiate the layer 3 setup procedure, based on the target cell provided in {MM-INFO-ACCEPT} message by sending the {CC-SETUP} message to the handover candidate FP-2 indicating in the <<BASIC SERVICE>> information element <Call class> field the external handover call setup. The PP shall also include the 'network handover reference' in the <<NETWORK PARAMETER>> information element as received from the FP-1.

During handover request to FP-2 and also during all subsequent messages until all transactions have been released, the PP shall use a Transaction Identifier that contains an Extended Transaction Value (TVX). See subclause 6.3.2.7.8 for detailed information related to this ETS on specific handling of transaction identifiers during external handover.

##### **6.3.2.7.4.2 Handover accept by PP**

When the network has indicated confirmation of handover, the PP shall send a {CC-CONNECT-ACK} message to the FP-2 to indicate to the network that the PP accepts the handover.

Since the DECT external handover is performed on an individual transaction basis, compared to GSM where the handover is performed on a radio connection level, the PP shall not send any {CC-CONNECT-ACK} message until all transactions affected by the external handover have been accepted.

#### 6.3.2.7.4.3 Cipherring procedure

Cipherring shall be initiated by the PP as soon as possible after receipt of the {CC-CONNECT} message, prior to returning the {CC-CONNECT-ACK} message. The cipherring procedure for external handover shall be initiated by the PP as defined in the DECT base standard ETS 300 175-5 [5] subclause 15.7.6. In addition the following shall apply:

- cipherring mode shall not be changed during external handover;
- ciphersed/unciphersed information shall not be sent on parallel legs during handover;
- cipherring shall be re-established on old leg if handover failed.

PP shall indicate failed cipherring to FP-1 by sending a {MM-INFO-REQUEST} message indicating "handover failed, reversion to old channel" to be able to restore old network connections.

#### 6.3.2.7.5 Release of old connection

The external handover is completed with the release of the old connection. The release procedure is defined in ETS 300 175-5 [5] subclause 15.7.4.5.

#### 6.3.2.7.6 Handover reject

A precondition for external handover is that the PP is state T-10, the 'active state'. If not, the external handover shall not be initiated.

PP may decide to not complete the initiated handover attempt e.g. due to changed radio conditions. For these cases, if the handover attempt is aborted/rejected, it is the responsibility of the PP to inform the FP-1 about the new situation so that reserved network resources can be released, and the original connection restored.

If an external handover is initiated and not yet completed and the PP has decided that it will not complete the handover it shall send a {MM-INFO-REQUEST} message to the FP-1 indicating "handover failed, reversion to old channel" in the <<info type>> information element. The FP will return a {MM-INFO-ACCEPT} message as a confirmation.

NOTE: PP shall await response of already initiated {MM-INFO-REQUEST} before initiating another {MM-INFO-REQUEST}.

The PP may reject the handover after reception of the {CC-CONNECT} from the FP-2. The PP shall in addition to above then release the new link by sending {CC-RELEASE} to the FP-2, who will return {CC-RELEASE-COM} to the PP.

#### 6.3.2.7.7 Support of external handover due to O&M activities

In GSM it is possible to initiate a handover for internal O&M reason, e.g. during replacement of hardware. The support for this functionality in DECT/GSM Interworking is provided by utilizing the existing procedures defined in ETS 300 175-5 [5] as follows:

- upon receipt of a {MM-INFO-SUGGEST} message, without previously requested external handover, the PP may initiate a NWK layer set up procedure as defined in subclause 15.7.4 of ETS 300 175-5 [5].



### 6.3.2.7.8 Handling of transaction identifiers during and after external handover

During Handover Request to FP-2 and all the subsequent messages, special handling of the Transaction Identifiers is required since it is required to use the original transaction identifier towards the GSM network. This is also required during and after an external handover has been executed.

After the completion of an external handover, Extended Transaction Identifiers (ETI) will be used on the new PP - FP-2 connection, as defined in table 134 below. Extended Transaction Identifiers shall be used for all subsequent messages used on the new connection.

The Extended Transaction Identifier shall be structured as defined subclause 7.3 of the ETS 300 175-5 [5], in addition the unique coding of this ETS and usage of the Extended Transaction Value (TVX) shall be supported as defined in this subclause. This shall be supported by both PP and FP during and after execution of external handover.

The Transaction value (TV) shall indicate 'TV extension' and the Extended Transaction Value (TVX) shall consist of a Original Transaction Value (OTV), Original Transaction Flag (OTF), and a Function Group Identifier (FGI) as defined in table 134 below.

**Table 134: Definition of Extended Transaction Identifier (ETI) used during and after external handover**

Field	Description
Transaction Identifier (TI)	Transaction Identifier, see subclause 6.1.8.1.2 and ETS 300 175-5 [5], subclause 7.3
Extended Transaction Identifier (ETI)	Transaction Identifier (TI) where an additional octet is used containing an 8-bit Extended Transaction Value (TVX), see below and ETS 300 175-5 [5], subclause 7.3
Flag (F)	Indicating Transaction originator See ETS 300 175-5 [5], subclause 7.3
Transaction Value (TV)	Transaction Value, see ETS 300 175-5 [5], subclause 7.3
Extended Transaction Value (TVX)	Extended Transaction value when Transaction Value coded to 'TV Extension' (111). See below and ETS 300 175-5 [5], subclause 7.3
Function Group Identifier (FGI)	Identifier of original transaction type, see below.
Original Transaction Flag (OTF)	Indicating Transaction Flag (F) value for original call, prior to first external handover, see below.
Original Transaction Value (OTV)	Transaction Value used prior to first external handover. Shall be identical to the Transaction Value (TV) used prior to external handover, see also below.

PP and FP shall support transparent mapping of Transaction Value (TV) and Transaction Flag (F) or Original Transaction Value (OTV) and Original Transaction Flag (OTF) respectively, thereby allowing for a transparent handling of Transaction Identifiers.

The structure of the Extended Transaction Identifier (ETI) as defined in table 135 shall be supported.

**Table 135**

8	7	6	5	4	3	2	1	Octet
Flag (F)		Transaction Value (TV) = TV Extension (1 1 1)			Protocol Discriminator (PD) (See subclause 6.1.8.1.1)			1
Extended Transaction Value (TVX)								1a

The detailed coding of the Extended Transaction Value (TVX) as defined in table 136 shall be used.

Table 136

8	7	6	5	4	3	2	1	Octet
Function Group Identifier (FGI)			spare	(OTF)	Original Transaction Value (OTV)			1a

**Function Group Identifier (FGI):**

Bits:	8	7	6	Meaning
	0	0	0	CC Transaction
	0	0	1	SMS Transaction
	0	1	0	SS Transaction
	0	1	1	} Reserved
		to	}	
	1	1	1	}

**Original Transaction Flag (OTF):**

Same coding as for Transaction Flag (F), see ETS 300 175-5 [5], subclause 7.3

**Original Transaction Value (OTV):**

Same coding as for Transaction Value (TV), see ETS 300 175-5 [5], subclause 7.3

**6.3.3 Paging related IWU procedure**

- 1) Upon receipt of a {LCE-REQUEST-PAGE} message from the FT the PT shall send a {LCE-PAGE-RESPONSE} message with the following information elements: <<PORTABLE IDENTITY>>, <<CIPHER INFO>> and <<NWK ASSIGNED IDENTITY>> retrieved from the SIM/DAM GA. The <Cipher key number> field value shall be the one which has been received during the latest authentication procedure and stored in the SIM/DAM GA.

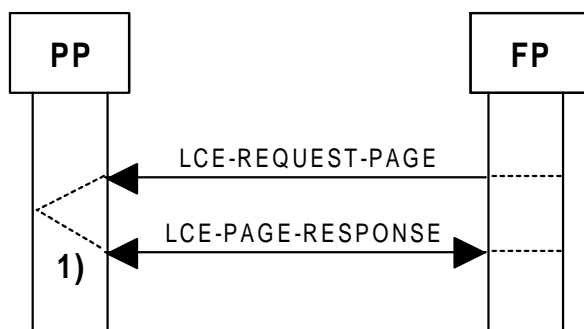

Figure 43: Paging procedure

The fields in the <<CIPHER INFO>> information element shall be set as shown in table 137.

**Table 137: Field values for <<Cipher info>>**

Information element/Item number	Field	Value
<b>&lt;&lt;CIPHER INFO&gt;&gt;</b>		
1	MSB of the <Cipher key number>	"0"B
2	<Y/N bit>	"1" (Enable ciphering)
3	<Cipher algorithm identifier>	"0000001" (DECT standard cipher algorithm 1)
4	<Cipher key type>	"1001" (Derived cipher key)

#### 6.3.4 Message mappings

No message mappings applied.

#### 6.3.5 Information element mappings

These are the only information elements that are required to be mapped to the SIM/DAM GA. Other possible local application between PT and SIM/DAM GA are out of the scope of this ETS.

**Table 138: Mapping of DECT air interface fields/information elements to the DAM EFs**

DECT Information element/field, Identity	SIM/DAM GA Element	Elementary File (EF)
<<PORTABLE IDENTITY>> (IPUI type R)	IMSI	EF IMSI
<<NWK ASSIGNED IDENTITY>>	Temporary Mobile Subscriber Identity	EF LOCI
<Extended location area information> field in <<LOCATION AREA>> information element	Location Area identification	EF LOCI
<Cipher key number> field in <<CIPHER INFO>> information element	Cipher key sequence number	EF Kc
-	Cipher key Kc	EF Kc
GOP value	PLMN (forbidden)	EF FPLMN

#### 6.3.6 Stopping of CC timers

Upon receipt of a << TIMER RESTART>> information element in a {CC-NOTIFY} message from the FP IWU the PP shall act as follows:

- 1) If the Restart value coding indicates 'restart timer', the PP shall proceed according to GAP.
- 2) If the Restart value coding indicates 'stop timer' and the {CC-NOTIFY} message was received during establishment or release of a call the PP shall stop all CC timers related to that call.

## 7 Interworking connection type definitions

There is only one DECT connection type defined in this ETS. This is equivalent to the GAP basic service for DECT air interface requirements.

The DECT C-Plane and U-Plane attributes are described as the default set-up attributes in the <<BASIC SERVICE>> element defined as "GSM Profile phase 2".

**Table 139: Default coding for GSM profile phase 2 <<IWU-ATTRIBUTES>> information element**

	Information element field	Field value
3	Coding standard Information transfer cap.	DECT standard Speech
4	Negotiation indicator External connection type	Not possible Connection oriented
5	Transfer mode Info. transfer rate	Circuit mode 32 kbits/s
6	Protocol identifier User protocol id	User protocol id G.721 ADPCM

**Table 140: Default coding for GSM profile phase 2 <<CALL-ATTRIBUTES>> information element**

Octet	Information element field	Field value
3	Coding standard Network layer attributes	DECT standard GSM Profile Phase 2 = "00100"B
4	C-Plane class C-Plane routing	Class A; shared Cs only
5	U-Plane symmetry LU identification	Symmetric LU1
6	U-Plane class U-Plane frame type	Class 0 min_delay FU1

## **Annex A (normative): Derivation of the DECT ciphering key CK**

### **A.1 Introduction**

This annex defines the method of deriving the DECT ciphering key CK from the GSM ciphering key Kc in the case the length of CK differs from the Kc. If the keys are equivalent in length the GSM Kc shall be mapped transparently to the DECT CK.

### **A.2 Algorithm to calculate the DECT CK from Kc**

The Kc with  $L1 > N$  bits can be mapped into a CK with N bits by taking the lower N bits of Kc. A key Kc with  $L2 < N$  bits can be mapped into a CK with N bits by using:

$$CK(i) = Kc(i \text{ modulo } L2), 0 \leq i \leq N - 1.$$

## Annex B (normative): Deletion of the GSM Kc, CKSN, TMSI and LAI

When explicitly stated in this ETS the PP IWU shall delete Elementary Files (EFs) in the DAM GSM Application (SIM/DAM GA) associated to the Location Area Identification (LAI) and Temporary Mobile Subscriber Identity (TMSI) by filling the EFs with binary "1"s. The Cipherng Key (Kc) and the Cipherng Key Sequence Number (CKSN) are both deleted implicitly by filling the associated EF to the CKSN with binary "1"s.

The PP IWU shall never explicitly examine the contents of these EF when retrieving/passing information from/to the SIM/DAM GA i.e. the FP IWU shall always process the information as required by the associated procedure (as an exception to normal action in a GSM Mobile Station) and the examination of the information contents shall be done in the FP IWU (if deleted or not). See table B.1.

NOTE: The FP may implicitly delete the wanted EFs by sending binary "1"s in the associated DECT information elements.

**Table B.1: Associated information elements of DECT and GSM**

DECT	GSM	Invalid/deleted value
<<NWK ASSIGNED IDENTITY>>	TMSI	"11111111111111111111111111111111" B (32 bits)
<Extended location information> in <<LOCATION AREA>>	LAI	"1111111111111111" B (16 bits)
<Cipher key number> in <<CIPHER KEY>>	CKSN	"1111" B

## **Annex C (normative): Mapping of equipment identities**

Each PP has a unique identity and shall transmit this to the FP on request. All IMEI enquiry procedures (IPEI) shall be supported by the PP as specified in ETS 300 508 [17] (GSM 02.16).

The following procedure shall instruct the PP to display its IPEI: \*#06#

The procedure shall be accepted and performed with and without an inserted SIM/DAM GA.

### **Support of GSM Mobile Equipment Identity (IMEI), Phase 1**

The GSM phase 1 IMEI is coded in 15 digits with a spare digit in the end. The FP shall map the IPEI received from the PP to the GSM IMEI as described in ETS 300 523 [34] (GSM 03.03) according to the following principle:

- in order to identify an IMEI as DECT specific, the two most significant digits of the TAC in the IMEI shall be "00";
- the decimal value of the EMC shall be mapped to the 4 remaining digits of the TAC and the first digit of the FAC;
- the decimal value of the PSN shall be mapped to the remaining digit of the FAC and to the 6 digits of the SNR.

### **Support of GSM Mobile Equipment Identity and Software Version Number (IMEISV), Phase 2**

The GSM phase 2 IMEISV is coded in 16 digits where the last two digits indicate software revision number (SV = 2 digits software version number / software revision number). The FP shall map the IPEI and Model identifier received from the PP to the GSM IMEISV as described in ETS 300 523 [34] (GSM 03.03) according to the following principle:

- in order to identify an IMEISV as DECT specific, the two most significant digits of the TAC in the IMEISV shall be "00";
- the decimal value of the EMC shall be mapped to the 4 remaining digits of the TAC and the first digit of the FAC;
- the decimal value of the PSN shall be mapped to the remaining digit of the FAC and to the 6 digits of the SNR;
- the DECT FP shall interpret the Model identifier during location registration. The decimal value of the lowest 6 bits of the <MODIC> field in the <<MODEL IDENTIFIER>> information element shall be mapped to the 2 digits of the SVN. The EMC mapped shall be set according to the EMC value of the IPEI.

NOTE: The mapping of Model identifier to the SVN supports 64 (0 - 63) different version numbers of PP software.

## Annex D (informative): Physical attachment models for the FP

### D.1 Introduction

This annex lists some alternative physical models for different FP attachments for the GSM PLMN.

### D.2 Physical attachment to the MSC

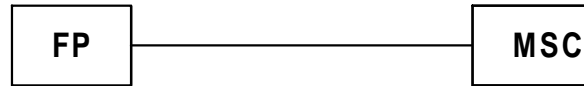

Figure D.1: FP MSC attachment

### D.3 Physical attachment to the BSC

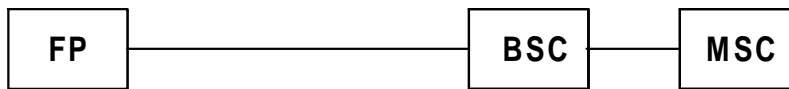

Figure D.2: FP BSC attachment

### D.4 Physical attachment to the BTS

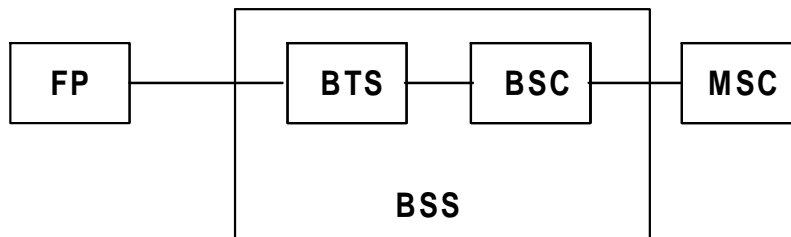

Figure D.3: FP BTS attachment



## **Annex E (informative): Bibliography**

The following references are given for informative purposes within this ETS.

- CCITT Recommendation Q.6xx series: "Interworking of signalling systems".

## History

Document history	
July 1995	First Edition
August 1996	Public Enquiry PE 112: 1996-08-19 to 1996-12-13