



EUROPEAN
TELECOMMUNICATION
STANDARD

ETS 300 369-1

May 1995

Source: ETSI TC-SPS

Reference: T/S 46-33Q1

ICS: 33.080

Key words: ISDN, supplementary service

**Integrated Services Digital Network (ISDN);
Explicit Call Transfer (ECT) supplementary service
Digital Subscriber Signalling System No. one (DSS1) protocol
Part 1: Protocol specification**

ETSI

European Telecommunications Standards Institute

ETSI Secretariat

Postal address: F-06921 Sophia Antipolis CEDEX - FRANCE

Office address: 650 Route des Lucioles - Sophia Antipolis - Valbonne - FRANCE

X.400: c=fr, a=atlas, p=etsi, s=secretariat - **Internet:** secretariat@etsi.fr

Tel.: +33 92 94 42 00 - Fax: +33 93 65 47 16

Copyright Notification: No part may be reproduced except as authorized by written permission. The copyright and the foregoing restriction extend to reproduction in all media.

© European Telecommunications Standards Institute 1995. All rights reserved.

Contents

Foreword	5
1 Scope	7
2 Normative references	7
3 Definitions	8
4 Abbreviations	9
5 Description	10
6 Operational requirements	10
6.1 Provision and withdrawal	10
6.2 Requirements on the originating network side	10
6.3 Requirements on the destination network side	10
7 Coding requirements	10
7.1 Coding of the Facility information element components	10
7.2 Coding of the Notification indicator information element	12
7.3 Coding of the Redirection number information element	12
8 State definitions	12
9 Signalling procedures at the coincident S and T reference point	13
9.1 Activation, deactivation and registration	13
9.2 Invocation and operation	13
9.2.1 Explicit call transfer request using implicit linkage procedures	13
9.2.1.1 Normal operation	13
9.2.1.2 Exceptional procedures	13
9.2.2 Explicit call transfer request using explicit linkage procedures	14
9.2.2.1 Requesting a LinkId value	14
9.2.2.1.1 Normal operation	14
9.2.2.1.2 Exceptional procedures	14
9.2.2.2 Requesting call transfer	15
9.2.2.2.1 Normal operation	15
9.2.2.2.2 Exceptional procedures	15
9.2.3 Confirmation of call transfer	16
9.2.3.1 Normal operation	16
9.2.3.2 Exceptional procedures	16
9.2.4 Procedures for remote users when both calls to the users are in the Active call state	16
9.2.4.1 Normal operation	16
9.2.4.2 Exceptional procedures	17
9.2.5 Procedures for remote users with one of the calls to the users in the Call Delivered call state (network option)	17
9.2.5.1 Normal operation	17
9.2.5.2 Exceptional procedures	17
9.3 Content of notification information	18
10 Procedures for interworking with private ISDNs	21
10.1 Served user is connected to the private ISDN	21
10.1.1 Normal operation	21
10.1.2 Exceptional procedures	22

10.2	Remote user is connected to the private ISDN	22
10.2.1	Normal operation	22
10.2.2	Exceptional procedures	23
10.3	Procedures for the mechanism to avoid looping of uncontrolled circuits	23
10.3.1	Procedures at the served network side	23
10.3.1.1	Normal operation	23
10.3.1.2	Exceptional procedures	24
10.3.2	Procedures at the remote network side	24
10.3.2.1	Normal operation	24
10.3.2.2	Exceptional procedures	24
11	Interactions with other networks	24
12	Interaction with other supplementary services	25
13	Parameter values (timers)	25
14	Dynamic description	25
14.1	User side SDL diagrams	25
14.2	Network side SDL diagrams	30
Annex A (informative):	Signalling flows	33
Annex B (informative):	Assignment of object identifier values	42
History		43

Foreword

This European Telecommunication Standard (ETS) has been produced by the Signalling Protocols and Switching (SPS) Technical Committee of the European Telecommunications Standard Institute (ETSI).

This ETS is part 1 of a multi-part standard covering the Digital Subscriber Signalling System No. one (DSS1) protocol specification for the Integrated Services Digital Network (ISDN) diversion supplementary services, as described below:

Part 1: "Protocol specification";

Part 2: "Protocol Implementation Conformance Statement (PICS) proforma";

Part 3: "Test Suite Structure and Test Purposes (TSS&TP) for the user";

Part 4: "Abstract Test Suite (ATS) and partial Protocol Implementation eXtra Information for Testing (PIXIT) proforma for the user";

Part 5: "TSS&TP for the network";

Part 6: "ATS and partial PIXIT proforma for the network".

In accordance with CCITT Recommendation I.130, the following three level structure is used to describe the supplementary telecommunication services as provided by European public telecommunications operators under the pan-European ISDN:

- Stage 1: is an overall service description, from the user's standpoint;
- Stage 2: identifies the functional capabilities and information flows needed to support the service described in stage 1; and
- Stage 3: defines the signalling system protocols and switching functions needed to implement the service described in stage 1.

This ETS details the stage 3 aspects (signalling system protocols and switching functions) needed to support the Explicit Call Transfer (ECT) supplementary service. The stage 1 and stage 2 aspects are detailed in ETS 300 367 (1995) and ETS 300 368 (1995), respectively.

Transposition dates	
Date of latest announcement of this ETS (doa):	31 August 1995
Date of latest publication of new National Standard or endorsement of this ETS (dop/e):	29 February 1996
Date of withdrawal of any conflicting National Standard (dow):	29 February 1996

Blank page

1 Scope

This first part of ETS 300 369 specifies the stage three of the Explicit Call Transfer (ECT) supplementary service for the pan-European Integrated Services Digital Network (ISDN) as provided by European public telecommunications operators at the T reference point or coincident S and T reference point (as defined in ITU-T Recommendation I.411 [5]) by means of the Digital Subscriber Signalling System No. one (DSS1) protocol. Stage three identifies the protocol procedures and switching functions needed to support a telecommunication service (see CCITT Recommendation I.130 [3]).

In addition, this ETS specifies the protocol requirements at the T reference point where the service is provided to the user via an intermediate private ISDN.

This ETS does not specify the additional protocol requirements where the service is provided to the user via a telecommunications network that is not an ISDN.

The ECT supplementary service enables a user who has two calls, each of which can be an incoming call or an outgoing call, to connect together the other users in the two calls, into one call. One of the two calls shall be answered, the other call can be either answered or, as a network option, in the alerting phase.

The ECT supplementary service is applicable to all circuit-switched basic telecommunication services using one B-channel.

Further parts of ETS 300 369 specify the method of testing required to identify conformance to this ETS.

This ETS is applicable to equipment supporting ECT supplementary service, to be attached at either side of a T reference point or coincident S and T reference point when used as an access to the public ISDN.

2 Normative references

This ETS incorporates by dated or undated reference, provisions from other publications. These normative references are cited at the appropriate places in the text and the publications are listed hereafter. For dated references, subsequent amendments to or revisions of any of these publications apply to this ETS only when incorporated in it by amendment or revision. For undated references the latest edition of the publication referred to applies.

- [1] CCITT Recommendation E.164 (1991): "Numbering plan for the ISDN era".
- [2] ITU-T Recommendation I.112 (1993): "Vocabulary of terms for ISDNs".
- [3] CCITT Recommendation I.130 (1988): "Method for the characterization of telecommunication services supported by an ISDN and network capabilities of an ISDN".
- [4] ITU-T Recommendation I.210 (1993): "Principles of telecommunication services supported by an ISDN and the means to describe them".
- [5] ITU-T Recommendation I.411 (1993): "ISDN user-network interfaces -reference configurations".
- [6] CCITT Recommendation X.208 (1988): "Specification of Abstract Syntax Notation One (ASN.1)".
- [7] CCITT Recommendation X.219 (1988): "Remote operations: Model, notation and service definitions".
- [8] CCITT Recommendation Z.100 (1988): "Specification and Description Language (SDL)".

- [9] ETS 300 092-1 (1992) including amendment A2 (1994): "Integrated Services Digital Network (ISDN); Calling Line Identification Presentation (CLIP) supplementary service; Digital Subscriber Signalling System No. one (DSS1) protocol; Part 1: Protocol specification".
- [10] ETS 300 097-1 (1992) including amendment A1 (1994): "Integrated Services Digital Network (ISDN); Connected Line Identification Presentation (COLP) supplementary service; Digital Subscriber Signalling System No. one (DSS1) protocol; Part 1: Protocol specification".
- [11] ETS 300 102-1 (1990) including amendment A2 (1993): "Integrated Services Digital Network (ISDN); User-network interface layer 3; Specifications for basic call control".
- [12] ETS 300 102-2 (1990): "Integrated Services Digital Network (ISDN); User-network interface layer 3 specifications for basic call control; SDL diagrams".
- [13] ETS 300 141-1 (1992): "Integrated Services Digital Network (ISDN); Call Hold (HOLD) supplementary service; Digital Subscriber Signalling System No. one (DSS1) protocol; Part 1: Protocol specification".
- [14] ETS 300 195-1 (1995): "Integrated Services Digital Network (ISDN); Supplementary service interactions; Digital Subscriber Signalling System No. one (DSS1) protocol; Part 1: Protocol specification".
- [15] ETS 300 196-1 (1993): "Integrated Services Digital Network (ISDN); Generic functional protocol for the support of supplementary services; Digital Subscriber Signalling System No. one (DSS1) protocol; Part 1: Protocol specification".
- [16] ETS 300 207-1 (1994): "Integrated Services Digital Network (ISDN); Diversion supplementary services; Digital Subscriber Signalling System No. one (DSS1) protocol; Part 1: Protocol specification".
- [17] ETS 300 367 (1995): "Integrated Services Digital Network (ISDN); Explicit Call Transfer (ECT) supplementary service; Service description".
- [18] ETS 300 402-1: "Integrated Services Digital Network (ISDN); Digital Subscriber Signalling System No. one (DSS1); User-network interface data link layer; Part 1: General aspects [ITU-T Recommendation Q.920 (1993), modified]".

3 Definitions

For the purposes of this ETS, the following definitions apply:

call A-C: The call between user A and user C.

call A-B: The call between user A and user B.

call state: A state as defined in ETS 300 102-1 [11], subclause 2.1 for either the user side or the network side as appropriate. A call state may exist for each call reference value (and for each additional responding CEI in the incoming call state).

component: See ETS 300 196-1 [15], subclause 8.2.2.

Connection Endpoint Identifier (CEI): See subclause 3.4.1 of ITU-T Recommendation Q.920 as modified by ETS 300 402-1 [18].

Integrated Services Digital Network (ISDN): See ITU-T Recommendation I.112 [2], definition 308.

invoke component: See ETS 300 196-1 [15], subclause 8.2.2.1. Where reference is made to a "xxxx" invoke component, an invoke component is meant with its operation value set to the value of the operation "xxxx".

ISDN number: A number conforming to the numbering plan and structure specified in CCITT Recommendation E.164 [1].

network: The DSS1 protocol entity at the network side of the user-network interface.

network A: The network to which the served user is attached.

network B: The network to which user B is attached.

network C: The network to which user C is attached.

public network: The DSS1 protocol entity at the network side of the user-network interface at the T reference point.

private network: The DSS1 protocol entity at the user side of the user-network interface at the T reference point.

reject component: See ETS 300 196-1 [15], subclause 8.2.2.4.

return error component: See ETS 300 196-1 [15], subclause 8.2.2.3. Where reference is made to a "xxxx" return error component, a return error invoke component is meant with its operation value set to the value of the operation "xxxx".

return result component: See ETS 300 196-1 [15], subclause 8.2.2.2. Where reference is made to a "xxxx" return result component, a return result component is meant with its operation value set to the value of the operation "xxxx".

served user; user A: The served user is the user who invokes the ECT supplementary service.

service; telecommunication service: See ITU-T Recommendation I.112 [2], definition 201.

supplementary service: See ITU-T Recommendation I.210 [4], subclause 2.4.

user: The DSS1 protocol entity at the user side of the user-network interface.

user B: The other user in one of user A's calls. By convention, in this standard, it is considered that the connection has been established on this call.

user C: The other user in another of user A's calls.

NOTE: In this context, the sequence of the call setups is of no consequence, i.e. call A-C may exist before the call A-B.

4 Abbreviations

For the purposes of this ETS, the following abbreviations apply:

CEI	Connection Endpoint Identifier
CLIR	Calling Line Identification Restriction
COLR	Connected Line Identification Restriction
DSS1	Digital Subscriber Signalling System No. one
ECT	Explicit Call Transfer
ISDN	Integrated Services Digital Network
NIE	Notification indicator Information Element
RDNIE	Redirection Number Information Element

5 Description

The ECT supplementary service enables a user (user A) who has two calls, each of which can be an incoming call or an outgoing call, to connect together the other users in the two calls, into one call. One of the two calls shall be answered, the other call can be either answered or, as a network option, in the alerting phase. The two calls shall be controlled using the same data link connection identified by the same CEI value.

When the ECT supplementary service is invoked, the served user shall send a message to the network, identifying the users to be connected. The network responds by releasing both calls at user A and establishing a connection between user B and user C, and at the same time sending a notification of the transfer to both users B and C. See also ETS 300 367 [17], clause 5.

The procedures are currently restricted to basic telecommunication services involving a single 64 kbit/s connection. This standard is not applicable to a video telephony call involving two 64 kbit/s connections.

6 Operational requirements

6.1 Provision and withdrawal

The ECT supplementary service is provided by prior arrangements with the service provider.

Withdrawal of the service is made by the service provider upon request by the subscriber or for service provider reasons.

6.2 Requirements on the originating network side

The originating network (served user side) shall provide the Call Hold supplementary service ETS 300 141-1 [13] in connection with the ECT supplementary service and shall be capable of sending notifications related to the ECT supplementary service to the destination network sides. In the case where the network supports the option allowing the transfer of an alerting call, the other user shall be notified when the alerting call is answered.

6.3 Requirements on the destination network side

The destination network (remote user sides) shall be able to:

- receive an indication of the transfer from the originating network and convey notification of the transfer, and a request for subaddress to the user who remains part of the transferred call;
- receive a subaddress from the remote user and convey it to the network of the other remote user;
- receive a subaddress from the network of the other remote user and convey it to the user.

7 Coding requirements

7.1 Coding of the Facility information element components

Table 1 shows the definition of the operations and errors required for the ECT supplementary service using Abstract Syntax Notation one (ASN.1) as defined in CCITT Recommendation X.208 [6] and using the OPERATION and ERROR macro as defined in CCITT Recommendation X.219 [7], figure 4/X.219.

The formal definition of the component types to encode these operations and errors is provided in ETS 300 196-1 [15], annex D, clause D.1. The inclusion of components in Facility information elements is defined in ETS 300 196-1 [15], subclause 11.2.2.1.

All components (invoke, return result, return error and reject) shall be included within a Facility information element. This Facility information element may be included in any appropriate message as specified in ETS 300 196-1 [15], subclause 8.3.1.1, unless a more restrictive specification is given in clause 9.

Table 1: Operation and error definitions for the ECT supplementary service

```

Explicit-Call-Transfer-Operations-and-Errors {ccitt identified-organization etsi(0) 369
operations-and-errors(1)}

DEFINITIONS ::=
BEGIN
EXPORTS
    EctLinkIdRequest,
    EctExecute,
    RequestSubaddress,
    SubaddressTransfer,
    ExplicitEctExecute,
    LinkIdNotAssignedByNetwork,
    EctLoopTest,
    EctInform;
IMPORTS
    OPERATION,
    ERROR
    FROM Remote-Operation-Notation
        {joint-iso-ccitt remote-operations(4) notation(0)}

    notAvailable,
    notSubscribed,
    resourceUnavailable,
    supplementaryServiceInteractionNotAllowed,
    invalidCallState
    FROM General-Errors
        {ccitt identified-organization etsi(0) 196 general-errors(2)}

    PartySubaddress,
    PresentedNumberUnscreened
    FROM Addressing-Data-Elements
        {ccitt identified-organization etsi(0) 196 addressing-data-elements(6)};

EctExecute ::= OPERATION
    RESULT
    ERRORS {notAvailable,
            notSubscribed,
            invalidCallState,
            supplementaryServiceInteractionNotAllowed}

EctInform ::= OPERATION
    ARGUMENT SEQUENCE {
        ENUMERATED {
            alerting (0),
            active (1)},
        redirectionNumber PresentedNumberUnscreened OPTIONAL}

EctLinkIdRequest ::= OPERATION
    RESULT LinkId
    ERRORS {resourceUnavailable}

EctLoopTest ::= OPERATION
    ARGUMENT CallTransferIdentity
    RESULT LoopResult
    ERRORS {notAvailable}

ExplicitEctExecute ::= OPERATION
    ARGUMENT LinkId
    RESULT
    ERRORS {notAvailable,
            notSubscribed,
            invalidCallState,
            supplementaryServiceInteractionNotAllowed,
            LinkIdNotAssignedByNetwork}

RequestSubaddress ::= OPERATION

SubaddressTransfer ::= OPERATION
    ARGUMENT transferredToSubaddress PartySubaddress

CallTransferIdentity ::= INTEGER (-128..127)
LinkId ::= INTEGER (1..127)
LoopResult ::= ENUMERATED {
    insufficientInformation (0),
    noLoopExists (1),
    simultaneousTransfer (2)}

LinkIdNotAssignedByNetwork ::= ERROR

eCTOID OBJECT IDENTIFIER ::= {ccitt identified-organization etsi(0) 369
operations-and-errors(1)}

ectExecute EctExecute ::= localValue 6

```

Table 1 (concluded): Operation and error definitions for the ECT supplementary service

explicitEctExecute	ExplicitEctExecute	::= globalValue	{eCTOID explicitEctExecute-operation(1)}
requestSubaddress	RequestSubaddress	::= globalValue	{eCTOID requestSubaddress-operation(2)}
subaddressTransfer	SubaddressTransfer	::= globalValue	{eCTOID subaddressTransfer-operation(3)}
ectLinkIdRequest	EctLinkIdRequest	::= globalValue	{eCTOID ectLinkIdRequest-operation(4)}
ectInform	EctInform	::= globalValue	{eCTOID ectInform-operation(5)}
ectLoopTest	EctLoopTest	::= globalValue	{eCTOID ectLoopTest-operation(6)}
linkIdNotAssignedByNetwork	LinkIdNotAssignedByNetwork	::= globalValue	{eCTOID linkIdNotAssignedByNetwork-error(21)}
END -- Explicit-Call-Transfer-Operations-and-Errors			

7.2 Coding of the Notification indicator information element

For the coding of the Notification indicator Information Element (NIE), see ETS 300 102-1 [11], subclause 4.5.21.

For the ECT supplementary service, the notification description (octet 3) of the Notification indicator information element shall be coded "call transferred, active" or "call transferred, alerting". The coding is shown in table 2.

Table 2: Notification description

Bits							
7	6	5	4	3	2	1	
1	1	0	1	0	0	1	Call transferred, alerting
1	1	0	1	0	1	0	Call transferred, active

7.3 Coding of the Redirection number information element

The purpose of the Redirection Number Information Element (RDNIE) is to identify the ISDN number of the transferred user. The coding of the Redirection number information element shall be as defined in ETS 300 207-1 [16], subclause 7.2.3.

8 State definitions

The call states as specified in ETS 300 102-1 [11], subclause 2.1 shall apply. The auxiliary states as specified in ETS 300 196-1 [15], subclause 7.1.2 shall apply. For the associated use of the Call Hold supplementary service, the auxiliary states are defined in ETS 300 141-1 [13].

Table 3 defines the states for the ECT supplementary service.

Table 3: States for user A and network A associated to the ECT supplementary service

User A states	
ECT Idle	An instance of the ECT supplementary service has not been requested.
ECT LinkId Request	A request for a link identifier has been initiated.
ECT LinkId Assigned	A LinkId value is assigned.
Await ECT LinkId	A LinkId value has not yet been assigned.
ECT Implicit Request	The ECT supplementary service has been requested using the implicit linkage procedure, confirmation is awaited.
ECT Explicit Request	The ECT supplementary service has been requested using the explicit linkage procedure, confirmation is awaited.
Network A state	
ECT Idle	An instance of the ECT supplementary service has not been requested.

9 Signalling procedures at the coincident S and T reference point

9.1 Activation, deactivation and registration

Not applicable.

9.2 Invocation and operation

To perform an explicit call transfer, the states at user A shall be one of the combinations indicated in table 4.

Table 4: States at user A for the invocation of the ECT supplementary service

Call A↔B	Call A↔C	Examples of signalling flow for information
(Active call state, Call Held auxiliary state)	(Active call state, Idle auxiliary state)	Figures A.1 and A.6
(Active call state, Idle auxiliary state)	(Active call state, Call Held auxiliary state)	Figures A.1 and A.6
(Active call state, Call Held auxiliary state)	(Call Delivered call state, Idle auxiliary state) (note)	Figures A.2 and A.7
(Active call state, Idle auxiliary state)	(Call Delivered call state, Call Held auxiliary state) (note)	Figures A.3 and A.8
NOTE: Only applicable for an outgoing call.		

In order to invoke the ECT supplementary service, an implicit, and, as a network option, an explicit linkage mechanism may be used in the invocation procedure to identify the two calls to be transferred. The implicit linkage mechanism or explicit linkage mechanism can be used if the served user has only one call in the Idle auxiliary state and at least one call in the Call Held auxiliary state. The explicit linkage mechanism shall be used if the served user has more than one call in the Idle auxiliary state and at least one call in the Call Held auxiliary state.

9.2.1 Explicit call transfer request using implicit linkage procedures

9.2.1.1 Normal operation

In order to transfer the two calls into one call between user B and user C, one of the combination of the states in table 4 shall apply. User A shall send a FACILITY message according to the procedures of subclause 8.3.1.1 of ETS 300 196-1 [15] with the call reference of the call in the Call Held auxiliary state and with a Facility information element containing an EctExecute invoke component.

Network A, on receiving such a transfer request, shall follow the procedure of subclause 9.2.3.

9.2.1.2 Exceptional procedures

If network A cannot accept the transfer request, network A shall send a FACILITY message containing an EctExecute return error component to user A, within a Facility information element, using the procedures in subclause 8.3.1.1 of ETS 300 196-1 [15], and indicating one of the following error values:

- "notSubscribed", if the ECT supplementary service is not subscribed to;
- "notAvailable", if the ECT supplementary service is invoked on a non-circuit-switched connection;
- "notAvailable", if network A recognises a looping condition;
- "notAvailable", if network A cannot accept the transfer request due to internal network restrictions;

- "invalidCallState", if the ECT supplementary service is invoked when the call indicated by the call reference is not in the Active call state (N10) or, as a network option, in the Call Delivered call state (N4);
- "invalidCallState", if the ECT supplementary service is invoked when the call indicated by the call reference is not in the Call Held auxiliary state;
- "invalidCallState", if the ECT supplementary service is invoked when the call in the Idle auxiliary state is not in a compatible call state or if there are more than one call in the Idle auxiliary state;
- "supplementaryServiceInteractionNotAllowed", if the ECT supplementary service is invoked when another supplementary service is already activated and network A does not allow this supplementary service interaction.

At user A, on receiving the FACILITY message containing the EctExecute return error component, the calls A-C and A-B shall remain in the call states in which they were before transfer was attempted.

At user A, on receiving the FACILITY message containing a reject component, the calls A-C and A-B shall remain in the call states in which they were before transfer was attempted.

9.2.2 Explicit call transfer request using explicit linkage procedures

9.2.2.1 Requesting a LinkId value

9.2.2.1.1 Normal operation

In order to initiate the explicit linkage procedure, user A shall send a FACILITY message to network A according to the procedures of subclause 8.3.1.1 of ETS 300 196-1 [15] with the call reference of a call to be transferred and with a Facility information element containing an EctLinkIdRequest invoke component.

Network A, on receiving such a request shall:

- issue a LinkId value and associate this value with that call. The LinkId value shall be unique within the data link connection used to control the call; and
- send a FACILITY message according to the procedures of subclause 8.3.1.1 of ETS 300 196-1 [15] to user A, with a Facility information element containing an EctLinkIdRequest return result component carrying the LinkId value.

User A, on receiving a FACILITY message with a Facility information element containing the issued LinkId value in the EctLinkIdRequest return result component, shall store this value for use in subsequent explicit call transfer requests.

When the call associated with a LinkId value is cleared, the LinkId value shall be released by network A and user A.

9.2.2.1.2 Exceptional procedures

If network A receives the EctLinkIdRequest invoke component and is unable to allocate a LinkId value, then network A shall send a FACILITY message according to the procedures of subclause 8.3.1.1 of ETS 300 196-1 [15] with a Facility information element containing an EctLinkIdRequest return error component to the served user. The error shall indicate "resourceUnavailable".

If network A receives the EctLinkIdRequest invoke component when the call indicated by the call reference has already allocated a LinkId value, then network A shall send a FACILITY message according to the procedures of subclause 8.3.1.1 of ETS 300 196-1 [15] with the Facility information element containing a EctLinkIdRequest return result component. The EctLinkIdRequest return result component shall indicate the current LinkId value. At user A, on receiving the FACILITY message with the EctLinkIdRequest return result component indicating the current LinkId value, normal procedures shall apply.

At user A, on receiving the FACILITY message with the EctLinkIdRequest return error component, the calls A-C and A-B shall remain in the basic call states in which they were before the LinkId value was requested.

At user A, on receiving the FACILITY message with a reject component, the calls A-C and A-B shall remain in the basic call states in which they were before the LinkId value was requested.

9.2.2.2 Requesting call transfer

9.2.2.2.1 Normal operation

In order to transfer the two calls into one call between user B and user C one of the combinations of the states in table 4 shall apply. A LinkId value shall have been assigned for the call in the Idle auxiliary state. User A shall send a FACILITY message according to the procedures of subclause 8.3.1.1 of ETS 300 196-1 [15] with the call reference of the call in the Call Held auxiliary state and with a Facility information element containing an ExplicitEctExecute invoke component with the LinkId value received using the procedures in subclause 9.2.2.1.

Network A, on receiving such a transfer request, shall release the LinkId value and follow the procedures of subclause 9.2.3.

9.2.2.2.2 Exceptional procedures

If network A cannot accept the transfer request, network A shall send a FACILITY message containing an ExplicitEctExecute return error component to user A, within a Facility information element, using the procedures in subclause 8.3.1.1 of ETS 300 196-1 [15], and indicating one of the following error values:

- "notSubscribed", if the ECT supplementary service is not subscribed to;
- "notAvailable", if the ECT supplementary service is invoked on a non-circuit-switched connection;
- "notAvailable", if network A recognises a looping condition;
- "notAvailable", if network A cannot accept the transfer request due to internal network restrictions;
- "invalidCallState", if the ECT supplementary service is invoked when the call indicated by the call reference is not in the Active call state (N10) or, as a network option, in the Call Delivered call state (N4);
- "invalidCallState", if the ECT supplementary service is invoked when the call indicated by the call reference is not in the Call Held auxiliary state;
- "invalidCallState", if the ECT supplementary service is invoked when the call identified by the LinkId value is not in a compatible call state;
- "supplementaryServiceInteractionNotAllowed", if the ECT supplementary service is invoked when another supplementary service is already activated and network A does not allow this supplementary service interaction;
- "LinkIdNotAssignedByNetwork", if the received LinkId value has not been assigned.

At user A, on receiving an ExplicitEctExecute return error component, the calls A-C and A-B shall remain in the basic call states in which they were before transfer was attempted.

At user A, on receiving a reject component, the calls A-C and A-B shall remain in the basic call states in which they were before transfer was attempted.

9.2.3 Confirmation of call transfer

9.2.3.1 Normal operation

If the request for call transfer is accepted, network A shall:

- through-connect between the networks of user B and user C;
- send a DISCONNECT message with the call reference of the call in the Call Held auxiliary state, and with a Facility information element containing an EctExecute return result component (if the procedure in subclause 9.2.1 has been used) or an ExplicitEctExecute return result component (if the procedure in subclause 9.2.2 has been used), thereby initiating clearing of the call towards user A according to the procedures of ETS 300 102-1 [11], subclause 5.3.4;
- initiate normal clearing towards user A of the call in the Idle auxiliary state in accordance with the procedures of ETS 300 102-1 [11], subclause 5.3.4.

User A on receiving the DISCONNECT messages shall continue call clearing in accordance with ETS 300 102-1 [11], subclause 5.3.4.

9.2.3.2 Exceptional procedures

Not applicable.

9.2.4 Procedures for remote users when both calls to the users are in the Active call state

9.2.4.1 Normal operation

When call transfer is indicated to the remote networks while the call to user C is in the Active call state:

- network C shall send a FACILITY message to user C according to the procedures of subclause 8.3.1.1 of ETS 300 196-1 [15], with a Notification indicator information element carrying information about the transfer and a Redirection number information element containing the ISDN number of user B (subject to restriction) and a Facility information element containing a RequestSubaddress invoke component. The information sent to user C shall be according to tables 5 or 6;
- network B shall send a FACILITY message to user B according to the procedures of subclause 8.3.1.1 of ETS 300 196-1 [15], with a Notification indicator information element carrying information about the transfer and a Redirection number information element containing the ISDN number of user C (subject to restriction) and a Facility information element containing a RequestSubaddress invoke component. The information sent to user C shall be according to tables 7 or 8.

When user C receives a RequestSubaddress invoke component, user C may send a FACILITY message to network C according to the procedures of subclause 8.3.1.1 of ETS 300 196-1 [15] with a Facility information element containing the C user's subaddress in a SubaddressTransfer invoke component. This indication shall be passed by network C to network B.

On receipt of this indication, network B shall send a FACILITY message according to the procedures of subclause 8.3.1.1 of ETS 300 196-1 [15] to user B with a Facility information element containing the SubaddressTransfer invoke component, with user C's subaddress.

When user B receives a RequestSubaddress invoke component, user B may send a FACILITY message to network B according to the procedures of subclause 8.3.1.1 of ETS 300 196-1 [15] with a Facility information element containing the B user's subaddress in a SubaddressTransfer invoke component. This indication shall be passed by network B to network C.

On receipt of this indication, network C shall send a FACILITY message according to the procedures of subclause 8.3.1.1 of ETS 300 196-1 [15] to user C with a Facility information element containing the SubaddressTransfer invoke component, with user B's subaddress.

9.2.4.2 Exceptional procedures

Not applicable.

9.2.5 Procedures for remote users with one of the calls to the users in the Call Delivered call state (network option)

9.2.5.1 Normal operation

When call transfer is indicated to the remote networks while the call to user C is in the Call Delivered call state:

- network B shall send a FACILITY message according to the procedures of subclause 8.3.1.1 of ETS 300 196-1 [15] to user B, with a Notification indicator information element carrying information about the transfer and a Facility information element containing a RequestSubaddress invoke component. The information sent to user B shall be according to table 7;
- network C shall send a NOTIFY message according to the procedures of subclause 9.3 of ETS 300 196-1 [15] to user C, with a Notification indicator information element carrying information about the transfer and a Redirection number information element containing the ISDN number of user B (subject to restriction). If a point-to-multipoint configuration exists at user C's interface, the network shall send a NOTIFY message to each responding user. The information sent to user C shall be according to tables 5 or 6.

When user B receives a RequestSubaddress invoke component, user B may send a FACILITY message to network B according to the procedures of subclause 8.3.1.1 of ETS 300 196-1 [15] with a Facility information element containing the B user's subaddress in a SubaddressTransfer invoke component. This indication shall be passed by network B to network C.

On receipt of this indication, network C shall send a FACILITY message according to the procedures of subclause 8.3.1.1 of ETS 300 196-1 [15] to user C with a Facility information element containing the SubaddressTransfer invoke component and with user B's subaddress. If a point-to-multipoint configuration exists at user C's interface, network C shall send a FACILITY message to each responding user.

When network C receives a CONNECT message from user C, network C shall proceed with basic call procedures for user C in accordance with ETS 300 102-1 [11], subclause 5.2.8.

On receipt of the indication that the call to user C has been established, network B shall:

- if user C has provided a subaddress and the address is not subject to restriction, network B shall send a FACILITY message to user B according to the procedures of subclause 8.3.1.1 of ETS 300 196-1 [15], with a Notification indicator information element carrying information about the transfer, a Redirection number information element containing the ISDN number of user C and a Facility information element containing the SubaddressTransfer invoke component with user C's subaddress. The information shall be according to table 7;
- if user C has not provided a subaddress, or the address is subject to restriction, network B shall send a NOTIFY message to user B according to the procedures of subclause 9.3. of ETS 300 196-1 [15], with a Notification indicator information element carrying information about the transfer, and a Redirection number information element containing the ISDN number of user C information (subject to restriction). The information shall be according to table 7.

9.2.5.2 Exceptional procedures

Not applicable.

9.3 Content of notification information

Tables 5 to 8 indicate the information to be provided in the Notification indicator information element and Redirection number information element when the users B and C are notified. Call states refer to the time of ECT invocation at that time one of the calls is on hold.

If user B was the called user in the call A-B, table 5 applies to the information supplied to user C; otherwise table 6 is used.

Likewise, if user C was the called user in the call A-C, table 7 applies to the information supplied to user B; otherwise table 8 is used.

Table 5: Information provided to user C when user B is the called user in the call A-B

Call states	COLR indication received from network B	Information provided to user C
A-B Active A-C Active/Call Delivered	Indicated "allowed"	At time of transfer: NIE: "call transferred, active". RDNIE: user B's number (note 1)
A-B Active A-C Active/Call Delivered	Indicated "restricted"	At time of transfer: NIE: "call transferred, active". RDNIE: (note 2)
A-B Active A-C Active/Call Delivered	No indication received (e.g. interworking)	At time of transfer: NIE: "call transferred, active". RDNIE: (note 3)
NOTE 1:	The fields within the Redirection number information element shall be processed as defined for the equivalent fields in the Connected number information element in ETS 300 097-1 [10]. In particular:	
	<ul style="list-style-type: none"> - the numbering plan identifier field shall be processed as specified in subclause 9.5.1, third paragraph of ETS 300 097-1 [10]; - the presentation indicator field shall be processed as specified in subclause 9.5.1, second paragraph of ETS 300 097-1 [10]; - the type of number field shall follow any of the network options specified in table 1 and table 2 of ETS 300 097-1 [10], and the number digits field shall be processed appropriately for the setting of the type of number field. 	
NOTE 2:	The fields within the Redirection number information element shall be processed as defined for the equivalent fields in the Connected number information element in ETS 300 097-1 [10], subclause 9.5.1, fourth paragraph.	
NOTE 3:	The fields within the Redirection number information element shall be processed as defined for the equivalent fields in the Connected number information element in ETS 300 097-1 [10], subclause 9.5.1, fifth paragraph.	

Table 6: Information provided to user C when user B is the calling user in the call A-B

Call states	CLIR indication received from network B	Information provided to user C
A-B Active A-C Active/Call Delivered	Indicated "allowed"	At time of transfer: NIE: "call transferred, active". RDNIE: user B's number (note 1)
A-B Active A-C Active/Call Delivered	Indicated "restricted"	At time of transfer: NIE: "call transferred, active". RDNIE: (note 2)
A-B Active A-C Active/Call Delivered	No indication received (e.g. interworking)	At time of transfer: NIE: "call transferred, active". RDNIE: (note 3)
<p>NOTE 1: The fields within the Redirection number information element shall be processed as defined for the equivalent fields in the Calling party number information element in ETS 300 092-1 [9]. In particular:</p> <ul style="list-style-type: none"> - the numbering plan identifier field shall be processed as specified in subclause 9.5.1, third paragraph of ETS 300 092-1 [9]; - the presentation indicator field shall be processed as specified in subclause 9.5.1, second paragraph of ETS 300 092-1 [9]; - the type of number field shall follow any of the network options specified in table 1 and table 2 of ETS 300 092-1 [9], and the number digits field shall be processed appropriately for the setting of the type of number field. <p>NOTE 2: The fields within the Redirection number information element shall be processed as defined for the equivalent fields in the Calling party number information element in ETS 300 092-1 [9], subclause 9.5.1, fourth paragraph.</p> <p>NOTE 3: The fields within the Redirection number information element shall be processed as defined for the equivalent fields in the Calling party number information element in ETS 300 092-1 [9], subclause 9.5.1, fifth paragraph.</p>		

Table 7: Information provided to user B when user C is the called user in the call A-C

Call states	COLR indication received from network C	Information provided to user B
A-B Active A-C Active	Indicated "allowed"	At time of transfer: NIE: "call transferred, active" RDNIE: (note 1)
A-B Active A-C Active	Indicated "restricted"	At time of transfer: NIE: "call transferred, active". RDNIE: (note 2)
A-B Active A-C Active	No indication received (e.g. interworking)	At time of transfer: NIE: "call transferred, active". RDNIE: (note 3)
A-B Active A-C Call Delivered	Indicated "allowed" at receipt of connect indication	At time of transfer: NIE: "call transferred, alerting". At user C CONNECT: NIE: "call transferred, active". RDNIE: (note 1)
A-B Active A-C Call Delivered	Indicated "restricted" at receipt of connect indication	At time of transfer: NIE: "call transferred, alerting". At user C CONNECT: NIE: "call transferred, active". RDNIE: (note 2)
A-B Active A-C Call Delivered	No indication received (e.g. interworking)	At time of transfer: NIE: "call transferred, alerting". At user C CONNECT: NIE: "call transferred, active". RDNIE: (note 3)
<p>NOTE 1: The fields within the Redirection number information element shall be processed as defined for the equivalent fields in the Connected number information element in ETS 300 097-1 [10]. In particular:</p> <ul style="list-style-type: none"> - the numbering plan identifier field shall be processed as specified in subclause 9.5.1, third paragraph of ETS 300 097-1 [10]; - the presentation indicator field shall be processed as specified in subclause 9.5.1, second paragraph of ETS 300 097-1 [10]; - the type of number field shall follow any of the network options specified in table 1 and table 2 of ETS 300 097-1 [10], and the number digits field shall be processed appropriately for the setting of the type of number field. <p>NOTE 2: The fields within the Redirection number information element shall be processed as defined for the equivalent fields in the Connected number information element in ETS 300 097-1 [10], subclause 9.5.1, fourth paragraph.</p> <p>NOTE 3: The fields within the Redirection number information element shall be processed as defined for the equivalent fields in the Connected number information element in ETS 300 097-1 [10], subclause 9.5.1, fifth paragraph.</p>		

Table 8: Information provided to user B when user C is the calling user in the call A-C

Call states	CLIR indication received from network C	Information provided to user B
A-B Active A-C Active	Indicated "allowed"	At time of transfer: NIE: "call transferred, active". RDNIE: user C's number (note 1)
A-B Active A-C Active	Indicated "restricted"	At time of transfer: NIE: "call transferred, active". RDNIE: (note 2)
A-B Active A-C Active	No indication received (e.g. interworking)	At time of transfer: NIE: "call transferred, active". RDNIE: (note 3)
NOTE 1:	The fields within the Redirection number information element shall be processed as defined for the equivalent fields in the Calling party number information element in ETS 300 092-1 [9]. In particular:	
	<ul style="list-style-type: none"> - the numbering plan identifier field shall be processed as specified in subclause 9.5.1, third paragraph of ETS 300 092-1 [9]; - the presentation indicator field shall be processed as specified in subclause 9.5.1, second paragraph of ETS 300 092-1 [9]; - the type of number field shall follow any of the network options specified in table 1 and table 2 of ETS 300 092-1 [9], and the number digits field shall be processed appropriately for the setting of the type of number field. 	
NOTE 2:	The fields within the Redirection number information element shall be processed as defined for the equivalent fields in the Calling party number information element in ETS 300 092-1 [9], subclause 9.5.1, fourth paragraph.	
NOTE 3:	The fields within the Redirection number information element shall be processed as defined for the equivalent fields in the Calling party number information element in ETS 300 092-1 [9], subclause 9.5.1, fifth paragraph.	

10 Procedures for interworking with private ISDNs

10.1 Served user is connected to the private ISDN

10.1.1 Normal operation

When the ECT supplementary service is invoked in a private network, the transfer of the involved users shall be performed within the private network.

In such a situation user B and/or user C can be located in the public network, i.e. the private network has one or two calls to the public network.

In order to avoid looping of uncontrolled circuits, the optional procedures specified in subclause 10.3.1.1 may be applied.

For each call to the public network the following procedure shall apply:

After transfer, the private network shall send a FACILITY message to the public network using the call reference of the call to the remote user and the procedures of ETS 300 196-1 [15], subclause 8.3.1.1. The FACILITY message shall contain a Facility information element with an EctInform invoke component indicating if the other call is "alerting" or "active" and, if that indication is "active", containing the redirectionNumber parameter.

When the public network receives the FACILITY message with the EctInform invoke component, the public network shall send a NOTIFY message according to the procedures of subclause 9.3 of ETS 300 196-1 [15] (if the call is alerting) or a FACILITY message (if the call is active) to user B (C) according to the procedures of subclause 8.3.1.1 of ETS 300 196-1 [15]. The message shall have the same contents as specified in subclauses 9.2.4 and 9.2.5, but the contents of the Redirection number information element shall be as received from the private network, i.e. no restriction check shall be performed by the public network.

If, as a result of the notification, the user B (C) responds with its subaddress by sending a SubaddressTransfer invoke component according to the procedures in subclauses 9.2.4 and 9.2.5, the public network shall convey this subaddress information in a FACILITY message according to the procedures of subclause 8.3.1.1 of ETS 300 196-1 [15], with a Facility information element containing the SubaddressTransfer invoke component and user B (C)'s subaddress to the private network. If user C (B) is located in the public network, the private network shall then convey the subaddress information to user C (B) by sending a similar FACILITY message to the public network which shall convey it to the user C (B).

If transfer occurs before call completion, then when the private network is informed that the other remote user has answered the call, the private network shall send a FACILITY message to the public network using the call reference of the call to the remote user and the procedures of ETS 300 196-1 [15], subclause 8.3.1.1. The FACILITY message shall contain:

- a Facility information element with an EctInform invoke component indicating the other call is "active" and containing the redirectionNumber parameter;
- a Facility information element with a SubaddressTransfer invoke component indicating the subaddress supplied by the other user, if available and not restricted.

When the private network includes an EctInform invoke component containing a redirectionNumber parameter, the field shall be processed as defined for the equivalent fields in the Calling party number information element in ETS 300 092-1 [9]. In particular:

- the numbering plan identifier field shall be processed as specified in subclause 9.5.1, third paragraph of ETS 300 092-1 [9];
- the presentation indicator field shall be processed as specified in subclause 9.5.1, second paragraph of ETS 300 092-1 [9];
- the type of number field shall follow any of the network options specified in table 1 and table 2 of ETS 300 092-1 [9], and the number digits field shall be processed appropriately for the setting of the type of number field.

10.1.2 Exceptional procedures

If the private network receives a FACILITY message containing a reject component as a response to sending an EctInform invoke component, the private network shall take no action.

10.2 Remote user is connected to the private ISDN

10.2.1 Normal operation

When the ECT supplementary service is invoked in a public network and user B and/or user C is attached to a private ISDN, the following procedure shall apply for each of the users connected to a private network.

In order to avoid looping of uncontrolled circuits, the optional procedures specified in subclause 10.3.2.1 may be applied.

After transfer, the public network shall send a FACILITY message to the private network using the call reference of the call to the private network user and the procedures in ETS 300 196-1 [15], subclause 8.3.1.1. The FACILITY message shall contain a Facility information element with an EctInform invoke component indicating if the other call is "alerting" or "active" and, if that indication is "active", containing the redirectionNumber parameter taking into account the restrictions described in subclause 9.2.

If the private network wants to send its user's subaddress to the other user, the private network shall send a FACILITY message according to the procedures of subclause 8.3.1.1 of ETS 300 196-1 [15], with a Facility information element containing the SubaddressTransfer invoke component with the subaddress to the public network.

The public network shall convey the subaddress to the other user according to subclause 9.2.4.1 or subclause 9.2.5.1, respectively, by sending a FACILITY message according to the procedures of subclause 8.3.1.1 of ETS 300 196-1 [15] to that user or to the private network depending on the user's location.

If transfer occurs before call completion, then when the public network is informed that the other remote user has answered the call, the public network shall send a FACILITY message to the private network using the call reference of the call to the remote user and the procedures of ETS 300 196-1 [15], subclause 8.3.1.1. The FACILITY message shall contain:

- a Facility information element with an EctInform invoke component indicating the other call is "active" and containing the redirectionNumber parameter;
- a Facility information element with a SubaddressTransfer invoke component indicating the subaddress supplied by the other user, if available and not restricted.

When the public network includes an EctInform invoke component containing a redirectionNumber parameter, the field shall be processed as defined for the equivalent fields in the Calling party number information element in ETS 300 092-1 [9]. In particular:

- the numbering plan identifier field shall be processed as specified in subclause 9.5.1, third paragraph of ETS 300 092-1 [9];
- the presentation indicator field shall be processed as specified in subclause 9.5.1, second paragraph of ETS 300 092-1 [9];
- the type of number field shall follow any of the network options specified in table 1 and table 2 of ETS 300 092-1 [9], and the number digits field shall be processed appropriately for the setting of the type of number field.

10.2.2 Exceptional procedures

If the public network receives a FACILITY message containing a reject component as a response to sending an EctInform invoke component, the public network shall take no action.

10.3 Procedures for the mechanism to avoid looping of uncontrolled circuits

This subclause specifies optional procedures which, prior to transfer, can be used by the private network and the public network to avoid looping of uncontrolled circuits.

10.3.1 Procedures at the served network side

10.3.1.1 Normal operation

If the private network supports "the mechanism to avoid looping of uncontrolled circuits", it shall before transfer, for each of the individual calls involved in the transfer, send a FACILITY message to the public network using the call reference of that call and the procedures of subclause 8.3.1.1 of ETS 300 196-1 [15]. The FACILITY message shall contain a Facility information element with an EctLoopTest invoke component. The CallTransferIdentity parameter shall contain a value to identify the specific loop test.

If the public network supports the network option "mechanism to avoid looping of uncontrolled circuit" and based on the result of the treatment of the loop test in the remote user's network, the public network shall send a FACILITY message according to the procedures of subclause 8.3.1.1 of ETS 300 196-1 [15], with

a Facility information element containing an EctLoopTest return result component. The LoopResult parameter shall indicate either "insufficientInformation", "noLoopExists" or "simultaneousTransfer".

NOTE: The decision as to whether the transfer can occur is the responsibility of the private ISDN.

10.3.1.2 Exceptional procedures

If the public network has implemented "the mechanism to avoid looping of uncontrolled circuits" but cannot support the loop checking for this particular call, and it receives a FACILITY message with a Facility information element containing an EctLoopTest invoke component, it shall send a FACILITY message with a Facility information element and with a EctLoopTest return error component to the private network according to ETS 300 196-1 [15], subclause 8.3.1.1. The error value shall indicate "notAvailable".

If the private network receives a FACILITY message containing a reject component as a response to sending an EctLoopTest invoke component, the private network shall take no action.

10.3.2 Procedures at the remote network side

10.3.2.1 Normal operation

Before transfer, provided that the public network supports the network option "mechanism to avoid looping of uncontrolled circuits", it shall, based on the receipt of a request from the served user's network send a FACILITY message to the private network using the call reference of the individual call and according to the procedures of subclause 8.3.1.1 of ETS 300 196-1 [15]. The FACILITY message shall contain a Facility information element with an EctLoopTest invoke component. The CallTransferIdentity parameter shall contain the value received from the remote network, if available.

The private network when receiving a FACILITY message with a Facility information element and with an EctLoopTest invoke component shall send a FACILITY message with a Facility information element containing an EctLoopTest return result component according to ETS 300 196-1 [15], subclause 8.3.1.1. The LoopResult parameter shall indicate either "insufficientInformation", "noLoopExists" or "simultaneousTransfer".

NOTE: The decision as to whether the transfer can occur is the responsibility of the public ISDN.

10.3.2.2 Exceptional procedures

If the private network has implemented "the mechanism to avoid looping of uncontrolled circuits" but cannot support the loop checking for this particular call, and it receives a FACILITY message with a Facility information element containing an EctLoopTest invoke component, it shall send a FACILITY message according to the procedures of subclause 8.3.1.1 of ETS 300 196-1 [15], with a Facility information element and with an EctLoopTest return error component to the public network. The error value shall indicate "notAvailable".

If the public network receives a FACILITY message containing a reject component as a response to sending an EctLoopTest invoke component, the public network shall take no action.

11 Interactions with other networks

If a transferred user is not within the ISDN, it need not be possible to notify that user about the transfer. Also, the address of a transferred user that is not within the ISDN may be unavailable (e.g. no information available or information not available due to restrictions agreed between the network providers). The delivery of address information in such cases is given in tables 5 to 8.

12 Interaction with other supplementary services

The interaction of the ECT supplementary service with other supplementary services shall be as specified in ETS 300 195-1 [14].

13 Parameter values (timers)

No specific timers are required.

14 Dynamic description

The dynamic description specified in figures 1 to 5 is according to CCITT Recommendation Z.100 [8].

14.1 User side SDL diagrams

In the context of this ETS, the direction of the input symbol and the output symbol at the user side is defined as follows:

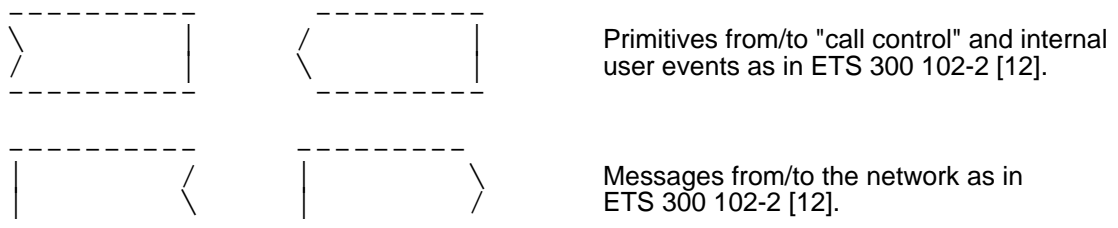

This subclause contains the following user side SDL diagrams:

- Figure 1: ECT user A, ECT execute
- Figure 2: ECT user A, ECT LinkId request

This process is associated with the call in the Call Held auxiliary state.

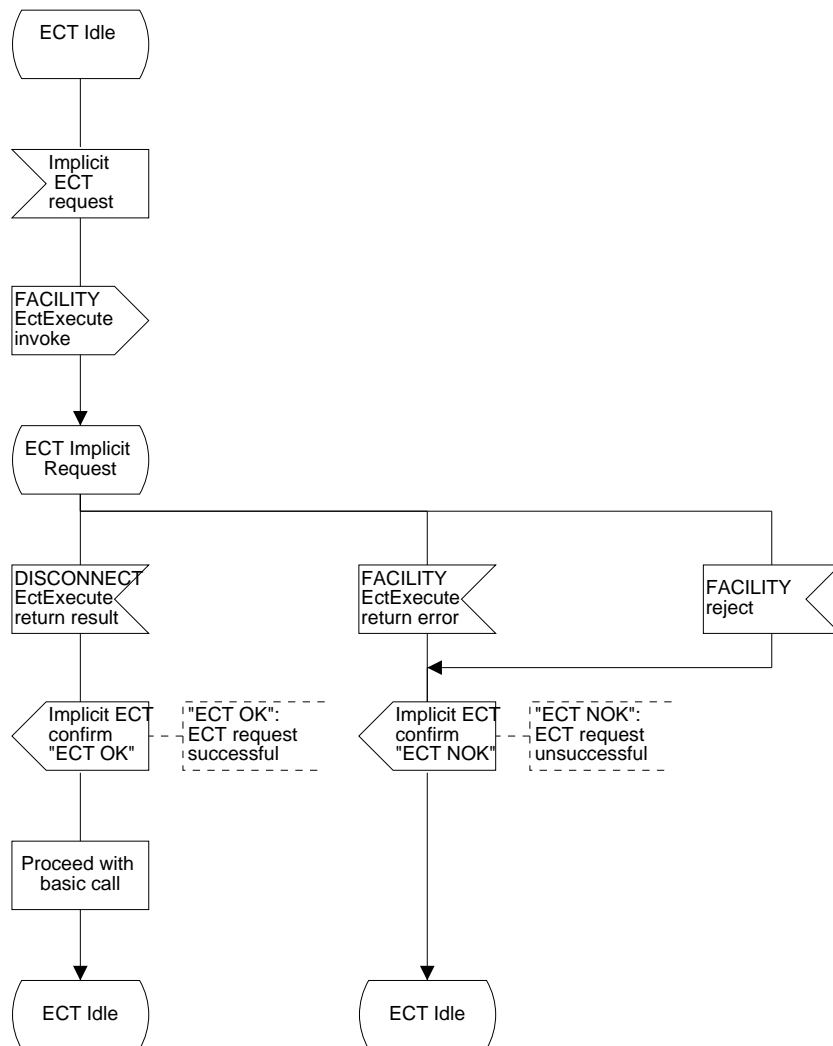

Figure 1 (sheet 1 of 3): ECT user A, ECT execute

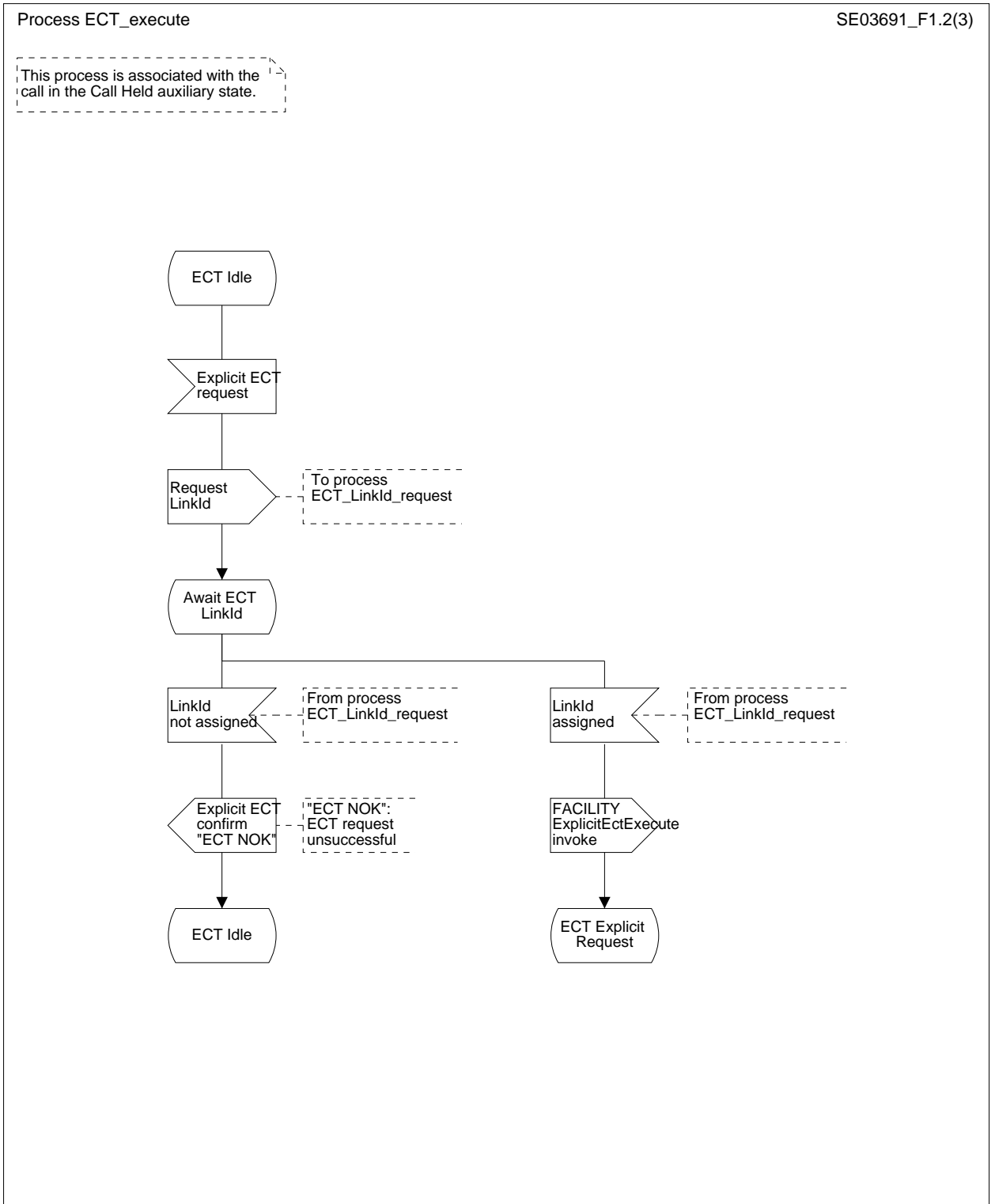

Figure 1 (sheet 2 of 3): ECT user A, ECT execute

This process is associated with the call in the Call Held auxiliary state.

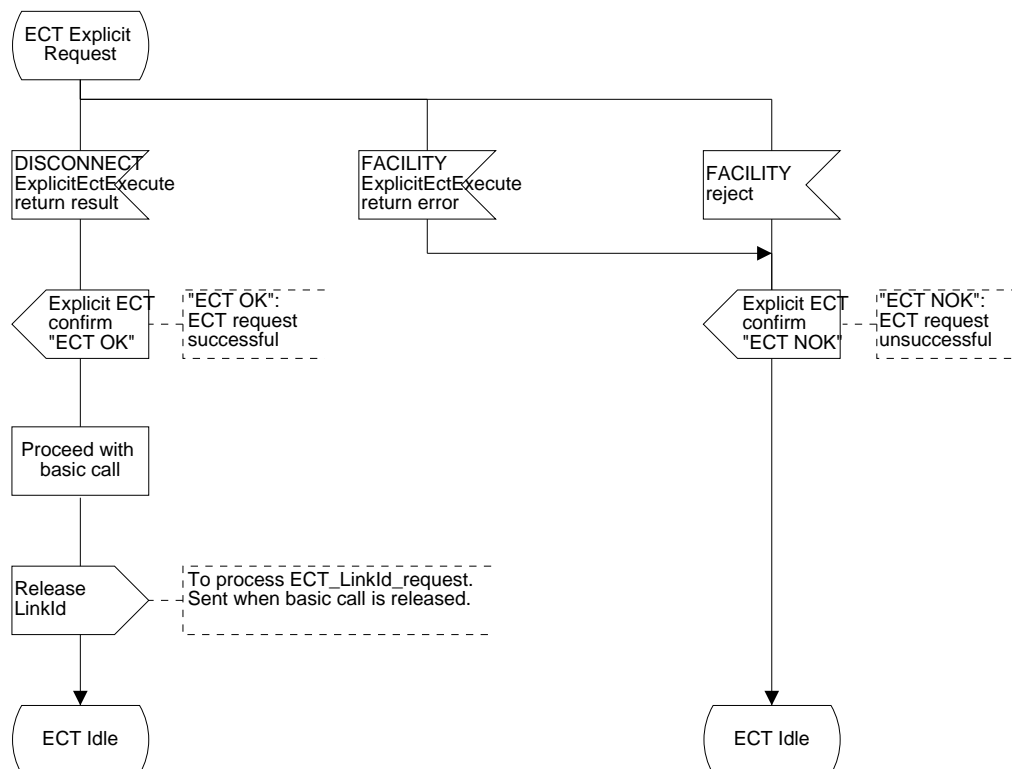

Figure 1 (sheet 3 of 3): ECT user A, ECT execute

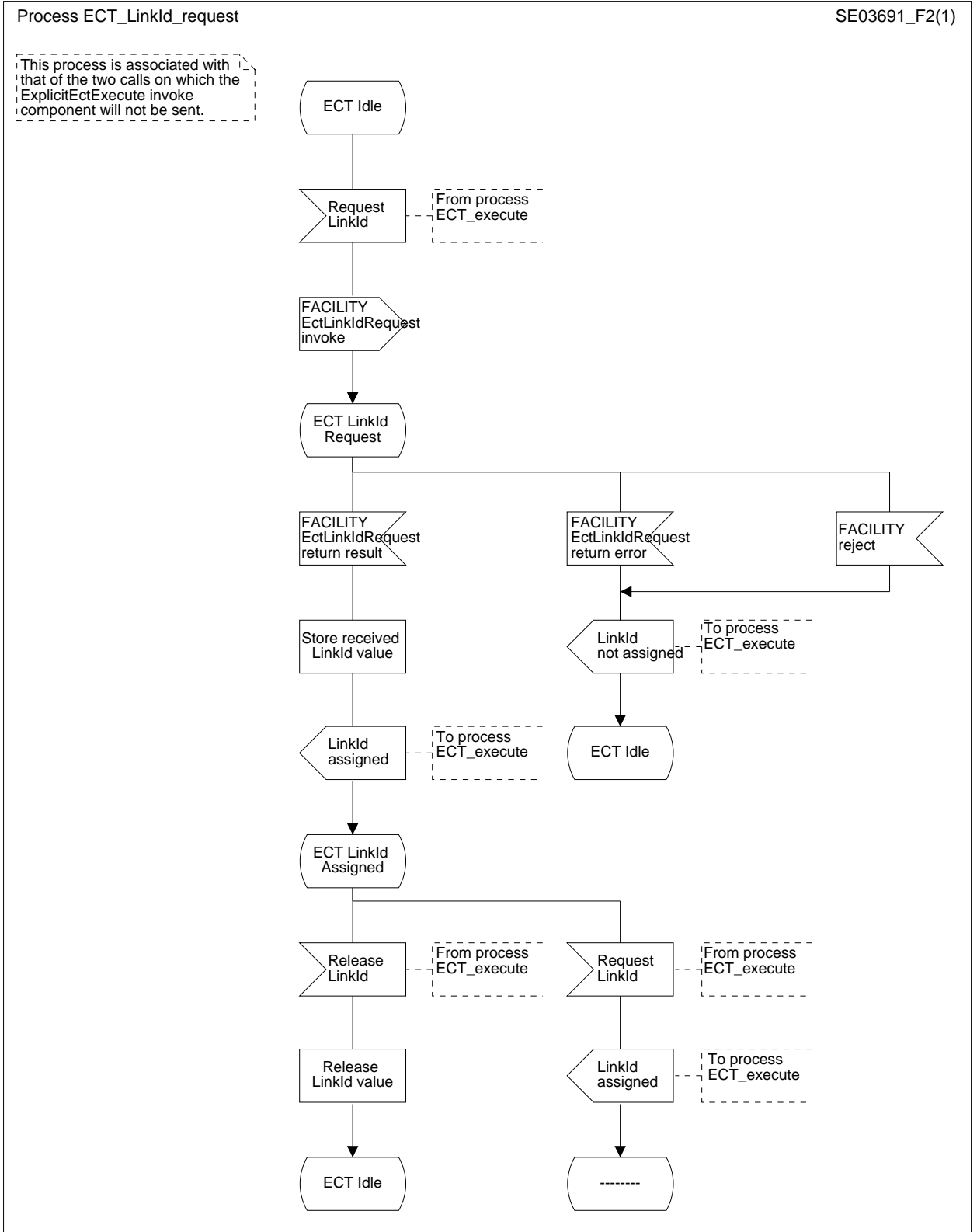

Figure 2: ECT user A, ECT LinkId request

14.2 Network side SDL diagrams

In the context of this ETS, the direction of the input symbol and the output symbol at the network side is defined as follows:



Messages from/to the user as in ETS 300 102-2 [12].



Primitives from/to "call control" and internal network events as in ETS 300 102-2 [12].

This subclause contains the following network side SDL diagrams:

- Figure 3: ECT network A
- Figure 4: ECT network B
- Figure 5: ECT network C

In the figures, the following definitions apply:

TRANSFER COMPLETE: An indication to network B and network C containing the transferred number, the transferred subaddress and the "alerting" or "active" indication.

TRANSFER INFORM: An indication to network B and network C containing the transferred subaddress and the "active" indication.

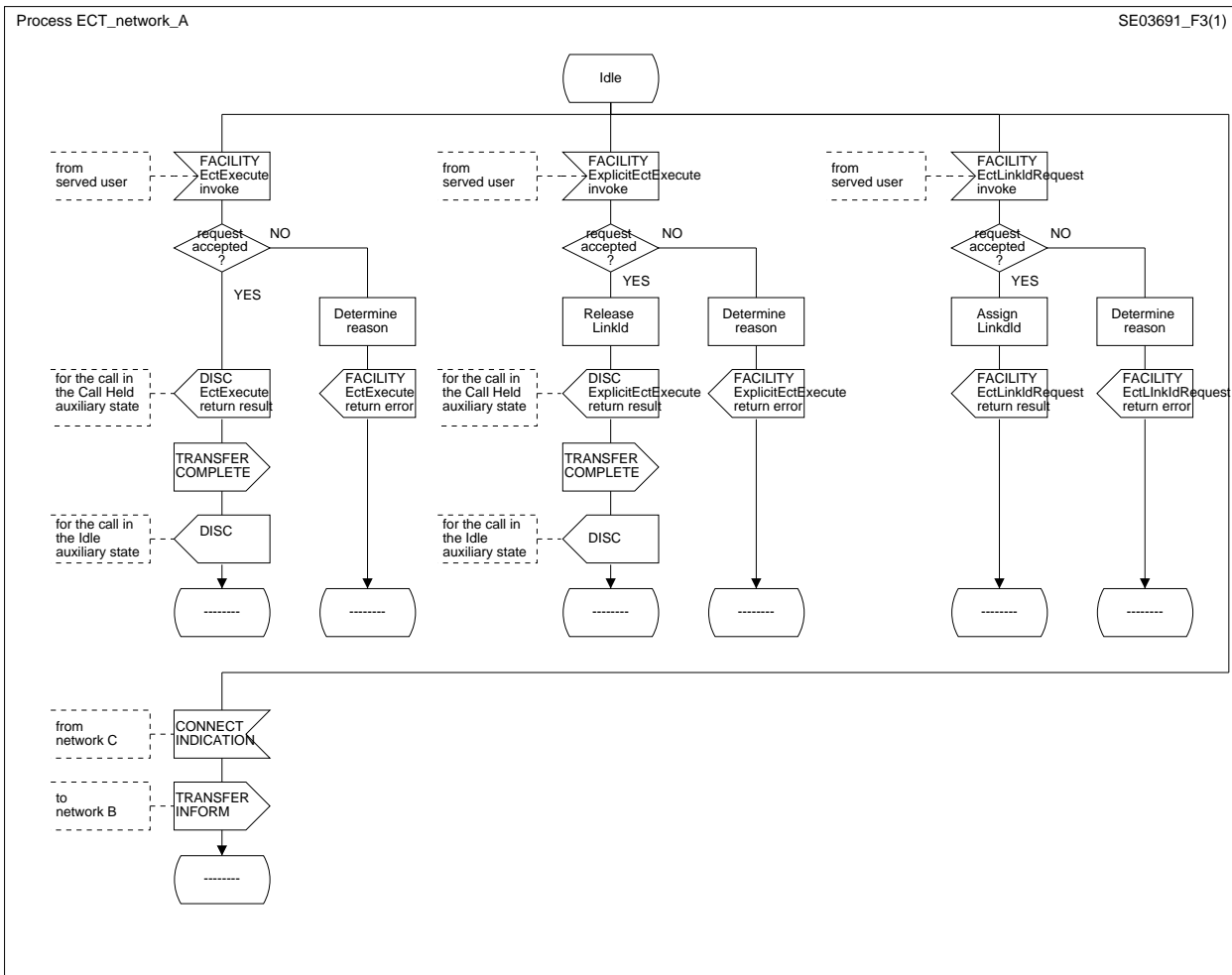

Figure 3: ECT network A

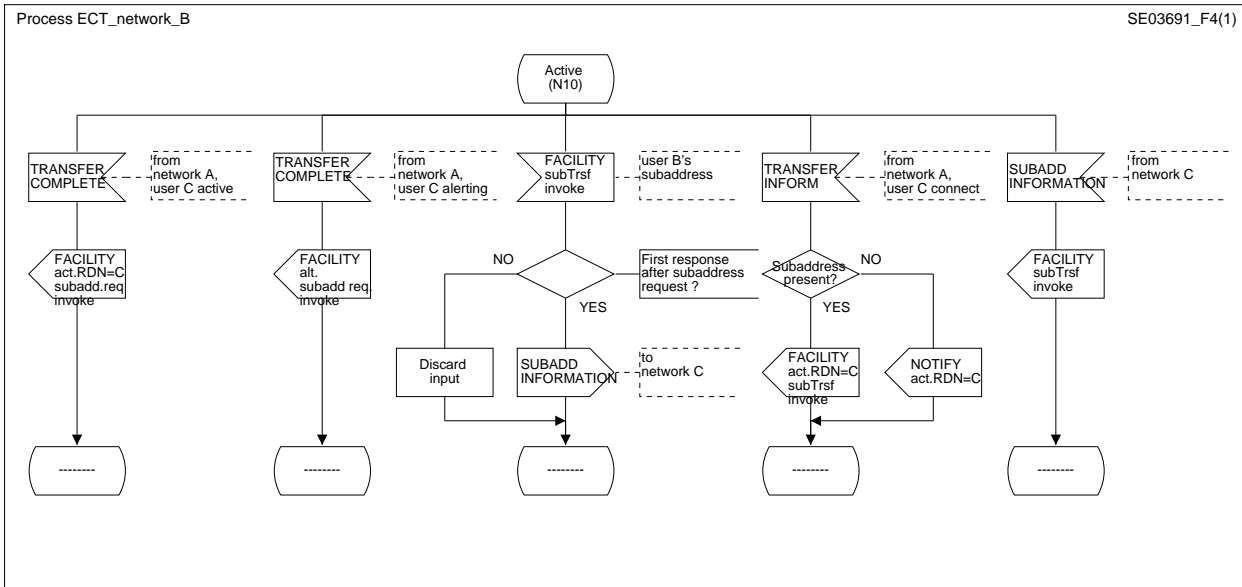

Figure 4: ECT network B

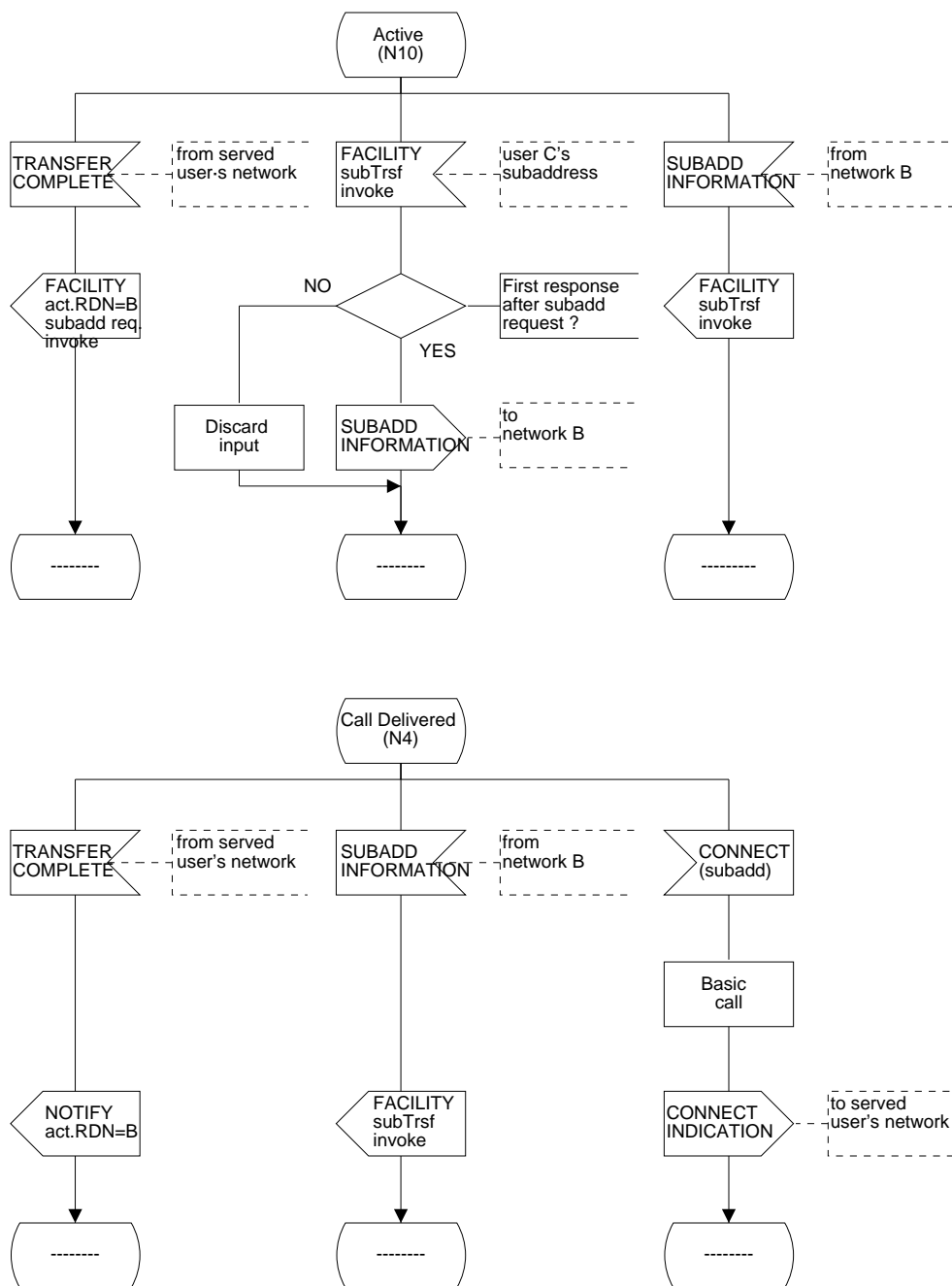

Figure 5: ECT network C

Annex A (informative): Signalling flows

This annex contains the signalling flows for the different cases of the ECT supplementary service.

- Figure A.1: ECT implicit invocation (A-B Active, Call Held) - Transfer after answer
- Figure A.2: ECT implicit invocation (A-C Alerting) - Transfer while alerting
- Figure A.3: ECT implicit invocation (A-C Alerting, Call Held) - Transfer while alerting
- Figure A.4: ECT explicit invocation - EctExecute fails
- Figure A.5: ECT explicit invocation - LinkId request fails
- Figure A.6: ECT explicit invocation (A-B Active, Call Held) - Transfer after answer
- Figure A.7: ECT explicit invocation (A-C Alerting) - Transfer while alerting
- Figure A.8: ECT explicit invocation (A-C Alerting, Call Held) - Transfer while alerting
- Figure A.9: Served user in a private ISDN
- Figure A.10: Remote user in a private ISDN

Table A.1: Abbreviations used in the signalling diagrams

CR1, CR2	Call reference values
RDN	Redirection number contained in the EctInform invoke component
A, B, C	ISDN number of user A, B or C
FIE	Facility information element
RR	Return result
RE	Return error

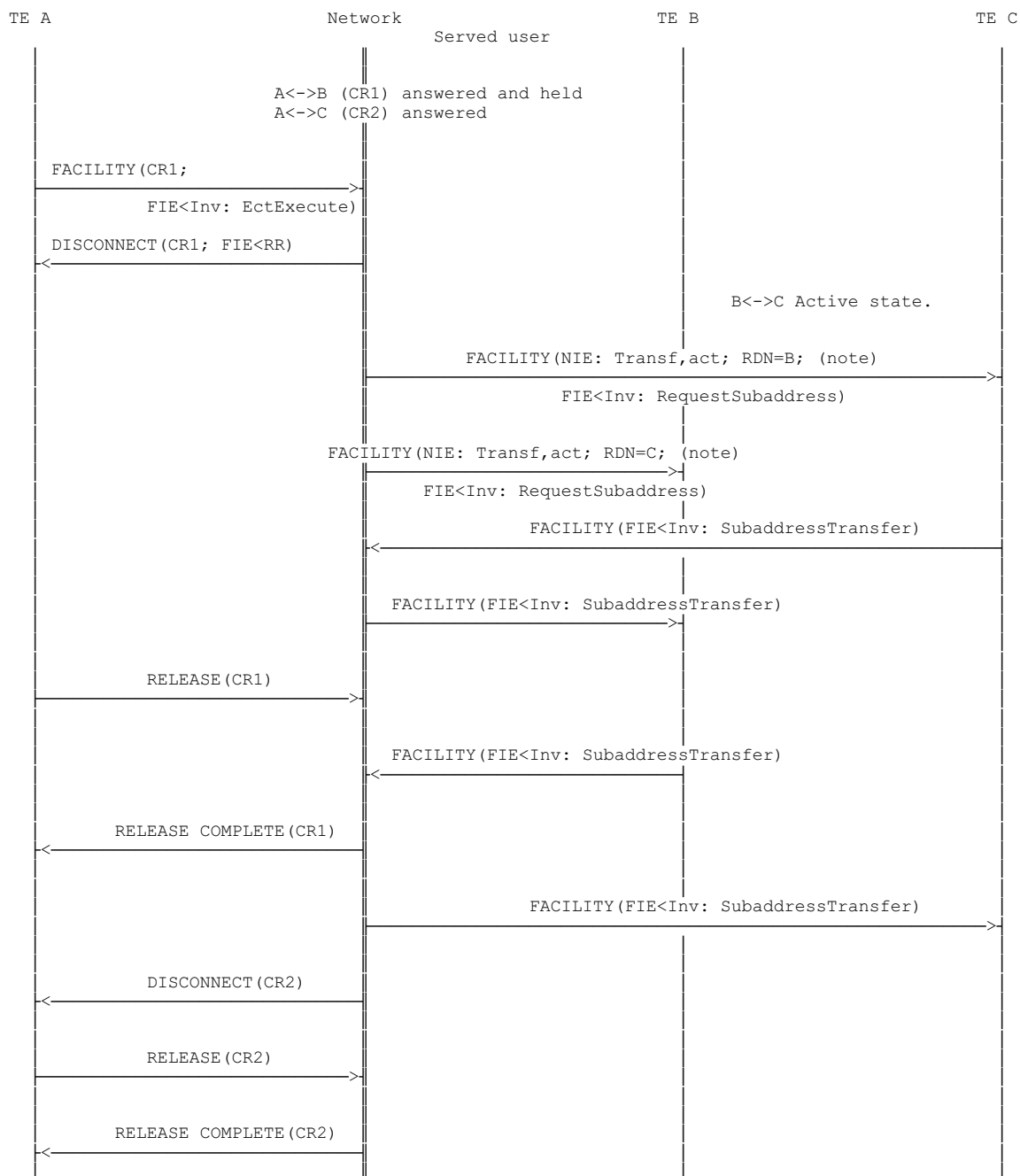

NOTE: RDN included if allowed, see tables 5 to 8.

Figure A.1: ECT implicit invocation - Transfer after answer

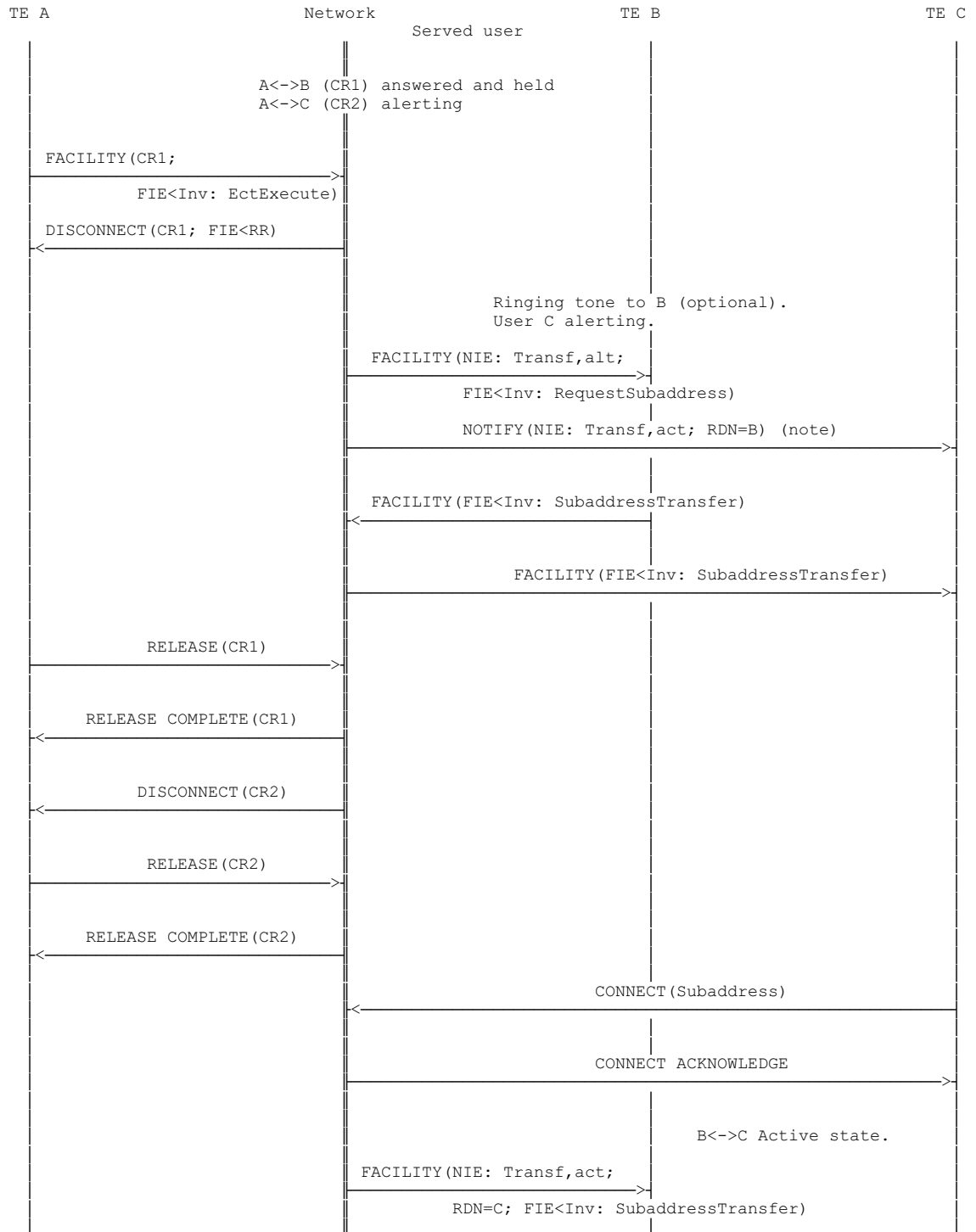

NOTE: RDN included if allowed, see tables 5 to 8.

Figure A.2: ECT implicit invocation - Transfer while alerting

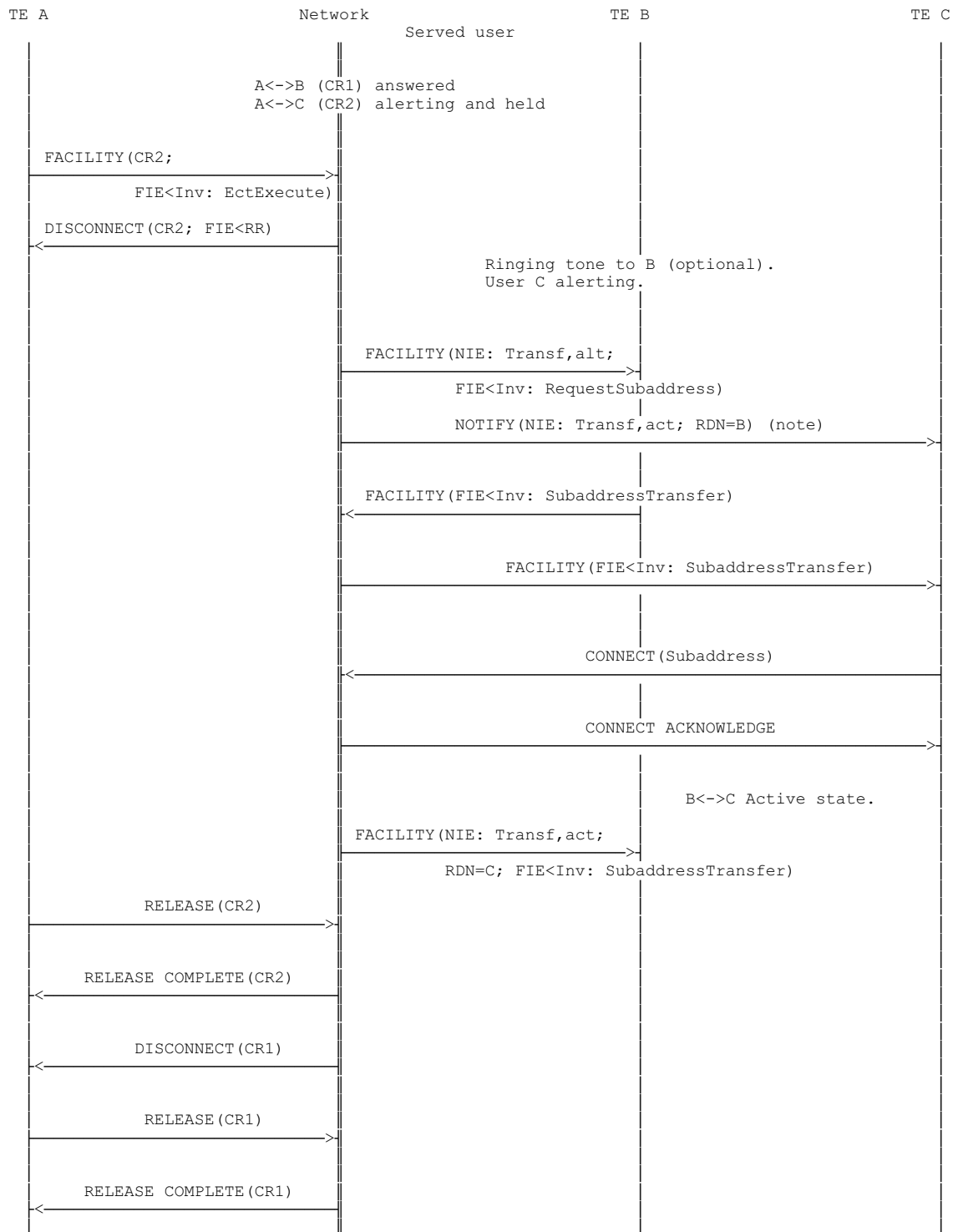

NOTE: RDN included if allowed, see tables 5 to 8.

Figure A.3: ECT implicit invocation - Transfer while alerting

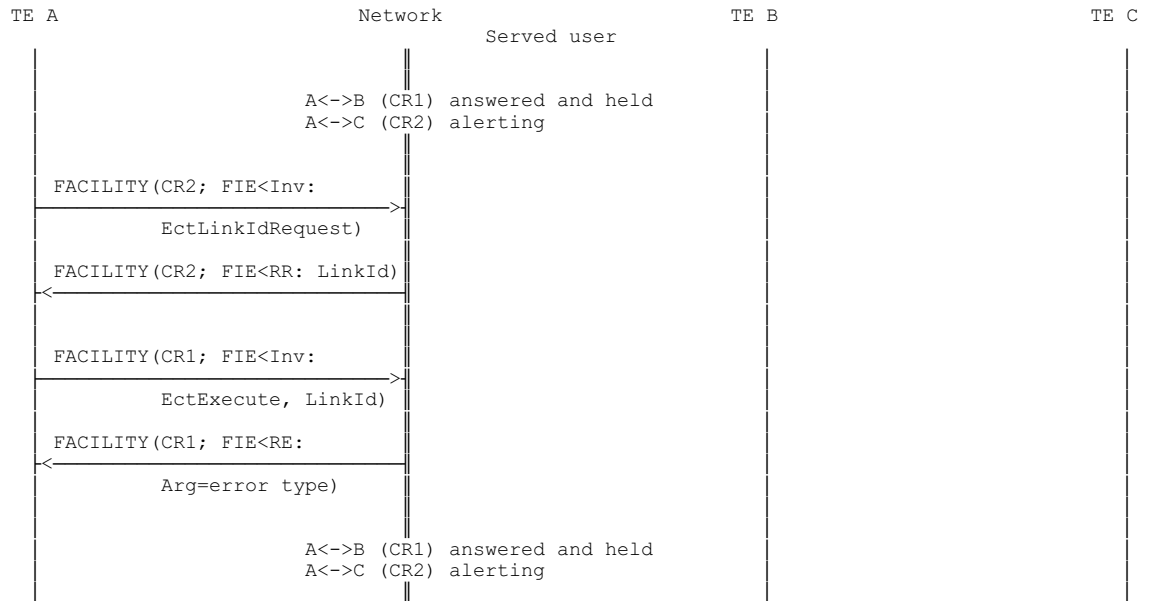

Figure A.4: ECT explicit invocation - EctExecute fails

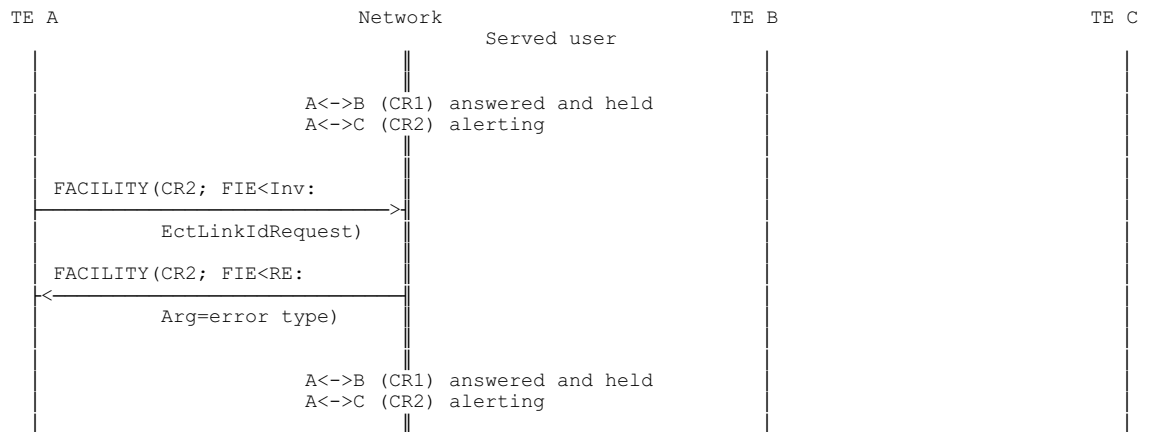
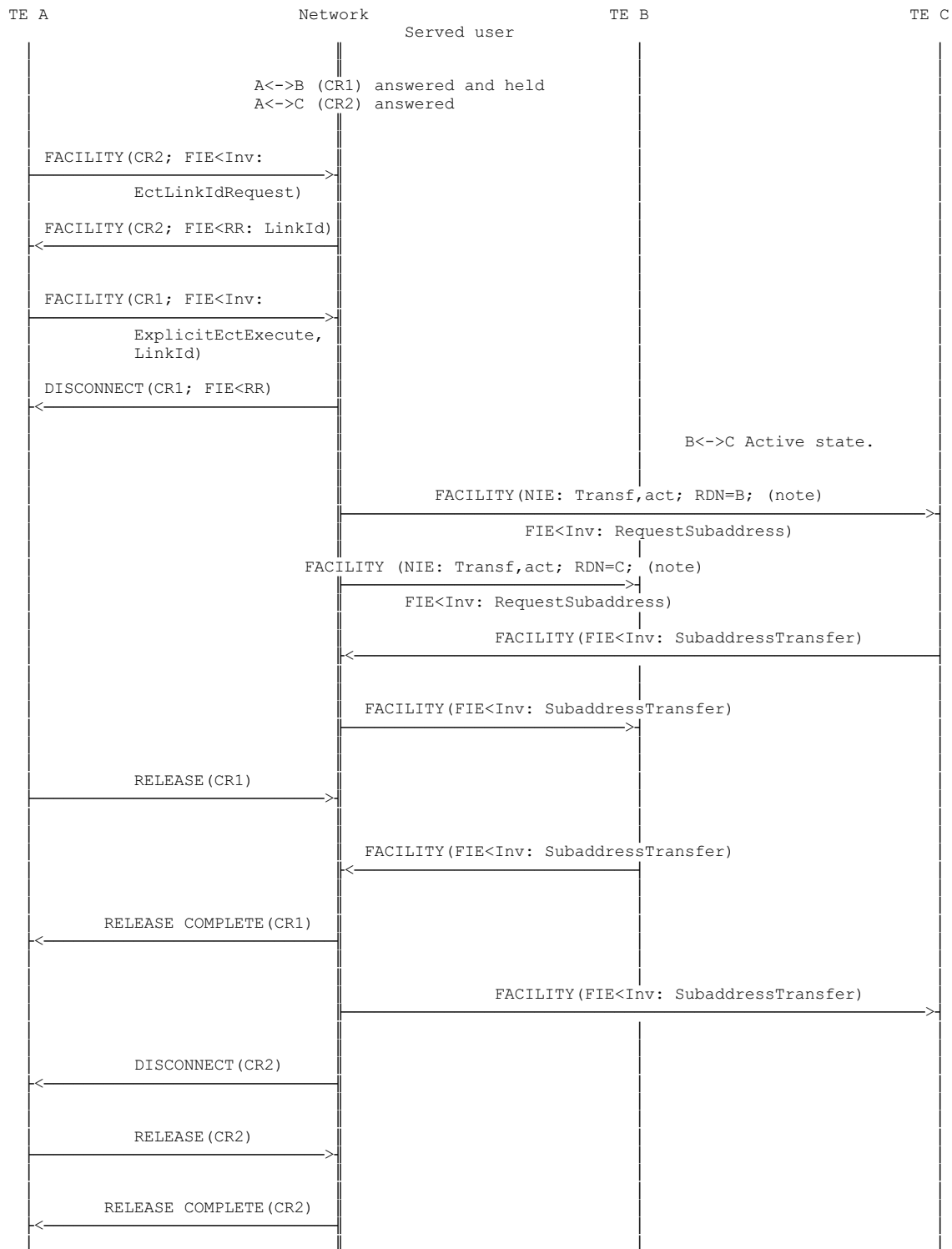
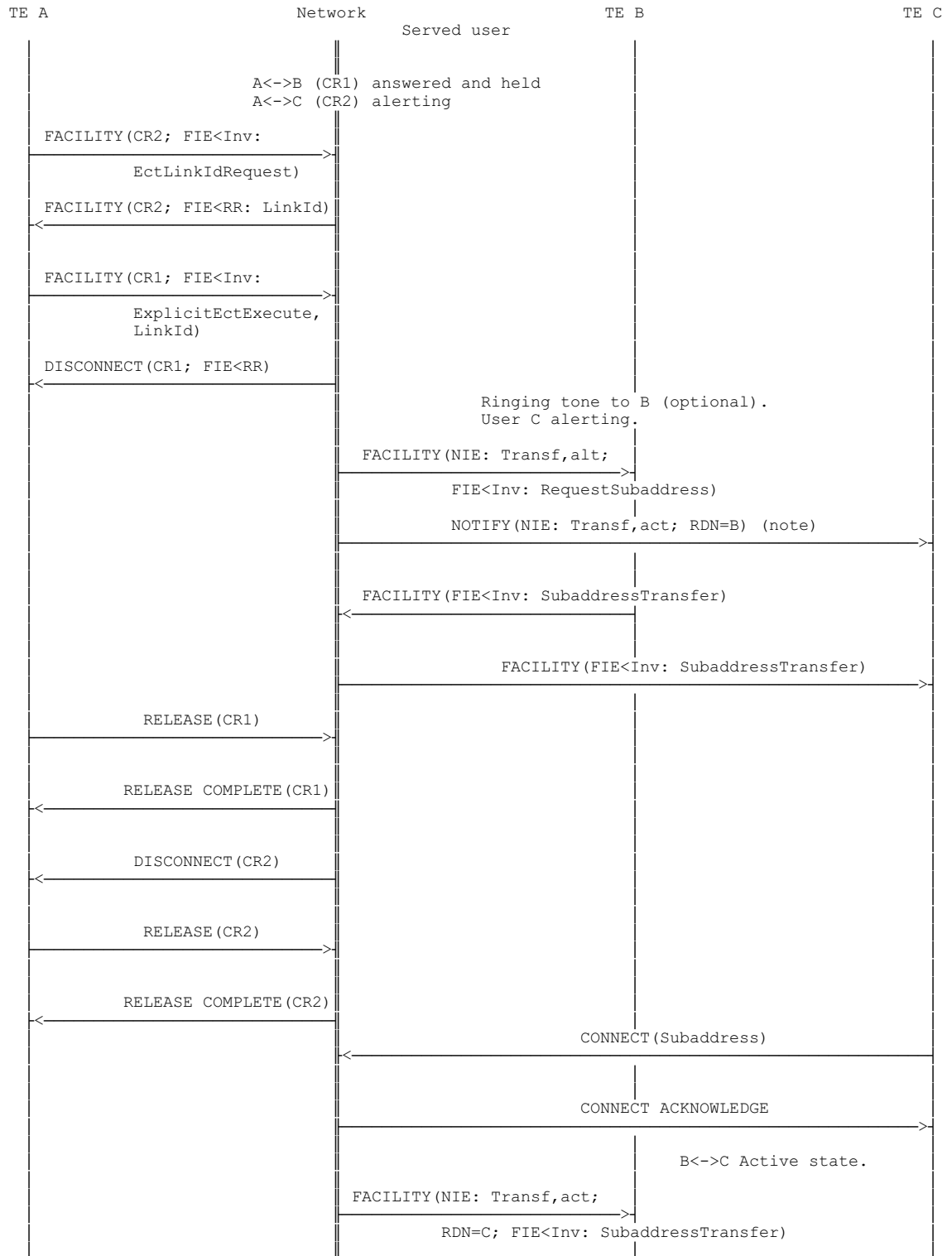

Figure A.5: ECT explicit invocation - LinkId request fails



NOTE: RDN included if allowed, see tables 5 to 8.

Figure A.6: ECT explicit invocation - Transfer after answer



NOTE: RDN included if allowed, see tables 5 to 8.

Figure A.7: ECT explicit invocation - Transfer while alerting

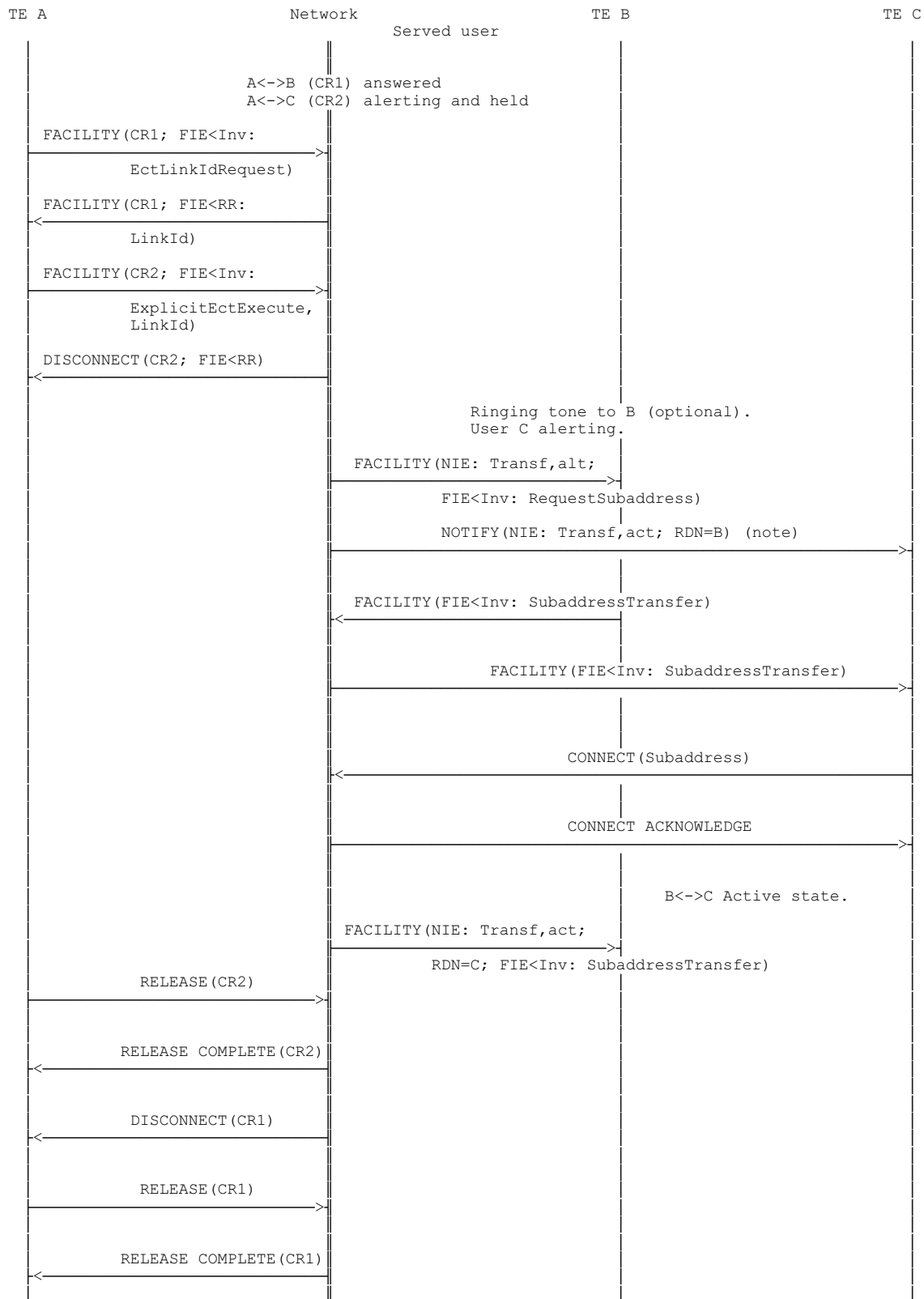

NOTE: RDN included if allowed, see tables 5 to 8.

Figure A.8: ECT explicit invocation - Transfer while alerting

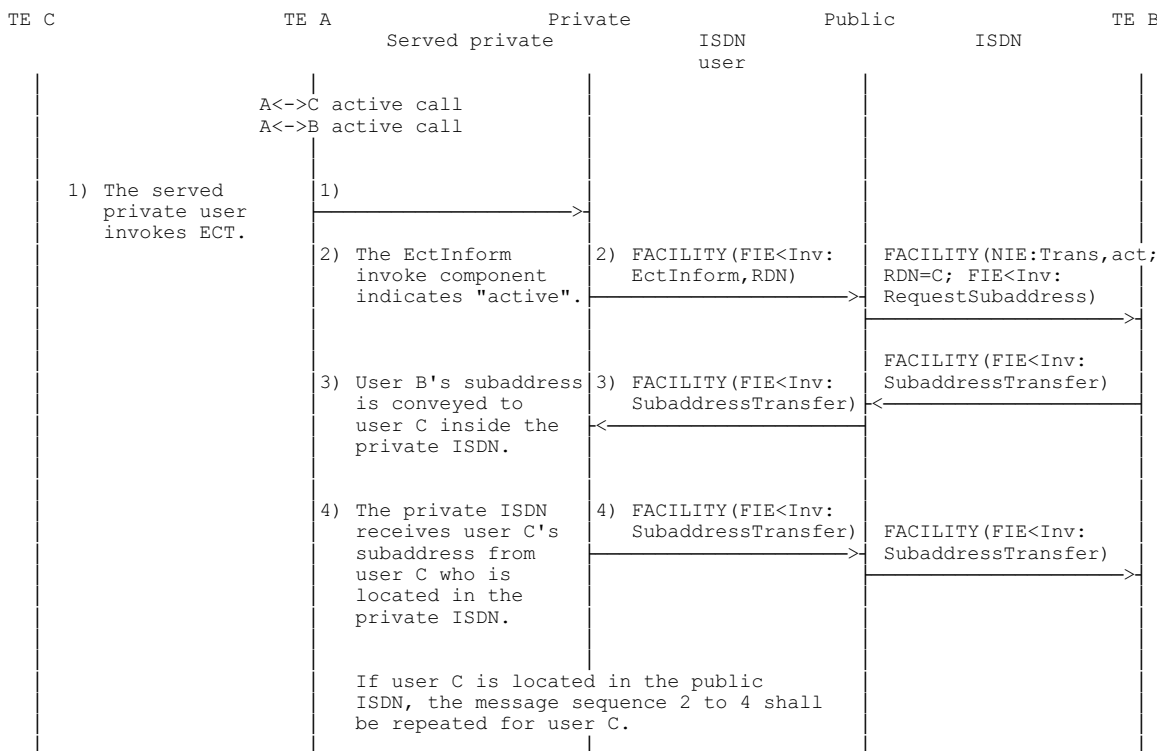

Figure A.9: Served user in a private ISDN

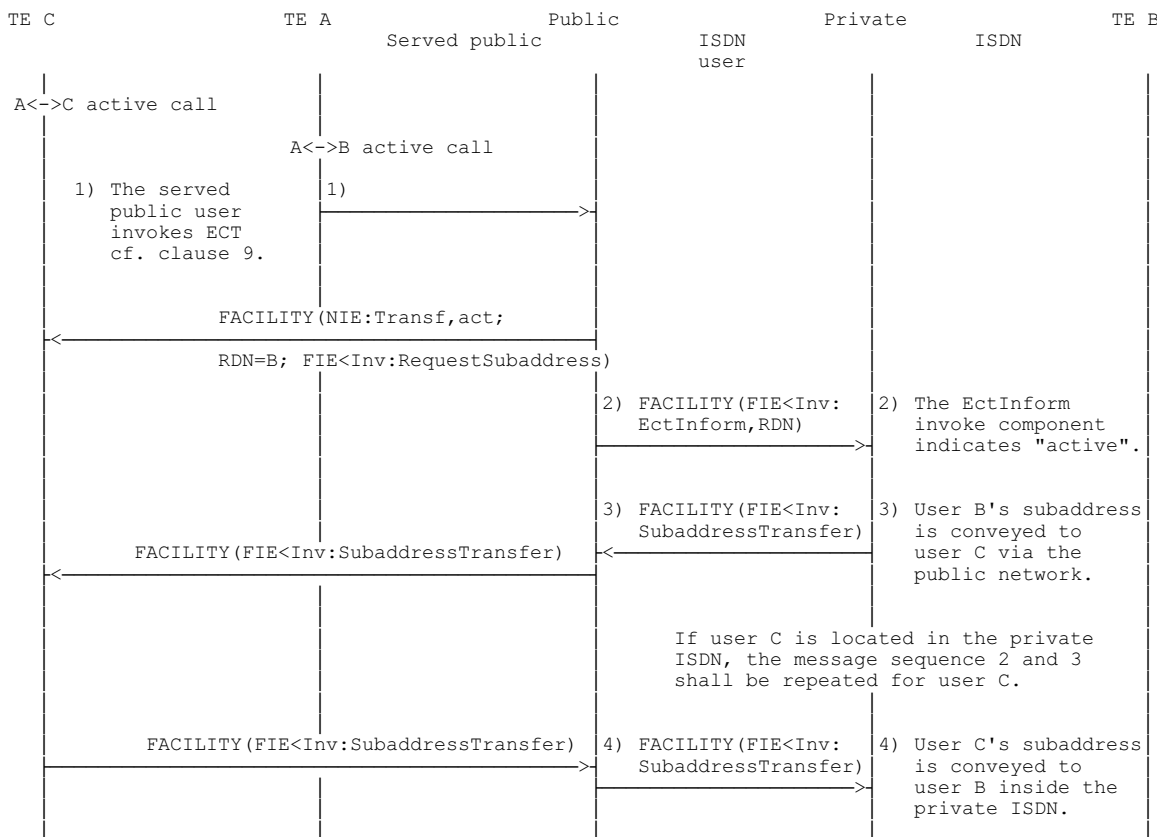

Figure A.10: Remote user in a private ISDN

Annex B (informative): Assignment of object identifier values

The following object identifier values are assigned in this ETS:

{ccitt identified-organization etsi(0) 369 operations-and-errors(1)}

{ccitt identified-organization etsi(0) 369 operations-and-errors(1) explicitEctExecute-operation(1)}

{ccitt identified-organization etsi(0) 369 operations-and-errors(1) requestSubaddress-operation(2)}

{ccitt identified-organization etsi(0) 369 operations-and-errors(1) subaddressTransfer-operation(3)}

{ccitt identified-organization etsi(0) 369 operations-and-errors(1) ectLinkIdRequest-operation(4)}

{ccitt identified-organization etsi(0) 369 operations-and-errors(1) ectInform-operation(5)}

{ccitt identified-organization etsi(0) 369 operations-and-errors(1) ectLoopTest-operation(6)}

{ccitt identified-organization etsi(0) 369 operations-and-errors(1) linkIdNotAssignedByNetwork-error(21)}

History

Document history	
March 1994	Public Enquiry PE 58: 1994-03-07 to 1994-07-01
March 1995	Vote V 75: 1995-03-06 to 1995-04-28
May 1995	First Edition
January 1996	Converted into Adobe Acrobat Portable Document Format (PDF)