



EUROPEAN
TELECOMMUNICATION
STANDARD

ETS 300 368

May 1995

Source: ETSI TC-SPS

Reference: T/S 22-21,1

ICS: 33.080

Key words: ISDN, supplementary service

**Integrated Services Digital Network (ISDN);
Explicit Call Transfer (ECT) supplementary service
Functional capabilities and information flows**

ETSI

European Telecommunications Standards Institute

ETSI Secretariat

Postal address: F-06921 Sophia Antipolis CEDEX - FRANCE

Office address: 650 Route des Lucioles - Sophia Antipolis - Valbonne - FRANCE

X.400: c=fr, a=atlas, p=etsi, s=secretariat - **Internet:** secretariat@etsi.fr

Tel.: +33 92 94 42 00 - Fax: +33 93 65 47 16

Copyright Notification: No part may be reproduced except as authorized by written permission. The copyright and the foregoing restriction extend to reproduction in all media.

© European Telecommunications Standards Institute 1995. All rights reserved.

Contents

Foreword.....	5
1 Scope	7
2 Normative references	7
3 Definitions.....	8
4 Abbreviations	8
5 Description	9
6 Derivation of the functional model	9
6.1 Functional model description	9
6.2 Description of the FEs	9
6.3 Relationship with a basic service	10
7 Information flows.....	10
7.1 Information flow diagrams.....	10
7.2 Definition of the individual information flows	13
7.2.1 Relationship rq.....	13
7.2.1.1 Contents of TRANSFER INVOKE.....	13
7.2.2 Relationship rr.....	13
7.2.2.1 Contents of TRANSFER INVOKE.....	13
7.2.3 Relationship rs1	14
7.2.3.1 Contents of TRANSFER COMPLETE.....	14
7.2.3.2 Contents of TRANSFER ACTIVE	14
7.2.3.3 Contents of LOOP TEST.....	14
7.2.3.4 Contents of LOOP TEST REJECT	14
7.2.4 Relationship rs2	14
7.2.4.1 Contents of TRANSFER COMPLETE.....	14
7.2.4.2 Contents of TRANSFER ACTIVE	15
7.2.4.3 Contents of TERMINAL DETAILS	15
7.2.4.4 Contents of LOOP TEST.....	15
7.2.4.5 Contents of LOOP TEST REJECT	15
7.2.5 Relationship rt.....	16
7.2.5.1 Contents of TRANSFER INFORM.....	16
7.2.5.2 Contents of TERMINAL DETAILS	16
7.2.6 Relationship ru	16
7.2.6.1 Contents of TERMINAL DETAILS	16
8 SDL diagrams for FEs	16
8.1 FE1.....	17
8.2 FE2.....	19
8.3 FE3.....	20
8.4 FE4.....	24
8.5 FE5.....	27
8.6 FE6.....	30
9 Functional Entity Actions (FEAs).....	31
9.1 FEAs of FE1.....	31
9.2 FEAs of FE2.....	31
9.3 FEAs of FE3.....	31
9.4 FEAs of FE4.....	32

9.5	FEAs of FE5.....	33
9.6	FEAs of FE6.....	33
10	Allocation of FEs to physical locations.....	34
	History	35

Foreword

This European Telecommunication Standard (ETS) has been produced by the Signalling Protocols and Switching (SPS) Technical Committee of the European Telecommunications Standards Institute (ETSI).

In accordance with CCITT Recommendation I.130, the following three level structure is used to describe the supplementary telecommunication services as provided by European public telecommunications operators under the pan-European Integrated Services Digital Network (ISDN):

- Stage 1: is an overall service description, from the user's standpoint;
- Stage 2: identifies the functional capabilities and information flows needed to support the service described in stage 1; and
- Stage 3: defines the signalling system protocols and switching functions needed to implement the service described in stage 1.

This ETS details the stage 2 aspects (functional capabilities and information flows) needed to support the Explicit Call Transfer (ECT) supplementary service. The stage 1 and stage 3 aspects are detailed in ETS 300 367 and ETS 300 369-1, respectively.

Transposition dates	
Date of latest announcement of this ETS (doa):	31 August 1995
Date of latest publication of new National Standard or endorsement of this ETS (dop/e):	29 February 1996
Date of withdrawal of any conflicting National Standard (dow):	29 February 1996

Blank page

1 Scope

This European Telecommunication Standard (ETS) defines the stage two description of the Explicit Call Transfer (ECT) supplementary service for the pan-European Integrated Services Digital Network (ISDN) as provided by European public telecommunications operators. Stage two identifies the functional capabilities and the information flows needed to support the service description as described in stage one. The stage two description also identifies user operations not directly associated with a call (see CCITT Recommendation 1.130 [2]).

This ETS is specified according to the methodology specified in CCITT Recommendation Q.65 [3].

This ETS does not formally describe the relationship between this supplementary service and the basic call, but where possible this information is included for guidance.

In addition this ETS does not specify the requirements where the service is provided to the user via a private ISDN. This ETS does not specify the requirements for the allocation of defined Functional Entities (FEs) within a private ISDN; it does, however, define which functional entities may be allocated to a private ISDN.

This ETS does not specify the additional requirements where the service is provided to the user via a telecommunications network that is not an ISDN.

The ECT supplementary service enables a user who has two calls, each of which can be an incoming or an outgoing call, to connect the other users in the two calls.

The ECT supplementary service is applicable to all circuit-switched telecommunication services.

This ETS is applicable to the stage three standards for the ISDN ECT supplementary service. The term "stage three" is also defined in CCITT Recommendation 1.130 [2]. Where the text indicates the status of a requirement, i.e. as strict command or prohibition, as authorization leaving freedom, as a capability or possibility, this shall be reflected in the text of the relevant stage two and stage three standards.

Furthermore, conformance to this ETS is met by conforming to the stage three standards with the field of application appropriate to the equipment being implemented. Therefore, no method of testing is provided for this ETS.

2 Normative references

This ETS incorporates by dated or undated reference, provisions from other publications. These normative references are cited at the appropriate places in the text and the publications are listed hereafter. For dated references, subsequent amendments to or revisions of any of these publications apply to this ETS only when incorporated in it by amendment or revision. For undated references the latest edition of the publication referred to applies.

- [1] ITU-T Recommendation I.112 (1993): "Vocabulary of terms for ISDNs".
- [2] CCITT Recommendation I.130 (1988): "Method for the characterization of telecommunication services supported by an ISDN and network capabilities of an ISDN".
- [3] CCITT Recommendation Q.65 (1988): "Stage 2 of the method for the characterization of services supported by an ISDN".
- [4] CCITT Recommendation Q.71 (1988): "ISDN 64 kbit/s circuit mode switched bearer service".
- [5] CCITT Recommendation Z.100 (1988): "Specification and Description Language".

3 Definitions

For the purposes of this ETS, the following definitions apply:

Integrated Services Digital Network (ISDN): See ITU-T Recommendation I.112 [1], definition 308.

primary call: One of user A's (answered) calls.

secondary call: The other user A call (answered or alerting).

service; telecommunication service: See ITU-T Recommendation I.112 [1], definition 201.

transfer by join: The effecting of transfer by joining together the primary and secondary calls at user A's local exchange.

transfer by rerouting: The effecting of transfer by establishing a new connection to replace the primary and secondary calls.

user A: The served user, i.e. the user requesting the ECT supplementary service.

user B: The other user in user A's primary call.

user C: The other user in user A's secondary call.

4 Abbreviations

For the purposes of this ETS, the following abbreviations apply:

CC	Call Control
CCA	Call Control Agent
ECT	Explicit Call Transfer
FE	Functional Entity
FEA	Functional Entity Action
ISDN	Integrated Services Digital Network
LE	Local Exchange
PTNX	Private Telecommunication Network eXchange
SDL	Specification and Description Language
TE	Terminal Equipment

5 Description

This stage two supports only one variant of the ECT supplementary service, that of transfer by join. The functional model supports interworking with transfer by rerouting, which may occur within a private network but involving users of a public network.

Table 1 shows the states for the invocation of the ECT supplementary service.

Table 1: States for invocation of ECT

Primary call	Secondary call
Active, held	Active, idle
Active, held	Alerting, idle (note)
Active, idle	Alerting, held (note)
NOTE: Only applicable for an outgoing call.	

The procedures are currently restricted to basic telecommunication services involving a single 64 kbit/s connection. This ETS is not applicable to a video telephony call involving two 64 kbit/s connections.

6 Derivation of the functional model

6.1 Functional model description

The functional model for the ECT supplementary service is shown in figure 1.

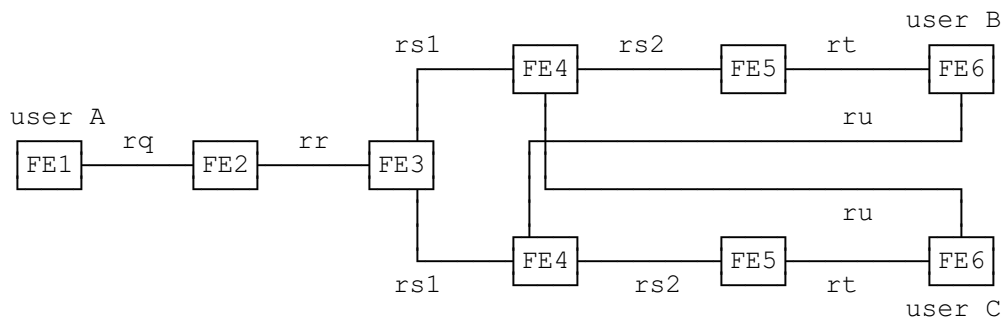

Figure 1: Functional model for the ECT supplementary service

6.2 Description of the FEs

The FEs required by the ECT supplementary service in addition to those of basic call are as follows:

- FE1: Transfer invoke entity;
- FE2: Transfer validate entity;
- FE3: Transfer execute entity;
- FE4: Transfer screen entity;
- FE5: Transfer complete receive entity;
- FE6: Transfer inform receive entity.

6.3 Relationship with a basic service

The relationship with a basic service is as shown in figure 2.

NOTE: The basic call model is defined in CCITT Recommendation Q.71 [4], § 2.1, with the exception that r1 represents an outgoing call relationship from a Call Control Agent (CCA) and r3 represents an incoming call relationship to a CCA.

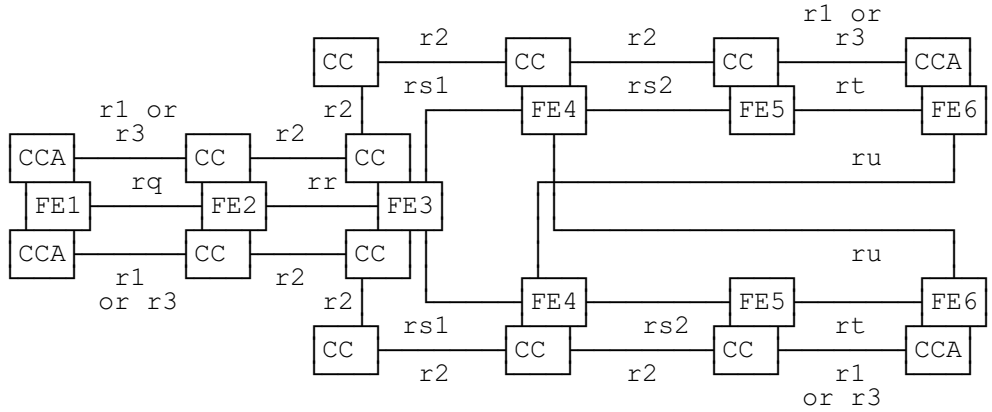

Figure 2: Relationship to basic call

7 Information flows

7.1 Information flow diagrams

The information flow diagrams assume the existence of a primary call and a secondary call and that both calls are maintained until the completion of the transfer. Clearing of the primary and secondary calls with respect to the served user is not shown as this uses basic call information flows only. Similarly any information flows concerned with holding and retrieving the primary and secondary calls are outside the scope of this ETS.

The TERMINAL DETAILS information flow may occur between both FE6s. Where there is no information to be sent at all, the information flow is not present in either direction. The information flow is only shown in one direction in figure 3 for reasons of clarity.

The TRANSFER ACTIVE information flow will only occur in the case of an alerting transfer where the alerting user subsequently answers. In such a case, a TERMINAL DETAILS information flow from user B's FE6 may also occur as a result of receiving the second TRANSFER INFORM indication.

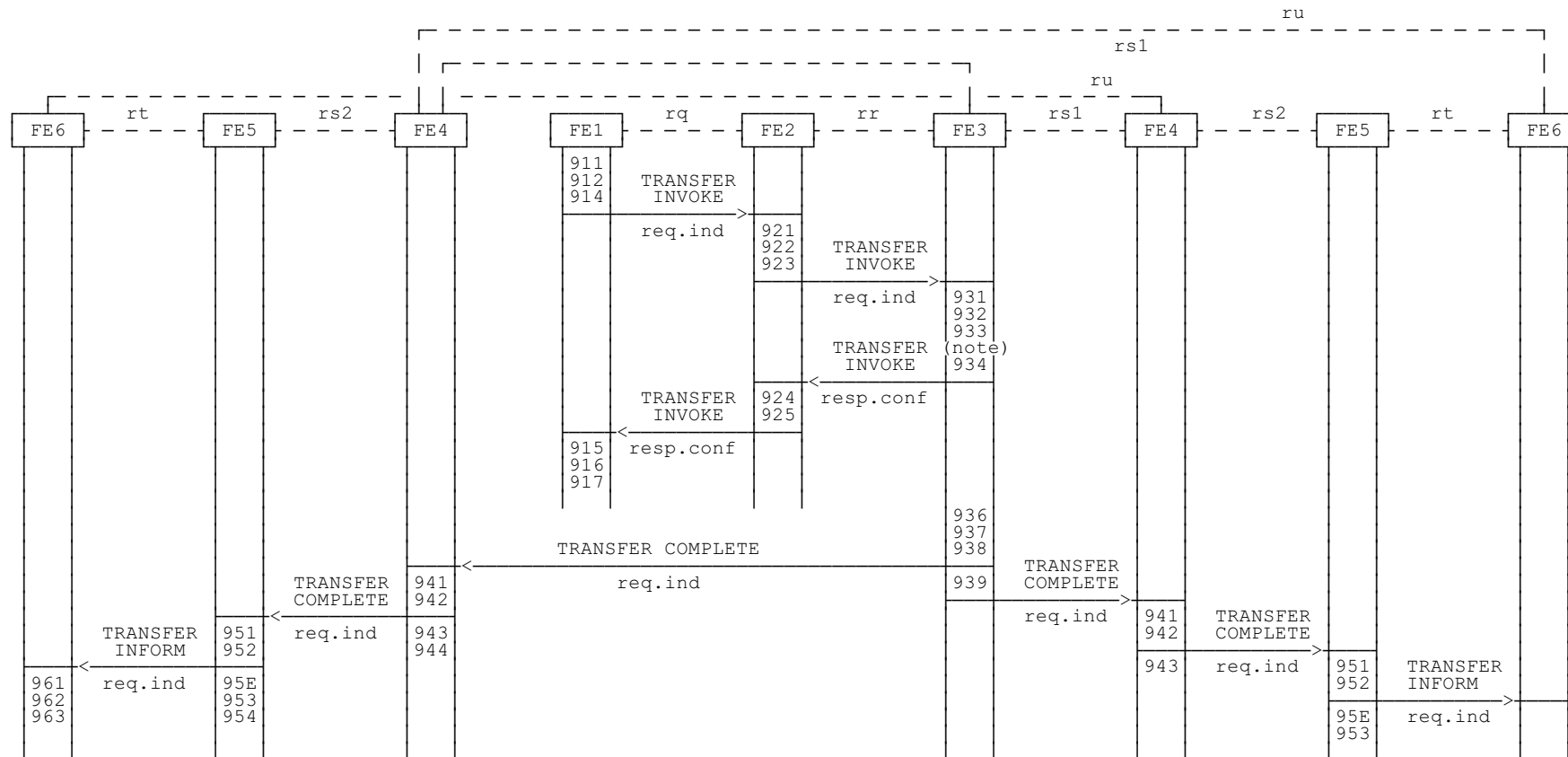

NOTE: If the optional procedures for preventing loops are provided, the information flow shown in figure 4 occurs at this point, before proceeding with the rest of the information flow shown in this figure.

Figure 3 (sheet 1 of 2): Successful call transfer

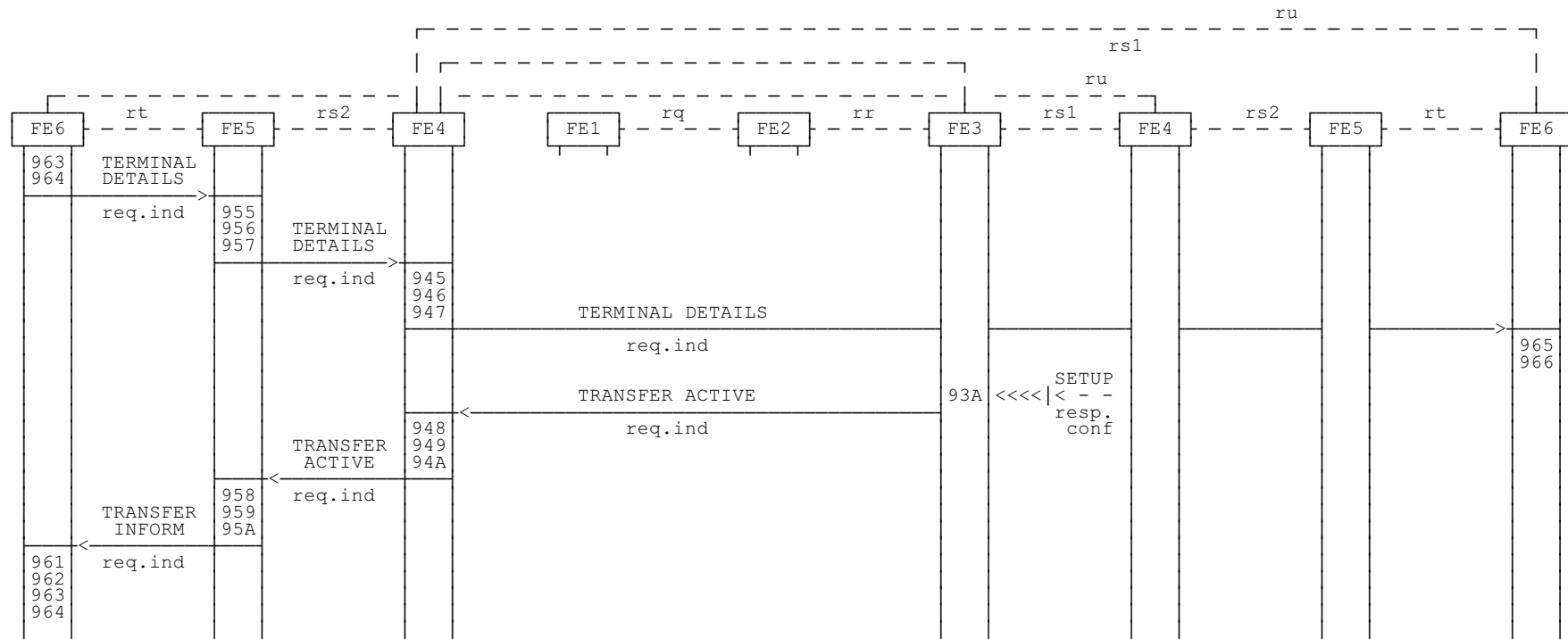

Figure 3 (sheet 2 of 2): Successful call transfer

Figure 4 shows the optional procedure for preventing loops.

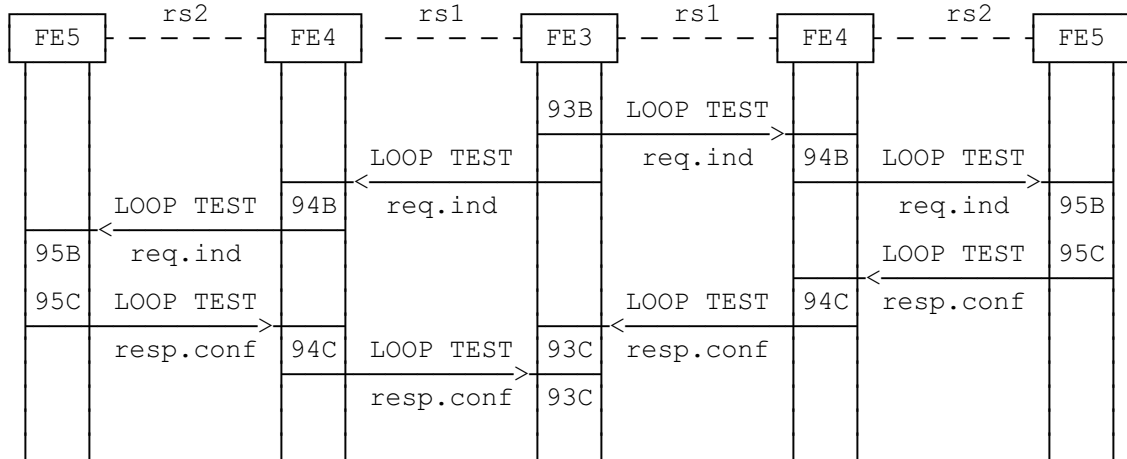

Figure 4: Optional loop test procedure

7.2 Definition of the individual information flows

7.2.1 Relationship rq

7.2.1.1 Contents of TRANSFER INVOKE

This confirmed information flow initiates a transfer. It contains the identities of the calls involving user B and user C.

The contents of the TRANSFER INVOKE req.ind and TRANSFER INVOKE resp.conf information flows are shown in table 2.

Table 2: TRANSFER INVOKE

Name	req.ind	resp.conf
Call identities	M	-
Transfer result	-	M

7.2.2 Relationship rr

7.2.2.1 Contents of TRANSFER INVOKE

This confirmed information flow requests execution of a transfer. It contains the identities of the calls involving user B and user C.

The contents of the TRANSFER INVOKE req.ind and TRANSFER INVOKE resp.conf information flows are shown in table 3.

Table 3: TRANSFER INVOKE

Name	req.ind	resp.conf
Call identities	M	-
Transfer result	-	M

7.2.3 Relationship rs1

7.2.3.1 Contents of TRANSFER COMPLETE

This unconfirmed information flow indicates that a transfer has been effected.

The contents of the TRANSFER COMPLETE req.ind information flow are shown in table 4.

Table 4: TRANSFER COMPLETE

Name	req.ind
Transferred number	O (note 1)
Alerting indication	O (note 2)
NOTE 1: Mandatory if known.	
NOTE 2: Mandatory if the other user is being alerted.	

7.2.3.2 Contents of TRANSFER ACTIVE

This unconfirmed information flow indicates that answer has taken place subsequent to an alerting transfer. The contents are the same as those of a basic call SETUP resp.conf.

7.2.3.3 Contents of LOOP TEST

This confirmed information flow indicates that a loop test has been invoked.

There are no contents of the LOOP TEST req.ind or LOOP TEST resp.conf information flows.

7.2.3.4 Contents of LOOP TEST REJECT

This unconfirmed information flow indicates that a loop test has failed.

The contents of the LOOP TEST REJECT req.ind information flow is shown in table 5.

Table 5: Contents of LOOP TEST REJECT

Name	req.ind
Reason	M

7.2.4 Relationship rs2

7.2.4.1 Contents of TRANSFER COMPLETE

This unconfirmed information flow indicates that a transfer has been effected.

The contents of the TRANSFER COMPLETE req.ind information flow are shown in table 6.

Table 6: TRANSFER COMPLETE

Name	req.ind
Transferred number	O (note 1)
Transferred subaddress	O (note 2)
Alerting indication	O (note 3)
NOTE 1:	Mandatory if known and not restricted.
NOTE 2:	Mandatory if transfer occurs with the other user alerting, and if the TRANSFER INFORM req.ind is being sent as a result of the answer to the alerting call, and if the subaddress is known and not restricted. Otherwise, the information shall not be sent.
NOTE 3:	Mandatory if the other user is being alerted.

7.2.4.2 Contents of TRANSFER ACTIVE

This unconfirmed information flow indicates that answer has taken place subsequent to an alerting transfer. The contents are the same as those of a basic call SETUP resp.conf.

7.2.4.3 Contents of TERMINAL DETAILS

This unconfirmed information flow informs users of any subaddress associated with the other user involved in the transfer.

The contents of the TERMINAL DETAILS req.ind information flow are shown in table 7.

Table 7: TERMINAL DETAILS

Name	req.ind
Transferred subaddress	M

7.2.4.4 Contents of LOOP TEST

This confirmed information flow indicates that a loop test has been invoked.

There are no contents of the LOOP TEST req.ind or LOOP TEST resp.conf information flows.

7.2.4.5 Contents of LOOP TEST REJECT

This unconfirmed information flow indicates that a loop test has failed.

The contents of the LOOP TEST REJECT req.ind information flow are shown in table 8.

Table 8: Contents of LOOP TEST REJECT

Name	req.ind
Reason	M

7.2.5 Relationship rt

7.2.5.1 Contents of TRANSFER INFORM

This unconfirmed information flow informs users of the successful completion of a call transfer, and the identity of the other user.

The contents of the TRANSFER INFORM req.ind information flow are shown in table 9.

Table 9: TRANSFER INFORM

Name	req.ind
Transferred number	O (note 1)
Alerting indication	O (note 2)
NOTE 1: Mandatory if known and not restricted.	
NOTE 2: Mandatory if the other user is being alerted.	

7.2.5.2 Contents of TERMINAL DETAILS

This unconfirmed information flow informs users of any subaddress associated with the other user involved in the transfer.

The contents of the TERMINAL DETAILS req.ind information flow are shown in table 10.

Table 10: TERMINAL DETAILS

Name	req.ind
Transferred subaddress	M

7.2.6 Relationship ru

7.2.6.1 Contents of TERMINAL DETAILS

This unconfirmed information flow informs users of any subaddress associated with the other user involved in the transfer.

The contents of the TERMINAL DETAILS req.ind information flow are shown in table 11.

Table 11: TERMINAL DETAILS

Name	req.ind
Transferred subaddress	M

8 SDL diagrams for FEs

The Specification and Description Language (SDL) diagrams are provided according to CCITT Recommendation Z.100 [5].

8.1 FE1

The SDL diagram for FE1 is shown in figure 5.

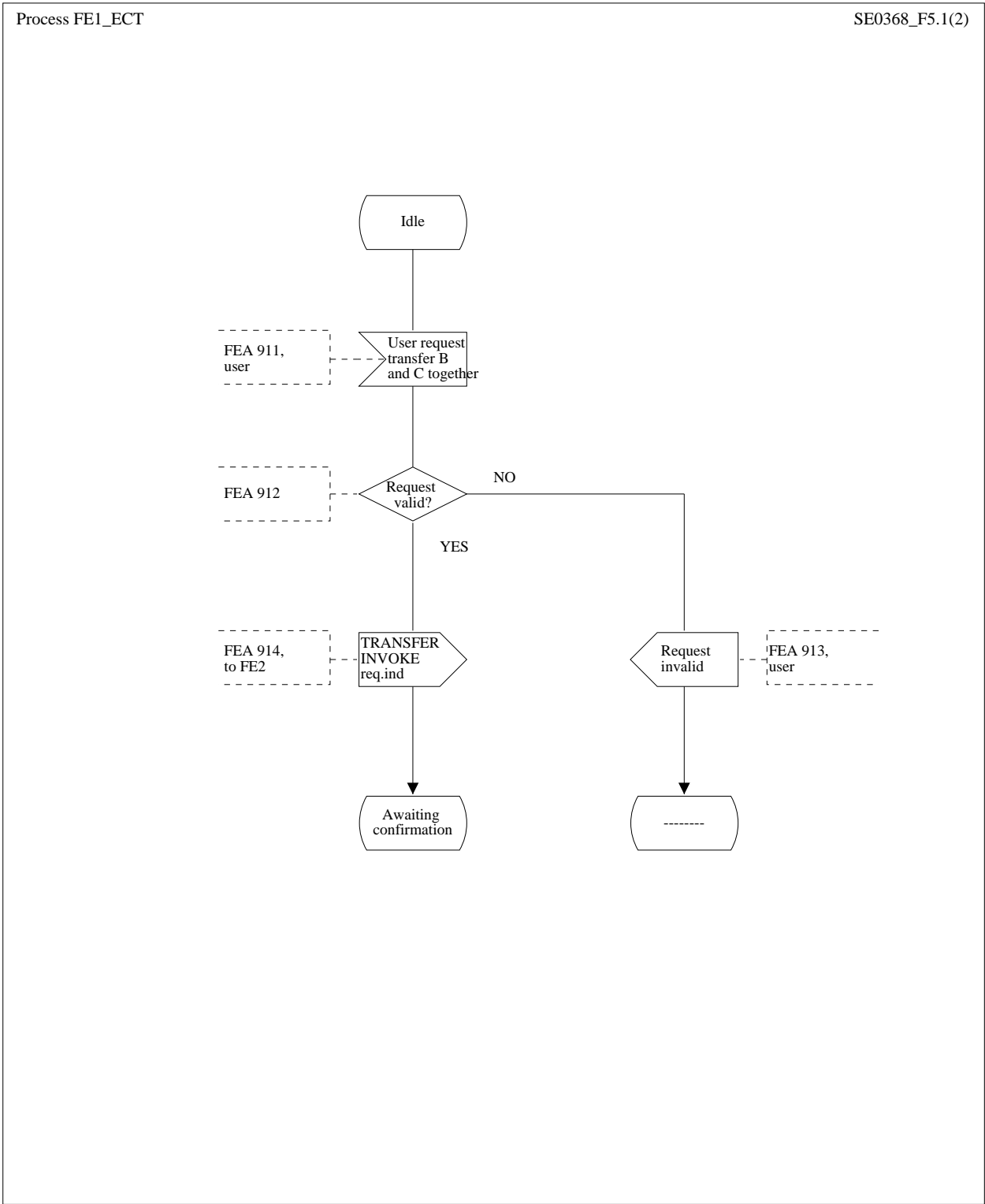

Figure 5 (sheet 1 of 2): SDL diagram for FE1

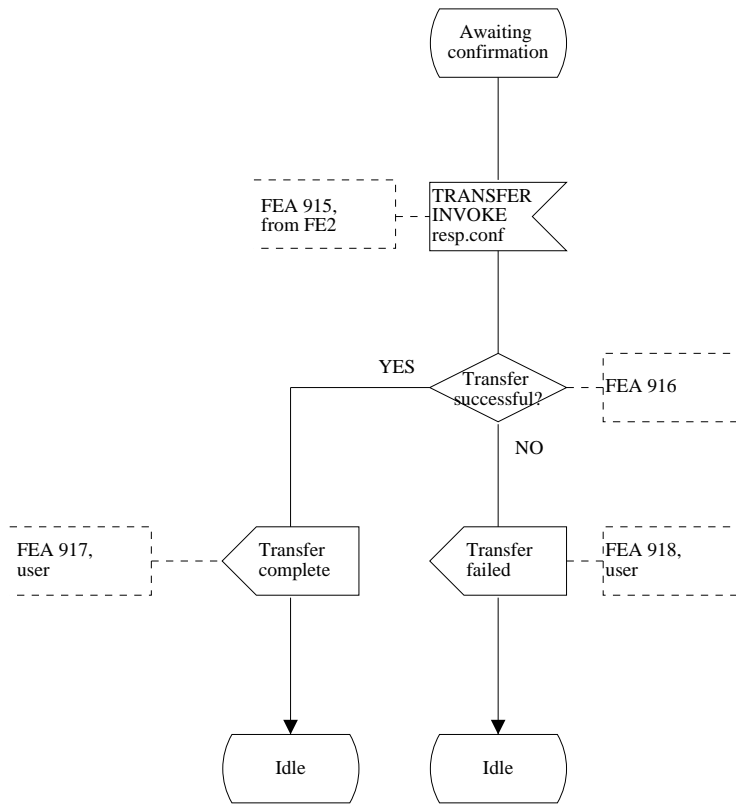

Figure 5 (sheet 2 of 2): SDL diagram for FE1

8.2 FE2

The SDL diagram for FE2 is shown in figure 6.

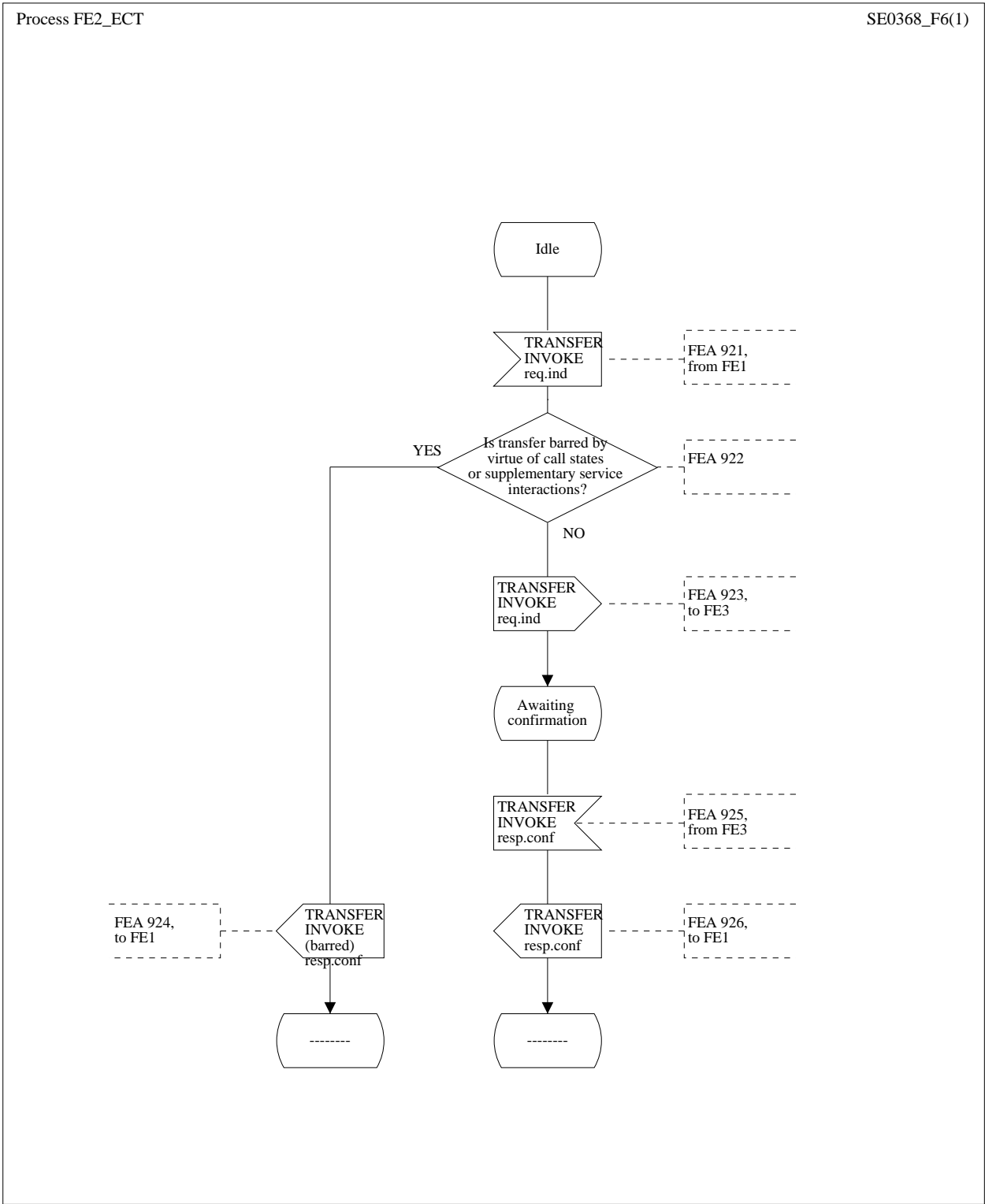

Figure 6: SDL diagram for FE2

8.3 FE3

The SDL diagram for FE3 is shown in figure 7.

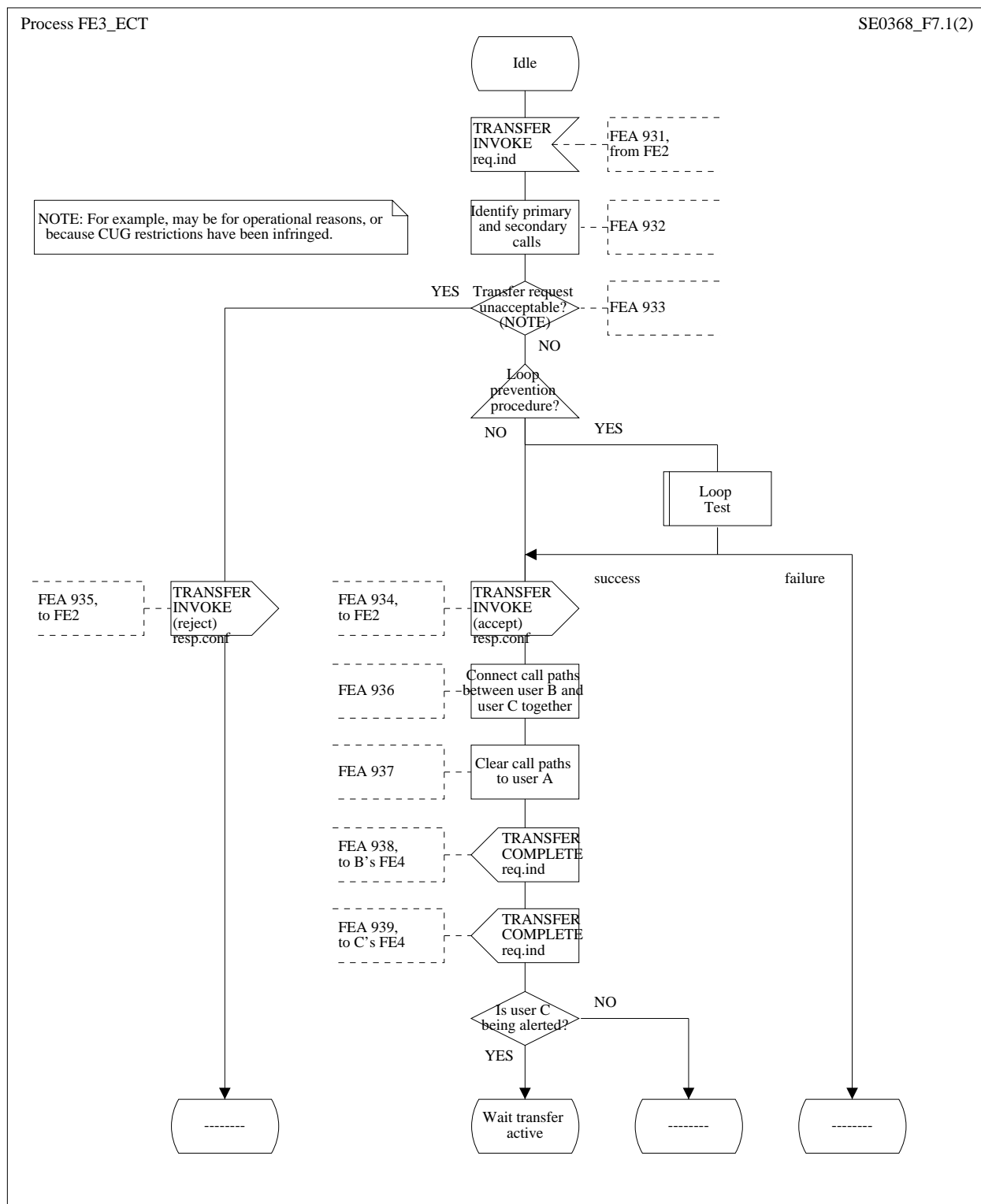

Figure 7 (sheet 1 of 4): SDL diagram for FE3

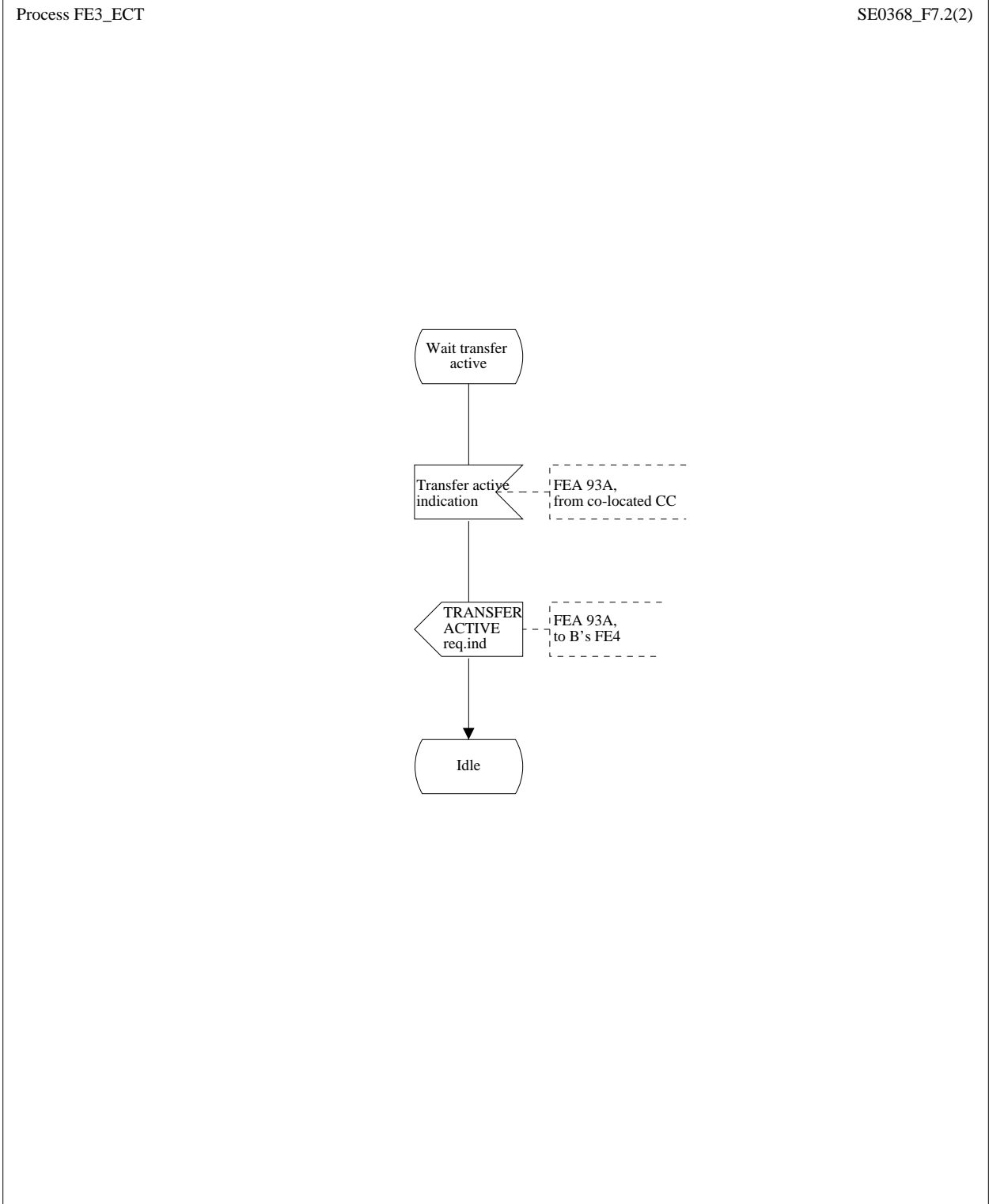

Figure 7 (sheet 2 of 4): SDL diagram for FE3

Macro Loop_Test

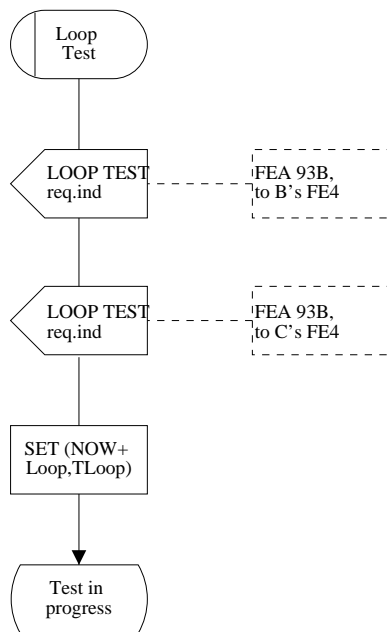

Figure 7 (sheet 3 of 4): SDL diagram for FE3

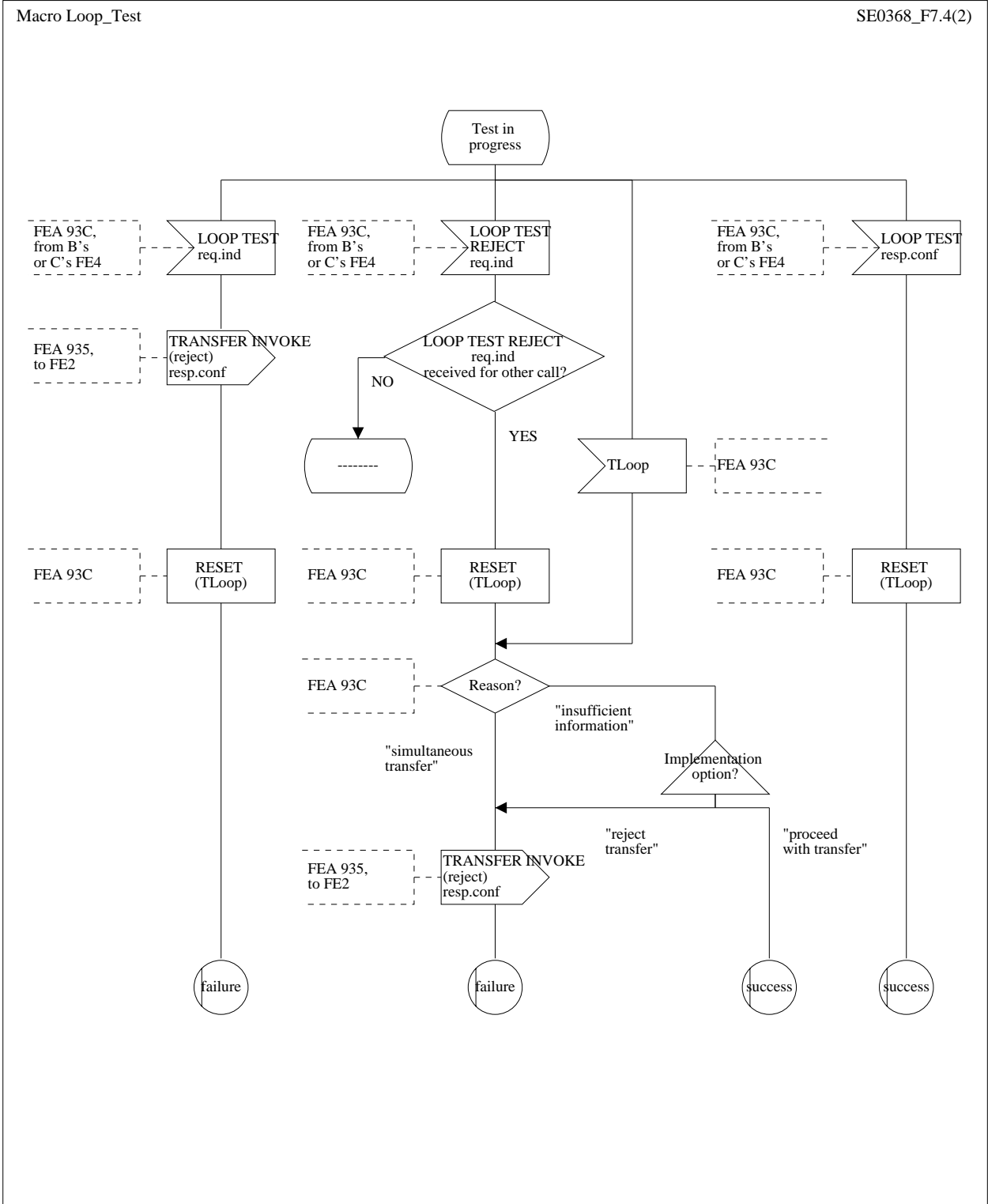

Figure 7 (sheet 4 of 4): SDL diagram for FE3

8.4 FE4

The SDL diagram for FE4 is shown in figure 8.

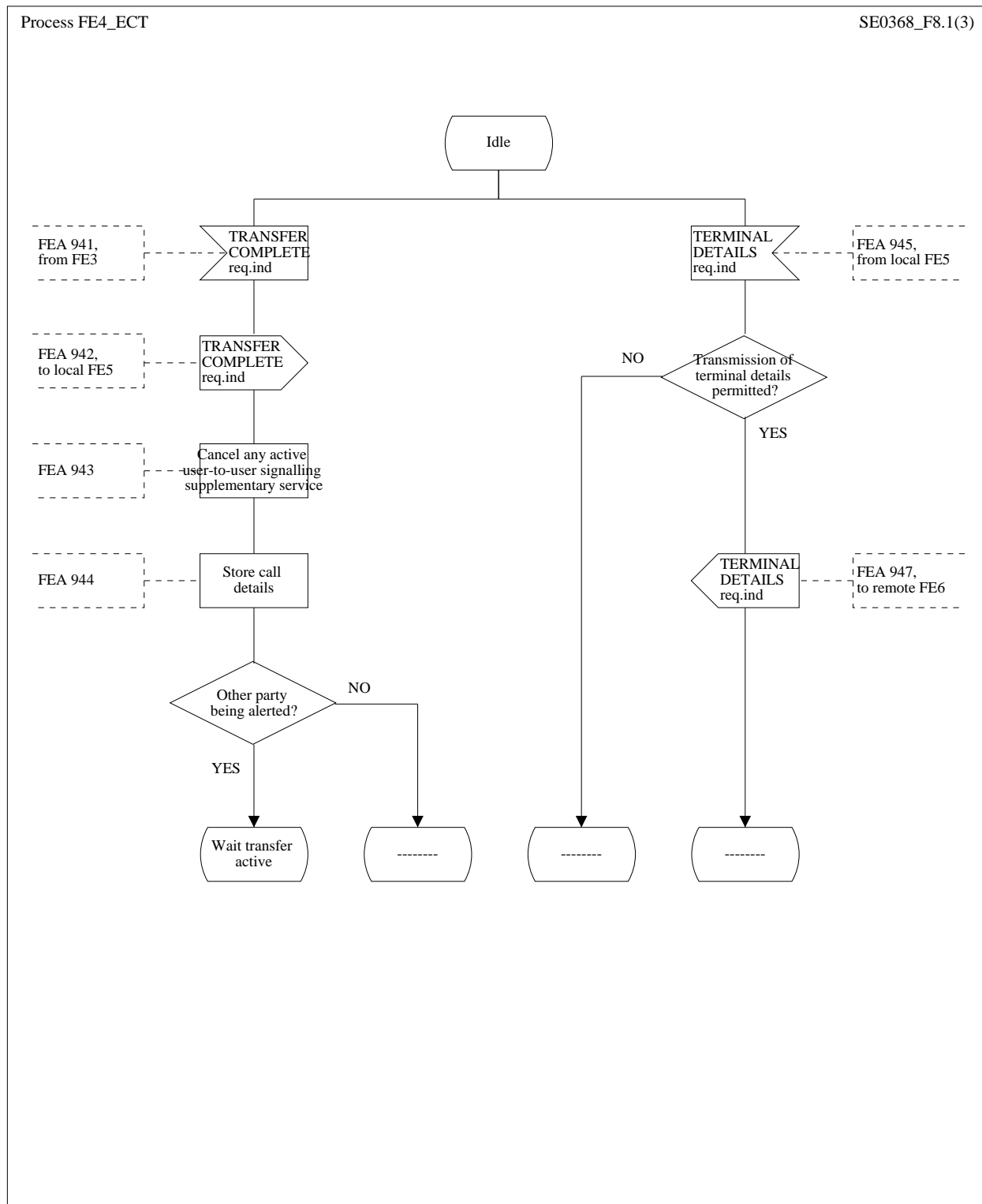

Figure 8 (sheet 1 of 3): SDL diagram for FE4

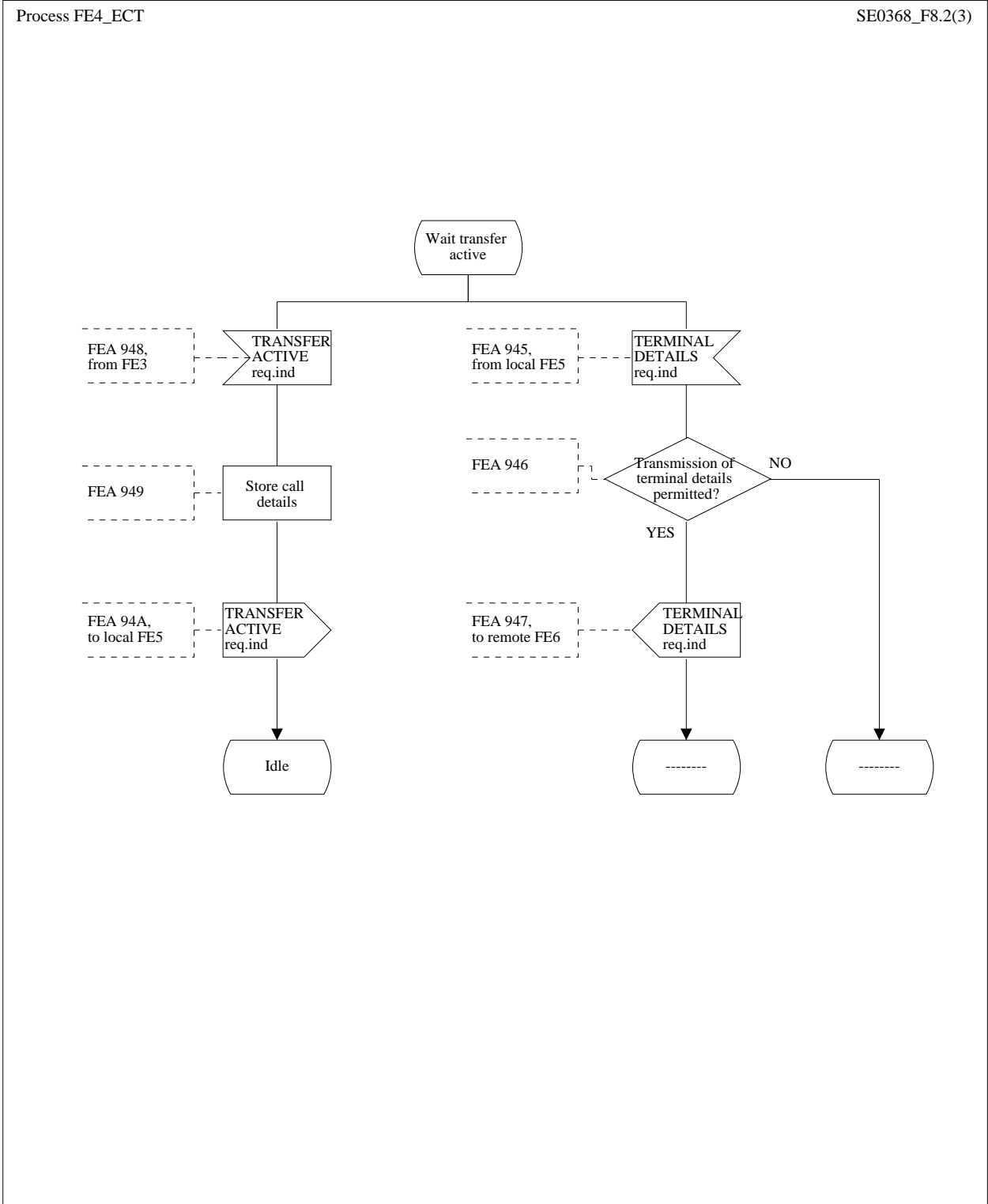

Figure 8 (sheet 2 of 3): SDL diagram for FE4

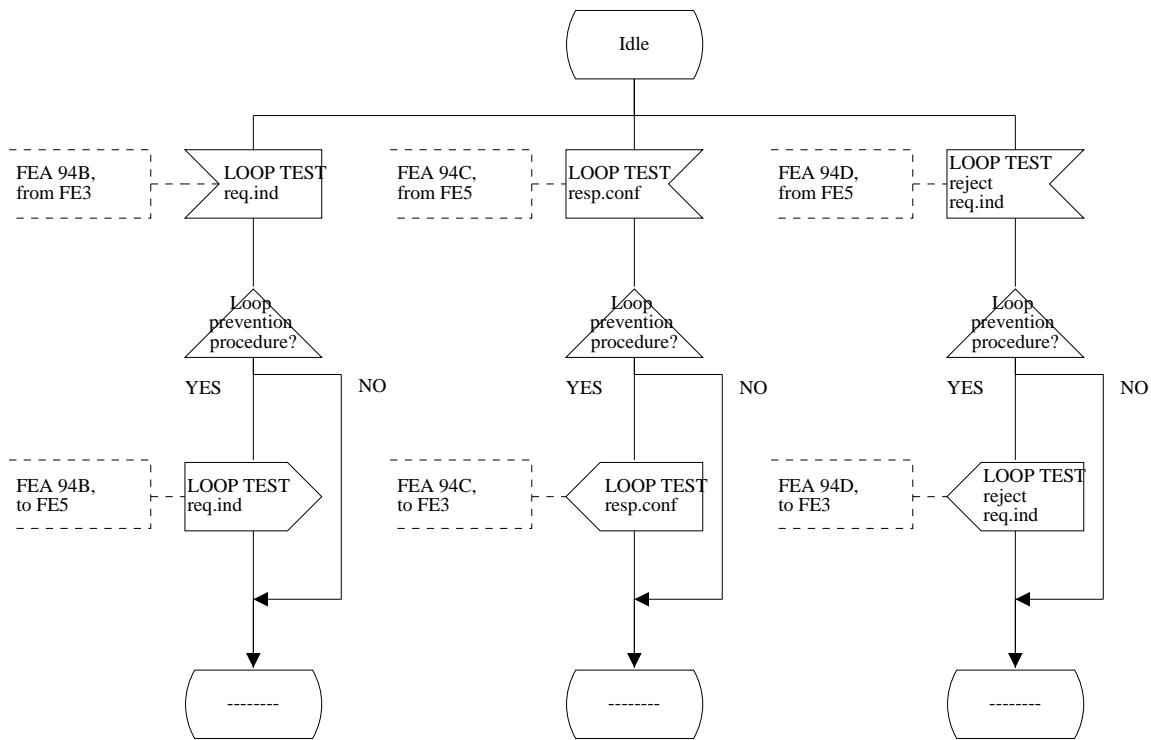

Figure 8 (sheet 3 of 3): SDL diagram for FE4

8.5 FE5

The SDL diagram for FE5 is shown in figure 9.

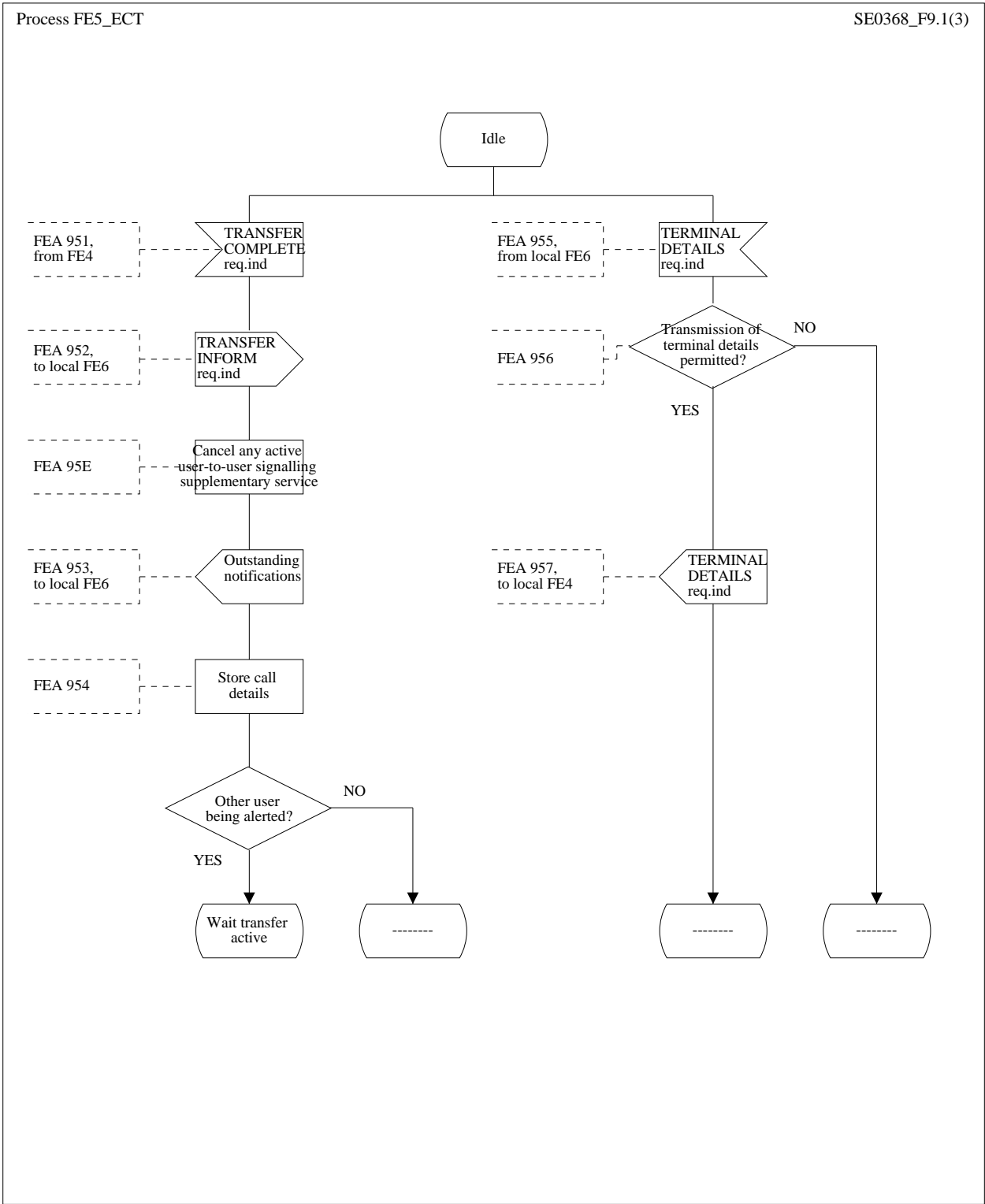

Figure 9 (sheet 1 of 3): SDL diagram for FE5

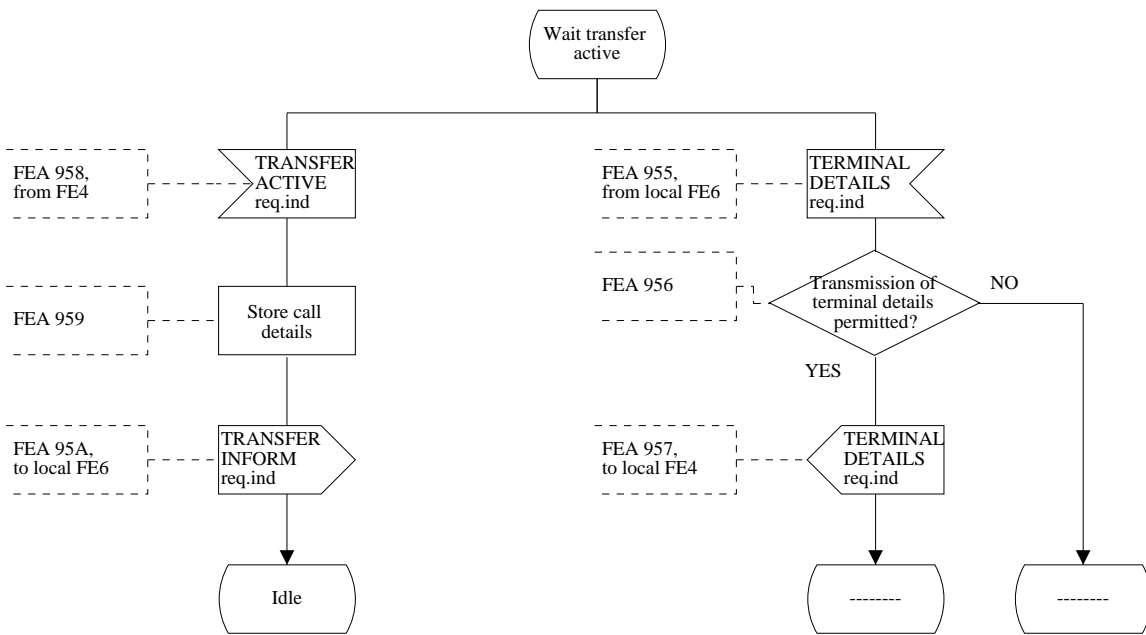

Figure 9 (sheet 2 of 3): SDL diagram for FE5

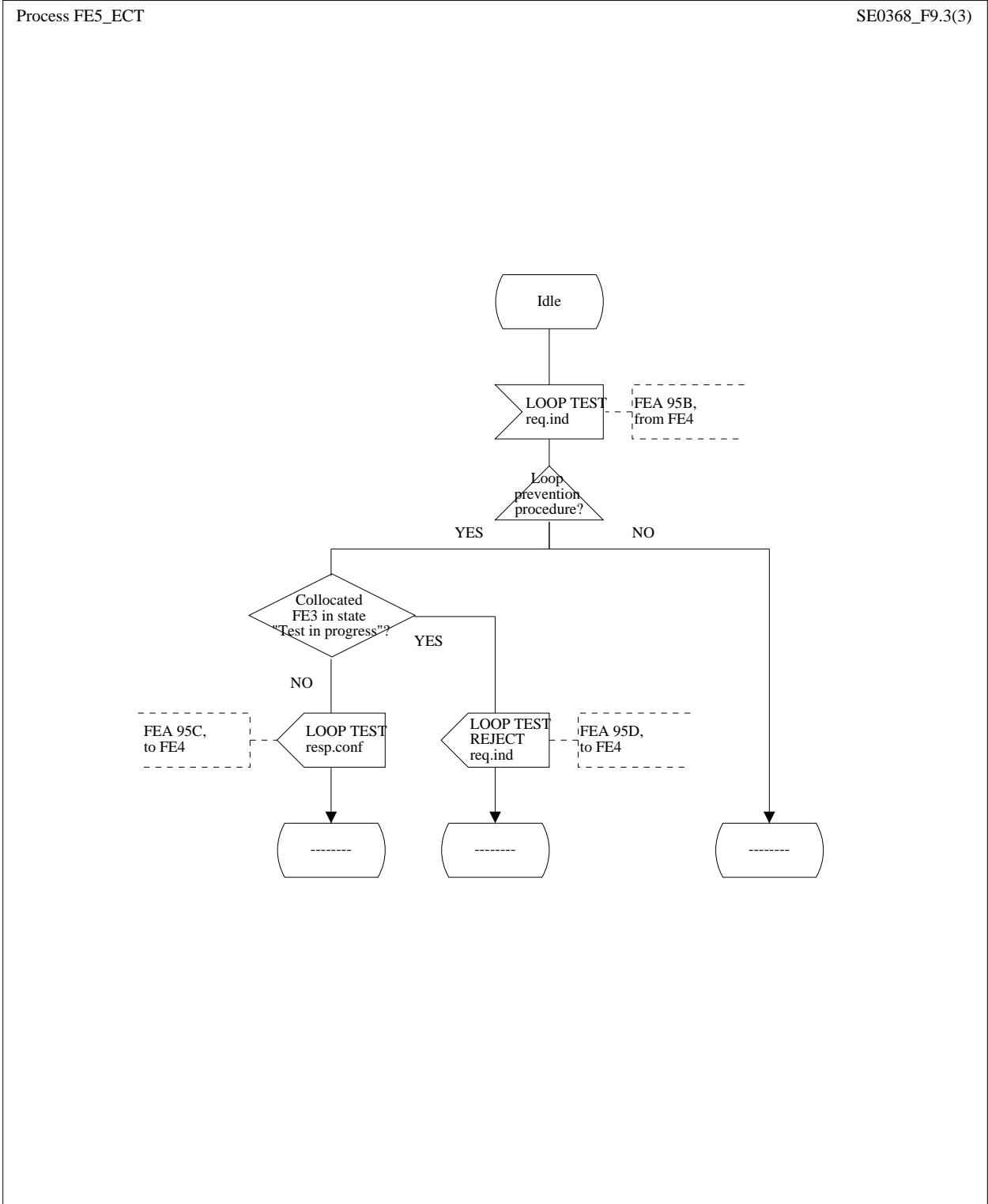

Figure 9 (sheet 3 of 3): SDL diagram for FE5

8.6 FE6

The SDL diagram for FE6 is shown in figure 10.

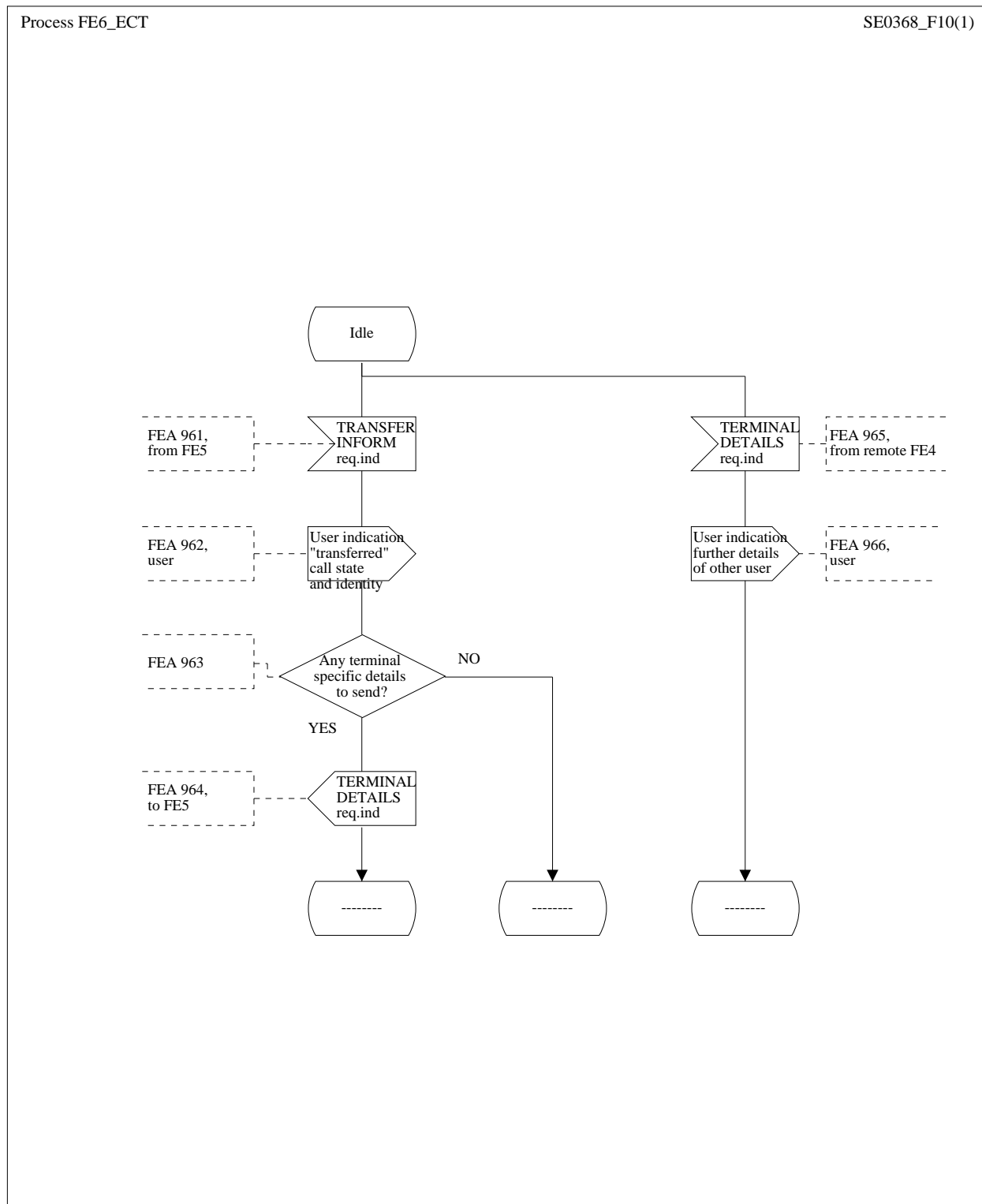

Figure 10: SDL diagram for FE6

9 Functional Entity Actions (FEAs)

9.1 FEAs of FE1

- 911: FE1 receives the request for transfer.
- 912: FE1 optionally performs local checks with respect to the compatibility of the two calls against information held with the CCAs.
- 913: If the request is found locally to be invalid, the requesting user is informed that the transfer has failed.
- 914: If the request is found locally to be valid, FE2 is requested to execute the transfer.
- 915: FE1 receives the result of the transfer from FE2.
- 916: FE1 examines the result of the transfer.
- 917: If the transfer is successful, the requesting user is informed of the successful completion. Optionally the calls involved may be released (if they have not already been cleared by FE2).
- 918: If the transfer is unsuccessful, the requesting user is informed.

9.2 FEAs of FE2

- 921: FE2 receives the request for invocation of transfer from FE1.
- 922: FE2 determines whether the transfer is valid in terms of the two calls to be transferred. Such checks are network specific; when FE2 resides in the public network it shall check that one call is answered and held and that the other call is not held and is answered or alerting (see table 1), that the requesting user is not a conference controller, that the three-party supplementary service has not been invoked by the requesting user, and that closed user group restrictions would not be violated if the transfer were allowed to proceed. Checks performed when FE2 is in another network are outside the scope of this ETS.
- 923: If the transfer is permitted, a request for transfer is sent to FE3.
- 924: If the transfer is barred, a response indicating rejection is returned to FE1.
- 925: The result of the transfer is received from FE3.
- 926: The result of the transfer is relayed to FE1.

9.3 FEAs of FE3

- 931: FE3 receives the request for invocation of transfer from FE2.
- 932: FE3 identifies the primary and secondary calls.
- 933: FE3 shall verify whether the requested transfer is allowed or e.g. should be registered for operational reasons, or would violate closed user group restrictions if allowed to proceed.
- 934: If the transfer is permitted, a response indicating success is returned to FE2.

- 935: If the transfer is barred, a response indicating rejection is returned to FE2.
- 936: The call paths from user A's exchange toward user B and user C are joined together.
- 937: The call paths from user A's exchange toward user A are cleared.
- 938: Completion of the transfer is indicated to user B's exchange. This includes the identity of user C where known and an indication of whether user C is being alerted.
- 939: Completion of the transfer is indicated to user C's exchange. This includes the identity of user B where known.
- 93A: Following an alerting transfer, answer by user C is indicated to user B's FE4 on receipt of the basic call setup confirmation by the Call Control (CC) collocated with FE3.
- 93B: As a network option, a LOOP TEST req.ind is sent to both FE4s to determine if a loop exists.
- 93C: As a network option, the results of the loop test are processed.

9.4 FEAs of FE4

- 941: FE4 receives the indication of transfer completion from FE3.
- 942: The indication of transfer completion is passed to the local FE5.
- 943: Any active user-to-user signalling supplementary service is cancelled.
- 944: Details received in the transfer complete indication relevant to the network are stored.
- 945: FE4 receives terminal specific details intended for the remote user from the local FE5.
- 946: FE4 determines whether or not such information transfer is allowed. The mechanism for deciding upon this (for example a timer or counter) is implementation dependent.
- 947: If the information can be transferred, it is sent to the remote FE6.
- 948: FE4 receives the indication that answer has taken place subsequent to an alerting transfer.
- 949: Details received in the transfer active indication relevant to the network are stored.
- 94A: The indication that answer has taken place is passed to the local FE5 applying any restriction requirements to identity information, if appropriate.
- 94B: As a network option, a LOOP TEST req.ind received from FE3 is relayed to FE5.
- 94C: As a network option, a LOOP TEST resp.conf received from FE5 is relayed to FE3.
- 94D: As a network option, a LOOP TEST REJECT req.ind received from FE5 is relayed to FE3.

9.5 FEAs of FE5

- 951: FE5 receives the indication of transfer completion from FE4.
- 952: The indication of transfer completion is passed to the local FE6.
- 953: Any outstanding notifications (for example that the local user is holding) are sent to the remote user.
- 954: Details received in the transfer complete indication relevant to the network are stored.
- 955: FE5 receives terminal specific details intended for the remote user from the local FE6.
- 956: FE4 determines whether or not such information transfer is allowed. The mechanism for deciding upon this (for example a timer or counter) is implementation dependent.
- 957: If the information can be transferred, it is relayed to the local FE4.
- 958: FE5 receives the indication that answer has taken place subsequent to an alerting transfer.
- 959: Details received in the transfer active indication relevant to the network are stored.
- 95A: The indication that answer has taken place is passed to the local FE6 applying any restriction requirements to identity information, if appropriate.
- 95B: As a network option, a LOOP TEST req.ind received from FE4 is processed.
- 95C: As a network option, if there is no collocated FE3 in state "TEST IN PROGRESS" for the same call, a LOOP TEST resp.conf is sent to FE4.
- 95D: As a network option, if there is no collocated FE3 in state "TEST IN PROGRESS" for the same call, a LOOP TEST REJECT req.ind is sent to FE4.
- 95E: Any active user-to-user signalling supplementary service is cancelled.

9.6 FEAs of FE6

- 961: FE6 receives the indication that a transfer or answer following an alerting transfer has taken place.
- 962: The local user is informed of the transfer or the answer and the other details associated with it, such as other party number (if received).
- 963: FE6 determines whether there is any subaddress to be sent to the other user.
- 964: If there is a subaddress to be sent, this is indicated to the local FE5.
- 965: FE6 receives the subaddress associated with the remote terminal.
- 966: The local user is informed of the other terminal's subaddress.

10 Allocation of FEs to physical locations

The possible physical locations of FEs are shown in table 12.

Table 12: Allocation of functional entities

	FE1	FE2	FE3	FE4	FE5	FE6
Scenario 1 (note)	A's TE	A's LE	A's LE	B's LE C's LE	B's LE C's LE	B's TE C's TE
Scenario 2 (note)	A's TE	A's LE	A's LE	B's LE C's LE	B's PTNX C's LE	B's TE C's TE
Scenario 3 (note)	A's TE	A's LE	A's LE	B's LE C's LE	B's LE C's PTNX	B's TE C's TE
Scenario 4 (note)	A's TE	A's LE	A's LE	B's LE C's LE	B's PTNX C's PTNX	B's TE C's TE
Scenario 5	A's TE	A's PTNX	PTNX	B's LE C's LE	B's LE C's LE	B's TE C's TE
Scenario 6	A's TE	A's PTNX	PTNX	B's LE C's LE	B's PTNX C's LE	B's TE C's TE
Scenario 7	A's TE	A's PTNX	PTNX	B's LE C's LE	B's LE C's PTNX	B's TE C's TE
Scenario 8	A's TE	A's PTNX	PTNX	B's LE C's LE	B's PTNX C's PTNX	B's TE C's TE
NOTE: FE4 can also be allocated in the gateway of user A's network.						

Scenario 1 represents transfer by join either entirely within one public network, or between different public networks.

Scenarios 2, 3 and 4 represent transfer by join where user B, user C, and both user B and user C are in a private network, respectively.

Scenarios 5, 6, 7 and 8 represent transfer (by join or rerouteing) where the transfer is invoked from and controlled within a private network for the cases where both user B and user C, only user C, only user B, and neither user B nor user C are in the public network, respectively. In these scenarios, the Private Telecommunication Network eXchange (PTNX) where the functionality of FE3 is realized may or may not be user A's PTNX and in the case of transfer by rerouteing the functionality may be split across a number of PTNXs.

Scenarios where FE2 and FE3 are not collocated, allowing a private network to invoke the service of the public network, are outside the scope of this ETS.

History

Document history	
March 1994	Public Enquiry PE 58: 1994-03-07 to 1994-07-01
March 1995	Vote V 75: 1995-03-06 to 1995-04-28
May 1995	First Edition
February 1996	Converted into Adobe Acrobat Portable Document Format (PDF)