



INTERIM
EUROPEAN
TELECOMMUNICATION
STANDARD

I-ETS 300 353

October 1998

Second Edition

Source: NA

Reference: RI/NA-052626

ICS: 33.020

Key words: B-ISDN, ATM, AAL

**Broadband Integrated Services Digital Network (B-ISDN);
Asynchronous Transfer Mode (ATM);
Adaptation Layer (AAL) specification - type 1**

ETSI

European Telecommunications Standards Institute

ETSI Secretariat

Postal address: F-06921 Sophia Antipolis CEDEX - FRANCE

Office address: 650 Route des Lucioles - Sophia Antipolis - Valbonne - FRANCE

Internet: secretariat@etsi.fr - <http://www.etsi.org>

Tel.: +33 4 92 94 42 00 - Fax: +33 4 93 65 47 16

Copyright Notification: No part may be reproduced except as authorized by written permission. The copyright and the foregoing restriction extend to reproduction in all media.

© European Telecommunications Standards Institute 1998. All rights reserved.

Annex A (informative):	Illustration of the data unit naming convention.....	32
Annex B (informative):	Encoding and information transfer principles.....	33
B.1	Cell payload field encoding.....	33
B.2	AAL user information transfer.....	33
Annex C (informative):	Functional model for the circuit transport with AAL type 1.....	35
C.1	Functional model of the SAR.....	35
C.2	SDL of the SAR.....	36
Annex D (informative):	Parameters for AAL type 1 protocol.....	38
D.1	Circuit transport.....	38
D.1.1	Transport of digital channel supported by 64 kbit/s-based ISDN.....	38
D.1.2	Transport of G.702 PDH circuit.....	38
D.1.3	Transport of G.707 SDH circuit.....	39
D.2	Video signal transport.....	39
D.3	Voiceband signal transport.....	40
Annex E (informative):	Algorithm to detect lost and misinserted cells in AAL 1.....	41
E.1	General.....	41
E.2	Indications from the SAR sublayer.....	41
E.3	Capabilities of the algorithms.....	41
E.4	The algorithms.....	41
E.4.1	Robust SN Algorithm.....	41
E.4.2	Fast SN Algorithm.....	43
Annex F (normative):	Protocol Implementation Conformance Statement (PICS) proforma for the AAL type 1.....	46
F.1	Introduction.....	46
F.2	PICS.....	46
F.2.1	SAR sublayer.....	46
F.2.1.1	Capabilities.....	46
F.2.1.2	PDUs and PDU parameters.....	47
F.2.2	CS major capabilities.....	47
F.2.2.1	CS for circuit transport.....	47
F.2.2.1.1	Capabilities.....	47
F.2.2.1.2	Protocol parameters.....	48
F.2.2.2	CS for video signal transport.....	49
F.2.2.2.1	Capabilities.....	49
F.2.2.2.2	Protocol parameters.....	49
F.2.2.3	CS for voice band signal transport.....	50
F.2.2.3.1	Capabilities.....	50
F.2.2.3.2	Protocol parameters.....	50
History.....		51

Foreword

This Interim European Telecommunication Standard (I-ETS) has been produced by the Network Aspects (NA) Technical Committee of the European Telecommunications Standards Institute (ETSI).

Announcement date	
Date of adoption of this I-ETS:	9 October 1998
Date of latest announcement of this I-ETS (doa):	3 months after ETSI publication

Introduction

The content of this I-ETS is derived from ITU-T Recommendation I.363.1 [8]. This I-ETS is one of a set of I-ETSs describing different Asynchronous Transfer Mode (ATM) Adaptation Layer (AAL) types.

The AAL uses the ATM layer service and offers its layer service to the higher layers. The connection-oriented transmission methods which provide timing relation between sending and receiving AAL service users, are described in ITU-T Recommendation I.363.1 [8], clause 2. These methods form the AAL type 1. They check the validity of the cell sequence count, transmit and utilize time stamp information for source clock recovery at the receiver as a user option, optionally correct data by using Forward Error Correction (FEC) and offer utilities to transfer structured data. Subtypes are defined for "circuit transport", "video signal transport" and "voice-band signal transport".

Blank page

1 Scope

As ITU-T Recommendation I.363.1 [8] contains options and describes methods which can be used in different combinations, this Interim European Telecommunication Standard (I-ETS) minimizes the options and methods and describes a subset of the Asynchronous Transfer Mode (ATM) Adaptation Layer (AAL) type 1 to be used in Europe.

This I-ETS describes the interactions between the AAL and the next higher layer, and the AAL and the ATM layer, as well as AAL peer-to-peer operations.

2 Normative references

This I-ETS incorporates by dated and undated reference, provisions from other publications. These normative references are cited at the appropriate places in the text and the publications are listed hereafter. For dated references, subsequent amendments to or revisions of any of these publications apply to this I-ETS only when incorporated in it by amendment or revision. For undated references the latest edition of the publication referred to applies.

- [1] ITU-T Recommendation G.702: "Digital hierarchy bit rates".
- [2] ITU-T Recommendation G.707: "Network node interface for the synchronous digital hierarchy (SDH)".
- [3] ITU-T Recommendation G.711: "Pulse code modulation (PCM) of voice frequencies".
- [4] ITU-T Recommendation G.823: "The control of jitter and wander within digital networks which are based on the 2048 kbit/s hierarchy".
- [5] ITU-T Recommendation G.824: "The control of jitter and wander within digital networks which are based on the 1544 kbit/s hierarchy".
- [6] ITU-T Recommendation I.231: "Circuit-mode bearer service categories".
- [7] ITU-T Recommendation I.361 (1993): "B-ISDN ATM layer specification".
- [8] ITU-T Recommendation I.363.1 (1996): "B-ISDN ATM Adaptation: Type 1 AAL".
- [9] ITU-T Recommendation J.82 (1995): "Transport of MPEG-2 constant bit rate television signals in B-ISDN".
- [10] ITU-T Recommendation H.310 (1995): "Broadband audiovisual communication systems and terminals".
- [11] ITU-T Recommendation H.320 (1993): "Narrow-band visual telephone systems and terminal equipment".
- [12] ITU-T Recommendation H.321: "Adaptation of H.320 visual telephone terminals to B-ISDN environments".
- [13] ITU-T Recommendation H.221 (1995): "Frame structure for a 64 to 1 920 kbit/s channel in audiovisual teleservices".

3 Definitions and abbreviations

3.1 Definitions

For the purposes of this I-ETS, the following definitions apply:

ATM Adaptation Layer (AAL): The AAL uses the ATM layer service and includes multiple protocols to fit the need of the different AAL service users. In AAL type 1 source timing recovery is provided at the receiver.

Convergence Sublayer Indication (CSI): The CSI is a part of the Protocol Control Information (PCI) in the SAR sublayer; it indicates a special event in the sending Convergence Sublayer (CS) entity in combination with the Sequence Count (SC) and depending on the AAL subtype used: it supports source clock timing recovery using the SRTS method, data structure indication using the SDT method and bit error and cell loss recovery using Forward Error Correction (FEC).

Forward Error Correction (FEC): The FEC method is adapted to the error conditions at the ATM layer.

non-P format: Format of the SAR-PDU (Protocol Data Unit) payload, which does not carry a pointer of the SDT method.

P format: Format of the SAR-PDU payload which carries a pointer of the SDT method.

Residual Time Stamp (RTS): The SRTS method uses the RTS value to measure and convey information about the frequency differences between a common reference clock (derived from the network) and a service clock. The same derived network clock is assumed to be available at both the transmitter and the receiver.

Sequence Count (SC): This 3-bit field counts the SAR-PDUs from 0 to 7 (modulo 8).

Sequence Number (SN): The SN field consists of the 1-bit indication called CSI and a 3-bit SC in the SAR-PDUs.

Sequence Number Protection (SNP): The SNP protects the SN by Cyclic Redundancy Check (CRC) and parity check.

Structured Data Transfer (SDT): The SDT method supports the transmission of structured data (blocks of user data organized in octets) by using a pointer to the start of a block.

Synchronous Residual Time Stamp (method) (SRTS): This method uses the RTS values (transferred peer-to-peer) to recover the source service clock at the receiver side.

3.2 Abbreviations

For the purposes of this I-ETS, the following abbreviations apply:

AAL	ATM Adaptation Layer
ATM	Asynchronous Transfer Mode
CRC	Cyclic Redundancy Check
CS	Convergence Sublayer
CSI	Convergence Sublayer Indication
FEC	Forward Error Correction
PCI	Protocol Control Information
PDU	Protocol Data Unit
PICS	Protocol Implementation Conformance Statement
RPOA	Recognized Private Operating Agency
RTS	Residual Time Stamp
SAP	Service Access Point
SAR	Segmentation And Reassembly (sublayer)
SC	Sequence Count
SDH	Synchronous Digital Hierarchy
SDL	Specification and Description Language
SDT	Structured Data Transfer
SDU	Service Data Unit
SN	Sequence Number
SNP	Sequence Number Protection
SRTS	Synchronous Residual Time Stamp (method)
STM-1	Synchronous Transport Module - 1

4 AAL type 1

The AAL enhances the service provided by the ATM layer to support functions required by the next higher layer. The AAL performs functions required by the user, control and management planes and supports the mapping between the ATM layer and the next higher layer. The functions performed in the AAL depend upon the higher layer requirements.

The AAL supports multiple protocols to fit the needs of the different AAL service users. The service provided by the AAL type 1 protocol to the higher layer and the functions performed are specified in this I-ETS.

Details of the data unit naming convention used in this I-ETS can be found in annex A.

This I-ETS describes the interactions between the AAL and the next higher layer, and the AAL and the ATM layer, as well as AAL peer-to-peer operations.

Different combinations of SAR sublayers and CS provide different Service Access Points (SAPs) to the layer above the AAL.

4.1 Service primitives provided by AAL type 1

The layer service capabilities provided by AAL type 1 to the AAL user are:

- transfer of service data units with a constant source bit rate and the delivery of them with the same bit rate;
- transfer of timing information between source and destination;
- transfer of structure information between source and destination;
- indication of lost or errored information which is not recovered by AAL type 1, if needed.

At the AAL-SAP, the following primitives are used between the AAL type 1 and the AAL user. They represent an abstract model of the interface and they are not intended to constrain implementations:

- from an AAL user to the AAL,
AAL-UNITDATA-REQUEST;
- from the AAL to an AAL user,
AAL-UNITDATA-INDICATION.

An AAL-UNITDATA-REQUEST primitive at the local AAL-SAP results in an AAL-UNITDATA-INDICATION primitive at its peer AAL-SAP.

4.1.1 AAL-UNITDATA-REQUEST

AAL-UNITDATA-REQUEST:

- (DATA [mandatory];
- STRUCTURE [optional]).

The AAL-UNITDATA-REQUEST primitive requests the transfer of the AAL-SDU, i.e. contents of the DATA parameter, from the local AAL entity to its peer entity. The length of the AAL-SDU is constant and the time interval between two consecutive primitives is constant. These two constants depend upon the specific AAL service provided to the AAL user.

4.1.2 AAL-UNITDATA-INDICATION

AAL-UNITDATA-INDICATION:

- (DATA [mandatory];
- STRUCTURE [optional];

- STATUS [optional]).

An AAL user is notified by the AAL that the AAL-SDU from its peer is available (i.e. via the contents of the DATA parameter). The length of the AAL-SDU shall be constant and the time interval between two consecutive primitives shall be constant. These two constants depend upon the specific AAL service provided to the AAL user.

4.1.3 Definition of parameters

4.1.3.1 DATA parameter

(Mandatory).

The DATA parameter carries the AAL-SDU to be sent or delivered. Its size depends on the specific AAL service used.

4.1.3.2 STRUCTURE parameter

(Optional use).

The STRUCTURE parameter can be used when the user data stream to be transferred to the peer AAL entity is organized into groups of octets. The length of the structured block is fixed for each instance of the AAL service. The length is an integer multiple of one octet. An example of the use of this parameter is to support circuit mode bearer services of the 64 kbit/s based ISDN. If the optional parameter is present, the two values of the STRUCTURE parameter are:

- START; and
- CONTINUATION.

The value START is used when the DATA is the first part of a structured block which can be composed of consecutive DATA. In other cases, the STRUCTURE parameter is set to CONTINUATION. The use of the STRUCTURE parameter depends upon the specific AAL service provided. The use of this parameter is agreed prior to or at the connection establishment between the AAL user and the AAL.

4.1.3.3 STATUS parameter

(Local optional use).

The STATUS parameter identifies that the DATA is judged to be non-errored or errored. The STATUS parameter has two values:

- VALID; and
- INVALID.

The INVALID status can also indicate that the DATA is a dummy value. The use of the STATUS parameter and the choice of dummy value depend upon the specific AAL service provided. The use of this parameter is agreed prior to or at the connection establishment between the AAL user and the AAL.

4.2 Information flow across the ATM-AAL boundary

ITU-T Recommendation I.361 [7] describes the primitives exchanged between the ATM layer and the AAL. This subclause describes the usage of these primitives for AAL type 1.

The AAL receives from the ATM layer the information in the form of a 48 octet ATM Service Data Unit (ATM-SDU). The AAL passes to the ATM layer information in the form of a 48 octet ATM SDU.

The submitted CLP (Cell Loss Priority) in the request primitive is set to the high priority by the AAL transmitter. The value of the receive loss priority in the indication primitive is ignored by the AAL receiver.

The AUU (ATM-user-to-ATM-user) parameter is set to "0" in the request primitive. Future procedures may require that the AUU parameter can be set to "0" or "1". Such usage is reserved for future standardization.

The congestion indication is ignored by the AAL receiver.

The encoding principles for mapping information between the ATM layer and AAL type 1 are given in annex B.

4.3 Primitives between the SAR sublayer and the CS

4.3.1 General

These primitives model the exchange of information between the SAR sublayer and the Convergence Sublayer (CS). As there exists no Service Access Point (SAP) between the sublayers of the AAL type 1, the primitives are called "invoke" and "signal" instead of the conventional "request" and "indication" to highlight the absence of the SAP. Functional model and SDL is given in annex C.

4.3.1.1 SAR-UNITDATA-INVOKE

SAR-UNITDATA-INVOKE at the AAL type 1 transmitter has the following parameters:

- Interface data: This parameter specifies the interface data unit passed from the CS to the SAR entity. The interface data is 47 octets, and represents a SAR-PDU payload;
- CSI: The Convergence Sublayer Indication (CSI), either "0" or "1", is passed from the CS to the SAR entity;
- Sequence count: The sequence count value is passed from the CS to the SAR entity. The value of sequence count starts with 0, is incremented sequentially and is numbered modulo 8.

4.3.1.2 SAR-UNITDATA-SIGNAL

SAR-UNITDATA-SIGNAL at the AAL type 1 receiver has the following parameters:

- Interface data: This parameter specifies the interface data unit passed from the SAR to the CS entity. The interface data is 47 octets, and represents a SAR-PDU payload;
- CSI: The CSI is passed from the SAR to CS entity, regardless of the check status (valid or invalid);
- Sequence count: The sequence count value is passed from the SAR to CS entity, regardless of the check status (valid or invalid);
- Check status: This parameter specifies the status of the sequence count and CSI, and has the value of either valid or invalid.

4.4 Interaction with the management and control planes

Currently no interactions are standardized.

4.4.1 Management plane

For example, the following indications may be passed from the user plane to the management plane:

- errors in the transmission of user information;
- lost and misinserted cells;
- cells with errored AAL-PCI;
- loss of timing and synchronization;
- buffer underflow and overflow.

4.4.2 Control plane

Currently no interactions are standardized.

4.5 Functions of AAL type 1

The following functions may be performed in the AAL type 1 in order to enhance the ATM layer service:

- a) segmentation and reassembly of user information;
- b) blocking and deblocking of user information;
- c) handling of cell delay variation;
- d) handling of cell payload assembly delay;
- e) handling of lost and misinserted cells;
- f) source clock frequency recovery at the receiver;
- g) recovery of the source data structure at the receiver;
- h) monitoring of AAL-PCI for bit errors;
- i) handling of AAL-PCI bit errors;
- j) monitoring of user information field for bit errors and possible corrective action.

NOTE: For some AAL users, the end-to-end QoS may be monitored. This may be achieved by calculating a CRC for the CS-PDU payload, carried in one or more cells, and transmitting the CRC results in the CS-PDU or by the use of OAM cells.

4.6 SAR sublayer

4.6.1 Functions of the SAR sublayer

The SAR sublayer functions are performed on an ATM-SDU basis:

- a) mapping between CS-PDU and SAR-PDU:
 - the SAR sublayer at the transmitting end accepts a 47 octet block of interface data from the CS, and then prepends a one octet SAR-PDU header to each block to form the SAR-PDU;
 - the SAR sublayer at the receiving end receives the 48 octet block of data from the ATM layer, and then separates the SAR-PDU header. The 47 octet block of SAR-PDU payload (interface data) is passed to the CS;
- b) indication of existence of CS function:
 - the SAR sublayer has the capability to indicate the existence of a CS function. Associated with each 47 octet SAR-PDU payload, it receives this indication (CSI) from the CS and conveys it to the peer CS entity;
- c) sequence numbering:
 - associated with each SAR-PDU payload, the SAR sublayer receives a sequence count value from the CS. At the receiving end, it passes the SC value to the CS. The CS may use these SC values to detect lost or misinserted SAR-PDU payloads (corresponding to lost or misinserted ATM cells);
- d) error protection:

- the SAR sublayer protects the SC value and the CS indication against bit errors. It informs the receiving CS by the value of check status whether the SC value and/or the CS indication are errored.

4.6.2 SAR protocol

The SAR-PDU header together with the 47 octets of the SAR-PDU payload comprises the 48 octet ATM-SDU (cell information field). The size and positions of the fields in the SAR-PDU are given in figure 1.

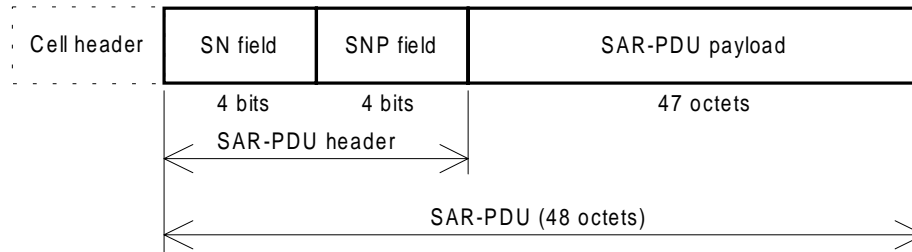

Figure 1: SAR-PDU format of AAL type 1

4.6.2.1 SN field

The SN field is divided into two subfields as shown in figure 2. The SC field carries the SC value provided by the CS. The CSI bit carries the CS indication provided by the CS. The default value of the CSI bit is "0".

The least significant bit of the SC value is right justified in the SC field.

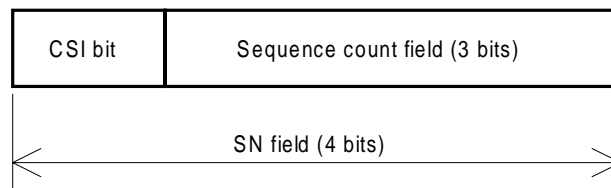

Figure 2: SN field format

4.6.2.2 SNP field

The SNP field provides error detection and correction capabilities over the SAR-PDU header. The format of this field is given in figure 3. A two step approach is used for the protection:

- 1) the SN field is protected by a 3 bit CRC code;
- 2) the resulting 7 bit code word is protected by an even parity bit, i.e. the parity bit is set such that the 8 bit SAR-PDU header has an even parity.

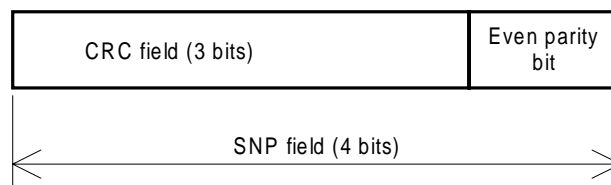

Figure 3: SNP field format

The receiver is capable of either single-bit error correction or multiple-bit error detection:

- a) operations at transmitting end:
 - the transmitter computes the CRC value across the first 4 bits of the SAR-PDU header and inserts the result in the CRC field.

The notation used to describe the CRC is based on the property of cyclic codes. The elements of an n-element code word are thus the coefficients of a polynomial of order n-1. In this application, these coefficients can have the value 0 or 1 and the polynomial operations are performed using modulo 2 operations. For example a code vector such as 1011 can be represented by the polynomial $P(x) = x^3 + x + 1$. The polynomial representing the content of the SN field is generated using the left most bit of the SN field as the coefficient of the highest order term.

The CRC field consists of three bits. It shall contain the remainder of the division (modulo 2) by the generator polynomial $x^3 + x + 1$ of the product x^3 multiplied by the content of the SN field. The coefficient of the x^2 term in the remainder polynomial is left justified in the CRC field;

- after completing the above operations, the transmitter inserts the even parity bit (i.e. the sum of the eight bits shall be even);

b) operations at receiving end:

The receiver has two different modes of operation: correction mode and detection mode. These modes are related as shown in figure 4. The default mode is the correction mode, which provides for single-bit error correction. At initialization, the receiver is set up in this default mode;

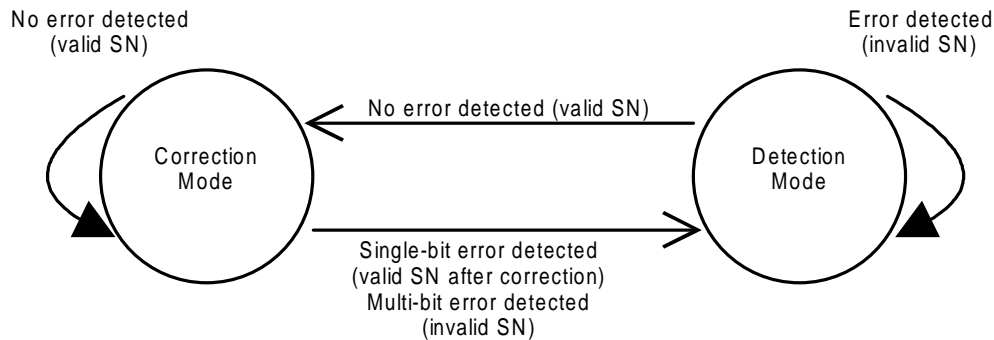

Figure 4: SNP - receiver modes of operation

- the receiver examines each SAR-PDU header by checking the CRC and the even parity. If a header error is detected, the action taken depends on the state of the receiver. In the "Correction Mode", only single-bit errors can be corrected and the receiver switches to "Detection Mode". In "Detection Mode", all SAR-PDU headers with detected errors are declared to have an invalid SN; however, when a SAR-PDU header is examined and found not to be in error, the receiver switches to "Correction Mode";
- tables 1 and 2 give the detailed mandatory operations of the receiver in the "Correction Mode" and "Detection Mode", respectively. The operation is based on the combined validity of the CRC and the parity bit.

The receiver shall convey the sequence count and the CS indication to the CS together with SN check status (valid or invalid).

Table 1: Operations in Correction Mode

CRC syndrome	Parity	Action on current SN + SNP	Reaction for next SN + SNP
Zero	No violation	No corrective action. Declare SN valid.	Continue in Correction Mode
Non-zero	Violation	Single bit correction based on syndrome. Declare SN valid.	Switch to Detection Mode
Zero	Violation	Correct Parity bit. Declare SN valid.	Switch to Detection Mode
Non-zero	No violation	No corrective action: multi-bit errors are uncorrectable. Declare SN invalid.	Switch to Detection Mode

Table 2: Operations in Detection Mode

CRC syndrome	Parity	Action on current SN + SNP	Reaction for next SN + SNP
Zero	No violation	No corrective action. Declare SN valid.	Switch to Correction Mode
Non-zero	Violation	No corrective action. Declare SN invalid.	Continue in Detection Mode
Zero	Violation	No corrective action. Declare SN invalid.	Continue in Detection Mode
Non-zero	No violation	No corrective action. Declare SN invalid.	Continue in Detection Mode

4.7 Convergence Sublayer (CS)

4.7.1 Functions of the CS

Depending on the specific AAL service provided, the CS may include the following functions:

- a) blocking of user information to form a 47 octet block of SAR-PDU payload is performed at this sublayer. If no octet interleaving is applied, the AAL-SDUs are sequentially concatenated. They are placed left justified in the 47 octet block beginning from the first octet available for user information. The deblocking function is the reverse of the blocking function. It segments the user information into a stream of AAL-SDUs again;
- b) handling of cell delay variation for delivery of AAL-SDUs to an AAL user at a constant bit rate;
- c) handling of SAR-PDU payload assembly delay may be performed by partially filling the SAR-PDU payload;
- d) processing of SC. The SC value and its error check status provided by the SAR sublayer can be used by the CS to detect cell loss and misinsertion. Further handling of lost and misinserted cells is also performed in this sublayer;
- e) the CS can utilize the CS indication provided by the SAR sublayer to support CS functions for some AAL users. When the CS indication is not used, the CSI bit is set to "0" by the transmitter, and no further CS action related to that indication is performed at the receiver, i.e., the CS receiver ignores the received CSI value;
- f) for AAL users requiring recovery of source clock frequency at the destination end, the AAL can provide a mechanism for a timing information transfer;
- g) transfer of structure information between source and destination;
- h) for video signal transport, FEC may be performed to protect against bit errors. This may be combined with interleaving of AAL user bits (e.g. octet interleaving) to correct cell losses;

- i) The CS may generate reports giving the status of end-to-end performance as deduced by the AAL. The performance measures in these reports could be based on:
- events of lost and misinserted cells;
 - buffer underflow and overflow;
 - bit error events.

AAL type 1 protocol aims at having as many common procedures as possible among various types of CBR services in an ATM network. As such, AAL type 1 CS protocol is somewhat of a tool kit, whereby a specific higher layer needs to choose procedures given in this I-ETS, taking account of required service features (e.g., synchronous or asynchronous transport), required performance (e.g., error and delay characteristics at the AAL service boundary), and anticipated network performance (e.g. cell losses and delay variations).

The following subclauses describe CS functions needed for three layer services, i.e., circuit transport, video signal transport and voiceband signal transport. These subclauses also refer to a specific procedure which is defined in subclause 4.7.2, where the description of each procedure is independent from CS functions. These four layer services and associated description of required procedures are general and not exhaustive. Annex D gives informative and example parameters, i.e., a set of procedures and options, for some specific AAL type 1 services. Having this structural description, this I-ETS gives the ground for a generic protocol to support a large number of CBR services.

4.7.1.1 Functions of the CS for circuit transport

The following functions support both asynchronous and synchronous circuit transport.

Asynchronous circuit transport provides transport of signals from constant bit rate sources whose clocks are not frequency-locked to a network clock. Examples are ITU-T Recommendation G.702 [1] signals at 1 544 kbit/s, 2 048 kbit/s, 6 312 kbit/s, 8 448 kbit/s, 32 064 kbit/s, 34 368 kbit/s and 44 736 kbit/s.

Synchronous circuit transport provides transport of signals from constant bit rate sources whose clocks are frequency-locked to a network clock. Examples are signals at 64 kbit/s, 384 kbit/s, 1 536 kbit/s and 1 920 kbit/s as described in ITU-T Recommendation I.231 [6] or conveyance of Synchronous Digital Hierarchy (SDH) signals described in ITU-T Recommendation G.707 [2].

- a) handling of AAL user information:
- the default value for the length of the AAL-SDU is one bit;
 - for those AAL users which require transfer of structured data, e.g. 8 kHz structured data for circuit mode bearer services of the 64 kbit/s based ISDN, the STRUCTURE parameter option of the primitives defined in subclause 4.1.3.2 and the SDT method described in subclause 4.7.2.3 shall be provided and used. When the STRUCTURE parameter option is used without the SRTS method the length of the AAL-SDU is one octet. The SRTS method is described in subclause 4.7.2.2.2;
- b) handling of cell delay variation:
- a buffer is used to support this function. The size of this buffer is dependent upon ATM performance specifications (note). In the event of buffer underflow, the CS maintains bit count integrity by inserting the appropriate number of dummy bits and dropping the corresponding number of bits which follow this insertion. The inserted dummy bits are all "1"s; In the event of buffer overflow, the CS drops the appropriate number of bits;

NOTE: The ATM performance specifications are out of the scope of this I-ETS.

- c) handling of lost and misinserted cells:
- the SC values are further processed at this sublayer to detect lost and misinserted cells. The performance specifications for the processing of SC values are not yet defined. Detected misinserted cells are discarded. An informative example of processing is given in annex E;

- in order to maintain the bit count integrity of the AAL user information, lost cells detected by buffer underflow and SC processing are compensated by inserting the appropriate number of dummy SAR-PDU payloads; the content of this dummy SAR-PDU payload is all "1"s;
- d) handling of timing relation:
- this function is required for delivery of AAL-SDUs to an AAL user at a constant bit rate;
 - recovered source clock shall have satisfactory jitter and wander performance. The jitter and wander performance for ITU-T Recommendation G.702 [1] signals is specified in ITU-T Recommendations G.823 [4] and G.824 [5] for which the CS procedure to be used (the SRTS method) is described in subclause 4.7.2.2.2. For signals other than ITU-T Recommendation G.702 [1] signals possible timing recovery methods currently identified are: SRTS, adaptive clock method and a combination of SRTS and adaptive clock method.

4.7.1.2 Functions of the CS for video signal transport

The following functions support transport of video signals for interactive and distributive services:

- a) handling of AAL user information:
- the length of the AAL-SDU is one octet when utilizing the correction methods described in subclause 4.7.2.4;
 - for those AAL users which require transfer of structured data, the STRUCTURE parameter option of primitives defined in subclause 4.1.3.2 and the SDT method described in subclause 4.7.2.3 shall be provided and used. When the STRUCTURE parameter option is used without the SRTS method the length of the AAL-SDU is one octet;
 - depending on the type of AAL service provided (i.e. the interface to the AAL user) the STATUS parameter defined in subclause 4.1.3.3 is passed to the AAL user to facilitate further picture processing, e.g. error concealment or not;
- b) handling of cell delay variation:
- a buffer is used to support this function. The size of this buffer is dependent upon ATM performance specifications (note). In the event of buffer underflow, the CS maintains bit count integrity by inserting the appropriate number of dummy bits and dropping the corresponding number of bits which follow the insertion. The inserted dummy bits are all "1". In the event of buffer overflow, the CS drops the appropriate number of bits;

NOTE: The ATM performance specifications are out of the scope of this I-ETS.

- c) handling of lost and misinserted cells:
- the SC values are further processed at this sublayer to detect lost and misinserted cells. The performance specifications for the processing of SC values are not yet defined. Detected misinserted cells are discarded. An informative example of processing is given in annex E;
 - information in lost cells may be recovered by the mechanism described in e);
 - in order to maintain the bit count integrity of the AAL user information, lost cells detected by buffer underflow and SC processing are compensated by inserting the appropriate number of dummy SAR-PDU payloads. The content of this dummy SAR-PDU payload is all "1"s;
- d) handling of timing relation:
- this function is required for delivery of AAL-SDUs to an AAL user at a constant bit rate;
 - some AAL users may require source clock frequency recovery, e.g. recovery at the receiving end of camera clock frequency which is not locked to the network clock. Possible timing

recovery methods currently identified are: SRTS, adaptive clock method; the CS procedures available for that purpose are given in subclause 4.7.2.2;

e) correction of bit errors and lost cells:

- this is an optional function provided for those AAL users requiring error correction, i.e., bit error and/or cell loss performance better than that provided by the ATM and physical layer. Examples are unidirectional video services for contribution and distribution. When this function is performed, the CS procedure described in subclause 4.7.2.4 shall be applied.

4.7.1.3 Functions of the CS for voice-band signal transport

The following functions support transport of a single voice-band signal, i.e. one. 64 kbit/s A-law or μ -law coded ITU-T Recommendation G.711 [3] signal:

a) handling of AAL user information:

- the length of the AAL-SDU is one octet; forty seven consecutive AAL-SDUs constitute one SAR PDU payload, i.e., partially filled cells are not used. The CS provides structured data transfer with single octet delineation, i.e., the pointer is not used;

b) handling of cell delay variation:

- a buffer is used to support this function. The size of this buffer is dependent upon ATM performance specifications (note). In the event of buffer underflow, the CS maintains bit count integrity by inserting the appropriate number of dummy bits and dropping the corresponding number of bits which follow this insertion. The inserted dummy bits are all "1". In the event of buffer overflow, the CS drops the appropriate number of bits;

NOTE: The ATM performance specifications are out of the scope of this I-ETS.

c) handling of lost and misinserted cells:

- for voiceband signals, there is no need to detect misinserted cells;
- the receiving AAL entity shall detect/compensate for lost cell events to maintain bit count integrity, and shall also minimize the delay, i.e., to alleviate echo performance problems, in conveying the individual voiceband signal octets from the SAR-PDU payload to the AAL user. The receiving AAL entity may take actions based on the received SN values, but such actions shall not increase the conveyance delay across the AAL receiving entity beyond the nominal CDV value to alleviate echo performance problems. A possible SN processing algorithm that does not introduce additional delay is given in annex E.
- the AAL receiving entity shall accommodate a sudden increase or decrease in the nominal cell transfer delay (such a change in cell transfer delay can be the result of a protection switching event in the network);

d) handling of timing relation:

- the CS provides synchronous circuit transport for the voiceband signal;
- example receiver techniques use a timing based mechanism or buffer-fill based mechanism, possibly supplemented by an SN processing algorithm as given in annex E;

For transporting signals of speech and 3,1 kHz audio bearer services as specified in 64 kbit/s ISDN, the need for A-law to μ -law conversion is identified. The conversion between A-law and μ -law coded PCM octets is as specified in ITU-T Recommendation G.711 [3]. This conversion function is outside the scope of this I-ETS.

4.7.2 CS protocol

The following subclauses describe CS procedures to be provided for implementing CS functions. The use of each procedure depends on the required CS functions and is given in subclauses 4.7.1.1 to 4.7.1.3.

4.7.2.1 SC operations

4.7.2.1.1 SC operations at the transmitting end

At the transmitting end, the CS shall provide the SAR with a SC value and a CS indication associated with each SAR-PDU payload. The count value shall start with 0, be incremented sequentially and be numbered modulo 8.

4.7.2.1.2 SC operations at the receiving end

At the receiving end, the CS receives from the SAR the following information associated with each SAR-PDU payload if required:

- SC;
- Convergence Sublayer Indication (CSI);
- check status of the SN.

The use of SC values and CS indications will be specified on a service specific basis. See subclause 4.6.2 for details about the calculation of the check status.

The CS processing at the receiving end shall identify lost and misinserted SAR-PDU payloads if required.

CS processing shall identify the following conditions:

- SAR-PDU payload sequence normal (i.e. in correct sequence);
- SAR-PDU payload loss;
- SAR-PDU payload misinsertion.

Processing of SC values may provide information to CS layer management entities, as required. Some examples are:

- location of lost SAR-PDU payload in the incoming SAR-PDU stream;
- number of consecutive SAR-PDU payloads lost;
- identification of misinserted SAR-PDU payloads.

Informative examples of algorithms for the processing of sequence count values are given in annex E. Independent of which type of algorithm is used additional mechanisms have to be realized to preserve bit count integrity. This can, for example, be achieved by defining a time window (whose width is related to the nominal CDV) around the expected arrival instant of the next cell or by interpreting the buffer fill level and inserting or discarding the appropriate number of bits.

NOTE: Processing of SC values may be subject to performance specifications. The performance specifications will be applied on an AAL service specific basis.

4.7.2.2 Source clock frequency recovery method

For synchronous CBR services, the clock is locked to a clock available from the network.

The CS provides two methods for the support of asynchronous CBR services with clocks not locked to a network clock:

- adaptive clock method for those services which need to comply with jitter requirements but which do not need to comply with wander requirements, e.g. ITU-T Recommendation G.823 [4];
- Synchronous Residual Time Stamp (SRTS) method for those services which need to comply with jitter and wander requirements, e.g. ITU-T Recommendation G.823 [4].

If a circuit transport equipment is connected to the public network, the requirements of jitter and wander depend on services. For services which need to meet jitter and wander specifications in ITU-T recommendation G.823 [4], the use of SRTS method is recommended. In private networks with no stringent wander requirement, the adaptive clock method may be used.

4.7.2.2.1 Adaptive clock method

The adaptive clock method is a general method for source clock frequency recovery. No explicit timing information of the source clock is transported by the network, the method is based on the fact that the amount of transmitted data is an indication of the source frequency, and this information can be used at the receiver to recover the source clock frequency. By averaging the amount of received data over a period of time, CDV (Cell Delay Variation) effects are counteracted. The period of time used for averaging depends on the CDV characteristics.

The adaptive clock method is implemented at the receiving AAL. The implementation of the method is not standardized. One possible method to measure the amount of data is to use the fill level of the AAL user data buffer. The following is the general description of this method and does not preclude other adaptive clock methods.

The receiver writes the received data into a buffer, and then reads it out using a locally generated clock. Therefore the fill of the buffer depends on the source frequency and it is used to control the frequency of the local clock. Operations are the following: the fill level of the buffer is continuously measured and the measure is used to drive the phase-locked loop generating the local clock. The method maintains the fill level of the buffer around its medium position. To avoid buffer underflow or overflow, the fill level is maintained between two limits. When the level in the buffer goes to the lower limit, this means the frequency of the local clock is too high compared to the one of the source and so it has to be decreased; when the level in the buffer goes to upper limit, the frequency of the local clock is too low compared to the one of the source, and so it has to be increased.

4.7.2.2.2 SRTS method

4.7.2.2.2.1 General

The SRTS method uses the RTS to measure and convey information about the frequency difference between a common reference clock derived from the network and a service clock. The same derived network clock is assumed to be available at both the transmitter and the receiver. If the common network reference clock is unavailable (e.g. when working between different networks which are not synchronized), then the asynchronous clock recovery method is in a mode of operation associated with "Plesiochronous network operation" which is described in subclause 4.7.2.2.2.5. The SRTS method is capable of meeting the jitter specifications of the 2 048 Mbit/s hierarchy in ITU-T Recommendation G.823 [4] and the 1 544 Mbit/s hierarchy in ITU-T Recommendation G.824 [5].

The following is a description of the SRTS method. The description uses the notation below:

- | | |
|----|---|
| fs | service clock frequency; |
| fn | network clock frequency, e.g. 155,52 MHz; |

- f_{nx} derived reference frequency, $f_{nx} = f_n/x$, where x is a rational number defined by an inequality (see formula {1}, subclause 4.7.2.2.1.2);
- N period of RTS in cycles of the service clock of frequency f_s ;
- T period of the RTS in seconds;
- M (M_{nom} , M_{max} , M_{min}) number of f_{nx} cycles within a (nominal, maximum, minimum) RTS period;
- M_q largest integer smaller than or equal to M .

The SRTS concept is illustrated in figure 5. In a fixed duration T measured by N service clock cycles, the number of derived network clock cycles M_q is obtained at the transmitter. If M_q is transmitted to the receiver, the service clock of the source can be reconstructed by the receiver, since it has the necessary information: f_{nx} , M_q and N . However, M_q is actually made up of a nominal part and a residual part. The nominal part M_{nom} corresponds to the nominal number of f_{nx} cycles in T seconds and is fixed for the service. The residual part conveys the frequency difference information as well as the effect of the quantization and, therefore, can vary. Since the nominal part is a constant, it can be assumed that the nominal part of M_q is available at the receiver. Only the residual part of M_q is transmitted to the receiver.

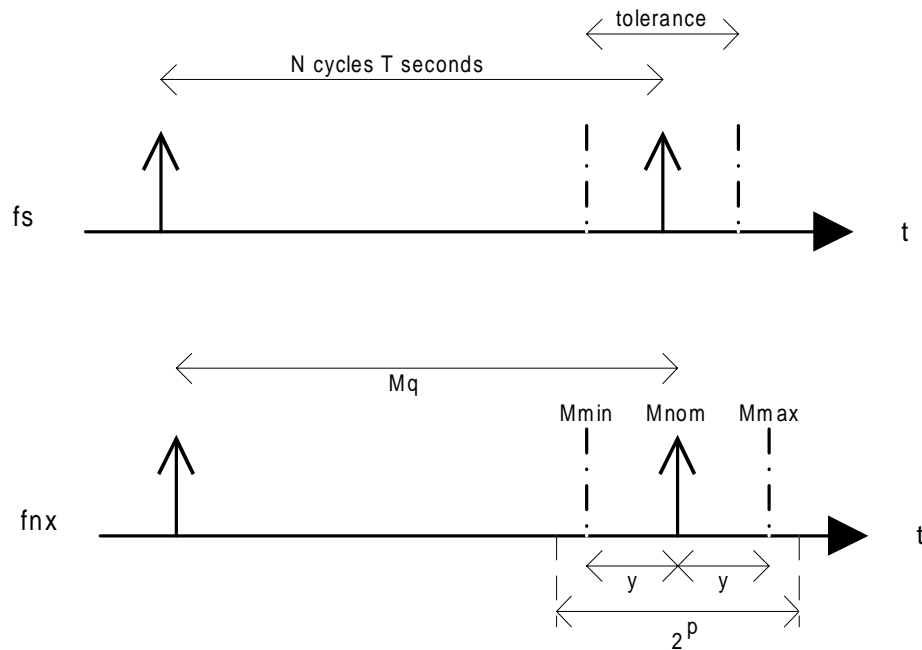

Figure 5: The concept of SRTS

A simple way of representing the residual part of M_q is by means of the RTS, whose generation is shown in figure 6. Counter C_t is a p -bit counter which is continuously clocked by the derived network clock. The output of counter C_t is sampled every N service clock cycles. This p -bit sample is the RTS.

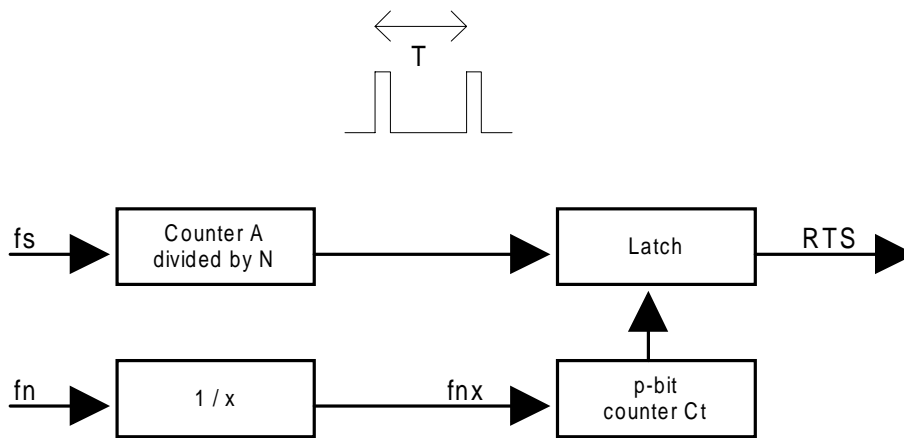

Figure 6: Generation of RTS

With a knowledge of the RTS and the nominal part of M_q at the receiver, M_q is completely specified. M_q is used to produce a reference timing signal for a Phase-Locked Loop to obtain the service clock.

At the sending side the p-bit counter C_t is set to zero when the first AAL-SDU is received via the primitive AAL-UNITDATA-REQUEST.

4.7.2.2.2 Choice of parameter

The minimum size of the RTS required to unambiguously represent the residual part of M_q is a function of N , the ratio fnx/fs , and the service clock tolerance, $\pm\epsilon$. Let y be the difference between M_{nom} and the maximum or minimum value of M (denoted as M_{max} , M_{min}). The difference y is given by:

$$y = N \times fnx/fs \times \epsilon$$

In order that M_q can be unambiguously identified, the following conditions shall be satisfied (see figure 5):

$$2^{(p-1)} > [y],$$

where $[y]$ denotes the smallest integer larger than or equal to y .

The following parameter values are used for the asynchronous circuit transport of ITU-T Recommendation G.702 [1] signals:

- $N = 3\ 008$ (total number of bits in eight SAR-PDU payloads);
- $1 \leq fnx/fs < 2$, {formula 1}
- Tolerance = 200×10^{-6}
- Size of RTS = 4 bits

The introduction of any AAL CS overhead into the SAR-PDU payload reduces the amount of payload available for the transport of AAL user data. This will reduce the number of service clock cycles over which the RTS period is specified, since the RTS period is defined over a fixed number of SAR-PDU payloads. The RTS period parameter, N , can be adjusted to accommodate such cases. The CS overhead has to be allocated so that the RTS period always remains a constant number of service clock cycles. Therefore, the CS overhead will reduce the user data transport capacity by a constant amount over the fixed number of SAR-PDU payloads for which the RTS period is defined. As an example, the P format in the SDT method is used exactly once per cycle, where a cycle is the sequence of eight consecutive SAR-PDUs with the sequence count values 0 through 7, N is reduced from 3 008 to 3 000.

4.7.2.2.3 Derived reference clocks

For SDH and non-SDH physical layers, a clock at frequency $f_8 = 8$ kHz, synchronized to a common network clock, is available from which clocks at frequencies

$$f_{nx} = f_8 \times 19\,440 \times 2^{-k} \text{ kHz, } k = 0, 1, \dots, 11$$

can be derived. This set of derived frequencies can accommodate all service rates from 64 kbit/s up to the full capacity of the STM-1. The exact value of f_{nx} to be used is uniquely specified since the frequency ratio is constrained by $1 \leq f_{nx}/f_8 < 2$.

As an example, to support service rate 2 048 kbit/s, the derived network frequency will be $f_{nx} = f_8 \times 19\,440 \times 2^{-6} \text{ kHz} = 2\,430 \text{ kHz}$. As a further example, the derived network frequency for a service rate of 34 368 kbit/s will be 38 880 kHz.

NOTE: This I-ETS does not imply that an actual implementation explicitly derive a clock at frequency f_8 and then, in turn, derive another clock at frequency f_{nx} by performing the multiplication by 19 440 and division by 2^k entailed in the stated formula for f_{nx} .

Administrations/Recognized Private Operating Agencies (RPOAs) may use existing network clocks to support national service in a non-SDH ATM network (e.g. 2 048 MHz).

4.7.2.2.4 Transport of the RTS

The 4-bit RTS is transmitted in the serial bit stream provided by the CSI bit in successive SAR-PDU headers. The modulo 8 SC provides a frame structure over 8 bits in this serial bit stream. Four bits of the framed 8 bits are allocated for the RTS and the remaining 4 bits are available for other uses. The SAR-PDU headers with the odd SC values of 1, 3, 5 and 7 are used for RTS transport. The MSB of the RTS is placed in the CSI bit of the SAR-PDU header with the SC of 1.

4.7.2.2.5 Plesiochronous network operation

The issue about the accommodation of plesiochronous operation (i.e. when a common reference clock is not available from the network) needs to be addressed. This scenario shall be accommodated in such a way that the recovered clock satisfies the jitter requirements specified in ITU-T Recommendations G.823 [4] and G.824 [5] for ITU-T Recommendation G.702 [1] signals. However, the detailed method of dealing with plesiochronous operation is not standardized.

4.7.2.2.3 Combination of SRTS and adaptive clock method

Optimum timing recovery can require an appropriate combination of the SRTS and the adaptive clock method.

4.7.2.3 SDT method

The CS procedure for SDT supports any fixed, octet-based structure. In particular, it supports 8 kHz based structures used in circuit mode services of ITU-T Recommendation I.231 [6]. When the structure size is greater than one octet, the CS procedure uses a pointer to delineate the structure boundaries.

The STRUCTURE parameter in the AAL-UNITDATA-REQUEST and AAL-UNITDATA-INDICATION primitives is used to convey structure information between the AAL and the AAL user. See subclause 4.1 for definition of primitives and parameters.

The 47 octet SAR-PDU payload used by the CS has two formats, called non-P and P format, as shown in figure 7:

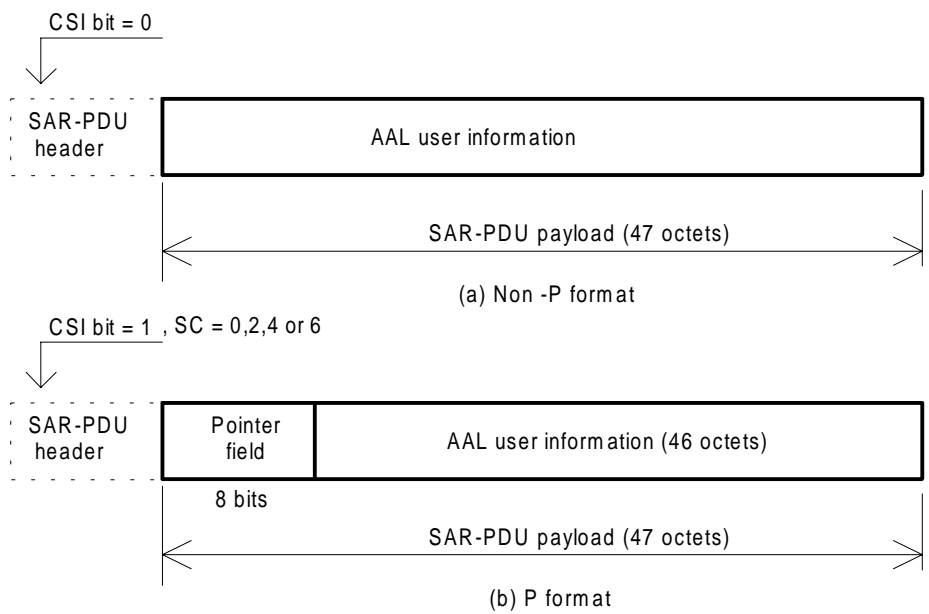

Figure 7: Format of SAR-PDU payload for SDT method

With SDT the blocking of AAL user information into SAR-PDU payloads at the sending AAL CS and the de-blocking of AAL user information from a SAR-PDU payload at the receiving AAL CS is required to:

- maintain the integrity of each AAL user octet transferred between the AAL CS and the AAL user by aligning each AAL user octet with a payload octet position;
- maintain the sequential order of the AAL user octet with the first AAL user octet in a payload assigned to the payload octet position adjacent to the SAR-PDU header (i.e. non-P format payload) or SDT header (i.e. P format payload).

When the block size value is "1" the SDT protocol generates only non-P format SAR-PDU payloads, since the preservation of octet integrity provides the necessary structure boundary information. For block sizes greater than "1", the SDT protocol requires the generation of a pointer (i.e. P format payload) to provide SDT block boundary information once in each eight SAR-PDUs payloads associated with a sequence count cycle.

a) operations of the non-P format:

- in the non-P format, the entire CS-PDU is filled with user information. This format is always used if the sequence count value in the SAR-PDU header is 1, 3, 5, or 7;

b) operations of the P format:

- the CS procedure only uses the P format when the block size is greater than one octet;
- in the P format, the first octet of the SAR-PDU payload is the pointer field. The remainder is filled with AAL user information. This format may be used only if the SC value in the SAR-PDU header is 0, 2, 4 or 6.

The format of the pointer field is shown in figure 8. The actual format of a SAR-PDU is indicated by the combination of the CSI bit and the SC; the CSI value "1" in combination with an even SC indicates the P format, the CSI value "0" or an odd SC indicates the non-P format.

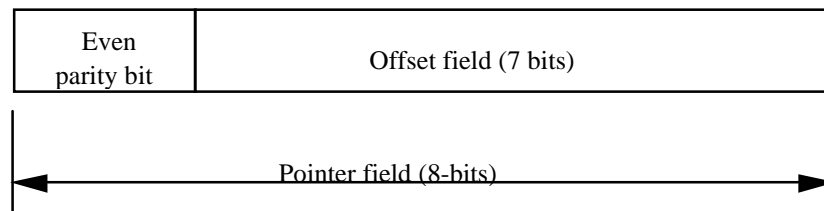

Figure 8: Pointer field format

The pointer field contains the binary value of the offset, measured in octets, between the end of the pointer field and the first start of the structured block in the 93 octet payload consisting of the remaining 46 octets of this SAR-PDU payload and the 47 octets of the next SAR-PDU payload. This offset ranges between 0 and 93 inclusive. The offset value 93 is used to indicate that the end of the 93 octet payload coincides with the end of a structured block whose start does not lie in the 93 octet payload. Moreover, the dummy offset value 127 is used when no structure boundary is being indicated.

The binary value of the offset is inserted right justified in the offset field, i.e. the least significant bit of the offset is transmitted last. The first bit of the pointer field is used to provide an even parity check over the pointer field.

The P format is used exactly once in every cycle, where a cycle is the sequence of eight consecutive SAR- PDUs with sequence count values 0 through 7. The P format is used at the first available opportunity in a cycle to point to a start of a structure boundary. If neither a start of a structure boundary nor an end of a structure boundary is present in a cycle, then the P format with the dummy offset value in the pointer field is used at the last opportunity in the cycle, i.e. SAR-PDU with sequence count value 6.

If a start of a structure boundary is not present in a cycle but coincides with the beginning of the next cycle, then the P format with offset value 93 in the pointer field is used in the SAR-PDU with sequence count value 6 and the P format with offset value 0 in the pointer field is used in the SAR-PDU with sequence count value 0 in the next cycle.

In keeping with the above pointer rule, the first structured block to be transmitted after the AAL connection is established uses the P format with SC value in the SAR-PDU header equal to 0 and with the first octet of the structured data placed in the second octet of the SAR-PDU payload.

4.7.2.4 Correction methods for bit errors and/or cell losses

Three correction methods are described:

- correction method for bit errors;
- correction method for bit errors and cell losses without delay restrictions;
- correction method for bit errors and cell losses with delay restrictions.

4.7.2.4.1 Correction method for bit errors

This correction method makes use of Reed-Solomon (128, 124) codes which are able to correct up to 2 errored symbols (octets). Reed-Solomon codes to be used are built over Galois Field (256), and the generator polynomial is given by

$$\prod_{i=0}^3 (x - \alpha^{i+k}),$$

where α is a root of the binary primitive polynomial $x^8 + x^7 + x^2 + x + 1$, and k is the base exponent of the generator polynomial with $k = 120$.

In the transmitting CS, the 4 octet Reed-Solomon code is appended to 124 octets of incoming data from the upper layer. See figure 9 for the structure and the format of the FEC block.

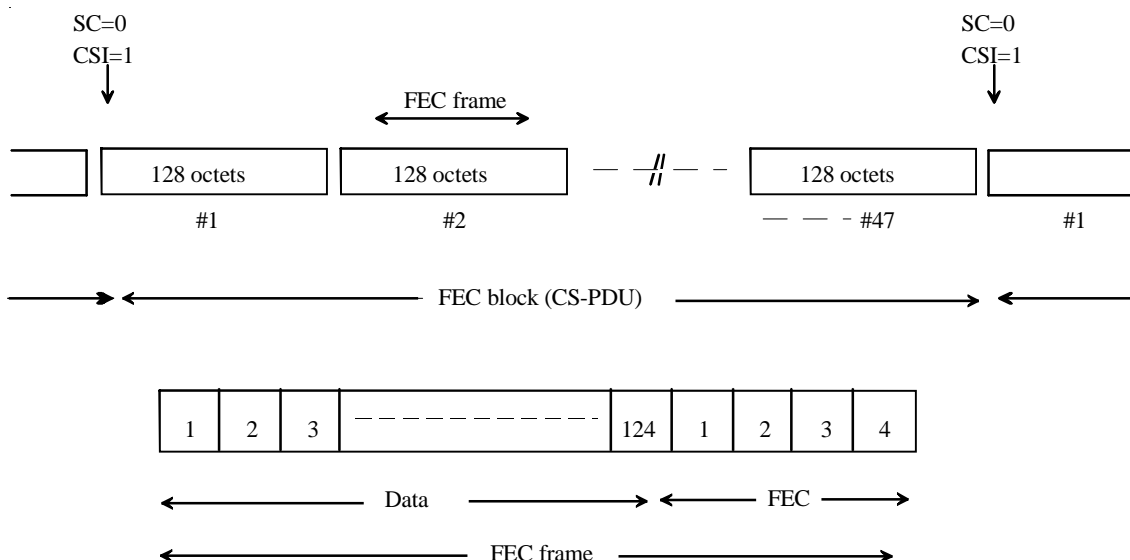

Figure 9: Structure and format of a FEC block

A FEC block is organized as a group of 47 consecutive FEC frames. Each FEC frame contains 128 octets, i.e. the FEC block has $128 \times 47 = 6\ 016$ octets. Such FEC block constitutes one CS-PDU.

For the synchronization of the CS-PDU, the CS indicator bit of the SAR-PDU header is set to 1 for the first SAR-PDU payload and is set to 0 for the remaining SAR-PDUs of the CS-PDU. This use of the CS indication bit precludes the use of the SDT method as specified in 4.7.2.3.

This method can perform the following correction:

- 2 errored octets in each FEC frame if there is no cell loss.

This method is applicable when only cell loss detection is needed and there is no cell correction. Cell loss detection implies the insertion of 47 consecutive dummy octets. Misinserted cells which have been detected are merely discarded in the CS.

The overhead of this method is 3,1 % and the delay is approximately 3 cells at the receiver.

4.7.2.4.2 Correction method for bit errors and cell losses without delay restrictions

This correction method combines FEC and octet interleaving, from which a CS-PDU structure is defined. FEC uses a Reed-Solomon (128, 124) code which is able to correct up to 2 errored symbols (octets) or 4 erasures in the block of 128 octets. An erasure is an errored octet whose location in the block is known. Reed-Solomon codes to be used are built over Galois Field (256), and the generator polynomial is given by:

$$\prod_{i=0}^3 (x - \alpha^{i+k}),$$

where α is a root of the binary primitive polynomial $x^8 + x^7 + x^2 + x + 1$, and k is the base exponent of the generator polynomial with $k = 120$. In the transmitting CS, the 4 octet Reed-Solomon code is appended to 124 octets of incoming data from the upper layer. The resulting 128 octet long blocks are then forwarded to the octet interleaver. See figure 10 for the format of the interleave matrix.

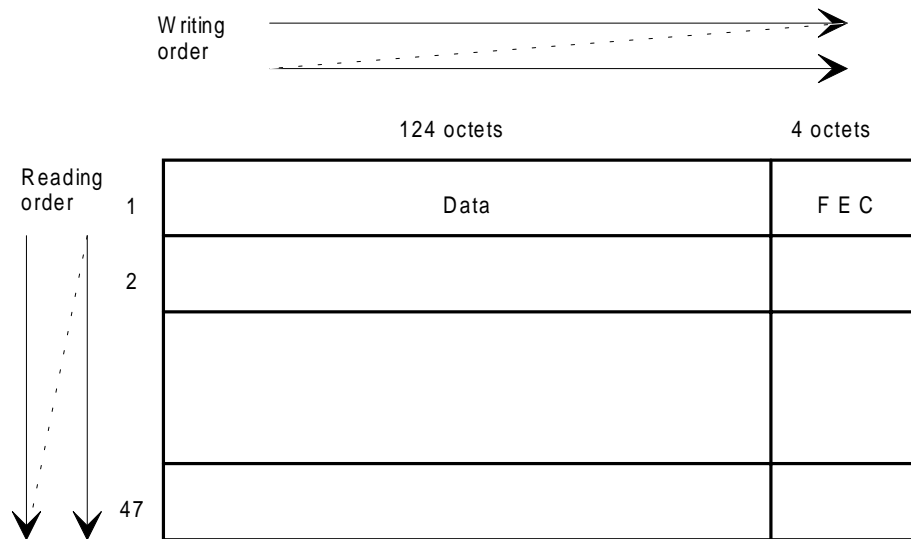

Figure 10: Structure and format of the long interleaver matrix

The octet interleaver is organized as a matrix of 128 columns and 47 rows. In the transmitting CS entity, the interleaver is used as follows: at the input, incoming 128 octet long blocks are stored row by row (one block corresponding to one row); at the output, octets are read out column by column. The matrix has $128 \times 47 = 6\,016$ octets, corresponding to 128 SAR-PDU payloads. These 128 SAR-PDU payloads constitute one CS-PDU.

In this process, the loss of one SAR-PDU payload in the matrix implies one erasure to correct in each row of the matrix. Erasures correspond to dummy cell payloads inserted in the cell flow when a cell loss has been detected. Misinserted cells which have been detected are merely discarded in the CS.

For the synchronization of the CS-PDU, the CSI bit of the SAR-PDU header is set to 1 for the first SAR-PDU payload of the CS-PDU. This use of the CSI bit precludes the use of the SDT method as specified in subclause 4.7.2.3.

Within any CS-PDU matrix, this method can perform the following corrections:

- 4 cell losses, at identified location; or
- 2 cell losses and 1 errored octet in each row; or
- 2 errored octets in each row if there is no cell loss.

The overhead of this method is 3,1 %, and the delay is 128 cells both at the sending and at the receiving side.

4.7.2.4.3 Correction method for bit errors and cell losses with delay restrictions

a) Characteristics of the method

This correction method combines FEC using Reed-Solomon codes and octet interleaving of data. The size of the interleaver is 16 cells, the interleaving matrix has 8 rows and 94 columns. The method utilizes Reed-Solomon (94, 88) codes. The erasure mode is used for the correction of dummy octets corresponding to cell loss locations. Reed-Solomon codes to be used are built over Galois Field (256), and the generator polynomial is given by:

$$\prod_{i=0}^5 (x - \alpha^{i+k}),$$

where α is a root of the binary primitive polynomial $x^8 + x^7 + x^2 + x + 1$, and k is the base exponent of the generator polynomial with $k = 120$.

A diagonal interleaving mechanism is used to decrease the processing delay of the method. In the interleaver, the writing mode and the reading mode are alternate. The process in the interleaver is continuous, i.e. only one interleaver is necessary at each end. See figure 11 for structure of the short interleaver matrix.

	88 octets	6 octets
1	Data	FEC
2		
3		
4		
5		
6		
7		
8		

Figure 11: Structure of the short interleaver matrix

b) Operations at the transmitting end

RS codes for a row are calculated prior to writing in the interleaver. The writing order in the interleaver is horizontal. The reading order is diagonal. The process is operated octet by octet. Let $a(i, j)$ be a coefficient (i.e., an octet) in the matrix, where i is the row number and j the column number. Then the sequence of coefficients to be read out of the matrix diagonally is as follows:

$\dots, a(i + 1, j - 1), a(i, j), a(i - 1, j + 1), \dots$

The format and organization of the interleaver is given in figure 12.

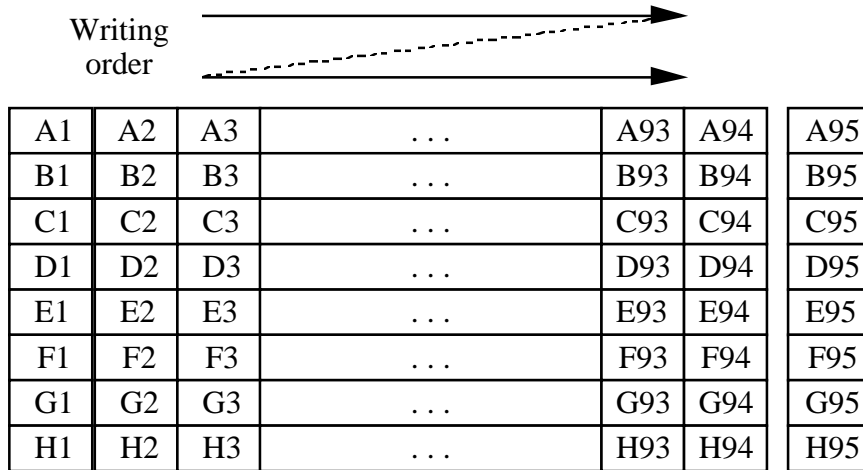

Figure 12: Format and organization of the short interleaver matrix

For a correct reading order of the diagonal mechanism, a virtual column is added (number 95). It is used only for counting, it does not contain any information and it is not transmitted. It is mentioned in "parentheses" in the following sequences only to permit a good understanding of the reading order. Examples of 47 octets sequences that are read out of the interleaver are given hereafter:

...

seq. k: (B95), A1, H2, G3, ..., A9, H10, ..., A17, ..., A25, ..., A33, ..., A41, ..., C47.

seq. k + 1: B48, A49, H50, ..., B56, ..., B64, ..., B72, ..., B80, ..., B88, ..., D94

seq. k + 2: (C95), B1, A2, H3, G4, ..., B9, ..., B17, ..., B25, ..., B33, ..., B41, ..., D47.

seq. k + 3: C48, B49, A50, ..., C56, ..., C64, ..., C72, ..., C80, ..., C88, ..., E94.

seq. k + 4: (D95), C1, B2, ..., C9, ..., C17, ..., C25, ..., C33, ..., C41, ..., E47.

...

1) Operation at the beginning of the communication:

At the beginning of the communication, the reading of the interleaver begins, before it is completely filled up. The reading process begins as soon as the first octet has been written in the interleaver. As a result, in the first SAR-PDUs of the communication, only some octets carry valid information. Other octets contain dummy information as they correspond to positions in the interleaver which have not yet been filled. The communication begins as follows (x: dummy octets):

1st SAR-PDU: A1, x...x, A9, x...x, A17, x...x, A25, x...x, A33, x...x, A41, x...x.

2nd SAR-PDU: x, A49, x...x, A57, x...x, A65, x...x, A73, x...x, A81, x...x, A89, x...x.

3rd SAR-PDU: B1, A2, x...x, B9, x...x, A10, x...x, B17, A18, , x...x, B25, A26, , x...x, B33, A34, x...x, B41, A42, x...x.

The first SAR-PDU to be completed with valid octet is number 15.

2) Operation at the end of the communication:

At the end of the communication, the transmitting interleaver is read out until it gets completely empty. Some data of the transmitting interleaver will be transmitted twice, which has no action in the receiving interleaver where they will be stored a second time in positions that have already been read out, and which will be interpreted as dummy positions.

c) Operation in the receiving end:

The mechanism in the receiving interleaver is the inverse of that of the transmitting interleaver, i.e. the writing order is diagonal and the reading order is horizontal. For the reading, the rule is the following: when the interleaver has been filled up with 14 SAR-PDUs, then the reading process is started for the first row.

d) Delineation of the interleaver

As the process is continuous in the interleaver, there is no real start of the interleaver. Only the even or odd value of the sequence number is necessary in the receiving CS to know if the corresponding SAR-PDU begins respectively with a coefficient numbered 1 or with a coefficient numbered 48.

e) Performance

Correction capabilities of this method are:

- one cell loss occurrence in the group of 16 cells;
- 3 errored octets in a row of 94 octets.

The overhead of the method is 6,38 %.

Processing delay imposed by this method is as follows:

The following calculation of the processing delay takes into account both the transmitting and the receiving ends. Let D be the processing delay corresponding to a horizontal/vertical processed interleaver. Due to the diagonal mechanism, for a given row of the interleaver, the distribution of the delay is the following:

- for the first octet of the interleaver the delay is approx. null in the transmitter and approx. D in the receiver;
- for the last octet of the interleaver the delay is approx. D in the transmitter and approx. null in the receiver.

As a result, for a given octet the total delay is D . Examples of values are given for the total processing delay. Processing delays are: 14,7 ms for 384 kbit/s, 3,67 ms for 1 536 kbit/s, 2,93 ms for 1 920 kbit/s.

4.7.2.5 Partially filled cell method for control of SAR-PDU payload assembly delay

This method defines a CS procedure for partially filling the payload of a SAR-PDU to reduce payload assembly delay. The method may be of use with delay sensitive CBR services. The procedure assumes that AAL-user information occupies the leading octets of the payload except for octets used for CS overhead (e.g. SDT pointer). The procedure assumes that other active AAL CS functions generating overhead are defined so the receiving AAL CS knows when the payload contains overhead, the number of overhead octets and the position of these octets in the payload. The partial fill procedure determines the number and position of AAL-user information octets and CS generated dummy value octets in the remaining payload octets.

The number of AAL-user information octets in the SAR-PDU payload, N ($N < 47$) shall be determined from the maximum SAR-PDU payload assembly delay. Given a value for N , the procedure for assembling the SAR-PDU payload is:

If no AAL type 1 CS protocol procedures introduce overhead into the SAR-PDU payload, then the number of AAL-user octets is N and the leading octets in the SAR-PDU payload are used for the AAL-user information as shown in figure 13 (a).

If AAL type 1 CS protocol procedures introduce overhead of C octets ($C \leq 47$) into the SAR-PDU payload (e.g. SDT), then the specified SAR-PDU payload octets are reserved for the CS overhead. The leading octets of the SAR-PDU payload, except for octets reserved for CS overhead, are again used for AAL-user information as shown in figure 13 (b).

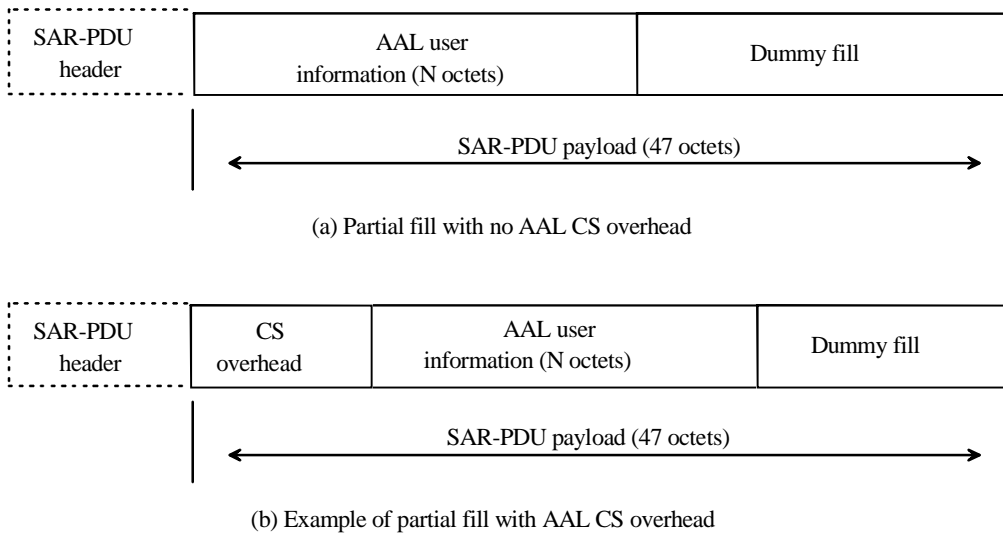

Figure 13: Format of partially filled SAR-PDU payload

Due to the introduction of CS overhead, two possible conditions exist with regard to SAR-PDU payload AAL-user information capacity:

- 1) If $N + C \leq 47$, N octets can be used for AAL-user information;
- 2) If $N + C > 47$, less than N octets can be used for AAL-user information.

When the CS overhead and number of AAL-user information octets in the SAR-PDU payload never exceeds 47 (i.e. condition (1) always applies), the number of AAL-user information octets in SAR-PDU payloads is always N and the payload assembly delay is constant for all SAR-PDUs generated. Current CS procedures which may be combined with partial fill, such as SDT, only result in SAR-PDU payloads satisfying condition (1). When SAR-PDU payloads satisfying condition (2) may exist due to the introduction of CS procedures where $N + C > 47$, further study would be required.

If the number of SAR-PDU payload octets reserved for CS overhead and AAL-user information is less than 47, then the remaining payload octets assume a dummy value generated by the AAL CS (see note). At the receiving AAL entity, the CS shall not pass the payload octets with dummy values to the AAL-user.

NOTE: The value of the SAR-PDU dummy octets generated by the AAL-CS for the control of payload assembly delay is to be specified.

Annex A (informative): Illustration of the data unit naming convention

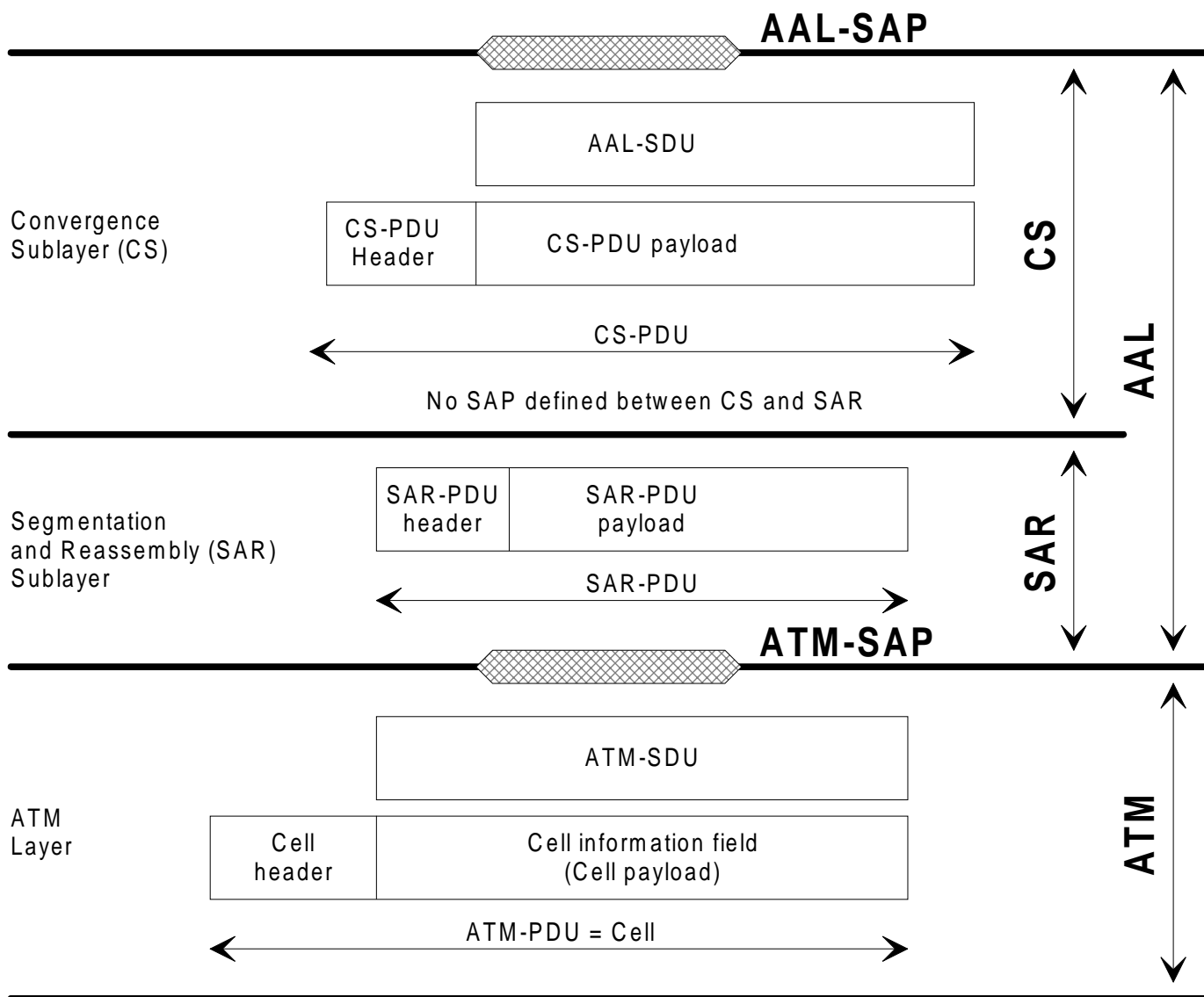

NOTE: AAL type 1-PCI consists of the SAR-PDU header and the conditional CS-PDU header (pointer).

Figure A.1: Data unit naming conventions for the AAL type 1

Annex B (informative): Encoding and information transfer principles

B.1 Cell payload field encoding

The encoding of the 384-bit/48-octet payload is defined relative to the cell header using the following conventions.

- 1) Bit positions in the 384-bit cell payload are located with respect to the cell header:
 - the first bit position in the cell payload is adjacent to the cell header and designated payload bit "1";
 - the last bit position in the cell payload is designated payload bit "384";
- 2) Octet positions in the 48-octet cell payload are located with respect to the cell header:
 - the first octet position in the cell payload is adjacent to the cell header (i.e. payload bit positions 1 - 8) and designated payload octet "1";
 - the last octet position in the cell payload (i.e., payload bit positions 377 - 384) is designated payload octet "48".
- 3) Bits within a specified payload octet are oriented with respect to the cell header:
 - the most significant bit (i.e., 2^7) position is the bit position nearest to the cell header which is designated bit "8";
 - the least significant bit position (i.e., 2^0) is the bit position furthest from the cell header which is designated bit "1".

Figure B.1 illustrates the encoding principles.

The orientation of bits/octets within a cell payload field/subfield follows the convention for orienting bits in a payload octet when the cell payload field/subfield has multiple bits and the payload octet convention for orienting octets when the cell payload field/subfield has multiple octets.

- The most significant bit position of a cell payload field/subfield is the bit position nearest to the cell header and the last significant bit position of a cell payload field/subfield is the bit position furthest from the cell header when describing bit orientation.
- The first octet position of the field/subfield is the octet position nearest to the cell header and the last octet position of the field/subfield is the octet furthest from the cell header when describing octet orientation.

B.2 AAL user information transfer

The writing and reading of AAL user information into and out of the cell payloads by the AAL adopts a first-in/first-out (FIFO) convention. This convention coupled with the assumption of sequential integrity of information transfer by the ATM layer (i.e. cell sequence integrity) preserves the sequential integrity of AAL user information.

- 1) At the sending AAL-entity during cell payload assembly:

The first bit (octet) received from the AAL user for the cell payload is assigned to the payload bit (octet) position nearest the cell header reserved for AAL user information. The other bits (octets) received from the AAL user are sequentially assigned to payload bit (octet) positions in ascending order until the highest payload bit (octet) position reserved for AAL user information is filled.

- 2) At the receiving AAL-entity during cell payload dis-assembly:

The bits (octets) of AAL user information in a cell payload are passed to the AAL user sequentially in ascending order beginning with the bit (octet) of AAL user information occupying the payload bits (octets) position nearest the cell header.

Cell payload bit/octet positions

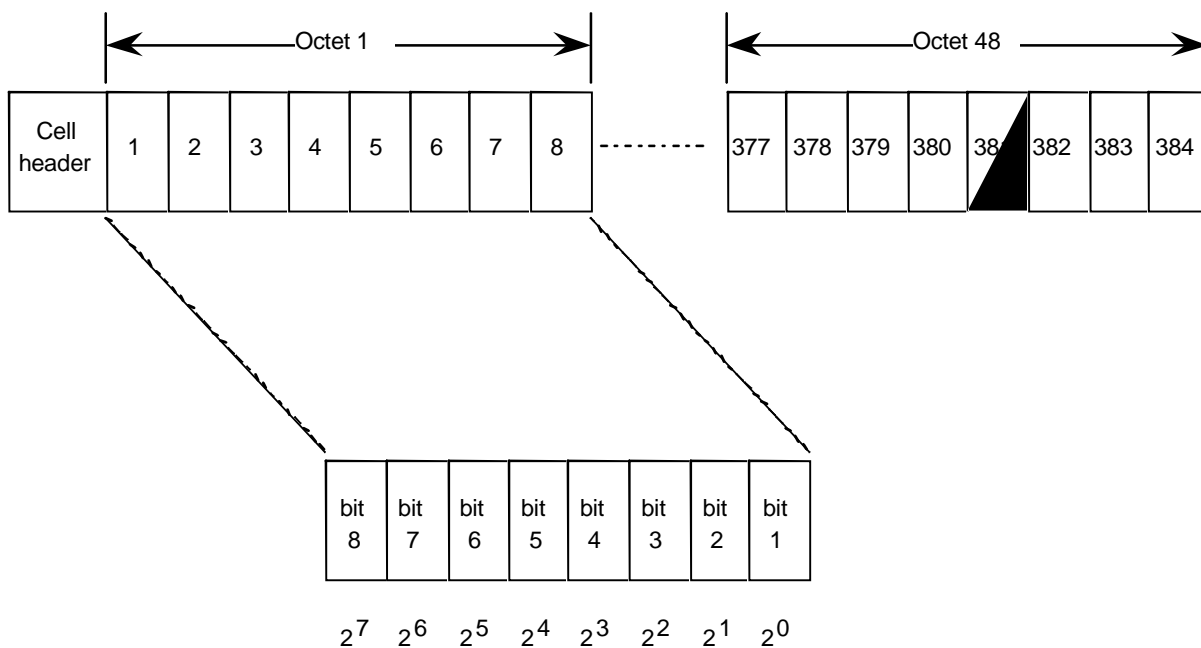

Bit orientation within an octet

Figure B.1: Encoding principles

Annex C (informative): Functional model for the circuit transport with AAL type 1

C.1 Functional model of the SAR

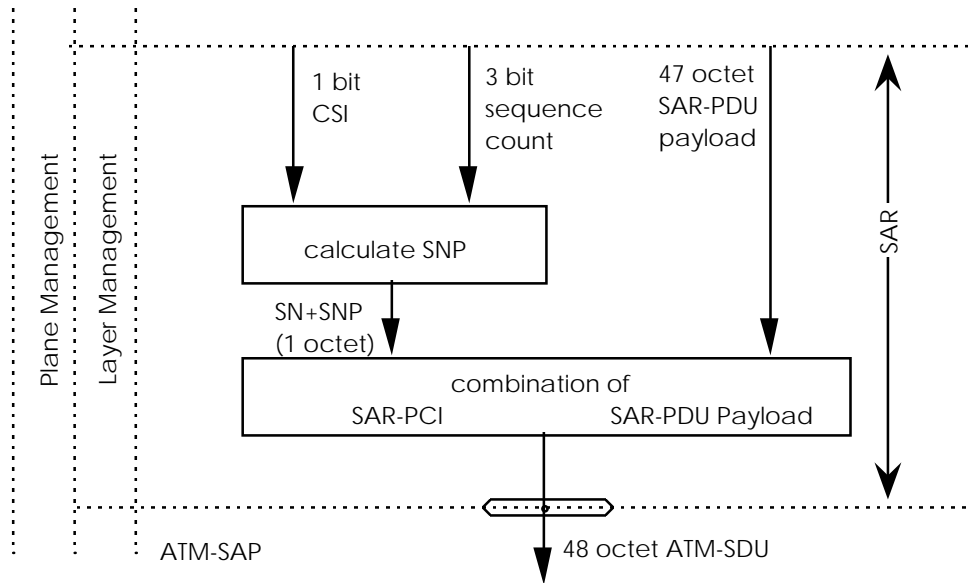

Figure C.1: Functional model of the SAR at the transmitting side

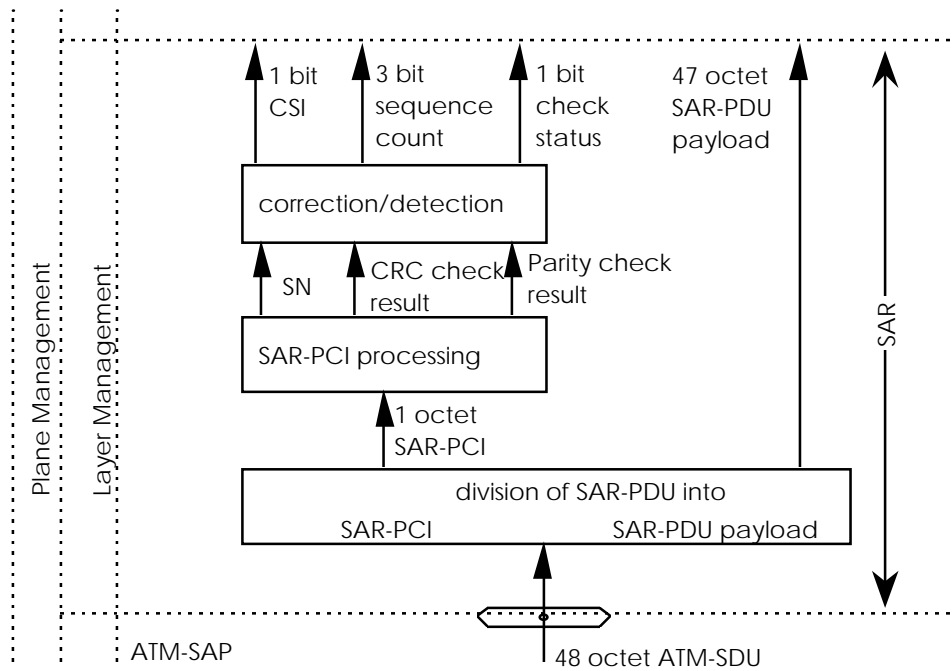

Figure C.2: Functional model of the SAR at the receiving side

C.2 SDL of the SAR

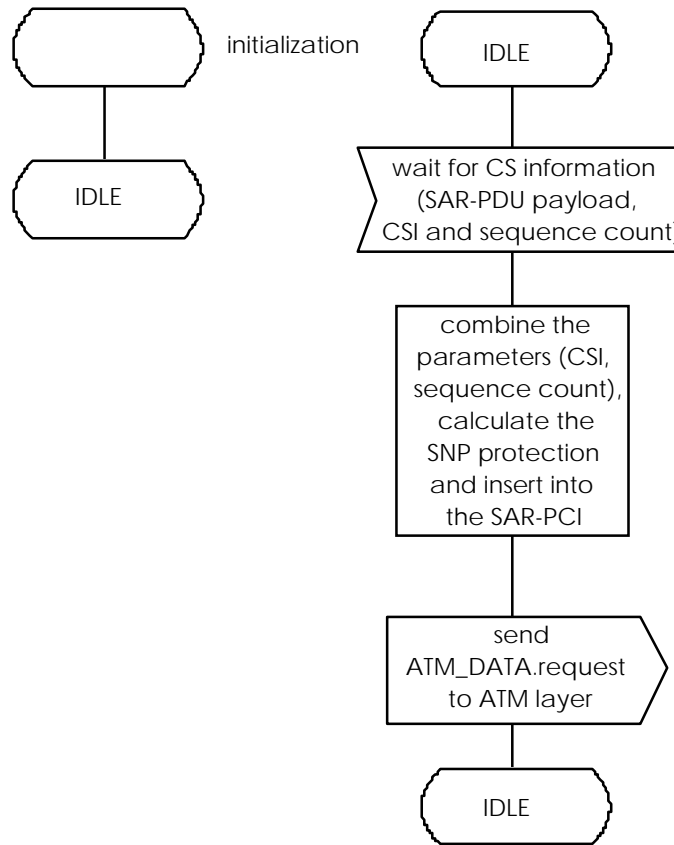

Figure C.3: SDL of SAR transmitter

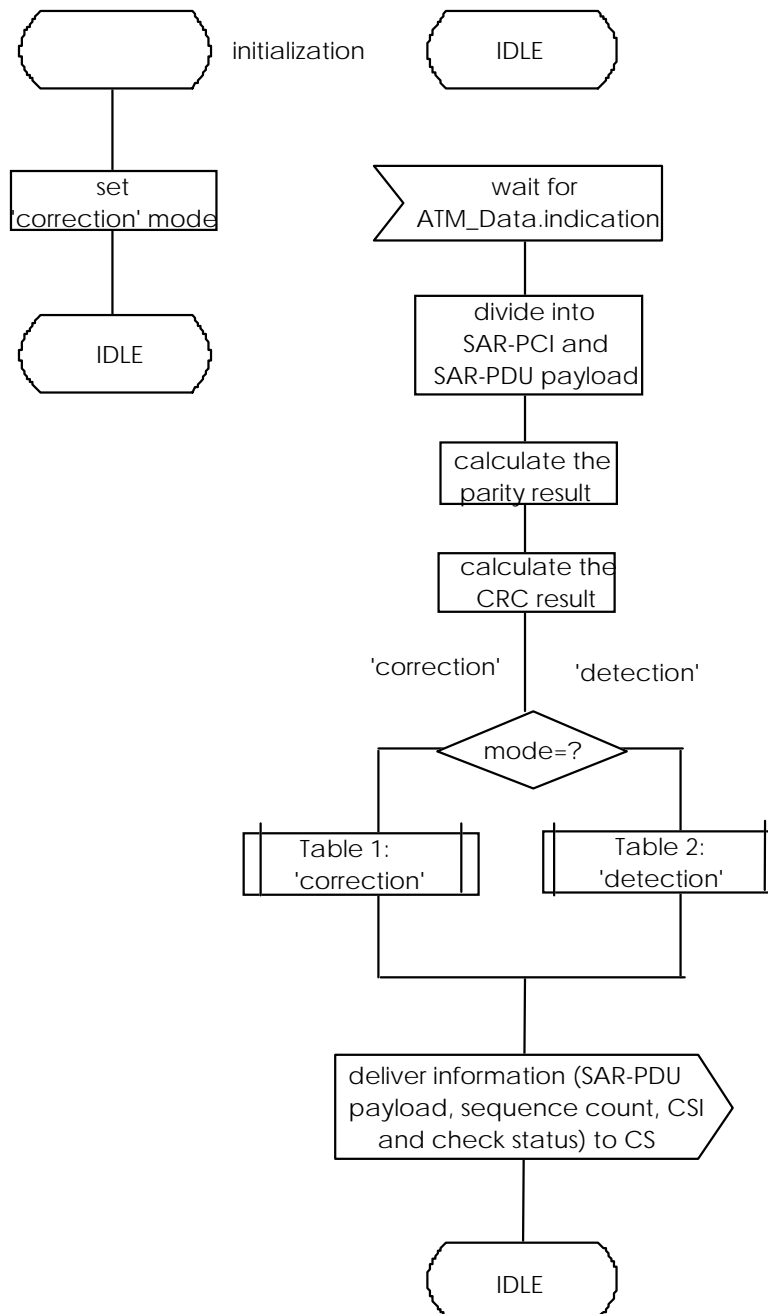

Figure C.4: SDL of SAR receiver

Annex D (informative): Parameters for AAL type 1 protocol

In order to facilitate further work on a detailed procedure description for a specific higher layer, this annex gives informative and example parameters, i.e., a set of procedures and options, for some specific AAL type 1 services. It should be noted that:

- 1) the following description is intended to give informative material only;
- 2) not all AAL type 1 services are listed;
- 3) the use of parameters other than those described is not precluded; and
- 4) use of certain parameters is not illustrated.

Further detailed parameters can be defined, where necessary and appropriate, with respect to a specific higher layer in an associated Recommendation.

D.1 Circuit transport

D.1.1 Transport of digital channel supported by 64 kbit/s-based ISDN

- a) Transport of 64 kbit/s channel
 - CBR rate at AAL service boundary: 64 kbit/s
 - Source clock frequency recovery: Synchronous
 - Error correction method: Not used
 - Error status indication at the receiver: Not used
 - Pointer: Not used
 - Partially fill cell method: Not used
- b) Transport of 384, 1 536 or 1 920 kbit/s channel
 - CBR rate at AAL service boundary: 384, 1 536 or 1 920 kbit/s
 - Source clock frequency recovery: Synchronous
 - Error correction method: Not used
 - Error status indication at the receiver: Not used
 - Pointer: Used (note)
 - Partially fill cell method: Not used

NOTE: Pointer is mandatory to support 8 kHz integrity for 64 kbit/s-based ISDN services at rates greater than 64 kbit/s, i.e., a demarcation of 6 (384 kbit/s), 24 (1 536 kbit/s) and 30 (1 920 kbit/s) octets per 125 μ s.

D.1.2 Transport of G.702 PDH circuit

For this example, it is important to distinguish the clock operation mode at the AAL service boundary, i.e., service clock, with respect to a network clock. Asynchronous circuit transport provides transport of signals from CBR sources whose clocks are not frequency-locked to a network clock. Synchronous circuit transport provides transport of signals from CBR sources whose clocks are frequency-locked to a network clock. Whether it is synchronous or asynchronous will depend on the service provided by the specific network.

- a) Synchronous circuit transport
 - CBR rate at AAL service boundary: Note
 - Source clock frequency recovery: Synchronous
 - Error correction method: Not used
 - Error status indication at the receiver: Not used
 - Pointer: Not used
 - Partially fill cell method: Not used

NOTE: Example bit rates are 2 048, 8 448, and 34 368 Mbit/s as defined in ITU-T Recommendation G.702 [1].

- b) Asynchronous circuit transport
- CBR rate at AAL service boundary: (note 1);
 - Source clock frequency recovery: Asynchronous (note 2);
 - Error correction method: Not used;
 - Error status indication at the receiver: Not used;
 - Pointer: Not used;
 - Partially fill cell method: Not used.

NOTE 1: Example bit rates are 2 048, 8 448, and 34 368 Mbit/s as defined in ITU-T Recommendation G.702 [1].

NOTE 2: There are two clock recovery methods for asynchronous circuit transport, adaptive clock or SRTS method. The adaptive clock method supports circuit transport application where control of wander can be relaxed (see subclause 4.7.2.2.1). The SRTS method supports circuit transport application where control of jitter and wander is necessary (see subclause 4.7.2.2.2). The need to control wander is not determined solely by the applications supported, but also by the points of AAL connection termination (e.g., CPE to CPE termination, network to network termination, CPE to network termination).

D.1.3 Transport of G.707 SDH circuit

This example illustrates circuit transport of ITU-T Recommendation G.707 [2] SDH signals.

- a) Transport of TU-12
- CBR rate at AAL service boundary: 2 304 kbit/s;
 - Source clock frequency recovery: Synchronous;
 - Error correction method: Not used;
 - Error status indication at the receiver: Not used;
 - Pointer: Used (note);
 - Partially fill cell method: Not used.

NOTE: Pointer is mandatory to indicate V1 byte of TU-12.

D.2 Video signal transport

- a) Distributive television services

This example illustrates transport of distributive television signals encoded by using MPEG2 with a constant bit rate, as described in ITU-T Recommendation J.82 [9].

- CBR rate at AAL service boundary: Depending on MPEG2 parameters;
- Source clock frequency recovery: Asynchronous (note 1);
- Error correction method: Used (procedure of subclause 4.7.2.4.2) (note 2);
- Error status indication at the receiver: Used;
- Pointer: Not used;
- Partially fill cell method: Not used.

NOTE 1: The adaptive clock method is used (See subclause 4.7.2.2.1).

NOTE 2: This method can perform correction of, e.g., 4 cell losses within 128 cells. Detailed performances are given in subclause 4.7.2.4.2.

b) Conversational services of bit-rates higher than primary rates

This example illustrates transport of interactive video signals for, e.g., video-telephony and conference application, as specified in ITU-T Recommendation H.310 [10].

- CBR rate at AAL service boundary: Depending on H.310 parameters;
- Source clock frequency recovery: Synchronous/Asynchronous per H.310;
- Error correction method: Used or Not used per H.310 (note);
- Error status indication at the receiver: Used or Not used per H.310;
- Pointer: Not used;
- Partially fill cell method: Not used.

NOTE: No error correction method is used in an error free environment or a situation where a higher layer does not need correction of cell losses and/or bit errors. Error correction methods as described in subclause 4.7.2.4 may be used in an error prone environment or a situation where a higher layer needs correction of cell losses and/or bit errors.

c) Conversational services of px64 kbit/s signals

This example illustrates transport of interactive video signals of the px64 video-telephony and video-conference applications as specified in ITU-T Recommendations H.320 [11] and H.321 [12].

- CBR rate at AAL service boundary: 384, 1 536 or 1 920 kbit/s (note 1);
- Source clock frequency recovery: Synchronous;
- Error correction method: Used or Not used (note 2);
- Error status indication at the receiver: Not used;
- Pointer: Not used (note 3);
- Partially fill cell method: Not used.

NOTE 1: The example bit rates are those supported in the 64 kbit/s-based ISDN by using H0, H11, H12, respectively.

NOTE 2: No error correction method is used in an error free environment or a situation where a higher layer does not need correction of cell losses and bit errors. Error correction methods as described in subclause 4.7.2.4 may be used in an error prone environment or a situation where a higher layer needs correction of cell losses and/or bit errors.

NOTE 3: ITU-T Recommendation H.221 [13], as a part of ITU-T Recommendation H.320 [11], provides bit-by-bit synchronization, hence it does not need support of 8 kHz integrity.

D.3 Voiceband signal transport

This example illustrates transport of 64 kbit/s A-law or μ -law coded ITU-T Recommendation G.711 [3] signals.

- CBR rate at AAL service boundary: 64 kbit/s;
- Source clock frequency recovery: Synchronous;
- Error correction method: Not used;
- Error status indication at the receiver: Not used;
- Pointer: Not used;
- Partially fill cell method: Not used.

NOTE: Care should be taken to minimize delay at the receiver for alleviating echo performance problem. See subclause 4.7.1.3 for detailed description.

Annex E (informative): Algorithm to detect lost and misinserted cells in AAL 1

This annex provides examples for handling of lost/misinserted cells and for maintaining bit count integrity. Two algorithms for SN processing are given. Both algorithms detect lost cells. In addition, one algorithm detects misinserted cells while the other algorithm imposes no inherent processing delay and is thus suitable for delay sensitive applications. Both algorithms have to be supplemented by mechanisms to maintain bit count integrity for the replacement of lost information e.g. via dummy cells as described in subclause 4.7.2.4.

E.1 General

Examples of algorithms for the processing of the Sequence Number in AAL 1 are given. Two different algorithms are described: a robust algorithm, in which the decision to accept a cell is taken after the arrival of the next cell; and a fast algorithm, in which the decision to accept the cell is taken immediately after arrival of the cell. Potential problems due to the delay in waiting for the next cell, which arise with low bit rate services, are avoided by the fast SN algorithm. On the other hand the robust algorithm is able to distinguish between lost and misinserted cells and thus may be more useful for applications which are sensitive to misinserted cells.

E.2 Indications from the SAR sublayer

The SAR sublayer provides the following inputs to the CS, concerning the SN field:

- a) the value of the SC (3 bits);
- b) the value of the CS indication (CSI) in the SN field (1 bit);
- c) the check status (valid or invalid) of the SN field.

Only indications a) and c) are used by the algorithms to determine lost/misinserted cells.

E.3 Capabilities of the algorithms

Both algorithms have the following capabilities:

- detect a maximum of 6 consecutive lost cells;
- do not unnecessarily discard a cell with an invalid SN field.

In addition, the robust SN algorithm identifies and discards a single misinserted cell.

E.4 The algorithms

A simplified comparison of the two algorithms is given in figure E.1. The algorithms are described by a common state machine with five states, as shown in figure E.2. An evolution in the state machine is indicated by an arc, on which there are two distinct values represented. The first value refers to the event that originates the evolution in the state machine, and the second value refers to an action to be taken as a result of the event.

E.4.1 Robust SN Algorithm

A decision in this algorithm is taken after the analysis of two consecutive SN. This means that when a cell is received it is stored, waiting for the next one before it is eventually passed to the final destination. In the state machine the action always refers to the stored cell.

A valid SN is defined as an SN which has no detected errors or had an error that was corrected.

The details of the algorithm are the following:

- a) **START;**
 - It is the initial state. It remains in this state discarding the cells until there is a valid SN;
- b) **OUT OF SYNC;**
 - In this state the sequence counting is not synchronized yet. It waits for an SC that is in sequence with the previous one. When it occurs, the stored cell is accepted by the system. If a cell with an invalid or out of sequence SN is received the system returns to START and the stored cell is discarded;
- c) **SYNC;**
 - In this state the sequence counting is considered to be synchronized:
 - if the SC is in sequence with the previous one it remains in this state and the stored cell is accepted;
 - if the SN is invalid, it goes to INVALID, but the stored cell is accepted;
 - if the SC is not in sequence with the previous one, it goes to OUT OF SEQUENCE, accepting the stored cell;
- d) **INVALID;**
 - In this state the system shall take a decision on the stored cell with the invalid SN, when it receives the next cell:
 - if the SN is again invalid, the system returns to START and the stored cell is discarded;
 - if the SN is valid and the SC is in sequence with the last cell received with a valid SN the system returns to SYNC, but the stored cell is considered to be misinserted and it is discarded;
 - if the SN is valid but the SC has a value exceeding by two the SC of the last cell received with a valid SN, it is assumed that although there was an invalid SN the stored cell is in sequence and therefore it is accepted. It returns to SYNC;
 - if the SN is valid but is not in any of the previous situations, it discards the stored cell and goes to OUT OF SYNC;
- e) **OUT OF SEQUENCE;**
 - In this state the following actions are taken when a cell arrives:
 - if the SN is invalid, it discards the stored cell and it goes to START;
 - if the SN is valid and the SC is in sequence with the last cell received prior to the stored one, the system returns to SYNC, but the stored cell is considered to be misinserted and is discarded;
 - if the SN is valid and the SC is in sequence with the SC of the stored cell, the system assumes that cells were lost; it inserts a number of dummy cells identical to the number of lost cells, accepts the stored cell and returns to SYNC;
 - if the SN is valid and the SC has a value exceeding by two the SC of the last cell received prior to the stored cell the system assumes that the stored cell was in sequence (i.e., the SN error protection mechanism failed) and therefore it accepts the stored cell and returns to SYNC;
 - if the SN is valid but is not in any of the three previous situations, it discards the stored cell and goes to OUT OF SYNC.

E.4.2 Fast SN Algorithm

A decision in this algorithm is taken immediately after the analysis of the received cell. This means that when a cell is received the SN is immediately evaluated and the cell is eventually passed to the final destination. In the state machine the action always refers to the last cell received.

A valid SN is defined as an SN which has no detected errors or it had an error that was corrected.

The details of the algorithm are the following:

- a) **START;**
 - It is the initial state. It remains in this state discarding the cells until there is a valid SN;
- b) **OUT OF SYNC;**
 - In this state the sequence counting is not synchronized yet. It waits for an SC that is in sequence with the previous one. When it occurs, the received cell is accepted by the system. If a cell with an invalid or out of sequence SN is received the system returns to START and the received cell is discarded;
- c) **SYNC;**
 - In this state the sequence counting is considered to be synchronized:
 - if the SC is in sequence with the previous one it remains in this state and the received cell is accepted;
 - if the SN is invalid, it goes to INVALID, but the received cell is accepted;
 - if the SC is not in sequence with the previous one, it goes to OUT OF SEQUENCE, accepting the received cell;
- d) **INVALID;**
 - In this state the system shall take the following decisions on the received cell:
 - if the SN is again invalid, the system returns to START and the received cell is discarded;
 - if the SN is valid and the SC is in sequence with the last cell received with a valid SN the system returns to SYNC, but the received cell is discarded to keep bitcount integrity because the previous cell is considered to be misinserted but is already sent;
 - if the SN is valid and the SC has a value exceeding by two the SC of the last cell received with a valid SN, it is assumed that although there was an invalid SN the received cell is in sequence and therefore it is accepted. It returns to SYNC;
 - if the SN is valid but is not in any of the previous situations, it discards the received cell and goes to OUT OF SYNC;
- e) **OUT OF SEQUENCE;**
 - In this state the following actions are taken when a cell arrives:
 - if the SN is invalid, it discards the received cell and it goes to START;
 - if the SN is valid and the SC is in sequence with the last cell received in sequence, the system returns to SYNC, but the received cell is discarded to keep bit count integrity because the previous cell is considered to be misinserted but is already sent;
 - if the SN is valid and the SC is in sequence with the SC of the previous cell, the system assumes that cells were lost; it inserts a number of dummy cells identical to the number of lost cells, accepts the received cell and returns to SYNC;

- if the SN is valid and the SC has a value exceeding by two the SC value of the last cell received in sequence (i.e., the SN error protection mechanism failed) the system assumes that the received cell was in sequence and therefore it accepts the received cell and returns to SYNC;
- if the SN is valid but is not in any of the three previous situations, it discards the received cell and goes to OUT OF SYNC.

Robust SN Algorithm

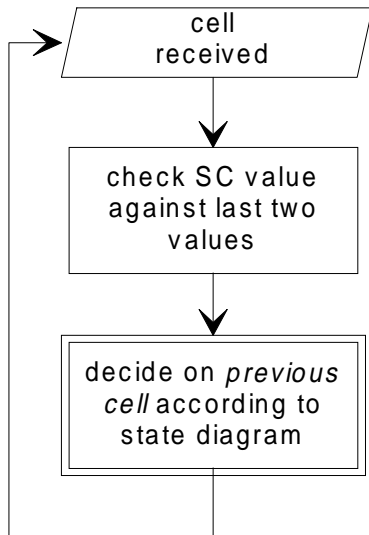

Fast SN Algorithm

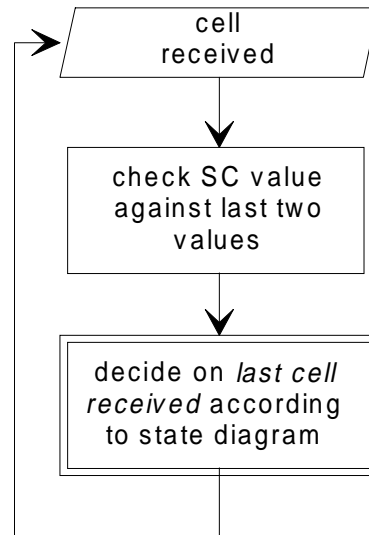

Figure E.1: Differences between robust and fast SN algorithm concerning the actions performed at the state machine

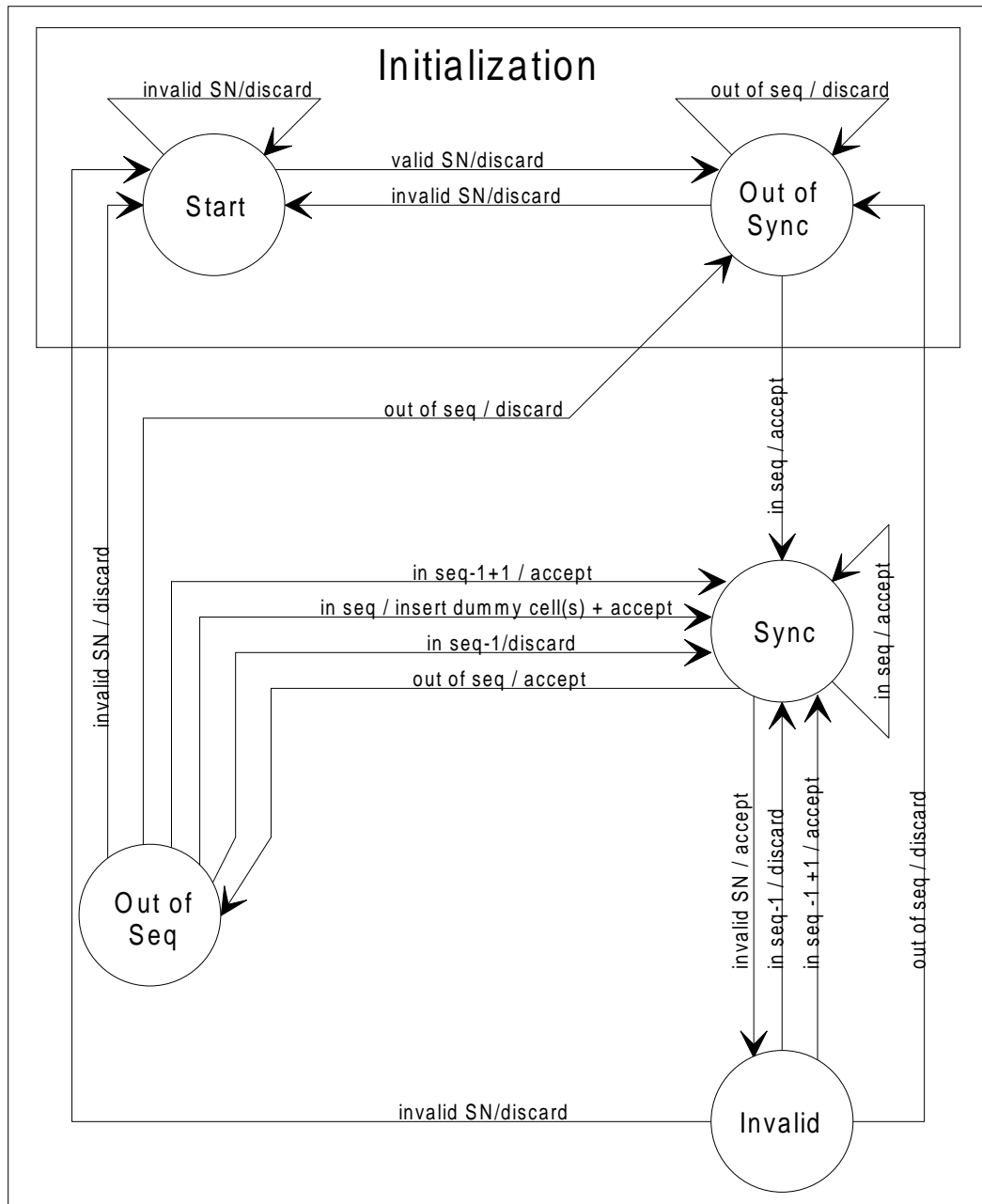

Figure E.2: Algorithm state machine

Annex F (normative): Protocol Implementation Conformance Statement (PICS) proforma for the AAL type 1

Notwithstanding the provisions of the copyright clause related to the text of this I-ETS, ETSI grants that users of this I-ETS may freely reproduce the PICS proforma in this annex so that it can be used for its intended purposes and may further publish the completed PICS.

F.1 Introduction

In the following, the PICS proforma for the AAL type 1 protocol as specified in the main body of this I-ETS is defined.

The first column in each table identifies the item. The second column describes the capability or parameter to be tested. The third column contains the reference to the subclause of this I-ETS in which the capability or parameter is defined. The fourth column indicates the status of the feature:

- m mandatory implementation;
- o optional implementation;
- c conditional;
- n/a not applicable.

The complete notation for conditional features is:

c: <x>

to indicate that, under certain conditions, the status for the feature becomes <x>, where <x> belongs to {m, o, n/a}.

For conditional features, the fifth column states the condition under which the feature can become mandatory, optional or not applicable.

The sixth column contains the possible values for the feature:

- xx .. yy indicates all the values from xx to yy;
- xx/yy indicates either xx or yy.

The last column indicates whether the feature is supported or not in a specific implementation.

F.2 PICS

F.2.1 SAR sublayer

F.2.1.1 Capabilities

Item	Capabilities	Reference	Status		Predicate	Support
			Transmission	Reception		
SAR 1	Mapping between CS-PDU and SAR-PDU	4.6.1.a	m	m		
SAR 2	Indication of existence of CS function	4.6.1.b	m	m		
SAR 3	Sequence numbering	4.6.1.c	m	m		
SAR 4	Error protection	4.6.1.d/ 4.6.2.2.a	m	n/a		
SAR 5	Error detection	4.6.1.d/ 4.6.2.2.b	n/a	m		
SAR 6	Error correction	4.6.1.d/ 4.6.2.2.b	n/a	m		
SAR 7	SN Check Status indication	4.6.1.d/ 4.6.2.2.b	n/a	m		

F.2.1.2 PDUs and PDU parameters

Item	Parameter	Reference	Status		Predicate	Value	Support
			Transmission	Reception			
SAR 8	SAR-PDU structure	4.6.2	m	m			
SAR 9	CSI bit	4.6.2.1	m	m		0/1	
SAR 10	Sequence count field	4.6.2.1	m	m		0..7	
SAR 11	SNP field	4.6.2.2	m	m			
SAR 12	SAR PDU payload content	4.6.2	m	m		any value	

F.2.2 CS major capabilities

Item	Major capability	Reference	Status	Support
CS 1	CS for circuit transport	4.7.1.1	o.1	
CS 2	CS for video signal transport	4.7.1.2	o.1	
CS 3	CS for voice band signal transport	4.7.1.3	o.1	
o.1 At least one of these capabilities shall be implemented.				

F.2.2.1 CS for circuit transport

F.2.2.1.1 Capabilities

Item	Capability	Reference	Status		Predicate	Support
			Transmission	Reception		
CS.CT.1	Structured data transfer	4.7.1.1.a	o	o		
CS.CT.2	SDT method	4.7.1.1.a/ 4.7.2.3	c: m c: n/a	c: m c: n/a	Structured data transfer else	
CS.CT.3	Maintain bit count integrity	4.7.1.1.b, 4.7.1.1.c	n/a	m		
CS.CT.4	Detection of lost and misinserted cells	4.7.1.1.c	n/a	m		
CS.CT.5	Discard of detected misinserted cells	4.7.1.1.c	n/a	m		
CS.CT.6	Sequence count operations at transmission	4.7.2.1.1	m	n/a		
CS.CT.7	Sequence count operations at reception	4.7.2.1.2	n/a	m		
CS.CT.8	SRTS method	4.7.2.2.2	c: m c: o c: n/a	c: m c: o c: n/a	common clock and asynchronous ITU-T Recommendation G.702 [1] signals common clock and other signal types no common clock	
CS.CT.9	Adaptive clock method	4.7.2.2.1	c: n/a	c: o		
CS.CT.10	Combination of SRTS and Adaptive clock method	4.7.2.2.3	c: o	c: o		
CS.CT.11	Use of CSI bit	4.7.2.3 4.7.2.2.2.4	c: m c: m c: n/a	c: m c: m c: n/a	SDT method SRTS method else	

F.2.2.1.2 Protocol parameters

Item	Parameter	Reference	Status		Predicate	Value	Support
			Transmission	Reception			
CS.CT.12	Length of AAL-SDU	4.7.1.1.a	c: m	c: m	SRTS method	1 bit	
			c: m	c: m	SDT without SRTS	1 octet	
			c: m	c: m	SDT with SRTS	1 bit	
			c: m	c: m	else	1 bit	
CS.CT.13	Value of inserted dummy bits	4.7.1.1.b	n/a	m		All 1's	
CS.CT.14	Service bit rate	4.7.1.1	o.3	o.3		ITU-T Recommendation G.702 [1] bit rates (e.g. 2 048 kbit/s, 8 448 kbit/s, 34 368 kbit/s) n x 64 kbit/s (n [1..32]) other bit rates	
CS.CT.15	Network clock frequency (fn)	4.7.2.2.2.3	c: m	c: m	SRTS method (SDH.SDH or PDH.SDH environment)	155,52 MHz	
			c: o	c: o	SRTS method and PDH.PDH environment	existing network clock (e.g. 2 048 MHz)	
			n/a	n/a	else		
CS.CT.16	Derived Network clock frequency (fnx)	4.7.2.2.2.3	c: o.2	c: o.2	SRTS method	$8\text{kHz} \cdot 19\,440 \cdot 2^{-k}$ $0 \leq k \leq 11$	
			c: n/a	c: n/a	else		
<p>o.2 The SRTS method shall be implemented to work at least with one of these values for the parameter fnx.</p> <p>o.3 Any non-empty subset of the values may be supported.</p>							

F.2.2.2 CS for video signal transport

F.2.2.2.1 Capabilities

Item	Capability	Reference	Status		Predicate	Support
			Transmission	Reception		
CS.VD.1	Structured data transfer	4.7.1.2.a	o	o		
CS.VD.2	SDT method	4.7.1.2.a/ 4.7.2.3	c: m c: n/a	c: m c: n/a	Structured data transfer else	
CS.VD.3	STATUS parameter indication	4.7.1.2.a	n/a	o		
CS.VD.4	Maintain bit count integrity	4.7.1.2.b/ 4.7.1.2.c	n/a	m		
CS.VD.5	Detection of lost and misinserted cells	4.7.1.2.c	n/a	m		
CS.VD.6	Discard of detected misinserted cells	4.7.1.2.c	n/a	m		
CS.VD.7	Sequence count operations at transmission	4.7.2.1.1	m	n/a		
CS.VD.8	Sequence count operations at reception	4.7.2.1.2	n/a	m		
CS.VD.9	correction method for bit errors	4.7.1.2.e/ 4.7.2.4.1	c: n/a c: m c: n/a	c: n/a c: m c:n/a	SDT method correction of bit errors for low bit rate conversational video else	
CS.VD.10	correction method for bit errors and cell losses with delay restrictions	4.7.1.2.e/ 4.7.2.4.3	c: n/a c: m c: n/a	c: n/a c: m c:n/a	SDT method correction of bit errors and cell losses for conversational video else	
CS.VD.11	correction method for bit errors and cell losses without delay restrictions	4.7.1.2.e/ 4.7.2.4.2	c: n/a c: m c: n/a	c: n/a c: m c:n/a	SDT method correction of bit errors and cell losses for unidirectional video else	
CS.VD.12	SRTS method	4.7.1.2.d	c: o c: n/a	c: o c: n/a	common clock no common clock	
CS.VD.13	Adaptive clock method	4.7.2.2.1	n/a	o		
CS.VD.14	Use of CSI bit	4.7.2.4 4.7.2.3 4.7.2.2.1	c: m c: m c: m c: n/a	c: m c: m c: m c: n/a	correction method SDT method SRTS method else	

F.2.2.2.2 Protocol parameters

Item	Parameter	Reference	Status		Predicate	Valut	Support
			Transmission	Reception			
CS.VD.15	Length of AAL-SDU	4.7.1.2.a	m	m		1 octet	
CS.VD.16	Network clock frequency (fn)	4.7.2.2.1.3/ 4.7.1.1 d)	c: m c: o c: n/a	c: m c: o c: n/a	SRTS method (SDH.SDH or PDH.SDH environment) SRTS method and PDH.PDH environment else	155,52 MHz existing network clock (e.g. 2 048 MHz)	
CS.VD.17	Derived Network clock frequency (fnx)	4.7.2.2.2.3	c: o.4 c: n/a	c: o.4 c: n/a	SRTS method else	8 kHz* 19 440*2 ^{-k} 0≤k≤11	
CS.VD.17	Service bit rate		o	o		any value	
CS.VD.18	Value of inserted dummy octets	4.7.1.2.b/ 4.7.1.2.c	n/a	m		All 1's	
o.4 At least one video service bite rate shall be supported							

F.2.2.3 CS for voice band signal transport**F.2.2.3.1 Capabilities**

Item	Capability	Reference	Status		Predicate	Support
			Transmission	Reception		
CS.VO.1	Detection of lost cells without additional delay	4.7.1.3.c	n/a	m		
CS.VO.2	Maintain bit count integrity	4.7.1.3.b/ 4.7.1.3.c	n/a	m		
CS.VO.3	Adaptive clock method	4.7.1.3.d	n/a	o		
CS.VO.4	Sequence count operation at transmission	4.7.2.1.1	m	n/a		
CS.VO.5	Sequence count operation at reception	4.7.1.3 4.7.2.1.2	n/a	o		

F.2.2.3.2 Protocol parameters

Item	Parameter	Reference	Status		Predicate	Value	Support
			Transmission	Reception			
CS.VO.7	Length of AAL-SDU	4.7.1.3.a	m	m		1 octet	
CS.VO.8	Value of inserted dummy bits	4.7.1.3.c	n/a	m		All 1's	

History

Document history	
April 1995	First Edition
December 1996	Public Enquiry PE 120: 1996-12-16 to 1997-04-11
August 1998	Vote V 9840: 1998-08-04 to 1998-10-02
October 1998	Second Edition