



EUROPEAN
TELECOMMUNICATION
STANDARD

ETS 300 347-5

February 1996

Source: ETSI TC-SPS

Reference: DE/SPS-03003.4-2

ICS: 33.020, 33.080, 35.100.30

Key words: V interface, V5 interface, PSTN, ISDN, LE, TSS&TP, testing, layer 3

**Signalling Protocols and Switching (SPS);
V interfaces at the digital Local Exchange (LE);
V5.2 interface for the support of Access Network (AN);
Part 5: Test Suite Structure and Test Purposes (TSS&TP)
specification for the network layer (LE side)**

ETSI

European Telecommunications Standards Institute

ETSI Secretariat

Postal address: F-06921 Sophia Antipolis CEDEX - FRANCE

Office address: 650 Route des Lucioles - Sophia Antipolis - Valbonne - FRANCE

X.400: c=fr, a=atlas, p=etsi, s=secretariat - **Internet:** secretariat@etsi.fr

Tel.: +33 92 94 42 00 - Fax: +33 93 65 47 16

*

Copyright Notification: No part may be reproduced except as authorized by written permission. The copyright and the foregoing restriction extend to reproduction in all media.

© European Telecommunications Standards Institute 1996. All rights reserved.

Contents

| | |
|---|----|
| Foreword | 7 |
| 1 Scope | 9 |
| 2 Normative references | 9 |
| 3 Definitions and abbreviations | 10 |
| 3.1 Definitions | 10 |
| 3.2 Abbreviations | 10 |
| 4 Test Suite Structure (TSS) | 11 |
| 4.1 Overview | 11 |
| 4.2 Test groups | 12 |
| 4.2.1 Protocol groups | 13 |
| 4.2.1.1 Control protocol | 13 |
| 4.2.1.2 Public Switched Telephone Network (PSTN) protocol | 13 |
| 4.2.1.3 Link control protocol | 13 |
| 4.2.1.4 Bearer Channel Connection (BCC) protocol | 13 |
| 4.2.1.5 Protection protocol | 13 |
| 4.2.2 Main test groups | 14 |
| 4.2.2.1 Basic interconnection tests (IT) | 14 |
| 4.2.2.2 Capability tests (CA) | 14 |
| 4.2.2.3 Valid behaviour tests (BV) | 14 |
| 4.2.2.4 Inopportune behaviour tests (BO) | 14 |
| 4.2.2.5 Invalid behaviour tests (BI) | 14 |
| 4.2.2.6 Timer expiry and counter mismatch tests (TI) | 14 |
| 4.2.2.6.1 Timers and counters of the Control protocol | 14 |
| 4.2.2.6.2 Timers and counters of the PSTN protocol | 14 |
| 4.2.2.6.3 Timers and counters of the Link control protocol | 14 |
| 4.2.2.6.4 Timers and counters of the BCC protocol | 14 |
| 4.2.2.6.5 Timers and counters of the Protection protocol | 14 |
| 4.2.2.6.6 Timers and counters of the LE system management | 15 |
| 4.3 Test step structure | 15 |
| 4.3.1 State transitions | 15 |
| 4.3.1.1 Start-up of V5.2 interface | 15 |
| 4.3.1.2 Common control protocol (system management) | 17 |
| 4.3.1.3 Control protocol (PSTN port FSM) | 17 |
| 4.3.1.4 Control protocol (ISDN-BA port FSM) | 17 |
| 4.3.1.5 Control protocol (ISDN-PRA port FSM) | 17 |
| 4.3.1.6 PSTN protocol | 18 |
| 4.3.1.7 Link control protocol | 18 |
| 4.3.1.8 BCC protocol | 18 |
| 4.3.1.9 Protection protocol | 19 |
| 4.3.2 Preambles | 19 |
| 4.3.3 Postambles | 19 |
| 4.3.4 Status verification | 20 |
| 4.3.4.1 PSTN protocol | 20 |
| 4.3.4.2 Link control FSM | 20 |
| 4.3.5 Common test steps | 20 |
| 4.4 Defaults | 20 |
| 4.5 Abstract Service Primitives (ASPs) and Protocol Data Units (PDUs) | 20 |
| 4.5.1 ASPs | 20 |
| 4.5.2 PDUs | 21 |
| 4.5.2.1 Common control protocol | 21 |
| 4.5.2.2 Port control protocol | 21 |
| 4.5.2.3 PSTN protocol | 21 |
| 4.5.2.4 Link control protocol | 21 |

| | | | |
|-------|-----------|--|----|
| | 4.5.2.5 | BCC protocol..... | 21 |
| | 4.5.2.6 | Protection protocol..... | 21 |
| 4.5.3 | | Information elements..... | 21 |
| | 4.5.3.1 | Variable length information elements..... | 21 |
| | 4.5.3.1.1 | Control protocol..... | 21 |
| | 4.5.3.1.2 | PSTN protocol..... | 21 |
| | 4.5.3.1.3 | Link control protocol..... | 21 |
| | 4.5.3.1.4 | BCC protocol..... | 22 |
| | 4.5.3.1.5 | Protection protocol..... | 22 |
| | 4.5.3.2 | Single octet information elements..... | 22 |
| | 4.5.3.2.1 | Control protocol..... | 22 |
| | 4.5.3.2.2 | PSTN protocol..... | 22 |
| | 4.5.3.2.3 | Link control protocol..... | 22 |
| | 4.5.3.2.4 | BCC protocol..... | 22 |
| | 4.5.3.2.5 | Protection protocol..... | 22 |
| 4.6 | | Timers and counters of the Abstract Test Suite (ATS)..... | 22 |
| 5 | | Test Purposes (TPs)..... | 24 |
| 5.1 | | Introduction..... | 24 |
| | 5.1.1 | Test purpose naming convention..... | 24 |
| | 5.1.2 | Source of test purpose definition..... | 25 |
| | 5.1.3 | Test strategy..... | 25 |
| | 5.1.3.1 | Common control protocol..... | 25 |
| | 5.1.3.2 | Port control protocol..... | 25 |
| | 5.1.3.3 | PSTN protocol..... | 25 |
| | 5.1.3.4 | Link control protocol..... | 26 |
| | 5.1.3.5 | BCC protocol..... | 26 |
| | 5.1.3.6 | Protection protocol..... | 27 |
| | 5.1.4 | Requirements not covered by test purposes..... | 27 |
| | 5.1.5 | Initial states..... | 27 |
| | 5.1.6 | Test and data configuration requirements..... | 28 |
| 5.2 | | Control protocol..... | 28 |
| | 5.2.1 | Basic interconnection tests (V5NWKLE/CTRL/IT)..... | 28 |
| | 5.2.2 | Capability tests (V5NWKLE/CTRL/CA)..... | 28 |
| | 5.2.3 | Valid behaviour tests (V5NWKLE/CTRL/BV)..... | 28 |
| | 5.2.3.1 | V5NWKLE/CTRL/BV/COM..... | 28 |
| | 5.2.3.2 | V5NWKLE/CTRL/BV/PORT..... | 29 |
| | 5.2.3.2.1 | V5NWKLE/CTRL/BV/PORT/TRANS..... | 29 |
| | 5.2.3.2.2 | V5NWKLE/CTRL/BV/PORT/PSTN..... | 29 |
| | 5.2.3.2.3 | V5NWKLE/CTRL/BV/PORT/ISDNBA..... | 29 |
| | 5.2.3.2.4 | V5NWKLE/CTRL/BV/PORT/ISDNPRA..... | 29 |
| | 5.2.4 | Inopportune behaviour tests (V5NWKLE/CTRL/BO)..... | 31 |
| | 5.2.4.1 | V5NWKLE/CTRL/BO/COM..... | 31 |
| | 5.2.4.2 | V5NWKLE/CTRL/BO/PORT..... | 31 |
| | 5.2.4.2.1 | V5NWKLE/CTRL/BO/PORT/TRANS..... | 31 |
| | 5.2.4.2.2 | V5NWKLE/CTRL/BO/PORT/ISDNBA..... | 31 |
| | 5.2.4.2.3 | V5NWKLE/CTRL/BO/PORT/ISDNPRA..... | 31 |
| | 5.2.5 | Invalid behaviour tests (V5NWKLE/CTRL/BI)..... | 32 |
| | 5.2.6 | Timer expiry and counter mismatch tests (V5NWKLE/CTRL/TI)..... | 32 |
| 5.3 | | PSTN protocol..... | 32 |
| 5.4 | | Link control protocol..... | 32 |
| | 5.4.1 | Basic interconnection tests (V5NWKLE/LINK/IT)..... | 32 |
| | 5.4.2 | Capability tests (V5NWKLE/LINK/CA)..... | 32 |
| | 5.4.3 | Valid behaviour tests (V5NWKLE/LINK/BV)..... | 32 |
| | 5.4.3.1 | V5NWKLE/LINK/BV/TRANS..... | 32 |
| | 5.4.3.2 | V5NWKLE/LINK/BV/LINK..... | 33 |
| | 5.4.4 | Inopportune behaviour tests (V5NWKLE/LINK/BO)..... | 45 |
| | 5.4.4.1 | V5NWKLE/LINK/BO/TRANS..... | 45 |
| | 5.4.4.2 | V5NWKLE/LINK/BO/LINK..... | 45 |
| | 5.4.5 | Invalid behaviour tests (V5NWKLE/LINK/BI)..... | 48 |
| | 5.4.5.1 | V5NWKLE/LINK/BI/TRANS..... | 48 |
| | 5.4.6 | Timer expiry and counter mismatch tests (V5NWKLE/LINK/TI)..... | 49 |
| | 5.4.6.1 | V5NWKLE/LINK/TI/TRANS..... | 49 |

| | | |
|------------------------|--|----|
| 5.5 | BCC protocol..... | 49 |
| 5.5.1 | Basic interconnection tests (V5NWKLE/BCC/IT) | 50 |
| 5.5.2 | Capability tests (V5NWKLE/BCC/CA)..... | 50 |
| 5.5.3 | Valid behaviour tests (V5NWKLE/BCC/BV)..... | 51 |
| 5.5.4 | Inopportune behaviour tests (V5NWKLE/BCC/BO) | 55 |
| 5.5.5 | Invalid behaviour tests (V5NWKLE/BCC/BI)..... | 57 |
| 5.5.6 | Timer expiry and counter mismatch tests (V5NWKLE/BCC/TI)..... | 59 |
| 5.6 | Protection protocol | 60 |
| 5.6.1 | Basic interconnection tests (V5NWKLE/PROTECT/IT) | 61 |
| 5.6.2 | Capability tests (V5NWKLE/PROTECT/CA) | 61 |
| 5.6.3 | Valid behaviour tests (V5NWKLE/PROTECT/BV) | 61 |
| 5.6.4 | Invalid behaviour tests (V5NWKLE/PROTECT/BI) | 66 |
| 5.6.5 | Timer expiry and counter mismatch tests (V5NWKLE/PROTECT/TI) | 66 |
| Annex A (informative): | Bibliography | 69 |
| History..... | | 70 |

Blank page

Foreword

This European Telecommunication Standard (ETS) has been produced by the Signalling Protocols and Switching (SPS) Technical Committee of the European Telecommunications Standards Institute (ETSI).

This ETS is part 5 of a multi-part standard covering the V5.2 interface as described below:

- Part 1: "V5.2 interface specification";
- Part 2: "Protocol Implementation Conformance Statement (PICS) proforma";
- Part 3: "Test Suite Structure and Test Purposes (TSS&TP) specification for the network layer (AN side)";
- Part 4: "Abstract Test Suite (ATS) and partial Protocol Implementation eXtra Information for Testing (PIXIT) proforma specification for the network layer (AN side)";
- Part 5: "TSS&TP specification for the network layer (LE side)";**
- Part 6: "ATS and partial PIXIT proforma specification for the network layer (LE side)";
- Part 7: "TSS&TP specification for the data link layer";
- Part 8: "ATS and partial PIXIT proforma specification for the data link layer";
- Part 9: "Test specification for the physical layer".

| Transposition dates | |
|---|------------------|
| Date of adoption of this ETS: | 1 March 1996 |
| Date of latest announcement of this ETS (doa): | 31 May 1996 |
| Date of latest publication of new National Standard or endorsement of this ETS (dop/e): | 30 November 1996 |
| Date of withdrawal of any conflicting National Standard (dow): | 30 November 1996 |

Blank page

1 Scope

This fifth part of ETS 300 347 contains the Test Suite Structure and Test Purposes (TSS&TP) for the network layer and parts of the system management of the Local Exchange (LE) side of a V5.2 interface.

The objective of this ETS is to provide conformance tests giving a high probability of inter-operability of an Access Network (AN) and a LE from different manufacturers over the V5.2 interface. This ETS covers only the procedures described in ETS 300 347-1 [2].

ISO/IEC 9646-1 [4] and ISO/IEC 9646-2 [5] are used as the basis for the test methodology.

This ETS needs to be read in conjunction with ETS 300 324-5 [1]. The two documents share a common format and clauses within ETS 300 324-5 [1] are directly referenced.

Annex A lists the bibliography.

2 Normative references

This ETS incorporates by dated and undated reference, provisions from other publications. These normative references are cited at the appropriate places in the text and the publications are listed hereafter. For dated references, subsequent amendments to or revisions of any of these publications apply to this ETS only when incorporated in it by amendment or revision. For undated references the latest edition of the publication referred to applies.

- [1] ETS 300 324-5 (1995): "Signalling Protocols and Switching (SPS); V interfaces at the digital Local Exchange (LE); V5.1 interface for the support of Access Network (AN); Part 5: Test Suite Structure and Test Purposes (TSS&TP) specification for the network layer (LE side)".
- [2] ETS 300 347-1 (1994): "Signalling Protocols and Switching (SPS); V interfaces at the digital Local Exchange (LE); V5.2 interface for the support of Access Network (AN); Part 1: V5.2 interface specification".
- [3] ETS 300 347-2 (1994): "Signalling Protocols and Switching (SPS); V interfaces at the digital Local Exchange (LE); V5.2 interface for the support of Access Network (AN); Part 2: Protocol Implementation Conformance Statement (PICS) proforma".
- [4] ISO/IEC 9646-1 (1995): "Information technology - Open systems interconnection - Conformance testing methodology and framework - Part 1: General concepts".
- [5] ISO/IEC 9646-2 (1995): "Information technology - Open systems interconnection - Conformance testing methodology and framework - Part 2: Abstract test suite specification".

3 Definitions and abbreviations

3.1 Definitions

For the purposes of this ETS, the following definitions apply, in addition to those given in ETS 300 324-5 [1] and ETS 300 347-1 [2]:

specified information element: Information element identifier as defined in ETS 300 347-1 [2].

unspecified information element: Information element identifier which is not defined in ETS 300 347-1 [2].

incorrect information element: A specified information element carrying information element types which are not defined in ETS 300 347-1 [2].

3.2 Abbreviations

For the purposes of this ETS, the following abbreviations apply:

| | |
|----------|--|
| AIS | Alarm Indication Signal |
| AN | Access Network |
| ASP | Abstract Service Primitive |
| ATS | Abstract Test Suite |
| BCC | Bearer Channel Connection |
| BI | Invalid Behaviour |
| BO | Inopportune Behaviour |
| BV | Valid Behaviour |
| CA | Capability |
| COM | Common control protocol |
| CTRL | Control |
| FE | Function Element |
| FSM | Finite State Machine |
| ID | Identifier |
| IE | Information Element |
| ISDN | Integrated Services Digital Network |
| ISDN-BA | ISDN Basic Access |
| ISDN-PRA | ISDN Primary Rate Access |
| IT | Basic Interconnection |
| IUT | Implementation Under Test |
| L3addr | Layer 3 address |
| LE | Local Exchange |
| LT1 | Lower Tester 1 |
| MDU | Management Data Unit |
| MPH | Management Physical layer |
| NWK | Network layer |
| PDU | Protocol Data Unit |
| PICS | Protocol Implementation Conformance Statements |
| PSTN | Public Switched Telephone Network |
| RAI | Remote Alarm Indication |
| REQ | Request |
| SN | Sequence Number |
| SUT | System Under Test |
| TE | Terminal Equipment (ISDN or PSTN) |
| TI | Timer |
| TP | Test Purpose |
| TS | Time Slot |
| TSS | Test Suite Structure |
| UP | User Port |

4 Test Suite Structure (TSS)

4.1 Overview

Figure 1 shows the structure of the V5.2 network layer test suite.

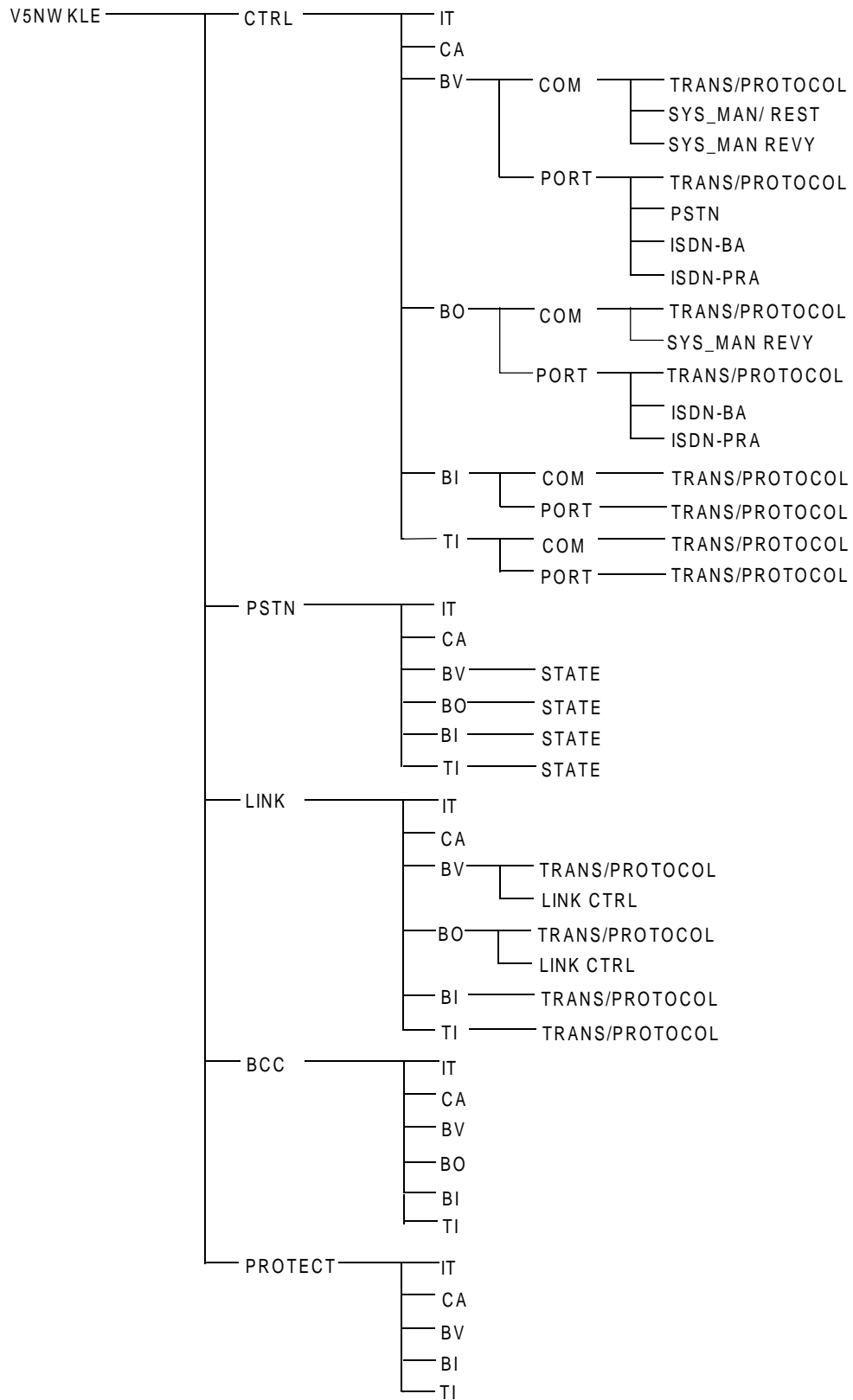

Figure 1: Network Layer LE test suite structure

4.2 Test groups

Figure 2 gives an overview of the various protocol entities of a V5.2 interface. Table 1 maps each protocol entity on tested protocol groups.

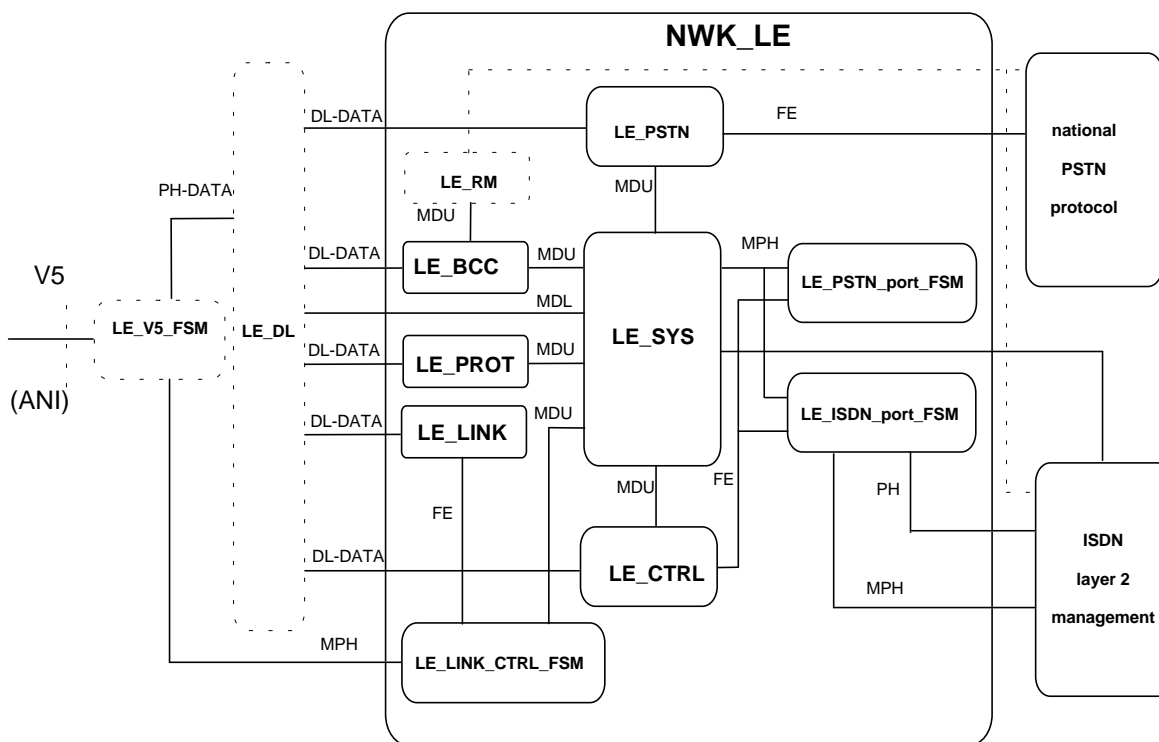

Figure 2: Network layer LE - protocol entity overview

Table 1: Names used in figure 2 that correspond to ETS 300 347-1 [2]

| Network layer protocol entities | Protocol entities defined in ETS 300 347-1 [2] | Protocol group references |
|---------------------------------|---|---------------------------|
| LE_PSTN_port_FSM | LE_PSTN_user_port_FSM | 4.2.1.1 |
| LE_ISDN_port_FSM | LE_ISDN-BA_user_port_FSM LE_ISDN-PRA_user_port_FSM | 4.2.1.1 |
| LE_CTRL | LE_control_protocol | 4.2.1.1 |
| LE_SYS | LE_system_management | 4.2.1.1 |
| LE_PSTN | LE_PSTN_protocol | 4.2.1.2 |
| LE_LINK | LE_link_control_protocol | 4.2.1.3 |
| LE_LINK_CTRL_FSM | LE_link_control_FSM | 4.2.1.3 |
| LE_RM | LE_resource_management | 4.2.1.4 |
| LE_BCC | LE_BCC_protocol | 4.2.1.4 |
| LE_PROT | LE_protection_protocol | 4.2.1.5 |

4.2.1 Protocol groups

4.2.1.1 Control protocol

The contents of this subclause are identical to subclause 4.2.1.1 of ETS 300 324-5 [1] with the following additions for the ISDN-PRA user port Finite State Machine (FSM).

Depending on provisioning the following configuration is tested:

LE_ISDN-PRA_user_port: The blocking, blocking request and co-ordinated unblocking procedures of the LE_ISDN-PRA_user_port_FSM are verified in the test groups V5NWKLE/CTRL/BV/PORT/ISDNPRA and V5NWKLE/CTRL/BO/PORT/ISDNPRA.

4.2.1.2 Public Switched Telephone Network (PSTN) protocol

The contents of this subclause are identical to subclause 4.2.1.2 of ETS 300 324-5 [1].

4.2.1.3 Link control protocol

All tests in the Link control protocol (V5NWKLE/LINK) test group are intended to verify as thoroughly as possible the various procedures of the LE_link_control_protocol entity. Depending on provisioning the following configurations are covered:

LE_link_control_protocol: The normal and exceptional procedures of the LE_link_control_protocol are verified in the test groups V5NWKLE/LINK/BV/TRANS, V5NWKLE/LINK/BO/TRANS and V5NWKLE/LINK/TI/TRANS.

The error handling procedures are verified in the test group V5NWKLE/LINK/BI/TRANS.

LE_link_control_FSM: The link failure, link blocking, link blocking request, co-ordinated link unblocking and link identification procedures of the LE_link_control_FSM are verified in the test group V5NWKLE/LINK/BV/LINK and V5NWKLE/LINK/BO/LINK.

4.2.1.4 Bearer Channel Connection (BCC) protocol

All tests in the BCC protocol (V5NWKLE/BCC) test group are intended to verify as thoroughly as possible the various procedures of the LE_BCC protocol entity.

The following BCC procedures are covered:

- normal and exceptional bearer channel allocation procedure;
- normal and exceptional bearer channel de-allocation procedure;
- audit procedure;
- AN internal failure notification procedure;
- error handling procedures.

4.2.1.5 Protection protocol

All tests in the Protection protocol (V5NWKLE/PROTECT) test group are intended to verify as thoroughly as possible the various procedures of the LE Protection protocol entity.

The following Protection protocol procedures are covered:

- transmission of Protection protocol messages;
- normal and exceptional sequence number reset procedure;
- normal and exceptional standard protection switch-over procedure initiated by LE side;
- normal and exceptional dedicated protection switch-over procedure initiated by OS LE;
- normal and exceptional switch-over procedure requested by AN side;
- error handling procedures.

4.2.2 Main test groups

4.2.2.1 Basic interconnection tests (IT)

The contents of this subclause are identical to subclause 4.2.2.1 of ETS 300 324-5 [1].

4.2.2.2 Capability tests (CA)

The contents of this subclause are identical to subclause 4.2.2.2 of ETS 300 324-5 [1].

4.2.2.3 Valid behaviour tests (BV)

The contents of this subclause are identical to subclause 4.2.2.3 of ETS 300 324-5 [1].

4.2.2.4 Inopportune behaviour tests (BO)

The contents of this subclause are identical to subclause 4.2.2.4 of ETS 300 324-5 [1].

4.2.2.5 Invalid behaviour tests (BI)

The contents of this subclause are identical to subclause 4.2.2.5 of ETS 300 324-5 [1].

4.2.2.6 Timer expiry and counter mismatch tests (TI)

Different timers and counters are defined to supervise the various state transitions. This test group is intended to verify that the FSM is reacting properly to an expire of one of the timers or counter mismatch.

4.2.2.6.1 Timers and counters of the Control protocol

The contents of this subclause are identical to subclause 4.2.2.6.1 of ETS 300 324-5 [1].

4.2.2.6.2 Timers and counters of the PSTN protocol

The contents of this subclause are identical to subclause 4.2.2.6.2 of ETS 300 324-5 [1].

4.2.2.6.3 Timers and counters of the Link control protocol

Refer to the ETS 300 347-1 [2], table 23.

LCTO1 LINK CONTROL message sent

4.2.2.6.4 Timers and counters of the BCC protocol

Refer to the ETS 300 347-1 [2], table 46.

TBCC1 ALLOCATION sent
TBCC2 DE-ALLOCATION sent
TBCC3 DE-ALLOCATION sent
TBCC4 AUDIT sent

4.2.2.6.5 Timers and counters of the Protection protocol

Refer to the ETS 300 347-1 [2], table 64.

TSO1 SWITCH-OVER COM sent
TSO2 OS-SWITCH-OVER COM sent
TSO4 RESET SN COM sent
TSO5 RESET SN COM received

Refer to the ETS 300 347-1 [2], subclause 18.6.2.

VP(S) Send State Variable
VP(R) Receive State Variable

4.2.2.6.6 Timers and counters of the LE system management

The contents of this subclause are identical to subclause 4.2.6.3 of ETS 300 324-5 [1].

4.3 Test step structure

General dynamic behaviours are described in test steps which can be called from all test cases within the Abstract Test Suite (ATS):

state transitions (refer to subclause 4.3.1);
preambles (refer to subclause 4.3.2);
postambles (refer to subclause 4.3.3);
status verification (refer to subclause 4.3.4);
common test steps (refer to subclause 4.3.5).

4.3.1 State transitions

The following subclauses identify the test steps used in the ATS. In general, each test step represents a state transition. For example in the PSTN protocol, PSTN_LE1_2 is the test step which brings the LE PSTN protocol FSM from PSTN_path_state LE1 to PSTN_path_state LE2. The state transitions are declared in the parenthesis (originating state - destination state) which follow the test step names.

Six groups of state transitions are defined:

STARTUP start up the V5 interface and put the IUT into the initial state as defined in subclause 5.1.5.

CTRL state transitions used to preamble and postamble the Control protocol before a test purpose can be performed.

PSTN state transitions used to preamble and postamble the PSTN protocol before a test purpose can be performed.

LINK state transitions used to preamble and postamble the Link control protocol before a test purpose can be performed.

BCC state transitions used to preamble and postamble the BCC protocol before a test purpose can be performed.

PROTECT state transitions used to preamble and postamble the Protection protocol before a test purpose can be performed.

To test the V5.2 interface certain sequences (i.e. preamble) shall be executed to reach the state which is the subject for the test purposes.

4.3.1.1 Start-up of V5.2 interface

The start-up procedure for a V5.2 interface depends on the provisioned data configuration. Therefore, the three PICS items N11, N12 and N2 (see subclause 6.5.1 of ETS 300 347-2 [3]) are used to define the implemented configuration of the IUT.

NOTE 1: ETS 300 347-2 [3] requires that at least one of the three PICS items shall be set.

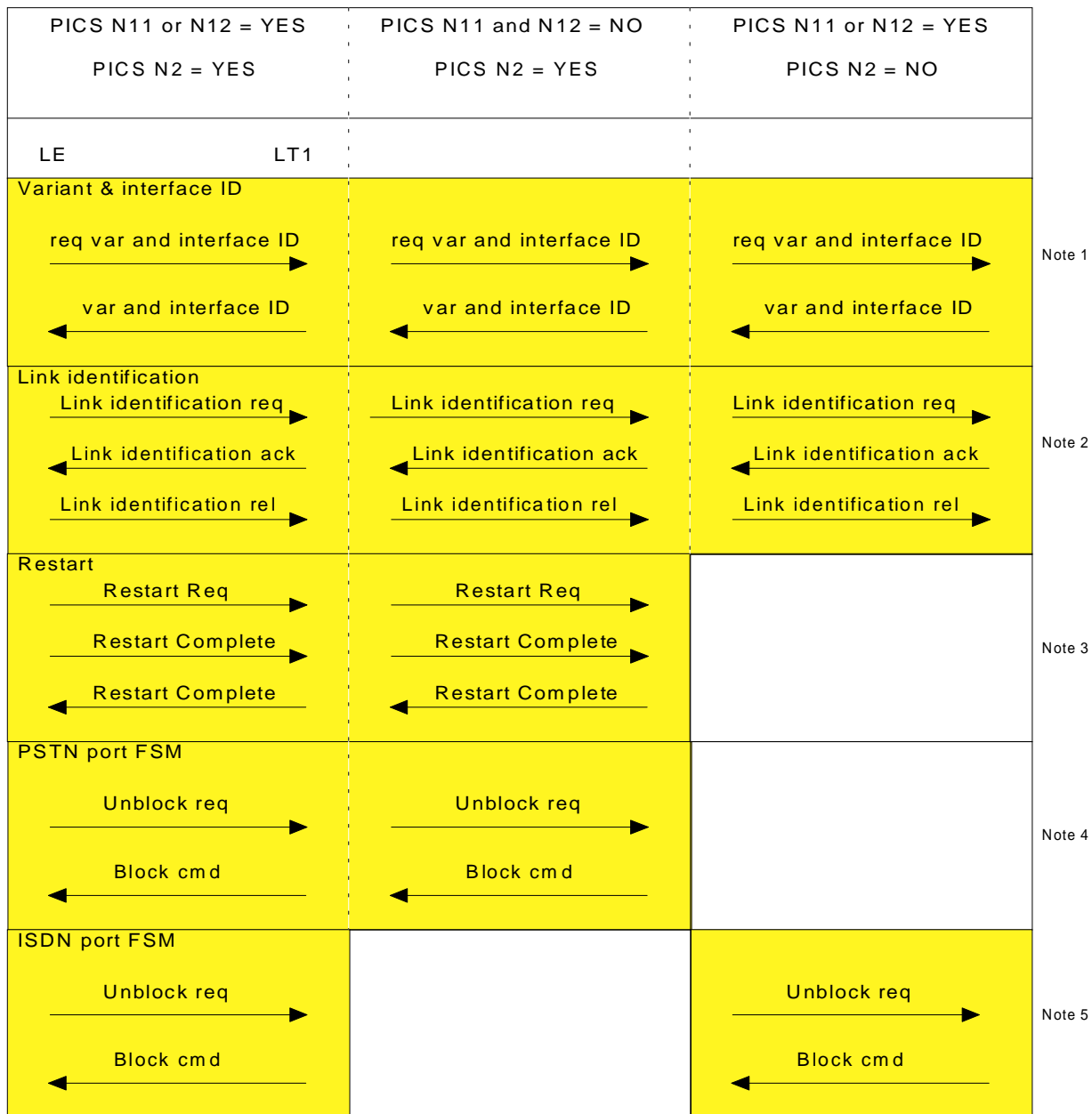

- NOTE 1: A test of the IUT's capability of receiving a request for the variant and interface ID is covered in subclause 5.2.3.1.
- NOTE 2: The number of appearances of this part of the system start-up procedure depends on the configuration of the IUT. A test of the IUT's capability of receiving a link identification request is covered in subclause 5.4.3.2.
- NOTE 3: LT1 shall wait for the receipt of restart complete from the IUT before sending restart complete.
- NOTE 4: To reach the initial state of the IUT PSTN user port FSM as defined in subclause 5.1.5, the IUT's unblocking request is rejected by LT1. Before rejecting the unblock request, it shall be verified that the IUT PSTN protocol has entered the PSTN_path_state AN6 (Port Blocked).
- NOTE 5: If the PICS items N11 and N12 are set to YES, this part of the system start-up procedure appears twice, once for the ISDN-BA port and once for the ISDN-PRA port. To reach the initial state of the IUT ISDN-BA user port FSM and/or the ISDN-PRA user port FSM as defined in subclause 5.1.5, the IUT's unblocking request is rejected by LT1.

Figure 3: STARTUP_LE flow diagram

PICS item description:

N11: ISDN-BA ports supported;
N12: ISDN-PRA ports supported;
N2: PSTN ports supported.

NOTE 2: One port of each supported type shall be provisioned in a way that the IUT tries to enter the operational state for these ports after system startup (refer to subclause 5.1.6).

Depending on the setting of the PICS items, the start-up procedure is described in figure 3. This flow diagram describes the test step called STARTUP_LE.

4.3.1.2 Common control protocol (system management)

The contents of this subclause are identical to subclause 4.3.1.2 of ETS 300 324-5 [1].

4.3.1.3 Control protocol (PSTN port FSM)

The contents of this subclause are identical to subclause 4.3.1.3 of ETS 300 324-5 [1] with the following replacements:

CTRL_PSTN_LE20_10

On receipt of a PORT CONTROL message containing the control_function_element IE FE204 (block_cmd) the IUT PSTN user port FSM shall enter state LE1.0.

If there is any V5.2 time slot allocated to the affected port, the IUT shall send a DE-ALLOCATION message. In that case this test step is completed by sending a DE-ALLOCATION COMPLETE message.

NOTE: This results in a state transition of the PSTN protocol as well. The PSTN protocol of the affected port is forced to enter the PSTN_path_state LE6.

4.3.1.4 Control protocol (ISDN-BA port FSM)

The contents of this subclause are identical to subclause 4.3.1.4 of ETS 300 324-5 [1] with the following replacements:

CTRL_ISDNBA_LE20_10

On receipt of a PORT CONTROL message containing the control_function_element IE FE204 (block_cmd) the IUT ISDN-BA user port FSM shall enter state LE1.0.

If there is any V5.2 time slot allocated to the affected port, the IUT shall send a DE-ALLOCATION message. In that case this test step is completed by sending a DE-ALLOCATION COMPLETE message.

4.3.1.5 Control protocol (ISDN-PRA port FSM)

Refer to the ETS 300 347-1 [2], table 8.

CTRL_ISDNPRA_LE20_10

On receipt of a PORT CONTROL message containing the control_function_element IE FE204 (block_cmd) the IUT ISDN-PRA port FSM shall enter state LE1.0.

Complete this test step by sending a PORT CONTROL message containing the control_function_element IE FE209 (TE_out_of_service).

If there is any V5.2 time slot allocated to the affected port, the IUT shall send a DE-ALLOCATION message. In that case this test step is completed by sending a DE-ALLOCATION COMPLETE message.

CTRL_ISDNPRA_LE10_20

On receipt of a PORT CONTROL message containing the control_function_element IE FE202 (unlock req) the IUT shall respond with the PORT CONTROL message containing the control_function_element IE FE201 (unlock_ack) and the IUT ISDN-PRA port FSM shall then enter state LE2.0.

4.3.1.6 PSTN protocol

The contents of this subclause are identical to subclause 4.3.1.5 of ETS 300 324-5 [1] with the following replacements:

PSTN_LEx_6

On receipt of a PORT CONTROL message containing the control_function_element IE FE204 (block cmd) the IUT PSTN protocol shall enter PSTN_path_state LE6.

If there is any V5.2 time slot allocated to the affected port, the IUT shall send a DE-ALLOCATION message. In that case this test step is completed by sending a DE-ALLOCATION COMPLETE message.

PSTN_LE1_2

On receipt of a terminating call request (FE-establish_request) the IUT protocol shall send an ALLOCATION message.

On receipt of a DE-ALLOCATION message the IUT shall send an ESTABLISH message and enter PSTN_path_state LE2.

PSTN_LE4_5

On receipt of a SIGNAL message containing a faulty sequence number the IUT PSTN protocol shall send a DISCONNECT message and enter PSTN_path_state LE5.

If there is any V5.2 time slot allocated to the affected port, the IUT shall send a DE-ALLOCATION message. In that case this test step is completed by sending a DE-ALLOCATION COMPLETE message.

PSTN_LE1_3_4

On receipt of an ESTABLISH message the IUT shall send an ESTABLISH ACK and an ALLOCATION message and the IUT PSTN protocol shall enter PSTN_path_state LE4.

Complete this step by sending an ALLOCATION COMPLETE message.

4.3.1.7 Link control protocol

LINK_LE20_10

On receipt of a LINK CONTROL message containing the link_control_function IE FE304 (link_block_cmd) the IUT link control FSM shall enter state LE1.0.

NOTE: The blocking of a V5.2 link results in a protection switching (if possible) of all C-paths carried by that link.

LINK_LE10_20

On receipt of a LINK CONTROL message containing the link_control_function IE FE302 (link_unblock_req) the IUT shall respond with the LINK CONTROL message containing the link_control_function IE FE301 (link_unblock_ack) and then enter state LE2.0.

4.3.1.8 BCC protocol

BCC_ALLOC

On receipt of an originating call attempt, the IUT shall send an ALLOCATION message containing the originating UP referenced in the UP_ID IE.

BCC_CONN

On receipt of an originating call attempt, the IUT shall send an ALLOCATION message containing the originating UP referenced in the UP_ID IE.

Complete the test step by sending an ALLOCATION COMPLETE message.

BCC_DEALLOC

On receipt of an originating call attempt, the IUT shall send an ALLOCATION message containing the originating UP referenced in the UP_ID IE.

On receipt of an ALLOCATION COMPLETE message, the IUT shall respond to the originating call attempt.

On receipt of a user release request, the IUT shall send a DE-ALLOCATION message containing the originating UP referenced in the IE UP_ID IE and the allocated V5 TS referenced in the V5_TS_ID IE.

BCC_AUDIT

On receipt of an originating call attempt, the IUT shall send an ALLOCATION message containing the originating UP referenced in the UP_ID IE.

On receipt of an ALLOCATION REJECT message containing the reject_cause IE "connection already present at the UP to a different V5 TS", the IUT shall send an AUDIT message containing only the UP_ID IE.

4.3.1.9 Protection protocol

PROTECT_SOLEX_0

On receipt of a RESET SN COM message, the IUT shall send a RESET SN ACK message (IUT protection FSM enters state SOLE0).

Complete this teststep by waiting for the expiration of timer TSO5.

PROTECT_BACK_TO_INIT1

On receipt of a SWITCH-OVER REQ message containing the logical_C-channel_ID IE "logical C-channel 1" and the physical_C-channel_ID IE "TS 16 of primary link", the IUT shall send a SWITCH-OVER COM message containing the same data.

Complete the teststep by sending a SWITCH-OVER ACK message containing the same data.

PROTECT_BACK_TO_INIT2

On receipt of a SWITCH-OVER REQ message containing the logical_C-channel_ID IE "logical C-channel 2" and the physical_C-channel_ID IE "TS 15 of primary link", the IUT shall send a SWITCH-OVER COM message containing the same data.

Complete the teststep by sending a SWITCH-OVER ACK message containing the same data.

PROTECT_BACK_TO_INIT3

On receipt of a SWITCH-OVER REQ message containing the logical_C-channel_ID IE "logical C-channel 3" and the physical_C-channel_ID IE "TS 31 of primary link", the IUT shall send a SWITCH-OVER COM message containing the same data.

Complete the teststep by sending a SWITCH-OVER ACK message containing the same data.

4.3.2 Preambles

The preamble test group contains the preamble test steps needed for initialization of the IUT before testing the particular test purpose. All combinations of the test steps defined in subclauses 4.3.1.2 to 4.3.1.9 can be used to create preambles. Each preamble shall start from the IUT initial state as defined in subclause 5.1.5.

4.3.3 Postambles

After each test case the IUT shall be brought back to the initial state as defined in subclause 5.1.5. All combinations of the test steps defined in subclauses 4.3.1.2 to 4.3.1.9 can be used to create postambles.

4.3.4 Status verification

4.3.4.1 PSTN protocol

The contents of this subclause are identical to subclause 4.3.4 of ETS 300 324-5 [1] with the following replacements:

PSTN_CHECK_STATE_2 (Path initiated by LE)

On receipt of a SIGNAL message the IUT PSTN protocol shall send a STATUS ENQUIRY message ⇒ the IUT PSTN protocol is not in one of the PSTN_path_states LE4 and LE5.

On receipt of a STATUS message containing the cause_type "response to status enquiry" and the state IE "AN1" the IUT PSTN protocol shall not send a DISCONNECT message ⇒ the IUT PSTN protocol is not in the PSTN_path_state LE3.

On receipt of a SIGNAL message, the IUT PSTN protocol shall send again a STATUS ENQUIRY message.

On receipt of a STATUS message containing the cause_type "response to status enquiry" and the state IE "AN3" the IUT shall send a DISCONNECT and a DE-ALLOCATION message ⇒ the IUT PSTN protocol is not in one of the PSTN_path_states LE0, LE1 and LE6.

Complete this test step by sending a DISCONNECT COMPLETE and a DE-ALLOCATION COMPLETE message (IUT PSTN protocol enters the PSTN_path_state LE1).

PSTN_CHECK_STATE_4 (Path active)

On receipt of an ESTABLISH message the IUT PSTN protocol shall send a STATUS ENQUIRY message ⇒ the IUT PSTN protocol is not in one of the PSTN_path_states LE1, LE2, LE3 and LE5.

On receipt of a STATUS message containing the cause_type "response to status enquiry" and the state IE "AN2" the IUT shall send a DISCONNECT and a DE-ALLOCATION message ⇒ the IUT PSTN protocol is not in one of the PSTN_path_states LE0 and LE6.

Complete this test step by sending a DISCONNECT COMPLETE and a DE-ALLOCATION COMPLETE message (IUT PSTN protocol enters the PSTN_path_state LE1).

4.3.4.2 Link control FSM

LINK_CHECK_ID

On receipt of a message containing the link_control_function IE FE-IDReq (link_identification_req) the IUT shall send a message containing the link_control_function IE FE-IDAck (link_identification_ack) and frames with S_{a7} bit set to zero.

On receipt of a message containing the link_control_function IE FE-IDRel (link_identification_rel) the IUT shall send frames with S_{a7} bit set to one.

4.3.5 Common test steps

The contents of this subclause are identical to subclause 4.3.5 of ETS 300 324-5 [1].

4.4 Defaults

The contents of this subclause are identical to subclause 4.4 of ETS 300 324-5 [1].

4.5 Abstract Service Primitives (ASPs) and Protocol Data Units (PDUs)

4.5.1 ASPs

The contents of this subclause are identical to subclause 4.5.1 of ETS 300 324-5 [1].

4.5.2 PDUs

4.5.2.1 Common control protocol

The contents of this subclause are identical to subclause 4.5.2.1 of ETS 300 324-5 [1].

4.5.2.2 Port control protocol

The contents of this subclause are identical to subclause 4.5.2.2 of ETS 300 324-5 [1].

4.5.2.3 PSTN protocol

The contents of this subclause are identical to subclause 4.5.2.3 of ETS 300 324-5 [1].

4.5.2.4 Link control protocol

link_ctrl
link_ctrl_ack

4.5.2.5 BCC protocol

bcc_allocation
bcc_allocation_complete
bcc_allocation_reject
bcc_deallocation
bcc_deallocation_complete
bcc_deallocation_reject
bcc_audit
bcc_audit_complete
bcc_an_fault
bcc_an_fault_ack
bcc_protocol_error

4.5.2.6 Protection protocol

protect_switch_over_req
protect_switch_over_com
protect_os_switch_over_com
protect_switch_over_ack
protect_switch_over_reject
protect_protocol_error
protect_reset_sn_com
protect_reset_sn_ack

4.5.3 Information elements

4.5.3.1 Variable length information elements

4.5.3.1.1 Control protocol

The contents of this subclause are identical to subclause 4.5.3.1.1 of ETS 300 324-5 [1].

4.5.3.1.2 PSTN protocol

The contents of this subclause are identical to subclause 4.5.3.1.2 of ETS 300 324-5 [1].

4.5.3.1.3 Link control protocol

link_control_function

4.5.3.1.4 BCC protocol

bcc_user_port_ident
bcc_ISDN_port_channel_ident
bcc_V5-time_slot_ident
bcc_multi_slot_map
bcc_rejection_cause
bcc_protocol_error_cause
bcc_connection-incomplete

4.5.3.1.5 Protection protocol

protect_sequence_number
protect_physical_c_channel_ident
protect_logical_c_channel_ident
protect_rejection_cause
protect_protocol_error_cause

4.5.3.2 Single octet information elements

4.5.3.2.1 Control protocol

The contents of this subclause are identical to subclause 4.5.3.2.1 of ETS 300 324-5 [1].

4.5.3.2.2 PSTN protocol

The contents of this subclause are identical to subclause 4.5.3.2.2 of ETS 300 324-5 [1].

4.5.3.2.3 Link control protocol

There are no single octet information elements defined within the Link control protocol.

4.5.3.2.4 BCC protocol

There are no single octet information elements defined within the BCC protocol.

4.5.3.2.5 Protection protocol

There are no single octet information elements defined within the Protection protocol.

4.6 Timers and counters of the Abstract Test Suite (ATS)

This subclause describes the timers and counters used in the ATS. The **min** and **max** indications define if the timer value represents the minimum or maximum limit of a timer. The timer values contain some additional tolerances for delays caused by test simulators. Therefore, a bigger timer tolerance is given than defined in ETS 300 347-1 [2]:

| | | |
|----------------------------|---|--------------------------------|
| Minimum value of ATS timer | = | ETS timer - ETS tolerance; |
| Maximum value of ATS timer | = | ETS timer + 2 x ETS tolerance. |

The repetition of messages by the IUT shall be tested in the following way: The message has to be repeated within the time period $T_{\min} < T < T_{\max}$. This testing procedure applies to the tests in the TI-test group only.

Table 2 gives the ATS timers which are used in addition to those defined in subclause 4.6 of ETS 300 324-5 [1].

Table 2: ATS timer values and references to ETS 300 347-1 [2]

| ATS timer name | ATS timer value [s] | ETS timer name | Reference to ETS 300 347-1 [2] |
|----------------|---------------------|-------------------------|--------------------------------|
| LCTO1_max | 1,2 | LCTO1 | clause 16, table 23 |
| LCTO1_min | 0,9 | | |
| TPERS_max | 0,15- 30 | Persistence check timer | subclause 16.1.3 |
| TPERS_min | 0,05 - 22,5 | | |
| TBCC1_max | 0,6 - 1,8 | TBCC1 | clause 17, table 46 |
| TBCC1_min | 0,45 - 1,2 | | |
| TBCC2_max | 2,4 | TBCC2 | clause 17, table 46 |
| TBCC2_min | 1,8 | | |
| TBCC3_max | 2,4 | TBCC3 | clause 17, table 46 |
| TBCC3_min | 0,8 | | |
| TBCC4_max | 0,6 - 1,8 | TBCC4 | clause 17, table 46 |
| TBCC4_min | 0,45 - 1,2 | | |
| TBCC5_max | 1,8 | TBCC5 | clause 17, table 46 |
| TSO1_max | 1,8 | TSO1 | clause 18, table 64 |
| TSO1_min | 1,2 | | |
| TSO2_max | 1,8 | TSO2 | clause 18, table 64 |
| TSO2_min | 1,2 | | |
| TSO3_max | 1,8 | TSO3 | clause 18, table 64 |
| TSO4_max | 24 | TSO4 | clause 18, table 64 |
| TSO4_min | 18 | | |
| TSO5_max | 12 | TSO5 | clause 18, table 64 |
| TSO5_min | 9 | | |

Table 3 gives the ATS counters which are used in addition to those defined in subclause 4.6 of ETS 300 324-5 [1].

Table 3: Protocol counter values and references to ETS 300 347-1 [2]

| ATS counter name | ATS counter value | Explanation | Reference to ETS 300 347-1 [2] |
|------------------|-------------------|---|--------------------------------|
| NLCO1 | 1 | Allowed number of repetitions of the LINK CONTROL message | clause 16, table 23 |
| NBCC1 | 1 | Allowed number of repetitions of the ALLOCATION message | clause 17, table 46 |
| NBCC2 | 1 | Allowed number of repetitions of the DEALLOCATION message in state LEBcc2 | clause 17, table 46 |
| NBCC3 | 1 | Allowed number of repetitions of the DEALLOCATION message in state LEBcc3 | clause 17, table 46 |
| NBCC4 | 1 | Allowed number of repetitions of the AUDIT message | clause 17, table 46 |
| NSO1 | 1 | Allowed number of repetitions of the SWITCH OVER COM message | clause 18, table 64 |
| NSO2 | 1 | Allowed number of repetitions of the OS SWITCH OVER REQ message | clause 18, table 64 |
| NSO4 | 1 | Allowed number of repetitions of the RESET SN COM message | clause 18, table 64 |

5 Test Purposes (TPs)

5.1 Introduction

The contents of this subclause are identical to subclause 5.1 of ETS 300 324-5 [1] and also valid for the V5.2 interface.

5.1.1 Test purpose naming convention

The identifier of a test purpose is built according to the scheme described in figure 4.

Table 4: Test purpose identifier naming convention scheme

| Identifier: | TP<t><c><g1><g2><tpt><s><ss><nn> | | | |
|-------------|----------------------------------|--------------------|---------|--|
| <t> | = | type of protocol: | 1 | Control protocol |
| | | | 2 | PSTN protocol |
| | | | 3 | Link control protocol |
| | | | 4 | BCC protocol |
| | | | 5 | Protection protocol |
| <c> | = | category: | 1 | IT, Basic Interconnection Tests |
| | | | 2 | CA, Capability Tests |
| | | | 3 | BV, Valid Behaviour Tests |
| | | | 4 | BO, Inopportune Behaviour Tests |
| | | | 5 | BI, Invalid Behaviour Tests |
| | | | 6 | TI, Timer Expiry and Counter Mismatch |
| <g1> | = | group level 1: | 1 | Common control |
| | | | 2 | Port control |
| | | | – | (underscore) Not relevant |
| <g2> | = | group level 2: | 1 | Transport |
| | | | 2 | System management procedure Restart |
| | | | 3 | System management procedure Re-provisioning & Verification |
| | | | 4 | PSTN |
| | | | 5 | ISDN-BA |
| | | | 6 | ISDN-PRA |
| | | | 7 | Link CTRL |
| | | | – | (underscore) Not relevant |
| <tpt> | = | test purpose type: | S | Single |
| | | | – | (underscore) Not relevant |
| <s> | = | state | (0-9) | |
| | | | M | Multiple state transition |
| | | | – | (underscore) Not relevant |
| <ss> | = | substate | (0-9) | |
| | | | – | (underscore) Not relevant |
| <nn> | = | sequential number | (01-99) | |

5.1.2 Source of test purpose definition

The TPs were developed based on ETS 300 347-1 [2], clauses 14 to 18 and annexes A to E.

5.1.3 Test strategy

5.1.3.1 Common control protocol

To achieve a maximum of test coverage with an appropriate number of TPs the following rules have been applied:

- a) the Common control protocol and the System management procedures are not tested on a per-state basis. The TPs step through the FSMs by testing the procedures and supervising the behaviour of the IUT at the V5.2 interface;
- b) the error handling procedures of the Common control protocol are not exhaustively tested. Not all possible combinations of protocol errors in all protocol states are covered. The TPs cover only examples for each error handling procedure in state LE1 of the Common control protocol;
- c) for several TPs some activities by the testing person are required (invoking of certain procedures by the System Under Test (SUT)). These TPs are marked with (*).

5.1.3.2 Port control protocol

To achieve a maximum of test coverage with an appropriate number of TPs the following rules have been applied:

- a) the Port control protocol, the ISDN-BA user port FSM, the ISDN-PRA user port FSM and the PSTN user port FSM are not tested on a per-state basis. The TPs step through the FSMs by testing the procedures and supervising the behaviour of the IUT at the V5.2 interface;
- b) the error handling procedures of the Port control protocol are not exhaustively tested. Not all possible combinations of protocol errors in all protocol states are covered. The TPs cover only examples for each error handling procedure in state LE1 of the Port control protocol. During these tests the PSTN, ISDN-BA and ISDN-PRA user port FSMs stay in state LE1.0;
- c) for several TPs some activities by the testing person are required (invoking of certain procedures by the SUT). These TPs are marked with (*);
- d) blocking of an ISDN-PRA port by sending a FE204 (block_cmd) to the IUT is always followed by sending a FE209 (TE_out_of_service) or FE220 (failure_inside_network) (see subclause 15.3.3.3.5 of ETS 300 347-1 [2]).

5.1.3.3 PSTN protocol

To achieve a maximum of test coverage with an appropriate number of TPs the following rules have been applied:

- a) only the first up to the third values of the PSTN sequence number variables S(S), S(A), S(R), M(S), M(R) is covered;
- b) the error handling procedures of the PSTN protocol are not exhaustively tested. Not all possible combinations of protocol errors in all protocol states are covered. The TPs cover only examples for each error handling procedure in PSTN_path_state LE1. To easily perform some of the abstract test cases, some procedures are tested in PSTN_path_state LE4;
- c) the procedure for unexpected events of the PSTN protocol is exhaustively tested (all unexpected events in all PSTN_path_states are covered);

- d) for several TPs some activities by the testing person are required (invoking of certain procedures by the SUT). These TPs are marked with (*);
- e) There is a full reference to ETS 300 324-5 [1] given for PSTN TPs (see subclause 5.3). The co-ordination between the PSTN and the BCC protocol affects only the PSTN state transitions and state checks (refer to subclauses 4.3.1.5 and 4.3.4).

5.1.3.4 Link control protocol

To achieve a maximum of test coverage with an appropriate number of TPs the following rules have been applied:

- a) the Link control protocol and the Link Control FSM are not tested on a per-state basis. The TPs step through the FSMs by testing the procedures and supervising the behaviour of the IUT at the V5.2 interface;
- b) the error handling procedures of the Link control protocol are not exhaustively tested. Not all possible combinations of protocol errors in all protocol states are covered. The test purposes cover only examples for each error handling procedure in state LE1 of the Link control protocol. During these tests the Link control FSM stays in state LE2.0;
- c) for several TPs some activities by the testing person are required (invoking of certain procedures by the SUT). These TPs are marked with (*);
- d) if PICS item N9 (see ETS 300 347-2 [3]) is set to yes, there may be an impact of link control procedures on protection switching. This impact is tested in subclause 5.6. Refer to subclause 5.1.6 for the configuration which is required for the link control tests;
- e) if PICS item N9 (see ETS 300 347-2 [3]) is set to no, persistent link failures are not tested in the link control test group;

NOTE: In this case, persistent link failures generate data link failures which are covered by ETS 300 347-7.

- f) if PICS item N9 (see ETS 300 347-2 [3]) is set to no, only the remote link blocking procedure is tested because blocking of a V5.2 link in a single link configuration may take the complete interface out of service;
- g) after each TP the remote link identification procedure is applied to check that the link is still operational.

5.1.3.5 BCC protocol

To achieve a maximum of test coverage with an appropriate number of TPs the following rules have been applied:

- a) the BCC protocol is not tested on a per-state basis. The TPs step through the FSM by testing the procedures and supervising the behaviour of the IUT at the V5.2 interface;
- b) the BCC protocol is tested by using PSTN or ISDN call control procedures. Therefore, the co-ordination of the BCC protocol and the call control procedures is covered implicitly by the BCC TPs;
- c) the error handling procedures of the BCC protocol are not exhaustively tested. Not all possible combinations of protocol errors in all protocol states are covered. The test purposes cover only examples for each error handling procedure in states LEBcc0 or LEBcc1 of the BCC protocol;
- d) for several TPs some activities by the testing person are required (invoking of certain procedures by the SUT). These TPs are marked with (*).

5.1.3.6 Protection protocol

To achieve a maximum of test coverage with an appropriate number of TPs the following rules have been applied:

- a) the Protection protocol is not tested on a per-state basis. The TPs step through the FSM by testing the procedures and supervising the behaviour of the IUT at the V5.2 interface;
- b) the error handling procedures of the Protection protocol are not exhaustively tested. Not all possible combinations of protocol errors in all protocol states are covered. The test purposes cover only examples for each error handling procedure in state SOLE0 of the Protection protocol;
- c) for several TPs some activities by the testing person are required (invoking of certain procedures by the SUT). These TPs are marked with (*);
- d) there are three monitor functions defined which can create trigger events for an autonomous protection switch-over:
 - layer 1 monitoring (trigger event: failure of a V5.2 link; refer to subclause 18.1.5.1 of ETS 300 347-1 [2]);
 - flag monitoring (trigger event: absence of flags, refer to subclause 18.1.5.2 of ETS 300 347-1 [2]);
 - data link monitoring (trigger event: data link failure, refer to subclause 18.1.5.3 of ETS 300 347-1 [2]).

The TPs use the generic term "prot_switch_over trigger event" to indicate any output of the monitor functions. Each TP using that term is valid for any trigger event.

5.1.4 Requirements not covered by test purposes

The contents of this subclause are identical to subclause 5.1.4 of ETS 300 324-5 [1] with the following additional items.

- it is not possible to verify explicitly the state of the ISDN-PRA port FSM, Link control protocol, the BCC protocol and the Protection protocol;
- the interworking between the Link Control FSM and the BCC protocol (releasing of seized bearer channels on a blocked V5.2 link) is not tested;
- since state SOLE2 of the LE Protection protocol FSM is fully controlled by the LE system management and, therefore, is an absolutely transient state, it was not possible to define BO tests for the LE Protection protocol.

5.1.5 Initial states

The initial states of the various V5.2 protocols are defined as follows:

| | |
|-----------------------|---|
| CTRL_COM_INIT | Refer to subclause 5.1.5 of ETS 300 324-5 [1] |
| CTRL_PORT_INIT | This state is identical to the state in subclause 5.1.5 of ETS 300 324-5 [1] with addition of ISDN-PRA. |
| PSTN_INIT | Refer to subclause 5.1.5 of ETS 300 324-5 [1] |
| LINK_INIT | Initial state to start preambuling the LINK test purposes |
| LE1 | (In Service State), Link control protocol |
| LE2.0 | (Link Operational State), Link Control FSM |

| | |
|------------------------------|--|
| BCC_INIT LEBcc0 | Initial state to start preambuling the BCC test purposes (Null State), BCC Protocol |
| PROTECT_INIT SOLE0 | Initial state to start preambuling the Protection test purposes Active and stand-by C-channels are allocated according to subclause 5.1.6. (Null State), Protection protocol |

5.1.6 Test and data configuration requirements

The contents of this subclause are identical to subclause 5.1.6 of ETS 300 324-5 [1] with the following additions.

Each V5.2-link shall be provisioned in a way, that the IUT tries to enter the link operational state after system startup.

If PICS item N9 (see ETS 300 347-2 [3]) is set to yes, only the primary and secondary link shall be provisioned. Protection group 1 (logical C-channel 1) shall contain the control, link control, BCC and protection C-paths.

Protection group 2 shall consist of the following constituents:

- a) if only one of the PICS items N11, N12 or N2 is set to yes (see ETS 300 347-2 [3]), the logical C-channel 2 shall contain the related C-path signalling;
- b) if at least two of the PICS items N11, N12 or N2 are set to yes (see ETS 300 347-2 [3]), the related C-paths shall be mapped to two logical C-channels (2 and 3).

The logical C-channel 2 shall be located on TS 15 of the primary link. The logical C-channel 3 (if present) shall be located on TS 31 of the primary link. TS 15 of the secondary link shall be provisioned as standby channel for protection group 2.

The secondary link will be used for testing the link control procedures without provoking protection switching.

If PICS item N12 (see ETS 300 347-2 [3]) is set to yes, only one ISDN-PRA port shall be provisioned.

On receipt of a MDU-LAI the IUT system management shall apply the link identification procedure.

5.2 Control protocol

5.2.1 Basic interconnection tests (V5NWKLE/CTRL/IT)

Initial state of the IUT: power on
Preamble: reset IUT
Postamble: -

TP11__SM_01 Run the test step STARTUP_LE (refer to subclause 4.3.1.1)
(*)

5.2.2 Capability tests (V5NWKLE/CTRL/CA)

The contents of this subclause are identical to subclause 5.2.2 of ETS 300 324-5 [1].

5.2.3 Valid behaviour tests (V5NWKLE/CTRL/BV)

5.2.3.1 V5NWKLE/CTRL/BV/COM

The contents of this subclause are identical to subclause 5.2.3.1 of ETS 300 324-5 [1].

5.2.3.2 V5NWKLE/CTRL/BV/PORT

5.2.3.2.1 V5NWKLE/CTRL/BV/PORT/TRANS

The contents of this subclause are identical to subclause 5.2.3.2.1 of ETS 300 324-5 [1].

5.2.3.2.2 V5NWKLE/CTRL/BV/PORT/PSTN

The contents of this subclause are identical to subclause 5.2.3.2.2 of ETS 300 324-5 [1].

5.2.3.2.3 V5NWKLE/CTRL/BV/PORT/ISDNBA

The contents of this subclause are identical to subclause 5.2.3.2.3 of ETS 300 324-5 [1].

5.2.3.2.4 V5NWKLE/CTRL/BV/PORT/ISDNPRA

Refer to the ETS 300 347-1 [2], table 8 and subclause L.2.3.

This test group is only valid if PICS item N12 (see ETS 300 347-2 [3]) is set to yes.

As the Port control protocol is tested separately (refer to subclause 5.2.3.2.1), the PORT CONTROL ACK messages are not mentioned in the following TPs any more.

Initial state of the IUT: CTRL_COM_INIT, CTRL_PORT_INIT

Preamble: CTRL_ISDNPRA_LE20_10

Postamble: CTRL_ISDNPRA_LE20_10

- TP1326S1001 (*) On receipt of a MPH-BI (block_cmd) the IUT shall send a message containing the control_function_element IE FE203 (block_cmd).
- TP1326S1002 On receipt of a PORT CONTROL message containing the control_function_element IE FE204 (block_cmd) the IUT shall send a PORT CONTROL ACK message, but no further event shall appear on the V5.2-interface.
- LT1 sends a PORT CONTROL message containing the control_function_element IE FE210 (failure_inside_network).
- TP1326S1003 On receipt of a PORT CONTROL message containing the control_function_element IE FE205 (block_req) the IUT shall send a PORT CONTROL ACK message, but no further event shall appear on the V5.2-interface.
- TP1326S1104 (*) Preamble:
On receipt of MPH-UBR (unblock_req) the IUT shall send a message containing the control_function_element IE FE201 (unblock_req) (IUT ISDN-PRA port FSM enters state LE1.1).
- On receipt of a PORT CONTROL message containing the control_function_element IE FE205 (block_req) the IUT shall send a PORT CONTROL ACK message, but no further event shall appear on the V5.2-interface.
- TP1326S1105 (*) Preamble:
On receipt of MPH-UBR (unblock_req) the IUT shall send a message containing the control_function_element IE FE201 (unblock_req) (IUT ISDN-PRA port FSM enters state LE1.1).
- On receipt of a PORT CONTROL message containing the control_function_element IE FE210 (failure_inside_network) the IUT shall send a PORT CONTROL ACK message, but no further event shall appear on the V5.2-interface.

TP1326SM_06 Verify "Repeated Local Unblocking".

(*)

Preamble:

On receipt of MPH-UBR (unlock_req) the IUT shall send a message containing the control_function_element IE FE201 (unlock_req) (IUT ISDN-PRA port FSM enters state LE1.1).

On receipt of a MPH-UBR (unlock_req) the IUT shall send a message containing the control_function_element IE FE201 (unlock_req).

LT1 sends a messages containing the control_function_element IE FE202 (unlock_ack) (IUT ISDN-PRA port FSM enters state LE2.0).

On receipt of a MPH-UBR (unlock_req) the IUT shall send a message containing the control_function_element IE FE201 (unlock_req).

TP1326SM_07 Verify "Local Unblocking/Blocking" procedure.

(*)

On receipt of MPH-UBR (unlock_req) the IUT shall send a message containing the control_function_element IE FE201 (unlock_req) (IUT ISDN-PRA port FSM enters state LE1.1).

LT1 sends a messages containing the control_function_element IE FE202 (unlock_ack) (IUT ISDN-PRA port FSM enters state LE2.0).

On receipt of a MPH-BI (block_cmd) the IUT shall send a message containing the control_function_element IE FE203 (block_cmd) (IUT ISDN-PRA port FSM enters state LE1.0).

TP1326SM_08 Verify "Remote Unblocking/Blocking" procedure.

On receipt of a message containing the control_function_element IE FE202 (unlock_req) the IUT shall send a message containing the control_function_element IE FE201 (unlock_ack) (IUT ISDN-PRA port FSM enters state LE2.0).

On receipt of a sequence of messages containing the control_function_element IEs FE202 (unlock_req), FE204 (block_cmd) (IUT ISDN-PRA port FSM enters state LE1.0) and FE202 (unlock_req) the IUT shall send a message containing the control_function_element IE FE201 (unlock_ack) (IUT ISDN-PRA port FSM enters state LE2.0).

TP1326SM_09 Verify "Blocking Request" procedure.

Preamble with CTRL_ISDNPRA_LE10_20.

On receipt of a message containing the control_function_element IE FE205 (block_req) the IUT shall send a message containing the control_function_element IE FE203 (block_cmd) (IUT ISDN-PRA port FSM enters state LE1.0).

TP1326SM_10 Verify "Rejected Unblocking" procedure.

(*)

On receipt of MPH-UBR (unlock_req) the IUT shall send a message containing the control_function_element IE FE201 (unlock_req) (IUT ISDN-PRA port FSM enters state LE1.1).

On receipt of a sequence of messages containing the control_function_element IEs FE209 (TE_out_of_service), FE204 (block_cmd) (IUT ISDN-PRA port FSM enters state LE1.0) and FE202 (unlock_req) the IUT shall send a message containing the control_function_element IE FE201 (unlock_ack) (IUT ISDN-PRA port FSM enters state LE2.0).

- TP1326SM_11 (*) Verify "Cancelled Unblocking" procedure.
- On receipt of MPH-UBR (unlock_req) the IUT shall send a message containing the control_function_element IE FE201 (unlock_req) (IUT ISDN-PRA port FSM enters state LE1.1).
- On receipt of a MPH-BI (block_cmd) the IUT shall send a message containing the control_function_element IE FE203 (block_cmd) (IUT ISDN-PRA port FSM enters state LE1.0).
- TP1326S2012 Preamble with CTRL_ISDNPRA_LE10_20.
- On receipt of a PORT CONTROL message containing the control_function_element IE FE206 (grading) the IUT shall send a PORT CONTROL ACK message, but no further event shall appear on the V5.2-interface.

5.2.4 Inopportune behaviour tests (V5NWKLE/CTRL/BO)

5.2.4.1 V5NWKLE/CTRL/BO/COM

The contents of this subclause are identical to subclause 5.2.4.1 of ETS 300 324-5 [1].

5.2.4.2 V5NWKLE/CTRL/BO/PORT

5.2.4.2.1 V5NWKLE/CTRL/BO/PORT/TRANS

The contents of this subclause are identical to subclause 5.2.4.2.1 of ETS 300 324-5 [1].

5.2.4.2.2 V5NWKLE/CTRL/BO/PORT/ISDNBA

The contents of this subclause are identical to subclause 5.2.4.2.2 of ETS 300 324-5 [1].

5.2.4.2.3 V5NWKLE/CTRL/BO/PORT/ISDNPRA

Refer to the ETS 300 347-1 [2], table 8 and subclause L.2.3.

This test group is only valid if PICS item N12 (see ETS 300 347-2 [3]) is set to yes.

Initial state of the IUT: CTRL_COM_INIT, CTRL_PORT_INIT
Preamble: CTRL_ISDNPRA_LE20_10
Postamble:

- TP1426S1001 On receipt of a PORT CONTROL message containing the control_function_element IE FE206 (grading) the IUT shall send a PORT CONTROL ACK message, but no further event shall appear on the V5.2-interface.
- TP1426S1102 (*) Preamble:
On receipt of MPH-UBR (unlock_req) the IUT shall send a message containing the control_function_element IE FE201 (unlock_req) (IUT ISDN-PRA port FSM enters state LE1.1).
- On receipt of a PORT CONTROL message containing the control_function_element IE FE206 (grading) the IUT shall send a PORT CONTROL ACK message, but no further event shall appear on the V5.2-interface.
- TP1426S2003 Preamble: CTRL_ISDNPRA_LE10_20.
- On receipt of a PORT CONTROL message containing the control_function_element IE FE209 (TE_out_of_service) the IUT shall send a PORT CONTROL ACK message, but no further event shall appear on the V5.2-interface.

TP1426S2004 Preamble: CTRL_ISDNPRA_LE10_20.

On receipt of a PORT CONTROL message containing the control_function_element IE FE210 (failure_inside_network) the IUT shall send a PORT CONTROL ACK message, but no further event shall appear on the V5.2-interface.

5.2.5 Invalid behaviour tests (V5NWKLE/CTRL/BI)

The contents of this subclause are identical to subclause 5.2.5 of ETS 300 324-5 [1].

5.2.6 Timer expiry and counter mismatch tests (V5NWKLE/CTRL/TI)

The contents of this subclause are identical to subclause 5.2.6 of ETS 300 324-5 [1].

5.3 PSTN protocol

The contents of this subclause are identical to subclause 5.3 of ETS 300 324-5 [1].

5.4 Link control protocol

If PICS item N9 (see ETS 300 347-2 [3]) is set to yes, all LINK CONTROL messages shall contain the layer 3 address of the secondary link (if not stated otherwise).

5.4.1 Basic interconnection tests (V5NWKLE/LINK/IT)

Initial state of the IUT: LINK_INIT
Preamble: -
Postamble: -

TP31__SM_01 Refer to TP11__SM_01 in subclause 5.2.1.

5.4.2 Capability tests (V5NWKLE/LINK/CA)

Refer to the ETS 300 347-1 [2], table 25.

Initial state of the IUT: LINK_INIT
Preamble: -
Postamble: -

TP32_1S1_01 On receipt of a LINK CONTROL message containing the link_control_function IE FE302 (link_unblock_req), the IUT shall send a LINK CONTROL ACK message containing the same link_control_function IE.

5.4.3 Valid behaviour tests (V5NWKLE/LINK/BV)

5.4.3.1 V5NWKLE/LINK/BV/TRANS

Refer to the ETS 300 347-1 [2], table 25.

Initial state of the IUT: LINK_INIT
Preamble: -
Postamble: -

TP33_1S1_01 Refer to TP32__S1_01 in subclause 5.4.2.

TP33_1SM_02 (*) On receipt of a FE301 (link_unblock_req) the IUT shall send a LINK CONTROL message containing the control_function_element IE FE301 (link_unblock_req).

On receipt of a LINK CONTROL ACK containing the control_function_element IE FE301 (link_unblock_req) the IUT shall not repeat the original message.

TP33_1SM_03 (*) Check that the IUT is able to control messages in both directions at the same time:

On receipt of a FE301 (link_unblock_req) the IUT shall send a LINK CONTROL message containing the link_control_function IE FE301 (link_unblock_req).

On receipt of a LINK CONTROL message containing the link_control_function IE FE302 (link_unblock_req), the IUT shall send a LINK CONTROL ACK message containing the same link_control_function IE.

On receipt of a LINK CONTROL ACK message containing the link_control_function IE FE301 (link_unblock_req), the IUT shall not repeat the original message.

5.4.3.2 V5NWKLE/LINK/BV/LINK

Refer to the ETS 300 347-1 [2], table 17.

As the Link control protocol is tested separately (refer to subclause 5.2.3.2.1), the LINK CONTROL ACK messages are not mentioned in the following TPs any longer.

Initial state of the IUT: LINK_INIT
Preamble: -
Postamble: LINK_CHECK_ID

TP33_7S2001 (*) Non-persistent V5.2 link failure while link is operational.

On detection of a non-persistent V5.2 link failure condition (AIS or RAI which disappears before expiration of TPERS, IUT Link Control FSM receives MPH_AI in state LE2.0) no message shall appear on the V5.2 interface.

TP33_7S1002 (*) Non-persistent V5.2 link failure while link is blocked.
(note 1) Preamble: LINK_LE20_10.

On detection of a non-persistent V5.2 link failure condition (AIS or RAI which disappears before expiration of TPERS, IUT Link Control FSM receives MPH_AI in state LE1.0) no message shall appear on the V5.2 interface.

After LT1 has unblocked the link (LINK_LE10_20) the IUT shall invoke the local link identification procedure.

No postamble needed.

TP33_7S1103 (*) Non-persistent V5.2 link failure while link is local unblocked.
(note 1) Preamble: LINK_LE20_10.

On receipt of a MDU-LUBR (link_unblock_req) the IUT shall send a message containing the link_control_function IE FE301 (link_unblock_req).

On detection of a non-persistent V5.2 link failure condition (AIS or RAI which disappears before expiration of TPERS, IUT Link Control FSM receives MPH_AI in state LE1.1) no message shall appear on the V5.2 interface.

Postamble:
LT1 sends a message containing the link_control_function IE FE302 (link_unblock_ack).

TP33_7S2204 Non-persistent V5.2 link failure while local link identification procedure.

(*)

Preamble:

On receipt of a MDU-IDReq (link_identification_req) the IUT shall send a message containing the link_control_function IE FE-IDReq (link_identification_req).

On detection of a non-persistent V5.2 link failure condition (AIS or RAI which disappears before expiration of TPERs, IUT Link Control FSM receives MPH_AI in state LE2.2) no message shall appear on the V5.2 interface.

Postamble:

LT1 sends a message containing the link_control_function IE FE-IDRej (link_identification_rej).

TP33_7S2105 Non-persistent V5.2 link failure while remote link identification procedure.

(*)

Preamble:

On receipt of a message containing the link_control_function IE FE-IDReq (link_identification_req) the IUT shall send a message containing the link_control_function IE FE-IDAck (link_identification_ack) and frames with S_{a7} bit set to zero.

On detection of a non-persistent V5.2 link failure condition (AIS or RAI which disappears before expiration of TPERs, IUT Link Control FSM receives MPH_AI in state LE2.1) no message shall appear on the V5.2 interface.

Postamble:

LT1 sends a message containing the link_control_function IE FE-IDRel (link_identification_rel).

TP33_7SM_06 Persistent V5.2 link failure while link is operational.

(*)

(note 1)

On detection of a persistent V5.2 link failure condition (AIS or RAI persists until the expiration of TPERs, IUT Link Control FSM receives MPH_DI and enters state LE0.1) no message shall appear on the V5.2 interface.

After the disappearance of the V5.2 link failure condition (IUT Link Control FSM receives MPH_AI and enters state LE2.0) the IUT shall invoke the local link identification procedure (see subclause 5.1.6, IUT system management receives MDU_LAI).

No postamble needed.

TP33_7SM_07 Persistent V5.2 link failure while link is blocked.

(*)

(note 1)

Preamble: LINK_LE20_10

On detection of a persistent V5.2 link failure condition (AIS or RAI persists until the expiration of TPERs, IUT Link Control FSM receives MPH_DI and enters state LE0.2) no message shall appear on the V5.2 interface.

After the disappearance of the V5.2 link failure condition (IUT Link Control FSM receives MPH_AI and enters state LE1.0) no message shall appear on the V5.2 interface.

After LT1 has unblocked the link (LINK_LE10_20) the IUT shall invoke the local link identification procedure.

No postamble needed.

- TP33_7SM_08 Persistent V5.2 link failure while link is local unblocked.
(*
(note 1)
- Preamble:
LINK_LE20_10.
On receipt of a MDU-LUBR (link_unblock_req) the IUT shall send a message containing the link_control_function IE FE301 (link_unblock_req).
- On detection of a persistent V5.2 link failure condition (AIS or RAI persists until the expiration of TPERs, IUT Link Control FSM receives MPH_DI and enters state LE0.2) no message shall appear on the V5.2 interface.
- After the disappearance of the V5.2 link failure condition (IUT Link Control FSM receives MPH_AI and enters state LE1.0) no message shall appear on the V5.2 interface.
- After LT1 has unblocked the link (LINK_LE10_20) the IUT shall invoke the local link identification procedure.
- No postamble needed.
- TP33_7SM_09 Persistent V5.2 link failure while local link identification procedure.
(*
(note 1)
- Preamble:
On receipt of a MDU-IDReq (link_identification_req) the IUT shall send a message containing the link_control_function IE FE-IDReq (link_identification_req).
- On detection of a persistent V5.2 link failure condition (AIS or RAI persists until the expiration of TPERs, IUT Link Control FSM receives MPH_DI and enters state LE0.1) the IUT shall send a message containing the link_control_function IE FE-IDRel (link_identification_rel).
- After the disappearance of the V5.2 link failure condition (IUT Link Control FSM receives MPH_AI and enters state LE2.0) the IUT shall invoke the local link identification procedure (see subclause 5.1.6, IUT system management receives MDU_LAI).
- No postamble needed.
- TP33_7SM_10 Persistent V5.2 link failure while remote link identification procedure.
(*
(note 1)
- Preamble:
On receipt of a message containing the link_control_function IE FE-IDReq (link_identification_req) the IUT shall send a message containing the link_control_function IE FE-IDAck (link_identification_ack) and frames with S_{a7} bit set to zero.
- On detection of a persistent V5.2 link failure condition (AIS or RAI persists until the expiration of TPERs, IUT Link Control FSM receives MPH_DI and enters state LE0.1) the IUT no message shall appear on the V5.2 interface.
- LT1 sends a message containing the link_control_function IE FE-IDRel (link_identification_rel)
- After the disappearance of the V5.2 link failure condition (IUT Link Control FSM receives MPH_AI and enters state LE2.0) the IUT shall invoke the local link identification procedure (see subclause 5.1.6, IUT system management receives MDU_LAI).
- No postamble needed.

- TP33_7SM_11 (*)
(note 1) Verify "Local Link Blocking/Unblocking" procedure while link is operational.
- On receipt of a MDU-LBI (link_block_cmd) the IUT shall send a message containing the link_control_function IE FE303 (link_block_cmd).
- On receipt of a MDU-LUBR (link_unblock_req) the IUT shall send a message containing the link_control_function IE FE301 (link_unblock_req).
- LT1 sends a message containing the link_control_function IE FE302 (link_unblock_ack) (IUT Link Control FSM enters state LE2.0).
- TP33_7S1112 (*)
(note 1) Verify "Repeated Local Link Unblocking" procedure.
- Preamble: LINK_LE20_10
On receipt of a MDU-LUBR (link_unblock_req) the IUT shall send a message containing the link_control_function IE FE301 (link_unblock_req).
- On receipt of a second MDU-LUBR (link_unblock_req) the IUT shall repeat the message containing the link_control_function IE FE301 (link_unblock_req).
- Additional postamble:
LT1 sends a message containing the link_control_function IE FE302 (link_unblock_ack) (IUT Link Control FSM enters state LE2.0).
- TP33_7S1113 (*)
(note 1) Verify "Cancelled Link Unblocking" procedure.
- Preamble: LINK_LE20_10
On receipt of a MDU-LUBR (link_unblock_req) the IUT shall send a message containing the link_control_function IE FE301 (link_unblock_req).
- On receipt of a MDU-LBI (link_block_cmd) the IUT shall send a message containing the link_control_function IE FE303 (link_block_cmd).
- Additional postamble: LINK_LE10_20.
- TP33_7S1114 (*)
(note 1) Verify "Rejected Link Unblocking" (FE304) procedure.
- Preamble: LINK_LE20_10
On receipt of a MDU-LUBR (link_unblock_req) the IUT shall send a message containing the link_control_function IE FE301 (link_unblock_req).
- On receipt of a message containing the link_control_function IE FE304 (link_block_cmd) (IUT Link control protocol enters state LE1.0) the IUT shall send a LINK CONTROL ACK message but no further event shall appear on the V5.2 interface.
- Additional postamble: LINK_LE10_20.
- TP33_7S1115 (*)
(note 1) Verify "Rejected Link Unblocking" (FE305) procedure.
- Preamble: LINK_LE20_10
On receipt of a MDU-LUBR (link_unblock_req) the IUT shall send a message containing the link_control_function IE FE301 (link_unblock_req).
- On receipt of a message containing the link_control_function IE FE305 (deferred_link_block_req) the IUT shall send message containing the link_control_function IE FE303 (link_block_cmd).
- Additional postamble: LINK_LE10_20.

- TP33_7S1116 (*)
(note 1) Verify "Rejected Link Unblocking" (FE306) procedure.
- Preamble: LINK_LE20_10
On receipt of a MDU-LUBR (link_unblock_req) the IUT shall send a message containing the link_control_function IE FE301 (link_unblock_req).
- On receipt of a message containing the link_control_function IE FE306 (non-deferred_link_block_req) the IUT shall send message containing the link_control_function IE FE303 (link_block_cmd).
- Additional postamble: LINK_LE10_20.
- TP33_7SM_17 (note 1) Verify "Remote Link Blocking/Unblocking" procedure while link is operational.
- On receipt of a sequence of messages containing the link_control_function IEs FE304 (link_block_cmd), again FE304 (link_block_cmd) and FE302 (link_unblock_req) the IUT shall send a message containing the link_control_function IE FE301 (link_unblock_ack).
- TP33_7SM_18 (note 2) Verify "Remote Link Blocking/Unblocking" procedure while link is operational.
- On receipt of a message containing the link_control_function IE FE304 (link_block_cmd) the IUT shall invoke the startup procedure (see subclause 4.3.1.1).
- TP33_7S2019 Verify "Remote Link Unblocking" procedure while link is operational.
- On receipt of a message containing the link_control_function IE FE302 (link_unblock_req) the IUT shall send a message containing the link_control_function IE FE301 (link_unblock_ack).
- TP33_7SM_20 (note 1) Verify "Deferred Link Blocking Request/Unblocking" procedure while link is operational.
- On receipt of a message containing the link_control_function IE FE305 (deferred_link_block_req) the IUT shall send a message containing the link_control_function IE FE303 (link_block_cmd).
- On receipt of a second message containing the link_control_function IE FE305 (deferred_link_block_req) the IUT shall repeat the message containing the link_control_function IE FE303 (link_block_cmd).
- On receipt of a message containing the link_control_function FE302 (link_unblock_req) the IUT shall send a message containing the link_control_function IE FE301 (link_unblock_ack).
- TP33_7SM_21 (note 1) Verify "Non-Deferred Link Blocking Request/Unblocking" procedure while link is operational.
- On receipt of a message containing the link_control_function IE FE306 (deferred_link_block_req) the IUT shall send a message containing the link_control_function IE FE303 (link_block_cmd).
- On receipt of a second message containing the link_control_function IE FE306 (deferred_link_block_req) the IUT shall repeat the message containing the link_control_function IE FE303 (link_block_cmd).
- On receipt of a message containing the link_control_function FE302 (link_unblock_req) the IUT shall send a message containing the link_control_function IE FE301 (link_unblock_ack).

TP33_7S2022 (note 2) Verify "Rejected Non-Deferred Link Blocking Request" procedure while link is operational.

On receipt of a message containing the link_control_function IE FE306 (non-deferred_link_block_req) the IUT shall send a message containing the link_control_function IE FE301 (link_unblock_ind).

TP33_7S2023 (note 2) Verify "Rejected Deferred Link Blocking Request" procedure while link is operational.

On receipt of a message containing the link_control_function IE FE305 (deferred_link_block_req) the IUT shall send a message containing the link_control_function IE FE301 (link_unblock_ind).

TP33_7SM_24 (*) (note 1) Verify "Local Blocking" procedure while persistent V5.2 link failure.

Preamble:

Detection of a persistent V5.2 link failure condition (AIS or RAI persists until the expiration of TPERs, IUT Link Control FSM receives MPH_DI and enters state LE0.1).

On receipt of a MDU-LBI (link_block_cmd) the IUT shall send a message containing the link_control_function IE FE303 (link_block_cmd).

After LT1 has unblocked the link (LINK_LE10_20) and the disappearance of the V5.2 link failure condition the IUT shall invoke the local link identification procedure.

No postamble needed.

TP33_7SM_25 (*) (note 1) Verify "Remote Blocking" procedure while persistent V5.2 link failure.

Preamble:

Detection of a persistent V5.2 link failure condition (AIS or RAI persists until the expiration of TPERs, IUT Link Control FSM receives MPH_DI and enters state LE0.1).

On receipt of a message containing the link_control_function IE FE304 (link_block_cmd) the IUT shall send a LINK CONTROL ACK message but no further event shall appear on the V5.2 interface.

On receipt of a second message containing the link_control_function IE FE304 (link_block_cmd) the IUT shall send a LINK CONTROL ACK message but no further event shall appear on the V5.2 interface.

On receipt of a message containing the link_control_function IE FE302 (link_unblock_req) the IUT shall send a message containing the link_control_function IE FE303 (link_block_cmd)

On receipt of a message containing the link_control_function IE FE305 (non-deferred_block_req) the IUT shall send a message containing the link_control_function IE FE303 (link_block_cmd)

On receipt of a message containing the link_control_function IE FE306 (deferred_block_req) the IUT shall send a message containing the link_control_function IE FE303 (link_block_cmd)

After LT1 has unblocked the link (LINK_LE10_20) and the disappearance of the V5.2 link failure condition the IUT shall invoke the local link identification procedure.

No postamble needed.

- TP33_7S2226
(*
(*)
- Verify "Non-deferred Blocking procedure" procedure while local link identification.
- Preamble:
On receipt of a MDU-IDReq (link_identification_req) the IUT shall send a message containing the link_control_function IE FE-IDReq (link_identification_req).
- On receipt of a message containing the link_control_function IE FE306 (non-deferred_block_req) the IUT shall send a message containing the link_control_function IE FE301 (link_unblock_ind).
- Postamble:
LT1 sends a message containing the link_control_function IE FE-IDRej (link_identification_rej).
- TP33_7SM_27
(*
(note 1)
- Verify "Deferred Blocking procedure" procedure while local link identification.
- Preamble:
On receipt of a MDU-IDReq (link_identification_req) the IUT shall send a message containing the link_control_function IE FE-IDReq (link_identification_req).
- On receipt of a message containing the link_control_function IE FE305 (deferred_block_req) the IUT shall send a LINK CONTROL ACK message but no further event shall appear on the V5.2 interface
- On receipt of a message containing the link_control_function IE FE-IDRej (link_identification_rej) the IUT shall send a message containing the link_control_function IE FE303 (link_block_cmd).
- Postamble: LINK_LE10_20.
- TP33_7S2228
(*
(note 1)
- Verify "Local Blocking procedure" procedure while local link identification.
- Preamble:
On receipt of a MDU-IDReq (link_identification_req) the IUT shall send a message containing the link_control_function IE FE-IDReq (link_identification_req).
- On receipt of a MDU-LBI (link_block_cmd) the IUT shall send a message containing the link_control_function IE FE303 (link_block_cmd).
- Postamble: LINK_LE10_20.
- TP33_7S2229
(*
(*)
- Verify "Remote Unblocking" procedure while local link identification.
- Preamble:
On receipt of a MDU-IDReq (link_identification_req) the IUT shall send a message containing the link_control_function IE FE-IDReq (link_identification_req).
- On receipt of a message containing the link_control_function IE FE302 (link_unblock_req) and a subsequent MDU-IDReq (link_identification_req) the IUT shall send a message containing the link_control_function IE FE-IDReq (link_identification_req).
- Postamble:
LT1 sends a message containing the link_control_function IE FE-IDRej (link_identification_rej).

- TP33_7S2230 (*)
(note 1) Verify "Remote Blocking" procedure while local link identification.
- Preamble:
On receipt of a MDU-IDReq (link_identification_req) the IUT shall send a message containing the link_control_function IE FE-IDReq (link_identification_req).
- On receipt of a message containing the link_control_function IE FE304 (link_block_cmd) the IUT shall send a LINK CONTROL ACK message but no further event shall appear on the V5.2 interface.
- Postamble: LINK_LE10_20.
- TP33_7S2131
(note 1) Verify "Non-deferred Blocking procedure" procedure while remote link identification.
- Preamble:
On receipt of a message containing the link_control_function IE FE-IDReq (link_identification_req) the IUT shall send a message containing the link_control_function IE FE-IDAck (link_identification_ack) and frames with S_{a7} bit set to zero.
- On receipt of a message containing the link_control_function IE FE306 (non-deferred_block_req) the IUT shall send a message containing the link_control_function IE FE303 (link_block_cmd) and frames with S_{a7} bit set to one.
- Postamble: LINK_LE10_20.
- TP33_7S2132
(note 2) Verify "Non-deferred Blocking procedure" procedure while remote link identification.
- Preamble:
On receipt of a message containing the link_control_function IE FE-IDReq (link_identification_req) the IUT shall send a message containing the link_control_function IE FE-IDAck (link_identification_ack) and frames with S_{a7} bit set to zero.
- On receipt of a message containing the link_control_function IE FE306 (non-deferred_block_req) the IUT shall send a message containing the link_control_function IE FE301 (link_unblock_ind).
- On receipt of a message containing the link_control_function IE FE-IDRel (link_identification_rel) the IUT shall send and frames with S_{a7} bit set to one.
- No postamble needed.
- TP33_7SM_33
(note 1) Verify "Deferred Blocking procedure" procedure while remote link identification.
- Preamble:
On receipt of a message containing the link_control_function IE FE-IDReq (link_identification_req) the IUT shall send a message containing the link_control_function IE FE-IDAck (link_identification_ack) and frames with S_{a7} bit set to zero.
- On receipt of a message containing the link_control_function IE FE305 (deferred_block_req) the IUT shall send a LINK CONTROL ACK message but no further event shall appear on the V5.2 interface.
- On receipt of a message containing the link_control_function IE FE-IDRel (link_identification_rel) the IUT shall send a message containing the link_control_function IE FE303 (link_block_cmd) and frames with S_{a7} bit set to one.
- Postamble: LINK_LE10_20.

- TP33_7S2134 Verify "Remote Unblocking" procedure while remote link identification
- Preamble:
On receipt of a message containing the link_control_function IE FE-IDReq (link_identification_req) the IUT shall send a message containing the link_control_function IE FE-IDAck (link_identification_ack) and frames with S_{a7} bit set to zero.
- On receipt of a message containing the link_control_function IE FE302 (link_unblock_req) the IUT shall send frames with S_{a7} bit set to one.
- TP33_7S2135
(note 1) Verify "Remote Blocking" procedure while remote link identification
- Preamble:
On receipt of a message containing the link_control_function IE FE-IDReq (link_identification_req) the IUT shall send a message containing the link_control_function IE FE-IDAck (link_identification_ack) and frames with S_{a7} bit set to zero.
- On receipt of a message containing the link_control_function IE FE304 (link_block_cmd) the IUT shall send frames with S_{a7} bit set to one.
- Postamble: LINK_LE10_20.
- TP33_7S0136
(*
(note 1) Preamble:
Detection of a persistent V5.2 link failure condition (AIS or RAI persists until the expiration of TPERs, IUT Link Control FSM receives MPH_DI and enters state LE0.1).
- On receipt of a message containing the link_control_function IE FE302 (link_unblock_req) the IUT shall send a message containing the link_control_function IE FE303 (link_block_cmd)
- After LT1 has unblocked the link (LINK_LE10_20) and the disappearance of the V5.2 link failure condition the IUT shall invoke the local link identification procedure.
- No postamble needed.
- TP33_7S0137
(*
(note 1) Preamble:
Detection of a persistent V5.2 link failure condition (AIS or RAI persists until the expiration of TPERs, IUT Link Control FSM receives MPH_DI and enters state LE0.1).
- On receipt of a message containing the link_control_function IE FE305 (non-deferred_block_req) the IUT shall send a message containing the link_control_function IE FE303 (link_block_cmd).
- After LT1 has unblocked the link (LINK_LE10_20) and the disappearance of the V5.2 link failure condition the IUT shall invoke the local link identification procedure.
- No postamble needed.

- TP33_7S0138 Preamble:
(*
(note 1) Detection of a persistent V5.2 link failure condition (AIS or RAI persists until the expiration of TPERs, IUT Link Control FSM receives MPH_DI and enters state LE0.1).
- On receipt of a message containing the link_control_function IE FE306 (deferred_block_req) the IUT shall send a message containing the link_control_function IE FE303 (link_block_cmd)
- After LT1 has unblocked the link (LINK_LE10_20) and the disappearance of the V5.2 link failure condition the IUT shall invoke the local link identification procedure.
- No postamble needed.
- TP33_7SM_39 Verify "Successful Local Link Identification" procedure while link is operational.
(*
- On receipt of a MDU-IDReq (link_identification_req) the IUT shall send a message containing the link_control_function IE FE-IDReq (link_identification_req).
- LT1 sends frames with S_{a7} bit set to zero.
- On receipt of a message containing the link_control_function IE FE-IDAck (link_identification_ack) the IUT shall send a message containing the link_control_function IE FE-IDRel (link_identification_rel).
- Postamble:
LT1 sends frames with S_{a7} bit set to one.
- TP33_7SM_40 Verify "Unsuccessful Local Link Identification" procedure while link is operational.
(*
- On receipt of a MDU-IDReq (link_identification_req) the IUT shall send a message containing the link_control_function IE FE-IDReq (link_identification_req).
- On receipt of a message containing the link_control_function IE FE-IDAck (link_identification_ack) the IUT shall send a message containing the link_control_function IE FE-IDRel (link_identification_rel).
- TP33_7SM_41 Verify "Rejected Local Link Identification" procedure while link is operational.
(*
- On receipt of a MDU-IDReq (link_identification_req) the IUT shall send a message containing the link_control_function IE FE-IDReq (link_identification_req).
- On receipt of a message containing the link_control_function IE FE-IDRej (link_identification_rej) the IUT shall send a LINK CONTROL ACK message but no further message shall appear on the V5.2 interface.
- TP33_7SM_42 Verify "Successful Remote Link Identification" procedure while link is operational.
- On receipt of a message containing the link_control_function IE FE-IDReq (link_identification_req) the IUT shall send a message containing the link_control_function IE FE-IDAck (link_identification_ack) and frames with S_{a7} bit set to zero.
- On receipt of a second message containing the link_control_function IE FE-IDReq (link_identification_req) the IUT shall send a LINK CONTROL ACK message but no further message shall appear on the V5.2 interface.
- On receipt of a message containing the link_control_function IE FE-IDRel (link_identification_rel) the IUT shall send frames with S_{a7} bit set to one.
- No postamble needed.

- TP33_7S2243
(*)
- Verify "Link Identification Collision" procedure on one link.
- Preamble:
On receipt of a MDU-IDReq (link_identification_req) the IUT shall send a message containing the link_control_function IE FE-IDReq (link_identification_req).
- On receipt of a message containing the link_control_function IE FE-IDReq (link_identification_req) for the same link the IUT shall send a message containing the link_control_function IE FE-IDRej (link_identification_rej).
- Postamble:
LT1 sends a message containing the link_control_function IE FE-IDRej (link_identification_rej).
- TP33_7S2244
(*)
(note 1)
- Verify "Link Identification Collision" procedure on different links.
- Preamble:
On receipt of a MDU-IDReq (link_identification_req) the IUT shall send a message containing the link_control_function IE FE-IDReq (link_identification_req).
- On receipt of a message containing the link_control_function IE FE-IDReq (link_identification_req) and the Layer 3 Address of the primary link, the IUT shall send a message containing the link_control_function IE FE-IDRej (link_identification_rej) and the Layer 3 Address of the primary link.
- Postamble:
LT1 sends a message containing the link_control_function IE FE-IDRej (link_identification_rej).
- TP33_7S1045
(note 1)
- Verify "Remote Link Identification" procedure while link is blocked.
- Preamble: LINK_LE20_10
- On receipt of a message containing the link_control_function IE FE-IDReq (link_identification_req) the IUT shall send a message containing the link_control_function IE FE303 (link_block_cmd).
- Additional postamble: LINK_LE10_20.
- TP33_7S1046
(note 1)
- Preamble: LINK_LE20_10
- On receipt of a message containing the link_control_function IE FE-IDRel (link_identification_rel) the IUT shall send a LINK CONTROL ACK message but no further event shall appear on the V5.2 interface.
- Additional postamble: LINK_LE10_20.
- TP33_7S1047
(note 1)
- Preamble: LINK_LE20_10
- On receipt of a message containing the link_control_function IE FE-IDRej (link_identification_rej) the IUT shall send a LINK CONTROL ACK message but no further event shall appear on the V5.2 interface.
- Additional postamble: LINK_LE10_20.

TP33_7S1148 Preamble: LINK_LE20_10

(*)

(note 1)

On receipt of a MDU-LUBR (link_unblock_req) the IUT shall send a message containing the link_control_function IE FE301 (link_unblock_req).

On receipt of a message containing the link_control_function IE FE-IDReq (link_identification_req) the IUT shall send a message containing the link_control_function IE FE-IDRej (link_identification_rej).

Additional postamble: LINK_LE10_20.

TP33_7S1149 Preamble: LINK_LE20_10

(*)

(note 1)

On receipt of a MDU-LUBR (link_unblock_req) the IUT shall send a message containing the link_control_function IE FE301 (link_unblock_req).

On receipt of a message containing the link_control_function IE FE-IDRel (link_identification_rel) the IUT shall send a LINK CONTROL ACK message but no further event shall appear on the V5.2 interface.

Additional postamble: LINK_LE10_20.

TP33_7S1150 Preamble: LINK_LE20_10

(*)

(note 1)

On receipt of a MDU-LUBR (link_unblock_req) the IUT shall send a message containing the link_control_function IE FE301 (link_unblock_req).

On receipt of a message containing the link_control_function IE FE-IDRej (link_identification_rej) the IUT shall send a LINK CONTROL ACK message but no further event shall appear on the V5.2 interface.

Additional postamble: LINK_LE10_20.

TP33_7SM_51 Remote link identification while persistent V5.2 link failure.

(*)

(note 1)

Preamble:

Detection of a persistent V5.2 link failure condition (AIS or RAI persists until the expiration of TPERs, IUT Link Control FSM receives MPH_DI and enters state LE0.1).

On receipt of a message containing the link_control_function IE FE-IDReq (link_identification_req) the IUT shall send a message containing the link_control_function IE FE303 (link_block_cmd).

On receipt of a second message containing the link_control_function IE FE-IDReq (link_identification_req) the IUT shall repeat the message containing the link_control_function IE FE303 (link_block_cmd).

After LT1 has unblocked the link (LINK_LE10_20) and the disappearance of the V5.2 link failure condition the IUT shall invoke the local link identification procedure.

No postamble needed.

TP33_7S0152 Preamble:
(*
(note 1) Detection of a persistent V5.2 link failure condition (AIS or RAI persists until the expiration of TPERs, IUT Link Control FSM receives MPH_DI and enters state LE0.1).

On receipt of a message containing the link_control_function IE FE-IDRrej (link_identification_rej) the IUT shall send a LINK CONTROL ACK message but no further event shall appear on the V5.2 interface.

After LT1 has unblocked the link (LINK_LE10_20) and the disappearance of the V5.2 link failure condition the IUT shall invoke the local link identification procedure.

No postamble needed.

NOTE 1: These TPs are only applicable if PICS item N9 (see ETS 300 347-2 [3]) is set to yes.

NOTE 2: These TPs are only applicable if PICS item N9 (see ETS 300 347-2 [3]) is set to no.

5.4.4 Inopportune behaviour tests (V5NWKLE/LINK/BO)

5.4.4.1 V5NWKLE/LINK/BO/TRANS

Refer to the ETS 300 347-1 [2], table 25.

Initial state of the IUT: LINK_INIT
Preamble: -
Postamble: -

TP34_1S1_01 On receipt of a LINK CONTROL ACK message the IUT shall ignore the message.

5.4.4.2 V5NWKLE/LINK/BO/LINK

Refer to the ETS 300 347-1 [2], table 17.

Initial state of the IUT: LINK_INIT
Preamble: -
Postamble: LINK_CHECK_ID

TP34_7S0101 Preamble:
(*
(note) Detection of a persistent V5.2 link failure condition (AIS or RAI persists until the expiration of TPERs, IUT Link Control FSM receives MPH_DI and enters state LE0.1).

On receipt of a message containing the link_control_function IE FE-IDAck (link_identification_ack) the IUT shall send a LINK CONTROL ACK message but no further event shall appear on the V5.2 interface.

On the disappearance of the V5.2 link failure condition the IUT shall invoke the local link identification procedure.

No postamble needed.

TP34_7S0202 Preamble:
(* LINK_LE20_10 and detection of a persistent V5.2 link failure condition (AIS or RAI
(note) persists until the expiration of TPERS, IUT Link Control FSM receives MPH_DI and enters state LE0.2).

On receipt of a message containing the link_control_function IE FE-IDAck (link_identification_ack) the IUT shall send a LINK CONTROL ACK message but no further event shall appear on the V5.2 interface.

After LT1 has unblocked the link (LINK_LE10_20) and the disappearance of the V5.2 link failure condition the IUT shall invoke the local link identification procedure.

No postamble needed.

TP34_7S0203 Preamble:
(* LINK_LE20_10 and detection of a persistent V5.2 link failure condition (AIS or RAI
(note) persists until the expiration of TPERS, IUT Link Control FSM receives MPH_DI and enters state LE0.2).

On receipt of a message containing the link_control_function IE FE-IDRel (link_identification_rel) the IUT shall send a LINK CONTROL ACK message but no further event shall appear on the V5.2 interface.

After LT1 has unblocked the link (LINK_LE10_20) and the disappearance of the V5.2 link failure condition the IUT shall invoke the local link identification procedure.

No postamble needed.

TP34_7S0204 Preamble:
(* LINK_LE20_10 and detection of a persistent V5.2 link failure condition (AIS or RAI
(note) persists until the expiration of TPERS, IUT Link Control FSM receives MPH_DI and enters state LE0.2).

On receipt of a message containing the link_control_function IE FE-IDRej (link_identification_rej) the IUT shall send a LINK CONTROL ACK message but no further event shall appear on the V5.2 interface.

After LT1 has unblocked the link (LINK_LE10_20) and the disappearance of the V5.2 link failure condition the IUT shall invoke the local link identification procedure.

No postamble needed.

TP34_7S1005 Preamble: LINK_LE20_10 .
(note)

On receipt of a message containing the link_control_function IE FE-IDAck (link_identification_ack) the IUT shall send a LINK CONTROL ACK message but no further event shall appear on the V5.2 interface.

Additional postamble: LINK_LE10_20.

TP34_7S1106 Preamble: LINK_LE20_10.
(*
(note)

On receipt of a MDU-LUBR (link_unblock_req) the IUT shall send a message containing the link_control_function IE FE301 (link_unblock_req).

On receipt of a message containing the link_control_function IE FE-IDAck (link_identification_ack) the IUT shall send a LINK CONTROL ACK message but no further event shall appear on the V5.2 interface.

Additional postamble: LINK_LE10_20.

- TP34_7S2007 On receipt of a message containing the link_control_function IE FE-IDAck (link_identification_ack) the IUT shall send a LINK CONTROL ACK message but no further event shall appear on the V5.2 interface.
- TP34_7S2008 On receipt of a message containing the link_control_function IE FE-IDRel (link_identification_rel) the IUT shall send a LINK CONTROL ACK message but no further event shall appear on the V5.2 interface.
- TP34_7S2009 On receipt of a message containing the link_control_function IE FE-IDRej (link_identification_rej) the IUT shall send a LINK CONTROL ACK message but no further event shall appear on the V5.2 interface.
- TP34_7S2110 Preamble:
On receipt of a message containing the link_control_function IE FE-IDReq (link_identification_req) the IUT shall send a message containing the link_control_function IE FE-IDAck (link_identification_ack) and frames with S_{a7} bit set to zero.
- On receipt of a message containing the link_control_function IE FE-IDRej (link_identification_rej) the IUT shall send a LINK CONTROL ACK message but no further event shall appear on the V5.2 interface.
- Postamble:
On receipt of a message containing the link_control_function IE FE-IDRel (link_identification_rel) the IUT shall send frames with S_{a7} bit set to one.
- TP34_7S2111 Preamble:
On receipt of a message containing the link_control_function IE FE-IDReq (link_identification_req) the IUT shall send a message containing the link_control_function IE FE-IDAck (link_identification_ack) and frames with S_{a7} bit set to zero.
- On receipt of a message containing the link_control_function IE FE-IDAck (link_identification_ack) the IUT shall send a LINK CONTROL ACK message but no further event shall appear on the V5.2 interface.
- Postamble:
On receipt of a message containing the link_control_function IE FE-IDRel (link_identification_rel) the IUT shall send frames with S_{a7} bit set to one.
- TP34_7S2212 (*) Preamble:
On receipt of a MDU-IDReq (link_identification_req) the IUT shall send a message containing the link_control_function IE FE-IDReq (link_identification_req).
- On receipt of a message containing the link_control_function IE FE-IDRel (link_identification_rel) the IUT shall send a LINK CONTROL ACK message but no further event shall appear on the V5.2 interface.
- Postamble:
LT1 sends a message containing the link_control_function IE FE-IDRej (link_identification_rej).

NOTE: These TPs are only applicable if PICS item N9 (see ETS 300 347-2 [3]) is set to yes.

5.4.5 Invalid behaviour tests (V5NWKLE/LINK/BI)

Refer to the ETS 300 347-1 [2], subclause 16.3.5.

5.4.5.1 V5NWKLE/LINK/BI/TRANS

Initial state of the IUT: LINK_INIT

Preamble: -

Postamble: -

TP35_1S1_01 Check that the IUT discards messages having less than 4 octets.

TP35_1S1_02 (protocol discriminator error)

Check that the IUT discards a message containing an unspecified protocol_discriminator IE.

TP35_1S1_03 (L3 address error)

Check that the IUT discards a message containing an unspecified L3addr IE.

TP35_1S1_04 (message type error)

Check that the IUT discards a message containing an unspecified message_type IE.

TP35_1S1_05 (repeated IE)

Check that the IUT discards a message containing two repeated link_control_function IEs.

TP35_1S1_06 (mandatory IE missing)

Check that the IUT discards a message containing no link_control_function IE.

TP35_1S1_07 (unrecognized IE)

Check that the IUT discards a message containing an unspecified link_control_function.

TP35_1S1_08 (content error of mandatory IE)

Check that the IUT discards a message containing an incorrect link_control_function IE.

5.4.6 Timer expiry and counter mismatch tests (V5NWKLE/LINK/TI)

5.4.6.1 V5NWKLE/LINK/TI/TRANS

Refer to the ETS 300 347-1 [2], table 25.

Initial state of the IUT: LINK_INIT
Preamble: -
Postamble: -

TP36_1S2_01 Preamble:
On receipt of a LINK CONTROL message containing the link_control_function IE FE302 (link_unblock_req) the IUT shall send a LINK CONTROL ACK message containing the same link_control_function IE.

On receipt of a FE301 (link_unblock_ack) the IUT shall send a LINK CONTROL message containing the link_control_function IE FE301 (link_unblock_ack).

On receipt of a LINK CONTROL ACK messages after NLCO1 repetitions of the LINK CONTROL message, the IUT shall stop repeating the original message.

TP36_1S2_02 Preamble:
On receipt of a LINK CONTROL message containing the link_control_function IE FE302 (unblock_req) the IUT shall send a LINK CONTROL ACK message containing the same link_control_function IE.

On receipt of a FE301 (link_unblock_ack) the IUT shall send a LINK CONTROL message containing the link_control_function IE FE301 (link_unblock_ack).

On receipt of a LINK CONTROL ACK message containing not the same link_control_function IE the IUT shall ignore the message.

On receipt of a LINK CONTROL ACK messages after NLCO1 repetitions of the LINK CONTROL message, the IUT shall stop repeating the original message.

5.5 BCC protocol

If not stated otherwise, the BCC messages sent by the IUT or LT1 shall have the following contents:

- a) the override bit in the V5_TS_ID IE shall be set to zero;
- b) each response of the IUT respectively LT1 on BCC messages shall contain the same reference_number IE as the original message;
- c) each BCC message sent by LT1 shall contain the V5_TS_ID IE pointing on the V5 TS which was selected by the IUT.

The global pre- and postambles depend on the provisioned data configuration with relation to the PICS items N11, N12 and N2 (see ETS 300 347-2 [3], subclause 6.6.1).

Preambles given in a specific TP have to be applied after performing the global preamble, specific postambles have to be applied before performing the global postamble.

5.5.1 Basic interconnection tests (V5NWKLE/BCC/IT)

Initial state of the IUT: BCC_INIT
Preamble: -
Postamble: -

TP41__SM_01 Refer to subclause 5.2.1, test purpose TP11__SM_01.

5.5.2 Capability tests (V5NWKLE/BCC/CA)

Refer to the ETS 300 347-1 [2], table 47 and Annex E.

Initial state of the IUT: BCC_INIT
Preamble: CTRL_PSTN_LE10_20, CTRL_ISDNBA_LE10_20, CTRL_ISDNPRA_LE10_20
Postamble: CTRL_PSTN_LE20_10, CTRL_ISDNBA_LE20_10, CTRL_ISDNPRA_LE20_10

TP42__SM_01 "PSTN call establishment and release initiated by the user - normal procedure"
(note 1)

On receipt of an ESTABLISH message, the IUT shall send ALLOCATION message containing the originating UP referenced in the UP_ID IE and an ESTABLISH ACK message.

LT1 sends an ALLOCATION COMPLETE message.

On receipt of a user release message (SIGNAL), the IUT shall send a DE-ALLOCATION message containing the originating UP referenced in the IE UP_ID IE and the allocated V5 TS referenced in the V5_TS_ID IE and a DISCONNECT message.

Postamble:
LT1 sends a DE-ALLOCATION and a DISCONNECT COMPLETE message.

TP42__SM_02 "ISDN-BA call establishment and release initiated by the user - normal procedure"
(note 2)

On receipt of a DSS1 SETUP message, the IUT shall send an ALLOCATION message containing the originating UP referenced in the UP_ID IE.

On receipt of an ALLOCATION COMPLETE message, the IUT shall respond to the DSS1 SETUP message.

On receipt of a DSS1 DISCONNECT message, the IUT shall send a DE-ALLOCATION message containing the originating UP referenced in the UP_ID IE and the allocated V5 TS referenced in the V5_TS_ID IE.

Postamble:
LT1 sends a DE-ALLOCATION COMPLETE message.

TP42__SM_03 "ISDN-PRA call establishment and release initiated by the user - normal procedure"
(note 3)

On receipt of a DSS1 SETUP message, the IUT shall send an ALLOCATION message containing the originating UP referenced in the UP_ID IE.

On receipt of an ALLOCATION COMPLETE message, the IUT shall respond to the DSS1 SETUP message.

On receipt of a DSS1 DISCONNECT message, the IUT shall send a DE-ALLOCATION message containing the originating UP referenced in the UP_ID IE and the allocated V5 TS referenced in the V5_TS_ID IE.

Postamble:
LT1 sends a DE-ALLOCATION COMPLETE message.

- TP42__SM_04 (note 4) "Multi slot connections"
Check that IUT is able to allocate and de-allocate multi slot connections.
- TP42__SM_05 (note 5) "Semi-permanent leased lines"
Check that IUT is able to allocate and de-allocate a V5 TS for semi-permanent leased lines.
- NOTE 1: This TP is only applicable if PICS item N2 (see ETS 300 347-2 [3]) is set to yes.
- NOTE 2: This TP is only applicable if PICS item N11 (see ETS 300 347-2 [3]) is set to yes.
- NOTE 3: This TP is only applicable if PICS item N12 (see ETS 300 347-2 [3]) is set to yes.
- NOTE 4: This TP is only applicable if PICS item N8 (see ETS 300 347-2 [3]) is set to yes.
- NOTE 5: This TP is only applicable if PICS item N32 (see ETS 300 347-2 [3]) is set to yes.

5.5.3 Valid behaviour tests (V5NWKLE/BCC/BV)

Refer to the ETS 300 347-1 [2], table 47 and annex E.

Initial state of the IUT: BCC_INIT
Preamble: CTRL_PSTN_LE10_20, CTRL_ISDNBA_LE10_20, CTRL_ISDNPRA_LE10_20
Postamble: CTRL_PSTN_LE20_10, CTRL_ISDNBA_LE20_10, CTRL_ISDNPRA_LE20_10

TP43__SM_01 (note 1) "ISDN call initiated by the user - simultaneous ISDN call set-up (from the same ISDN UP) and release"

On receipt of a DSS1 SETUP message, the IUT shall send an ALLOCATION message containing the originating UP referenced in the UP_ID IE.

On receipt of a second DSS1 SETUP message from the same UP but with different Call Reference, the IUT shall send a second ALLOCATION message containing the same UP_ID IE but different BCC_reference_number and V5_TS_ID IEs.

On receipt of the first ALLOCATION COMPLETE message, the IUT shall respond to the first DSS1 SETUP message.

On receipt of the second ALLOCATION COMPLETE message, the IUT shall respond to the second DSS1 SETUP message.

On receipt of two DSS1 DISCONNECT messages, the IUT shall send two DE-ALLOCATION messages containing the originating UP referenced in the UP_ID IE and the allocated V5 TS referenced in the V5_TS_ID IEs.

Postamble:
LT1 sends two DE-ALLOCATION COMPLETE messages.

- TP43__SM_02
(*
(note 1)
- "ISDN call establishment and release initiated by the network"
- On receipt of a terminating call attempt, the IUT shall send an ALLOCATION message containing the terminating UP referenced in the UP_ID IE.
- On receipt of an ALLOCATION COMPLETE message, the IUT shall send a DSS1 SETUP message.
- On receipt of a network release request and the DSS1 RELEASE message, the IUT shall send a DE-ALLOCATION message containing the terminating UP referenced in the UP_ID IE and the allocated V5 TS referenced in the V5_TS_ID IE.
- Postamble:
LT1 sends a DE-ALLOCATION COMPLETE message.
- TP43__SM_03
(note 1)
- "ISDN call initiated by the user - exceptional procedure"
- Preamble: BCC_ALLOC
- On receipt of an ALLOCATION REJECT message containing the reject_cause IE with cause type "AN blocked", the IUT shall send a second ALLOCATION message containing the same UP_ID IE but a different V5_TS_ID IE or release the call.
- TP43__SM_04
(*
(note 2)
- "PSTN call establishment and release initiated by the network"
- On receipt of terminating call attempt, the IUT shall send an ALLOCATION message containing the terminating UP referenced in the UP_ID IE.
- On receipt of an ALLOCATION COMPLETE message, the IUT shall send an ESTABLISH message.
- On receipt of a network release request, the IUT shall send a DE-ALLOCATION message containing the originating UP referenced in the IE UP_ID IE and the allocated V5 TS referenced in the V5_TS_ID IE and a DISCONNECT message.
- Postamble:
LT1 sends a DE-ALLOCATION and a DISCONNECT COMPLETE message.
- TP43__SM_05
(note 2)
- "PSTN call initiated by the user - exceptional procedure"
- On receipt of an ESTABLISH message, the IUT shall send an ALLOCATION message containing the originating UP referenced in the UP_ID IE and an ESTABLISH ACK message.
- On receipt of an ALLOCATION REJECT message containing the reject_cause IE with cause type "AN blocked", the IUT shall send a second ALLOCATION message containing the same UP_ID IE but a different V5_TS_ID IE or a DISCONNECT message.
- TP43__S2_06
(note 3)
- "De-Allocation-exceptional procedure"
- Preamble: BCC_DEALLOC
- On receipt of a DE-ALLOCATION REJECT message containing the reject_cause IE with cause type "unspecified", the IUT shall not repeat the DE-ALLOCATION message.
- During the postamble the IUT shall send a DE-ALLOCATION message.

- TP43__SM_07
(note 3) "AN internal failure, on-demand service affected"
- Preamble: BCC_CONN
- On receipt of an AN FAULT message, the IUT shall send an AN FAULT ACKNOWLEDGE and a DE-ALLOCATION message.
- Postamble:
LT1 sends a DE-ALLOCATION COMPLETE message.
- TP43__SM_08
(*
(note 4) "AN internal failure, semi-permanent leased line affected"
- Preamble:
Establishment of a semi-permanent leased line.
- On receipt of an AN FAULT message, the IUT shall send an AN FAULT ACKNOWLEDGE and a DE-ALLOCATION message.
- On receipt of a DE-ALLOCATION COMPLETE message the IUT shall send a new ALLOCATION message containing the same UP_ID IE but a different V5_TS_ID IE.
- TP43__SM_09
(note 3) "UP based Audit"
- Preamble: BCC_ALLOC
- On receipt of an ALLOCATION REJECT message containing the reject_cause IE "connection already present at the UP to a different V5 TS", the IUT shall send an AUDIT message containing only the UP_ID IE.
- On receipt of an AUDIT COMPLETE message containing the UP_ID IE and the V5_TS_ID IE (different to the V5_TS_ID IE in the original ALLOCATION message), the IUT shall send a DE-ALLOCATION message containing the same data.
- Postamble:
LT1 sends a DE-ALLOCATION COMPLETE message.
- TP43__SM_10
(note 3) "V5 TS based Audit"
- Preamble: BCC_ALLOC
- On receipt of an ALLOCATION REJECT message containing the reject_cause IE "connection already present at the V5 TS to a different UP", the IUT shall send an AUDIT message containing only the V5_TS_ID IE.
- On receipt of an AUDIT COMPLETE message containing a UP_ID IE and the V5_TS_ID IE (TS 1 on primary link), the IUT shall send a DE-ALLOCATION message containing the same data.
- Postamble:
LT1 sends a DE-ALLOCATION COMPLETE message.

TP43__S0_11 "Delayed ALLOCATION COMPLETE message"
(note 3)

Preamble:
BCC_ALLOC
On time out of timer TBCC1, the IUT shall repeat sending the ALLOCATION message.
On NBCC1+1 time outs of timer TBCC1, the IUT shall stop repeating the original message.

LT1 sends an ALLOCATION COMPLETE message.

During the postamble the IUT shall send a DE-ALLOCATION message.

TP43__S0_12 "Delayed ALLOCATION REJECT message"
(note 3)

Preamble:
BCC_ALLOC
On time out of timer TBCC1, the IUT shall repeat sending the ALLOCATION message.
On NBCC1+1 time outs of timer TBCC1, the IUT shall stop repeating the original message.

LT1 sends an ALLOCATION REJECT containing the reject_cause IE with cause type "AN blocked" message.

During the postamble the IUT shall not send a DE-ALLOCATION message.

TP43__S0_13 "Delayed DE-ALLOCATION COMPLETE message"
(note 3)

Preamble:
BCC_DEALLOC
On time out of timer TBCC3, the IUT shall repeat sending the DE-ALLOCATION message.
On NBCC3+1 time outs of timer TBCC3, the IUT shall stop repeating the original message.

LT1 sends a DE-ALLOCATION COMPLETE message.

During the postamble the IUT shall not send a DE-ALLOCATION message.

TP43__S0_14 "Delayed DE-ALLOCATION REJECT message"
(note 3)

Preamble:
BCC_DEALLOC
On time out of timer TBCC3, the IUT shall repeat sending the DE-ALLOCATION message.
On NBCC3+1 time outs of timer TBCC3, the IUT shall stop repeating the original message.

LT1 sends a DE-ALLOCATION REJECT message containing the reject_cause IE with cause type "unspecified".

During the postamble the IUT shall send a DE-ALLOCATION message.

TP43__SM_15 "Allocation Abort"
(note 3)

Preamble: BCC_ALLOC

On receipt of a PORT CONTROL message containing the control_function_element IE FE204 (block_cmd), the IUT shall send a DE-ALLOCATION message.

Postamble:
LT1 sends a DE-ALLOCATION COMPLETE message.

- TP43__S1_16 (note 3) "Error in ALLOCATION message"
Preamble: BCC_ALLOC
On receipt of a PROTOCOL ERROR message containing the protocol_error_cause IE "unrecognized IE", the IUT shall not repeat the ALLOCATION message.
- TP43__S3_17 (note 3) "Error in DE-ALLOCATION message"
Preamble: BCC_DEALLOC
On receipt of a PROTOCOL ERROR message containing the protocol_error_cause IE "unrecognized IE", the IUT shall not repeat the DE-ALLOCATION message.
During the postamble the IUT shall send a DE-ALLOCATION message.
- TP43__S4_18 (note 3) "Error in AUDIT message"
Preamble: BCC_AUDIT
On receipt of a PROTOCOL ERROR message containing the protocol_error_cause IE "unrecognized IE", the IUT shall not repeat the AUDIT message.
- NOTE 1: These TPs are only applicable if PICS items N11 or N12 (see ETS 300 347-2 [3]) is set to yes.
- NOTE 2: These TPs are only applicable if PICS item N2 (see ETS 300 347-2 [3]) is set to yes.
- NOTE 3: It is sufficient to perform these TPs for one of the main features N11, N12 or N2 (see ETS 300 347-2 [3]).
- NOTE 4: This TP is only applicable if PICS item N32 (see ETS 300 347-2 [3]) is set to yes.

5.5.4 Inopportune behaviour tests (V5NWKLE/BCC/BO)

Refer to the ETS 300 347-1 [2], subclause 17.5 and table 47.

It is sufficient to perform these TPs for one of the main features N11, N12 or N2 (see ETS 300 347-2 [3]).

- Initial state of the IUT: BCC_INIT
Preamble: CTRL_PSTN_LE10_20, CTRL_ISDNBA_LE10_20, CTRL_ISDNPRA_LE10_20
Postamble: CTRL_PSTN_LE20_10, CTRL_ISDNBA_LE20_10, CTRL_ISDNPRA_LE20_10
- TP44__S1_01 Preamble : BCC_ALLOC
On receipt of a DE-ALLOCATION COMPLETE message and time out of timer TBCC1, the IUT shall repeat the ALLOCATION message.
- TP44__S1_02 Preamble : BCC_ALLOC
On receipt of a DE-ALLOCATION REJECT message and time out of timer TBCC1, the IUT shall repeat the ALLOCATION message.
- TP44__S1_03 Preamble : BCC_ALLOC
On receipt of an AUDIT COMPLETE message and time out of timer TBCC1, the IUT shall repeat the ALLOCATION message.

- TP44__S1_04 Preamble : BCC_ALLOC
- On receipt of an AN FAULT message and time out of timer TBCC1, the IUT shall repeat the ALLOCATION message.
- TP44__S3_05 Preamble : BCC_DEALLOC
- On receipt of an ALLOCATION COMPLETE message and time out of timer TBCC3, the IUT shall repeat the DE-ALLOCATION message.
- TP44__S3_06 Preamble : BCC_DEALLOC
- On receipt of an ALLOCATION REJECT message and time out of timer TBCC3, the IUT shall repeat the DE-ALLOCATION message.
- TP44__S3_07 Preamble : BCC_DEALLOC
- On receipt of an AUDIT COMPLETE message and time out of timer TBCC3, the IUT shall repeat the DE-ALLOCATION message.
- TP44__S3_08 Preamble : BCC_DEALLOC
- On receipt of an AN FAULT message and time out of timer TBCC3, the IUT shall repeat the DE-ALLOCATION message.
- TP44__S4_09 Preamble : BCC_AUDIT
- On receipt of an ALLOCATION COMPLETE message and time out of timer TBCC4, the IUT shall repeat sending the AUDIT message.
- Postamble:
On receipt of an AUDIT COMPLETE message containing the UP_ID IE and the V5_TS_ID IE (different to the V5_TS_ID IE in the original ALLOCATION message), the IUT shall send a DE-ALLOCATION message containing the same data.
LT1 sends a DE-ALLOCATION COMPLETE message.
- TP44__S4_10 Preamble : BCC_AUDIT
- On receipt of an ALLOCATION REJECT message and time out of timer TBCC4, the IUT shall repeat sending the AUDIT message.
- Postamble:
On receipt of an AUDIT COMPLETE message containing the UP_ID IE and the V5_TS_ID IE (different to the V5_TS_ID IE in the original ALLOCATION message), the IUT shall send a DE-ALLOCATION message containing the same data.
LT1 sends a DE-ALLOCATION COMPLETE message.
- TP44__S4_11 Preamble : BCC_AUDIT
- On receipt of an DE-ALLOCATION COMPLETE message and time out of timer TBCC4, the IUT shall repeat sending the AUDIT message.
- Postamble:
On receipt of an AUDIT COMPLETE message containing the UP_ID IE and the V5_TS_ID IE (different to the V5_TS_ID IE in the original ALLOCATION message), the IUT shall send a DE-ALLOCATION message containing the same data.
LT1 sends a DE-ALLOCATION COMPLETE message.

TP44__S4_12 Preamble : BCC_AUDIT

On receipt of an DE-ALLOCATION REJECT message and time out of timer TBCC4, the IUT shall repeat sending the AUDIT message.

Postamble:
On receipt of an AUDIT COMPLETE message containing the UP_ID IE and the V5_TS_ID IE (different to the V5_TS_ID IE in the original ALLOCATION message), the IUT shall send a DE-ALLOCATION message containing the same data.
LT1 sends a DE-ALLOCATION COMPLETE message.

TP44__S4_13 Preamble : BCC_AUDIT

On receipt of an AN FAULT message and time out of timer TBCC4, the IUT shall repeat sending the AUDIT message.

Postamble:
On receipt of an AUDIT COMPLETE message containing the UP_ID IE and the V5_TS_ID IE (different to the V5_TS_ID IE in the original ALLOCATION message), the IUT shall send a DE-ALLOCATION message containing the same data.
LT1 sends a DE-ALLOCATION COMPLETE message.

5.5.5 Invalid behaviour tests (V5NWKLE/BCC/BI)

Refer to the ETS 300 347-1 [2], subclause 17.5 and table 47.

It is sufficient to perform these TPs for one of the main features N11, N12 or N2 (see ETS 300 347-2 [3]).

Initial state of the IUT: BCC_INIT
Preamble: CTRL_PSTN_LE10_20, CTRL_ISDNBA_LE10_20, CTRL_ISDNPRA_LE10_20
Postamble: CTRL_PSTN_LE20_10, CTRL_ISDNBA_LE20_10, CTRL_ISDNPRA_LE20_10

TP45__S0_01 Check that the IUT discards messages having less than 4 octets.

TP45__S1_02 (Protocol discriminator error)

Preamble: BCC_ALLOC

On receipt of an ALLOCATION COMPLETE message containing an unspecified protocol_discriminator IE, the IUT shall repeat the original ALLOCATION message.

TP45__S1_03 (Message type error)

Preamble: BCC_ALLOC

On receipt of a message containing an unspecified message_type IE, the IUT shall repeat the original ALLOCATION message.

TP45__S0_04 (Information element out of sequence)

Preamble: BCC_CONN

On receipt of an AN FAULT message containing unsorted IEs (multi_slot_map IE before UP_ID IE followed by V5_TS_ID IE), the IUT shall send an AN FAULT ACKNOWLEDGE message.

- TP45__S1_05 (Repeated mandatory information elements)
Preamble: BCC_ALLOC
On receipt of an ALLOCATION COMPLETE message containing two repeated message_type IE, the IUT shall repeat the original ALLOCATION message.
- TP45__S0_06 (Repeated optional information elements)
Preamble: BCC_CONN
On receipt of an AN FAULT message containing two repeated UP_ID IEs, the IUT shall send an AN FAULT ACKNOWLEDGE message.
- TP45__S1_07 (Mandatory information element missing)
Preamble: BCC_ALLOC
ON message containing the terminating UP referenced in the UP_ID IE.
On receipt of an ALLOCATION REJECT message containing no reject_cause IE, the IUT shall repeat the original ALLOCATION message.
- TP45__S1_08 (Unrecognized information element)
Preamble: BCC_ALLOC
On receipt of an ALLOCATION COMPLETE message containing an additional unspecified IE, the IUT shall not repeat the original ALLOCATION message.
- TP45__S1_09 (Content error of mandatory information element)
Preamble: BCC_ALLOC
On receipt of an ALLOCATION REJECT message containing an incorrect reject_cause IE, the IUT shall repeat the original ALLOCATION message.
- TP45__S1_10 (Content error of optional information element)
(note)
Preamble: BCC_CONN
On receipt of an AN FAULT message containing an incorrect ISDN_port_channel_ID IE, the IUT shall send an AN FAULT ACK message.
- TP45__S1_11 (Optional information element not allowed)
Preamble: BCC_ALLOC
On receipt of an ALLOCATION REJECT message containing an reject_cause IE, the IUT shall repeat the original ALLOCATION message.

NOTE: These TPs are only applicable if PICS items N11 or N12 (see ETS 300 347-2 [3]) is set to yes.

5.5.6 Timer expiry and counter mismatch tests (V5NWKLE/BCC/TI)

Refer to the ETS 300 347-1 [2], table 48.

It is sufficient to perform these TPs for one of the main features N11, N12 or N2 (see ETS 300 347-2 [3]).

Initial state of the IUT: BCC_INIT
Preamble: CTRL_PSTN_LE10_20, CTRL_ISDNBA_LE10_20, CTRL_ISDNPRA_LE10_20
Postamble: CTRL_PSTN_LE20_10, CTRL_ISDNBA_LE20_10, CTRL_ISDNPRA_LE20_10

TP46__S1_01 Preamble: BCC_ALLOC

On time out of timer TBCC1, the IUT shall repeat sending the ALLOCATION message.

On receipt of an ALLOCATION COMPLETE message after NBCC1 repetitions of the ALLOCATION message, the IUT shall stop repeating the original message.

During the postamble the IUT shall send a DE-ALLOCATION message.

TP46__S1_02 Preamble: BCC_ALLOC

On time out of timer TBCC1, the IUT shall repeat sending the ALLOCATION message.

On NBCC1+1 time outs of timer TBCC1, the IUT shall stop repeating the original message.

During the postamble the IUT shall not send a DE-ALLOCATION message.

TP46__S2_03 Preamble:
BCC_ALLOC
On receipt of a PORT CONTROL message containing the control_function_element IE FE204 (block_cmd), the IUT shall send a DE-ALLOCATION message.

On receipt of an ALLOCATION COMPLETE and an ALLOCATION REJECT message, the IUT shall not stop timer TBCC2.

On time out of timer TBCC2, the IUT shall repeat sending the DE-ALLOCATION message.

On receipt of a DE-ALLOCATION COMPLETE message after NBCC2 repetitions of the DE-ALLOCATION message, the IUT shall stop repeating the original message.

During the postamble the IUT shall not send a DE-ALLOCATION message.

TP46__S2_04 Preamble:
BCC_ALLOC
On receipt of a PORT CONTROL message containing the control_function_element IE FE204 (block_cmd), the IUT shall send a DE-ALLOCATION message.

On time out of timer TBCC2, the IUT shall repeat sending the DE-ALLOCATION message.

On NBCC2+1 time outs of timer TBCC2, the IUT shall stop repeating the original message.

During the postamble the IUT shall send a DE-ALLOCATION message.

TP46__S3_05 Preamble: BCC_DEALLOC

On time out of timer TBCC3, the IUT shall repeat sending the DE-ALLOCATION message.

On receipt of a DE-ALLOCATION COMPLETE message after NBCC3 repetitions of the DE-ALLOCATION message, the IUT shall stop repeating the original message.

During the postamble the IUT shall not send a DE-ALLOCATION message.

TP46__S3_06 Preamble: BCC_DEALLOC

On time out of timer TBCC3, the IUT shall repeat sending the DE-ALLOCATION message.

On NBCC3+1 time outs of timer TBCC3, the IUT shall stop repeating the original message.

During the postamble the IUT shall send a DE-ALLOCATION message.

TP46__S4_07 Preamble: BCC_AUDIT

On time out of timer TBCC4, the IUT shall repeat sending the AUDIT message.

On receipt of an AUDIT COMPLETE message containing the UP_ID IE and the V5_TS_ID IE (TS 2 on primary link) after NBCC4 repetitions of the AUDIT message, the IUT shall send a DE-ALLOCATION message containing the same data.

Postamble:
LT1 sends a DE-ALLOCATION COMPLETE message.

TP46__S4_08 Preamble: BCC_AUDIT

On time out of timer TBCC4, the IUT shall repeat sending the AUDIT message.

On NBCC4+1 time outs of timer TBCC3, the IUT shall stop repeating the original message.

5.6 Protection protocol

This test group is only applicable if PICS item N9 (see ETS 300 347-2 [3]) is set to yes.

If not stated otherwise, the PROTECT messages sent by the IUT or LT1 shall have the following contents:

- a) the SN IE shall be set according to the rules of ETS 300 347-1 [2], subclause 18.6.2. The initial value of the SN IE shall be 0 at the beginning of each TP;
- b) the logical_C-channel_ID IE shall point on logical C-channel 2 (protection group 2);
- c) the physical_C-channel_ID IE shall point on TS 15 on the secondary link. If not stated otherwise, the SWITCH-OVER REQ message shall not contain a physical_C-channel_ID IE;
- d) all LINK CONTROL messages shall contain the Layer 3 Address of the primary link.

Each PROTECT message sent by LT1 and IUT has to be broadcasted over TS 16 of the primary and secondary link with identical SN IEs. This has to be verified by LT1, but is not mentioned explicitly in the TPs.

Preambles given in a specific TP have to be applied after performing the global preamble, specific postambles have to be applied before performing the global postamble.

5.6.1 Basic interconnection tests (V5NWKLE/PROTECT/IT)

Initial state of the IUT: -
Preamble: -
Postamble: -

TP51__SM_01 Refer to TP11__SM_01, subclause 5.2.1

5.6.2 Capability tests (V5NWKLE/PROTECT/CA)

Refer to the ETS 300 347-1 [2], table 66.

Initial state of the IUT: PROTECT_INIT
Preamble: -
Postamble: -

TP52__S0_01 "Sequence number reset initiated by LT1- normal procedure"

On receipt of a RESET SN COM message, the IUT shall send a RESET SN ACK message.

On receipt of a second RESET SN COM message, the IUT shall not send a RESET SN ACK message.

TP52__S0_01 "Sequence number reset initiated by IUT- normal procedure"

On receipt of a SWITCH-OVER REQ message containing a SN IE = 5, the IUT shall send a RESET SN COM message.

On receipt of a RESET SN ACK message, the IUT shall not repeat the original message.

5.6.3 Valid behaviour tests (V5NWKLE/PROTECT/BV)

Refer to the ETS 300 347-1 [2], table 66.

Initial state of the IUT: PROTECT_INIT
Preamble: PROTECT_SOLEX_0
Postamble: PROTECT_SOLEX_0

TP53__SM_01 "Switch-Over requested by LT1 - normal procedure"

On receipt of a SWITCH-OVER REQ message, the IUT shall send a SWITCH-OVER COM message.

Postamble:
Sending of a SWITCH-OVER ACK message.
PROTECT_BACK_TO_INIT2.

TP53__SM_02 "Switch-Over requested by LT1 - normal procedure, repeated SWITCH-OVER REQ message"

On receipt of a SWITCH-OVER REQ message, the IUT shall send a SWITCH-OVER COM message.

On receipt of a second SWITCH-OVER REQ message, the IUT shall ignore the message.

Postamble:
Sending of a SWITCH-OVER ACK message.
PROTECT_BACK_TO_INIT2.

TP53__SM_03 "Switch-Over requested by IUT - normal procedure, failure of V5.2 primary link"

(*)

On receipt of the trigger event "failure of V5.2 link", indicating a failure of the primary link, the IUT shall send a SWITCH-OVER COM message containing the logical_C-channel_ID IE "1" and the physical_C-channel_ID IE "TS 16 of secondary link".

On receipt of a SWITCH-OVER ACK message, the IUT shall send a second SWITCH-OVER COM message containing the logical_C-channel_ID IE "2" and the physical_C-channel_ID IE "TS 15 of secondary link".

Postamble:

Sending of a SWITCH-OVER ACK message.

Disappearance of failure

PROTECT_BACK_TO_INIT1, PROTECT_BACK_TO_INIT2.

TP53__SM_04 "Switch-Over requested by IUT - normal procedure, absence of flags"

(*)

On receipt of the trigger event "absence of flags", indicating a failure of TS 16 of the primary link, the IUT shall send a SWITCH-OVER COM message containing the logical_C-channel_ID IE "1" and the physical_C-channel_ID IE "TS 16 of secondary link".

Postamble:

Sending of a SWITCH-OVER ACK message.

Disappearance of failure

PROTECT_BACK_TO_INIT1.

TP53__SM_05 "Switch-Over requested by IUT - normal procedure, data link failure"

(*)

On receipt of the trigger event "data link failure", indicating a failure of TS 16 of the primary link, the IUT shall send a SWITCH-OVER COM message containing the logical_C-channel_ID IE "1" and the physical_C-channel_ID IE "TS 16 of secondary link".

Postamble:

Sending of a SWITCH-OVER ACK message.

Disappearance of failure

PROTECT_BACK_TO_INIT1.

TP53__SM_06 "Switch-Over requested by IUT - normal procedure, blocking of primary link"

On receipt of a LINK CONTROL message containing the link_control_function IE FE304 (link_block_cmd), the IUT shall send a SWITCH-OVER COM message containing the logical_C-channel_ID IE "1" and the physical_C-channel_ID IE "TS 16 of secondary link".

On receipt of a SWITCH-OVER ACK message, the IUT shall send a second SWITCH-OVER COM message containing the logical_C-channel_ID IE "2" and the physical_C-channel_ID IE "TS 15 of secondary link".

Postamble:

Sending of a SWITCH-OVER ACK message.

LINK_LE10_20, PROTECT_BACK_TO_INIT1, PROTECT_BACK_TO_INIT2

- TP53__SM_07
(*)
- "OS-Switch-Over requested by IUT - normal procedure"
- Preamble:
Request for switch-over of logical C-channel "2" via Q_{Le}.
- On receipt of a MDU-PROT. (Os-switch-over com), the IUT shall send an OS-SWITCH-OVER COM message containing the logical_C-channel_ID IE "2" and the physical_C-channel_ID IE "TS 15 of secondary link".
- Postamble:
Request for switch-over of logical C-channel "2" via Q_{Le}.
On receipt of a MDU-PROT. (Os-switch-over com), the IUT shall send an OS-SWITCH-OVER COM message containing the logical_C-channel_ID IE "2" and the physical_C-channel_ID IE "TS 15 of primary link".
- TP53__SM_08
- "Switch-Over requested by LT1 - exceptional procedure, no standby C-channel available"
- Preamble:
LINK_LE20_10 for secondary link.
- On receipt of a SWITCH-OVER REQ message, the IUT shall send a SWITCH-OVER REJ message containing the reject_cause IE "no standby C-channel available".
- Postamble: LINK_LE10_20 for secondary link.
- TP53__S1_09
- "Switch-Over requested by LT1 - exceptional procedure, LT1 resets SN, TSO5 not running"
- Preamble:
On receipt of a SWITCH-OVER REQ message, the IUT shall send a SWITCH-OVER COM message.
- On receipt of a RESET SN COM message the IUT shall send a RESET SN ACK and shall not repeat the SWITCH-OVER COM message.
- TP53__S1_10
- "Switch-Over requested by LT1 - exceptional procedure, LT1 resets SN, TSO5 running"
- Preamble:
On receipt of a RESET SN COM message the IUT shall send a RESET SN ACK.
On receipt of a SWITCH-OVER REQ message, the IUT shall send a SWITCH-OVER COM message.
- On receipt of a RESET SN COM message the IUT shall not send a RESET SN ACK and repeat the SWITCH-OVER COM message with SN IE =1 (after time out of timer TSO1).
- Postamble:
Sending of a SWITCH-OVER ACK message.
PROTECT_BACK_TO_INIT2

- TP53__S1_11 "Switch-Over requested by LT1 - exceptional procedure, LT1 sends RESET SN ACK"
- Preamble:
On receipt of a SWITCH-OVER REQ message, the IUT shall send a SWITCH-OVER COM message.
- On receipt of a RESET SN ACK message, the IUT shall repeat the SWITCH-OVER COM message with SN IE =1 (after time out of timer TSO1).
- Postamble:
Sending of a SWITCH-OVER ACK message.
PROTECT_BACK_TO_INIT2
- TP53__S0_12 "Switch-Over requested by LT1 - exceptional procedure, timer TSO4 running"
- Preamble:
On receipt of a SWITCH-OVER REQ message containing a SN IE = 5, the IUT shall send a RESET SN COM message.
- On receipt of a SWITCH-OVER REQ message, the IUT shall ignore the message.
- Postamble:
Sending of a RESET SN ACK message.
- TP53__S1_13 "Switch-Over requested by IUT - exceptional procedure, LT1 rejects switch-over"
- Preamble:
On receipt of a LINK CONTROL message containing the link_control_function IE FE304 (link_block_cmd), the IUT shall send a SWITCH-OVER COM message containing the logical_C-channel_ID IE "1" and the physical_C-channel_ID IE "TS 16 of secondary link".
- On receipt of a SWITCH-OVER REJ message containing the rejection_cause IE "target physical C-channel not available", the IUT shall not repeat the original message.
- Postamble: STARTUP_LE
- TP53__SM_14 "Switch-Over requested by IUT - exceptional procedure, TSO4 running"
- Preamble:
On receipt of a SWITCH-OVER REQ message containing a SN IE = 5, the IUT shall send a RESET SN COM message.
- On receipt of a LINK CONTROL message containing the link_control_function IE FE304 (link_block_cmd), no PROTECT message shall appear on the V5.2 interface.
- On receipt of a RESET SN ACK message, the IUT shall send a SWITCH-OVER COM message containing the logical_C-channel_ID IE "1" and the physical_C-channel_ID IE "TS 16 of secondary link".
- On receipt of a SWITCH-OVER ACK message, the IUT shall send a second SWITCH-OVER COM message containing the logical_C-channel_ID IE "2" and the physical_C-channel_ID IE "TS 15 of secondary link".
- Postamble:
Sending of a SWITCH-OVER ACK message.
LINK_LE10_20, PROTECT_BACK_TO_INIT1, PROTECT_BACK_TO_INIT2

- TP53__SM_15
(*) "OS-Switch-Over requested by IUT - exceptional procedure, TSO4 running"
- Preamble:
On receipt of a SWITCH-OVER REQ message containing a SN IE = 5, the IUT shall send a RESET SN COM message.
Request for switch-over of logical C-channel "2" via Q_{Le}.
- On receipt of a MDU-PROT. (Os-switch-over com), no PROTECT message shall appear on the V5.2 interface.
- On receipt of a RESET SN ACK message, the IUT shall send an OS-SWITCH-OVER COM message containing the logical_C-channel_ID IE "2" and the physical_C-channel_ID IE "TS 15 of secondary link".
- Postamble:
Request for switch-over of logical C-channel "2" via Q_{Le}.
On receipt of a MDU-PROT. (Os-switch-over com), the IUT shall send an OS-SWITCH-OVER COM message containing the logical_C-channel_ID IE "2" and the physical_C-channel_ID IE "TS 15 of primary link".
- TP53__SM_16 "Unexpected switch-over acknowledgement, TSO4 not running"
- On receipt of a SWITCH-OVER ACK message, the IUT shall send a SWITCH-OVER COM message containing the physical_C-channel_ID IE "TS 15 of primary link".
- Postamble:
Sending of a SWITCH-OVER ACK message
- TP53__S0_17 "Unexpected switch-over acknowledgement, TSO4 running"
- Preamble:
On receipt of a SWITCH-OVER REQ message containing a SN IE = 5, the IUT shall send a RESET SN COM message.
- On receipt of a SWITCH-OVER ACK message, the IUT shall ignore the message.
- Postamble:
Sending of a RESET SN ACK message
- TP53__SM_18
(*) "Checking upper boundary of SN"
- On receipt of a SWITCH-OVER REQ message containing the SN IE = 4, the IUT shall send a SWITCH-OVER COM message.
- Postamble:
Sending of a SWITCH-OVER ACK message.
PROTECT_BACK_TO_INIT2.
- TP53__S0_19 On receipt of a SWITCH-OVER REJ message, the IUT shall ignore the message.

5.6.4 Invalid behaviour tests (V5NWKLE/PROTECT/BI)

Refer to the ETS 300 347-1 [2], subclause 18.6.6.

Initial state of the IUT: PROTECT_INIT
Preamble: PROTECT_SOLEX_0
Postamble: PROTECT_SOLEX_0

TP55__S0_01 Check that the IUT discards messages having less than 4 octets.

TP55__S0_02 (Protocol discriminator error)

On receipt of a RESET SN COM message containing an unspecified protocol_discriminator IE, the IUT shall ignore the message (send no RESET SN ACK message).

TP55__S0_03 (Message type error)

On receipt of a message containing an unspecified message_type IE, the IUT shall ignore the message.

TP55__S0_04 (Repeated mandatory information elements)

On receipt of a RESET SN ACK message containing a repeated message_type IE, the IUT shall ignore the message (send no RESET SN ACK message).

TP55__S0_05 (Mandatory information element missing)

On receipt of a SWITCH-OVER REQ message containing no logical_C-channel_ID IE, the IUT shall ignore the message (send no SWITCH-OVER COM message)

TP55__S0_06 (Unrecognized information element)

On receipt of a RESET SN COM message containing an additional unspecified IE, the IUT shall send a RESET SN ACK message.

TP55__S0_07 (Content error of mandatory information element)

On receipt of a RESET SN COM message containing an incorrect sequence_number IE, the IUT shall ignore the message (send no RESET SN ACK message)

5.6.5 Timer expiry and counter mismatch tests (V5NWKLE/PROTECT/TI)

Refer to the ETS 300 347-1 [2], table 66.

Initial state of the IUT: PROTECT_INIT
Preamble: PROTECT_SOLEX_0
Postamble: PROTECT_SOLEX_0

TP56__S0_01 Preamble:

On receipt of a SWITCH-OVER REQ message containing a SN IE = 5, the IUT shall send a RESET SN COM message.

On time out of timer TSO4, the IUT shall repeat sending the RESET SN COM message.

On receipt of a RESET SN ACK message after NSO4 repetitions of the RESET SN COM message, the IUT shall stop repeating the original message.

- TP56__S0_02 Preamble:
On receipt of a SWITCH-OVER REQ message containing a SN IE = 5, the IUT shall send a RESET SN COM message.
- On time out of timer TSO4, the IUT shall repeat sending the RESET SN COM message.
- On NSO4+1 time outs of timer TSO4, the IUT shall stop repeating the original message.
- TP56__S1_03 Preamble:
On receipt of a SWITCH-OVER REQ message, the IUT shall send a SWITCH-OVER COM message.
- On time out of timer TSO1, the IUT shall repeat sending the SWITCH-OVER COM message.
- On receipt of a SWITCH-OVER ACK message after NSO1 repetitions of the SWITCH-OVER COM message, the IUT shall stop repeating the original message.
- Postamble: PROTECT_BACK_TO_INIT2
- TP56__S1_04 Preamble:
On receipt of a SWITCH-OVER REQ message, the IUT shall send a SWITCH-OVER COM message.
- On time out of timer TSO1, the IUT shall repeat sending the SWITCH-OVER COM message.
- On NSO1+1 time outs of timer TSO1, the IUT shall stop repeating the original message.
- TP56__S1_05 Preamble:
(*) Request for switch-over of logical C-channel "2" via Q_{Le}.
- On receipt of a MDU-PROT. (Os-switch-over com), the IUT shall send an OS-SWITCH-OVER COM message containing the logical_C-channel_ID IE "2" and the physical_C-channel_ID IE "TS 15 of secondary link".
- On time out of timer TSO2, the IUT shall repeat sending the OS-SWITCH-OVER COM message.
- On receipt of a SWITCH-OVER ACK message after NSO2 repetitions of the OS-SWITCH-OVER COM message, the IUT shall stop repeating the original message.
- Postamble:
Request for switch-over of logical C-channel "2" via Q_{Le}.
On receipt of a MDU-PROT. (Os-switch-over com), the IUT shall send an OS-SWITCH-OVER COM message containing the logical_C-channel_ID IE "2" and the physical_C-channel_ID IE "TS 15 of primary link".

TP56__S1_06
(*)

Preamble:
Request for switch-over of logical C-channel "2" via Q_{Le}.

On receipt of a MDU-PROT. (Os-switch-over com), the IUT shall send an OS-SWITCH-OVER COM message containing the logical_C-channel_ID IE "2" and the physical_C-channel_ID IE "TS 15 of secondary link".

On time out of timer TSO2, the IUT shall repeat sending the OS-SWITCH-OVER COM message.

On NSO2+1 time outs of timer TSO2, the IUT shall stop repeating the original message.

TP56__S1_07

Preamble:
On receipt of a LINK CONTROL message containing the link_control_function IE FE304 (link_block_cmd), the IUT shall send a SWITCH-OVER COM message containing the logical_C-channel_ID IE "1" and the physical_C-channel_ID IE "TS 16 of secondary link".

On receipt of a SWITCH-OVER ACK message containing the SN IE = 6, the IUT shall send a RESET SN COM message.

Postamble:
On receipt of a SWITCH-OVER ACK message, the IUT shall send a second SWITCH-OVER COM message containing the logical_C-channel_ID IE "2" and the physical_C-channel_ID IE "TS 15 of secondary link".
Sending of a SWITCH-OVER ACK message.
LINK_LE10_20, PROTECT_BACK_TO_INIT1, PROTECT_BACK_TO_INIT2

Annex A (informative): Bibliography

- ETS 300 406: "Methods for Testing and Specification (MTS); Protocol and profile conformance testing specifications; Standardization methodology".

History

| Document history | | | |
|------------------|----------------|--------|--------------------------|
| March 1995 | Public Enquiry | PE 81: | 1995-03-27 to 1995-08-18 |
| December 1995 | Vote | V 94: | 1995-12-27 to 1996-02-16 |
| February 1996 | First Edition | | |
| | | | |
| | | | |