



**E**UROPEAN  
**T**ELECOMMUNICATION  
**S**TANDARD

**FINAL DRAFT**  
pr **ETS 300 347-3**

January 1999

**Second Edition**

---

Source: SPS

Reference: RE/SPS-09056-3

ICS: 33.020

**Key words:** V interface, V5 interface, PSTN, ISDN, AN, TSS&TP, testing, layer 3, LE

**V interfaces at the digital Local Exchange (LE);  
V5.2 interface for the support of Access Network (AN);  
Part 3: Test Suite Structure and Test Purposes (TSS&TP)  
specification for the network layer (AN side)**

**ETSI**

European Telecommunications Standards Institute

**ETSI Secretariat**

**Postal address:** F-06921 Sophia Antipolis CEDEX - FRANCE

**Office address:** 650 Route des Lucioles - Sophia Antipolis - Valbonne - FRANCE

**Internet:** secretariat@etsi.fr - <http://www.etsi.org>

Tel.: +33 4 92 94 42 00 - Fax: +33 4 93 65 47 16

---

**Copyright Notification:** No part may be reproduced except as authorized by written permission. The copyright and the foregoing restriction extend to reproduction in all media.

© European Telecommunications Standards Institute 1999. All rights reserved.



## Contents

Foreword		7
1	Scope	9
2	Normative references	9
3	Definitions and abbreviations	9
3.1	Definitions	9
3.2	Abbreviations	10
4	Test Suite Structure (TSS)	11
4.1	Overview	11
4.2	Test groups	12
4.2.1	Protocol groups	13
4.2.1.1	Control protocol	13
4.2.1.2	Public Switched Telephone Network (PSTN) protocol	13
4.2.1.3	Link control protocol	13
4.2.1.4	Bearer Channel Connection (BCC) protocol	13
4.2.1.5	Protection protocol	14
4.2.2	Main test groups	14
4.2.2.1	Basic Interconnection tests (IT)	14
4.2.2.2	Capability tests (CA)	14
4.2.2.3	Valid Behaviour tests (BV)	14
4.2.2.4	Inopportune Behaviour tests (BO)	14
4.2.2.5	Invalid Behaviour tests (BI)	14
4.2.2.6	Timer expiry and counter mismatch tests (TI)	14
4.2.2.6.1	Timers and counters of the Control protocol	14
4.2.2.6.2	Timers and counters of the PSTN protocol	14
4.2.2.6.3	Timers and counters of the Link control protocol	15
4.2.2.6.4	Timers and counters of the BCC protocol	15
4.2.2.6.5	Timers and counters of the Protection protocol	15
4.2.2.6.6	Timers and counters of the AN system management	15
4.3	Test step structure	15
4.3.1	State transitions	15
4.3.1.1	Start-up of V5.2 interface	16
4.3.1.2	Common control protocol (system management)	18
4.3.1.3	Control protocol (PSTN port FSM)	18
4.3.1.4	Control protocol (ISDN-BA port FSM)	18
4.3.1.5	Control protocol (ISDN-PRA port FSM)	18
4.3.1.6	PSTN protocol	18
4.3.1.7	Link control protocol	19
4.3.1.8	BCC protocol	19
4.3.1.9	Protection protocol	19
4.3.2	Preconditions	19
4.3.3	Preambles	19
4.3.4	Postambles	20
4.3.5	Status verification	20
4.3.5.1	PSTN protocol	20
4.3.5.2	Link control FSM	20
4.3.6	Common test steps	20
4.4	Defaults	20

4.5	Abstract Service Primitives (ASPs) and Protocol Data Units (PDUs) .....	20
4.5.1	ASPs .....	20
4.5.2	PDUs .....	20
4.5.2.1	Common control protocol .....	20
4.5.2.2	Port control protocol .....	20
4.5.2.3	PSTN protocol .....	20
4.5.2.4	Link control protocol .....	20
4.5.2.5	BCC protocol .....	21
4.5.2.6	Protection protocol .....	21
4.5.3	Information elements .....	21
4.5.3.1	Variable length information elements .....	21
4.5.3.1.1	Control protocol .....	21
4.5.3.1.2	PSTN protocol .....	21
4.5.3.1.3	Link control protocol .....	21
4.5.3.1.4	BCC protocol .....	21
4.5.3.1.5	Protection protocol .....	21
4.5.3.2	Single octet information elements .....	22
4.5.3.2.1	Control protocol .....	22
4.5.3.2.2	PSTN protocol .....	22
4.5.3.2.3	Link control protocol .....	22
4.5.3.2.4	BCC protocol .....	22
4.5.3.2.5	Protection protocol .....	22
4.6	Timers and counters of the Abstract Test Suite (ATS) .....	22
5	Test Purposes (TPs) .....	23
5.1	Introduction .....	23
5.1.1	Test purpose naming convention .....	23
5.1.2	Source of test purpose definition .....	24
5.1.3	Test strategy .....	24
5.1.3.1	Common control protocol .....	24
5.1.3.2	Port control protocol .....	24
5.1.3.3	PSTN protocol .....	24
5.1.3.4	Link control protocol .....	25
5.1.3.5	BCC protocol .....	25
5.1.3.6	Protection protocol .....	26
5.1.4	Requirements not covered by test purposes .....	26
5.1.5	Initial states .....	26
5.1.6	Test and data configuration requirements .....	27
5.2	Control protocol .....	27
5.2.1	Basic interconnection tests (V5NWKAN/CTRL/IT) .....	27
5.2.2	Capability tests (V5NWKAN/CTRL/CA) .....	27
5.2.3	Valid behaviour tests (V5NWKAN/CTRL/BV) .....	27
5.2.3.1	V5NWKAN/CTRL/BV/COM .....	27
5.2.3.2	V5NWKAN/CTRL/BV/PORT .....	28
5.2.3.2.1	V5NWKAN/CTRL/BV/PORT/TRANS .....	28
5.2.3.2.2	V5NWKAN/CTRL/BV/PORT/PSTN .....	28
5.2.3.2.3	V5NWKAN/CTRL/BV/PORT/ISDNBA .....	28
5.2.3.2.4	... V5NWKAN/CTRL/BV/PORT/ISDNPRA28 .....	28
5.2.4	Inopportune behaviour tests (V5NWKAN/CTRL/BO) .....	29
5.2.4.1	V5NWKAN/CTRL/BO/COM .....	29
5.2.4.2	V5NWKAN/CTRL/BO/PORT .....	29
5.2.4.2.1	V5NWKAN/CTRL/BO/PORT/TRANS .....	29
5.2.4.2.2	V5NWKAN/CTRL/BO/PORT/PSTN .....	29
5.2.4.2.3	V5NWKAN/CTRL/BO/PORT/ISDNBA .....	30
5.2.4.2.4	... V5NWKAN/CTRL/BO/PORT/ISDNPRA30 .....	30
5.2.5	Invalid behaviour tests (V5NWKAN/CTRL/BI) .....	30
5.2.6	Timer expiry and counter mismatch tests (V5NWKAN/CTRL/TI) .....	30
5.3	PSTN protocol .....	30
5.4	Link control protocol .....	30
5.4.1	Basic interconnection tests (V5NWKAN/LINK/IT) .....	30
5.4.2	Capability tests (V5NWKAN/LINK/CA) .....	30

5.4.3	Valid behaviour tests (V5NWKAN/LINK/BV).....	31
5.4.3.1	V5NWKAN/LINK/BV/TRANS.....	31
5.4.3.2	V5NWKAN/LINK/BV/LINK.....	31
5.4.4	Inopportune behaviour tests (V5NWKAN/LINK/BO).....	43
5.4.4.1	V5NWKAN/LINK/BO/TRANS.....	43
5.4.4.2	V5NWKAN/LINK/BO/LINK.....	43
5.4.5	Invalid behaviour tests (V5NWKAN/LINK/BI).....	46
5.4.5.1	V5NWKAN/LINK/BI/TRANS.....	46
5.4.6	Timer expiry and counter mismatch tests (V5NWKAN/LINK/TI).....	47
5.4.6.1	V5NWKAN/LINK/TI/TRANS.....	47
5.5	BCC protocol.....	47
5.5.1	Basic interconnection tests (V5NWKAN/BCC/IT).....	48
5.5.2	Capability tests (V5NWKAN/BCC/CA).....	48
5.5.3	Valid behaviour tests (V5NWKAN/BCC/BV).....	49
5.5.4	Inopportune behaviour tests (V5NWKAN/BCC/BO).....	52
5.5.5	Invalid behaviour tests (V5NWKAN/BCC/BI).....	53
5.5.6	Timer expiry and counter mismatch tests (V5NWKAN/BCC/TI).....	55
5.6	Protection protocol.....	55
5.6.1	Basic interconnection tests (V5NWKAN/PROTECT/IT).....	55
5.6.2	Capability tests (V5NWKAN/PROTECT/CA).....	56
5.6.3	Valid behaviour tests (V5NWKAN/PROTECT/BV).....	56
5.6.4	Inopportune behaviour tests (V5NWKAN/PROTECT/BO).....	61
5.6.5	Invalid behaviour tests (V5NWKAN/PROTECT/BI).....	61
5.6.6	Timer expiry and counter mismatch tests (V5NWKAN/PROTECT/TI).....	63
Annex A (informative):	Bibliography.....	65
History.....		66

Blank page

## Foreword

This final draft European Telecommunication Standard (ETS) has been produced by the Signalling Protocols and Switching (SPS) Technical Committee of the European Telecommunications Standards Institute (ETSI), and is now submitted for the Voting phase of the ETSI standards approval procedure.

This ETS is part 3 of a multi-part standard covering the V5.2 interface as described below:

- Part 1: "V5.2 interface specification";
- Part 2: "Protocol Implementation Conformance Statement (PICS) proforma";
- Part 3: "Test Suite Structure and Test Purposes (TSS&TP) specification for the network layer (AN side)";**
- Part 4: "Abstract Test Suite (ATS) and partial Protocol Implementation eXtra Information for Testing (PIXIT) proforma specification for the network layer (AN side)";
- Part 5: "Test Suite Structure and Test Purposes (TSS&TP) specification for the network layer (LE side)";
- Part 6: "Abstract Test Suite (ATS) and partial Protocol Implementation eXtra Information for Testing (PIXIT) proforma specification for the network layer (LE side)";
- Part 7: "Test Suite Structure and Test Purposes (TSS&TP) specification for the data link layer";
- Part 8: "Abstract Test Suite (ATS) and partial Protocol Implementation eXtra Information for Testing (PIXIT) proforma specification for the data link layer";
- Part 9: "Test specification for the physical layer".

<b>Proposed transposition dates</b>	
Date of latest announcement of this ETS (doa):	3 months after ETSI publication
Date of latest publication of new National Standard or endorsement of this ETS (dop/e):	6 months after doa
Date of withdrawal of any conflicting National Standard (dow):	6 months after doa

Blank page



## 1 Scope

This third part of ETS 300 347 contains the Test Suite Structure and Test Purposes (TSS&TP) for the network layer and parts of the system management of the Access Network (AN) side of a V5.2 interface.

The objective of this ETS is to provide conformance tests giving a high probability of inter-operability of an AN and a Local Exchange (LE) from different manufacturers over the V5.2 interface. This ETS covers only the procedures described in ETS 300 347-1 [2].

ISO/IEC 9646-1 [4] and ISO/IEC 9646-2 [5] are used as the basis for the test methodology.

This ETS needs to be read in conjunction with ETS 300 324-3 [1]. The two documents share a common format and clauses within ETS 300 324-3 [1] are directly referenced.

Annex A lists the bibliography.

## 2 Normative references

This ETS incorporates by dated and undated reference, provisions from other publications. These normative references are cited at the appropriate places in the text and the publications are listed hereafter. For dated references, subsequent amendments to or revisions of any of these publications apply to this ETS only when incorporated in it by amendment or revision. For undated references the latest edition of the publication referred to applies.

- [1] ETS 300 324-3 (1999) including amendment A1: "V interfaces at the digital Local Exchange (LE); V5.1 interface for the support of Access Network (AN); Part 3: Test Suite Structure and Test Purposes (TSS&TP) specification for the network layer (AN side)".
- [2] ETS 300 347-1 (1994) including amendment A1: "V interfaces at the digital Local Exchange (LE); V5.2 interface for the support of Access Network (AN); Part 1: V5.2 interface specification".
- [3] ETS 300 347-2 (1994): "V interfaces at the digital Local Exchange (LE); V5.2 interface for the support of Access Network (AN); Part 2: Protocol Implementation Conformance Statement (PICS) proforma".
- [4] ISO/IEC 9646-1 (1995): "Information technology - Open systems interconnection - Conformance testing methodology and framework - Part 1: General concepts".
- [5] ISO/IEC 9646-2 (1995): "Information technology - Open systems interconnection - Conformance testing methodology and framework - Part 2: Abstract test suite specification".

## 3 Definitions and abbreviations

### 3.1 Definitions

For the purposes of this ETS, the following definitions apply, in addition to those given in ETS 300 324-3 [1] and ETS 300 347-1 [2]:

**incorrect information element:** A specified information element carrying information element types which are not defined in ETS 300 347-1 [2].

**specified information element:** Information element identifier as defined in ETS 300 347-1 [2].

**unspecified information element:** Information element identifier which is not defined in ETS 300 347-1 [2].

### 3.2 Abbreviations

For the purposes of this ETS, the following abbreviations apply:

AIS	Alarm Indication Signal
AN	Access Network
ASP	Abstract Service Primitive
ATS	Abstract Test Suite
BCC	Bearer Channel Connection
BI	Invalid Behaviour
BO	Inopportune Behaviour
BV	Valid Behaviour
CA	Capability
COM	Common control protocol
CTRL	Control
FE	Function Element
FSM	Finite State Machine
ID	Identifier
IE	Information Element
ISDN	Integrated Services Digital Network
ISDN-BA	ISDN Basic Access
ISDN-PRA	ISDN Primary Rate Access
IT	Basic Interconnection
IUT	Implementation Under Test
L3addr	Layer 3 address
LE	Local Exchange
LT1	Lower Tester 1
MDU	Management Data Unit
MPH	Management Physical layer
NWK	Network layer
PDU	Protocol Data Unit
PICS	Protocol Implementation Conformance Statement
PSTN	Public Switched Telephone Network
RAI	Remote Alarm Indication
REQ	Request
SN	Sequence Number
SUT	System Under Test
TE	Terminal Equipment (ISDN or PSTN)
TI	Timer
TP	Test Purpose
TS	Time Slot
TSS	Test Suite Structure
UP	User Port

## 4 Test Suite Structure (TSS)

### 4.1 Overview

Figure 1 shows the structure of the V5.2 NetWork layer (NWK) test suite.

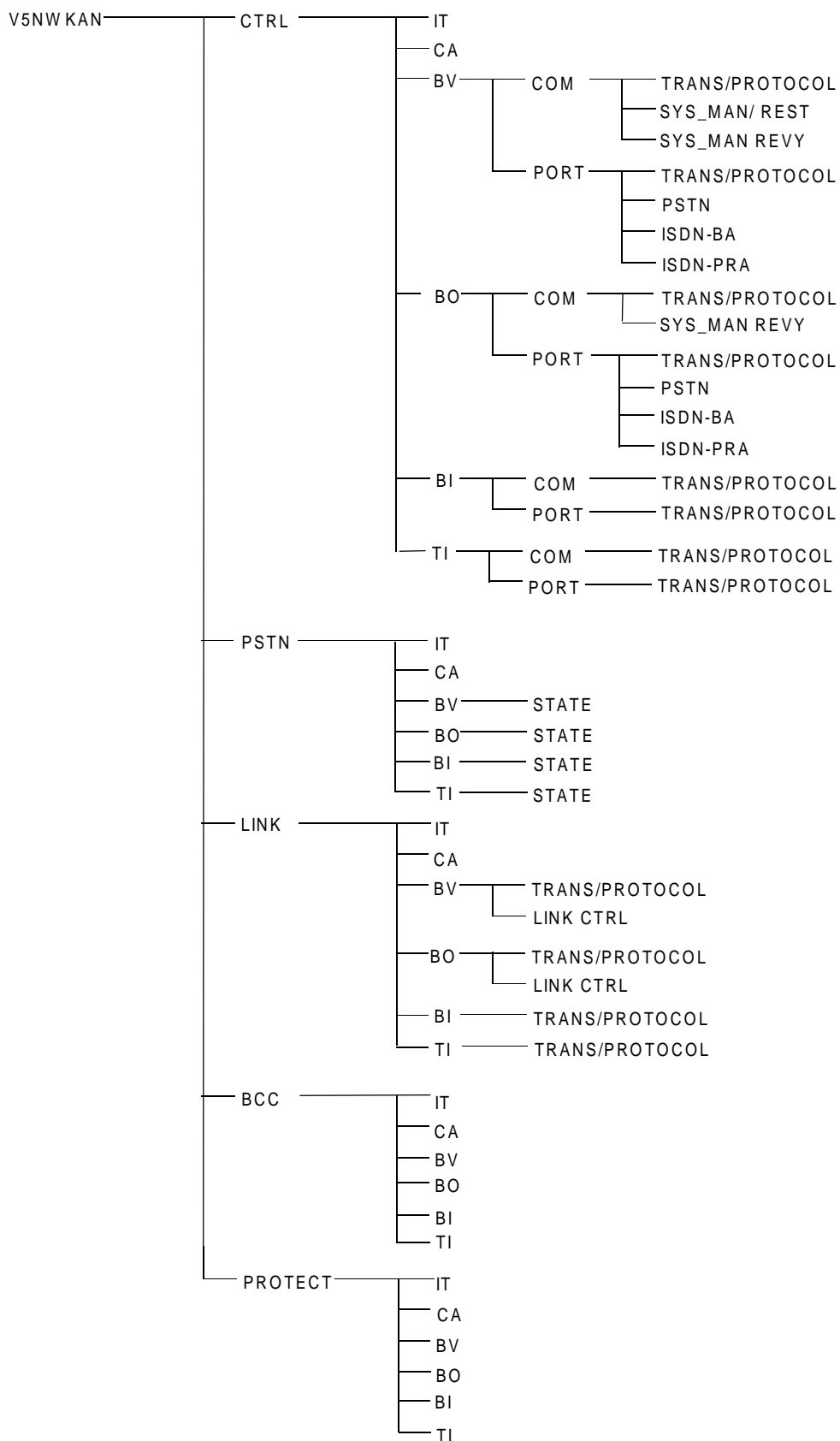

Figure 1: NWK AN test suite structure

## 4.2 Test groups

Figure 2 gives an overview of the various protocol entities of a V5.2 interface. Table 1 maps each protocol entity on tested protocol groups.

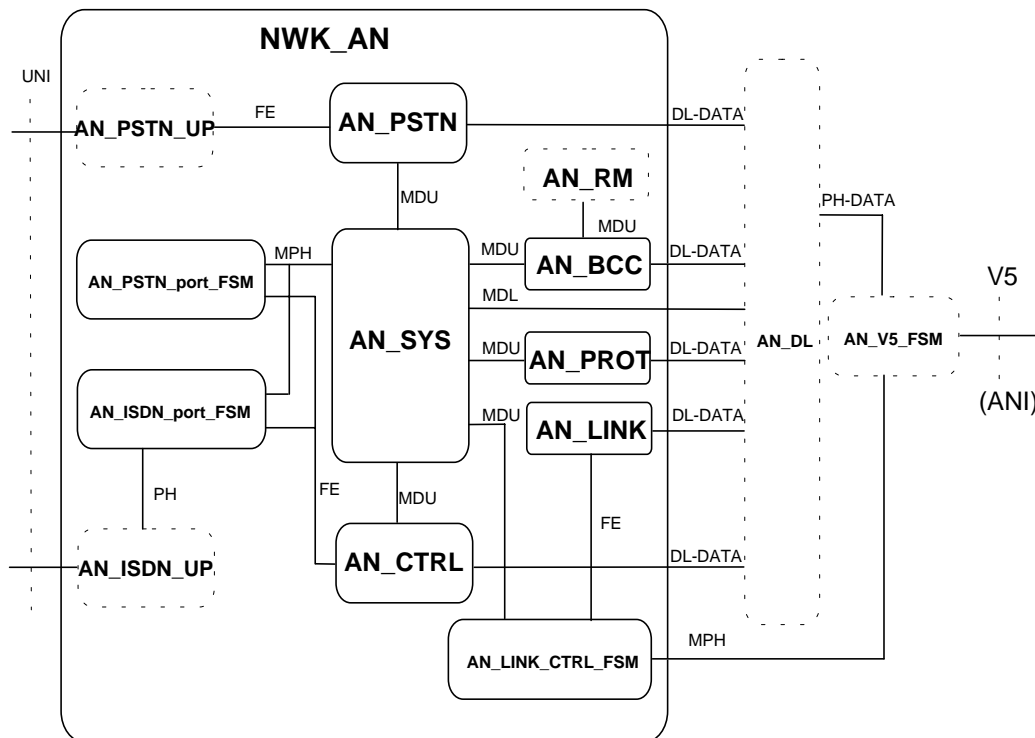

Figure 2: NWK AN - protocol entity overview

Table 1: Names used in figure 2 that correspond to ETS 300 347-1 [2]

Network layer protocol entity	Protocol entity defined in ETS 300 347-1 [2]	Protocol group reference
AN_PSTN_UP	AN_PSTN_user_port	4.2.1.1
AN_PSTN_port_FSM	AN_PSTN_user_port_FSM	4.2.1.1
AN_ISDN_port_FSM	AN_ISDN_BA_user_port_FSM AN_ISDN_PRA_user_port_FSM	4.2.1.1
AN_ISDN_UP	AN_ISDN_BA_user_port AN_ISDN_PRA_user_port	4.2.1.1
AN_CTRL	AN_control_protocol	4.2.1.1
AN_SYS	AN_system_management	4.2.1.1
AN_PSTN	AN_PSTN_protocol	4.2.1.2
AN_LINK	AN_link_control_protocol	4.2.1.3
AN_LINK_CTRL_FSM	AN_link_control_FSM	4.2.1.3
AN_RM	AN_resource_manager	4.2.1.4
AN_BCC	AN_BCC_protocol	4.2.1.4
AN_PROT	AN_protection_protocol	4.2.1.5

#### 4.2.1 Protocol groups

##### 4.2.1.1 Control protocol

The contents of this subclause are identical to subclause 4.2.1.1 of ETS 300 324-3 [1] with the following additions for the ISDN-PRA user port Finite State Machine (FSM).

Depending on provisioning the following configuration is tested:

###### **AN\_ISDN-PRA\_user\_port:**

The blocking, blocking request and co-ordinated unblocking procedures of the AN\_ISDN-PRA\_user\_port\_FSM are verified in the test group V5NWKAN/CTRL/BV/PORT/ISDNPRA and V5NWKAN/CTRL/BO/PORT/ISDNPRA.

##### 4.2.1.2 Public Switched Telephone Network (PSTN) protocol

The contents of this subclause are identical to subclause 4.2.1.2 of ETS 300 324-3 [1].

##### 4.2.1.3 Link control protocol

All tests in the Link control protocol (V5NWKAN/LINK) test group are intended to verify as thoroughly as possible the various procedures of the AN\_link\_control\_protocol entity.

Depending on provisioning the following configurations are covered:

###### **AN\_link\_control\_protocol:**

The normal and exceptional procedures of the AN\_link\_control\_protocol are verified in the test groups V5NWKAN/LINK/BV/TRANS, V5NWKAN/LINK/BO/TRANS and V5NWKAN/LINK/TI/TRANS.

The error handling procedures are verified in the test group V5NWKAN/LINK/BI/TRANS.

###### **AN\_link\_control\_FSM:**

The link blocking, link blocking request, co-ordinated link unblocking and link identification procedures of the AN\_link\_control\_FSM are verified in the test groups V5NWKAN/LINK/BV/LINK and V5NWKAN/LINK/BO/LINK.

##### 4.2.1.4 Bearer Channel Connection (BCC) protocol

All tests in the BCC protocol (V5NWKAN/BCC) test group are intended to verify as thoroughly as possible the various procedures of the AN\_BCC protocol entity.

The following BCC procedures are covered:

- normal and exceptional bearer channel allocation procedure;
- normal and exceptional bearer channel de-allocation procedure;
- audit procedure;
- AN internal failure notification procedure;
- error handling procedures.

#### 4.2.1.5 Protection protocol

All tests in the Protection protocol (V5NWKAN/PROTECT) test group are intended to verify as thoroughly as possible the various procedures of the AN Protection protocol entity.

The following Protection protocol procedures are covered:

- transmission of Protection protocol messages;
- normal and exceptional sequence number reset procedure;
- normal and exceptional standard protection switch-over procedure initiated by AN side;
- normal and exceptional dedicated protection switch-over procedure initiated by OS AN;
- normal and exceptional switch-over procedure requested by AN side;
- error handling procedures.

#### 4.2.2 Main test groups

##### 4.2.2.1 Basic Interconnection tests (IT)

The contents of this subclause are identical to subclause 4.2.2.1 of ETS 300 324-3 [1].

##### 4.2.2.2 Capability tests (CA)

The contents of this subclause are identical to subclause 4.2.2.2 of ETS 300 324-3 [1].

##### 4.2.2.3 Valid Behaviour tests (BV)

The contents of this subclause are identical to subclause 4.2.2.3 of ETS 300 324-3 [1].

##### 4.2.2.4 Inopportune Behaviour tests (BO)

The contents of this subclause are identical to subclause 4.2.2.4 of ETS 300 324-3 [1].

##### 4.2.2.5 Invalid Behaviour tests (BI)

The contents of this subclause are identical to subclause 4.2.2.5 of ETS 300 324-3 [1].

##### 4.2.2.6 Timer expiry and counter mismatch tests (TI)

The contents of this subclause are identical to subclause 4.2.2.6 of ETS 300 324-3 [1].

###### 4.2.2.6.1 Timers and counters of the Control protocol

The contents of this subclause are identical to subclause 4.2.2.6.1 of ETS 300 324-3 [1] the addition for the accelerated alignment procedure. Additional timers are given in ETS 300 347-1 [2], annex C, table C.1.

- TU1 MDU-CTRL(UNBLOCK ALL RELEVANT PORTS ACCEPTED) to all PSTN and ISDN user port FSMs
- TU2 MDU-CTRL(UNBLOCK ALL RELEVANT PORTS REQUEST) to all PSTN and ISDN user port FSMs

###### 4.2.2.6.2 Timers and counters of the PSTN protocol

The contents of this subclause are identical to subclause 4.2.2.6.2 of ETS 300 324-3 [1].

#### 4.2.2.6.3 Timers and counters of the Link control protocol

Refer to ETS 300 347-1 [2], table 23.

LCTO1 LINK CONTROL message sent

#### 4.2.2.6.4 Timers and counters of the BCC protocol

Refer to ETS 300 347-1 [2], table 46.

TBCC5 AN fault sent

#### 4.2.2.6.5 Timers and counters of the Protection protocol

Refer to ETS 300 347-1 [2], table 64.

TSO3 SWITCH-OVER REQ sent  
TSO4 RESET SN COM sent  
TSO5 RESET SN COM received

Refer to ETS 300 347-1 [2], subclause 18.6.2.

VP(S) Send State Variable  
VP(R) Receive State Variable

#### 4.2.2.6.6 Timers and counters of the AN system management

The contents of this subclause are identical to subclause 4.2.2.6.3 of ETS 300 324-3 [1].

### 4.3 Test step structure

General dynamic behaviours are described in test steps which can be called from all test cases within the Abstract Test Suite (ATS):

state transitions	(refer to subclause 4.3.1);
preconditions	(refer to subclause 4.3.2);
preambles	(refer to subclause 4.3.3);
postambles	(refer to subclause 4.3.4);
status verification	(refer to subclause 4.3.5);
common test steps	(refer to subclause 4.3.6).

#### 4.3.1 State transitions

The following subclauses identify the test steps used in the ATS. In general, each test step represents a state transition. For example in the PSTN protocol, PSTN\_AN1\_2 is the test step which brings the AN PSTN protocol FSM from PSTN\_path\_state AN1 to PSTN\_path\_state AN2. The state transitions are declared in the parenthesis (originating state - destination state) which follow the test step names.

Six groups of state transitions are defined:

<b>STARTUP</b>	start up the V5 interface and put the Implementation Under Test (IUT) into the initial state as defined in subclause 5.1.5.
<b>CTRL</b>	state transitions used to preamble and postamble the Control protocol before a test purpose can be performed.
<b>PSTN</b>	state transitions used to preamble and postamble the PSTN protocol before a test purpose can be performed.
<b>LINK</b>	state transitions used to preamble and postamble the Link control protocol before a test purpose can be performed.

**BCC** state transitions used to preamble and postamble the BCC protocol before a test purpose can be performed.

**PROTECT** state transitions used to preamble and postamble the Protection protocol before a test purpose can be performed.

To test the V5.2 interface certain sequences (i.e. preamble) shall be executed to reach the state which is the subject for the test purposes.

#### 4.3.1.1 Start-up of V5.2 interface

The start-up procedure for a V5.2 interface depends on the provisioned data configuration. Therefore, the three PICS items N11, N12, M2 and N9 (see subclause 6.6.1 of ETS 300 347-2 [3]) are used to define the implemented configuration of the IUT.

NOTE 1: ETS 300 347-2 [3] requires that at least one of the three PICS items N11, N12 and M2 shall be set.

NOTE 2: PICS item N9 defines the configuration of the IUT with multiple or one single 2 048 kbit/s digital links as a V5.2 interface. A single 2 048 kbit/s digital link have no protection function implemented.



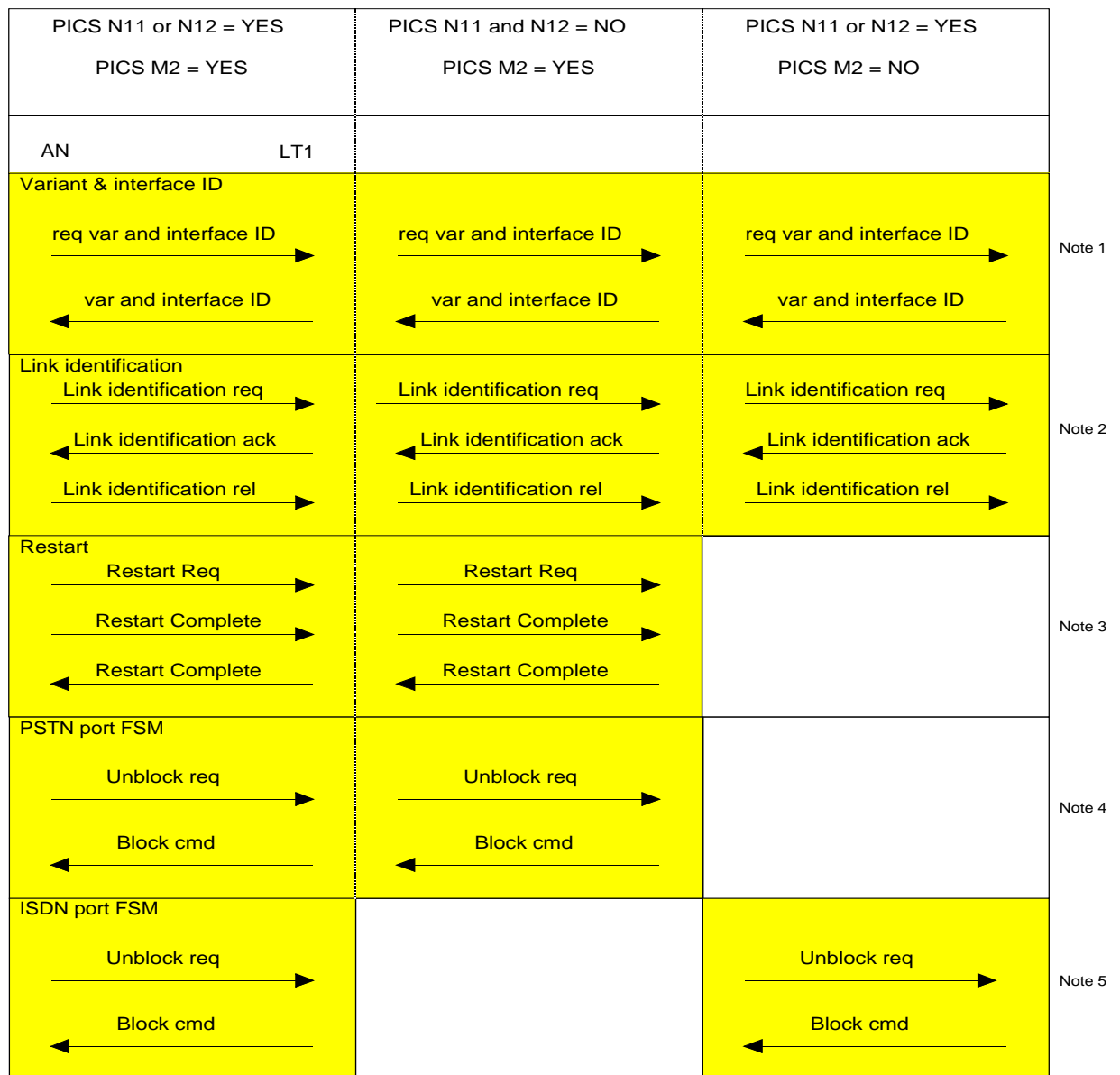

- NOTE 1: A test of the IUT's capability of receiving a request for the variant and interface ID is covered in subclause 5.2.3.1.
- NOTE 2: The number of appearances of this part of the system start-up procedure depends on the configuration of the IUT. A test of the IUT's capability of receiving a link identification request is covered in subclause 5.4.3.2.
- NOTE 3: LT1 shall wait for the receipt of restart complete from the IUT before sending restart complete.
- NOTE 4: To reach the initial state of the IUT PSTN user port FSM as defined in subclause 5.1.5, the IUT's unblocking request is rejected by LT1. Before rejecting the unblock request, it shall be verified that the IUT PSTN protocol has entered the PSTN\_path\_state AN6 (Port Blocked).
- NOTE 5: If the PICS items N11 and N12 are set to YES, this part of the system start-up procedure appears twice, once for the ISDN-BA port and once for the ISDN-PRA port. To reach the initial state of the IUT ISDN-BA user port FSM and/or the ISDN-PRA user port FSM as defined in subclause 5.1.5, the IUT's unblocking request is rejected by LT1.

Figure 3: STARTUP\_AN flow diagram

PICS item description:

N11: ISDN-BA ports supported;  
N12: ISDN-PRA ports supported;  
M2: PSTN ports supported;  
N9: Multiple link V5.2 interface;  
R5.4: Accelerated port state alignment.

NOTE 3: One port of each supported type shall be provisioned in a way that the IUT tries to enter the operational state for these ports after system start-up (see subclause 5.1.6).

NOTE 4: At START\_UP the LT1 will reject all request on accelerated port state alignment by respond with the control message UBA-rejected (see subclause 5.1.6).

Depending on the setting of the PICS items, the start-up procedure is described in figure 3. This flow diagram describes the test step called STARTUP\_AN.

#### **4.3.1.2 Common control protocol (system management)**

The contents of this subclause are identical to subclause 4.3.1.2 of ETS 300 324-3 [1].

#### **4.3.1.3 Control protocol (PSTN port FSM)**

The contents of this subclause are identical to subclause 4.3.1.3 of ETS 300 324-3 [1].

#### **4.3.1.4 Control protocol (ISDN-BA port FSM)**

The contents of this subclause are identical to subclause 4.3.1.4 of ETS 300 324-3 [1].

#### **4.3.1.5 Control protocol (ISDN-PRA port FSM)**

Refer to ETS 300 347-1 [2], table 8.

#### **CTRL\_ISDNPRA\_AN10\_10**

On receipt of a local unblock\_req (MPH-UBR) the IUT shall send a message containing the control\_function\_element IE FE202 (unblock\_req).

On receipt of a PORT CONTROL message containing the control\_function\_element IE FE203 (block\_cmd) the IUT ISDN-PRA user port FSM shall re-enter state AN1.0.

#### **CTRL\_ISDNPRA\_AN20\_10**

On receipt of a PORT CONTROL message containing the control\_function\_element IE FE203 (block\_cmd) the IUT shall enter state AN1.0.

#### **CTRL\_ISDNPRA\_AN10\_20**

On receipt of a PORT CONTROL message containing the control\_function\_element IE FE201 (unblock\_req) the IUT shall respond with the PORT CONTROL message containing the control\_function\_element IE FE202 (unblock\_ack) and then enter state AN2.0.

#### **4.3.1.6 PSTN protocol**

The contents of this subclause are identical to subclause 4.3.1.5 of ETS 300 324-3 [1].

#### 4.3.1.7 Link control protocol

##### **LINK\_AN20\_10**

On receipt of a LINK CONTROL message containing the link\_control\_function IE FE303 (link\_block\_cmd) the IUT link control FSM shall enter state AN1.0.

NOTE: The blocking of a V5.2 link results in a protection switching (if possible) of all C-paths carried by that link.

##### **LINK\_AN10\_20**

On receipt of a LINK CONTROL message containing the link\_control\_function IE FE301 (link\_unblock\_req) the IUT shall respond with the LINK CONTROL message containing the link\_control\_function IE FE302 (link\_unblock\_ack) and then enter state AN2.0.

#### 4.3.1.8 BCC protocol

##### **BCC\_CONN**

On receipt of an ALLOCATION message, the IUT shall send an ALLOCATION COMPLETE message.

##### **BCC\_REL**

On receipt of a DE-ALLOCATION message, the IUT shall send a DE-ALLOCATION COMPLETE message.

##### **BCC\_FAULT**

On receipt of an ALLOCATION message, the IUT shall send an ALLOCATION COMPLETE message. On detection of "AN internal failure" of the allocated connection, the IUT shall send an AN FAULT message containing the UP\_ID IE, the ISDN\_port\_channel\_ID (only for ISDN application) and the V5\_TS\_ID IE.

#### 4.3.1.9 Protection protocol

##### **PROTECT\_SOANx\_0**

On receipt of a RESET SN COM message, the IUT shall send a RESET SN ACK message (IUT protection FSM enters state SOAN0).  
Complete this teststep by waiting for the expiration of timer TSO5.

##### **PROTECT\_BACK\_TO\_INIT1**

On receipt of a SWITCH-OVER COM message containing the logical\_C-channel\_ID IE "logical C-channel 1" and the physical\_C-channel\_ID IE "TS 16 of primary link", the IUT shall send a SWITCH-OVER ACK message containing the same data.

##### **PROTECT\_BACK\_TO\_INIT2**

On receipt of a SWITCH-OVER COM message containing the logical\_C-channel\_ID IE "logical C-channel 2" and the physical\_C-channel\_ID IE "TS 15 of primary link", the IUT shall send a SWITCH-OVER ACK message containing the same data.

##### **PROTECT\_BACK\_TO\_INIT3**

On receipt of a SWITCH-OVER COM message containing the logical\_C-channel\_ID IE "logical C-channel 3" and the physical\_C-channel\_ID IE "TS 31 of primary link", the IUT shall send a SWITCH-OVER ACK message containing the same data.

#### 4.3.2 Preconditions

The contents of this subclause are identical to subclause 4.3.2 of ETS 300 324-3 [1].

#### 4.3.3 Preambles

The preamble test step group contains the test steps needed for initialization of the IUT before testing the particular test purpose. All combinations of the test steps defined in subclause 4.3.1.2 to subclause 4.3.1.9 can be used to create preambles. Each preamble shall start from the IUT initial state as defined in subclause 5.1.5.

#### 4.3.4 Postambles

After each test case the IUT shall be brought back to the initial state as defined in subclause 5.1.5. All combinations of the test steps defined in subclauses 4.3.1.2 to 4.3.1.9 can be used to create postambles.

#### 4.3.5 Status verification

##### 4.3.5.1 PSTN protocol

The contents of this subclause are identical to subclause 4.3.5 of ETS 300 324-3 [1].

##### 4.3.5.2 Link control FSM

###### **LINK\_CHECK\_ID** (Path active)

On receipt of a message containing the link\_control\_function IE FE-IDReq (link\_identification\_req) the IUT shall send a message containing the link\_control\_function IE FE-IDAck (link\_identification\_ack) and frames with  $S_{a7}$  bit set to zero.

On receipt of a message containing the link\_control\_function IE FE-IDRel (link\_identification\_rel) the IUT shall send frames with  $S_{a7}$  bit set to one.

#### 4.3.6 Common test steps

The contents of this subclause are identical to subclause 4.3.6 of ETS 300 324-3 [1].

#### 4.4 Defaults

The contents of this subclause are identical to subclause 4.4 of ETS 300 324-3 [1].

#### 4.5 Abstract Service Primitives (ASPs) and Protocol Data Units (PDUs)

##### 4.5.1 ASPs

The contents of this subclause are identical to subclause 4.5.1 of ETS 300 324-3 [1].

##### 4.5.2 PDUs

###### 4.5.2.1 Common control protocol

The contents of this subclause are identical to subclause 4.3.4 of ETS 300 324-3 [1].

###### 4.5.2.2 Port control protocol

The contents of this subclause are identical to subclause 4.3.4 of ETS 300 324-3 [1].

###### 4.5.2.3 PSTN protocol

The contents of this subclause are identical to subclause 4.3.4 of ETS 300 324-3 [1].

###### 4.5.2.4 Link control protocol

link\_ctrl  
link\_ctrl\_ack

#### 4.5.2.5 BCC protocol

bcc\_allocation  
bcc\_allocation\_complete  
bcc\_allocation\_reject  
bcc\_deallocation  
bcc\_deallocation\_complete  
bcc\_deallocation\_reject  
bcc\_audit  
bcc\_audit\_complete  
bcc\_an\_fault  
bcc\_an\_fault\_ack  
bcc\_protocol\_error

#### 4.5.2.6 Protection protocol

protect\_switch\_over\_req  
protect\_switch\_over\_com  
protect\_os\_switch\_over\_com  
protect\_switch\_over\_ack  
protect\_switch\_over\_reject  
protect\_protocol\_error  
protect\_reset\_sn\_com  
protect\_reset\_sn\_ack

#### 4.5.3 Information elements

##### 4.5.3.1 Variable length information elements

###### 4.5.3.1.1 Control protocol

The contents of this subclause are identical to subclause 4.5.3.1.1 of ETS 300 324-3 [1].

###### 4.5.3.1.2 PSTN protocol

The contents of this subclause are identical to subclause 4.5.3.1.2 of ETS 300 324-3 [1].

###### 4.5.3.1.3 Link control protocol

link\_control\_function

###### 4.5.3.1.4 BCC protocol

bcc\_user\_port\_ident  
bcc\_ISDN\_port\_channel\_ident  
bcc\_V5-time\_slot\_ident  
bcc\_multi\_slot\_map  
bcc\_reject\_cause  
bcc\_protocol\_error\_cause  
bcc\_connection\_incomplete

###### 4.5.3.1.5 Protection protocol

protect\_sequence\_number  
protect\_logical\_c\_channel\_ident  
protect\_physical\_c\_channel\_ident  
protect\_rejection\_cause  
protect\_protocol\_error\_cause

#### 4.5.3.2 Single octet information elements

##### 4.5.3.2.1 Control protocol

The contents of this subclause are identical to subclause 4.5.3.2.1 of ETS 300 324-3 [1].

##### 4.5.3.2.2 PSTN protocol

The contents of this subclause are identical to subclause 4.5.3.2.2 of ETS 300 324-3 [1].

##### 4.5.3.2.3 Link control protocol

There are no single octet information elements defined within the Link control protocol.

##### 4.5.3.2.4 BCC protocol

There are no single octet information elements defined within the BCC protocol.

##### 4.5.3.2.5 Protection protocol

There are no single octet information elements defined within the Protection protocol.

#### 4.6 Timers and counters of the Abstract Test Suite (ATS)

This subclause describes the timers and counters used in the ATS. The **min** and **max** indications define if the timer value represents the minimum or maximum limit of a timer. The timer values contain some additional tolerances for delays caused by test simulators. Therefore, a bigger timer tolerance is given than defined in ETS 300 347-1 [2]:

Minimum value of ATS timer = ETS timer - ETS tolerance;  
Maximum value of ATS timer = ETS timer + 2 x ETS tolerance.

The repetition of messages by the IUT shall be tested in the following way: The message has to be repeated within the time period  $T_{\min} < T < T_{\max}$ . This testing procedure applies to the tests in the TI-test group only.

Timers used in the ATS are given in *Timer Declarations* part of the ATS.

Table 3 gives the ATS counters which are used in addition to those defined in subclause 4.6 of ETS 300 324-3 [1].

**Table 3: Protocol counter values and references to ETS 300 347-1 [2]**

ATS counter name	ATS counter value	Explanation	Reference to ETS 300 347-1 [2]
NLCO1	1	Allowed number of repetitions of the LINK CONTROL message	clause 16, table 23
NBCC5	1	Allowed number of repetitions of the AN FAULT message	clause 17, table 46
NSO3	1	Allowed number of repetitions of the SWITCH-OVER REQ message	clause 18, table 64
NSO4	1	Allowed number of repetitions of the RESET SN COM message	clause 18, table 64

## 5 Test Purposes (TPs)

### 5.1 Introduction

The contents of this subclause are identical to subclause 5.1 of ETS 300 324-3 [1] and also valid for the V5.2 interface.

#### 5.1.1 Test purpose naming convention

The identifier of a test purpose is built according to the scheme described in table 4.

**Table 4: Test purpose identifier naming convention scheme**

Identifier:	TP<t><c><g1><g2><tpt><s><ss><nn>																		
<t>	=	type of protocol:	<table> <tr><td>1</td><td>Control protocol</td></tr> <tr><td>2</td><td>PSTN protocol</td></tr> <tr><td>3</td><td>Link control protocol</td></tr> <tr><td>4</td><td>BCC protocol</td></tr> <tr><td>5</td><td>Protection protocol</td></tr> </table>	1	Control protocol	2	PSTN protocol	3	Link control protocol	4	BCC protocol	5	Protection protocol						
1	Control protocol																		
2	PSTN protocol																		
3	Link control protocol																		
4	BCC protocol																		
5	Protection protocol																		
<c>	=	category:	<table> <tr><td>1</td><td>IT, Basic Interconnection Tests</td></tr> <tr><td>2</td><td>CA, Capability Tests</td></tr> <tr><td>3</td><td>BV, Valid Behaviour Tests</td></tr> <tr><td>4</td><td>BO, Inopportune Behaviour Tests</td></tr> <tr><td>5</td><td>BI, Invalid Behaviour Tests</td></tr> <tr><td>6</td><td>TI, Timer Expiry and Counter Mismatch</td></tr> </table>	1	IT, Basic Interconnection Tests	2	CA, Capability Tests	3	BV, Valid Behaviour Tests	4	BO, Inopportune Behaviour Tests	5	BI, Invalid Behaviour Tests	6	TI, Timer Expiry and Counter Mismatch				
1	IT, Basic Interconnection Tests																		
2	CA, Capability Tests																		
3	BV, Valid Behaviour Tests																		
4	BO, Inopportune Behaviour Tests																		
5	BI, Invalid Behaviour Tests																		
6	TI, Timer Expiry and Counter Mismatch																		
<g1>	=	group level 1:	<table> <tr><td>1</td><td>Common control</td></tr> <tr><td>2</td><td>Port control</td></tr> <tr><td>–</td><td>(underscore) Not relevant</td></tr> </table>	1	Common control	2	Port control	–	(underscore) Not relevant										
1	Common control																		
2	Port control																		
–	(underscore) Not relevant																		
<g2>	=	group level 2:	<table> <tr><td>1</td><td>Transport</td></tr> <tr><td>2</td><td>System management procedure Restart</td></tr> <tr><td>3</td><td>System management procedure Re-provisioning &amp; Verification</td></tr> <tr><td>4</td><td>PSTN</td></tr> <tr><td>5</td><td>ISDN-BA</td></tr> <tr><td>6</td><td>ISDN-PRA</td></tr> <tr><td>7</td><td>Link control</td></tr> <tr><td>–</td><td>(underscore) Not relevant</td></tr> </table>	1	Transport	2	System management procedure Restart	3	System management procedure Re-provisioning & Verification	4	PSTN	5	ISDN-BA	6	ISDN-PRA	7	Link control	–	(underscore) Not relevant
1	Transport																		
2	System management procedure Restart																		
3	System management procedure Re-provisioning & Verification																		
4	PSTN																		
5	ISDN-BA																		
6	ISDN-PRA																		
7	Link control																		
–	(underscore) Not relevant																		
<tpt>	=	test purpose type:	<table> <tr><td>S</td><td>Single</td></tr> <tr><td>C</td><td>Combined</td></tr> </table>	S	Single	C	Combined												
S	Single																		
C	Combined																		
<s>	=	state	<table> <tr><td>(0-9)</td><td></td></tr> <tr><td>M</td><td>Multiple state transition</td></tr> <tr><td>–</td><td>(underscore) Not relevant</td></tr> </table>	(0-9)		M	Multiple state transition	–	(underscore) Not relevant										
(0-9)																			
M	Multiple state transition																		
–	(underscore) Not relevant																		
<ss>	=	substate	<table> <tr><td>(0-9)</td><td></td></tr> <tr><td>–</td><td>(underscore) Not relevant</td></tr> </table>	(0-9)		–	(underscore) Not relevant												
(0-9)																			
–	(underscore) Not relevant																		
<nn>	=	sequential number	(01-99)																

### 5.1.2 Source of test purpose definition

The TPs were developed based on ETS 300 347-1 [2], clauses 14 to 18 and annexes A to E.

### 5.1.3 Test strategy

#### 5.1.3.1 Common control protocol

To achieve a maximum of test coverage with an appropriate number of TPs the following selection criteria have been applied:

- a) the Common control protocol and the System management procedures are not tested on a per-state basis. The TPs step through the FSMs by testing the procedures and supervising the behaviour of the IUT at the interface;
- b) the error handling procedures of the Common control protocol are not exhaustively tested. Not all possible combinations of protocol errors in all protocol states are covered. The TPs cover only examples for each error handling procedure in state AN1 of the Common control protocol;
- c) for several TPs some activities by the testing person are required (invoking of certain procedures by the System Under Test (SUT)). These TPs are marked with (\*).

#### 5.1.3.2 Port control protocol

To achieve a maximum of test coverage with an appropriate number of TPs the following selection criteria have been applied:

- a) the Port control protocol, the ISDN-BA user port FSM, the ISDN-PRA user port FSM and the PSTN user port FSM are not tested on a per-state basis. The TPs step through the FSMs by testing the procedures and supervising the behaviour of the IUT at the interface;
- b) the error handling procedures of the Port control protocol are not exhaustively tested. Not all possible combinations of protocol errors in all protocol states are covered. The TPs cover only examples for each error handling procedure in state AN1 of the Port control protocol. During these tests the PSTN and ISDN-BA user port FSMs stay in state AN1.0;
- c) for several TPs some activities by the testing person are required (invoking of certain procedures by the SUT). These TPs are marked with (\*);
- d) no differentiation between AN1.01 and AN1.02 for ISDN-PRA. Both substrates are handled as AN1.0;
- e) the accelerated alignment procedure is not generally tested in all port related TPs. In case of a request message from the IUT the LT1 will respond with reject that force the IUT to proceed with the existing procedure.

#### 5.1.3.3 PSTN protocol

To achieve a maximum of test coverage with an appropriate number of TPs the following selection criteria have been applied:

- a) only the first up to the third values of the PSTN sequence number variables S(S), S(A), S(R), M(S), M(R) is covered;
- b) the error handling procedures of the PSTN protocol are not exhaustively tested. Not all possible combinations of protocol errors in all protocol states are covered. The TPs cover only examples for each error handling procedure in PSTN\_path\_state AN1. To easily perform some of the abstract test cases, some procedures are tested in PSTN\_path\_state AN5;
- c) the procedure for unexpected events of the PSTN protocol is exhaustively tested (all unexpected events in all PSTN\_path\_states are covered);



- d) for several TPs some activities by the testing person are required (invoking of certain procedures by the SUT). These TPs are marked with (\*).

#### **5.1.3.4 Link control protocol**

To achieve a maximum of test coverage with an appropriate number of TPs the following selection criteria have been applied:

- a) the Link control protocol and the Link Control FSM are not tested on a per-state basis. The TPs step through the FSMs by testing the procedures and supervising the behaviour of the IUT at the V5.2 interface;
- b) the error handling procedures of the Link control protocol are not exhaustively tested. Not all possible combinations of protocol errors in all protocol states are covered. The test purposes cover only examples for each error handling procedure in state AN1 of the Link control protocol. During these tests the Link control FSM stays in state AN2.0;
- c) for several TPs some activities by the testing person are required (invoking of certain procedures by the SUT). These TPs are marked with (\*);
- d) if PICS item N9 (see ETS 300 347-2 [3]) is set to yes (multiple 2 048 kbit/s interface), there may be an impact of link control procedures on protection switching. This impact is tested in subclause 5.6. Refer to subclause 5.1.6 for the configuration which is required for the link control tests;
- e) if PICS item N9 (see ETS 300 347-2 [3]) is set to no (single 2 048 kbit/s interface), persistent link failures are not tested in the link control test group;

NOTE: In this case, persistent link failures generate data link failures which are covered by ETS 300 347-7.

- f) if PICS item N9 (see ETS 300 347-2 [3]) is set to no, only the remote link blocking procedure is tested because blocking of a V5.2 link in a single link configuration may take the complete interface out of service;
- g) after each TP the remote link identification procedure is applied to check that the link is still operational.

#### **5.1.3.5 BCC protocol**

To achieve a maximum of test coverage with an appropriate number of TPs the following selection criteria have been applied:

- a) the BCC protocol is not tested on a per-state basis. The TPs step through the FSM by testing the procedures and supervising the behaviour of the IUT at the V5.2 interface;
- b) the BCC protocol entity in AN is tested without any call control related procedures.
- c) the error handling procedures of the BCC protocol are not exhaustively tested. Not all possible combinations of protocol errors in all protocol states are covered;
- d) for several TPs some activities by the testing person are required (invoking of certain procedures by the SUT). These TPs are marked with (\*).

### 5.1.3.6 Protection protocol

To achieve a maximum of test coverage with an appropriate number of TPs the following selection criteria have been applied:

- a) the Protection protocol is not tested on a per-state basis. The TPs step through the FSM by testing the procedures and supervising the behaviour of the IUT at the V5.2 interface;
- b) the error handling procedures of the Protection protocol are not exhaustively tested. Not all possible combinations of protocol errors in all protocol states are covered. The test purposes cover only examples for each error handling procedure in state SOAN0 of the Protection protocol;
- c) for several TPs some activities by the testing person are required (invoking of certain procedures by the SUT). These TPs are marked with (\*);
- d) there are three monitor functions defined which can create trigger events for an autonomous protection switch-over:
  - layer 1 monitoring (trigger event: failure of a V5.2 link; refer to subclause 18.1.5.1 of ETS 300 347-1 [2]);
  - flag monitoring (trigger event: absence of flags, refer to subclause 18.1.5.2 of ETS 300 347-1 [2]);
  - data link monitoring (trigger event: data link failure, refer to subclause 18.1.5.3 of ETS 300 347-1 [2]).

The TPs use the generic term "prot\_switch\_over trigger event" to indicate any output of the monitor functions. Each TP using that term is valid for any trigger event.

### 5.1.4 Requirements not covered by test purposes

The contents of this subclause are identical to subclause 5.1.4 of ETS 300 324-3 [1] with the following additional items:

- it is not possible to verify the state of the ISDN-PRA port FSM, Link control protocol, the BCC protocol and the Protection protocol;
- the user failure/network failure indication procedure of the ISDN-PRA port FSM is not tested because there is no testable reaction on the V5-interface specified;
- it is not physically verified that bearer channels are connected correctly to the UP.

### 5.1.5 Initial states

The initial states of the various V5.2 protocols are defined as follows:

<b>CTRL_COM_INIT</b>	Refer to subclause 5.1.5 of ETS 300 324-3 [1].
<b>CTRL_PORT_INIT</b>	This state is identical to the state in subclause 5.1.5 of ETS 300 324-3 [1] with addition of ISDN-PRA.
<b>PSTN_INIT</b>	Refer to subclause 5.1.5 of ETS 300 324-3 [1].
<b>LINK_INIT</b>	Initial state to start preambing the LINK test purposes
AN1	(In Service State), Link control protocol
AN2.0	(Link Operational State), Link Control FSM
<b>BCC_INIT</b>	Initial state to start preambing the BCC test purposes
ANBcc0	(Null State), BCC Protocol

**PROTECT\_INIT** Initial state to start preambuling the Protection test purposes.  
Active and stand-by C-channels are allocated according to subclause 5.1.6.  
**SOANO** (Null State), Protection protocol

### 5.1.6 Test and data configuration requirements

The contents of this subclause are identical to subclause 5.1.6 of ETS 300 324-3 [1] with the following additions.

Each V5.2-link shall be provisioned in a way, that the IUT tries to enter the "link operational" state after system start-up.

If PICS item N9 (see ETS 300 347-2 [3]) is set to yes, only the primary and secondary link shall be provisioned. Protection group 1 (logical C-channel 1) shall contain the control, link control, BCC and protection C-paths.

Protection group 2 shall consist of the following constituents:

- a) if only one of the PICS items N11, N12 or M2 is set to yes (see ETS 300 347-2 [3]), the logical C-channel 2 shall contain the related C-path signalling;
- b) if at least two of the PICS items N11, N12 or M2 are set to yes (see ETS 300 347-2 [3]), the related C-paths shall be mapped to two logical C-channels (2 and 3).

The logical C-channel 2 shall be located on TS 15 of the primary link. The logical C-channel 3 (if present) shall be located on TS 31 of the primary link. TS 15 of the secondary link shall be provisioned as standby channel for protection group 2.

The secondary link will be used for testing the link control procedures without provoking protection switching.

If PICS item N12 (see ETS 300 347-2 [3]) is set to yes only one ISDN-PRA port shall be provisioned.

On receipt of a MDU-LAI the IUT system management shall apply the link identification procedure.

If PICS item R5.4 (see ETS 300 347-2 [3]) is set to yes, the Accelerated port state alignment is implemented and the IUT have the possibility to send the primitive MDU-CTRL(UBA-request) to the LT1. In case of user port tests (see subclause 5.2.3.2) the LT1 shall respond with the primitive MDU-CTRL(UBA-rejected).

## 5.2 Control protocol

### 5.2.1 Basic interconnection tests (V5NWKAN/CTRL/IT)

Initial state of the IUT: power on  
Preamble: reset IUT  
Postamble: -

TP11\_\_SM\_01 Run the test step STARTUP\_AN (refer to subclause 4.3.1.1)  
(\*)

### 5.2.2 Capability tests (V5NWKAN/CTRL/CA)

The contents of this subclause are identical to subclause 5.2.2 of ETS 300 324-3 [1].

### 5.2.3 Valid behaviour tests (V5NWKAN/CTRL/BV)

#### 5.2.3.1 V5NWKAN/CTRL/BV/COM

The contents of this subclause are identical to subclause 5.2.3.1 of ETS 300 324-3 [1].

**5.2.3.2 V5NWKAN/CTRL/BV/PORT**

**5.2.3.2.1 V5NWKAN/CTRL/BV/PORT/TRANS**

The contents of this subclause are identical to subclause 5.2.3.2.1 of ETS 300 324-3 [1].

**5.2.3.2.2 V5NWKAN/CTRL/BV/PORT/PSTN**

The contents of this subclause are identical to subclause 5.2.3.2.2 of ETS 300 324-3 [1].

**5.2.3.2.3 V5NWKAN/CTRL/BV/PORT/ISDNBA**

The contents of this subclause are identical to subclause 5.2.3.2.3 of ETS 300 324-3 [1].

**5.2.3.2.4 V5NWKAN/CTRL/BV/PORT/ISDNPRA**

Refer to ETS 300 347-1 [2], table 7 and figures L9.1 to L.9.11.

This test group is only valid if PICS item N12 (see ETS 300 347-2 [3]) is set to yes.

As the Port control protocol transport is tested separately (see subclause 5.2.3.2.1), the TRANSPORT protocol is not any more mentioned in the PORT CONTROL test purposes.

Initial state of the IUT: CTRL\_COM\_INIT, CTRL\_PORT\_INIT

Preamble: CTRL\_ISDNPRA\_AN20\_10

Postamble: CTRL\_ISDNPRA\_AN20\_10

TP1326SM\_01 (\*) On receipt of a local unblock\_req (MPH-UBR) the IUT shall send a message containing the control\_function\_element IE FE202 (unblock\_req).

On receipt of a message containing the control\_function\_element IE FE201 (unblock\_ack) the IUT ISDN-PRA user port FSM will enter state "Access operational", AN2.0.

TP1326S1002 (\*) On receipt of a local block\_cmd (MPH-BI) the IUT shall send a message containing the control\_function\_element IE FE204 (block\_cmd) and the IUT ISDN-PRA user port FSM will re-enter the state "Blocked", AN1.0.

TP1326SM\_03 On receipt of a message containing the control\_function\_element IE FE201 (unblock\_req) the IUT shall send a message containing the control\_function\_element IE FE202 (unblock\_ack) and the IUT ISDN-PRA user port FSM will enter state "Access operational", AN2.0.

TP1326S1004 On receipt of a message containing the control\_function\_element IE FE203 (block\_cmd) the IUT ISDN-PRA user port FSM will re-enter the state "Blocked", AN1.0.

TP1326SM\_05 (\*) Verify the AN "Local blocking/unblocking".

Preamble the TP with the TP1326SM\_03 (subclause 5.2.3.2.4) to reach the "Access operational" state.

On receipt of a message containing the control\_function\_element IE FE201 (unblock\_req) the IUT shall send a message containing the control\_function\_element IE FE202 (unblock\_ack).

On receipt of a local block\_req (MPH-BR) the IUT shall send a message containing the control\_function\_element IE FE205 (block\_req).

On receipt of a message containing the control\_function\_element IE FE203 (block\_cmd) and the IUT ISDN-PRA user port FSM shall return back to the state "Blocked", AN1.0.

- TP1326SM\_06 (\*) Verify the AN "Local blocking/unblocking".
- Preamble the TP with the TP1326SM\_03 to reach the "Access operational" state.
- On receipt of a local unblock\_req (MPH-UBR) the IUT shall send a message containing the control\_function\_element IE FE202 (unblock\_req).
- On receipt of a local block\_req (MPH-BR) the IUT shall send a message containing the control\_function\_element IE FE205 (block\_req).
- On receipt of a local block\_cmd (MPH-BI) the IUT shall send a message containing the control\_function\_element IE FE204 (block\_cmd) and the IUT ISDN-PRA user port FSM shall return to the state "Blocked", AN1.0.
- TP1326SM\_07 (\*) Verification of events in state AN1.0, "Local unblock".
- On receipt of a local unblock\_req (MPH-UBR) the IUT shall send a message containing the control\_function\_element IE FE202 (unblock\_req).
- On receipt of a local unblock\_req (MPH-UBR) the second time, the IUT shall send a message containing the control\_function\_element IE FE202 (unblock\_req) once more.
- On receipt of a local block\_cmd (MPH-BI) the IUT shall send a message containing the control\_function\_element IE FE204 (block\_cmd) and the IUT ISDN-PRA user port FSM shall re-enter the state port state AN1.0 (Blocked).
- TP1326S2008 (\*) On receipt of grading in the AN\_ISDNPRA\_user\_port the IUT shall send a FE206\_grading. The IUT shall re-enter the port state AN 2.0 (Access operational).
- TP1326S2009 (\*) On receipt of a FE207\_D-channel\_block, the IUT shall re-enter the port state AN 2.0 (Access operational).
- TP1326S2010 (\*) On receipt of a FE208\_D-channel\_unblock the IUT shall re-enter the port state AN 2.0 (Access operational).
- TP1326S2011 (\*) Verification of "User failure indication".
- On receipt of a user failure (MPH-UF) the IUT shall send a FE209 (TE\_out\_of\_service). The IUT re-enter the port state AN1.0 (Blocked).
- TP1326S2012 (\*) Verification of "Network failure indication".
- On receipt of a network failure (MPH-NF) the IUT shall send a FE210 (Failure\_inside\_network). The IUT re-enters the port state AN1.0 (Blocked).

#### 5.2.4 Inopportune behaviour tests (V5NWKAN/CTRL/BO)

The contents of this subclause are identical to subclause 5.2.4 of ETS 300 324-3 [1].

##### 5.2.4.1 V5NWKAN/CTRL/BO/COM

The contents of this subclause are identical to subclause 5.2.4.1 of ETS 300 324-3 [1].

##### 5.2.4.2 V5NWKAN/CTRL/BO/PORT

###### 5.2.4.2.1 V5NWKAN/CTRL/BO/PORT/TRANS

The contents of this subclause are identical to subclause 5.2.4.2.1 of ETS 300 324-3 [1].

###### 5.2.4.2.2 V5NWKAN/CTRL/BO/PORT/PSTN

The contents of this subclause are identical to subclause 5.2.4.2.2 of ETS 300 324-3 [1].

#### 5.2.4.2.3 V5NWKAN/CTRL/BO/PORT/ISDNBA

The contents of this subclause are identical to subclause 5.2.4.2.3 of ETS 300 324-3 [1].

#### 5.2.4.2.4 V5NWKAN/CTRL/BO/PORT/ISDNPRA

Refer to ETS 300 347-1 [2], table 35 and figures L.14.1 to L.14.8.

This test group is only valid if PICS item N12 (see ETS 300 347-2 [3]) is set to yes.

As the Port control protocol is tested separately (see subclause 5.2.3.2.1), the PORT CONTROL ACK messages are not mentioned in the following TPs any more.

Initial state of the IUT: CTRL\_COM\_INIT, CTRL\_PORT\_INIT  
Preamble: CTRL\_ISDNPRA\_AN20\_10  
Postamble: CTRL\_ISDNPRA\_AN20\_10

TP1426SM\_01 (\*) On receipt of service grading (MPH-GI) the IUT shall send no message in the blocked state.

TP1426SM\_02 (\*) On receipt of a FE207 (D-channel\_block), the IUT will remain in the port state AN 1.0 (Blocked).

TP1426SM\_03 (\*) On receipt of a FE208 (D-channel\_unblock), the IUT will remain in the port state AN 1.0 (Blocked).

#### 5.2.5 Invalid behaviour tests (V5NWKAN/CTRL/BI)

The contents of this subclause are identical to subclause 5.2.4 of ETS 300 324-3 [1].

#### 5.2.6 Timer expiry and counter mismatch tests (V5NWKAN/CTRL/TI)

The contents of this subclause are identical to subclause 5.2.5 of ETS 300 324-3 [1].

### 5.3 PSTN protocol

The contents of this subclause are identical to subclause 5.2.5 of ETS 300 324-3 [1].

### 5.4 Link control protocol

#### 5.4.1 Basic interconnection tests (V5NWKAN/LINK/IT)

Initial state of the IUT: LINK\_INIT  
Preamble: -  
Postamble: -

TP31\_\_SM\_01 Refer to TP11\_\_SM\_01 in subclause 5.2.1.

#### 5.4.2 Capability tests (V5NWKAN/LINK/CA)

Refer to ETS 300 347-1 [2], table 24.

Initial state of the IUT: LINK\_INIT  
Preamble: -  
Postamble: -

TP32\_\_SM\_01 On receipt of a LINK CONTROL message containing the link\_control\_function IE FE301 (link\_unblock\_req), the IUT shall send a LINK CONTROL ACK message containing the same link\_control\_function IE.

Refer to ETS 300 347-1 [2], subclause 16.2.4.4, table 16.

### 5.4.3 Valid behaviour tests (V5NWKAN/LINK/BV)

#### 5.4.3.1 V5NWKAN/LINK/BV/TRANS

Refer to ETS 300 347-1 [2], table 24.

Initial state of the IUT: LINK\_INIT  
Preamble: -  
Postamble: -

TP33\_1S1\_01 Refer to TP32\_\_S1\_01 in subclause 5.4.2.

TP33\_1S2\_02 On receipt of a LINK CONTROL ACK containing the link\_control\_function IE FE302 (link\_unblock\_req) after sending a LINK CONTROL message containing the link\_control\_function IE FE302 (link\_unblock\_req), the IUT shall not repeat the original message.

Refer to ETS 300 347-1 [2], subclause 16.2.4.4, table 16.

TP33\_1SM\_03 Check that the IUT is able to control messages in both directions at the same time:  
(\* )

On receipt of a FE302 (link\_unblock\_req) the IUT shall send a LINK CONTROL message containing the link\_control\_function IE FE302 (link\_unblock\_req).

On receipt of a LINK CONTROL message containing the link\_control\_function IE FE301 (link\_unblock\_req), the IUT shall send a LINK CONTROL ACK message containing the same link\_control\_function IE.

On receipt of a LINK CONTROL ACK message containing the link\_control\_function IE FE302 (link\_unblock\_req), the IUT shall not repeat the original message.

Refer to ETS 300 347-1 [2], subclause 16.2.4.4, table 16.

#### 5.4.3.2 V5NWKAN/LINK/BV/LINK

Refer to ETS 300 347-1 [2], table 17.

As the Link control protocol is tested separately (see subclause 5.2.3.2.1), the LINK CONTROL ACK messages are not mentioned in the following TPs any longer.

If PICS item N9 (see ETS 300 347-2 [3]) is set to yes, all LINK CONTROL messages shall contain the Layer 3 address (L3addr) of the secondary link (if not stated otherwise).

Initial state of the IUT: LINK\_INIT  
Preamble: -  
Postamble: LINK\_CHECK\_ID

TP33\_7S2001 Non-persistent V5.2 link failure while link is operational.  
(\* )

On detection of a non-persistent V5.2 link failure condition (Alarm Indication Signal (AIS) or Remote Alarm Indication (RAI) which disappears before expiration of TPERs, IUT Link Control FSM receives MPH\_AI in state AN2.0) no message shall appear on the V5.2 interface.

Refer to ETS 300 347-1 [2], subclause 16.2.4.4, table 16.

TP33\_7S1002 Non-persistent V5.2 link failure while link is blocked.

(\*)

(note 1)

Preamble: LINK\_AN20\_10.

On detection of a non-persistent V5.2 link failure condition (AIS or RAI which disappears before expiration of TPERs, IUT Link Control FSM receives MPH\_AI in state AN1.0) no message shall appear on the V5.2 interface.

After LT1 has unblocked the link (LINK\_AN10\_20) the IUT shall invoke the local link identification procedure.

No postamble needed.

Refer to ETS 300 347-1 [2], subclause 16.2.4.4, table 16.

TP33\_7S1103 Non-persistent V5.2 link failure while link is local unblocked.

(\*)

(note 1)

Preamble: LINK\_AN20\_10.

On receipt of a MDU-LUBR (link\_unblock\_req) the IUT shall send a message containing the link\_control\_function IE FE302 (link\_unblock\_req).

On detection of a non-persistent V5.2 link failure condition (AIS or RAI which disappears before expiration of TPERs, IUT Link Control FSM receives MPH\_AI in state AN1.1) no message shall appear on the V5.2 interface.

Postamble:

LT1 sends a message containing the link\_control\_function IE FE301 (link\_unblock\_ack).

Refer to ETS 300 347-1 [2], subclause 16.2.4.4, table 16.

TP33\_7S2204 Non-persistent V5.2 link failure while local link identification procedure.

(\*)

Preamble:

On receipt of a MDU-IDReq (link\_identification\_req) the IUT shall send a message containing the link\_control\_function IE FE-IDReq (link\_identification\_req).

On detection of a non-persistent V5.2 link failure condition (AIS or RAI which disappears before expiration of TPERs, IUT Link Control FSM receives MPH\_AI in state AN2.2) no message shall appear on the V5.2 interface.

Postamble:

LT1 sends a message containing the link\_control\_function IE FE-IDRej (link\_identification\_rej).

Refer to ETS 300 347-1 [2], subclause 16.2.4.4, table 16.



TP33\_7S2105 Non-persistent V5.2 link failure while remote link identification procedure.  
(\* )

Preamble:

On receipt of a message containing the link\_control\_function IE FE-IDReq (link\_identification\_req) the IUT shall send a message containing the link\_control\_function IE FE-IDAck (link\_identification\_ack) and frames with S<sub>a7</sub> bit set to zero.

On detection of a non-persistent V5.2 link failure condition (AIS or RAI which disappears before expiration of TPERs, IUT Link Control FSM receives MPH\_AI in state AN2.1) no message shall appear on the V5.2 interface.

Postamble:

LT1 sends a message containing the link\_control\_function IE FE-IDRel (link\_identification\_rel).

Refer to ETS 300 347-1 [2], subclause 16.2.4.4, table 16.

TP33\_7SM\_06 Persistent V5.2 link failure while link is operational.  
(\* )  
(note 1)

On detection of a persistent V5.2 link failure condition (AIS or RAI persists until the expiration of TPERs, IUT Link Control FSM receives MPH\_DI and enters state AN0.1) no message shall appear on the V5.2 interface.

After the disappearance of the V5.2 link failure condition (IUT Link Control FSM receives MPH\_AI and enters state AN2.0) the IUT shall invoke the local link identification procedure (see subclause 5.1.6, IUT system management receives MDU\_LAI).

No postamble needed.

Refer to ETS 300 347-1 [2], subclause 16.2.4.4, table 16.

TP33\_7SM\_07 Persistent V5.2 link failure while link is blocked.  
(\* )  
(note 1)

Preamble: LINK\_AN20\_10

On detection of a persistent V5.2 link failure condition (AIS or RAI persists until the expiration of TPERs, IUT Link Control FSM receives MPH\_DI and enters state AN0.2) no message shall appear on the V5.2 interface.

After the disappearance of the V5.2 link failure condition (IUT Link Control FSM receives MPH\_AI and enters state AN1.0) no message shall appear on the V5.2 interface.

After LT1 has unblocked the link (LINK\_AN10\_20) the IUT shall invoke the local link identification procedure.

No postamble needed.

Refer to ETS 300 347-1 [2], subclause 16.2.4.4, table 16.

TP33\_7SM\_08 Persistent V5.2 link failure while link is local unblocked.

(\*)  
(note 1)

Preamble:

LINK\_AN20\_10.

On receipt of a MDU-LUBR (link\_unblock\_req) the IUT shall send a message containing the link\_control\_function IE FE302 (link\_unblock\_req).

On detection of a persistent V5.2 link failure condition (AIS or RAI persists until the expiration of TPERS, IUT Link Control FSM receives MPH\_DI and enters state AN0.2) no message shall appear on the V5.2 interface.

After the disappearance of the V5.2 link failure condition (IUT Link Control FSM receives MPH\_AI and enters state AN1.0) no message shall appear on the V5.2 interface.

After LT1 has unblocked the link (LINK\_AN10\_20) the IUT shall invoke the local link identification procedure.

No postamble needed.

Refer to ETS 300 347-1 [2], subclause 16.2.4.4, table 16.

TP33\_7SM\_09 Persistent V5.2 link failure while local link identification procedure.

(\*)  
(note 1)

Preamble:

On receipt of a MDU-IDReq (link\_identification\_req) the IUT shall send a message containing the link\_control\_function IE FE-IDReq (link\_identification\_req).

On detection of a persistent V5.2 link failure condition (AIS or RAI persists until the expiration of TPERS, IUT Link Control FSM receives MPH\_DI and enters state AN0.1) the IUT shall send a message containing the link\_control\_function IE FE-IDRel (link\_identification\_rel).

After the disappearance of the V5.2 link failure condition (IUT Link Control FSM receives MPH\_AI and enters state AN2.0) the IUT shall invoke the local link identification procedure (see subclause 5.1.6, IUT system management receives MDU\_LAI).

No postamble needed.

Refer to ETS 300 347-1 [2], subclause 16.2.4.4, table 16.

- TP33\_7SM\_10 Persistent V5.2 link failure while remote link identification procedure.  
(\*  
(note 1)
- Preamble:  
On receipt of a message containing the link\_control\_function IE FE-IDReq (link\_identification\_req) the IUT shall send a message containing the link\_control\_function IE FE-IDAck (link\_identification\_ack) and frames with S<sub>a7</sub> bit set to zero.
- On detection of a persistent V5.2 link failure condition (AIS or RAI persists until the expiration of TPERs, IUT Link Control FSM receives MPH\_DI and enters state AN0.1) the IUT no message shall appear on the V5.2 interface.
- LT1 sends a message containing the link\_control\_function IE FE-IDRel (link\_identification\_rel)
- After the disappearance of the V5.2 link failure condition (IUT Link Control FSM receives MPH\_AI and enters state AN2.0) the IUT shall invoke the local link identification procedure (see subclause 5.1.6, IUT system management receives MDU\_LAI).
- No postamble needed.
- Refer to ETS 300 347-1 [2], subclause 16.2.4.4, table 16.
- TP33\_7SM\_11 Verify "Local Link Blocking/Unblocking" procedure while link is operational.  
(\*  
(note 1)
- On receipt of a MDU-LBI (link\_block\_cmd) the IUT shall send a message containing the link\_control\_function IE FE304 (link\_block\_cmd).
- On receipt of a MDU-LUBR (link\_unblock\_req) the IUT shall send a message containing the link\_control\_function IE FE302 (link\_unblock\_req).
- LT1 sends a message containing the link\_control\_function IE FE301 (link\_unblock\_ack) (IUT Link Control FSM enters state AN2.0).
- Refer to ETS 300 347-1 [2], subclause 16.2.4.4, table 16.
- TP33\_7S1112 Verify "Repeated Local Link Unblocking" procedure.  
(\*  
(note 1)
- Preamble: LINK\_AN20\_10  
On receipt of a MDU-LUBR (link\_unblock\_req) the IUT shall send a message containing the link\_control\_function IE FE302 (link\_unblock\_req).
- On receipt of a second MDU-LUBR (link\_unblock\_req) the IUT shall repeat the message containing the link\_control\_function IE FE302 (link\_unblock\_req).
- Additional postamble:  
LT1 sends a message containing the link\_control\_function IE FE301 (link\_unblock\_ack) (IUT Link Control FSM enters state AN2.0).
- Refer to ETS 300 347-1 [2], subclause 16.2.4.4, table 16.

- TP33\_7S1113 (\*)  
(note 1) Verify "Cancelled Link Unblocking" procedure.
- Preamble: LINK\_AN20\_10  
On receipt of a MDU-LUBR (link\_unblock\_req) the IUT shall send a message containing the link\_control\_function IE FE302 (link\_unblock\_req).
- On receipt of a MDU-LBI (link\_block\_cmd) the IUT shall send a message containing the link\_control\_function IE FE304 (link\_block\_cmd).
- Additional postamble: LINK\_AN10\_20.
- Refer to ETS 300 347-1 [2], subclause 16.2.4.4, table 16.
- TP33\_7S1114 (\*)  
(note 1) Verify "Rejected Link Unblocking" (FE303) procedure.
- Preamble: LINK\_AN20\_10  
On receipt of a MDU-LUBR (link\_unblock\_req) the IUT shall send a message containing the link\_control\_function IE FE302 (link\_unblock\_req).
- On receipt of a message containing the link\_control\_function IE FE303 (link\_block\_cmd) (IUT Link control protocol enters state AN1.0) the IUT shall send a LINK CONTROL ACK message but no further event shall appear on the V5.2 interface.
- Additional postamble: LINK\_AN10\_20.
- Refer to ETS 300 347-1 [2], subclause 16.2.4.4, table 16.
- TP33\_7SM\_15 (note 1) Verify "Remote Link Blocking/Unblocking" procedure while link is operational.
- On receipt of a sequence of messages containing the link\_control\_function IEs FE303 (link\_block\_cmd), again FE303 (link\_block\_cmd) and FE301 (link\_unblock\_req) the IUT shall send a message containing the link\_control\_function IE FE302 (link\_unblock\_ack).
- Refer to ETS 300 347-1 [2], subclause 16.2.4.4, table 16.
- TP33\_7SM\_16
- TP33\_7SM\_17
- TP33\_7SM\_18 (\*)  
(note 1) Verify "Deferred Link Blocking Request/Unblocking" procedure while link is operational.
- On receipt of a MDU-LBR (deferred\_blocking\_req), the IUT shall send a message containing the link\_control\_function IE FE305 (deferred\_link\_block\_req).
- LT1 sends a message containing the link\_control\_function IE FE303 (link\_block\_cmd).
- On receipt of a MDU-LUBR (link\_unblock\_req), the IUT shall send a message containing the link\_control\_function FE302 (link\_unblock\_req).
- LT1 sends a message containing the link\_control\_function IE FE301 (link\_unblock\_ack).
- Refer to ETS 300 347-1 [2], subclause 16.2.4.4, table 16.

- TP33\_7SM\_19 (\*) (note 1) Verify "Non-Deferred Link Blocking Request/Unblocking" procedure while link is operational.
- On receipt of a MDU-LBRN (non-deferred\_blocking\_req), the IUT shall send a message containing the link\_control\_function IE FE306 (non-deferred\_link\_block\_req).
- LT1 sends a message containing the link\_control\_function IE FE303 (link\_block\_cmd).
- On receipt of a MDU-LUBR (link\_unblock\_req), the IUT shall send a message containing the link\_control\_function FE302 (link\_unblock\_req).
- LT1 sends a message containing the link\_control\_function IE FE301 (link\_unblock\_ack).
- Refer to ETS 300 347-1 [2], subclause 16.2.4.4, table 16.
- TP33\_7SM\_20 (\*) (note 1) Verify "Local Blocking" procedure while persistent V5.2 link failure.
- Preamble:  
Detection of a persistent V5.2 link failure condition (AIS or RAI persists until the expiration of TPERs, IUT Link Control FSM receives MPH\_DI and enters state AN0.1).
- On receipt of a MDU-LBI (link\_block\_cmd) the IUT shall send a message containing the link\_control\_function IE FE304 (link\_block\_cmd).
- After LT1 has unblocked the link (LINK\_AN10\_20) and the disappearance of the V5.2 link failure condition the IUT shall invoke the local link identification procedure.
- No postamble needed.
- Refer to ETS 300 347-1 [2], subclause 16.2.4.4, table 16.
- TP33\_7SM\_21 (\*) (note 1) Verify "Remote Blocking" procedure while persistent V5.2 link failure.
- Preamble:  
Detection of a persistent V5.2 link failure condition (AIS or RAI persists until the expiration of TPERs, IUT Link Control FSM receives MPH\_DI and enters state AN0.1).
- On receipt of a message containing the link\_control\_function IE FE303 (link\_block\_cmd) the IUT shall send a LINK CONTROL ACK message but no further event shall appear on the V5.2 interface.
- On receipt of a second message containing the link\_control\_function IE FE303 (link\_block\_cmd) the IUT shall send a LINK CONTROL ACK message but no further event shall appear on the V5.2 interface.
- On receipt of a message containing the link\_control\_function IE FE301 (link\_unblock\_req) the IUT shall send a message containing the link\_control\_function IE FE303 (link\_block\_cmd)
- After LT1 has unblocked the link (LINK\_AN10\_20) and the disappearance of the V5.2 link failure condition the IUT shall invoke the local link identification procedure.
- No postamble needed.
- Refer to ETS 300 347-1 [2], subclause 16.2.4.4, table 16.

- TP33\_7S2222 (\*)  
(note 1) Verify "Local Blocking procedure" procedure while local link identification.
- Preamble:  
On receipt of a MDU-IDReq (link\_identification\_req) the IUT shall send a message containing the link\_control\_function IE FE-IDReq (link\_identification\_req).
- On receipt of a MDU-LBI (link\_block\_cmd) the IUT shall send a message containing the link\_control\_function IE FE304 (link\_block\_cmd).
- Postamble: LINK\_AN10\_20.
- Refer to ETS 300 347-1 [2], subclause 16.2.4.4, table 16.
- TP33\_7S2223 (\*) Verify "Remote Unblocking" procedure while local link identification.
- Preamble:  
On receipt of a MDU-IDReq (link\_identification\_req) the IUT shall send a message containing the link\_control\_function IE FE-IDReq (link\_identification\_req).
- On receipt of a message containing the link\_control\_function IE FE301 (link\_unblock\_req) and a subsequent MDU-IDReq (link\_identification\_req) the IUT shall send a message containing the link\_control\_function IE FE-IDReq (link\_identification\_req).
- Postamble:  
LT1 sends a message containing the link\_control\_function IE FE-IDRej (link\_identification\_rej).
- Refer to ETS 300 347-1 [2], subclause 16.2.4.4, table 16.
- TP33\_7S2224 (\*)  
(note 1) Verify "Remote Blocking" procedure while local link identification.
- Preamble:  
On receipt of a MDU-IDReq (link\_identification\_req) the IUT shall send a message containing the link\_control\_function IE FE-IDReq (link\_identification\_req).
- On receipt of a message containing the link\_control\_function IE FE303 (link\_block\_cmd) the IUT shall send a LINK CONTROL ACK message but no further event shall appear on the V5.2 interface.
- Postamble: LINK\_AN10\_20.
- Refer to ETS 300 347-1 [2], subclause 16.2.4.4, table 16.
- TP33\_7S2125 Verify "Remote Unblocking" procedure while remote link identification.
- Preamble:  
On receipt of a message containing the link\_control\_function IE FE-IDReq (link\_identification\_req) the IUT shall send a message containing the link\_control\_function IE FE-IDAck (link\_identification\_ack) and frames with S<sub>a7</sub> bit set to zero.
- On receipt of a message containing the link\_control\_function IE FE301 (link\_unblock\_req) the IUT shall send frames with S<sub>a7</sub> bit set to one.

- TP33\_7S2126 (note 1) Verify "Remote Blocking" procedure while remote link identification.
- Preamble:  
On receipt of a message containing the link\_control\_function IE FE-IDReq (link\_identification\_req) the IUT shall send a message containing the link\_control\_function IE FE-IDAck (link\_identification\_ack) and frames with S<sub>a7</sub> bit set to zero.
- On receipt of a message containing the link\_control\_function IE FE303 (link\_block\_cmd) the IUT shall send frames with S<sub>a7</sub> bit set to one.
- Postamble: LINK\_AN10\_20.
- Refer to ETS 300 347-1 [2], subclause 16.2.4.4, table 16.
- TP33\_7S0127 (\*) (note 1) Preamble:  
Detection of a persistent V5.2 link failure condition (AIS or RAI persists until the expiration of TPERs, IUT Link Control FSM receives MPH\_DI and enters state AN0.1).
- On receipt of a message containing the link\_control\_function IE FE301 (link\_unblock\_req) the IUT shall send a message containing the link\_control\_function IE FE304 (link\_block\_cmd)
- After LT1 has unblocked the link (LINK\_AN10\_20) and the disappearance of the V5.2 link failure condition the IUT shall invoke the local link identification procedure.
- No postamble needed.
- TP33\_7SM\_28 (\*) Verify "Successful Local Link Identification" procedure while link is operational.
- On receipt of a MDU-IDReq (link\_identification\_req) the IUT shall send a message containing the link\_control\_function IE FE-IDReq (link\_identification\_req).
- LT1 sends frames with S<sub>a7</sub> bit set to zero.
- On receipt of a message containing the link\_control\_function IE FE-IDAck (link\_identification\_ack) the IUT shall send a message containing the link\_control\_function IE FE-IDRel (link\_identification\_rel).
- Postamble:  
LT1 sends frames with S<sub>a7</sub> bit set to one.
- Refer to ETS 300 347-1 [2], subclause 16.2.4.4, table 16.
- TP33\_7SM\_29 (\*) Verify "Unsuccessful Local Link Identification" procedure while link is operational.
- On receipt of a MDU-IDReq (link\_identification\_req) the IUT shall send a message containing the link\_control\_function IE FE-IDReq (link\_identification\_req).
- On receipt of a message containing the link\_control\_function IE FE-IDAck (link\_identification\_ack) the IUT shall send a message containing the link\_control\_function IE FE-IDRel (link\_identification\_rel).
- Refer to ETS 300 347-1 [2], subclause 16.2.4.4, table 16.

TP33\_7SM\_30 Verify "Rejected Local Link Identification" procedure while link is operational.

(\*)

On receipt of a MDU-IDReq (link\_identification\_req) the IUT shall send a message containing the link\_control\_function IE FE-IDReq (link\_identification\_req).

On receipt of a message containing the link\_control\_function IE FE-IDRej (link\_identification\_rej) the IUT shall send a LINK CONTROL ACK message but no further message shall appear on the V5.2 interface.

Refer to ETS 300 347-1 [2], subclause 16.2.4.4, table 16.

TP33\_7SM\_31 Verify "Successful Remote Link Identification" procedure while link is operational.

On receipt of a message containing the link\_control\_function IE FE-IDReq (link\_identification\_req) the IUT shall send a message containing the link\_control\_function IE FE-IDAck (link\_identification\_ack) and frames with S<sub>a7</sub> bit set to zero.

On receipt of a second message containing the link\_control\_function IE FE-IDReq (link\_identification\_req) the IUT shall send a LINK CONTROL ACK message but no further message shall appear on the V5.2 interface.

On receipt of a message containing the link\_control\_function IE FE-IDRel (link\_identification\_rel) the IUT shall send frames with S<sub>a7</sub> bit set to one.

No postamble needed.

Refer to ETS 300 347-1 [2], subclause 16.2.4.4, table 16.

TP33\_7S2232 Verify "Link Identification Collision" procedure on one link.

(\*)

Preamble:

On receipt of a MDU-IDReq (link\_identification\_req) the IUT shall send a message containing the link\_control\_function IE FE-IDReq (link\_identification\_req).

On receipt of a message containing the link\_control\_function IE FE-IDReq (link\_identification\_req) for the same link the IUT shall send a message containing the link\_control\_function IE FE-IDAck (link\_identification\_ack) and frames with S<sub>a7</sub> bit set to zero.

Postamble:

LT1 sends a message containing the link\_control\_function IE FE-IDRel (link\_identification\_rel).

Refer to ETS 300 347-1 [2], subclause 16.2.4.4, table 16.



- TP33\_7S2233 (\*)  
(note 1) Verify "Link Identification Collision" procedure on different links.
- Preamble:  
On receipt of a MDU-IDReq (link\_identification\_req) the IUT shall send a message containing the link\_control\_function IE FE-IDReq (link\_identification\_req).
- On receipt of a message containing the link\_control\_function IE FE-IDReq (link\_identification\_req) and L3addr of the primary link, the IUT shall send a message containing the link\_control\_function IE FE-IDAck (link\_identification\_ack) and L3addr of the primary link and frames with S<sub>a7</sub> bit set to zero. .
- Postamble:  
LT1 sends a message containing the link\_control\_function IE FE-IDRel (link\_identification\_rel).
- Refer to ETS 300 347-1 [2], subclause 16.2.4.4, table 16.
- TP33\_7S1034 (note 1) Verify "Remote Link Identification" procedure while link is blocked.
- Preamble: LINK\_AN20\_10
- On receipt of a message containing the link\_control\_function IE FE-IDReq (link\_identification\_req) the IUT shall send a message containing the link\_control\_function IE FE304 (link\_block\_cmd).
- Additional postamble: LINK\_AN10\_20.
- Refer to ETS 300 347-1 [2], subclause 16.2.4.4, table 16.
- TP33\_7S1035 (note 1) Preamble: LINK\_AN20\_10
- On receipt of a message containing the link\_control\_function IE FE-IDRel (link\_identification\_rel) the IUT shall send a LINK CONTROL ACK message but no further event shall appear on the V5.2 interface.
- Additional postamble: LINK\_AN10\_20.
- Refer to ETS 300 347-1 [2], subclause 16.2.4.4, table 16.
- TP33\_7S1036 (note 1) Preamble: LINK\_AN20\_10
- On receipt of a message containing the link\_control\_function IE FE-IDRej (link\_identification\_rej) the IUT shall send a LINK CONTROL ACK message but no further event shall appear on the V5.2 interface.
- Additional postamble: LINK\_AN10\_20.
- Refer to ETS 300 347-1 [2], subclause 16.2.4.4, table 16.
- TP33\_7S1137 (\*)  
(note 1) Preamble: LINK\_AN20\_10
- On receipt of a MDU-LUBR (link\_unblock\_req) the IUT shall send a message containing the link\_control\_function IE FE302 (link\_unblock\_req).
- On receipt of a message containing the link\_control\_function IE FE-IDReq (link\_identification\_req) the IUT shall send a message containing the link\_control\_function IE FE-IDRej (link\_identification\_rej).
- Additional postamble: LINK\_AN11\_20.
- Refer to ETS 300 347-1 [2], subclause 16.2.4.4, table 16.

TP33\_7S1138 Preamble: LINK\_AN20\_10

(\*)

(note 1)

On receipt of a MDU-LUBR (link\_unblock\_req) the IUT shall send a message containing the link\_control\_function IE FE302 (link\_unblock\_req).

On receipt of a message containing the link\_control\_function IE FE-IDRel (link\_identification\_rel) the IUT shall send a LINK CONTROL ACK message but no further event shall appear on the V5.2 interface.

Additional postamble: LINK\_AN11\_20.

Refer to ETS 300 347-1 [2], subclause 16.2.4.4, table 16.

TP33\_7S1139 Preamble: LINK\_AN20\_10

(\*)

(note 1)

On receipt of a MDU-LUBR (link\_unblock\_req) the IUT shall send a message containing the link\_control\_function IE FE302 (link\_unblock\_req).

On receipt of a message containing the link\_control\_function IE FE-IDRej (link\_identification\_rej) the IUT shall send a LINK CONTROL ACK message but no further event shall appear on the V5.2 interface.

Additional postamble: LINK\_AN11\_20.

Refer to ETS 300 347-1 [2], subclause 16.2.4.4, table 16.

TP33\_7SM\_40 Remote link identification while persistent V5.2 link failure.

(\*)

(note 1)

Preamble:

Detection of a persistent V5.2 link failure condition (AIS or RAI persists until the expiration of TPERs, IUT Link Control FSM receives MPH\_DI and enters state AN0.1).

On receipt of a message containing the link\_control\_function IE FE-IDReq (link\_identification\_req) the IUT shall send a message containing the link\_control\_function IE FE304 (link\_block\_cmd).

On receipt of a second message containing the link\_control\_function IE FE-IDReq (link\_identification\_req) the IUT shall repeat the message containing the link\_control\_function IE FE304 (link\_block\_cmd).

After LT1 has unblocked the link (LINK\_AN10\_20) and the disappearance of the V5.2 link failure condition the IUT shall invoke the local link identification procedure.

No postamble needed.

Refer to ETS 300 347-1 [2], subclause 16.2.4.4, table 16.

TP33\_7S0141 Preamble:

(\*)

(note 1)

Detection of a persistent V5.2 link failure condition (AIS or RAI persists until the expiration of TPERs, IUT Link Control FSM receives MPH\_DI and enters state AN0.1).

On receipt of a message containing the link\_control\_function IE FE-IDRej (link\_identification\_rej) the IUT shall send a LINK CONTROL ACK message but no further event shall appear on the V5.2 interface.

After the disappearance of the V5.2 link failure condition and the unblocking of the link, the IUT shall invoke the local link identification procedure.

No postamble needed.

Refer to ETS 300 347-1 [2], subclause 16.2.4.4, table 16.

NOTE 1: These TPs are only applicable if PICS item N9 (see ETS 300 347-2 [3]) is set to yes.

NOTE 2: These TPs are only applicable if PICS item N9 (see ETS 300 347-2 [3]) is set to no.

#### 5.4.4 Inopportune behaviour tests (V5NWKAN/LINK/BO)

##### 5.4.4.1 V5NWKAN/LINK/BO/TRANS

Refer to ETS 300 347-1 [2], table 24.

Initial state of the IUT: LINK\_INIT

Preamble: -

Postamble: -

TP34\_1S1\_01 On receipt of a LINK CONTROL ACK message the IUT shall ignore the message.

##### 5.4.4.2 V5NWKAN/LINK/BO/LINK

Refer to ETS 300 347-1 [2], table 16.

Initial state of the IUT: LINK\_INIT

Preamble: -

Postamble: LINK\_CHECK\_ID

TP34\_7S0101 Preamble:  
(\* Detection of a persistent V5.2 link failure condition (AIS or RAI persists until the  
(note) expiration of TPERs, IUT Link Control FSM receives MPH\_DI and enters state AN0.1).

On receipt of a message containing the link\_control\_function IE FE-IDAck (link\_identification\_ack) the IUT shall send a LINK CONTROL ACK message but no further event shall appear on the V5.2 interface.

On the disappearance of the V5.2 link failure condition the IUT shall invoke the local link identification procedure.

No postamble needed.

Refer to ETS 300 347-1 [2], subclause 16.2.4.4, table 16.

TP34\_7S0202 Preamble:  
(\* LINK\_AN20\_10 and detection of a persistent V5.2 link failure condition (AIS or RAI  
(note) persists until the expiration of TPERs, IUT Link Control FSM receives MPH\_DI and enters state AN0.2).

On receipt of a message containing the link\_control\_function IE FE-IDAck (link\_identification\_ack) the IUT shall send a LINK CONTROL ACK message but no further event shall appear on the V5.2 interface.

After LT1 has unblocked the link (LINK\_AN10\_20) and the disappearance of the V5.2 link failure condition the IUT shall invoke the local link identification procedure.

No postamble needed.

Refer to ETS 300 347-1 [2], subclause 16.2.4.4, table 16.

TP34\_7S0203 Preamble:  
(\* LINK\_AN20\_10 and detection of a persistent V5.2 link failure condition (AIS or RAI  
(note) persists until the expiration of TPERS, IUT Link Control FSM receives MPH\_DI and enters state AN0.2).

On receipt of a message containing the link\_control\_function IE FE-IDRel (link\_identification\_rel) the IUT shall send a LINK CONTROL ACK message but no further event shall appear on the V5.2 interface.

After LT1 has unblocked the link (LINK\_AN10\_20) and the disappearance of the V5.2 link failure condition the IUT shall invoke the local link identification procedure.

No postamble needed.

Refer to ETS 300 347-1 [2], subclause 16.2.4.4, table 16.

TP34\_7S0204 Preamble:  
(\* LINK\_AN20\_10 and detection of a persistent V5.2 link failure condition (AIS or RAI  
(note) persists until the expiration of TPERS, IUT Link Control FSM receives MPH\_DI and enters state AN0.2).

On receipt of a message containing the link\_control\_function IE FE-IDRej (link\_identification\_rej) the IUT shall send a LINK CONTROL ACK message but no further event shall appear on the V5.2 interface.

After LT1 has unblocked the link (LINK\_AN10\_20) and the disappearance of the V5.2 link failure condition the IUT shall invoke the local link identification procedure.

No postamble needed.

Refer to ETS 300 347-1 [2], subclause 16.2.4.4, table 16.

TP34\_7S1005 Preamble: LINK\_AN20\_10 .  
(note) On receipt of a message containing the link\_control\_function IE FE-IDAck (link\_identification\_ack) the IUT shall send a LINK CONTROL ACK message but no further event shall appear on the V5.2 interface.

Additional postamble: LINK\_AN10\_20.

Refer to ETS 300 347-1 [2], subclause 16.2.4.4, table 16.

TP34\_7S1106 Preamble: LINK\_AN20\_10.  
(\* On receipt of a MDU-LUBR (link\_unblock\_req) the IUT shall send a message  
(note) containing the link\_control\_function IE FE302 (link\_unblock\_req).

On receipt of a message containing the link\_control\_function IE FE-IDAck (link\_identification\_ack) the IUT shall send a LINK CONTROL ACK message but no further event shall appear on the V5.2 interface.

Additional postamble: LINK\_AN11\_20.

Refer to ETS 300 347-1 [2], subclause 16.2.4.4, table 16.

TP34\_7S2007 On receipt of a message containing the link\_control\_function IE FE-IDAck (link\_identification\_ack) the IUT shall send a LINK CONTROL ACK message but no further event shall appear on the V5.2 interface.

Refer to ETS 300 347-1 [2], subclause 16.2.4.4, table 16.

TP34\_7S2008 On receipt of a message containing the link\_control\_function IE FE-IDRel (link\_identification\_rel) the IUT shall send a LINK CONTROL ACK message but no further event shall appear on the V5.2 interface.

Refer to ETS 300 347-1 [2], subclause 16.2.4.4, table 16.

TP34\_7S2009 On receipt of a message containing the link\_control\_function IE FE-IDRej (link\_identification\_rej) the IUT shall send a LINK CONTROL ACK message but no further event shall appear on the V5.2 interface.

Refer to ETS 300 347-1 [2], subclause 16.2.4.4, table 16.

TP34\_7S2110 Preamble:  
On receipt of a message containing the link\_control\_function IE FE-IDReq (link\_identification\_req) the IUT shall send a message containing the link\_control\_function IE FE-IDAck (link\_identification\_ack) and frames with S<sub>a7</sub> bit set to zero.

On receipt of a message containing the link\_control\_function IE FE-IDRej (link\_identification\_rej) the IUT shall send a LINK CONTROL ACK message but no further event shall appear on the V5.2 interface.

Postamble:

On receipt of a message containing the link\_control\_function IE FE-IDRel (link\_identification\_rel) the IUT shall send frames with S<sub>a7</sub> bit set to one.

Refer to ETS 300 347-1 [2], subclause 16.2.4.4, table 16.

TP34\_7S2111 Preamble:  
On receipt of a message containing the link\_control\_function IE FE-IDReq (link\_identification\_req) the IUT shall send a message containing the link\_control\_function IE FE-IDAck (link\_identification\_ack) and frames with S<sub>a7</sub> bit set to zero.

On receipt of a message containing the link\_control\_function IE FE-IDAck (link\_identification\_ack) the IUT shall send a LINK CONTROL ACK message but no further event shall appear on the V5.2 interface.

Postamble:

On receipt of a message containing the link\_control\_function IE FE-IDRel (link\_identification\_rel) the IUT shall send frames with S<sub>a7</sub> bit set to one.

Refer to ETS 300 347-1 [2], subclause 16.2.4.4, table 16.

TP34\_7S2212 Preamble:  
(\* On receipt of a MDU-IDReq (link\_identification\_req) the IUT shall send a message containing the link\_control\_function IE FE-IDReq (link\_identification\_req).

On receipt of a message containing the link\_control\_function IE FE-IDRel (link\_identification\_rel) the IUT shall send a LINK CONTROL ACK message but no further event shall appear on the V5.2 interface.

Postamble:

LT1 sends a message containing the link\_control\_function IE FE-IDRej (link\_identification\_rej).

Refer to ETS 300 347-1 [2], subclause 16.2.4.4, table 16.

NOTE: These TPs are only applicable if PICS item N9 (see ETS 300 347-2 [3]) is set to yes.

#### 5.4.5 Invalid behaviour tests (V5NWKAN/LINK/BI)

Refer to ETS 300 347-1 [2], subclause 16.3.5.

##### 5.4.5.1 V5NWKAN/LINK/BI/TRANS

Initial state of the IUT: LINK\_INIT

Preamble: -

Postamble: -

TP35\_1S1\_01 Check that the IUT discards messages having less than 4 octets.

TP35\_1S1\_02 (protocol discriminator error)

Check that the IUT discards a message containing an unspecified protocol\_discriminator IE.

TP35\_1S1\_03 (L3 address error)

Check that the IUT discards a message containing an unprovisioned L3addr IE.

TP35\_1S1\_04 (message type error)

Check that the IUT discards a message containing an unspecified message\_type IE.

TP35\_1S1\_05 (repeated IE)

Check that the IUT discards a message containing two repeated link\_control\_function IEs.

TP35\_1S1\_06 (mandatory IE missing)

Check that the IUT discards a message containing no link\_control\_function IE.

TP35\_1S1\_07 (unrecognized IE)

Check that the IUT discards a message containing an unspecified link\_control\_function.

TP35\_1S1\_08 (content error of mandatory IE)

Check that the IUT discards a message containing an incorrect link\_control\_function IE.

#### 5.4.6 Timer expiry and counter mismatch tests (V5NWKAN/LINK/TI)

##### 5.4.6.1 V5NWKAN/LINK/TI/TRANS

Refer to ETS 300 347-1 [2], table 25.

Initial state of the IUT: LINK\_INIT  
Preamble: -  
Postamble: -

TP36\_1S2\_01 Preamble:  
On receipt of a LINK CONTROL message containing the link\_control\_function IE FE301 (link\_unblock\_req) the IUT shall send a LINK CONTROL ACK message containing the same link\_control\_function IE.

On receipt of a FE302 (link\_unblock\_ack) the IUT shall send a LINK CONTROL message containing the link\_control\_function IE FE302 (link\_unblock\_ack).

On receipt of a LINK CONTROL ACK messages after NLCO1 repetitions of the LINK CONTROL message, the IUT shall stop repeating the original message.

TP36\_1S2\_02 Preamble:  
On receipt of a LINK CONTROL message containing the link\_control\_function IE FE301 (link\_unblock\_req) the IUT shall send a LINK CONTROL ACK message containing the same link\_control\_function IE.

On receipt of a FE302 (link\_unblock\_ack) the IUT shall send a LINK CONTROL message containing the link\_control\_function IE FE302 (link\_unblock\_ack).

On receipt of a LINK CONTROL ACK message containing not the same link\_control\_function IE, the IUT shall ignore the message.

On receipt of a LINK CONTROL ACK messages after NLCO1 repetitions of the LINK CONTROL message, the IUT shall stop repeating the original message.

#### 5.5 BCC protocol

If not stated otherwise, the BCC messages sent by the IUT or LT1 shall have the following contents:

- a) each ALLOCATION/DE-ALLOCATION message shall contain the V5\_TS\_ID IE for TS 1 on the primary link;
- b) the override bit in the V5\_TS\_ID IE shall be set to zero;
- c) each response of the IUT respectively LT1 on BCC messages shall contain the same reference\_number IE as the original message;
- d) for ISDN port applications, the ISDN\_port\_TS\_ID IE shall contain the ISDN UP TS number 1 (channel B1).

The global pre- and postambles depend on the provisioned data configuration with relation to the PICS items N11, N12 and M2 (see ETS 300 347-2 [3], subclause 6.6.1).

Preambles given in a specific TP have to be applied after performing the global preamble, specific postambles have to be applied before performing the global postamble.

### 5.5.1 Basic interconnection tests (V5NWKAN/BCC/IT)

Initial state of the IUT: BCC\_INIT  
Preamble: -  
Postamble: -

TP41\_\_SM\_01 Refer to TP11\_\_SM\_01 (subclause 5.2.1).

### 5.5.2 Capability tests (V5NWKAN/BCC/CA)

Refer to ETS 300 347-1 [2], table 48.

Initial state of the IUT: BCC\_INIT  
Preamble: CTRL\_PSTN\_AN10\_20, CTRL\_ISDNBA\_AN10\_20,  
CTRL\_ISDNPRA\_AN10\_20  
Postamble: CTRL\_PSTN\_AN20\_10, CTRL\_ISDNBA\_AN20\_10,  
CTRL\_ISDNPRA\_AN20\_10

TP42\_\_S0\_01 "Allocation/De-allocation for PSTN UPs"  
(note 1)

On receipt of an ALLOCATION message containing a PSTN UP\_ID IE, the IUT shall send an ALLOCATION COMPLETE message.

On receipt of a DE-ALLOCATION message, the IUT shall send a DE-ALLOCATION COMPLETE message.

TP42\_\_S0\_02 "Allocation/De-allocation for ISDN BA UPs"  
(note 2)

On receipt of an ALLOCATION message containing an ISDN BA UP\_ID IE, the IUT shall send an ALLOCATION COMPLETE message.

On receipt of a DE-ALLOCATION message, the IUT shall send a DE-ALLOCATION COMPLETE message.

TP42\_\_S0\_03 "Allocation/De-allocation for ISDN PRA UPs"  
(note 3)

On receipt of an ALLOCATION message containing an ISDN PRA UP\_ID IE, the IUT shall send an ALLOCATION COMPLETE message.

On receipt of a DE-ALLOCATION message, the IUT shall send a DE-ALLOCATION COMPLETE message.

TP42\_\_S0\_04 "Allocation/De-allocation of multi slot connections"  
(note 4)

On receipt of an ALLOCATION message containing a multi-slot\_map IE, the IUT shall send an ALLOCATION COMPLETE message.

On receipt of a DE-ALLOCATION message containing a multi-slot\_map IE, the IUT shall send a DE-ALLOCATION COMPLETE message.

NOTE 1: This TP is only applicable if PICS item M2 (see ETS 300 347-2 [3]) is set to yes.

NOTE 2: This TP is only applicable if PICS item N11 (see ETS 300 347-2 [3]) is set to yes.

NOTE 3: This TP is only applicable if PICS item N12 (see ETS 300 347-2 [3]) is set to yes.

NOTE 4: This TP is only applicable if PICS item N8 (see ETS 300 347-2 [3]) is set to yes.



### 5.5.3 Valid behaviour tests (V5NWKAN/BCC/BV)

Refer to ETS 300 347-1 [2], table 48.

Initial state of the IUT: BCC\_INIT  
Preamble: CTRL\_PSTN\_AN10\_20, CTRL\_ISDNBA\_AN10\_20,  
CTRL\_ISDNPRA\_AN10\_20  
Postamble: CTRL\_PSTN\_AN20\_10, CTRL\_ISDNBA\_AN20\_10,  
CTRL\_ISDNPRA\_AN20\_10

TP43\_\_S0\_01 "Repeated Allocation/De-allocation"  
(note 1)

On receipt of an ALLOCATION message the IUT shall send an ALLOCATION COMPLETE message.

On receipt of a second ALLOCATION message containing the same data, the IUT shall send an ALLOCATION COMPLETE message.

On receipt of a DE-ALLOCATION message, the IUT shall send a DE-ALLOCATION COMPLETE message.

On receipt of a second DE-ALLOCATION message containing the same data, the IUT shall send a DE-ALLOCATION COMPLETE message.

TP43\_\_S0\_02 "Override Allocation Request"  
(note 2)

Preamble: BCC\_CONN

On receipt of a second ALLOCATION message containing the same UP\_ID IE, the same V5\_TS\_ID IE, but set override bit and the ISDN\_port\_TS\_ID IE "B2", the IUT shall send an ALLOCATION COMPLETE message.

Postamble: BCC\_REL

TP43\_\_S0\_03 "Unsuccessful Allocation, Connection already present at PSTN UP"  
(note 3)

Preamble: BCC\_CONN

On receipt of a second ALLOCATION message containing the same PSTN UP\_ID IE but a different V5\_TS\_ID IE (TS 2 on the primary link and set override bit), the IUT shall send an ALLOCATION REJECT message containing a reject\_cause IE with cause type "connection already present at the PSTN UP to a different V5 TS" and diagnostic "UP\_ID IE".

Postamble: BCC\_REL

TP43\_\_S0\_04 "Unsuccessful Allocation, Connection already present at V5 TS"  
(note 1)

Preamble: BCC\_CONN

On receipt of a second ALLOCATION message containing a different UP\_ID IE and the same V5\_TS\_ID IE, the IUT shall send an ALLOCATION REJECT message containing a reject\_cause IE with cause type "connection already present at the V5 TS" and diagnostic "V5\_TS\_ID IE".

Postamble: BCC\_REL

TP43\_\_S0\_05 "Unsuccessful Allocation, Connection already present at ISDN UP"  
(note 2)

Preamble: BCC\_CONN

On receipt of a second ALLOCATION message containing the same UP\_ID IE, a different V5\_TS\_ID IE (TS 2 on the primary link) and the ISDN\_port\_TS\_ID IE "B1", the IUT shall send an ALLOCATION REJECT message containing a reject\_cause IE with cause type "connection already present at the ISDN UP TS to a different V5 TS" and diagnostic "V5\_ISDN\_port\_channel\_ID IE".

Postamble: BCC\_REL

TP43\_\_S0\_06 "Unsuccessful Allocation, UP unavailable"  
(note 1)

Preamble not applicable.

On receipt of an ALLOCATION message, the IUT shall send an ALLOCATION REJECT message containing a reject\_cause IE with cause type "UP unavailable" and diagnostic "UP\_ID IE".

TP43\_\_S0\_07 "Unsuccessful Allocation, UP not provisioned"  
(note 1)

On receipt of an ALLOCATION message containing an UP\_ID IE indicating an unprovisioned UP, the IUT shall send an ALLOCATION REJECT message containing a reject\_cause IE with cause type "UP not provisioned" and diagnostic "UP\_ID IE".

TP43\_\_S0\_08 "Unsuccessful Allocation, Invalid V5.2 link ID"  
(note 1)

On receipt of an ALLOCATION message containing a non-present V5.2 link ID (link number 3), the IUT shall send an ALLOCATION REJECT message containing a reject\_cause IE with cause type "invalid V5.2 link ID" and diagnostic "V5\_TS\_ID IE".

TP43\_\_S0\_09 "Unsuccessful allocation, Invalid UP TS ID"  
(note 4)

On receipt of an ALLOCATION message containing an ISDN BA UP\_ID IE and the ISDN\_port\_TS\_ID IE "B3", the IUT shall send an ALLOCATION REJECT message containing a reject\_cause IE with cause type "Invalid UP TS ID" and diagnostic "V5\_ISDN\_port\_channel\_ID IE".

TP43\_\_S0\_10 "Unsuccessful allocation, V5 TS being used as physical C channel"  
(note 1)

On receipt of an ALLOCATION message containing a V5\_TS\_ID IE (TS 16 on the primary link), the IUT shall send an ALLOCATION REJECT message containing a reject\_cause IE with cause type "V5 TS being used as physical C channel" and diagnostic "V5\_TS\_ID IE".

TP43\_\_S0\_11 "Unsuccessful allocation, V5 link unavailable"  
(note 6)

Preamble: LINK\_AN20\_10 for secondary link.

On receipt of an ALLOCATION message containing a V5.2 link ID (secondary link), the IUT shall send an ALLOCATION REJECT message containing a reject\_cause IE with cause type "V5 link unavailable" and diagnostic "V5\_TS\_ID IE".

Postamble: LINK\_AN10\_20 for secondary link.

- TP43\_\_S0\_12 (note 1) "Unsuccessful De-Allocation, Incompatible V5 TS data "  
Preamble: BCC\_CONN  
On receipt of a DE-ALLOCATION message containing a different V5\_TS\_ID IE, the IUT shall send a DE-ALLOCATION REJECT message containing a reject\_cause IE with cause type "De-allocation cannot be completed due to V5 TS incompatibility" and diagnostic "V5\_TS\_ID IE".  
Postamble: BCC\_REL
- TP43\_\_S0\_13 (note 1) "Unsuccessful De-Allocation, Incompatible port data "  
Preamble: BCC\_CONN  
On receipt of a DE-ALLOCATION message containing a different UP\_ID IE, the IUT shall send a DE-ALLOCATION REJECT message containing a reject\_cause IE with cause type "De-allocation cannot be completed due to port data incompatibility" and diagnostic "UP\_ID IE".  
Postamble: BCC\_REL
- TP43\_\_S0\_14 (note 2) "Unsuccessful De-Allocation, Incompatible UP TS data "  
Preamble: BCC\_CONN  
On receipt of a DE-ALLOCATION message containing a different ISDN\_port\_TS\_ID IE "B2", the IUT shall send a DE-ALLOCATION REJECT message containing a reject\_cause IE with cause type "De-allocation cannot be completed due to UP TS data incompatibility" and diagnostic "ISDN\_port\_channel\_ID IE".  
Postamble: BCC\_REL
- TP43\_\_S0\_15 (note 1) "UP ID based Audit"  
Preamble: BCC\_CONN  
On receipt of an AUDIT message containing the same UP\_ID IE, the IUT shall send an AUDIT COMPLETE message containing all relevant data.  
Postamble: BCC\_REL
- TP43\_\_S0\_16 (note 1) "V5 TS ID based Audit"  
Preamble: BCC\_CONN  
On receipt of an AUDIT message containing the same V5\_TS\_ID IE, the IUT shall send an AUDIT COMPLETE message containing all relevant data.  
Postamble: BCC\_REL
- TP43\_\_S0\_17 (note 1) On receipt of an AUDIT message containing an UP\_ID IE, the IUT shall send an AUDIT COMPLETE message containing the connection\_incomplete IE "incomplete normal".
- TP43\_\_S0\_18 (note 1) On receipt of an AUDIT message containing an UP\_ID IE indicating an unprovisioned UP, the IUT shall send an AUDIT COMPLETE message containing the connection\_incomplete IE "UP not provisioned".

TP43\_\_S0\_19 (note 1) On receipt of an AUDIT message containing the V5\_TS\_ID IE (TS 16 on primary link), the IUT shall send an AUDIT COMPLETE message containing the connection\_incomplete IE "TS used as physical C-channel".

TP43\_\_S0\_20 (note 1) On receipt of an AUDIT message containing a non-present V5.2 link ID, the IUT shall send an AUDIT COMPLETE message containing the connection\_incomplete IE "invalid V5.2 link".

TP43\_\_SM\_21 (\*) (note 1) "AN internal failure"  
Preamble BCC\_CONN

On detection of "AN internal failure" of the allocated connection, the IUT shall send an AN FAULT message containing the UP\_ID IE, the ISDN\_port\_channel\_ID (only for ISDN application) and the V5\_TS\_ID IE.

LT1 sends an AN FAULT ACKNOWLEDGE message.

Postamble: BCC\_REL

NOTE 1: It is sufficient to perform these TPs for one the main features N11, N12 or M2 (see ETS 300 347-2 [3]).

NOTE 2: These TPs are only applicable if PICS items N11 or N12 (see ETS 300 347-2 [3]) is set to yes.

NOTE 3: These TPs are only applicable if PICS item M2 (see ETS 300 347-2 [3]) is set to yes.

NOTE 4: These TPs are only applicable if PICS item N11 (see ETS 300 347-2 [3]) is set to yes.

NOTE 5: These TPs are only applicable if PICS item N12 (see ETS 300 347-2 [3]) is set to yes.

NOTE 6: These TPs are only applicable if PICS item N9 (see ETS 300 347-2 [3]) is set to yes

#### 5.5.4 Inopportune behaviour tests (V5NWKAN/BCC/BO)

Refer to ETS 300 347-1 [2], table 48.

It is sufficient to perform these TPs for one the main features N11, N12 or M2 (see ETS 300 347-2 [3]).

Initial state of the IUT: BCC\_INIT  
Preamble: CTRL\_PSTN\_AN10\_20, CTRL\_ISDNBA\_AN10\_20,  
CTRL\_ISDNPRA\_AN10\_20  
Postamble: CTRL\_PSTN\_AN20\_10, CTRL\_ISDNBA\_AN20\_10,  
CTRL\_ISDNPRA\_AN20\_10

TP44\_\_S0\_01 On receipt of an AN FAULT ACKNOWLEDGE message, the IUT shall send a PROTOCOL ERROR message containing the protocol\_error\_cause IE "Message not compatible with BCC protocol state" including corresponding diagnostic.

TP44\_\_S1\_02 (\*) Preamble: BCC\_FAULT  
On receipt of an ALLOCATION message, the IUT shall send a PROTOCOL ERROR message containing the protocol\_error\_cause IE "Message not compatible with BCC protocol state" including corresponding diagnostic.

Postamble:  
LT1 sends an AN FAULT ACKNOWLEDGE message.  
BCC\_REL

- TP44\_\_S1\_03 Preamble: BCC\_FAULT  
(\*)  
On receipt of a DE-ALLOCATION message, the IUT shall send a PROTOCOL ERROR message containing the protocol\_error\_cause IE "Message not compatible with BCC protocol state" including corresponding diagnostic.
- Postamble:  
LT1 sends an AN FAULT ACKNOWLEDGE message.  
BCC\_REL
- TP44\_\_S1\_04 Preamble: BCC\_FAULT  
(\*)  
On receipt of an AUDIT message, the IUT shall send a PROTOCOL ERROR message containing the protocol\_error\_cause IE "Message not compatible with BCC protocol state" including corresponding diagnostic.
- Postamble:  
LT1 sends an AN FAULT ACKNOWLEDGE message.  
BCC\_REL

### 5.5.5 Invalid behaviour tests (V5NWKAN/BCC/BI)

Refer to ETS 300 347-1 [2], subclause 17.5.8.

It is sufficient to perform these TPs for one the main features N11, N12 or M2 (see ETS 300 347-2 [3]).

Initial state of the IUT: BCC\_INIT  
Preamble: -  
Postamble: -

- TP45\_\_S0\_01 Check that the IUT discards messages having less than 4 octets.
- TP45\_\_S0\_02 (Protocol discriminator error)  
On receipt of an ALLOCATION message containing an unspecified protocol\_discriminator IE, the IUT shall send a PROTOCOL ERROR message containing the protocol\_error\_cause IE "Protocol discriminator error".
- TP45\_\_S0\_03 (Message type error)  
On receipt of a message containing an unspecified message\_type IE, the IUT shall send a PROTOCOL ERROR message containing the protocol\_error\_cause IE "Message type unrecognized" including corresponding diagnostic.
- TP45\_\_S0\_04 (Information element out of sequence)  
(note 2)  
On receipt of an ALLOCATION message containing unsorted IEs (V5\_TS\_ID IE before UP\_ID IE followed by ISDN\_port\_channel\_ID IE), the IUT shall send a PROTOCOL ERROR message containing the protocol\_error\_cause IE "Mandatory Information Element Missing" including corresponding diagnostic.
- TP45\_\_S0\_05 (Repeated mandatory information elements)  
On receipt of an ALLOCATION message containing a repeated UP\_ID IE followed by a V5\_TS\_ID IE, the IUT shall send a PROTOCOL ERROR message containing the protocol\_error\_cause IE "Repeated mandatory information element" including corresponding diagnostic.

TP45\_\_S0\_06      On receipt of an ALLOCATION message containing an UP\_ID IE and a repeated V5\_TS\_ID IE, the IUT shall send a PROTOCOL ERROR message including corresponding diagnostic and an ALLOCATION COMPLETE message.

Postamble: BCC\_REL

TP45\_\_S0\_07      (Mandatory information element missing)

On receipt of an ALLOCATION message containing no UP\_ID IE, the IUT shall send a PROTOCOL ERROR message containing the protocol\_error\_cause IE "Mandatory information element missing" including corresponding diagnostic.

TP45\_\_S0\_08      (Unrecognized information element)

On receipt of an ALLOCATION message containing an additional unspecified IE, the IUT shall send a PROTOCOL ERROR message containing the protocol\_error\_cause IE "Unrecognized information element" including corresponding diagnostic and an ALLOCATION COMPLETE message.

Postamble: BCC\_REL

TP45\_\_S0\_09      (Content error of mandatory information element)

On receipt of an ALLOCATION message containing an incorrect UP\_ID IE, the IUT shall send a PROTOCOL ERROR message containing the protocol\_error\_cause IE "Mandatory information element content error" including corresponding diagnostic.

TP45\_\_S0\_10      On receipt of an ALLOCATION message containing an incorrect  
(note 1) ISDN\_port\_channel\_ID IE, the IUT shall send a PROTOCOL ERROR message containing the protocol\_error\_cause IE "Mandatory information element content error" including corresponding diagnostic.

TP45\_\_S0\_11      On receipt of an ALLOCATION message containing an UP\_ID IE, a V5\_TS\_ID IE and  
(note 2) a multi-slot\_map IE, the IUT shall send a PROTOCOL ERROR message containing the protocol\_error\_cause IE "Too many information elements" including corresponding diagnostic.

TP45\_\_S0\_12      Preamble: BCC\_CONN

On receipt of an AUDIT message containing the UP\_ID IE and V5\_TS IE , the IUT shall send a PROTOCOL ERROR message containing the protocol\_error\_cause IE "Too many information elements" including corresponding diagnostic.

Postamble: BCC\_REL

NOTE 1:      These TPs are only applicable if PICS items N11 or N12 (see ETS 300 347-2 [3]) is set to yes.

NOTE 2:      These TPs are only applicable if PICS item N8 (see ETS 300 347-2 [3]) is set to yes.

### 5.5.6 Timer expiry and counter mismatch tests (V5NWKAN/BCC/TI)

Refer to ETS 300 347-1 [2], table 48.

Initial state of the IUT: BCC\_INIT  
Preamble: -  
Postamble: -

TP46\_\_S1\_01 Preamble: BCC\_FAULT  
(\* )

On time out of timer TBCC5, the IUT shall repeat sending the AN FAULT message.

On receipt of an AN FAULT ACKNOWLEDGE message after NBCC5 repetitions of the AN FAULT message, the IUT shall stop repeating the original message.

Postamble: BCC\_REL

TP46\_\_S1\_02 Preamble: BCC\_FAULT  
(\* )

On time out of timer TBCC5, the IUT shall repeat sending the AN FAULT message.

On NBCC5+1 time outs of timer TBCC5, the IUT shall stop repeating the original message.

Postamble: BCC\_REL

### 5.6 Protection protocol

This test group is only applicable if PICS item N9 (see ETS 300 347-2 [3]) is set to yes.

If not stated otherwise, the PROTECT messages sent by the IUT or LT1 shall have the following contents:

- a) the SN IE shall be set according to the rules of ETS 300 347-1 [2], subclause 18.6.2. The initial value of the SN IE shall be 0 at the beginning of each TP;
- b) the logical\_C-channel\_ID IE shall point on logical C-channel 2 (protection group 2);
- c) the physical\_C-channel\_ID IE shall point on TS 15 on the secondary link. If not stated otherwise, the SWITCH-OVER REQ message shall not contain a physical\_C-channel\_ID IE;
- d) all LINK CONTROL messages shall contain L3addr of the primary link.

Each PROTECT message sent by LT1 and IUT has to be broadcasted over TS 16 of the primary and secondary link with identical SN IEs. This has to be verified by LT1, but is not mentioned explicitly in the TPs.

Preambles given in a specific TP have to be applied after performing the global preamble, specific postambles have to be applied before performing the global postamble.

#### 5.6.1 Basic interconnection tests (V5NWKAN/PROTECT/IT)

Initial state of the IUT: PROTECT\_INIT  
Preamble: -  
Postamble: -

TP51\_\_SM\_01 Refer to TP11\_\_SM\_01, subclause 5.2.1

### 5.6.2 Capability tests (V5NWKAN/PROTECT/CA)

Refer to ETS 300 347-1 [2], table 65

Initial state of the IUT: PROTECT\_INIT  
Preamble: -  
Postamble: -

TP52\_\_S0\_01 "Sequence number reset initiated by LT1- normal procedure"

On receipt of a RESET SN COM message, the IUT shall send a RESET SN ACK message.

On receipt of a second RESET SN COM message, the IUT shall not send a RESET SN ACK message.

TP52\_\_S0\_02 "Sequence number reset initiated by IUT- normal procedure"

On receipt of a SWITCH-OVER COM message containing a SN IE = 5, the IUT shall send a RESET SN COM message.

On receipt of a RESET SN ACK message, the IUT shall not repeat the original message.

### 5.6.3 Valid behaviour tests (V5NWKAN/PROTECT/BV)

Refer to ETS 300 347-1 [2], table 65.

Initial state of the IUT: PROTECT\_INIT  
Preamble: PROTECT\_SOANx\_0  
Postamble: PROTECT\_SOANx\_0

TP53\_\_SM\_01 "Standard Switch-Over requested by LT1 - normal procedure"

On receipt of a SWITCH-OVER COM message, the IUT shall send a SWITCH-OVER ACK message.

Postamble: PROTECT\_BACK\_TO\_INIT2.

TP53\_\_SM\_02 "Dedicated OS-Switch-Over requested by LT1 - normal procedure without pre-emption"

On receipt of an OS-SWITCH-OVER COM message, the IUT shall send a SWITCH-OVER ACK message.

Postamble: PROTECT\_BACK\_TO\_INIT2.

TP53\_\_SM\_03 "Dedicated OS-Switch-Over requested by LT1 - normal procedure with pre-emption"

On receipt of an OS-SWITCH-OVER COM message containing the physical\_C-channel\_ID IE "TS 31 of primary link", the IUT shall send a SWITCH-OVER ACK message followed by a SWITCH-OVER REQ message containing the logical\_C-channel\_ID IE "3".

On receipt of an SWITCH-OVER COM message containing the physical\_C-channel\_ID IE "TS 15 of secondary link", the IUT shall send a SWITCH-OVER ACK message.

Postamble:  
STEP\_PR\_BACK\_TO\_INIT2  
STEP\_PR\_BACK\_TO\_INIT3



TP53\_\_SM\_04 "Switch-Over requested by IUT - normal procedure, failure of V5.2 secondary link"  
(\* )

Preamble:

Switch-over of logical C-channel "2" to the secondary link, timeslot 15.

On receipt of the trigger event "failure of V5.2 link", indicating a failure of the secondary link, the IUT shall send a SWITCH-OVER REQ message containing the logical\_C-channel\_ID IE "2".

On receipt of a SWITCH-OVER COM message containing the logical\_C-channel\_ID IE "2" and the physical\_C-channel\_ID IE "TS 15 of primary link", the IUT shall send a SWITCH-OVER ACK message containing the same data.

On receipt of a SWITCH-OVER COM message, the IUT shall send a SWITCH-OVER ACK message.

Postamble:

Disappearance of failure

TP53\_\_SM\_05 "Switch-Over requested by IUT - normal procedure, absence of flags"  
(\* )

On receipt of the trigger event "absence of flags", indicating a failure of TS 16 of the primary link, the IUT shall send a SWITCH-OVER REQ message containing the logical\_C-channel\_ID IE "1".

On receipt of a SWITCH-OVER COM message containing the logical\_C-channel\_ID IE "1" and the physical\_C-channel\_ID IE "TS 16 of secondary link", the IUT shall send a SWITCH-OVER ACK message containing the same data.

Postamble:

Disappearance of failure

PROTECT\_BACK\_TO\_INIT1.

TP53\_\_SM\_06 "Switch-Over requested by IUT - normal procedure, data link failure"  
(\* )

On receipt of the trigger event "data link failure", indicating a failure of TS 16 of the primary link, the IUT shall send a SWITCH-OVER REQ message containing the logical\_C-channel\_ID IE "1".

On receipt of a SWITCH-OVER COM message containing the logical\_C-channel\_ID IE "1" and the physical\_C-channel\_ID IE "TS 16 of secondary link", the IUT shall send a SWITCH-OVER ACK message containing the same data.

Postamble:

Disappearance of failure

PROTECT\_BACK\_TO\_INIT1

- TP53\_\_SM\_07 "Switch-Over requested by IUT - normal procedure, blocking of secondary link"
- Preamble:  
Switch-over of logical C-channel "2" to the secondary link, timeslot 15.
- On receipt of a LINK CONTROL message containing the link\_control\_function IE FE304 (link\_block\_cmd), the IUT shall send a SWITCH-OVER REQ message containing the logical\_C-channel\_ID IE "2".
- On receipt of a SWITCH-OVER COM message containing the logical\_C-channel\_ID IE "2" and the physical\_C-channel\_ID IE "TS 15 of primary link", the IUT shall send a SWITCH-OVER ACK message containing the same data.
- Postamble:  
LINK\_AN10\_20
- TP53\_\_SM\_08 "Standard Switch-Over requested by LT1 - exceptional procedure: target physical C-channel not operational".
- Preamble: LINK\_AN20\_10 for secondary link.
- On receipt of SWITCH-OVER COM message, the IUT shall send a SWITCH-OVER REJECT message containing the rejection\_cause\_type IE "target physical C-channel not operational".
- Postamble: LINK\_AN10\_20 for secondary link.
- TP53\_\_SM\_09 "Standard Switch-Over requested by LT1 - exceptional procedure: target physical C-channel not provisioned".
- On receipt of SWITCH-OVER COM message containing the physical\_C-channel\_ID IE "TS 31 of secondary link", the IUT shall send a SWITCH-OVER REJECT message containing the rejection\_cause\_type IE "target physical C-channel not provisioned".
- TP53\_\_SM\_10 "Standard Switch-Over requested by LT1 - exceptional procedure: protection group mismatch".
- On receipt of SWITCH-OVER COM message containing the logical\_C-channel\_ID IE "1" and the physical\_C-channel\_ID IE "TS 15 of secondary link", the IUT shall send a SWITCH-OVER REJECT message containing the rejection\_cause\_type IE "protection group mismatch".
- TP53\_\_SM\_11 "Standard Switch-Over requested by LT1 - exceptional procedure: requested allocation exists already".
- On receipt of SWITCH-OVER COM message containing the physical\_C-channel\_ID IE "TS 15 of primary link", the IUT shall send a SWITCH-OVER REJECT message containing the rejection\_cause\_type IE "requested allocation exists already".
- TP53\_\_SM\_12 (note) "Standard Switch-Over requested by LT1 - exceptional procedure: target physical C-channel already has logical C-channel".
- On receipt of SWITCH-OVER COM message containing the physical\_C-channel\_ID IE "TS 31 of primary link", the IUT shall send a SWITCH-OVER REJECT message containing the rejection\_cause\_type IE "target physical C-channel already has logical C-channel".

- TP53\_\_SM\_13 "Standard Switch-Over requested by LT1 - exceptional procedure: TSO4 running".
- Preamble:  
On receipt of a SWITCH-OVER COM message containing a SN IE = 5, the IUT shall send a RESET SN COM message.
- On receipt of a SWITCH-OVER COM message, the IUT shall ignore the message (send no response).
- Postamble:  
On receipt of a RESET SN ACK message, the IUT shall not repeat the original message.
- TP53\_\_SM\_14 "Dedicated OS-Switch-Over requested by LT1 - exceptional procedure: target physical C-channel not provisioned".
- On receipt of OS-SWITCH-OVER COM message containing the physical\_C-channel\_ID IE "TS 31 of secondary link", the IUT shall send a SWITCH-OVER REJECT message containing the rejection\_cause\_type IE "target physical C-channel not provisioned".
- TP53\_\_SM\_15 "Dedicated OS-Switch-Over requested by LT1 - exceptional procedure: protection group mismatch".
- On receipt of an OS-SWITCH-OVER COM message containing the physical\_C-channel\_ID IE "TS 16 of secondary link", the IUT shall send a SWITCH-OVER REJECT message containing the rejection\_cause\_type IE "protection group mismatch".
- TP53\_\_SM\_16 "Dedicated OS-Switch-Over requested by LT1 - exceptional procedure: requested allocation exists already".
- On receipt of OS-SWITCH-OVER COM message containing the physical\_C-channel\_ID IE "TS 15 of primary link", the IUT shall send a SWITCH-OVER REJECT message containing the rejection\_cause\_type IE "requested allocation exists already".
- TP53\_\_SM\_17 "Dedicated OS-Switch-Over requested by LT1 - exceptional procedure: TSO4 running".
- Preamble:  
On receipt of a SWITCH-OVER COM message containing a SN IE = 5, the IUT shall send a RESET SN COM message.
- On receipt of an OS-SWITCH-OVER COM message, the IUT shall ignore the message (send no response).
- Postamble:  
On receipt of a RESET SN ACK message, the IUT shall not repeat the original message.
- TP53\_\_SM\_18 "Switch-Over requested by IUT - exceptional procedure, LT1 reject switch-over"
- On receipt of a LINK CONTROL message containing the link\_control\_function IE FE304 (link\_block\_cmd), the IUT shall send a SWITCH-OVER REQ message containing the logical\_C-channel\_ID IE "1".
- On receipt of a SWITCH-OVER REJ message containing the logical\_C-channel\_ID IE "1", the physical\_C-channel\_ID IE "TS 16 of secondary link" and the rejection\_cause IE "target physical C-channel not operational", the IUT shall not repeat the original message.

TP53\_\_SM\_19 "Switch-Over requested by IUT - exceptional procedure, LT1 resets SN, TSO5 not running"

Preamble:

Switch-over of logical C-channel "2" to the secondary link, timeslot 15. On receipt of a LINK CONTROL message containing the link\_control\_function IE FE304 (link\_block\_cmd), the IUT shall send a SWITCH-OVER REQ message containing the logical\_C-channel\_ID IE "2".

On receipt of a RESET SN COM message the IUT shall send a RESET SN ACK and not repeat the SWITCH-OVER REQ message.

Postamble:

LINK\_AN10\_20, PROTECT\_BACK\_TO\_INIT2

TP53\_\_SM\_20

TP53\_\_SM\_21 "Switch-Over requested by IUT - exceptional procedure, LT1 sends RESET SN ACK"

Preamble:

Switch-over of logical C-channel "2" to the secondary link, timeslot 15. On receipt of a LINK CONTROL message containing the link\_control\_function IE FE304 (link\_block\_cmd), the IUT shall send a SWITCH-OVER REQ message containing the logical\_C-channel\_ID IE "2".

On receipt of a RESET SN ACK message, the IUT shall repeat the SWITCH-OVER REQ message with SN IE =1 (after time out of timer TSO3).

On receipt of a SWITCH-OVER COM message containing the logical\_C-channel\_ID IE "2" and the physical\_C-channel\_ID IE "TS 15 of primary link", the IUT shall send a SWITCH-OVER ACK message containing the same data.

Postamble:

LINK\_AN10\_20

TP53\_\_SM\_22 "Switch-Over requested by IUT - exceptional procedure, TO4 running"

Preamble:

Switch-over of logical C-channel "2" to the secondary link, timeslot 15

On receipt of a SWITCH-OVER COM message containing a SN IE = 5, the IUT shall send a RESET SN COM message.

On receipt of a LINK CONTROL message containing the link\_control\_function IE FE304 (link\_block\_cmd), no PROTECT message shall appear on the V5.2 interface.

On receipt of a RESET SN ACK message, the IUT shall send a SWITCH-OVER REQ message containing the logical\_C-channel\_ID IE "2".

On receipt of a SWITCH-OVER COM message containing the logical\_C-channel\_ID IE "2" and the physical\_C-channel\_ID IE "TS 15 of primary link", the IUT shall send a SWITCH-OVER ACK message containing the same data.

Postamble:

LINK\_AN10\_20

TP53\_\_SM\_23 "Checking upper boundary of SN"

On receipt of a SWITCH-OVER COM message containing the SN IE = 4, the IUT shall send a SWITCH-OVER ACK message.

Postamble: PROTECT\_BACK\_TO\_INIT2.

NOTE: These TPs are only applicable if at least two of the PICS items N11, N12 and M2 are set to yes (see ETS 300 347-2 [3]).

#### 5.6.4 Inopportune behaviour tests (V5NWKAN/PROTECT/BO)

Refer to ETS 300 347-1 [2], table 65.

Initial state of the IUT: PROTECT\_INIT  
Preamble: PROTECT\_SOANx\_0  
Postamble: PROTECT\_SOANx\_0

TP54\_\_S0\_01 On receipt of a SWITCH-OVER REJECT message, the IUT shall send PROTOCOL ERROR containing the protocol\_error\_cause IE "Message not compatible with protection protocol state" with corresponding diagnostic.

TP54\_\_S0\_02 On receipt of a RESET SN ACK message no message shall appear on the V5.2 interface.

TP54\_\_S0\_03 On receipt of a SWITCH-OVER ACK message, the IUT shall send a PROTOCOL ERROR message containing the protocol\_error\_cause IE "message type unrecognised" with corresponding diagnostic.

#### 5.6.5 Invalid behaviour tests (V5NWKAN/PROTECT/BI)

Refer to ETS 300 347-1 [2], subclause 18.5.

Initial state of the IUT: PROTECT\_INIT  
Preamble: PROTECT\_SOANx\_0  
Postamble: PROTECT\_SOANx\_0

TP55\_\_S0\_01 Check that the IUT discards messages having less than 4 octets.

TP55\_\_S0\_02 (Protocol discriminator error)

On receipt of a RESET SN COM message containing an unspecified protocol\_discriminator IE, the IUT shall send a PROTOCOL ERROR message containing the protocol\_error\_cause IE "protocol discriminator error".

TP55\_\_S0\_03 (Message type error)

On receipt of a message containing an unspecified message\_type IE, the IUT shall send a PROTOCOL ERROR message containing the protocol\_error\_cause IE "message type unrecognized" with corresponding diagnostic.

TP55\_\_S0\_04 (Repeated mandatory information elements)

On receipt of a RESET SN ACK message containing a repeated message\_type IE, the IUT shall send a PROTOCOL ERROR message containing the protocol\_error\_cause IE "Repeated mandatory information elements" with corresponding diagnostic.

TP55\_\_S0\_05 (Mandatory information element missing)

On receipt of a SWITCH-OVER COM message containing no Physical\_C-channel\_ID IE, the IUT shall send a PROTOCOL ERROR message containing the protocol\_error\_cause IE "Mandatory information element missing" with corresponding diagnostic.

TP55\_\_S0\_06 (Unrecognized information element)

On receipt of a RESET SN COM message containing an additional unspecified IE, the IUT shall send a PROTOCOL ERROR message containing the protocol\_error\_cause IE "Unrecognized information element" with corresponding diagnostic and a RESET SN ACK message.

TP55\_\_S0\_07 (Content error of mandatory information element - IE too long)

On receipt of a RESET SN COM message containing an incorrect Physical\_C-channel\_ID IE, the IUT shall send a PROTOCOL ERROR message containing the protocol\_error\_cause IE "Content error of mandatory information element" with corresponding diagnostic.

TP55\_\_S0\_08 (Detection of protocol error while TSO4 running)

Preamble:

On receipt of a SWITCH-OVER COM message containing a SN IE = 5, the IUT shall send a RESET SN COM message.

On receipt of a SWITCH-OVER REQ message containing an unspecified protocol\_discriminator IE, the IUT shall not send a PROTOCOL ERROR message or a SWITCH-OVER COM message.

Postamble:

On receipt of a RESET SN ACK message, the IUT shall not repeat the original message.

TP55\_\_S0\_09 (L3 address error)

On receipt of a RESET SN COM message containing an invalid L3 address, the IUT shall ignore the message.

TP55\_\_S0\_10 (Wrong information element identifier)

On receipt of a SWITCH OVER COM message containing an incorrect sequence\_number IEI (PSTN sequence number IEI) , the IUT shall send a PROTOCOL ERROR message containing the protocol\_error\_cause IE "Mandatory Information Element Missing" with corresponding diagnostic.

### 5.6.6 Timer expiry and counter mismatch tests (V5NWKAN/PROTECT/TI)

Refer to ETS 300 347-1 [2], table 25.

Initial state of the IUT: PROTECT\_INIT  
Preamble: PROTECT\_SOANx\_0  
Postamble: PROTECT\_SOANx\_0

TP56\_\_S0\_01 Preamble:  
On receipt of a SWITCH-OVER COM message containing a SN IE = 5, the IUT shall send a RESET SN COM message.

On time out of timer TSO4, the IUT shall repeat sending the RESET SN COM message.

On receipt of a RESET SN ACK message after NSO4 repetitions of the RESET SN COM message, the IUT shall stop repeating the original message.

TP56\_\_S0\_02 Preamble:  
On receipt of a SWITCH-OVER COM message containing a SN IE = 5, the IUT shall send a RESET SN COM message.

On time out of timer TSO4, the IUT shall repeat sending the RESET SN COM message.

On NSO4+1 time outs of timer TSO4, the IUT shall stop repeating the original message.

TP56\_\_S1\_03 Preamble:  
Switch-over of logical C-channel "2" to the secondary link, timeslot 15. On receipt of a LINK CONTROL message containing the link\_control\_function IE FE304 (link\_block\_cmd), the IUT shall send a SWITCH-OVER REQ message containing the logical\_C-channel\_ID IE "2".

On time out of timer TSO3, the IUT shall repeat sending the SWITCH-OVER REQ message.

On receipt of a SWITCH-OVER COM message containing the logical\_C-channel\_ID IE "2" and the physical\_C-channel\_ID IE "TS 15 of primary link" after NSO3 repetitions of the SWITCH-OVER REQ message, the IUT shall send a SWITCH-OVER ACK message containing the same data.

Postamble:  
LINK\_AN10\_20

TP56\_\_S1\_04 Preamble:  
On receipt of a LINK CONTROL message containing the link\_control\_function IE FE304 (link\_block\_cmd), the IUT shall send a SWITCH-OVER REQ message containing the logical\_C-channel\_ID IE "1".

On time out of timer TSO3, the IUT shall repeat sending the SWITCH-OVER REQ message.

On NSO3+1 time outs of timer TSO3, the IUT shall stop repeating the original message.

Postamble:  
LINK\_AN10\_20

TP56\_\_SM\_05

Preamble:

Switch-over of logical C-channel "2" to the secondary link, timeslot 15. On receipt of a LINK CONTROL message containing the link\_control\_function IE FE304 (link\_block\_cmd), the IUT shall send a SWITCH-OVER REQ message containing the logical\_C-channel\_ID IE "2".

On receipt of a SWITCH-OVER COM message containing a SN IE = 5, the IUT shall send a RESET SN COM message.

On receipt of a RESET SN ACK message, the IUT shall send a SWITCH-OVER REQ message containing the logical\_C-channel\_ID IE "2".

On receipt of a SWITCH-OVER COM message containing the logical\_C-channel\_ID IE "2" and the physical\_C-channel\_ID IE "TS 15 of primary link", the IUT shall send a SWITCH-OVER ACK message containing the same data.

Postamble:

LINK\_AN10\_20



**Annex A (informative): Bibliography**

- ETS 300 406: "Methods for Testing and Specification (MTS); Protocol and profile conformance testing specifications; Standardization methodology".

## History

Document history			
February 1996	First Edition		
December 1997	Public Enquiry	PE 9815:	1997-12-12 to 1998-04-10
January 1999	Vote	V 9912:	1999-01-19 to 1999-03-19