

**E**UROPEAN  
**T**ELECOMMUNICATION  
**S**TANDARD

**ETS 300 326-2**

January 1996

---

Source: ETSI TC-RES

Reference: DE/RES-5-01/12

ICS: 33.060.50

**Key words:** TFTS, radio interface

**Radio Equipment and Systems (RES);  
Terrestrial Flight Telephone System (TFTS);  
Part 2: Speech services, radio interface**

**ETSI**

European Telecommunications Standards Institute

**ETSI Secretariat**

**Postal address:** F-06921 Sophia Antipolis CEDEX - FRANCE

**Office address:** 650 Route des Lucioles - Sophia Antipolis - Valbonne - FRANCE

**X.400:** c=fr, a=atlas, p=etsi, s=secretariat - **Internet:** secretariat@etsi.fr

Tel.: +33 92 94 42 00 - Fax: +33 93 65 47 16

---

**Copyright Notification:** No part may be reproduced except as authorized by written permission. The copyright and the foregoing restriction extend to reproduction in all media.

© European Telecommunications Standards Institute 1996. All rights reserved.



## Contents

Foreword .....	15
1 Scope .....	17
2 Normative references .....	17
3 Abbreviations .....	19
4 Introduction to TFTS.....	22
4.1 General.....	22
4.2 Interface specification objectives.....	22
4.3 Interface characteristics .....	22
5 Protocol modelling principles .....	22
5.1 AS-GSS layering.....	23
6 TFTS user-to-network reference configuration.....	24
6.1 General.....	24
6.1.1 Reference configurations .....	24
6.1.2 Functional groups .....	24
6.1.3 Reference points.....	25
6.1.4 Terminal Equipment (TE) .....	25
6.2 TFTS reference configuration.....	25
6.3 Interfaces.....	27
7 Channel structures and access capabilities.....	27
7.1 General.....	27
7.2 Channel types and their use: Traffic Channels .....	27
7.3 Channel types and their use: Control channels.....	28
7.3.1 Logical control channel types.....	28
7.3.1.1 Broadcast Control CHannel (BCCH).....	28
7.3.1.2 Random Access CHannel (RACH).....	28
7.3.1.3 Initial Response Control CHannel (IRCCH).....	28
7.3.1.4 Radio Control CHannel (RCCH) .....	28
7.3.1.5 Dedicated Control CHannel (DCCH).....	28
7.4 GS Access capability .....	28
7.5 AS access capability .....	30
8 TFTS Radio Interface Layer 1 .....	31
8.1 Interfaces to the physical layer.....	31
8.1.1 Interface to layer 2.....	31
8.1.2 Interface to radio resource management.....	31
8.1.3 Interface to other functional units .....	31
8.2 Services of Layer 1 .....	31
8.2.1 Service Access Point (SAP) .....	32
8.2.2 Service provided .....	32
8.2.2.1 Specific services of layer 1 in the AS.....	32
8.3 Primitives of layer 1 .....	32
8.3.1 Generic names of primitives between layer 1 and layer 2 for the transfer of layer 2 frames.....	33
8.3.2 Generic names of primitives between layer 1 and the radio resource management entity of layer 3 .....	33
8.3.3 Primitive types .....	33
8.3.4 Parameter definition .....	33

8.4	Layer 1 procedures .....	35
8.4.1	States of layer 1.....	35
8.4.2	Remap procedure.....	35
8.4.2.1	Channel remap protocol .....	36
8.4.3	Layer 1 interface procedures.....	36
8.5	Layer 1 peer to peer exchanges.....	37
8.5.1	BCCH Synchronisation (S) transmission .....	37
8.5.2	Layer 1 radio control.....	37
8.5.3	Layer 1 random access procedures.....	37
8.5.4	Layer 1 channel access transaction .....	38
8.6	TDMA characteristics .....	38
8.6.1	General .....	38
8.6.2	Slot structure .....	39
8.6.2.1	General slot types .....	39
8.6.2.1.1	Field data .....	39
8.6.2.2	Synchronisation slot types .....	41
8.6.2.2.1	Field data .....	41
8.6.3	Functions of logical channels and mapping to physical channels.....	42
8.6.4	Timing requirements .....	47
8.6.5	Coding aspects .....	47
8.6.5.1	G1 Slot.....	47
8.6.5.2	G2 Slot.....	47
8.6.5.3	G3 Slot.....	47
8.6.5.4	Coding and interleaving of G2 and G3 slots .....	47
8.6.5.5	Coding of S1 slot.....	49
8.6.5.6	Coding of S2 slot.....	49
8.7	Modulation characteristics.....	49
8.7.1	General .....	49
8.7.1.1	Type of modulation .....	49
8.7.1.2	Channel transmission rate.....	50
8.7.1.3	Data clock stability.....	50
8.7.2	Modulator .....	50
8.7.2.1	Phase definition .....	50
8.7.2.2	Modulation filtering and modulated signal definition .....	51
8.7.2.3	Modulator and transmitter accuracy .....	53
8.7.2.3.1	Ideal case.....	53
8.7.2.3.2	Real case .....	53
8.7.2.4	Scrambler .....	54
8.8	Radio transmission and reception characteristics .....	55
8.8.1	General characteristics .....	55
8.8.1.1	Channelling.....	55
8.8.1.1.1	Frequency range .....	55
8.8.1.1.2	Radio frequency channel arrangement..	55
8.8.1.2	Channel selection time.....	55
8.8.1.3	Frequency stability.....	55
8.8.1.3.1	AS.....	55
8.8.1.3.2	GS.....	55
8.8.1.4	Modulation .....	56
8.8.2	Transmitter .....	56
8.8.2.1	Polarisation .....	56
8.8.2.2	Radiated power.....	56
8.8.2.2.1	AS.....	56
8.8.2.2.2	GS.....	56
8.8.2.2.2.1	En Route GS (ERGS).....	56
8.8.2.2.2.2	Intermediate GS (INTGS) .....	56
8.8.2.2.2.3	Airport GS (APGS).....	56
8.8.2.3	Power ramping procedure .....	56
8.8.2.4	RF spectrum mask.....	58
8.8.2.5	Out of band emissions.....	58
8.8.2.6	Spurious emissions .....	58

	8.8.2.7	Modulation accuracy .....	58	
8.8.3	Receiver .....		58	
	8.8.3.1	Frequency offsets .....	58	
	8.8.3.2	Static propagation conditions .....	59	
		8.8.3.2.1 Without interferer .....	59	
		8.8.3.2.2 With an interferer created by the intermodulation of two interfering signals .....	59	
		8.8.3.2.3 With adjacent interferer: TDM at the AS receiver and TDMA (uniform timeslot level) at the GS receiver .....	59	
		8.8.3.2.4 With co-channel TDMA interferer: variable timeslot level for GS receiver ..	60	
8.8.4	Dynamic propagation conditions .....		60	
		8.8.4.1 Basic BERs .....	60	
		8.8.4.2 BERs with interfering signals .....	61	
		8.8.4.3 GS receivers .....	61	
8.8.5	Propagation models .....		61	
	8.8.5.1	General .....	61	
	8.8.5.2	Doppler spectrum types .....	61	
	8.8.5.3	Models .....	62	
		8.8.5.3.1 Airport manoeuvring .....	62	
		8.8.5.3.2 Take-off .....	63	
		8.8.5.3.3 In-flight .....	63	
8.9	GS antenna characteristics .....		63	
	8.9.1	General .....	63	
	8.9.2	Common characteristics for all GS types .....	63	
		8.9.2.1 Frequency range .....	63	
		8.9.2.2 Polarisation .....	63	
		8.9.2.3 Energy acceptance capability .....	64	
	8.9.3	Specific characteristics for each type of GS .....	64	
		8.9.3.1 Radiation patterns .....	64	
			8.9.3.1.1 En route stations .....	64
			8.9.3.1.2 Intermediate stations .....	65
			8.9.3.1.3 Airport stations .....	65
		8.9.3.2 Antenna height .....	65	
8.10	Radio sub-system link control .....		65	
	8.10.1	General .....	65	
	8.10.2	Handover general .....	65	
		8.10.2.1 Overall process .....	65	
		8.10.2.2 Decision strategy for GS to GS handover .....	66	
			8.10.2.2.1 Primary handover decision .....	66
	8.10.3	R.F. power control .....	66	
		8.10.3.1 Purpose .....	66	
		8.10.3.2 Timing .....	66	
		8.10.3.3 Initial exchanges .....	66	
	8.10.4	RF power control at call initiation .....	66	
	8.10.5	Handover procedure .....	67	
	8.10.6	Cell selection and re-selection .....	68	
		8.10.6.1 Overall process .....	68	
		8.10.6.2 Reception of broadcast information .....	68	
		8.10.6.3 GS selection .....	68	
		8.10.6.4 Synchronisation .....	69	
		8.10.6.5 Negotiation .....	69	
	8.10.7	Network pre-requisites .....	69	
		8.10.7.1 BCCH .....	69	
			8.10.7.1.1 BCCH(S) .....	69
			8.10.7.1.2 BCCH(D) .....	69
		8.10.7.2 GS Handover .....	69	
8.10.8	Radio Link Measurements (RLM) .....		69	

	8.10.8.1	Signal strength.....	69
	8.10.8.2	Signal quality .....	69
		8.10.8.2.1 AS.....	70
		8.10.8.2.2 GS.....	70
		8.10.8.2.3 Range of parameter .....	70
	8.10.8.3	Absolute distance (AS only).....	70
		8.10.8.3.1 Range of parameter .....	70
	8.10.8.4	Radio Link Failure (RLF).....	70
	8.10.9	Timing control.....	70
	8.10.10	Control parameters.....	70
		8.10.10.1 Definition of network parameters.....	71
		8.10.10.2 Definition of Radio Resource (RR) parameters.....	72
		8.10.10.3 Definition of other parameters.....	72
		8.10.10.4 Calculation of range limit.....	73
8.11		Radio sub-system synchronisation .....	74
	8.11.1	Introduction.....	74
	8.11.2	GS synchronisation.....	74
	8.11.3	Cold Start Synchronisation (CSS) .....	74
		8.11.3.1 AS cold start requirements .....	74
		8.11.3.1.1 GS acquisition.....	74
		8.11.3.1.2 Transmitted S2 slot .....	74
		8.11.3.1.3 Received G3 slot.....	74
		8.11.3.1.4 Timing adjustment.....	75
		8.11.3.2 GS cold start requirements.....	75
		8.11.3.2.1 S2 reception .....	75
	8.11.4	Tracking procedure.....	75
		8.11.4.1 AS requirements.....	75
		8.11.4.2 GS requirements .....	75
	8.11.5	Warm Start Synchronisation (WSS) .....	75
		8.11.5.1 GS .....	75
		8.11.5.2 AS.....	75
9		TFTS radio interface layer 2.....	75
	9.1	General .....	76
	9.2	Layer 2 services.....	76
	9.3	Overview description of LAPDa functions and procedures .....	78
		9.3.1 General .....	78
		9.3.2 Unacknowledged operation .....	79
		9.3.3 Acknowledged operation.....	79
		9.3.4 Information transfer mode .....	80
		9.3.4.1 Information transfer on the BCCH.....	80
		9.3.4.2 Information transfer on the DCCHs.....	80
		9.3.5 Release of layer 2 .....	80
		9.3.6 Identification of layer 2 end points.....	80
	9.4	Service characteristics and requirements .....	81
		9.4.1 General requirements .....	81
		9.4.2 Services provided to layer 3.....	81
		9.4.2.1 General.....	81
		9.4.2.2 Priority .....	81
		9.4.2.3 Segmentation .....	81
		9.4.2.4 Unacknowledged information transfer service.....	81
		9.4.2.5 Acknowledged information transfer service .....	82
		9.4.3 Services required from the physical layer .....	83
		9.4.4 Administrative services.....	84
		9.4.4.1 General description of administrative services.....	84
		9.4.4.2 Definition of primitives for administrative services .....	84
	9.5	Overview of Layer 2 structure .....	84
		9.5.1 Functional composition .....	84
		9.5.2 Layer 2 procedure.....	85
	9.6	Layer 2 specification.....	85

9.6.1	General .....	85
9.6.2	Frame structure for peer-to-peer communication .....	86
9.6.2.1	General .....	86
9.6.2.2	Frame format .....	86
9.6.2.3	Frame delimitation .....	86
9.6.2.4	Header field .....	86
9.6.2.5	Information field.....	86
9.6.2.6	Fill field .....	86
9.6.2.7	Frame Check Sequence.....	87
9.6.2.8	Format convention .....	87
9.6.2.8.1	Numbering convention .....	87
9.6.2.8.2	Mapping to layer 1 message data.....	87
9.6.2.8.3	Field mapping convention .....	87
9.6.2.9	Invalid frames.....	88
9.6.3	Elements of procedure and formats of fields for data-link layer peer-to-peer communication.....	88
9.6.3.1	General .....	88
9.6.3.2	Header field format.....	88
9.6.3.3	Header field variables .....	89
9.6.3.3.1	Command/Response field bit (C/R) .....	89
9.6.3.3.2	Service Access Point Identifier.....	89
9.6.3.3.3	Length field .....	89
9.6.3.3.4	More data bit (M) .....	89
9.6.3.3.5	Control field.....	89
9.6.3.4	Control field formats .....	90
9.6.3.4.1	Information transfer (I) format.....	90
9.6.3.4.2	Supervisory (S) format.....	90
9.6.3.4.3	Unnumbered (U) format.....	90
9.6.3.5	Control field parameters and associated state variables ....	90
9.6.3.5.1	Poll/Final bit .....	90
9.6.3.5.2	Multiple frame operation, variables and sequence numbers.....	91
9.6.3.5.2.1	Modulus .....	91
9.6.3.5.2.2	Send state variable V(S) .....	91
9.6.3.5.2.3	Acknowledge state variable V(A) .....	91
9.6.3.5.2.4	Send sequence number N(S) .....	91
9.6.3.5.2.5	Receive state variable V(R).....	91
9.6.3.5.2.6	Receive sequence number N(R).....	91
9.6.3.5.3	Unacknowledged operation - variables and parameters ....	91
9.6.3.6	Frame types.....	92
9.6.3.6.1	Commands and responses .....	92
9.6.3.6.2	Information (I) commands.....	92
9.6.3.6.3	Set Asynchronous Balanced Mode (SABM) command .....	92
9.6.3.6.4	DISconnect (DISC) command.....	93
9.6.3.6.5	Unnumbered information (UI) command .....	93
9.6.3.6.6	Receive ready (RR) command/response .....	93
9.6.3.6.7	Reject (REJ) command/response.....	93
9.6.3.6.8	Receive not ready (RNR) command/response.....	94
9.6.3.6.9	Unnumbered Acknowledgement (UA) response.....	94
9.6.3.6.10	Disconnected Mode (DM) response .....	94
9.6.3.6.11	FRaMe Reject (FRMR) response.....	94
9.6.4	Elements for layer-to-layer communication .....	95
9.6.4.1	General .....	95
9.6.4.1.1	Generic names.....	95
9.6.4.1.1.1	DL-ESTABLISH.....	97
9.6.4.1.1.2	DL RELEASE.....	97
9.6.4.1.1.3	DL-DATA .....	97
9.6.4.1.1.4	DL-UNIT DATA.....	97
9.6.4.1.1.5	DL-SUSPEND .....	97
9.6.4.1.1.6	DL-RESUME .....	97

	9.6.4.1.1.7	Management Data Link (MDL)-RELEASE .....	98
	9.6.4.1.1.8	MDL-ERROR .....	98
	9.6.4.1.1.9	PH-DATA .....	98
	9.6.4.1.2	Primitive types .....	98
	9.6.4.1.3	Parameter definition .....	98
	9.6.4.1.3.1	Priority indicator .....	98
	9.6.4.1.3.2	Message unit .....	98
	9.6.4.1.3.3	Release mode .....	99
	9.6.4.1.3.4	Error cause .....	99
	9.6.4.1.3.5	Establish mode .....	99
	9.6.4.2	Primitive procedures .....	99
9.6.5		Definition of the peer-to-peer procedures of the data link layer .....	100
	9.6.5.1	General .....	100
	9.6.5.2	Procedure for the use of the P/F bit .....	100
	9.6.5.2.1	Unacknowledged information transfer .....	100
	9.6.5.2.2	Acknowledged multiple frame information transfer .....	100
	9.6.5.3	Procedures for unacknowledged information transfer .....	101
	9.6.5.3.1	General .....	101
	9.6.5.3.2	Transmission of unacknowledged information .....	101
	9.6.5.3.3	Receipt of unacknowledged information .....	101
	9.6.5.4	Procedures for establishment and release of multiple frame operation .....	101
	9.6.5.4.1	Establishment of multiple frame operation .....	101
	9.6.5.4.1.1	General .....	101
	9.6.5.4.1.2	Normal establishment procedures .....	102
	9.6.5.4.1.3	Procedure on expiry of timer T200: normal establishment .....	103
	9.6.5.4.1.4	Contention resolution establishment procedure .....	103
	9.6.5.4.1.5	Procedure on expiry of timer T200; contention resolution (AS only) .....	105
	9.6.5.4.2	Information transfer .....	105
	9.6.5.4.2.1	General requirements .....	105
	9.6.5.4.2.2	Error conditions .....	105
	9.6.5.4.2.3	Fill frames .....	106
	9.6.5.4.3	Suspension and resumption of multiple frame operation .....	106
	9.6.5.4.3.1	General .....	106
	9.6.5.4.3.2	Suspension .....	106
	9.6.5.4.4	Resumption of multiple frame operation .....	107
	9.6.5.4.4.1	Procedure on expiry of timer T200 .....	107
	9.6.5.4.5	Termination of multiple frame operation .....	108
	9.6.5.4.5.1	General .....	108
	9.6.5.4.5.2	Normal release procedure .....	108
	9.6.5.4.5.3	Procedure on expiry of timer T200 for normal release .....	108
	9.6.5.4.5.4	Local end release procedure .....	109
	9.6.5.4.6	Idle state .....	109
	9.6.5.4.7	Collision of unnumbered commands and responses .....	110
	9.6.5.4.7.1	Identical transmitted and received commands .....	110
	9.6.5.4.7.2	Different transmitted and received commands .....	110
	9.6.5.4.7.3	Unsolicited DM response and SABM or DISC command .....	110
	9.6.5.5	Procedures for information transfer in multiple frame operation .....	110
	9.6.5.5.1	Transmitting I frames .....	110
	9.6.5.5.2	Receiving I frames .....	111
	9.6.5.5.2.1	P bit set to "1" .....	111
	9.6.5.5.2.2	P bit set to "0" .....	111
	9.6.5.5.3	Receiving acknowledgement .....	112
	9.6.5.5.4	Receiving REJ frames .....	112
	9.6.5.5.4.1	Transmitting I frames .....	113
	9.6.5.5.4.2	Response to supervisory command frames .....	113
	9.6.5.5.5	Receiving RNR frames .....	113
	9.6.5.5.6	Data link layer own receiver busy condition .....	115



	9.6.5.5.7	Waiting acknowledgement.....	115
	9.6.5.6	Abnormal release and re-establishment of multiple frame operation .....	116
	9.6.5.6.1	Criteria for re-establishment .....	116
	9.6.5.6.2	Criteria for abnormal release .....	116
	9.6.5.6.3	Procedures for re-establishment.....	116
	9.6.5.6.4	Procedures for abnormal release.....	116
	9.6.5.7	Exception condition reporting and recovery for multiple frame operation.....	117
	9.6.5.7.1	N(S) sequence error .....	117
	9.6.5.7.2	N(R) sequence error .....	117
	9.6.5.7.3	Timer recovery .....	117
	9.6.5.7.4	Invalid frame condition.....	118
	9.6.5.7.5	Frame rejection condition .....	118
	9.6.5.7.6	Receipt of an FRMR response frame .....	118
	9.6.5.7.7	Radio link failure condition .....	118
	9.6.5.8	List of system parameters.....	118
	9.6.5.8.1	Timer T200 .....	118
	9.6.5.8.2	Maximum number of re-transmissions (N200).....	118
	9.6.5.8.3	Maximum number of octets in an information field (N201).....	118
	9.6.5.8.4	Number of octets in a frame (N202) .....	119
	9.6.5.8.5	Maximum number of octets in a message unit parameter (N203).....	119
	9.6.5.8.6	Maximum number of outstanding I frames (k).....	119
10	AS - GSS layer 3 specification .....		119
	10.1	Introduction.....	119
	10.1.1	General .....	119
	10.1.2	Objectives .....	119
	10.1.3	General characteristics.....	119
	10.1.3.1	Technique of description.....	119
	10.1.3.2	Primitives .....	120
	10.1.3.3	Peer-to-peer communication.....	120
	10.2	Structure of signalling functions .....	120
	10.2.1	Basic groups of functions .....	120
	10.2.2	Protocol architecture .....	120
	10.3	Services provided by signalling layer 3 on the AS side.....	122
	10.3.1	CC services .....	122
	10.3.1.1	General .....	122
	10.3.1.2	Service state diagram .....	122
	10.3.1.3	Service primitives.....	123
	10.4	Services provided by signalling layer 3 on the GSS side.....	124
	10.4.1	CC services .....	124
	10.4.1.1	General .....	124
	10.4.1.2	Service state diagram .....	124
	10.4.1.3	Service primitives.....	125
	10.5	Services assumed from signalling layer 2 .....	126
	10.5.1	General .....	126
	10.5.2	Service primitives .....	126
	10.5.2.1	Unacknowledged information transfer.....	126
	10.5.2.2	Acknowledged information transfer .....	127
	10.6	Inter-layer service interfaces on the AS side.....	127
	10.6.1	Services provided by the RRM entity .....	127
	10.6.1.1	General .....	127
	10.6.1.2	Service state diagram .....	128
	10.6.1.3	Service primitives.....	129
	10.7	Inter-layer service interfaces on the GS side .....	130
	10.7.1	Services provided by the RRM entity .....	130
	10.7.1.1	General .....	130
	10.7.1.2	Service state diagram .....	131

	10.7.1.3	Service primitives.....	132
10.8		Service assumed from layer 1 .....	133
	10.8.1	General .....	133
	10.8.2	Service primitives .....	133
10.9		Functions provided by layer 3 entities.....	133
	10.9.1	Functions provided by the RRM entity .....	133
	10.9.2	Functions provided by the CC management entity .....	133
	10.9.3	Functions provided by the distribution entity .....	133
	10.9.4	Functions provided by the MR entity.....	134
10.10		Call setup examples .....	134
10.11		Radio interface layer 3 specification.....	135
	10.11.1	General .....	135
	10.11.1.1	Scope of the specification.....	135
	10.11.1.2	Application to the interface structure.....	135
	10.11.1.3	Structure of the layer 3 procedures .....	136
	10.11.1.4	Test procedures .....	136
	10.11.1.5	Use of logical channels.....	136
	10.11.2	Overview of control procedures .....	136
	10.11.2.1	List of procedures.....	136
	10.11.2.2	Procedure for contention resolution .....	136
	10.11.2.3	General recovery procedures .....	137
	10.11.2.3.1	Normal message flow .....	137
	10.11.2.3.2	Expiry of the request timer T .....	137
	10.11.2.3.3	Change of dedicated channels using SAPI=0.....	137
	10.11.2.4	Sequenced message transfer operation.....	137
	10.11.2.4.1	Variables and sequence numbers .....	138
	10.11.2.4.1.1	Send state variable V(SD).....	138
	10.11.2.4.1.2	Send sequence number N(SD).....	138
	10.11.2.4.2	Procedure for the setting, transfer and termination of sequenced message transfer.....	138
	10.11.2.4.2.1	Setting.....	138
	10.11.2.4.2.2	Transfer.....	138
	10.11.2.4.2.3	Termination.....	138
10.11.3		Elementary procedures for RRM .....	138
	10.11.3.1	Overview.....	138
	10.11.3.1.1	General .....	138
	10.11.3.1.2	Service provided to upper layers.....	139
	10.11.3.1.2.1	The null state .....	139
	10.11.3.1.2.2	Services provided in idle mode .....	139
	10.11.3.1.2.3	Establishment and release of an RR- connection .....	139
	10.11.3.1.2.4	Service provided in RR connected mode.....	139
	10.11.3.1.3	Service required from data link and physical layers .....	139
	10.11.3.1.4	Terminology .....	140
	10.11.3.2	System management procedures.....	140
	10.11.3.2.1	BCCH (D) data acquisition (AS side)..	140
	10.11.3.2.2	Other system data acquisition (AS side).....	140
	10.11.3.2.3	Broadcast system information (GS side).....	140
	10.11.3.3	Paging procedures.....	142
	10.11.3.3.1	Paging of a subscriber .....	142
	10.11.3.3.1.1	Initiation of the PAGE .....	142
	10.11.3.3.1.2	Broadcast duration for paging.....	142
	10.11.3.3.1.3	PAGE response .....	142
	10.11.3.3.1.4	Release of the connection.....	142

	10.11.3.3.1.5	Abnormal cases .....	142
	10.11.3.3.2	Engineering paging (ENGPAGE).....	142
	10.11.3.3.2.1	Initiation of the ENGPAGE .....	142
	10.11.3.3.2.2	Broadcast duration for ENGPAGE.....	142
	10.11.3.3.2.3	ENGPAGE response .....	143
	10.11.3.3.2.4	Release of the connection.....	143
	10.11.3.3.2.5	Abnormal cases .....	143
	10.11.3.3.3	Group broadcast.....	143
	10.11.3.3.3.1	Network functionality.....	143
	10.11.3.3.3.2	AS functionality .....	143
	10.11.3.3.3.3	Broadcast data repeat length .....	143
10.11.3.4		RR connection establishment initiated by the AS .....	143
	10.11.3.4.1	Request for resources by the AS.....	143
	10.11.3.4.2	Answer from the GS.....	144
	10.11.3.4.3	Negotiation process.....	144
	10.11.3.4.4	Assignment completion .....	145
	10.11.3.4.5	Abnormal cases .....	145
	10.11.3.4.6	Remap Procedure for radio resource establishment.....	145
10.11.3.5		RR-connection transfer phase.....	145
	10.11.3.5.1	Transfer of messages.....	145
	10.11.3.5.2	Handover procedure .....	145
	10.11.3.5.2.1	Handover procedures on GS side .....	146
	10.11.3.5.2.2	Handover procedures on AS side.....	147
	10.11.3.5.2.3	Allocation of the new resources to the used Ba, Ma, La channels.....	147
	10.11.3.5.2.4	Physical channel and data link establishment.....	147
	10.11.3.5.2.5	Handover completion .....	148
	10.11.3.5.2.6	Abnormal cases .....	148
	10.11.3.5.3	Additional channel assignment .....	148
	10.11.3.5.3.1	Additional assignment procedure initiation .....	148
	10.11.3.5.3.2	Additional assignment completion .....	149
	10.11.3.5.3.3	Abnormal cases .....	149
	10.11.3.5.4	Release of assigned channels .....	149
	10.11.3.5.4.1	Release initiation of assigned channels	149
	10.11.3.5.4.2	Abnormal cases .....	149
10.11.3.6		RR-connection release.....	149
	10.11.3.6.1	Normal release.....	150
	10.11.3.6.1.1	Channel release termination .....	150
	10.11.3.6.1.2	Abnormal cases .....	150
10.11.3.7		Alternative procedure .....	150
	10.11.3.7.1	General .....	150
	10.11.3.7.1.1	Channel release initiation.....	150
	10.11.3.7.1.2	Additional signalling from the maintenance resource entity.....	151
	10.11.3.7.1.3	New set-up of a call or paging resources .....	151
	10.11.3.7.1.4	Channel release termination .....	151
	10.11.3.7.1.5	Abnormal cases .....	151
	10.11.3.7.2	Radio link failure.....	151
	10.11.3.7.2.1	AS side .....	152
	10.11.3.7.2.2	GS side.....	152
	10.11.3.7.3	Ground network failure .....	152
	10.11.3.7.4	Remap failure .....	152
	10.11.3.7.5	Remap interruption.....	152
10.11.4		Elementary procedures for circuit-switched CC.....	152
	10.11.4.1	Overview .....	152
	10.11.4.1.1	General.....	152

	10.11.4.1.2	CC states .....	155
	10.11.4.1.2.1	Call states at the AS side of the interface .....	155
	10.11.4.1.2.2	Call states at the GSS side of the interface .....	155
	10.11.4.1.3	Circuit-switched CC procedures.....	156
10.11.4.2		Aircraft originating call establishment procedures .....	156
	10.11.4.2.1	General .....	156
	10.11.4.2.2	Call request .....	156
	10.11.4.2.3	Invalid call information.....	157
	10.11.4.2.4	Call proceeding .....	157
	10.11.4.2.5	Notification of interworking in connection with call establishment.....	158
	10.11.4.2.6	Call confirmation indication .....	158
	10.11.4.2.7	Call connected .....	158
	10.11.4.2.8	Call rejection .....	159
10.11.4.3		Signalling procedures during the active state .....	159
	10.11.4.3.1	User notification procedure.....	159
	10.11.4.3.2	Call rearrangements .....	159
	10.11.4.3.3	Dual Tone Multi-Frequency protocol control procedure .....	159
	10.11.4.3.3.1	Send DTMF request by the AS.....	159
	10.11.4.3.3.2	Send DTMF response by the network	160
	10.11.4.3.3.3	Sequencing of subsequent send DTMF requests by the AS.....	160
10.11.4.4		Call clearing .....	160
	10.11.4.4.1	Terminology .....	160
	10.11.4.4.2	Exception conditions .....	161
	10.11.4.4.3	Clearing initiated by the AS .....	161
	10.11.4.4.4	Clearing initiated by the GSS.....	162
	10.11.4.4.4.1	Clearing when tones/announcements provided .....	162
	10.11.4.4.4.2	Clearing when tones/announcements not provided.....	162
	10.11.4.4.4.3	Completion of clearing .....	163
	10.11.4.4.5	Clear collision.....	163
10.11.4.5		Miscellaneous procedures .....	164
	10.11.4.5.1	In-band tones and announcements.....	164
	10.11.4.5.2	Status procedures .....	164
	10.11.4.5.2.1	Status enquiry procedure .....	164
	10.11.4.5.2.2	Receiving a STATUS message by a CC-entity .....	165
10.11.5		Elementary procedures for maintenance resource management.....	165
	10.11.5.1	Overview.....	165
	10.11.5.1.1	General .....	165
10.11.5.2		GSS originated signalling procedures .....	165
	10.11.5.2.1	General .....	165
	10.11.5.2.2	Paging.....	166
	10.11.5.2.3	Engineering paging .....	167
	10.11.5.2.4	Shutdown.....	168
	10.11.5.2.5	Operation and Maintenance (OM).....	168
	10.11.5.2.5.1	General .....	168
	10.11.5.2.5.2	Transmission of OM data with high priority.....	169
10.11.6		Handling of error conditions .....	171
	10.11.6.1	General.....	171
	10.11.6.2	Protocol discrimination error .....	172
	10.11.6.3	Message too short.....	172
	10.11.6.4	Transaction identifier error.....	172
	10.11.6.4.1	Call control.....	172

	10.11.6.4.2	Radio resource .....	172
	10.11.6.4.3	MR.....	172
10.11.6.5	Message type error .....		172
	10.11.6.5.1	Call control .....	172
	10.11.6.5.2	Radio resource .....	172
	10.11.6.5.3	MR.....	173
10.11.6.6	General information elements errors .....		173
	10.11.6.6.1	Information element out of sequence..	173
	10.11.6.6.2	Duplicated information element.....	173
10.11.6.7	Mandatory information element error.....		173
	10.11.6.7.1	Call control .....	173
	10.11.6.7.2	Radio resource .....	174
10.11.6.8	Non-mandatory information element errors .....		174
	10.11.6.8.1	Unrecognized information element.....	174
	10.11.6.8.2	Non-mandatory information element content error.....	175
	10.11.6.8.2.1	Call control .....	175
10.11.7	Message functional definitions and contents .....		175
10.11.7.1	Messages for RRM .....		175
	10.11.7.1.1	Establish request.....	176
	10.11.7.1.2	Establish confirm.....	176
	10.11.7.1.3	Establish reject .....	177
	10.11.7.1.4	Handover command.....	177
	10.11.7.1.5	Handover request.....	177
	10.11.7.1.6	Handover reject.....	178
	10.11.7.1.7	Resource release request.....	178
	10.11.7.1.8	Resource release confirm .....	178
	10.11.7.1.9	Resource abort request .....	179
	10.11.7.1.10	Resource abort confirm .....	179
	10.11.7.1.11	Identity indication.....	179
	10.11.7.1.12	Handover failure .....	180
	10.11.7.1.13	Handover complete.....	180
	10.11.7.1.13a	Group broadcast data transfer .....	180
	10.11.7.1.14	System Information type 1 .....	180
	10.11.7.1.15	System Information type 2 .....	181
	10.11.7.1.16	System Information type 3 .....	181
	10.11.7.1.17	System Information type 4 .....	181
	10.11.7.1.18	System Information type 5 .....	182
	10.11.7.1.19	System Information type 6 .....	182
	10.11.7.1.20	System Information type 7 .....	182
	10.11.7.1.21	System Information type 8 .....	183
	10.11.7.1.21a	System Information type 9 .....	183
	10.11.7.1.22	Status .....	184
10.11.7.2	Messages for circuit-mode connections CC .....		184
	10.11.7.2.1	Alerting.....	185
	10.11.7.2.2	Call proceeding .....	185
	10.11.7.2.3	Connect.....	186
	10.11.7.2.4	Disconnect.....	186
	10.11.7.2.5	Notify .....	187
	10.11.7.2.6	Progress .....	187
	10.11.7.2.7	Release.....	187
	10.11.7.2.8	Release complete .....	188
	10.11.7.2.9	Setup .....	189
	10.11.7.2.10	Send DTMF.....	190
	10.11.7.2.11	Send DTMF acknowledge.....	190
	10.11.7.2.12	Send DTMF reject.....	191
	10.11.7.2.13	Status .....	191
	10.11.7.2.14	Status enquiry.....	191
10.11.7.3	Messages for MR management.....		191
	10.11.7.3.1	ENGPAGE channel response .....	192

	10.11.7.3.2	ENGPAGE data transfer.....	192
	10.11.7.3.3	ENGPAGE channel release.....	193
	10.11.7.3.4	OM data transfer.....	193
	10.11.7.3.5	PAGE channel response .....	193
	10.11.7.3.6	PAGE data transfer.....	194
	10.11.7.3.7	PAGE channel release.....	194
	10.11.7.3.8	Status.....	194
10.11.8		General message format and information elements coding .....	194
	10.11.8.1	Overview.....	195
	10.11.8.2	Protocol discriminator.....	195
	10.11.8.3	Transaction identifier .....	196
	10.11.8.4	Message type .....	197
	10.11.8.5	Other information elements.....	198
	10.11.8.5.1	Common information elements.....	202
	10.11.8.5.2	Radio resource management information elements.....	202
	10.11.8.5.2.1	Aircraft Terminations Equipment Identity .....	203
	10.11.8.5.2.2	RR cause.....	204
	10.11.8.5.2.3	Cell management parameters.....	205
	10.11.8.5.2.4	Engineering page.....	208
	10.11.8.5.2.5	En-route (ER) - primary frequencies...	208
	10.11.8.5.2.6	Page .....	209
	10.11.8.5.2.7	Primary frequencies.....	209
	10.11.8.5.2.8	Radio channel number.....	210
	10.11.8.5.2.9	Resource request.....	211
	10.11.8.5.3	Call control information elements .....	221
	10.11.8.5.3.1	Aircraft information .....	222
	10.11.8.5.3.2	Bearer capability .....	222
	10.11.8.5.3.3	Call state .....	223
	10.11.8.5.3.4	Called party BCD number.....	225
	10.11.8.5.3.5	Called party subaddress .....	227
	10.11.8.5.3.6	Cause.....	229
	10.11.8.5.3.7	Credit card information.....	234
	10.11.8.5.3.8	High layer compatibility .....	234
	10.11.8.5.3.9	Keypad facility.....	235
	10.11.8.5.4	MR information elements.....	238
	10.11	8.5.4.1 ENG channel reference.....	239
	10.11.8.5.4.2	Aircraft Terminations Equipment Identifier .....	239
	10.11.8.5.4.3	Data information.....	239
	10.11.8.5.4.4	PAGE channel reference.....	240
	10.11.8.5.4.5	MR-cause.....	241
10.11.9		List of system parameters.....	242
	10.11.9.1	Timers of circuit-switched CC .....	242
	10.11.9.2	Timers and counters for RRM.....	243
	10.11.9.2.1	Timers on the GS side .....	243
	10.11.9.2.2	Timers on the AS side.....	244
	10.11.9.2.3	Counters on the AS side .....	244
	10.11.9.2.4	Counters on the GS side.....	244
	10.11.9.3	Timer values for MR management.....	244
	10.11.9.3.1	Timer values on AS side.....	244
	10.11.9.3.2	Timer values on GS side.....	245
10.11.10		Definition of primitive parameters.....	245
10.11.11		SDL of TFTS layer 3 processes .....	247
History		.....	307

## Foreword

This European Telecommunication Standard (ETS) has been produced by the Radio Equipment and Systems (RES) Technical Committee of the European Telecommunications Standards Institute (ETSI).

The Terrestrial-Flight Telecommunications System (TFTS) Aircraft Station (AS) was specified by the European Airlines Electronics Committee (EAEC) and has subsequently been adopted as Aeronautical Radio Incorporated (ARINC) Characteristic 752 [2] by the Airlines Electronic Engineering Committee (AEEC).

ARINC Specification 752 [2] makes reference to this ETS for the specification of certain radio and telecommunication matters to avoid ambiguity. The TFTS AS is one of a set of facilities within an overall architecture being defined for aircraft on board telecommunications by the AEEC.

This ETS has been split into three parts as follows:

Part 1: "Speech services, facilities and requirements";

**Part 2: "Radio interface";**

Part 3: "Network aspects".

An ETSI Technical Report (ETR) is in preparation for those manufacturers and/or system operators who require a defined interface between the TFTS Ground Station (GS) and TFTS Ground Switching Centre (GSC).

Transposition dates	
Date of adoption of this ETS:	26 May 1995
Date of latest announcement of this ETS (doa):	28 February 1996
Date of latest publication of new National Standard or endorsement of this ETS (dop/e):	31 August 1996
Date of withdrawal of any conflicting National Standard (dow):	31 August 1996

Blank page



## 1 Scope

This European Telecommunication Standard (ETS) specifies the minimum technical requirements of the radio interface that the TFTS shall support to provide a panEuropean terrestrial aeronautical public correspondence service.

This ETS contains the specification of equipment for the provision of a terrestrial aeronautical public correspondence service working in the frequency spectrum bands allocated at the World Administrations Radio Conference 1992 (WARC 92) (1 670 - 1 675 MHz and 1 800 - 1 805 MHz).

This ETS fully specifies aspects of the radio interface and Terrestrial Flight Telephone System (TFTS) ground network required to maintain inter-operability of equipment. ERC Decision ERC/DEC (92)01 [1] is applicable to the TFTS frequency spectrum within Europe.

An I-ETS is being prepared which covers aspects of conformance testing for TFTS aircraft mobile stations.

The specification of data application and facsimile will be the subject of a further I-ETS.

## 2 Normative references

This ETS incorporates by dated or undated reference, provisions from other publications. These normative references are cited at the appropriate places in the text and the publications listed hereafter. For dated references, subsequent amendments to or revisions of any of these publications apply to this ETS only when incorporated in it by amendment or revision. For undated references the latest edition of the publication applies.

- [1] ERC Decision ERC/DEC (92)01: "Definition of frequency bands for the Pan European terrestrial flight telephone system (TFTS)".
- [2] ARINC Characteristic 752: "Terrestrial Flight Telephone System (TFTS) Airborne Radio Sub-system".
- [3] CCITT Recommendation X.200 (1988): "Reference model of open system interconnection for CCITT applications".
- [4] CCITT Recommendation X.210 (1988): "Open systems interconnection layer service definition".
- [5] ARINC Characteristic 746: "Cabin Communications System".
- [6] CCITT Recommendation I.411 (1988): "ISDN user-network interfaces - Reference configurations".
- [7] CCITT Recommendation X-series
- [8] CCITT Recommendation V-series
- [9] CCITT Recommendation I.420 (1988): "Basic user-network interface".
- [10] CCITT Recommendation I.450 (1988): "ISDN user-network interface layer 3 - General aspects".
- [11] ETS 300 326-3 (1995): "Radio Equipment and Systems (RES); Terrestrial Flight Telecommunication System (TFTS); Part 3: Speech services, network aspects".
- [12] ETS 300 326-1 (1995): "Radio Equipment and Systems (RES); Terrestrial Flight Telecommunication System (TFTS) Part 1: Speech services, facilities and requirements".

- [13] CCITT Recommendation Q.920 (1988): "ISDN user-network interface data link layer - General aspects".
- [14] CCITT Recommendation Q.921 (1988): "ISDN user-network interface - Data link layer specification".
- [15] GSM Technical Specification 04.05: "MS-BSS Datalink Layer - General aspects".
- [16] GSM Technical Specification 04.06: "MS-BSS Interface Data Link Layer specification".
- [17] CCITT Recommendation Z.100 (1988): "Specification and description language (SDL)".
- [18] CCITT Recommendation Q.23 (1988): "Technical features of push-button telephone sets".
- [19] CEPT Recommendation T/CS 46-02: "Multi-frequency signalling system to be used for push-button telephones".
- [20] CEPT Recommendation T/CS 34-08: "Automatic sender for push-button multi-frequency signalling".
- [21] CCITT Recommendation Q.931 (1988): "ISDN user-network interface layer 3 specification for basic call control".
- [22] CCITT Recommendation I.330 (1988): "ISDN numbering and addressing principles".
- [23] CCITT Recommendation E.164 (1988): "Numbering plan for the ISDN era".
- [24] CCITT Recommendation I.332 (1988): "Numbering principles for underwriting between ISDNs and dedicated networks with different numbering plans".
- [25] ISO 7813: "Identification cards - Financial transaction cards".
- [26] CCITT Recommendation E.163: "Numbering plan for the international telephone service".
- [27] CCITT Recommendation X.121: "International numbering plan for public data networks".
- [28] CCITT Recommendation F.69: "Plan for telex destination codes".
- [29] CCITT Recommendation X.213: "Network service definition for open systems interconnection for CCITT applications".
- [30] ISO 8348 AD2 (1987): "Information processing systems - Data communications - Network service definition Addendum 2: Network layer addressing".
- [31] CCITT Recommendation X.21: "Interface between data terminal equipment (DTE) and data circuit-terminating equipment (DCE) for synchronous operation on public data networks".
- [32] CCITT Recommendation X.25: "Interface between data terminal equipment (DTE) and data circuit-terminating equipment (DCE) for terminals operating in the packet mode and connected to public data networks by dedicated circuit".

- [33] ARINC Characteristic 741: "Aviation satellite Communications System, Parts 1 to 4".
- [34] Inmarsat Aeronautical Satellite System Definition Manual
- [35] ETS 300 086: "Radio Equipment and Systems (RES); Land mobile group; Technical characteristics and test conditions for radio equipment with an internal or external RF connector intended primarily for analogue speech".
- [36] "International Civil Aviation Organisation (ICAO) International Standards, recommended practices and procedures for air navigation services".
- [37] "Aeronautical Telecommunications Annex 10 to the convention on International Civil Aviation, Volume 1, Part 1 (Equipment and Systems, Part 2, Radio Frequencies, Fourth edition of Volume 1 April 1985".
- [38] "ATA/IATA Interline Communications Manual (Doc. GEN/1840, Revision 8)".
- [39] "IATA Reservations Interline Message Procedures - Passenger Manual".

### 3 Abbreviations

For the purposes of this ETS the following abbreviations apply:

AC	Administration Centre
AEC	Aircraft Equipment Code
AEEC	Airlines Electronic Engineering Committee
AEN	Aircraft Equipment Number
ALT	Altitude
ALTREF	REfERENCE ALTitude
AP	Airport
APC	Aeronautical Public Correspondence
APGS	AirPort Ground Stations
ARINC	Aeronautical Radio INCorporated
AS	Aircraft Station
ASI	Aircraft Station Identity
AT	Avionics Termination
ATE	Airborne Telecommunications Equipment
ATEI	Aircraft Termination Equipment Identifier
ATISDN	Aircraft Termination ISDN
BC	Bearer Capability
BCCH	Broadcast Control Channel
BER	Bit Error Ratio
C/No	Carrier / Noise density
CC	Country Control
CCITT	Consultative Committee on International Telegraphy and Telephony
CCM	Call Control Management
CEPT	European Conference of Postal and Telecommunications Administrations
CM	Connection Management
CR	Closing Rate
C/R	Command/Response
CS	Cabin Systems
CSS	Cold Start Synchronization
DCCH	Dedicated Control Channel
DISC	DISConnect
DLCI	Data Link Connection Indicator
DM	Disconnected Mode
DT	Data Transfer
DTMF	Dual Tone Multi-Frequency
EAEC	European Airlines Electronics Committee

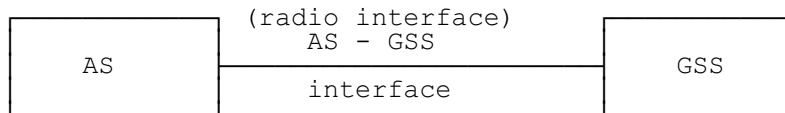
EIRP	Equivalent Isotropic Radiated Power
ER	En-Route
ERPRIFREQ	En-Route PRImary FREQency
ERC	European Radio Committee
ERGS	En-Route Ground Stations
FAC	Final Assembly Code
FACCH	Fast Associated Control Channel
FCS	Frame Check Sequence
FEC	Forward Error Correction
FRMR	FRaMe Reject
GCC	Ground switching Centre Code
GCT	Ground station Cell Type
GEN	Ground station Equipment Number
GN	Ground Network
GS	Ground Station
GSC	Ground Switching Centre
GSIC	Ground Station Identity Code
GSLAT	Ground Station Latitude
GSLONG	Ground Station Longitude
GSN	Ground station Serial Number
GSPOS	Ground Station POSition
GSS	Ground Station System
HCR	Highest Closing Rate
I	Information
IATA	International Air Transport Association
ICAO	International Civil Aviation Organisation
ICH	Idle CHannel
INT	Intermediate
INTGS	Intermediate Ground Stations
IRCCH	Initial Response Control Channel
ISDN	Integrated Services Digital Network
kts	knots
LAPDa	Link Access Protocols on the Da channel
LIM	LIMit
LIMALT	LIMit ALTitude
LIMK	LIMit K
LLC	Low Layer Compatibility
LPC	Linear Predictive Coding
LRC	Longitudinal Redundancy Check
LSB	Lowest Significant Bit
M	More
MAXALT	MAXimum ALTitude
MAXRNG	MAXimum RaNGe
MDL	Management Data Link
MM	Mobility Management
MN	Mobile Network
MPH	Management PHysical
MR	Maintenance Resource
MRM	Maintenance Resource Management
MSB	Most Significant Bit
NC	Network Clock
NDC	National Destination Code
NM	Network Management
NMC	Network Management Centre
NOI	Network Operator Identity
OM	Operations and Maintenance
OMC	Operations and Maintenance Centre
OSI	Open Systems Interconnection
PDU	Protocal Data Unit
P/F	Poll/Final

PFD	Power Flux Density
PGS	Power Ground Station
PH	PHysical
PRBS	Pseudo Random Binary Sequence
PRIFRQ	PRImary FReQuency
PSPDN	Packet Switched Public Data Network
PSTN	Public Switched Telephone Network
PWRCTL	PoWeR ConTroL level adjustment
QUINT	Quality INTeRmediate
RACH	Random Access Channel
RC	Retransmission Counter
RCCH	Radio Control Channel
REJ	Reject
RF	Radio Frequency
RLF	Radio Link Failure
RLM	Radio Link Measurements
RMIN	Receiver MINimum acceptable signal level
rms	root mean square
RNR	Receive Not Ready
RPOA	Recognised Private Operators Agency
RR	Radio Resource
RRM	Radio Resource Management
SABM	Set Asynchronous Balanced Mode
SACCH	Slow Associated Control Channel
SAP	Service Access Point
SAPI	Service Access Point Identifier
SDL	System Description Language
SNR	Serial NumbeR
SP	SPare
SSR	Secondary Surveillance Radar
TA	Terminal Adapter
TAC	Type Approval Code
TCH	Traffic Channel
TCLw	weighted Terminal Coupling Loss
TDM	Time Division Multiplex
TDMA	Time Division Multiple Access
TE	Terminal Equipment
TFTS	Terrestrial Flight Telecommunications System
TI	Transaction Identifier
TIM	network TIME
TIMCTL	TIME ConTroL
TMA	Terminal Manoeuvring Area
UA	Unnumbered Acknowledgement
UI	Unnumbered Information
UN	User Number
UT	User Termination
UTC	Universal Time Constant
VCR	Voice Call Record
WARC 92	World Administrative Radio Conference 1992
WOW	Weight on Wheels
WSS	Warm Start Synchronization

## 4 Introduction to TFTS

### 4.1 General

The TFTS supports a wide range of services which a user accesses by a standard set of interfaces and other functional blocks at an AS. The Avionic Termination (AT) of an AS is connected to the TFTS Ground Station System (GSS) as shown in figure 1.



**Figure 1: Basic TFTS interfaces**

The AS-GSS interface is specified in such a way as to permit user and network technologies and configurations to evolve separately.

### 4.2 Interface specification objectives

AS-GSS interface specifications allow:

- different types of AS and terminal equipment to use the same standard interface within the coverage area of the TFTS;
- separate evolution of both aircraft and network equipment technologies and configurations;
- connection of an AS to the fixed network so that the radio channel capacity and protocol restrictions are the only limiting factors;
- satisfactory interworking of TFTS AS equipment supplied by different service providers with the GSSs operated by various network operators.

### 4.3 Interface characteristics

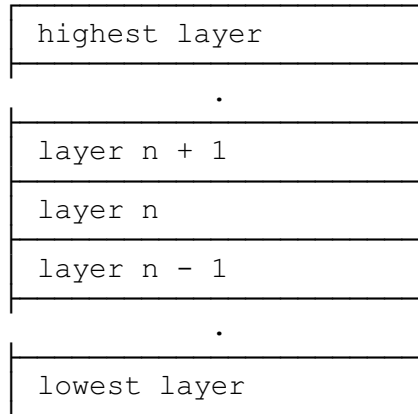
The AS-GSS interface is specified by a comprehensive set of characteristics including:

- channel structures and associated access capabilities;
- user to network (AS-GSS) protocols;
- operation and maintenance characteristics;
- performance characteristics;
- service characteristics.

## 5 Protocol modelling principles

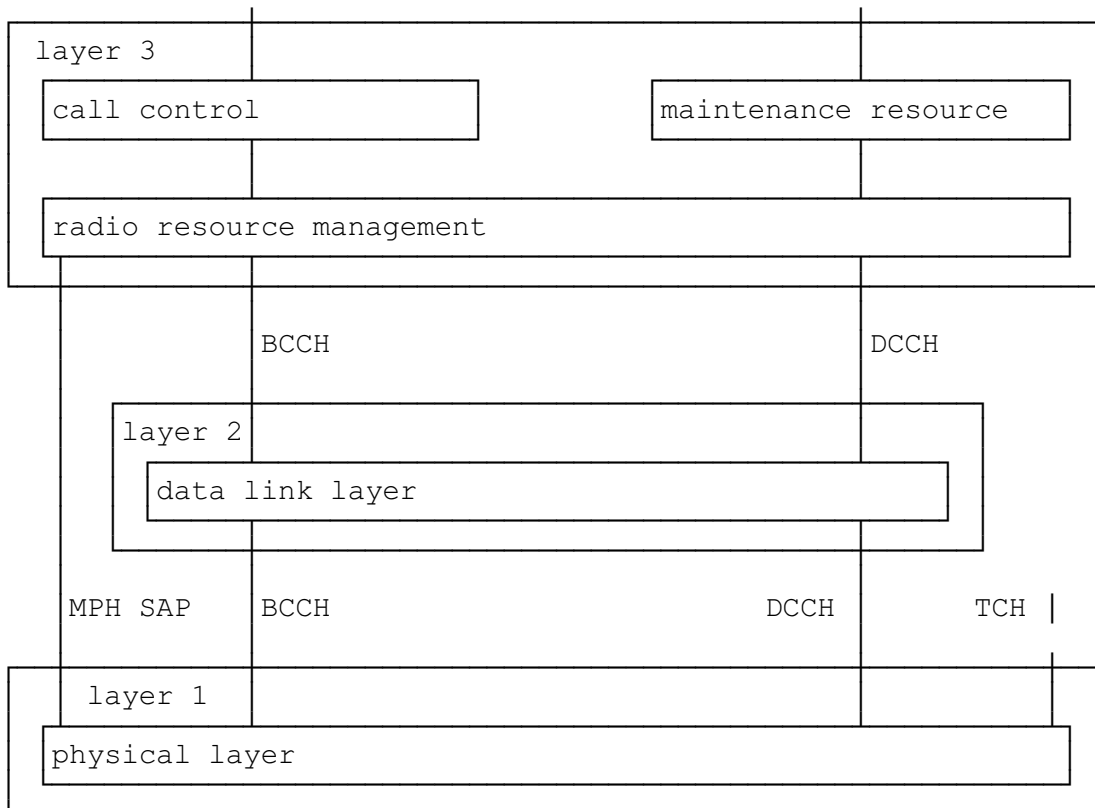
### 5.1 AS-GSS layering

The signalling protocols on the AS-GSS interface are specified using the concepts of the reference model of Open Systems Interconnection (OSI) given in CCITT Recommendations X.200 [3] and X.210 [4] (see figure 2).



**Figure 2: Layering principle**

For signalling on the AS-GSS interface three layers are required. The layers, the main entities and the service access points for communication between layers and peer entities are shown in figure 3.



**Figure 3: ASS - GS Layering**

The functions and protocols of the physical layer are defined in clause 8. The physical layer communicates with the data link layer on the Broadcast Control CHannel (BCCH) and Dedicated Control CHannel (DCCH) Service Access Points (SAP) which correspond to logical channels on the radio path. For support of the Traffic CHannel (TCH) the physical layer also interfaces to other functional units (e.g. speech transcoders).

The data link layer is defined in clause 9.

The network layer is defined in clause 10. The radio resource management entity of the layer 3 also functions as a layer management entity for the two lower layers. Therefore it also has direct control of layer 1 on the Management Physical (MPH)-SAP.

Layer to layer interactions are specified in terms of service primitives. The primitives that are exchanged between layer n+1 and layer n are of the following four types (see figure 4).

**REQUEST primitive:** used when a higher layer is requesting a service from a lower layer.

**INDICATION primitive:** used by a layer providing a service to notify the next higher layer of activities that may be related to the primitive type REQUEST.

**RESPONSE primitive:** used by a layer to acknowledge receipt from a lower layer of the primitive type INDICATION.

**CONFIRM primitive:** used by the layer providing the service to confirm that the activity has been completed.

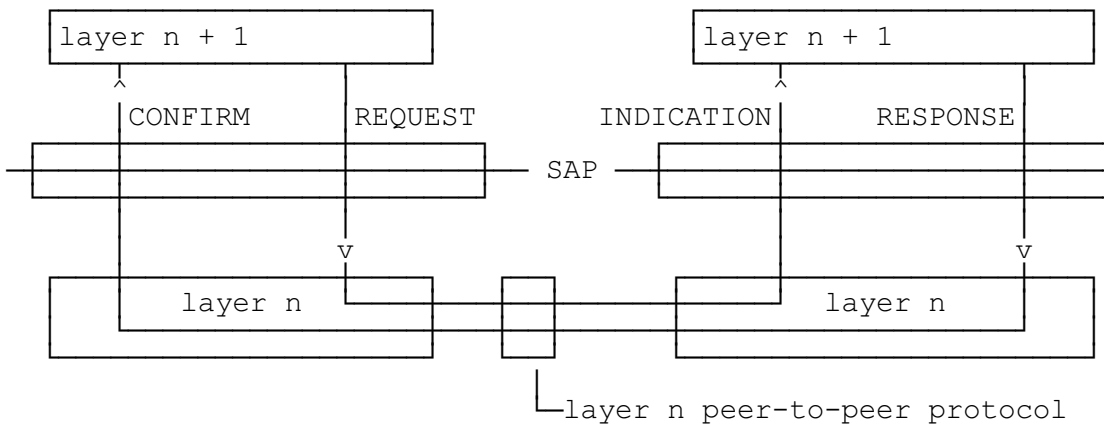


Figure 4: Primitives for protocol modelling

## 6 TFTS user-to-network reference configuration

### 6.1 General

The following subclauses describe the reference configuration for access within the TFTS. A user may access the TFTS by means of interfaces within the aircraft. The interfaces and the functions performed by some of the entities in the aircraft are specified in Aeronautical Radio Incorporated (ARINC) Characteristic 746 [5] and ARINC Characteristic 752 [2] and are reproduced here for information only.

The radio interface is specified in this part of this ETS. This clause defines some possible access configurations in conjunction with the Ground Station (GS) interface and identifies some of the requirements to be performed by the functional groups.

#### 6.1.1 Reference configurations

Reference configurations are conceptual configurations useful for identifying access arrangements to a network. Two concepts are used in defining reference configurations:

- functional groups; and
- reference points.



### 6.1.2 Functional groups

Functional groups are sets of functions which may be needed in network access arrangements. In a particular access arrangement specific functions in a functional group may not be required. Specific functions in a functional group may be performed in one or more pieces of physical equipment.

### 6.1.3 Reference points

Reference points are the conceptual points dividing functional groups. In a specific arrangement reference points may correspond to a physical interface between pieces of equipment. However in general terms a reference point need not necessarily identify a physical boundary or interface.

### 6.1.4 Terminal Equipment (TE)

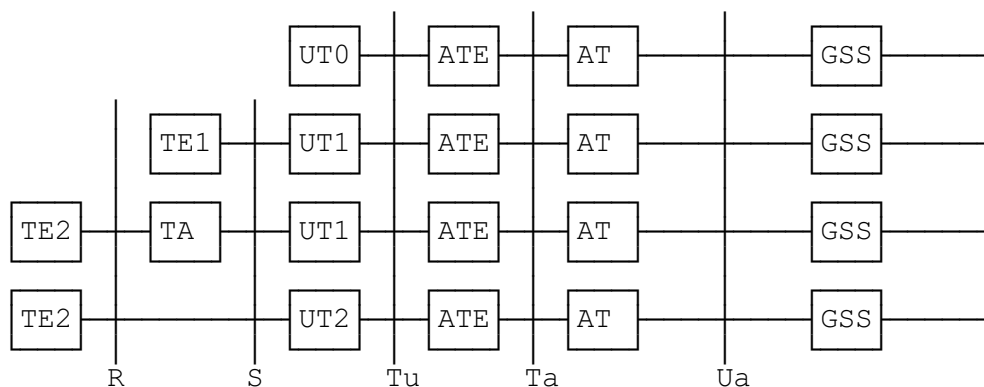
A TE includes functions broadly belonging to layer 1 and higher layers of CCITT Recommendation X.200 [3]. Digital telephones, data equipment and integrated work stations are examples of equipment or combinations of equipment that provide TE facilities. The TE functions are:

- protocol handling;
- maintenance functions;
- interface functions;
- connection functions to other equipment.

The definitions of these functions are described in CCITT Recommendation I.411 [6].

## 6.2 TFTS reference configuration

The reference configuration for TFTS is shown in figure 5.



**Figure 5: TFTS reference configuration**

The TE functional groups are conceptually similar to those in the Integrated Services Digital Network (ISDN) where the S interface complies with the ISDN user/network interface. The R interface complies with an interface recommendation other than the ISDN (e.g. CCITT Recommendations X [7] or V [8] series interface). The new functional groups are:

- 1) Avionic Termination (AT) which performs the following functions:
  - radio transmission and reception;
  - termination of the Aircraft Telecommunication Equipment (ATE);
  - radio transmission channel management;

- speech transcoding (CCITT A-law 64 kbit/s to/from TFTS 9,6 kbit/s using the INMARSAT aeronautical coding algorithm defined in the Inmarsat Aeronautical Satellite Definition Manual [34] and ARINC Characteristic 741 [33]);
- error protection for all information sent across the control channels BCCH, Random Access CHannel (RACH), Initial Response Control CHannel (IRCCH), Radio Control CHannel (RCCH), DCCH and the data traffic channels of the radio path;
- signalling and user data interworking between ATE/AT link format and radio interface format;
- Mobility Management (MM) of AT;
- handover control functions;
- data services layer protocol conversions.

2) ATE which performs the following functions:

- termination of the ATE/AT link;
- call control management (CCM);
- multiple terminal support;
- call queuing;
- Dual Tone Multi-Frequency (DTMF) support;
- data service protocols;
- local credit card validation.

3) User Termination (UT) which performs the following user and network access functions:

- speech encoding/decoding;
- terminal capabilities;
- mapping of protocols where an S or R interface is provided.

Three types of UT are defined:

- UT0 which includes functions belonging to the functional group UT but does not support additional terminal interfaces (e.g. S or R);
- UT1 which includes functions belonging to the functional group UT and includes an interface that complies with the ISDN subset of services offered by the TFTS;
- UT2 which includes functions belonging to the functional group UT and includes an interface that complies with the requirements for TFTS service support for data terminals via a CCITT Recommendations X [7] or V [8] series interface.

The AT, ATE, UT and any other connected terminal equipment form the avionic mobile station.

- 4) Ground Station System which includes the following functions:
- radio transmission and reception;
  - speech transcoding;
  - echo control, tones and announcements information;
  - radio transmission channel management;
  - error protection for information sent over the control and data channels of the radio path;
  - link layer functions for signalling over the radio path;
  - interworking of radio interface signalling to fixed network signalling;
  - service interworking into the fixed network;
  - Call Control management (CCM);
  - RRM;
  - handover management functions.

### **6.3 Interfaces**

In the TFTS reference configuration the reference points Ua and Ta are a TFTS interface point. The Tu reference point between the ATE and the UT is not standardised by ETSI and will be provided by the aircraft operator in line with service requirements. The reference points S and R, where these interfaces are provided by the aircraft operator, will be in accordance with the appropriate interface requirements for terminal equipment (i.e. CCITT Recommendations I.420 [9], I.450 [10] or V [8] or X [7] series).

## **7 Channel structures and access capabilities**

### **7.1 General**

The following clauses defines the sets of channel types, access capabilities and channel configurations supported by the TFTS radio interface at reference point Ua.

Logical channels represent specified portions of the information carrying capacity of an interface. Logical channels are mapped onto physical channels in a time varying way as required. Channels are classified by channel types which have common characteristics. Channel types appearing at the radio interface are specified in subclauses 7.2 and 7.3.

The interface between a GS and the set of ASs with which it is communicating is specified by a combination of channels of particular types. This combination will change with time. The GS access capability is a description of the valid combinations (of which there are a large number). GS access capabilities are defined in subclause 7.4. Similarly at a given point in time the interface between an AS and the GS with which it is communicating is specified by a combination of channels of particular types; these channel combinations will change with time.

### **7.2 Channel types and their use: Traffic Channels**

TCHs are fixed gross rate channels. A TCH shall not carry signalling information for circuit switching, AS management or CCM functions. The TCH shall be used as a channel for user information, primarily speech. A subsequent TFTS ETS will define further user capabilities for data and fax on the TCH.

- 1) Ba channel: a Ba channel shall carry either:
  - a 9,6 kbit/s bit stream with an error structure and transmission delay suitable to carry voice encoded information as described in clause 8; or
  - a bit stream at a gross rate of 9,6 kbit/s with an error structure and transmission delay adapted to a wider range of services.
- 2) Ma channels: an Ma channel shall be a traffic channel with a gross data rate of 4,8 kbit/s. The use of Ma channels is outside the scope of this ETS.
- 3) La channels: an La channel shall be traffic channel with a gross data rate of 2,4 kbit/s. The use of La channels is outside the scope of this ETS.

### **7.3 Channel types and their use: Control channels**

Control channels shall be used to provide all active ASs with a continuous frame oriented means of communicating with a GS over the radio link. Control channels are specified by their type as described in the following subclauses. Control channels are defined as Da channels.

#### **7.3.1 Logical control channel types**

##### **7.3.1.1 Broadcast Control CHannel (BCCH)**

A BCCH is a point-to-multipoint unidirectional control channel from the GS to AS. A BCCH broadcasts a variety of information to ASs to allow them to make decisions regarding network access, link set-up, and other similar functions. The BCCH is divided into two parts, BCCH(S) and BCCH(D), as specified in subclauses 8.6.3 and 8.10.10.

##### **7.3.1.2 Random Access CHannel (RACH)**

A RACH is a multipoint-to-point unidirectional channel from an AS to the GS. It allows an AS to request an initial physical connection to a GS.

##### **7.3.1.3 Initial Response Control CHannel (IRCCH)**

An IRCCH is a point-to-point unidirectional channel from the GS to the AS. It allows a GS to grant an initial physical connection to an AS and indicate the timing adjustment for the AS transmission.

##### **7.3.1.4 Radio Control CHannel (RCCH)**

A RCCH is a point-to-point GS to AS unidirectional control channel. It carries power and timing controls from the GS to the AS. As this control channel is unidirectional a re-transmission protocol cannot be used.

##### **7.3.1.5 Dedicated Control CHannel (DCCH)**

A DCCH is a point-to-point bidirectional control channel. It carries CCM messages relating to all calls originating from an AS and Operational and Maintenance (OM) messages. This channel may be used to carry other types of data in a future TETS ETS. The data rate of the DCCH is dependent on the number of traffic slots allocated to the AS and whether any traffic channels are in use.

A DCCH shares physical channel capacity with any TCHs allocated to an AS. When a TCH is not connected, all the TCH's physical channel capacity will be available for the DCCH. When a TCH is connected, only limited capacity is available to the DCCH. These conditions are referred to as a Fast Associated Control CHannel (FACCH) and Slow Associated Control CHannel (SACCH) respectively.

#### 7.4 GS Access capability

The following symbols apply to the access capability relationships:

b = number of Ba channels;  
m = number of Ma channels;  
l = number of La channels;  
d = number of DCCH;  
p = number of RCCH;  
r = number of RACH;  
i = number of IRCCH;  
bc = number of BCCH.

The GS access capability shall be constrained as follows for each radio channel available at the GS:

1)  $4b + 2m + bc + l \leq 16$ ;

2)  $d \leq 16 - m - 3b$ ;

NOTE 1: These relationships follow from the number of physical channels required to support a particular type of logical channel. Refer to subclause 8.6.3 for the frame characteristics.

3)  $p = d$ ;

NOTE 2: There will always be a RCCH to control power and timing for each DCCH.

4)  $r \leq 1$  when  $4b + 2m + l < 16$ ;

NOTE 3: A RACH is only available on access carriers if there is capacity available in the GS but present only on frames corresponding to BCCH(S) (see subclause 8.6.3).

5)  $i = r$ ;

NOTE 4: The RACH and IRCCH are always paired

6)  $bc = 1$ .

NOTE 5: There is a BCCH(D) available only on the access carrier when capacity is available at the GS. See subclause 8.6.3

NOTE 6: The above are constraints on the access capability. A particular GS might not support all possible valid combinations (eg mixtures of Ba and Ma channels) due to implementation limitations.

The following are examples of valid access combinations:

1) one TCH for each of three ASs:

1	BCCH(S)	(Tx only);
1	BCCH(D)	(Tx only if capacity available);
1	RACH	(Rx only if capacity available);
1	IRCCH	(Tx only);
3	DCCH;	
3	RCCH	(Tx only);
3	TCH	(one per DCCH);

2) four Ba channels allocated to one AS:

1	BCCH(S)	(Tx only);
0	BCCH(D);	
1	DCCH;	
4	TCH	(Ba);
1	RCCH	(Tx only).

### 7.5 AS access capability

The AS access capability shall be constrained as follows for each radio channel available at the AS (see subclause 7.4 above for symbol definitions):

1)  $4b + 2m + bc + l \leq 16$ ;

2)  $d \leq 1$ ;

NOTE 1: These relationships follow from the number of physical channels required to support a particular type of logical channel. An AS may only have one DCCH.

3)  $p = d$ ;

NOTE 2: There will always be an RCCH to control power and timing for the DCCH.

4)  $r \leq 1$ ;

NOTE 3: The GS controls the availability of RACH channels depending on available TCH capacity.

5)  $i = r$ ;

NOTE 4: The RACH and IRCCH are always paired.

6)  $bc \leq 1$ .

NOTE 5: There is a BCCH(D) available only when there is capacity at the GS.

Examples of valid combinations are:

1) one TCH only allocated:

1	BCCH(D)	(Rx only if access carrier);
1	BCCH(S)	(Rx only);
1	RACH	(Tx only);
1	IRCCH	(Rx only);
1	DCCH;	
1	RCCH	(Rx only);
1	TCH;	

2) four Ba channels allocated to one AS:

1	BCCH(S)	(Rx only);
0	BCCH(D);	
1	DCCH;	
4	TCH	(Ba);
1	RCCH	(Rx only).

## 8 TFTS Radio Interface Layer 1

This clause defines and specifies the services offered by the physical layer of the TFTS AS - GSS interface.

### 8.1 Interfaces to the physical layer

The physical layer (layer 1) is the lowest layer of the OSI reference model and it shall support all functions required for the transmission of bit streams on the physical medium. These bit streams shall be transferred on logical traffic and control channels as defined in clause 7. The physical layer shall interface the data link layer and support the functional units of the application (see figure 6). Interfaces between the layer 1 and higher layers shall be described by the exchange of primitives. These descriptions shall not imply nor constrain any implementations.

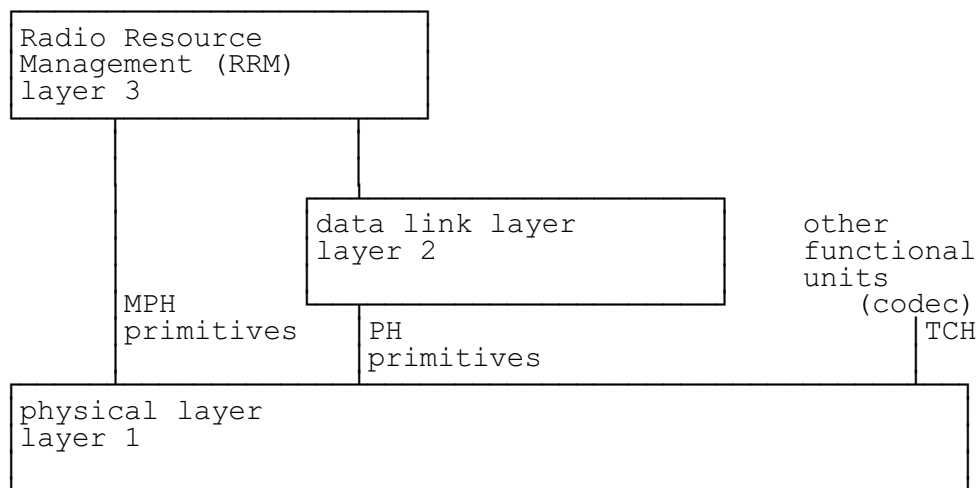


Figure 6: Interfaces to the physical layer

#### 8.1.1 Interface to layer 2

The physical layer shall interface with layer 2 to support control channels. Layer 2 is defined in clause 9. Communication between layer 1 and layer 2 shall be by PPhysical (PH) primitives. The PH primitives exchanged between layer 1 and layer 2 shall be used for the transfer of layer 2 frames.

#### 8.1.2 Interface to radio resource management

Layer 1 shall interface to the Radio Resource Management (RRM) entity of layer 3 in the AS and in the GSS. Communication between layer 1 and layer 3 shall be performed by MPH primitives.

NOTE: The primitives exchanged with the RRM are related to the assignment of channels and physical layer system information.

#### 8.1.3 Interface to other functional units

Layer 1 shall interface to other functional units in the AS and GSS and support traffic channels (e.g. encoded speech information).

### 8.2 Services of Layer 1

Layer 1 shall provide the radio transmission service.

### 8.2.1 Service Access Point (SAP)

In the OSI model SAPs are defined as gates through which services are offered to an adjacent higher layer as shown in figure 7. Layer 1 shall offer a service to layer 2 through a SAP which shall be used both for the control of the service providing entity and the transfer of data.



Figure 7: Service Access Point

NOTE: Layer 1 SAPs for TFTS differ from the OSI layer 1 SAPs since the layer 3 RRM directly controls the SAPs (for establishment and release of channels) instead of layer 2.

For layer 1 of the TFTS a SAP is defined between the physical and data link layers for each control channel as shown in figure 8. The characteristics of SAPs are listed in clause 5.

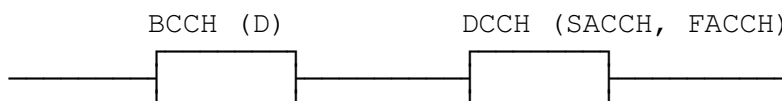


Figure 8: SAPs between layer 1 and layer 2

### 8.2.2 Service provided

Layer 1 shall offer a transmission service on a limited set of logical channels. The GS and AS access capabilities to these channels are specified in clause 7. Logical channels shall be multiplexed onto physical channels. Physical channels are the units scheduled on the radio medium. Some logical channels shall be reserved by the TFTS for common use. Others shall be assigned to specific ASs. Data on SAPs of control channels shall be exchanged in discrete blocks.

For logical channels requiring a low error rate (e.g. network signalling) layer 1 shall provide a protected transmission with an error correction service (see subclause 8.6). Layer 1 shall not implement any error detection for the layer 2 frames. This function shall be performed by layer 2.

#### 8.2.2.1 Specific services of layer 1 in the AS

The access capability service of layer 1 in the AS for dedicated physical channels is different from that of the BCCH. Establishment of physical channels on the physical layer shall be controlled by the RRM entity of layer 3.

During operation on a dedicated physical channel the physical layer shall measure the signal of neighbouring ground stations by monitoring their BCCH's and the quality of the physical channel being used for communication. The resulting information shall be passed to the RRM entity of layer 3. Layer 3 shall provide measurement control information.

In idle mode layer 1 shall pass the results of this measurement to the layer 3 RRM for analysis. If layer 3 CCM requests a physical channel the RRM shall base the decision for cell selection on the information received from layer 1 in accordance with the procedure specified in subclause 8.10.



### 8.3 Primitives of layer 1

Layer 1 interacts with other entities as shown in figure 6 above. The interactions with layer 2 Da channels are shown in terms of primitives where the primitives represent the logical exchange of information between the layer 1 and its adjacent layer.

#### 8.3.1 Generic names of primitives between layer 1 and layer 2 for the transfer of layer 2 frames

The following primitive generic names are defined on the SAPs between layer 1 and layer 2:

- 1) PH - DATA;

NOTE 1: The PH - DATA primitives are used on a SAP to pass message units containing frames used for data link layer peer to peer communications and from the physical layer.

- 2) PH - G2;

NOTE 2: The PH - G2 primitive is used on the DCCH SAP to control the timing of layer 2 according to the capacity of the DCCH.

#### 8.3.2 Generic names of primitives between layer 1 and the radio resource management entity of layer 3

The following primitive generic names are defined between layer 1 and RRM of layer 3.

- 1) MPH - INFORMATION (MPH - INFO);

NOTE 1: The MPH - INFORMATION primitives are used to control measurement activities of layer 1 by the RRM entity of layer 3. They transfer measurement results from layer 1 and measurement control information to layer 1.

- 2) MPH - CONFIGURE (MPH - CNFG);

NOTE 2: The MPH - CONFIGURE primitives are used for control of the physical layer by the RRM of layer 3.

These primitives activate and de-activate, configure and de-configure, and connect and disconnect physical and logical channels.

- 3) MPH - RANDOM - ACCESS (MPH - RA);

NOTE 3: The MPH - RANDOM - ACCESS primitives are used to control the cold start access of an AS to a radio channel. At the AS they request initiation and confirmation of completion of the random access transaction. At the GS they indicate the request of an AS for the negotiation slot. The random access transaction is described in subclause 8.5.3.

- 4) MPH - CHANNEL ACCESS (MPH - CA);

NOTE 4: The MPH - CA primitive is used to control a procedure to allow the acquisition of the AS by the GS and to synchronise the transmissions of the AS and GS. At the AS they request initiation and confirm completion of the channel access transaction. At the GS they indicate the reception of an entry slot and synchronisation of an AS to a GS. The channel access transaction is described in subclause 8.5.4.

#### 8.3.3 Primitive types

The primitive types are defined in subclause 8.1.

8.3.4 Parameter definition

Primitives contain a variable number of parameters as listed in table 1.

Table 1: Primitives of the physical layer

PRIMITIVES OF THE PHYSICAL LAYER AND THE PARAMETERS			MESSAGE UNIT				
			CHANNEL CONTROL PARAM		SYSTEM INFO		MEASUREMENT
	ENTITY	DIRECTION					
MPH - CNFG - REQ	AS/GS	RR(L3) ->L1	X				
MPH - CNFG - CON	AS/GS	L1->RR(L3)	X				
MPH - CNFG - IND	AS/GS	L1->RR(L3)	X				
MPH - INFO - REQ	AS/GS	RR(L3) ->L1		X			
MPH - INFO - CON	AS/GS	L1->RR(L3)		X			
MPH - INFO - IND	AS/GS	L1->RR(L3)		X	X		
MPH - RA - REQ	AS	RR(L3) ->L1	X				
MPH - RA - CON	AS	L1->RR(L3)	X				X
MPH - RA - IND	GS	L1->RR(L3)					
MPH - CA - REQ	AS	RR(L3) ->L1	X				
MPH - CA - CON	AS	L1->RR(L3)	X				X
MPH - CA - IND	GS	L1->RR(L3)					
PH - DATA - REQ	AS/GS	L2->L1	X				
PH - DATA - IND	AS/GS	L1->L2	X				
PH - G2 - IND	AS/GS	L1->L2					

Parameters involved in the primitive exchange with layer 1 are:

- message unit which contains peer to peer information of a layer. It is transferred to layer 1 by the peer layer;
- channel control parameters which contain information for channel control;
- system information which is exchanged in the GS monitoring procedures;
- measurements which is used to report the measurement data of a dedicated physical channel and of surrounding BCCH carriers (AS only);
- Error code which used by the MPH - RA - CON and MPH - CA - CON primitives to indicate success or failure of the corresponding transactions.

## 8.4 Layer 1 procedures

### 8.4.1 States of layer 1

In layer 1 of the AS the following states are defined:

NULL	the equipment is switched off;
IDLE	under the control of layer 3, layer 1 scans the radio resource for usable BCCH. It passes the BCCH(D) data to layer 2;
TUNING DCH	layer 1 receives a request for a physical connection. It tries to establish a connection;
DCH	layer 1 has established a physical connection and may through connect logical channels.

In all states, except the null state, layer 1 shall continue to scan the radio resource to update and extend the table of GS data kept by the RRM function of layer 3. Figure 9 gives a general state diagram of layer 1. All state transitions of layer 1 shall be controlled by MPH primitives.

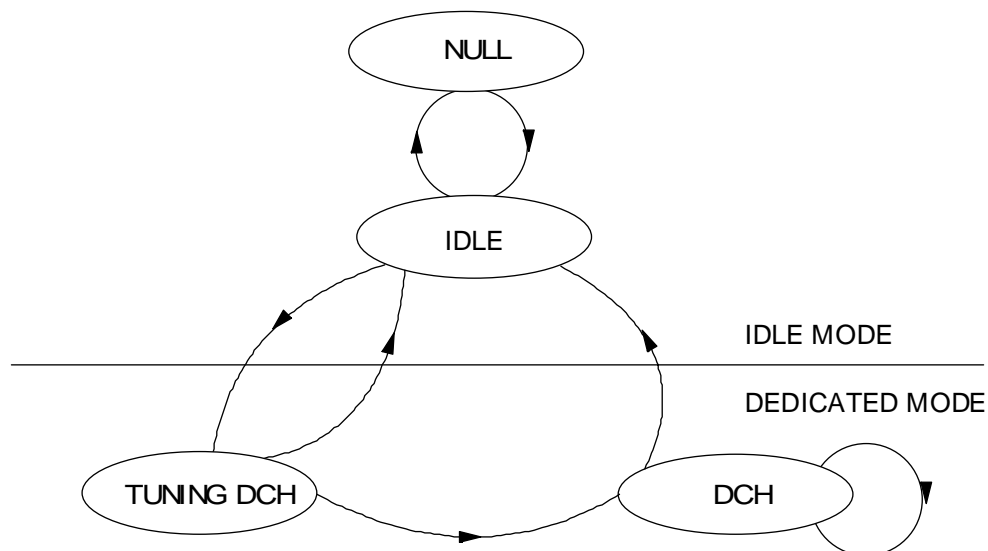


Figure 9: States of the physical layer in the AS

### 8.4.2 Remap procedure

As the RRM in the GS and the RRM in the AS are not able to command configuration of their layer 1 at the same time, the number of slots allocated to the DCCH may be inconsistent between them. This may cause the loss of layer 2 messages and disconnection of the data link.

A procedure call the "remap procedure" is defined for synchronising the addition and reduction of timeslots between the AS and GS.

Layer 3 shall request layer 1 to perform a remap by sending a MPH-CNFG-REQ (remap) primitive. When the process is complete layer 1 shall inform layer 3 by sending a MPH-CNFG-IND primitive.

The MPH-CNFG-REQ primitive shall contain the list of timeslots to remap and the initial and final state of each timeslot.

During the remap procedure the state of a timeslot shall move from an initial state to a final state: from free to G1/G2 or from G1/G2 to free. The initial states of the timeslots to remap may be different.

#### 8.4.2.1 Channel remap protocol

Because the GS allocates radio resources the GS layer 1 is the first entity to be aware of a change. The GS RRM shall request a remap of its layer 1. When receiving the MPH-CNFG-REQ primitive the GS layer 1 shall wait for the timeslots involved in the remap to be received with their new states. The state of the transmitted slots shall remain unchanged.

On receiving the RRM message from the GS the AS RRM shall request layer 1 to remap. When receiving the MPH-CNFG-REQ primitive the AS layer 1 shall change the state of the transmitted slot to the final state.

When the GS layer 1 detects reception of four consecutive timeslots in the new state it shall switch the transmission to the final state and inform layer 3.

When the AS layer 1 receives the final slot state in four consecutive timeslots it shall inform layer 3. The remap procedure is then completed.

NOTE: The switch from G1 to G2 or G2 to G1 is processed asynchronously between the AS and GS as there is no change in the number of allocated timeslots.

#### 8.4.3 Layer 1 interface procedures

One type of primitive is defined for the communication between layer 1 and layer 2 both in the AS and GS.

For an established full duplex control channel DCCH on both AS and GS, or on the simplex channel BCCH(D) in the AS, the data blocks received and eventually error corrected by layer 1 shall be contained in the PH - DATA - INDICATION primitives on the corresponding SAP. On a full duplex control channel, or on the simplex channel BCCH in the GS, the layer 2 shall provide to layer 1 data blocks to be transmitted by the radio sub-system in the PH - DATA - REQUEST primitives.

For an established full duplex control channel DCCH on both the AS and GS the reception of a G2 slot for the DCCH shall be indicated to layer 2 by a PH - G2 - INDICATION primitive. The primitive shall always be generated if a G2 slot is expected according to the current channel configuration. It shall only be suppressed on the AS if a G3 slot for the RCCH is received.

NOTE: Refer to subclause 8.6.2 for definition of G2 and G3.

In the AS idle mode the initiation of random access transactions (cold start request for a negotiation slot) shall be requested by the MPH - RA - REQUEST primitive. Layer 1 of the AS shall confirm completion of the transaction to RRM indicating success or failure in a MPH - RA - CONFIRM primitive. Layer 1 of the GS shall provide correctly received random access attempts to the GS RRM in a MPH - RA - INDICATION primitive.

In the AS the initiation of a channel access transaction shall be requested by the MPH - CA - REQUEST primitive. Layer 1 of the AS shall confirm completion of the transaction to RRM indicating success or failure in a MPH - CA - CONFIRM primitive. Layer 1 of the GS shall indicate correctly received entry slots from a channel access transaction in a MPH - CA - INDICATION primitive. The synchronisation procedure is called cold start synchronisation during call initiation and warm start synchronisation during handover (see subclause 8.11).

## 8.5 Layer 1 peer to peer exchanges

### 8.5.1 BCCH Synchronisation (S) transmission

Layer 1 of the GS shall transmit the BCCH(S) on each carrier. The BCCH(S) shall be used by the AS to synchronise to the transmissions on the carrier. Data included with the BCCH(S) shall indicate to the AS where to initiate an access procedure (access channel and negotiation timeslot).

For the BCCH(S), layer 1 shall transmit an S1 slot in slot 16 of certain frames. The exact mapping of the BCCH(S) to slots on the carrier, as well as the data content and the coding of the data fields of the S1 slot, is described in subclause 8.6.

On initial access the down-link counter-part of the BCCH(S) shall be used by the AS for transmission of the entry slot in random access transactions.

### 8.5.2 Layer 1 radio control

Layer 1 shall provide a peer to peer protocol to control the timing and power levels of the radio channel. This is achieved at call initiation by means of an IRCCH for timing control and during established communications by means of an RCCH. IRCCH and RCCH are supported by G3 slots.

The RCCH on the GS shall periodically transmit a G3 slot in place of the slots allocated to the DCCH in slot 16. This shall indicate the time delay and the required power level to the AS. Layer 1 in the AS shall adjust timing of slot transmissions and the power level according to the values provided by the RCCH.

The timing requirement for the periodic transmission of the G3 slot is defined in subclause 8.10.10. The slot type G3 format and coding for the G3 data blocks are defined in subclause 8.6. The data content is described in table 2.

**Table 2: Data contents of G3 slot**

Data field	Used by
timing offset	RCCH and IRCCH (random access and channel access)
power control	RCCH
entry id	IRCCH (random access)

### 8.5.3 Layer 1 random access procedures

Layer 1 shall implement a transaction for the AS to request access to the negotiation slot on the access carrier of a GS.

The following procedure shall be provided at the AS:

- 1) on reception of a MPH-RA-REQUEST primitive layer 1 shall send a RACH supported by a S2 slot on the down-link counter-part of the BCCH(S) channel of the access carrier using a randomly determined entry identity. It shall then monitor the negotiation slot of the following up-link frame for the reception of a IRCCH (G3 slot) with matching entry identity (see subclause 8.10.4);
- 2) if a match is found, a MPH-RA-CONFIRM primitive shall be issued to RRM indicating the success of the random access procedure and containing the power level of AS transmissions as defined in subclause 8.10.4. Layer 1 shall configure for transmission of the DCCH on the negotiation slot using the timing offset indicated by the G3 slot;
- 3) if a match is not found, the procedure in a) shall be repeated for a further three attempts with an interval between attempts and with transmission levels as described in subclause 8.10. If no attempt

succeeds a MPH-RA-CONFIRM primitive shall be issued to RRM indicating failure of the random access procedure.

The following procedure shall be provided at the GS:

- 1) layer 1 of the GS shall continually scan the down-link counter-part of the BCCH(S) channel for reception of a RCCH (S2 slot). If an S2 slot is received, layer 1 shall respond in the negotiation slot of the following GS frame with a IRCCH (G3 slot), echoing the entry identity and providing power and time correction information derived from the GS by reception of a RCCH;
- 2) the random access shall then be indicated to the GS RRM by a MPH-RA-INDICATION primitive and layer 1 shall configure for reception of a DCCH on the negotiation slot. The negotiation slot shall then be allocated to the calling AS. RRM shall indicate a new negotiation slot number and a new access carrier (determined according to the rules for traffic balancing described in ETS 300 326-3 [11] clause 6) to layer 1 to be transmitted in the next BCCH(S) slot.

#### **8.5.4 Layer 1 channel access transaction**

Layer 1 shall implement a transaction to synchronise the GS to transmissions from the AS during handover.

The following procedure shall be used at the AS:

- 1) after reception of a MPH-CA-REQUEST primitive layer 1 shall send an entry S2 slot on the first slot allocated to the AS ie the lowest numbered slot allocated (see subclause 10.11.3.4.2). Layer 1 shall then monitor the first allocated slot in the up-link direction for reception of a G3 slot;
- 2) if a G3 slot is found a MPH-CA-CONFIRM primitive shall be issued to RRM indicating the success of the channel access transaction and the power level of the AS transmissions as defined in subclause 8.10.5. Layer 1 shall adjust its transmissions using the timing offset received with the G3 slot (see table 2);
- 3) if a G3 slot is not found the procedure in a) shall be repeated for a further three attempts with an interval between attempts and with power levels as described in subclause 8.10.4. If no attempt succeeds a MPH-CA-CONFIRM primitive shall be issued to RRM indicating failure of the channel access procedure.

The following procedure shall be used at the new GS:

- layer 1 shall continually scan the first allocated slot in the down-link direction for reception of a S2 slot. If this is received, layer 1 shall respond on the first allocated slot in the up-link direction with a G3 slot indicating the time delay of the S2 slot. The channel access shall then be indicated to RRM by a MPH-CA-INDICATION primitive.

### **8.6 TDMA characteristics**

#### **8.6.1 General**

This subclause defines the physical resources provided by Layer 1 (the physical layer) for the TDM and TDMA frame, super-frame and slot structures.

TFTS shall use three types of slot format in normal operation and two types of slot format for synchronisation.

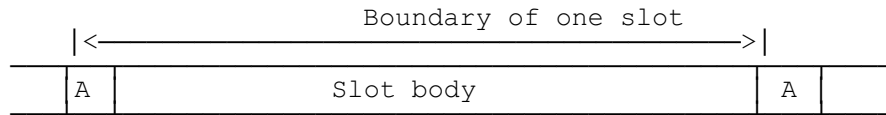
The TFTS transmission structure shall use a Time Division Multiplexing (TDM) transmission for ground to air transmissions and Time Division Multiplexing Access (TDMA) in the reverse direction. The TDM signal shall be organised into a frame of time segments or slots. Frames shall be organised into a super frame. The TDMA down-link shall be organised in the same manner as the up-link. The up-link and down-link shall be synchronised so that the down-link appears a fixed number of slots later than the up-link when viewed at the GS (refer to subclause 8.6.4). Each time-slot of approximately 4,706 ms shall comprise 208 bits. 17

time-slots shall be combined into a frame of 80 ms. Twenty frames shall be combined into a super-frame of 1,6 seconds.

**8.6.2 Slot structure**

The three types of slot for general use are known as G1, G2 and G3 and the two types of slot for synchronisation are known as S1 and S2;

Figure 10 shows the basic slot structure.

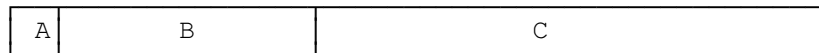


**Figure 10: Slot structure**

The field A is a guard time for all slots to allow the AS transmitter power to be ramped up and down in a controlled way and to reduce adjacent channel interference. The power ramping function is defined in subclause 8.8.2.3. The power shall not be ramped between adjacent slots transmitted by the same AS. Field A of all slot types shall carry all zeros. The GS shall not ramp its power level between slots.

**8.6.2.1 General slot types**

Figure 11 shows the general slot structure and table 3 shows the allocation of bits within slots with bit 0 transmitted first.



**Figure 11: Structure of general slots**

**Table 3.a: Bit allocations of general slots**

Slot Type	Bit allocation		
	A	B	C
G1	0 - 4 Guard	5 - 15 Synch	16 - 207 Traffic data
G2	0 - 4 Guard	5 - 15 Synch	16 - 207 control data
G3	0 - 4 Guard	5 - 15 Synch	16 - 207 Specific data

**Table 3.b: Coding of field B**

Bit position	5	6	7	8	9	10	11	12	13	14	15
Slot type G1	1	0	0	0	0	0	1	0	1	0	0
Slot type G2	0	0	1	0	0	0	1	0	0	0	1
Slot type G3	0	0	0	0	1	0	0	0	1	0	1

NOTE: All spare bits are coded binary 0.

8.6.2.1.1 Field data

Field C of slot type G1 shall carry TCH data. Field C of slot type G2 shall carry layer 2 frames for BCCH(D) or DCCH. The layer 2 frames shall be coded as specified in subclause 8.6.5.2. Field C of slot type G3 shall carry IRCCH or RCCH specific control data.

The information in slot type G3 is coded as shown in table 4 and specified in subclause 8.6.5.3.

**Table 4: Field C information of G3 slot**

Function	Length (bits)	Description
Timing offset	11	11 bit offset (see note 1)
Power control	5	Transmit power relative to max Equivalent Isotropic Radiated Power (EIRP) (see note 2)
Entry identity	12	aircraft entry ID for initial access (see note 3)
Spare	4	for future use (note 4)

NOTE 1: Offset in  $T_b/4$  increments (where  $T_b$  represents a bit period). Positive values represent advancing timing and negative values retarding timing. The values are expressed in twos complement giving an adjustment range of + 1023 to - 1024  $T_b/4$ . The timing adjustment represents the correction required. That means:

- advance of the GS receive timing error if the signal arrives too late at the GS;
- retard of the GS receive timing error if the signal arrives too early at the GS.

NOTE 2: The 5 bits define in natural binary code the transmit power relative to the maximum level of the AS. The adjustment is in - 5 dB steps where 00000 indicates 0 dB relative and 00001 indicates - 5 dB relative. 10 000 indicates minimum EIRP of - 80 dB relative.

NOTE 3: The 12 bit random word is used to identify the aircraft during initial synchronisation. The entry ID is only valid when used to transport IRCCH and is set to zero (default) for RCCH.

NOTE 4: This field may be used in future for a network identity parameter. If the field is not used all spare bits are coded as binary 0.

Figure 12 shows the bit position for each field in a four octet data field.

0	10	11	15	16	27	28	31
lsb	msb	lsb	msb	lsb	msb	lsb	msb
Timing		power control		entry ID		spare	

**Figure 12: Specific control data field for slot type G3**



**8.6.2.2 Synchronisation slot types**

Figure 13 shows the synchronisation slot structure and table 2 shows the allocation of bits within the slot.



**Figure 13: Structure of Synchronisation slots**

**8.6.2.2.1 Field data**

For slot types S1 and S2 fields C and D shall be used to carry BCCH(S) containing identification of the frame number, BCCH (D) slot number and negotiation slot number as shown in tables 4.a, 4.b and 4.c. For slot type S2 field C shall be used to carry RACH containing the entry identity of the AS with the same format as defined in subclause 8.6.2.1.1 for the G3 slot.

**Table 4.a: Allocation of Synchronisation slots**

	A	B	C	D
S1	0 - 4 Guard	5 - 75 synchronisation word	76 - 207 Data	
S2	0 - 4 Guard	5 - 75 synchronisation word	76 - 87 Data	

NOTE: Slot type S2 only contains 88 bits.

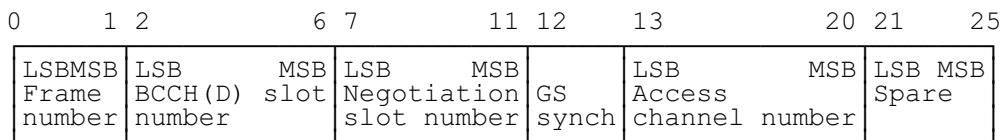
**Table 4.b: Synchronisation word coding of field B for slot types S1 and S2**

Bit position	5	24
+0	11001011001100011000	
+20	00000100111001110011	
+40	00011010101011001110	
+60	01100001100	

**Table 4.c: Bit allocations**

Field Content	Field Length	Description
Frame number	2	Frame number within super-frame where 00 = frame 0 01 = frame 5 10 = frame 10 11 = frame 15
BCCH (D) slot number	5	Slot number indicating position 0 - 15 of BCCH(D) Slot number 31 indicated that no BCCH(D) is transmitted on that carrier
Negotiation slot number	5	Slot number to be used for initial negotiation (0 - 15). A negotiation slot number of 31 indicates that a negotiation slot is not available
Access channel	8	Indicates the access channel number coded as defined in subclause 8.8.1.1.2 for the RF channel number
GS synch	1	GS synchronisation status 0 - GS unsynchronised 1 - GS synchronised
Spare	5	Spare / network identity

Figure 14 shows the bit position for each field content in the data field. The data field shall be channel coded as specified in subclause 8.6.5.4.



**Figure 14: Type S1 data field**

If the S1 data field cannot be decoded correctly as specified in subclause 8.6.5.5 the AS shall not transmit a S2 slot until another S1 slot has been received.

The data field C for slot S2 shall contain twelve bits of entry ID data. Field D shall be an additional guard time inserted to allow transmission when the AS has not acquired network time.

**8.6.3 Functions of logical channels and mapping to physical channels**

The frames and super-frames are organised as shown in tables 5 and 6 using a Ba channel as defined in clause 7. Table 5 shows a typical example of a partially full Ba channel on the access carrier and table 6 a full capacity Ba channel.

Table 7 shows the implementation for an Ma channel. The organisation for an La channel is shown in table 8. Slots are transmitted in ascending order of slots and then ascending order of frames. C represents a control channel (DCCH). B(S) represents a synchronisation slot of the BCCH(S). B(D) represents the data for the broadcast control channel BCCH(D). T represents a traffic channel TCH. A TCH may be replaced by a DCCH or BCCH(D) if necessary.

The slots for a Ba channel shall be allocated such that they conform to n, n + 4, n + 8, n + 12 where 0 <= n <= 3.

The slots for a Ma channel shall be allocated such that they conform to  $n, n + 8$  where  $0 \leq n \leq 7$ .

The slots for La channel shall be allocated such that they conform to  $n$  where  $0 \leq n \leq 15$ .

**Table 5: Frame and super-frame organisation for a typical Ba channel with free capacity**

Frame	Slot number																
	0	1	2	3	4	5	6	7	8	9	10	11	12	13	14	15	16
0	T1	T2	T3	B(D)	T1	T2	T3	-	T1	T2	T3	-	T1	T2	T3	-	B(S)
1	T1	T2	T3	B(D)	T1	T2	T3	-	T1	T2	T3	-	T1	T2	T3	-	C1
2	T1	T2	T3	B(D)	T1	T2	T3	-	T1	T2	T3	-	T1	T2	T3	-	C2
3	T1	T2	T3	B(D)	T1	T2	T3	-	T1	T2	T3	-	T1	T2	T3	-	C3
4	T1	T2	T3	B(D)	T1	T2	T3	-	T1	T2	T3	-	T1	T2	T3	-	-
5	T1	T2	T3	B(D)	T1	T2	T3	-	T1	T2	T3	-	T1	T2	T3	-	B(S)
6	T1	T2	T3	B(D)	T1	T2	T3	-	T1	T2	T3	-	T1	T2	T3	-	C1
7	T1	T2	T3	B(D)	T1	T2	T3	-	T1	T2	T3	-	T1	T2	T3	-	C2
8	T1	T2	T3	B(D)	T1	T2	T3	-	T1	T2	T3	-	T1	T2	T3	-	C3
9	T1	T2	T3	B(D)	T1	T2	T3	-	T1	T2	T3	-	T1	T2	T3	-	-
10	T1	T2	T3	B(D)	T1	T2	T3	-	T1	T2	T3	-	T1	T2	T3	-	B(S)
11	T1	T2	T3	B(D)	T1	T2	T3	-	T1	T2	T3	-	T1	T2	T3	-	C1
12	T1	T2	T3	B(D)	T1	T2	T3	-	T1	T2	T3	-	T1	T2	T3	-	C2
13	T1	T2	T3	B(D)	T1	T2	T3	-	T1	T2	T3	-	T1	T2	T3	-	C3
14	T1	T2	T3	B(D)	T1	T2	T3	-	T1	T2	T3	-	T1	T2	T3	-	-
15	T1	T2	T3	B(D)	T1	T2	T3	-	T1	T2	T3	-	T1	T2	T3	-	B(S)
16	T1	T2	T3	B(D)	T1	T2	T3	-	T1	T2	T3	-	T1	T2	T3	-	C1
17	T1	T2	T3	B(D)	T1	T2	T3	-	T1	T2	T3	-	T1	T2	T3	-	C2
18	T1	T2	T3	B(D)	T1	T2	T3	-	T1	T2	T3	-	T1	T2	T3	-	C3
19	T1	T2	T3	B(D)	T1	T2	T3	-	T1	T2	T3	-	T1	T2	T3	-	-

Table 6: Frame and super-frame organisation for a Ba channel with no free capacity

Frame	Slot number																
	0	1	2	3	4	5	6	7	8	9	10	11	12	13	14	15	16
0	T1	T2	T3	T4	T1	T2	T3	T4	T1	T2	T3	T4	T1	T2	T3	T4	B(S)
1	T1	T2	T3	T4	T1	T2	T3	T4	T1	T2	T3	T4	T1	T2	T3	T4	C1
2	T1	T2	T3	T4	T1	T2	T3	T4	T1	T2	T3	T4	T1	T2	T3	T4	C2
3	T1	T2	T3	T4	T1	T2	T3	T4	T1	T2	T3	T4	T1	T2	T3	T4	C3
4	T1	T2	T3	T4	T1	T2	T3	T4	T1	T2	T3	T4	T1	T2	T3	T4	C4
5	T1	T2	T3	T4	T1	T2	T3	T4	T1	T2	T3	T4	T1	T2	T3	T4	B(S)
6	T1	T2	T3	T4	T1	T2	T3	T4	T1	T2	T3	T4	T1	T2	T3	T4	C1
7	T1	T2	T3	T4	T1	T2	T3	T4	T1	T2	T3	T4	T1	T2	T3	T4	C2
8	T1	T2	T3	T4	T1	T2	T3	T4	T1	T2	T3	T4	T1	T2	T3	T4	C3
9	T1	T2	T3	T4	T1	T2	T3	T4	T1	T2	T3	T4	T1	T2	T3	T4	C4
10	T1	T2	T3	T4	T1	T2	T3	T4	T1	T2	T3	T4	T1	T2	T3	T4	B(S)
11	T1	T2	T3	T4	T1	T2	T3	T4	T1	T2	T3	T4	T1	T2	T3	T4	C1
12	T1	T2	T3	T4	T1	T2	T3	T4	T1	T2	T3	T4	T1	T2	T3	T4	C2
13	T1	T2	T3	T4	T1	T2	T3	T4	T1	T2	T3	T4	T1	T2	T3	T4	C3
14	T1	T2	T3	T4	T1	T2	T3	T4	T1	T2	T3	T4	T1	T2	T3	T4	C4
15	T1	T2	T3	T4	T1	T2	T3	T4	T1	T2	T3	T4	T1	T2	T3	T4	B(S)
16	T1	T2	T3	T4	T1	T2	T3	T4	T1	T2	T3	T4	T1	T2	T3	T4	C1
17	T1	T2	T3	T4	T1	T2	T3	T4	T1	T2	T3	T4	T1	T2	T3	T4	C2
18	T1	T2	T3	T4	T1	T2	T3	T4	T1	T2	T3	T4	T1	T2	T3	T4	C3
19	T1	T2	T3	T4	T1	T2	T3	T4	T1	T2	T3	T4	T1	T2	T3	T4	C4

**Table 7: Frame and super-frame organisation for an Ma channel with no free capacity**

Frame	Slot number																
	0	1	2	3	4	5	6	7	8	9	10	11	12	13	14	15	16
0	T1	T2	T3	T4	T5	T6	T7	T8	T1	T2	T3	T4	T5	T6	T7	T8	B(S)
1	T1	T2	T3	T4	T5	T6	T7	T8	T1	T2	T3	T4	T5	T6	T7	T8	C1
2	T1	T2	T3	T4	T5	T6	T7	T8	T1	T2	T3	T4	T5	T6	T7	T8	C2
3	T1	T2	T3	T4	T5	T6	T7	T8	T1	T2	T3	T4	T5	T6	T7	T8	C3
4	T1	T2	T3	T4	T5	T6	T7	T8	T1	T2	T3	T4	T5	T6	T7	T8	C4
5	T1	T2	T3	T4	T5	T6	T7	T8	T1	T2	T3	T4	T5	T6	T7	T8	B(S)
6	T1	T2	T3	T4	T5	T6	T7	T8	T1	T2	T3	T4	T5	T6	T7	T8	C5
7	T1	T2	T3	T4	T5	T6	T7	T8	T1	T2	T3	T4	T5	T6	T7	T8	C6
8	T1	T2	T3	T4	T5	T6	T7	T8	T1	T2	T3	T4	T5	T6	T7	T8	C7
9	T1	T2	T3	T4	T5	T6	T7	T8	T1	T2	T3	T4	T5	T6	T7	T8	C8
10	T1	T2	T3	T4	T5	T6	T7	T8	T1	T2	T3	T4	T5	T6	T7	T8	B(S)
11	T1	T2	T3	T4	T5	T6	T7	T8	T1	T2	T3	T4	T5	T6	T7	T8	C1
12	T1	T2	T3	T4	T5	T6	T7	T8	T1	T2	T3	T4	T5	T6	T7	T8	C2
13	T1	T2	T3	T4	T5	T6	T7	T8	T1	T2	T3	T4	T5	T6	T7	T8	C3
14	T1	T2	T3	T4	T5	T6	T7	T8	T1	T2	T3	T4	T5	T6	T7	T8	C4
15	T1	T2	T3	T4	T5	T6	T7	T8	T1	T2	T3	T4	T5	T6	T7	T8	B(S)
16	T1	T2	T3	T4	T5	T6	T7	T8	T1	T2	T3	T4	T5	T6	T7	T8	C5
17	T1	T2	T3	T4	T5	T6	T7	T8	T1	T2	T3	T4	T5	T6	T7	T8	C6
18	T1	T2	T3	T4	T5	T6	T7	T8	T1	T2	T3	T4	T5	T6	T7	T8	C7
19	T1	T2	T3	T4	T5	T6	T7	T8	T1	T2	T3	T4	T5	T6	T7	T8	C8

**Table 8: Frame and super-frame organisation for an La channel with no free capacity**

Slot number		0	1	2	3	4	5	6	7	8	9	10	11	12	13	14	15	16
Frame																		
0	T1	T2	T3	T4	T5	T6	T7	T8	T9	T10	T11	T12	T13	T14	T15	T16	B(S)	
1	T1	T2	T3	T4	T5	T6	T7	T8	T9	T10	T11	T12	T13	T14	T15	T16	C1	
2	T1	T2	T3	T4	T5	T6	T7	T8	T9	T10	T11	T12	T13	T14	T15	T16	C2	
3	T1	T2	T3	T4	T5	T6	T7	T8	T9	T10	T11	T12	T13	T14	T15	T16	C3	
4	T1	T2	T3	T4	T5	T6	T7	T8	T9	T10	T11	T12	T13	T14	T15	T16	C4	
5	T1	T2	T3	T4	T5	T6	T7	T8	T9	T10	T11	T12	T13	T14	T15	T16	B(S)	
6	T1	T2	T3	T4	T5	T6	T7	T8	T9	T10	T11	T12	T13	T14	T15	T16	C5	
7	T1	T2	T3	T4	T5	T6	T7	T8	T9	T10	T11	T12	T13	T14	T15	T16	C6	
8	T1	T2	T3	T4	T5	T6	T7	T8	T9	T10	T11	T12	T13	T14	T15	T16	C7	
9	T1	T2	T3	T4	T5	T6	T7	T8	T9	T10	T11	T12	T13	T14	T15	T16	C8	
10	T1	T2	T3	T4	T5	T6	T7	T8	T9	T10	T11	T12	T13	T14	T15	T16	B(S)	
11	T1	T2	T3	T4	T5	T6	T7	T8	T9	T10	T11	T12	T13	T14	T15	T16	C9	
12	T1	T2	T3	T4	T5	T6	T7	T8	T9	T10	T11	T12	T13	T14	T15	T16	C10	
13	T1	T2	T3	T4	T5	T6	T7	T8	T9	T10	T11	T12	T13	T14	T15	T16	C11	
14	T1	T2	T3	T4	T5	T6	T7	T8	T9	T10	T11	T12	T13	T14	T15	T16	C12	
15	T1	T2	T3	T4	T5	T6	T7	T8	T9	T10	T11	T12	T13	T14	T15	T16	B(S)	
16	T1	T2	T3	T4	T5	T6	T7	T8	T9	T10	T11	T12	T13	T14	T15	T16	C13	
17	T1	T2	T3	T4	T5	T6	T7	T8	T9	T10	T11	T12	T13	T14	T15	T16	C14	
18	T1	T2	T3	T4	T5	T6	T7	T8	T9	T10	T11	T12	T13	T14	T15	T16	C15	
19	T1	T2	T3	T4	T5	T6	T7	T8	T9	T10	T11	T12	T13	T14	T15	T16	C16	

The BCCH carried by slot type G2 and S1 shall only be transmitted by the GS. It shall provide information for the AS to make the decision as to which GS it should attempt to make connection to.

The BCCH is divided into two sub-channels as below:

- BCCH(S): supports synchronisation and layer 1 functions;
- BCCH(D): supports broadcast data for network entries for RRM for layer 3.

BCCH(S) shall be transmitted four times per super-frame in slot 16 on all carriers. BCCH(D) shall only be transmitted on the access carrier when traffic capacity is available. If no access carrier can be offered the BCCH(D) shall not be transmitted.

The RACH carried by slot type S2 shall be transmitted by the AS only in the same time-slot as S1 in the GS. In the case of handover the RACH shall be transmitted directly into the allocated traffic slot with the entry identity set to zero.

The IRCCH shall be carried by slot type G3 and transmitted by the GS only. The IRCCH shall have entry identity and power control set to zero on handover.

The RCCH shall be carried by slot type G3 and transmitted by the GS only. The RCCH shall obtain capacity from the DCCH, only in time-slot 16 as specified in subclauses 8.10 and 8.11.

The DCCH shall be carried by slot type G2 and transmitted by the AS and GS. This slot type may be transmitted in different slot positions. When transmitted in slot 16 of any frame it shall carry the SACCH. When transmitted in one of the slots 0 to 15, in place of the traffic channel TCH, it shall carry the FACCH.

The TCH shall be carried by slot type G1 and transmitted by the AS and GS.

The Idle Channel (ICH) shall be carried by slot type G3. It shall be transmitted by the GS in all unused timeslots with the timing offset field set to zero, and power control and entry identity fields set to "1".

#### 8.6.4 Timing requirements

The bit rate for transmission of information on the radio interface is defined in subclause 8.7.1.2. The reference location for network timing purposes shall be the GS. Within a super frame the GS transmission of slot 8 of frame 10 shall coincide with the GS reception of slot 0 of frame 0. Within a super frame the GS transmission of frame number 10 shall coincide with the GS reception of frame number 0.

NOTE: This mechanism is employed to improve the DCCH response times when La channels are used.

The system timing shall be controlled by the GS. The GS shall measure the arrival time of slots and transmit correction commands to the respective ASs as defined in subclause 8.11.4.

#### 8.6.5 Coding aspects

##### 8.6.5.1 G1 Slot

The 9,6 kbit/s speech codec frame of 192 bits shall be mapped directly onto the G1 slot without additional error correction being provided. Mapping and error correction for other traffic channel types are outside the scope of this ETS.

##### 8.6.5.2 G2 Slot

The layer 2 frames from BCCH(D) and DCCH shall be taken, twelve octets at a time, and coded and interleaved as specified in subclause 8.6.5.4.

##### 8.6.5.3 G3 Slot

The four octets of data specified in subclause 8.6.2.1.1, figure 12, shall be repeated twice producing twelve octets which shall then be Forward Error Correction (FEC) coded and interleaved as defined in subclause 8.6.5.4. After deinterleaving and FEC decoding, a majority vote decoder shall produce a declared good result for each field content if two or more of the received field contents agree. Figure 15 shows the bit mapping of the three data fields into the twelve octets before coding and interleaving as specified in subclause 8.6.5.4.



Figure 15: G3 Slot twelve octet data format

8.6.5.4 Coding and interleaving of G2 and G3 slots

The twelve octets of data defined in subclause 8.6.5.2 and 8.6.5.3 shall be forward error corrected using the extended Golay (23,12,3) code. The polynomial of the Golay (23,12,3) code shall be extended by the addition of an even parity bit to form the extended Golay (24,12,3) code. The polynomial shall be as follows:

$$g(X) = 1 + x^2 + x^4 + x^5 + x^6 + x^{10} + x^{11}$$

The encoding operation shall be:

$$c(X) = x^{11} m(x) + \{x^{11} m(x) \text{ modulo } g(x)\}$$

where c(X) and m(x) are the code and message polynomials.

The twelve octets of uncoded data are shown in figure 16. Figure 17 shows the eight Golay (24,12,3) coded blocks prior to the interleaving process.

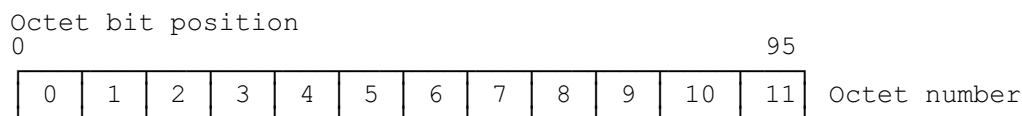
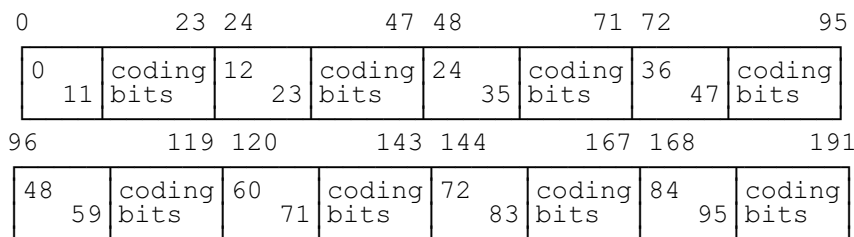


Figure 16: Input to Golay coder

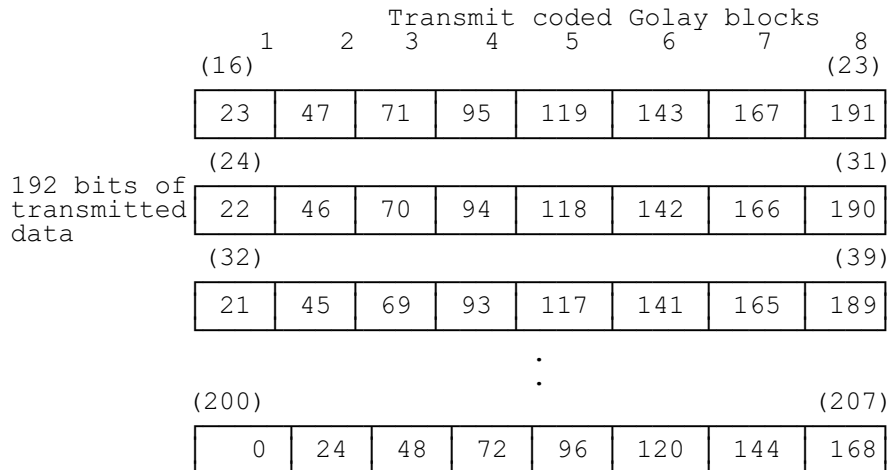


NOTE: Bit numbers within boxes indicate the bit position of the twelve octet input. Bit numbers external to each block indicate output bit position.

Figure 17: Output of Golay coder



The eight Golay coded blocks shall be vertically placed into the interleaving matrix as shown in figure 18 before being transmitted horizontally with bit 16 of the timeslot first (bit 0 of field c).

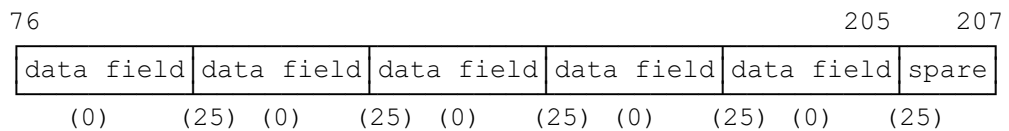


NOTE: Numbers in brackets indicate the location of bits in the transmitted G2 and G3 slots with the coded input bit sequence within boxes.

**Figure 18: Block interleaver**

**8.6.5.5 Coding of S1 slot**

The 26 bits of data defined in subclause 8.6.1 shall be repeated four times and mapped onto the S1 slot as shown in figure 19. A majority vote decoder shall declare a good result for each field content if three or more of the received field contents agree.



NOTE: The top numbers indicate the bit position in the transmitted S1 slot with bit 76 transmitted first. The numbers in brackets indicate the bit position for the data field specified in subclause 8.6.2.2.

**Figure 19: S1 Slot encoded data format**

**8.6.5.6 Coding of S2 slot**

The entry ID transmitted in the S2 slot shall not be error protected.

**8.7 Modulation characteristics**

This subclause contains the characteristics of the TDM/TDMA modulator and transmitter.

**8.7.1 General**

**8.7.1.1 Type of modulation**

The modulation method used shall be  $\mathcal{D}/4$  Differential Quadrature Phase Shift Keying ( $\mathcal{D}/4$  DQPSK). The modulation scheme shall use the phase constellation shown in figure 20.

Gray code shall be used for the modulator output mapping.

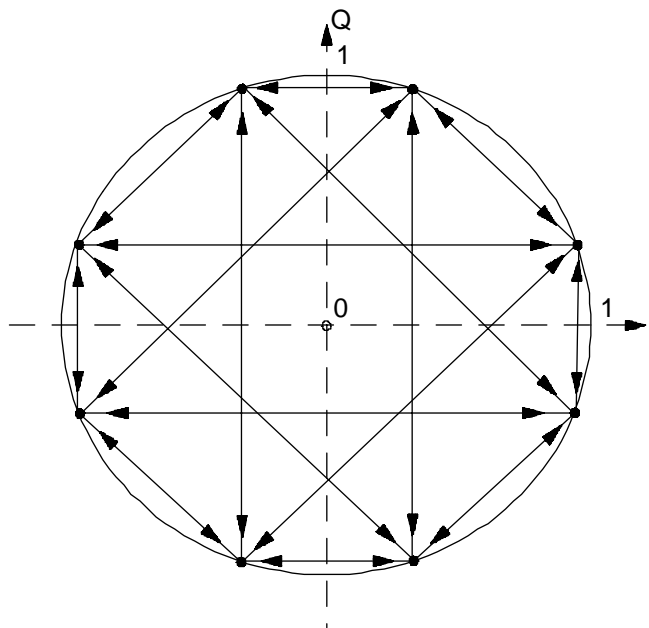


Figure 20:  $\pi/4$  DQPSK Constellation

**8.7.1.2 Channel transmission rate**

The channel transmission rate shall 44 200 bits/s.

**8.7.1.3 Data clock stability**

The incoming and outgoing modem clocks shall be derived from the same frequency reference as defined in subclause 8.8.1.3

**8.7.2 Modulator**

**8.7.2.1 Phase definition**

The input data to the modulator shall be differentially encoded. The symbolic output of the modulator shall be transmitted as changes in the phase angle and not as absolute phase values.

Data shall be serial to parallel converted to form two digital streams,  $A_k$  and  $B_k$ , commencing with numbered bits, 0 and 1, of the modulator input data stream.  $A_k$  shall comprise even bits and  $B_k$  odd bits.

For each dibit (i.e. bits 0 and 1 of the modulator data input stream) the associated symbol shall correspond to a phase change  $d\theta$ , and shall be determined in accordance with table 9.

**Table 9: Phase definition**

Transmitted symbol		Phase change $d\theta$
$A_k$	$B_k$	
1	1	+45°
0	1	+135°
0	0	-135°
1	0	-45°

A block diagram representing this process is shown in figure 21.

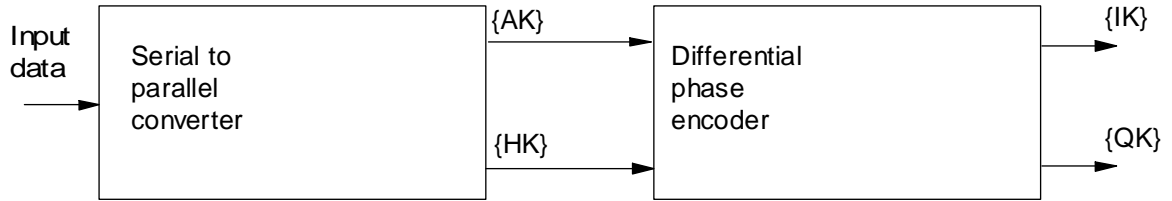


Figure 21: Phase encoding

The digital data sequences  $A_k$  and  $B_k$  shall be encoded on to  $I_k$  and  $Q_k$  vectors in accordance with the equations below:

where  $I_{k-1}$ , and  $Q_{k-1}$  are the magnitude of the previous I and Q vectors then:

$$I_k = I_{k-1} \cos \delta\theta_k - Q_{k-1} \sin \delta\theta_k; \text{ and}$$

$$Q_k = I_{k-1} \sin \delta\theta_k + Q_{k-1} \cos \delta\theta_k.$$

Impulses  $I_k$  and  $Q_k$  shall be applied to the inputs of the I and Q baseband filters (see figure 22).

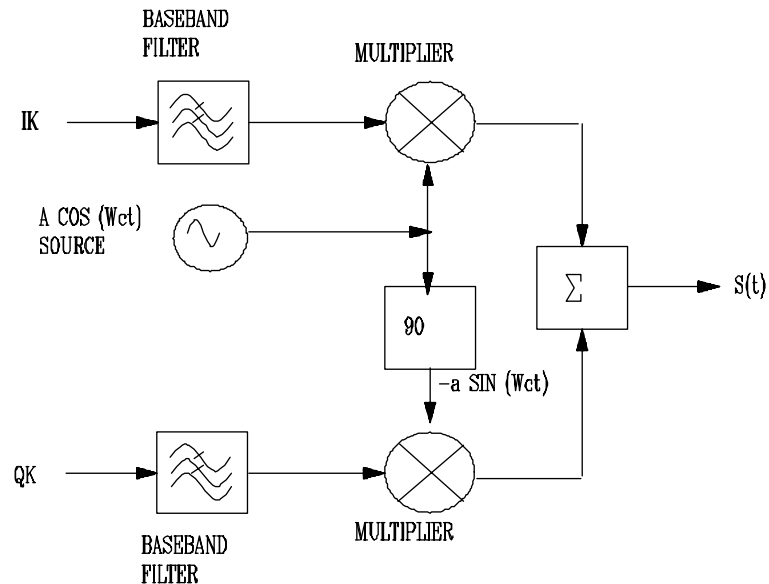


Figure 22: Modulation

### 8.7.2.2 Modulation filtering and modulated signal definition

Baseband filtering shall be close to ideal Nyquist with a square root raised cosine rolloff amplitude response of the form:

$$|H(f)| = \begin{cases} 1 & 0 \leq f \leq (1 - \alpha)/2T \\ \sqrt{\frac{1}{2}(1 - \sin(\pi(2fT - 1)/2\alpha))} & (1 - \alpha)/2T < f < (1 + \alpha)/2T \\ 0 & f > (1 + \alpha)/2T \end{cases}$$

where

$$0 \leq f \leq (1 - \alpha)/2T$$

$$(1 - \alpha)/2T < f < (1 + \alpha)/2T$$

$$f > (1 + \alpha)/2T$$

Where  $T$  is the symbol period,  $[\alpha]$  which determines the width of the transmission band shall be in the range 0,35 to 0,4.

The modulated spectrum within the frequency range  $\pm 0,5R$  ( $R =$  channel transmission rate) from the nominal carrier frequency shall fall within the mask shown in figure 23 and table 10 when its input is a Pseudo Random Binary Sequence (PRBS).

The total length of the PRBS should be more than  $10^6$  bits produced by a  $2^{15}-1$  PRBS sequence. The resultant modulated signal  $S(t)$  is given by:

$$S(t) = \sum_n g(t - nT) \cos \varphi_n \cos w_c t - \sum_n g(t - nT) \sin \varphi_n \sin w_c t$$

where:  $g(t)$  is the pulse shaping function specified in the frequency domain (see figure 23);

$w_c$  is the radian carrier frequency;

$T$  is the symbol period;

$\varphi_n$  is the absolute phase corresponding to the  $n^{\text{th}}$  symbol interval;

$$\varphi_n = \varphi_{n-1} + d\varphi.$$

Figure 23 shows the mask of the modulated spectrum. Table 10 gives the corresponding mask breakpoint co-ordinates. Outside the bandwidth  $\pm 0,5R$  from the nominal centre frequency the spectral density shall be at least - 54 dB/4 kHz below the peak spectral density. The filter history is not reset at the beginning of either the TDM or TDMA timeslot. Also, inactive TDMA timeslots shall contain data such that  $A_k$  and  $B_k$  defined in subclause 8.7.2.1 are zero.

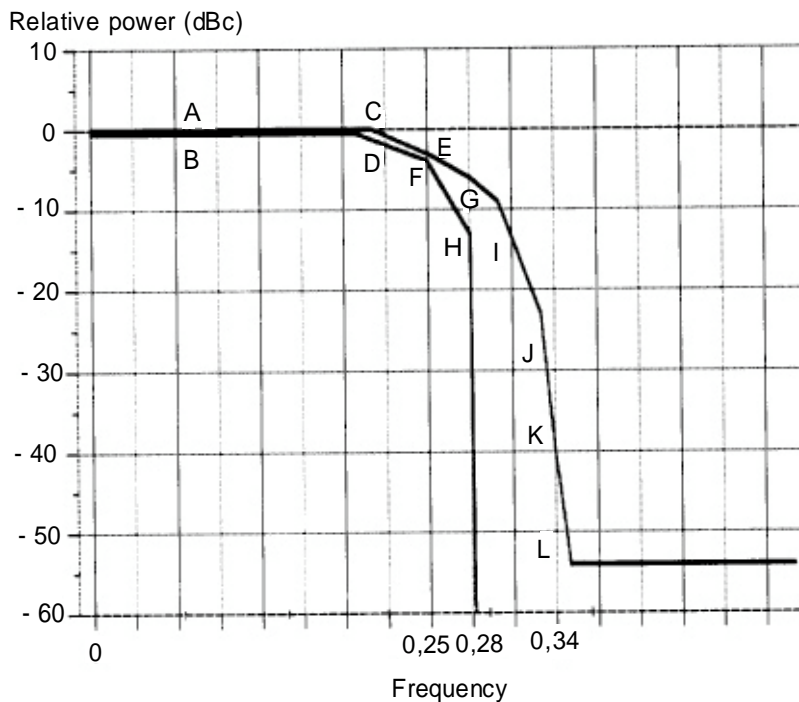


Figure 23: Spectral density mask at modulator output

**Table 10: Mask breakpoint coordinates**

Points	Frequency (Hz)	Normal Frequency (to bit rate R)	Amplitude (dB)
A	0	0,0	0,0
B	0	0,0	- 0,6
C	8 840	0,20	0,0
D	8 840	0,20	- 0,6
E	11 050	0,25	- 3,0
F	11 050	0,25	- 4,0
G	12 376	0,28	- 6,0
H	12 376	0,28	- 13,0
I	13 260	0,30	- 9,0
J	14 596	0,33	- 23,0
K	15 028	0,34	- 40,0
L	15 470	0,35	- 54,0
	> 15 470	> 0,35	- 54,0

**8.7.2.3 Modulator and transmitter accuracy**

The modulator and transmitter accuracy shall be specified by setting the limits on the root mean square (rms) difference between the actual transmitted waveform and the ideal waveform. The ideal waveform shall be derived mathematically from the specification of the modulation defined in subclause 8.7.2.1. The specified requirement shall be an error vector magnitude.

**8.7.2.3.1 Ideal case**

The definition of modulation is such that observing an ideal transmitter, through an ideal root raised cosine receiver filter, at the correct sampling instants, one symbol apart, would result in the sequence of values given as follows:

$$S(k) = S(k - 1) * e^{j(\pi/4 + X(k) * \pi/2)}$$

where  $X(k) = 0, 1, 2,$  or  $3,$  in accordance with table 11.

**Table 11: Modulation accuracy**

$A_k$	$B_k$	$X(k)$
1	1	0
0	1	1
0	0	2
1	0	3

In the forward channel (GS -> AS)  $S(k)$  forms part of a continuous data stream.

In the reverse channel (AS -> GS) the transmit bursts from the AS are truncated by power up and power down ramping. In this case, for a general slot type as described in subclause 8.6,  $S(2)$  is the first sample that enters into the demodulator which yields the first two information bits by comparing  $S(2)$  with  $S(3)$ . The last two information bits are obtained from comparing  $S(103)$  and  $S(104)$ .

The ideal transmit and receive filters, in cascade, form a raised cosine Nyquist filter having an impulse response going through zero at symbol period intervals so there is no inter symbol interference at the ideal sampling points. The ideal signal samples, therefore, take on one of the eight values defined in figure 20 at the output of the receive filter.

**8.7.2.3.2 Real case**

If  $Z(k)$  represents the complex vectors produced by observing the real transmitter through an ideal measuring receive filter at sampling times  $k$  one symbol apart, and if  $S(k)$  is defined as above, the transmitter is modelled as:

$$Z(k) = [C_0 + C_1 * [S(k) + E(k)]] * w^k$$

where:

$w^k = R(k) * e^{jkd\theta}$  accounts for both a frequency offset giving  $d\theta$  radians per symbol phase rotation and an envelope  $R(k)$ .

$C_0$  is a constant origin offset representing quadrature modulator imbalance.

$C_1$  is a complex constant representing the arbitrary phase and output power of the transmitter.

$E(k)$  is the residual error vector on sample  $S(k)$ .

$$\sum_{k_{min}}^{k_{max}} |E(k)|^2 = \sum_{k_{min}}^{k_{max}} | [Z(k) * w^{-k} - C_0] / C_1 - S(k) |^2$$

$C_0$ ,  $C_1$ , and  $w$  shall be chosen to minimise this expression (carrier phase synchronisation) and then used to compute the individual vector errors  $E(k)$  on each symbol. The symbol timing phase of the receiver output samples used to compute the vector error shall be chosen to give the lowest value (symbol timing synchronisation). The values of  $k_{max}$  and  $k_{min}$  for AS -> GS or GS -> AS are:

$$k_{min} = 3 \text{ and } k_{max} = 104$$

The root mean square vector is then:

$$\epsilon_{RMS} = (k_{max} - k_{min})^{-1} * \left( \sum_{k_{min}}^{k_{max}} |E(k)|^2 \right)^{0,5}$$

and shall be less than 0,14 in any burst.

The magnitude of  $C_0$  (origin offset) shall be less than 0,05. This value is referred to the magnitude of  $C_1$ .

The rms vector magnitude does not take into account only modulation filtering linear distortion (amplitude and phase transmit and receive filters) or modulation impairments (quadrature offset phase and amplitude errors of the modulation states) but is a measure of the transmitter/receiver quality. It takes into account also the local oscillator phase noise, complementary filter distortion and power amplifier non linearity.

**8.7.2.4 Scrambler**

In order to get a flat transmitted spectrum without pronounced spectral components the spectrum shall be spread using a scrambler which prevents the presence of long sequences of 0 or 1.

The scrambling shall be applied in both directions to field C on slot types G1, G2 and G3 only.

This shall be achieved by the modulo 2 addition of a maximal length PN sequence to the time-slot data before modulation, but after Golay coding. The code polynomial for the PN sequence shall be:

$$PN(X) = 1 + X + X^4 + X^6 + X^{12}.$$

The PN sequence shall be initialised at the beginning of every transmitted frame to state octal 0115 and shifted for every data bit in the frame.

## **8.8 Radio transmission and reception characteristics**

### **8.8.1 General characteristics**

#### **8.8.1.1 Channelling**

The main receiver of the equipment shall be tuned to the receive channel corresponding to the transmit channel. The scanning receiver shall be capable of being tuned to any of the receive channels.

##### **8.8.1.1.1 Frequency range**

Two frequency bands of 5 MHz each have been allocated at WARC-92 for terrestrial APC. The frequency range for terrestrial Aeronautical Public Correspondence (APC) is as follows:

1 670 to 1 675 MHz for ground to air use;

1 800 to 1 805 MHz for air to ground use.

##### **8.8.1.1.2 Radio frequency channel arrangement**

The TFTS radio frequency channel arrangement provides for 164 pairs of RF channels (one for each direction of transmission). The centre frequencies of these channels are given by the following:

$$F_g(n) = 1\,670 + n/33 \text{ MHz};$$

$$F_a(n) = F_g(n) + 130 \text{ MHz};$$

where:

$F_g(n)$  is the frequency of the  $n^{\text{th}}$  ground transmit channel;

$F_a(n)$  is the frequency of the  $n^{\text{th}}$  airborne transmit channel;

$n$  is the channel number (1 to 164).

##### **8.8.1.2 Channel selection time**

A change of channel made during operation shall not result in a loss of synchronisation in either direction for more than 100 ms.

Transmission shall be inhibited unless the receiver frequency synthesizer is correctly tuned to the selected receive frequency.

##### **8.8.1.3 Frequency stability**

###### **8.8.1.3.1 AS**

The fractional error between the actual transmitted frequency or the centre frequency of the receiver and the nominal frequency shall be less than  $2 \cdot 10^{-7}$ .

###### **8.8.1.3.2 GS**

The fractional error between the actual transmitted frequency or the centre frequency of the receiver and the nominal frequency shall be less than  $4 \cdot 10^{-8}$ .

#### 8.8.1.4 Modulation

The modulation characteristics are described in subclause 8.7.

#### 8.8.2 Transmitter

##### 8.8.2.1 Polarisation

Emissions shall be vertically polarised.

##### 8.8.2.2 Radiated power

###### 8.8.2.2.1 AS

Adaptive power control of the transmitter shall be provided in the AS. The GS may request AS transmitter power level adjustments to maintain an adequate receive signal at the GS.

The AS shall provide a nominal transmit power of + 40 dBm at the antenna port, with a tolerance of + 2 dB - 1 dB, when measured using a passive 50 ohm load termination. The test configuration shall include the diplexer and cable losses. It shall be possible to adjust the transmit power in the range of + 0, - 75 dB relative to the nominal transmit power specified above in 15 equal steps (ie 16 levels) of 5 dB (a step is defined as the interval between adjacent levels).

The power control step progression shall be monotonic and the tolerance on each step shall be  $\pm 2$  dB. The lowest transmit power shall be - 75 dB  $\pm 2$  dB relative to the nominal transmit power.

NOTE: The above test configuration has assumed a cable loss between the output of the power amplifier and the antenna port of 3 dB and a diplexer insertion loss of 1 dB.

###### 8.8.2.2.2 GS

The e.i.r.p. defined in this ETS is consistent with the antenna gain characteristic of subclause 8.9.

NOTE: The e.i.r.p. stated in the following parts of this subclause assume a site configuration with a cable loss of 1.5 dB between the transmitter output and the antenna. e.i.r.p. values may require adaption for the radio engineering of specific sites.

###### 8.8.2.2.2.1 En Route GS (ERGS)

The e.i.r.p. in the horizontal plane shall be a nominal value of + 49 dBm. The tolerance at the nominal level of + 49 dBm shall be + 3, - 0 dB. A lower e.i.r.p. may be required for local radio site engineering reasons. At all other levels the tolerance for the e.i.r.p. shall be  $\pm 2$  dB.

###### 8.8.2.2.2.2 Intermediate GS (INTGS)

The e.i.r.p. in the horizontal plane shall be a nominal value of + 39 dBm. The tolerance at the nominal level of + 39 dBm shall be + 3, - 0 dB. A lower e.i.r.p. may be required for local radio site engineering reasons. At all other levels the tolerance for the e.i.r.p. shall be  $\pm 2$  dB.

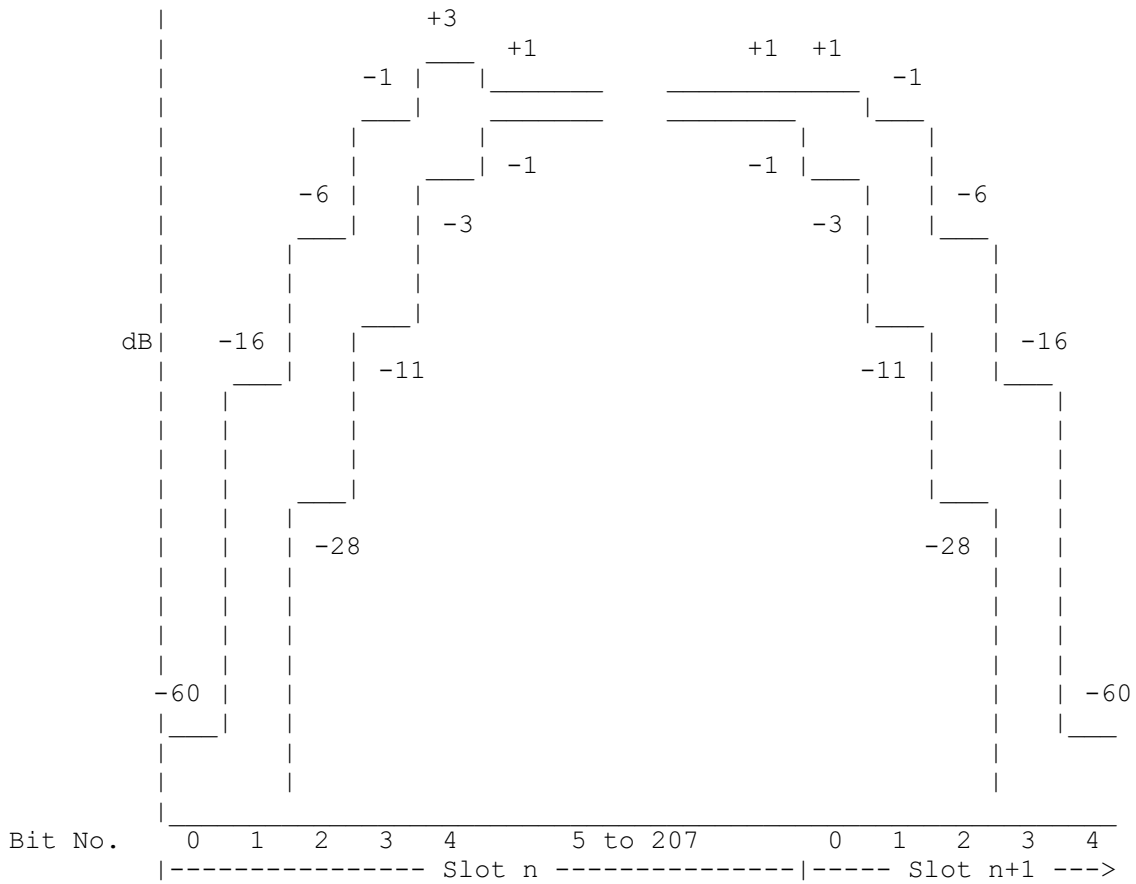
###### 8.8.2.2.2.3 Airport GS (APGS)

The e.i.r.p. in the horizontal plane shall be a nominal value of + 39 dBm. The tolerance at the nominal level of + 39 dBm shall be + 3, - 0 dB. A lower e.i.r.p. may be required for local radio site engineering reasons. At all other levels the tolerance for the e.i.r.p. shall be  $\pm 2$  dB.



**8.8.2.3 Power ramping procedure**

The transmitter RF power output shall lie within the boundaries shown in figure 24.



**Figure 24: Rise and fall time mask**

The power output during the guard bits between active and inactive slots shall be controlled to minimise spectral spreading and shall generally conform to a raised cosine shape where:

- the application of power between inactive and active slots shall take place during the period within bits 1 to 4 inclusive;
- the removal of power between active and inactive slots shall take place during the period within bits 0 to 3 inclusive;
- the power between contiguous transmitted slots shall not be ramped.

NOTE: The maximum and minimum levels of RF power output during each bit time of a slot are given. Levels are defined relative to the actual RF power output.

#### 8.8.2.4 RF spectrum mask

The output spectrum shall fall within the spectrum mask defined by joining the points listed in table 12 with straight lines. The output spectrum shall be measured with the transmitter modulated by a non-return-to-zero bit stream. The total length of the bit stream shall be more than  $10^6$  bits produced by a  $2^{15} - 1$  pseudo random sequence generator. Frequency shall be measured from the nominal transmitter frequency and amplitude from the power level at the nominal transmitter frequency.

**Table 12: RF spectrum mask**

Frequency, kHz	Level, dB
+/- 11,3	+ 01
+/- 14,5	- 20
+/- 15,6	- 35
+/- 30,0	- 37
+/- 60,0	- 49
+/- 120,0	- 65
+/- 2 500,0	- 70
+/- 5 000,0	- 75

It is recommended that manufacturers should aim to improve the performance of their equipment such that the relative output level at  $\pm 120$  kHz is reduced from - 65 dB to - 68 dB.

#### 8.8.2.5 Out of band emissions

TFTS transmitters shall meet or exceed the following out of band specifications at  $> \pm 2,5$  MHz outside the allocated frequency band:

- better than - 68 dBw/30 kHz at the AS to protect fixed services;
- better than - 60 dBw/MHz at the GS to protect meteorological (1 690 to 1 710 MHz) and other services;

TFTS ASs shall be limited to + 26 dBm for all channels when weight on wheels is true to protect DCS 1800 services. It is recommended that careful attention is given to the planning of TFTS airport station frequencies which are in the vicinity of DCS 1800 users.

#### 8.8.2.6 Spurious emissions

Spurious emissions conditions specified in this ETS shall be consistent with the definition of spurious emissions and the other conditions given for spurious emissions in ETS 300 086 [35], clause 7.

For frequencies between 9 kHz and 1 GHz the spurious emissions from TFTS equipment shall not exceed - 57 dBm. For frequencies between 1 GHz and 12,75 GHz the spurious emissions from TFTS equipment shall not exceed - 47 dBm.

#### 8.8.2.7 Modulation accuracy

The modulation accuracy defined in subclause 8.7.2.3 shall be met at the transmitter output.

### 8.8.3 Receiver

#### 8.8.3.1 Frequency offsets

Due to the effects of Doppler shifts and transmitter frequency errors the input signals at the receiver may be offset by up to 2,1 kHz from the receiver tuned frequency. The minimum requirements in the following subclauses for the propagation model (a) only, shall be met with both the wanted and unwanted signals offset by any value of doppler shift (within the range  $\pm 1,8$  kHz for the GS and  $\pm 1,67$  kHz for the AS) in addition to the worst local oscillator errors for the specified equipment implementation.

NOTE: While the airborne receiver is presented with a signal which may vary at up to 100 Hz/second the ground receiver input is subject also to a differing frequency offset in each slot.

### 8.8.3.2 Static propagation conditions

An input signal from a source at zero degrees elevation relative to the receive antenna, modulated by a  $2^{15}$  - 1 pseudo random bit stream generator and of at least  $10^6$  bits in length, producing a vertically polarised Power Flux Density (PFD) of - 113 dBW/m<sup>2</sup> at a 1 dBi airborne station antenna, or - 121 dBW/m<sup>2</sup> at a 8 dBi GS reference antenna, or - 113 dBW/m<sup>2</sup> at a 0 dBi GS reference antenna, shall give a BER of  $10^{-3}$  or better at the demodulator output under each of the following conditions:

NOTE: The PFD levels quoted above are based on system design criteria of:

AS	Antenna gain	1 dB;
	Feeder loss	3 dB;
	Diplexor loss	1 dB;

Resultant power in receiver - 112 dBm;

GS	Antenna gain	8 dB;
	Feeder loss	1.5 dB;
	Diplexor loss	1 dB;

Resultant power in receiver - 112 dBm.

#### 8.8.3.2.1 Without interferer

An input signal from a source at zero degrees elevation relative to the receive antenna, modulated by a  $2^{15}$  - 1 pseudo random bit stream generator and of at least  $10^6$  bits in length, producing a vertically polarised Power Flux Density (PFD) of - 113 dBW/m<sup>2</sup> at a 1 dBi airborne station antenna, or - 121 dBW/m<sup>2</sup> at a 8 dBi GS reference antenna, or -113 dBW/m<sup>2</sup> at a 0 dBi GS reference antenna, shall give a BER of  $10^{-3}$  or better at the demodulator output.

The difference in PFD for a BER of  $10^{-3}$  and  $10^{-6}$  shall not be greater than 7 dB.

#### 8.8.3.2.2 With an interferer created by the intermodulation of two interfering signals

The two unmodulated interfering signals 55 dB above the wanted signal, spaced 6 channels and 12 channels from the wanted signal shall give a BER of  $5 \times 10^{-3}$  or better at the modulator output. Both interfering signals shall be on the same side of the wanted signal.

The required PFD shall be as specified in subclause 8.8.3.2.1.

#### 8.8.3.2.3 With adjacent interferer: TDM at the AS receiver and TDMA (uniform timeslot level) at the GS receiver.

An interfering signal spaced n channel(s) from the wanted signal, modulated by a pseudo random bit stream of  $10^6$  bits in length and differing from the wanted signal, shall give a BER of  $5 \times 10^{-3}$  or better at the demodulator output. The interferer level (C/I) is as shown in table 13 below.

**Table 13: Interferer level**

n	C/I (dB)
0	+20
1	-20
2	-34
3	-38
4	-40
8	-40

NOTE:  $dF = n \times 30,30 \text{ kHz}$

The required PFD shall be as specified in subclause 8.8.3.2.1.

**8.8.3.2.4 With co-channel TDMA interferer: variable timeslot level for GS receiver**

A co-channel interferer signal, modulated by a pseudo random bit stream of  $10^6$  bits in length, which differs from the wanted signal and is 25 dB above the wanted signal, constituted by a complementary frame with the wanted signal frame, shall give a BER of  $5 \times 10^{-3}$  or better at the demodulator output.

The required PFD shall be as specified in subclause 8.8.3.2.1.

**8.8.4 Dynamic propagation conditions**

Details of the propagation models and their derivation are given in subclause 8.8.4. The information included in this subclause is informative.

Three cases are chosen as the most rigorous:

- A) en-route flight at 600 kts as listed in subclause 8.8.5.3.3;
- B) take off/landing at 120 kts as listed in subclause 8.8.5.3.2 a);
- C) taxiing between buildings at 20 kts as listed in subclause 8.8.5.3.1 b).

NOTE: The GS PFD defined in this ETS are consistent with the antenna gain specification of subclause 8.9 and with 1,5 dB feeder loss between the GS antenna and the GS access. The PFD values may be adapted to the actual antennae, site and installation conditions.

**8.8.4.1 Basic BERs**

The specified input signals from a source at zero degrees elevation relative to the receive antenna, modulated by a  $2^{15} - 1$  pseudo random bit stream generator and at least  $10^6$  bits in length, producing a vertically polarised PFD specified below at a receive antenna, shall give a BER of  $10^{-2}$  or better at the demodulator output under each of the following conditions:

Model	GS PFD	AS PFD
A	- 125 dBW/m <sup>2</sup>	- 117 dBW/m <sup>2</sup>
B	- 123 dBW/m <sup>2</sup>	- 115 dBW/m <sup>2</sup>
C	- 117 dBW/m <sup>2</sup>	- 109 dBW/m <sup>2</sup>

and at all signal levels in the range + 1 dB to + 70 dB greater than the levels above.

NOTE: The data for model A give the required performance for the underlying channel model. Network planning may require a signal 5 dB or more above these values, to cope with multi path fading, which is not included in this model.

#### 8.8.4.2 BERs with interfering signals

With the signal levels listed below, the requirements of subclause 8.8.4.1. shall be met in the presence of an interfering signal in the adjacent channel modulated with a bit stream asynchronous to the wanted signal and 30dB higher in level.

Model	GS PFD	AS PFD
A	- 121 dBW/2	- 113 dBW/m2
B	- 119 dBW/m2	- 111 dBW/m2
C	- 114 dBW/m2	- 106 dBW/m2

NOTE: The data given for model A give the required performance for the underlying channel model. Network planning may require a signal 5 dB or more above these values, to cope with multi path fading, which is not included in this model.

#### 8.8.4.3 GS receivers

A receiver intended for GS use shall meet the requirements of subclauses 8.8.4.1 and 8.8.4.2 with an input made up of two differing pseudo random bit streams transmitted in alternate slots. The required BER of  $10^{-2}$  shall be met for each input with the two signal levels differing by 30 dB.

### 8.8.5 Propagation models

#### 8.8.5.1 General

In mobile communications the signal received by a moving station is usually strongly affected by the surrounding environment, (i.e. natural and man made obstacles, hills and buildings seldom allow a line of sight path between transmitter and receiver to be established on the ground). As a consequence, at the mobile station the signal usually consists of multi-path components due to diffusion, diffraction and scattering. The random relative position of the mobile station with respect to these obstacles does not provide a satisfactory deterministic propagation model and therefore a statistical approach to determine the channel characterisation may be used.

For the purposes of simulation this subclause defines a set of propagation models in the following terms:

- a) a discrete number of taps of a transversal filter defined by a time delay and attenuation;
- b) the Doppler spectrum to be presented at each output.

#### 8.8.5.2 Doppler spectrum types

Four types of Doppler spectra are defined, which will be used for the modelling of the channel.

The following definitions are used:

$f_d = v/(c/f)$ , represents the maximum Doppler shift, with  $v$  (m/s) representing the AS speed, and  $c/f$  (in m) the wavelength;

$k = 10 \log(P_d / P_s)$ , with  $P_d$  representing the power of the deterministic direct path, and  $P_s$  the power of the random multi-path component;

$a_d$  represents the angle between the main component arrival direction and the mobile station direction.

- a) The CLASSical (CLASS) spectrum is the classical Doppler spectrum, resulting from multi-path components only. The angles of incidence of the incoming multi-path components are assumed to be uniformly distributed.

The CLASS spectrum is fully characterised by  $f_d$ .

- b) The SECTional (SECT) spectrum results from the CLASS spectrum, when the angles of incidence of the incoming multi-path components are thinly distributed (e.g. multi-path components scattered by one major natural or man made obstacle).

The relative position, the dimension, and the shape of the obstacle influence the mean value of the incidence angles and their spread and consequently the width of the sectional spectrum and its centre frequency. In the first approximation the bandwidth can be assumed to be in the order of  $0,1 f_d$ . As far as the centre frequency is concerned, an incidence angle of the multi-path components of 45 degrees can be assumed as representative of a typical average situation, resulting in a centre frequency at approximately  $0,7 f_d$  from the carrier frequency.

- c) The RICE spectrum results from a CLASS spectrum and one direct path. The value of the angle  $a_d$  is irrelevant to the overall statistical behaviour; also in this case an angle of 45 degrees can be assumed as representative of a typical average situation.

The RICE spectrum is fully characterised by  $f_d$ ,  $k$ , and  $a_d$ .

- d) The IMPulse (IMP) spectrum results from the RICE spectrum, when only the direct path is present (i.e. as  $k$  tends to infinity, however in practice when  $k > 20 - 30$  dB). Consequently, it takes the form of a Dirac impulse. The position of such an impulse depends on  $a_d$ , which can be assumed to be 45 degrees, so that the impulse results at about  $0,7 f_d$  from the carrier frequency.

NOTE: The RICE spectrum, together with the parameters  $f_d$ ,  $k$  and  $a_d$  includes all the Doppler spectra defined above.

**8.8.5.3 Models**

The models are described in subclauses 8.8.5.3.1, 8.8.5.3.2 and 8.8.5.3.3 in terms of delay and attenuation. Values are given for all cases as developed, but it is not necessary in practice to generate the values below - 20 dB as the effect of these will be negligible. Also due to the gross bit rate specified for TFTS, the contribution to the propagation model definition of multi-path components characterised by relative time delays less than 5  $\mu$ sec can be considered negligible.

**8.8.5.3.1 Airport manoeuvring**

- a) Open scenario

This model consists of a Rice spectrum; the Doppler frequency chosen corresponds to a speed of 20 kts.

Tap No.	Relative time delay ( $\mu$ sec)	Average relative power (dB)	Doppler spectrum $f_d = 53$ Hz
1	0	0	RICE $k = 6$ dB

- b) Badly obstructed

In this case the direct path is considered not to be present.

Tap No.	Relative time delay ( $\mu$ sec)	Average relative power (dB)	Doppler spectrum $f_d = 53$ Hz
1	0	0	CLASS

**8.8.5.3.2 Take-off**

a) On runway

This model consists of a Rice spectrum; the Doppler frequency corresponds to an AS speed of 120 kts.

Tap No.	Relative time delay (µsec)	Average relative power (dB)	Doppler spectrum fd = 320 Hz
1	0	0	RICE k = 6 dB

b) Climbing clear of the ground

This model consists of the impulse spectrum only; the Doppler frequency corresponds to a AS speed of 200 kts.

Tap No.	Relative time delay (µsec)	Average relative power (dB)	Doppler spectrum fd = 530 Hz
1	0	0	IMP

**8.8.5.3.3 In-flight**

The following model has to be considered; the Doppler frequency corresponds to an AS speed of 540 kts (1000 km/hr).

Tap No.	Relative time delay (µsec)	Average relative power (dB)	Doppler spectrum fd = 1,6 kHz
1	0	0	IMP

NOTE:  $f_d$  is calculated as per subclause 8.8.4.2 plus the worst case opposing oscillator drifts. It is important in this case, as the wanted signal is drifting out of the pass band while the unwanted is drifting into the pass band.

**8.9 GS antenna characteristics**

**8.9.1 General**

The GS provides direct communication with ASs. The transmission between the ground and the aircraft may be established both when the aircraft is on the ground and when flying. The range of aircraft altitudes and diversity of propagation environments lead to the definition of three types of GSs as follows:

- airport;
- intermediate;
- en-route.

**8.9.2 Common characteristics for all GS types**

**8.9.2.1 Frequency range**

GS antennas shall operate in the transmission and reception frequency bands as defined in subclause 8.8.1.

**8.9.2.2 Polarisation**

The antennas shall be vertically polarised.

**8.9.2.3 Energy acceptance capability**

The gain characteristics should compensate for any mismatch between the transmitter, the receiver and the antenna feeder.

**8.9.3 Specific characteristics for each type of GS**

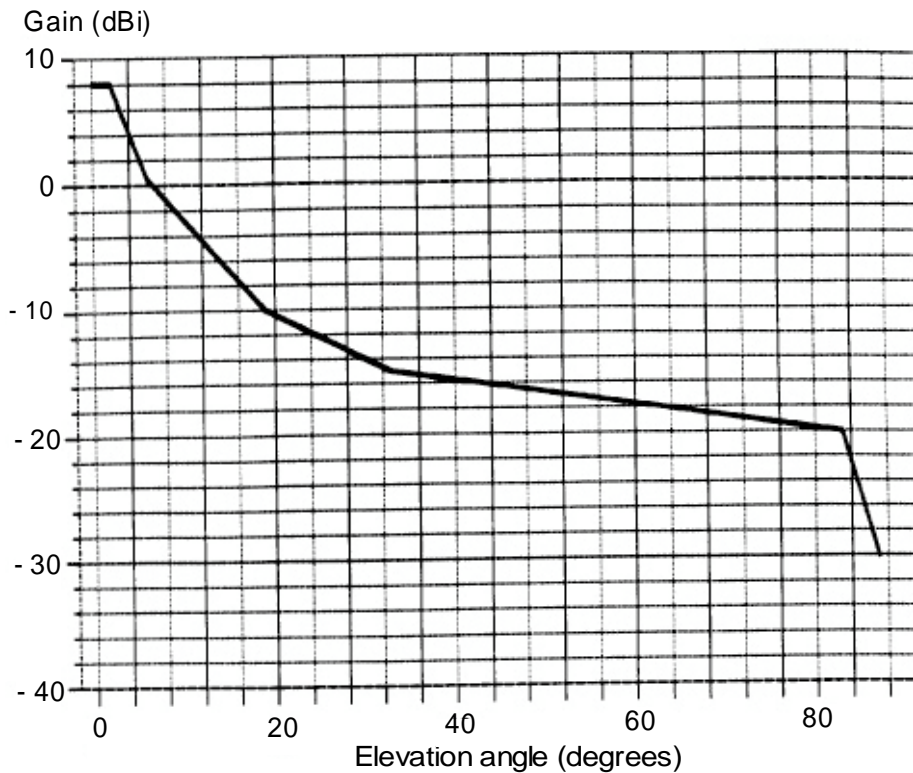
**8.9.3.1 Radiation patterns**

**8.9.3.1.1 En route stations**

The elevation angles are referenced to the horizontal plane.

Positive elevation angles: due to the polarization and the omnidirectional nature of the antennas, a null will be formed close to the vertical directly above the antenna. The antenna minimum gain with elevation characteristic is given in figure 25.

For negative elevation angles the value of gain shall not exceed the value of the gain for the corresponding positive angle.



**Figure 25: ERGS antenna**

The value of antenna gain is calculated as the average of the gain in dBi obtained considering all the azimuths between 0 and 360 degrees. The average value of the gain at the horizon (ie 0 degree elevation) shall not be less than 8 dBi. The minimum value of the gain shall never be less than 7.5 dBi for any direction. Each en-route application will require careful evaluation to ensure adequate coverage. The type of antenna may need to be site specific.

The requirements of intermediate stations and airport stations will depend upon the coverage required by these stations and will be determined during implementation. For this reason the requirements are not specified in this ETS.



### **8.9.3.1.2 Intermediate stations**

The requirements are the same as those specified in subclause 8.9.3.1.1 for an En-Route Ground Stations (ERGS).

### **8.9.3.1.3 Airport stations**

The airport station antenna shall have a sufficient gain with elevation characteristic to ensure adequate coverage on the manoeuvring area of the airport. Each airport application may need careful evaluation to ensure adequate coverage. The requirements are not specified in this ETS for this reason.

### **8.9.3.2 Antenna height**

The antenna shall be mounted so that the mask defined in subclause 8.9.3.1 is complied with at antenna heights above 3 metres.

## **8.10 Radio sub-system link control**

### **8.10.1 General**

The radio sub-system aspects that are addressed in this ETS are as follows:

- handover;
- RF power control;
- timing control;
- cell selection and re-selection.

Handover shall maintain a call in progress as an AS passes from the coverage of one GS to that of another and may also be employed to meet network management requirements, e.g. "balancing", to relieve congestion.

Handover may take place between one GS and another, between two slots in the same carrier, between two carriers on one GS or between two co-sited GS (e.g. airport to Terminal Manoeuvring Area (TMA) coverage).

Adaptive control of the RF transmit power from an AS shall be implemented in order to optimise the system performance and minimise the effects of co-channel interference in the system.

The criteria for radio failure are specified in order to ensure that calls which fail either from loss of radio coverage or unacceptable interference are satisfactorily handled by the network.

This subclause describes the functions that shall be performed for satisfactory control of the radio channel. It does not address the layer responsible for the activity. Throughout this subclause, range will be defined in kilometres (km), and to comply with aeronautical conventions the height of the AS will be defined in feet (ft).

### **8.10.2 Handover general**

#### **8.10.2.1 Overall process**

The handover process shall be implemented in the AS and GS. The AS makes handover decisions based on the range derived from the TDM and other criteria related to the flight state of the AS or broadcast on the BCCH. Slot to slot and carrier to carrier handover shall only take place on the request of the GS. GS to GS handover shall take place on request of the AS.

The categories of handover are shown in table 14.

**Table 14: Handover categories**

Slot to slot	This is the simplest form.
Carrier to carrier	This is the transfer from one carrier to another on the same GS. This case is used to allow the system to minimise blocking.
GS to GS	This is the case of full handover. It covers for example the cases of handover between en route and en route stations and between en route and intermediate stations.

### **8.10.2.2 Decision strategy for GS to GS handover**

Details of actions to be taken by the AS in various states is found in subclause 8.10.6.3. The following subclause gives an outline of the underlying logic governing the strategy.

#### **8.10.2.2.1 Primary handover decision**

a) between types of station:

the decision to access an Airport (AP), Intermediate (INT), or En-Route (ER) station is based on information received from aircraft systems. The decision structure is defined in subclause 8.10.6.3. Care needs to be taken on aircraft take off, to limit the time allowed for transfer between types of stations. Continuation of transmission by the AS on AP or INT frequencies above the design altitudes may cause interference to adjacent co-channel stations. Subclause 8.10.6.3 describes two procedures covering these cases with and without aircraft altitude information;

b) between en route stations:

the basic strategy for an AS to progress along a chain of ER stations is to continually seek that ER station towards which the AS is approaching with the highest velocity, within the confines of the cell range limit, as this will minimise the number of handovers. The velocity of approach towards an object is hereafter called "Closing Rate" (CR).

### **8.10.3 R.F. power control**

#### **8.10.3.1 Purpose**

The RF power transmitted by the AS shall be controlled by instruction from the GS using the control field given in subclause 8.6.2.1.1. This facility shall be used by the GS in order to minimise radiated power from the AS and reduce interference at the GS. Details of the implementation within the radio equipment are outside the scope of this ETS.

#### **8.10.3.2 Timing**

When a request for power change is received by an AS, power shall be incremented or decremented at one 5 dB step per frame until the requested change is complete. The request shall take the form of a number representing the absolute power level as defined in subclause 8.6.2.1.1.

The format for the power control message is defined in subclause 8.6.2.

#### **8.10.3.3 Initial exchanges**

Descriptions of the processes for initial system exchanges can be found in subclauses 8.5.3 and 8.5.4.

### **8.10.4 RF power control at call initiation**

The AS shall use the radio channel offered on the BCCH(S) to enter the system.

The AS shall read the BCCH(D) on this carrier, and measure the received signal level. It shall then decode the next BCCH(S) slot and, if the negotiation slot and access carrier are correctly decoded as specified in subclause 8.6.2.2.1, start the access transaction by sending a S2 slot in the down link counter part of the BCCH(S).

Further details on the access transaction are given in subclause 8.5.

The access request shall succeed when a G3 slot for the IRCCH is received in the negotiation slot with the correct entry identity.

If a response containing an incorrect entry identity is received or if the sequence is completed with no response, the attempt is considered to have failed.

A random number, between 0 and 7 inclusive, of entry opportunities shall then be missed before the next entry attempt may be made.

A new random number shall be selected for entry identity between each entry attempt (see subclause 8.5.3).

A total of up to four entry attempts shall be made using this routine with the S2 slot transmitted at a power level according to the following sequence:

- 1 S2 at initial level;
- 2 S2 at initial level;
- 3 S2 at 10 dB higher than initial level;
- 4 S2 at 10 dB higher than initial level.

The initial power level shall be calculated from the formula:

$$P_{ac} = PGS - (R_{ac} - R_{min}); (+5, -0) \text{ dBm}$$

where:

- $P_{ac}$  is the AS transmit level;
- $PGS$  is the GS transmit level;
- $R_{ac}$  is the received signal level;
- $R_{min}$  is the minimum receive level at the GS obtained by the addition of  $R_{MIN}$  to - 115 dBm.

During the whole duration of the access procedure the AS shall monitor the access channel and negotiation slot transmitted on the BCCH(S). If the access carrier changes, the AS shall terminate the current access procedure, tune to the new access carrier and restart.

If the access procedure fails it may be repeated up to three times. If several acceptable GS are detected, different attempts should preferably use different GSs.

### **8.10.5 Handover procedure**

To establish a link to a new GS, or a new carrier, on handover the initial transmit level shall be + 5 dB above the power defined in subclause 8.10.4 (where  $R_{ac}$  relates to the new carrier).

The first slot of each frame allocated by the new GS shall contain an S2 slot for the RACH, while the remaining slots shall carry TCH or DCCH. The following sequence of frames shall be transmitted:

- 1) S2 slot plus associated slots at the initial level;
- 2) S2 slot plus associated slots at the initial level;
- 3) S2 slot plus associated slots at 10 dB higher than the initial level;
- 4) S2 slot plus associated slots at 10 dB higher than the initial level.

The sequence shall terminate when a G3 slot is received. If this is not received by the end of the sequence, reversion shall occur to the old GS channel. The same sequence shall be transmitted. Failure to receive a response shall result in call termination.

### **8.10.6 Cell selection and re-selection**

#### **8.10.6.1 Overall process**

Whilst the AS is not communicating with any GS (idle state) an AS shall implement the GS selection process described in this subclause. These procedures shall apply for both call set up and handover.

#### **8.10.6.2 Reception of broadcast information**

On initialisation an AS should scan all the carriers until it finds a usable signal. It should then decode the data of the synchronisation channel BCCH(S), re-tune to the indicated access channel and read the data of the BCCH(D).

The BCCH(D) data shall include a set of primary frequencies, one for each cell surrounding the monitored cell this gives the AS knowledge about one, arbitrarily chosen, frequency used at a new cell). No special significance is given to the primary frequency, as the access carrier and the BCCH(D) location shall be separately indicated by the BCCH(S) present on each carrier.

The AS should cyclically scan the BCCH(D) of the surrounding en-route, intermediate and airport stations indicated by the primary frequencies. The BCCH(D) data should be stored in a table for use in the GS selection decision according to the algorithms defined in subclause 8.10.6.3.

NOTE: Although at this stage actual range to the GSs are not known, relative range is available. Thus cell selection prior to acquisition on network time has to be based on nearest range. If, in special network configurations, this leads to access attempts to a cell out of range, the AS should close down the communication immediately after the initial access (refer to subclause 8.10.4), select a new GS based on the now acquired network time and repeat the initial exchange.

#### **8.10.6.3 GS selection**

The AS shall identify whether it is to communicate with an en route, intermediate or airport GS. When no cell selection is possible then all AS transmissions shall be terminated.

The following rules shall apply at all times for both initial cell selection and handover:

- 1) if Weight on Wheels (WOW) is true then selection priority is assigned to GS types as AP first, INT second and ER last;

If WOW is not true then selection priority is assigned to GS types as ER first then INT.

Transmissions to an AP GS shall cease within 10 seconds of WOW becoming not true.

- 2) an unsynchronised GS shall have lowest priority for cell selection;
- 3) handover to an unsynchronised GS shall not be allowed;
- 4) an AS shall not select or continue to use an ER or INT GS if the range to that GS is greater than MAXimum RaNGe (MAXRNG);
- 5) an AS shall not select or continue to use an ER or INT GS if the aircraft altitude is greater than the MAXALT. If altitude information is not available then the AS shall only use an ER or INT GS if its MAXimum ALTitude (MAXALT) is greater than or equal to 40 000 feet.

As a design aim the Highest Closing Rate (HCR) and BER quality (Q) may be used when selecting a GS where more than one GS of the required type is available.

A second design aim should be to minimise the number of handovers without jeopardising the transmission quality.

#### **8.10.6.4 Synchronisation**

The exchanges to be implemented for this purpose are detailed in subclauses 8.5.2, 8.10.10 and 8.11. A DCCH shall be set up between the AS and GS when synchronisation is complete.

#### **8.10.6.5 Negotiation**

The AS shall request a service and shall be offered a set of suitable slots by the GS. Details of the implementation of the selection procedure carried out by the GS is outside the scope of this ETS.

#### **8.10.7 Network pre-requisites**

##### **8.10.7.1 BCCH**

The BCCH is a unidirectional channel transmitted by all GS in selection of the correct radio cell and access into the system. The BCCH shall be divided into two logical channels, BCCH(S) and BCCH(D).

##### **8.10.7.1.1 BCCH(S)**

BCCH(S) shall be transmitted on all carriers on slot 16 on the TDM frame. It shall contain the data structure for the AS to synchronise to the transmissions on the carrier. In addition it shall communicate in a data field the number of the access carriers offered by the GS, the GS synchronisation status, the slot allocations for the negotiation channel, and the BCCH(D). See subclause 8.6 for the slot allocations for the BCCH(S) and the coding of the information.

##### **8.10.7.1.2 BCCH(D)**

BCCH(D) shall be transmitted on the access carrier in the TDM slot indicated by the BCCH(S). If no access carrier can be offered, the BCCH(D) shall not be transmitted (see subclause 8.10.10).

The BCCH(D) shall contain data that describes the GS and the corresponding cell limits. In addition it shall offer an opportunity to transmit PAGE, ENGPAGE and SHUTDOWN requests.

##### **8.10.7.2 GS Handover**

The GS shall accept a handover request from an aircraft in its cell area when it has adequate free capacity.

#### **8.10.8 Radio Link Measurements (RLM)**

RLM shall be used in the decision process for radio link management, e.g. for handover control and RF power control.

##### **8.10.8.1 Signal strength**

The method of measuring signal strength at the AS and GS is outside the scope of this ETS.

##### **8.10.8.2 Signal quality**

The received signal quality shall be measured on all transmissions within the receiver in a manner which can be related to an equivalent average BER, before any error correction is performed, as defined in this subclause.

#### 8.10.8.2.1 AS

Using the information collected for each frame, an average BER in the radio channel shall be calculated over a period of 64 frames.

#### 8.10.8.2.2 GS

Using the information collected for each frame, an average BER for each link in the radio channel shall be calculated over a period of 64 frames.

#### 8.10.8.2.3 Range of parameter

A parameter Q is defined which shall have values as shown in table 15.

Table 15: Q values

Q	BER	P
1	$BER > 10^{-2}$	0,90
2	$10^{-2} > BER > 10^{-3}$	0,70
3	$10^{-3} > BER > 10^{-4}$	0,70
4	$BER < 10^{-4}$	0,70

The probability P of the current BER, measured under test conditions on all data and traffic bits, being assigned to the correct value of Q shall be better than the values listed above when measured over a pseudo-random bit stream of at least  $10^6$  bits in length.

#### 8.10.8.3 Absolute distance (AS only)

When the AS has acquired network time, the absolute distance to the station in use shall be indicated by the delay of the received signal relative to network time (see to subclause 8.11). The absolute distance of other GSs may be available from the scanning receiver. The measurements may be stored and used in the processing of handover decisions.

##### 8.10.8.3.1 Range of parameter

Distance shall be measured to a tolerance of 4 km over the range 5 to 400 km.

#### 8.10.8.4 Radio Link Failure (RLF)

The criterion for determination of RLF is based on the success rate of decoding messages on each DCCH in each direction. A RLF shall be declared if less than 75% of the DCCH layer 2 frames are decoded successfully over a period of 15 seconds. Refer to subclause 9.6.5.7.7 for the primitive definition.

#### 8.10.9 Timing control

The synchronisation of the AS shall be achieved through the procedure defined in subclause 8.11. The format of the timing control message is defined in subclause 8.6.2.1.1.

#### 8.10.10 Control parameters

There are two types of control parameters defined within this ETS:

- those transmitted cyclically on the BCCH; and
- those transmitted as required at intervals of not less than 9 seconds on the RCCH.

### 8.10.10.1 Definition of network parameters

The parameters applicable to the network category are:

1) Network TIME (TIM)

This parameter shall include the current year (offset from a base year, with a range of 0 to 31 years), date, and current network time (hours and minutes only) based on Universal Time Constant (UTC).

2) Ground Station POSition (GSPOS)

The GSPOS shall include a definition of the location of the GS in latitude and longitude to a resolution and accuracy of 6 arc min.

3) Ground Station Identity Code (GSIC)

The GSIC is a unique code that shall identify each GS, Cell Type, and Equipment part in the GS networks (refer also to ETS 300 326-1, [12] clause 8).

4) LIMit (LIM)

LIM represents the radius of the ER GS cell boundary for an AS at 30 kft altitude, and the radius of the INTGS and APGS independent of altitude. LIM shall be in the range 0 to 400 km in increments of 4 km.

5) Limit K (LIMK)

LIMK represents a margin inside the cell boundary that warns an AS that a handover is imminent. The margin shall be a distance constant (in km) for a given GS. Its value is normally 30 km, but provision shall be made through this parameter to allow the network implementer to modify the value to improve the service. The parameter shall have a range of 0 to 63 km and a resolution of 4 km or better.

6) LIMit ALTitude (LIMALT)

LIMALT allows the cell boundary to be controlled as a function of altitude. The use of this parameter is defined in subclause 8.10.10.4, and should have a range of 0 to 7 m/ft. The resolution shall be 0,5 m/ft.

7) MAXimum ALTitude (MAXALT)

The efficient use of GSs is dependent on the frequency re-use distance. This parameter shall allow the network operator to define the maximum altitude at which a GS may be used, therefore controlling co-channel interference and station separation. MAXALT should have a range of 0 to > 43 000 ft. The resolution will vary.

An aircraft, not equipped with a measure of altitude in the form required by an AS, may provide an inferior metric for this parameter. This may result in a reduced service to its customers. A definition of the procedure to be used in these circumstances is given in subclause 8.10.6.3.

8) QUality INTermediate (QUINT)

QUINT defines the maximum allowable signal quality to be received from any ERGS whilst operating with an INTGS.

If an AS, without altitude measurement, can receive a QUINT parameter from any ERGS at a higher signal quality level than an INTGS, then the AS shall use the ERGS with the higher signal quality level. QUINT shall have the range 1 to 4.

9) En-Route PRImary FREQuency (ERPRIFREQ)

ERPRIFREQ is a list identifying the frequencies that collectively give the AS the information that it needs about all the ER GSs with which it is permitted to communicate. The list may have a length of up to 12.

10) PRImary FREQuency (PRIFREQ)

PRIFREQ is a list identifying the frequencies that collectively give the AS all the information that it needs about all the INTGSs and APGSs with which it can legally communicate. For all the currently determined system configurations, the list should not exceed six entries in length.

**8.10.10.2 Definition of Radio Resource (RR) parameters**

BCCH(S) parameters in this category are:

- frame number;
- BCCH(D) slot number;
- negotiation slot number;
- access carrier;
- GS synchronisation status.

For initial access to the system each GS shall offer one access carrier to all ASs. This access carrier shall be established by the system to minimise the need for handovers by newly established calls and optimise the traffic distribution on that carrier on the GS. To achieve this the access carrier shall be selected as the optimum carrier for a new AS according to the traffic balancing rules given in ETS 300 326-3 [11]. The radio channel number of the access carrier shall be transmitted with the BCCH(S) on all carriers used by the GS. The BCCH(D) shall always be transmitted on the access carrier. The slot for the BCCH(D) and negotiation channel, along with the GS synchronisation status shall be indicated in the BCCH(S) of the access channel.

If the traffic load at a GS changes, the GS shall check the selection of the access carrier according to the requirements given above and update the value transmitted with the BCCH(S).

BCCH(D) parameters in this category are:

- Power Ground Station (PGS):

PGS allows the AS to determine the initial transmit power for call initiation as defined in subclause 8.10.4. PGS should have the range + 49 dBm to + 19 dBm and shall have a resolution of 2 dB (i.e. 16 levels).

- Receiver MINimum acceptable signal level (RMIN):

RMIN allows a GS to define the minimum signal level acceptable at its antenna. This shall be used to set the initial transmit e.i.r.p for call initiation as defined in subclause 8.10.4. The parameter is in dB relative to static sensitivity and shall have a range of 0 to 15 dB and have a resolution of 1 dB.

**8.10.10.3 Definition of other parameters**

BCCH(D) parameters in this category are:

- 1) SHUTDOWN

This parameter allows a network operator to force an AS to shutdown immediately even if the AS in question is not transmitting at the time. The parameter shall include the identity of the aircraft being shutdown, and the shutdown duration.



2) PAGE

This allows the network operator to provide a paging service through the broadcast of a short message. The BCCH(D) message shall only contain the identity of the AS being paged. The AT shall then initiate a DCCH connection and through a dialogue, collect the additional information which may include the following:

- pager's ID;
- pagee's ID;
- number to call;
- fixed message (option);
- free message (option).

3) ENGPAGE

This allows technical personnel to access an AS through a management or service centre. The message on the BCCH(D) shall identify an AS uniquely. The AS shall initiate a DCCH connection to a GS and shall collect the information that shall allow it to establish its part of the connection between the paged equipment and the required GS through a Network Management Centre ( NMC).

RCCH parameters within this category are:

PoWeR ConTroL level adjustment (PWRCTL);

This parameter shall command an absolute power level from the AS transmitter.

Transmitter TIMe ConTroL (TIMCTL);

This parameter shall command the advance or retard of an AS transmitter timing.

**8.10.10.4 Calculation of range limit**

Three parameters are applicable to the calculation of range limit for an ER GS:

LIM;

LIMALT;

LIMK.

The maximum range at which AS transmission, in kms, is allowed to an ERGS shall be calculated from the formula:

$MAXRNG = LIM - (LIMALT \times (ALT - 30\ 000) / 1\ 000)$  for  $ALT > 30\ 000$  feet.

$MAXRNG = LIM$  for  $ALT < 30\ 000$  feet.

where:

MAXRNG is the maximum range, in kms, of the current GS for the current AS altitude in feet given by ALT; and

HORNG = MAXRNG - LIMK;

where:

HORNG defines the handover range in kms.

NOTE: ALT = 40 000 ft if the AS is not equipped with ALT measurement.

## **8.11 Radio sub-system synchronisation**

### **8.11.1 Introduction**

This subclause details the requirements for the synchronisation and tracking of TDMA timing.

The TDM signals shall be synchronised using an external timing reference, to produce the Network Clock (NC). This shall allow an AS to synchronise to one GS, establish the range to this GS, and any other GS in range.

To access the TDMA network the AS shall acquire a representation of the NC to ensure that its transmissions arrive correctly within the allocated slot position at the GS. In acquiring the timing of any one GS the AS shall acquire the NC.

A non-transmitting AS shall acquire a representation of the NC by using the Cold Start Synchronisation (CSS) procedure, after which, during duplex operation, the AS shall track the Network Clock. Under certain circumstances Warm Start Synchronisation (WSS) will enable the AS to place a transmitted slot directly in synchronism with the GS timing.

### **8.11.2 GS synchronisation**

The synchronising method shall be designed such that periodical adjustment will not be required.

The synchronisation of all the GS transmissions produce reference timing which shall be referred to as the NC, and shall delineate the start of the GS transmit frame.

The super-frame start time shall be within 2  $\mu$ s of the start of zero seconds in each even minute in each hour of UTC. This coincidence shall occur every 75 super-frames.

NOTE: Slot types used throughout this document are defined in subclause 8.6.

### **8.11.3 Cold Start Synchronisation (CSS)**

#### **8.11.3.1 AS cold start requirements**

##### **8.11.3.1.1 GS acquisition**

The AS shall use the received S1 slot transmitted from the GS to acquire an initial representation of the NC, referenced to the beginning of the S1 slot to a resolution of  $\pm T_b/4$  or better (where  $T_b$  represents a bit period).

##### **8.11.3.1.2 Transmitted S2 slot**

An AS making first contact with a GS has no means of deducing the time to transmit to ensure arrival of the signals at the GS at the correct time. An AS, in order to synchronise to the GS Network Clock, shall transmit a S2 Slot in line with the initial representation of the NC acquired in subclause 8.11.3.1.1.

##### **8.11.3.1.3 Received G3 slot**

After transmitting an S2 slot to the GS, the AS shall decode any G3 slot received in the negotiation slot as an RCCH transmission from the GS.

The AS shall decode the timing correction and temporary aircraft identity by decoding as detailed in subclause 8.6.2.1.1.

#### **8.11.3.1.4 Timing adjustment**

The AS shall retard its representation of the NC (and thus the transmitted timing) in increments of  $T_b/4$ , using the timing correction value received in the G3 slot transmission (IRCCH).

Throughout normal transmission, timing shall be maintained using the timing message on the RCCH.

#### **8.11.3.2 GS cold start requirements**

##### **8.11.3.2.1 S2 reception**

The GS shall be capable of measuring the arrival time of an S2 slot from the beginning of the receive frame to the beginning of the S2 slot reception, with a resolution of  $\pm T_b/4$  or better.

#### **8.11.4 Tracking procedure**

##### **8.11.4.1 AS requirements**

The AS shall measure the delay to a resolution of  $\pm T_b/4$  or better between the acquired representation of the NC and reception of any slot from the GS.

Slots shall be transmitted by the AS earlier than the NC by an amount equal to the delay measured on the receive signal relative to the NC.

NOTE: This approach enables the AS transmit clock to be automatically adjusted to ensure that the receive and transmit clocks are equidistant from the acquired NC, therefore allowing the AS to adjust its timing for radial changes of velocity and distance without timing adjustments from the GS.

##### **8.11.4.2 GS requirements**

The GS shall measure the arrival time of all slot types from an AS to a resolution of  $\pm T_b/4$  or better. If the arrival timing error of any AS slot reaches  $\pm T_b/2$  the GS shall request a timing adjustment by the AS. The period between requests for AS timing adjustments by the GS shall not be less than 9 seconds.

The timing adjustment shall be accomplished by the use of an error correction transported by the channel described in subclause 8.6.

#### **8.11.5 Warm Start Synchronisation (WSS)**

##### **8.11.5.1 GS**

The GS shall acquire a S2 slot in any of the sixteen time-slots that may be free, and measure the timing error to a resolution of  $\pm T_b/4$  or better.

##### **8.11.5.2 AS**

WSS shall be used by an AS that can transmit directly into the requested/negotiated window of the required time-slot within  $\pm T_b/2$ .

## 9 TFTS radio interface layer 2

### 9.1 General

This subclause describes the Link Access Protocols on the Da channel (LAPDa).

The purpose of LAPDa is to convey information between layer 3 entities across the radio interface (AS - GS interface) using the Da channel.

NOTE: The term Da channel is used for convenience to designate the collection of all the various signalling channels required in the system. Refer also to clause 7.

The definition of LAPDa is based on the principles and terminology of:

- CCITT Recommendations X.200 [3] and X.210 [4], the reference model for Open Systems Interconnection (OSI);
- CCITT Recommendations Q.920 [13] and Q.921 [14], the specification of LAPD for the user network interface to ISDN;
- GSM Technical Specification 04.05 [15] MS-BSS Data Link Layer, general aspects and GSM Technical Specification 04.06 [16] MS-BSS Data Link Layer Specification.

LAPDa is independent of transmission bit rate. It requires physical channels with characteristics as defined in clause 8.

### 9.2 Layer 2 services

The services provided by layer 2 are the combination of the services and functions provided by both the layer 2 and layer 1.

A layer 2 SAP is the point at which the layer 2 provides services to layer 3. The SAP is identified by a Service Access Point Identifier (SAPI). Associated with each layer 2 SAP is one or more layer 2 connection end-point (see figure 26). A layer 2 connection end-point is identified by a layer 2 Data Link Connection Identifier (DLCI) as seen from the layer 2.

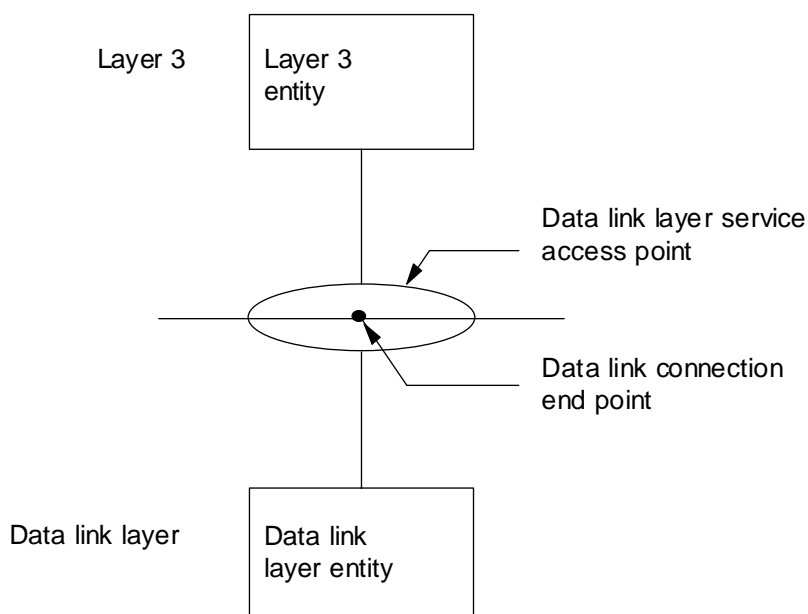
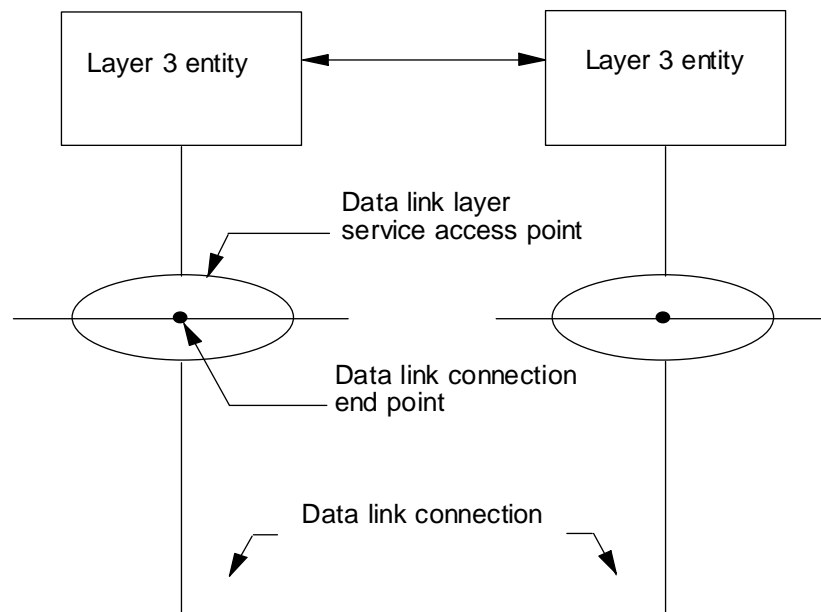


Figure 26: Entities, service access points and end-points

Co-operation between layer 2 entities is governed by a peer-to-peer protocol specific to the layer. In order for information to be exchanged between two or more layer 3 entities, association is established between the layer 3 entities in the layer 2 using a layer 2 protocol. This association is called a layer 2 connection. Layer 2 connections are provided by the layer 2 between two or more SAPs (see figure 27).



**Figure 27: Peer-to-peer relationship**

Layer 2 message units are conveyed between layer 2 entities by means of physical connection.

Layer 3 requests services from the layer 2 via service primitives. The same applies for the interaction between the layer 2 and physical layer. The primitives represent, in an abstract way, the logical exchange of information and control between the layer 2 and adjacent layers. They do not specify or constrain implementation.

The primitives that are exchanged between the layer 2 and adjacent layers are of the following four types (see also figure 28):

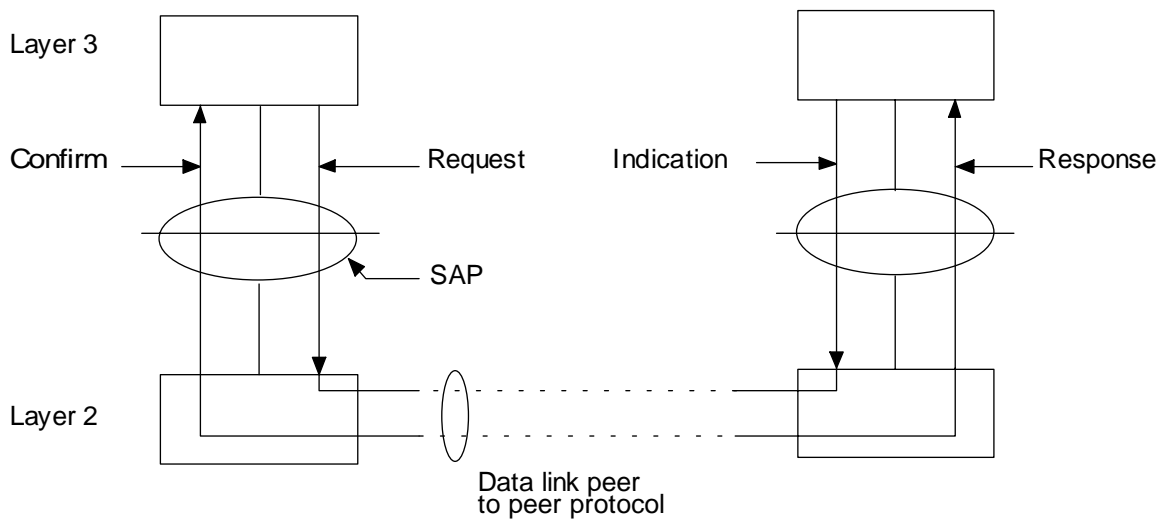
- REQUEST;
- INDICATION;
- RESPONSE;
- CONFIRM.

The REQUEST primitive type is used when a higher layer is requesting a service from the next lower layer.

The INDICATION primitive type is used by a layer providing service to notify the next higher layer of any specific activity which is service related. The INDICATION primitive may be the result of an activity of a lower layer related to the primitive type REQUEST at the peer entity.

The RESPONSE primitive type is used by a layer, if the receipt of the primitive type INDICATION from a lower layer is to be acknowledged, to acknowledge receipt, from a lower layer, of the primitive type INDICATION.

The CONFIRM primitive type is used by the layer providing the requested service to confirm that the activity has been completed.



NOTE: The same principle applies for layer 2 to layer 1 interactions.

**Figure 28: Primitive action sequence**

Layer-to-layer interactions are specified in subclause 9.6.

Information is transferred, in various types of message units between peer entities and between entities in adjacent layers that are attached to a specific SAP. The message units are of two types:

- message units of a peer-to-peer protocol; and
- message units that contain layer-to-layer information concerning status and specialised service requests.

The message units of the layer 3 peer-to-peer protocol are carried by the layer 2 connection. The message units containing layer-to-layer information concerning status and specialised service requests are never conveyed over a layer 2 or a physical connection.

The following subclauses describe in general terms (see also figure 29):

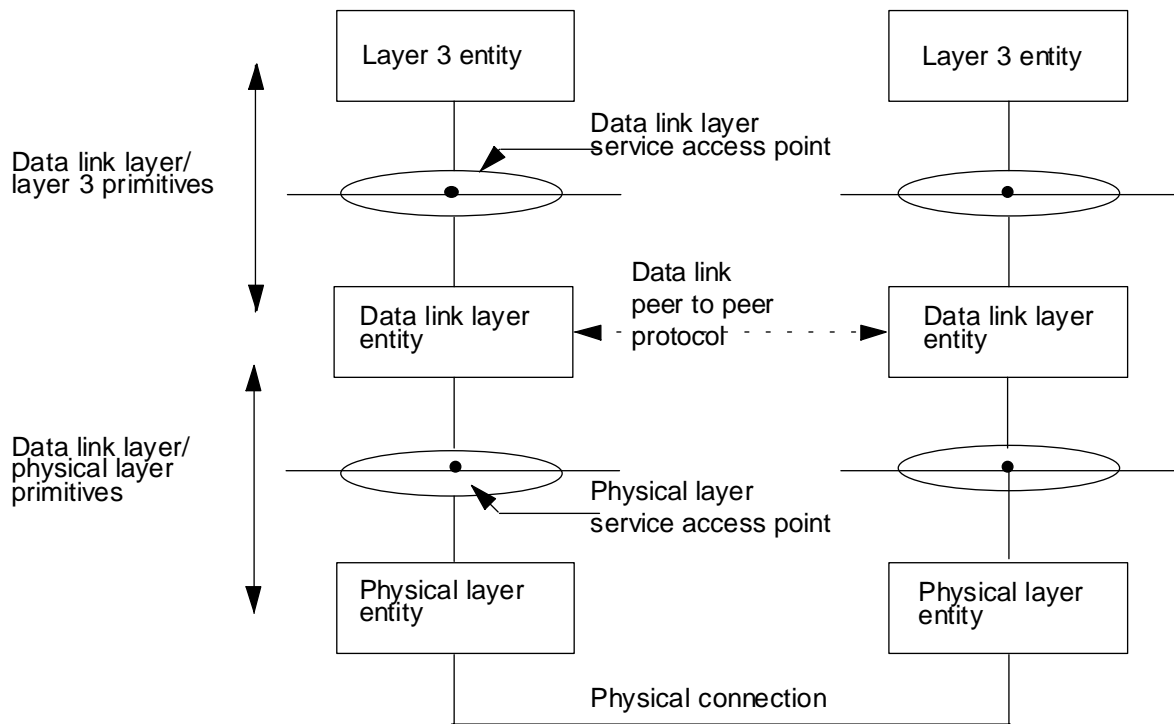
- the peer-to-peer protocol for the transfer of information and control between any pair of layer 2 service access points;
- the interactions between the layer 2 and layer 3, and between the layer 2 and the physical layer.

### **9.3 Overview description of LAPDa functions and procedures**

#### **9.3.1 General**

The purpose of LAPDa is to convey information between layer 3 entities across the TFTS radio interface using the Da channel. Specifically LAPDa will support:

- multiple layer 3 entities;
- multiple physical layer entities;
- BCCH signalling;
- DCCH signalling.



**Figure 29: Layer 2 reference model**

The frame structure of the layer 2 messages is defined in subclause 9.6.

LAPDa includes functions for:

- the provision of one or more layer 2 connections on a Da channel. Discrimination between the layer 2 connections is by means of layer 2 DLCIs;
- segmentation and subsequent re-assembly of layer 3 message units;
- sequence control, to maintain the sequential order of frames across a layer 2 connection;
- detection of transmission, format and operational errors on a layer 2;
- recovery from detected transmission, format, and operational errors. Notification to the management entity of unrecoverable errors; and
- flow control.

Two types of operation of the layer 2 are defined for layer 3 information transfer, unacknowledged operation and multiple frame operation (acknowledged mode). They may co-exist on a Da channel.

The BCCH will only support unacknowledged operation while the DCCH will also support acknowledged operation.

### 9.3.2 Unacknowledged operation

With this type of operation layer 3 information is transmitted in Unnumbered Information (UI) frames.

At the layer 2 the UI frames are not acknowledged. Flow control mechanisms and error recovery mechanisms are not defined.

### 9.3.3 Acknowledged operation

With this type of operation, layer 3 information is transmitted in frames that are acknowledged at the layer 2.

Error recovery procedures based on re-transmission of acknowledged frames are specified. In the case of errors which cannot be corrected by the layer 2, a report to the radio resources management entity is made. Flow control procedures are also defined.

Acknowledged operation is applicable for DCCHs.

Only one form of acknowledged information transfer is defined, ie multiple frame operation.

For multiple frame operation, layer 3 information is sent in numbered Information (I) frames. A number of I frames may be outstanding at the same time. Multiple frame operation is initiated by a multiple frame establishment procedure using a Set Asynchronous Balanced Mode (SABM) command.

### 9.3.4 Information transfer mode

#### 9.3.4.1 Information transfer on the BCCH

The BCCH exists only in the GS to AS direction and is used for broadcasting radio sub-system information to ASs. Only UI frames are sent on the BCCH.

#### 9.3.4.2 Information transfer on the DCCHs

On the DCCHs both unacknowledged operation and multiple frame operation are possible. The type of operation is determined by layer 3.

### 9.3.5 Release of layer 2

Multiple frame operation may be released in two ways:

- normal release, i.e. by exchange of commands/response. Normal release is initiated by layer 3.
- abnormal release, i.e. without exchange of commands/responses. In this case the release operation is independent at the two ends of the link. Abnormal release is commanded by the radio resources management entity.

The release mode is indicated by the radio resources management entity.

No release mechanism using exchange of commands/responses is defined for unacknowledged operation.

### 9.3.6 Identification of layer 2 end points

The layer 2 Connection Identifier (DLCI) consists of two elements:

- the SAPI which is carried in the address field of each frame;
- the identification of the logical channel of layer 1 on which the layer 2 connection is or is to be established. This information is not carried in frames between layer 2 peer entities but is managed locally in each end system and is carried in primitives between the layers.

When a layer 3 message unit is to be sent, layer 3 will select the appropriate SAP and layer 2 connection end point. Layer 3 will indicate to the layer 2 which layer 2 connection end point has been chosen.

When receiving a frame containing a layer 3 message unit the layer 2 will receive from the physical layer an indication concerning the type of channel on which the frame was received. This information together with the SAPI contained in the frame enables the layer 2 to deliver the layer 3 message unit to the required layer 2 connection end point of the indicated SAP.



The SAPI takes a specific value for each of the following functions carried on the Da channel:

- call control signalling, RRM signalling and maintenance information as defined in clause 10; SAPI = 0

Other functions requiring SAPI values may be defined in the future.

## **9.4 Service characteristics and requirements**

### **9.4.1 General requirements**

The layer 2 shall provide services to layer 3 and utilises the services provided by the physical layer.

In this subclause and clause 10 the following general syntax is used for describing primitives:

XX - Generic Name - Type: Parameters

where:

XX designates the layer providing the services. In this ETS XX is DL for the layer 2, PH for the physical layer or MDL for the RRM entity to the layer 2 interface.

### **9.4.2 Services provided to layer 3**

#### **9.4.2.1 General**

The specifications in this ETS of the interactions with layer 3 (primitives) provides a description of the services that the layer 2, plus the physical layer, offer to layer 3 as viewed from layer 3.

Two forms of information transfer services shall be associated with layer 3. The first shall be based on unacknowledged information transfer at the layer 2 and the second service shall be based on acknowledged information transfer at the layer 2 using multiple frame operation. Different information transfer services may coexist on the same layer 2 subject to restrictions imposed by the type of physical channel being used.

#### **9.4.2.2 Priority**

The priority between layer 2s shall be in accordance with the SAPI value of 0 indicating highest priority.

NOTE: Messages with this indication are sent in accordance with their SAPI (see subclause 9.5 below for definition of SAPI) using normal first-in first-out principles for messages on the same SAPI.

#### **9.4.2.3 Segmentation**

For the acknowledged mode of information transfer the layer 2 shall offer segmentation at the transmitter of layer 3 message units if the message unit is longer than the information of the layer 2 frames. At the receiver the segmented layer 3 message units shall be concatenated such that the integrity of the layer 3 message unit shall be restored.

For unacknowledged operation the layer 2 shall not offer segmentation services.

NOTE: In this case the information transfer is not acknowledged at the layer 2. Acknowledgement procedures may be provided at higher layers.

#### **9.4.2.4 Unacknowledged information transfer service**

The characteristics of the unacknowledged information transfer service are summarised in the following:

- a) provision of a layer 2 connection between layer 3 entities for unacknowledged information transfer of layer 3 message units;

- b) identification of layer 2 connection end points to permit a layer 3 entity to identify another layer 3 entity;
- c) sending of frames in accordance with priority given to the message;
- d) no verification of message arrival within the layer 2.

The primitives associated with the unacknowledged information transfer service shall be:

- the DL-UNIT-DATA-REQUEST primitive shall be used to request that a message unit be sent using the procedures for unacknowledged information transfer service;
- the DL-UNIT-DATA-INDICATION primitive shall indicate the arrival of a message unit received by means of unacknowledged information transfer;
- the parameter associated with both these primitives shall be the message unit.

#### 9.4.2.5 Acknowledged information transfer service

One mode of operation is defined, i.e. multiple frame operation.

The characteristics of this service are summarised in the following:

- provision of a layer 2 connection between layer 3 entities for acknowledged information transfer of layer 3 message units;
- identification of layer 2 connection end points to permit a layer 3 entity to identify another layer 3 entity;
- sequence integrity of layer 2 message units in the absence of machine malfunctions;
- notification to the peer entity in the case of machine errors, for example, loss of sequence;
- notification to the radio resources management entity of unrecoverable errors detected by the layer 2;
- flow control;
- sending of frames in accordance with the SAPI value;
- segmentation and re-assembly control functions.

The primitives associated with the multiple frame acknowledged information transfer services shall be:

- 1) Data transfer using I frames:

DL-DATA-REQUEST/INDICATION

The DL-DATA-REQUEST primitive shall be used to request that a message unit be sent using the procedures for multi-frame acknowledged information transfer. The DL-DATA-INDICATION primitive shall indicate the arrival of a message unit received by means of acknowledged information transfer. The parameter associated with these primitives shall be the message unit.

- 2) Establishment of multiple frame operation using the SABM command:

DL-ESTABLISH-REQUEST/INDICATION/CONFIRM

These primitives shall be used to request, indicate and confirm the establishment of multiple frame operation between two layer 2 entities. Possible parameters are the message unit and the establishment mode - normal or contention resolution.

- 3) Termination of multiple frame operation using the DISC command:

DL-RELEASE-REQUEST/INDICATION/CONFIRM

These primitives shall be used to request, indicate and confirm an attempt to terminate multiple frame operation between two layer 2 entities. The parameter associated with this primitive shall be the release mode - normal or local end release.

- 4) Suspension of multiple frame operation:

DL-SUSPEND-REQUEST/INDICATION/CONFIRM

These primitives shall be used in an AS to request, indicate and confirm the suspension of multiple frame operation while changing a dedicated channel.

- 5) Resumption of multiple frame operation:

DL-RESUME-REQUEST/CONFIRM

These primitives shall be used in an AS to request and confirm the resumption of multiple frame operation after it has been suspended.

### 9.4.3 Services required from the physical layer

The services provided by the physical layer are described in detail in subclauses 8.1 to 8.5. They are summarised in the following:

- physical layer connection for transparent transmission of bits. The bits are to be delivered to the peer layer 2 entity in the same order in which they were submitted to the physical layer by the sender;
- indication of the physical status of the Da channel;
- transmission of layer 2 message units according to their respective layer 2 priority;
- provision of synchronisation and transparency mechanisms;
- provision of error protection to ensure a low residual bit error rate at the layer 2;
- provision of T200 timing indication (see subclause 9.6);

The primitives between the layer 2 and layer 1 shall be:

- 1) Data transfer:

PH-DATA-REQUEST/INDICATION

These primitives shall be used to request that a message unit be sent and to indicate the arrival of a message unit. Parameters associated with these primitives shall be the layer 2 message unit, the priority and the type of channel being used.

- 2) Data reception opportunity:

PH-G2-INDICATION

This primitive shall be used to indicate that an opportunity to receive a G2 type slot has occurred. This indication shall be given to the layer 2 regardless of whether or not a G2 slot is successfully decoded. This primitive shall also set the value of timer T200. There shall not be any parameters associated with this primitive.

#### **9.4.4 Administrative services**

##### **9.4.4.1 General description of administrative services**

Administrative services shall be supported by the RRM entity in both ASs and GSs.

The RRM entity shall support several internal functions of the AS or the GS not requiring layer 3 peer-to-peer information transfer. The functions to be provided for the layer 2 shall be:

- error reporting between the layer 2 and the radio resources management entity;
- abnormal release of the layer 2 in case of protocol or other failures from which the layer 2 cannot recover on its own.

The administrative functions and the interactions between the RRM entity and the layer 2 entities are described in terms of service primitives.

##### **9.4.4.2 Definition of primitives for administrative services**

The primitives between the RRM entity and the layer 2 shall be:

- 1) Error handling

MDL-ERROR-INDICATION

The primitive shall be used by the layer 2 to indicate that there is an error in the layer 2 procedures that cannot be resolved by normal exception handling procedures. Parameters associated with this primitive shall be the error report and the type of channel.

- 2) Release

MDL-RELEASE-REQUEST

This primitive shall be used by the RRM entity to initiate local end release of a layer 2. Parameters associated with this primitive shall be the layer 2s to be released.

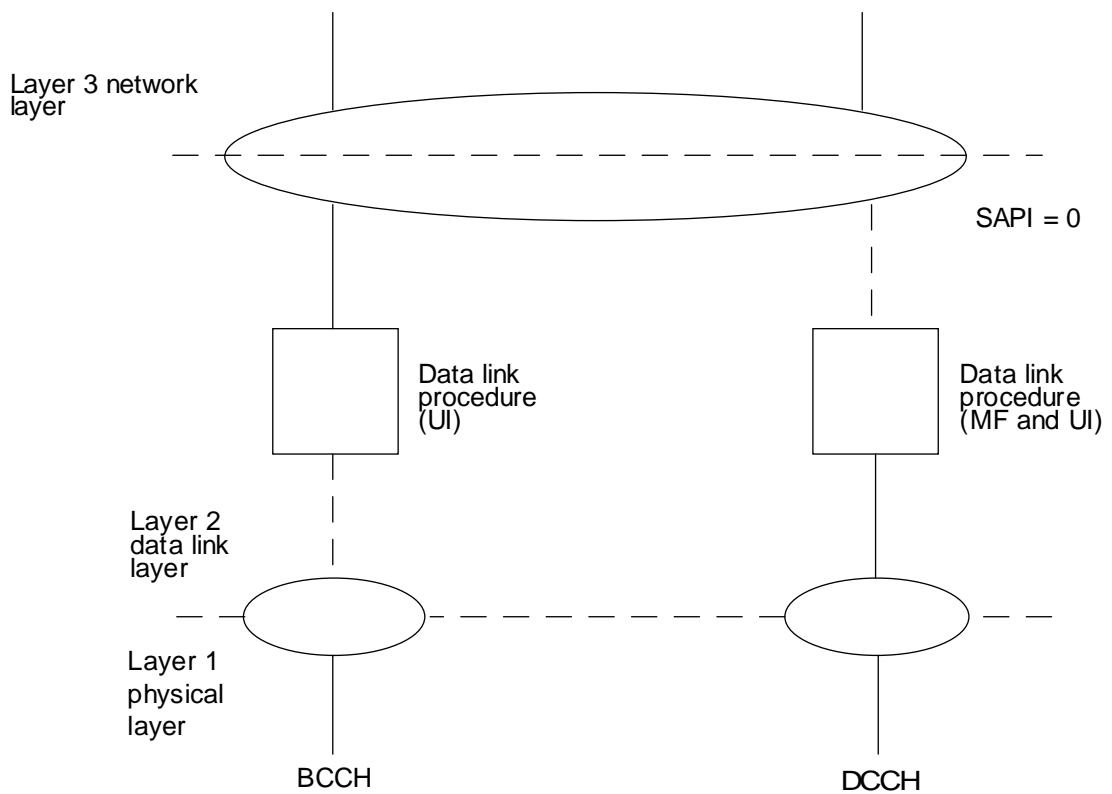
#### **9.5 Overview of Layer 2 structure**

##### **9.5.1 Functional composition**

Figure 30 is an example of a functional block diagram of the layer 2 in the AS. All data link connections terminate at the SAP identified by SAPI = 0. (SAP identifiers SAPI = 1, 2, 3 are reserved for future use).

The GS shall contain a similar arrangement, with one DCCH for each active AS.

Figure 30 also illustrates two procedural types, the layer 2 procedure, and the broadcast control channel procedure.



**Figure 30: Example of the layer 2 configuration in the AS**

### 9.5.2 Layer 2 procedure

There shall be one instance of the layer 2 procedure for each SAPI on each physical channel supported on that SAPI.

For some combinations of SAPI and physical channel only a subset (e.g. unacknowledged operation) of the overall layer 2 procedure shall be required.

The procedure shall analyse the control field and the length indicator field of the received frame and shall provide appropriate peer-to-peer responses and layer-to-layer indications. In addition, it shall analyse the layer 2 service primitives and shall transmit the appropriate peer-to-peer commands and responses.

The procedure shall also perform segmentation and re-assembly of layer 3 message units.

## 9.6 Layer 2 specification

### 9.6.1 General

This subclause defines the frame structures, elements of procedure, and format of fields for the proper operation of the LAPDa.

The frame formats defined for LAPDa shall be based on those defined in GSM Technical Specification 04.06 [16] for LAPDm.

The LAPDa shall support two modes of operation:

- unacknowledged operation using UI frames;
- acknowledged operation using the multiple frame procedure.

The acknowledged mode of operation shall be used at all times on duplex channels (all DCCHs) while the unacknowledged mode shall be used on the BCCH simplex channels.

The LAPDa shall be used on all control (Da) channels unless specified otherwise in this ETS.

## 9.6.2 Frame structure for peer-to-peer communication

### 9.6.2.1 General

The error statistics derived from detailed analysis of data transmissions over a radio path dictate that a short fixed length frame is more suitable than variable length frames.

### 9.6.2.2 Frame format

All LAPDa peer-to-peer exchanges shall be in frames conforming to one of the formats shown in figures 31 and 32.

NOTE: The information and fill fields may have zero lengths, as determined by the value in the length sub-field of the header field, (see subclause 9.6.2.4). The relationship between the frame size, N202, and other parameters is described in subclause 9.6.5.8.

Header field	Octet 1 to 2
Information field	3 to n
Fill field	n+1 to N202-2
FCS field	N202-1 to N202

Figure 31: Frame format, general

Information field	Octet 1 to N202 - 2
FCS field	N202 - 1 to N202

Figure 32: Frame format, BCCH(D)

### 9.6.2.3 Frame delimitation

Frame delimitation shall be provided by the physical layer, which accepts and delivers fixed sized message units. The message unit shall be N202 octets long.

### 9.6.2.4 Header field

The header field, when included, shall consist of two octets. The format of the header field is defined in subclause 9.6.3.2.

NOTE: In the case of frames delivered from layer 1 in the BCCH(D) channel the header information is implied, or redundant, and the header field is therefore omitted.

### 9.6.2.5 Information field

The information field shall contain zero to N201 octets, as determined by the length sub-field of the header field. N201 is defined in subclause 9.6.5.8.

Figure 32 indicates that the information field of a BCCH(D) frame shall always be a fixed length of N202-2 octets.

### 9.6.2.6 Fill field

Octets following the information field and preceding the Frame Check Sequence (FCS) field shall contain the fill pattern of eight bits set to 1.

**9.6.2.7 Frame Check Sequence**

The FCS field shall be a 16 bit sequence. It shall contain the ones complement of the modulo 2 sum of:

a) the remainder of:

$x^k(x^{15}+x^{14}+x^{13}+x^{12}+x^{11}+x^{10}+x^9+x^8+x^7+x^6+x^5+x^4+x^3+x^2+x+1)$  divided (modulo 2) by the generator polynomial, where k is the number of bits in the frame, excluding the FCS field  $((N202-2)*8)$ ; and

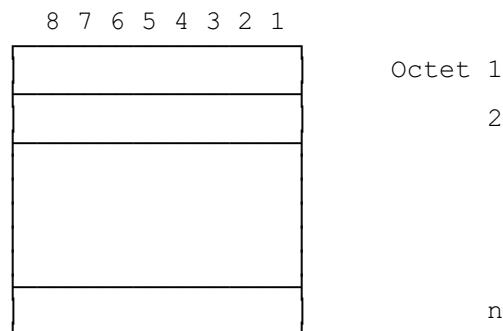
b) the remainder of:

the division (modulo 2) by the generator polynomial  $x^{16}+x^{12}+x^5+1$  of the product of  $x^{16}$  by the polynomial representing the content of the frame. This polynomial is generated using bit 1 of the first octet (DCCH address field or BCCH information field) as the coefficient of the highest order term and bit 8 of the last octet (fill field or information field) as the coefficient of the lowest order term (see format convention in subclause 9.6.2.8).

**9.6.2.8 Format convention**

**9.6.2.8.1 Numbering convention**

The convention used in this ETS is illustrated in figure 33. The bits are grouped into octets. The bits of an octet are shown horizontally and are numbered from 1 to 8. Multiple octets are shown vertically and are numbered from 1 to n.



**Figure 33: Format convention**

**9.6.2.8.2 Mapping to layer 1 message data**

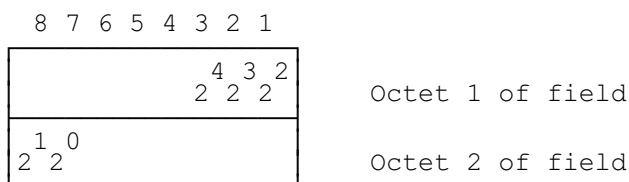
Bit 'b' within octet 'o' in the frame shall be mapped to bit 'b-1' within octet 'o-1' in the G2 data shown in subclause 8.6. The value of each bit shall be preserved.

**9.6.2.8.3 Field mapping convention**

When a field is contained within a single octet, the lowest bit number of the field shall represent the lowest order value.

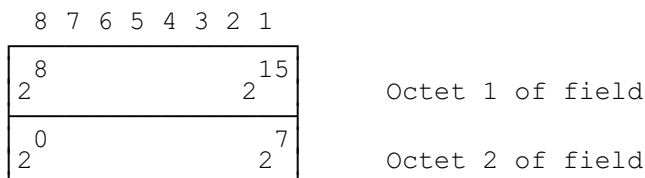
When a field contains more than one octet, the order of bit values within each octet shall progressively decrease as the octet number increases. The lowest bit number associated with a field shall represent the lowest order value.

For example, a bit number can be identified as a couple (o,b) where o is the octet number and b is the relative bit number within the octet. Figure 34 illustrates a field that spans from bit (1,3) to bit (2,7). The high order bit of the field is mapped on bit (1,3) and the low order bit is mapped on bit (2,7).



**Figure 34: Field mapping convention**

An exception to the field mapping convention shown in figure 34 is the data link layer FCS field which shall span two octets. In this case, bit 1 of the first octet shall be the high order bit and bit 8 of the second octet shall be the low order bit. This is illustrated in figure 35.



**Figure 35: FCS mapping convention**

**9.6.2.9 Invalid frames**

A frame shall be invalid if:

- a) it contains a frame check sequence error; or
- b) it contains a service access point identifier (see subclause 9.6.3.3.2) which is not supported by the receiver.

Invalid frames shall be discarded without notification to the sender. No action shall be taken as the result of the received frame.

**9.6.3 Elements of procedure and formats of fields for data-link layer peer-to-peer communication**

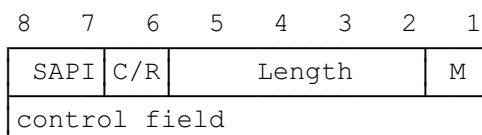
**9.6.3.1 General**

The elements of procedures define the commands and responses that shall be used on the data link connections carried on the Da channel.

Complete procedures shall be derived from these elements of procedures and are described in subclause 9.6.5.

**9.6.3.2 Header field format**

The header field format shown in figure 36 contains the command/response indication bit, the data link layer Service Access Point Identifier (SAPI), the length field, the More (M) bit, and the control field.



**Figure 36: Address field format**



**9.6.3.3 Header field variables**

**9.6.3.3.1 Command/Response field bit (C/R)**

The C/R bit shall identify a frame as either a command or a response. The AS side shall send commands with the C/R bit set to "0", and responses with the C/R bit set to "1". The GS side shall do the opposite; that is, commands are sent with the C/R bit set to "1", and responses are sent with the C/R bit set to "0". The combinations for the GS side and AS side are shown in table 16.

**Table 16: C/R field bit usage**

Command/ response	Direction	C/R Value
Command	GS > AS	1
	AS > GS	0
Response	GS > AS	0
	AS > GS	1

**9.6.3.3.2\_ Service Access Point Identifier**

The SAPI shall identify a point at which data link layer services are provided by a data link layer entity to a layer 3 entity. Consequently, a SAPI shall specify a data link layer entity that shall process a data link layer frame and also a layer 3 entity which shall receive the information carried by the data link layer frame.

The SAPI shall allow 4 service points where bit 7 of the header field octet containing the SAPI shall be the least significant binary digit and bit 8 shall be the most significant. The SAPI values shall be allocated as shown in table 17.

**Table 17: Allocation of SAPI values**

SAPI Value	Related layer 3 entity
0	Air interface signalling (eg call control, RRM)
1 to 3	reserved for future use

**9.6.3.3.3 Length field**

The length field shall be used to indicate the number of octets contained in the information field of UI, SABM, Unnumbered Acknowledgement (UA) or I frames. Its value shall lie in the range 0 to N201 inclusive.

**9.6.3.3.4 More data bit (M)**

The M bit shall be used to indicate segmentation of layer 3 message units on data link layer frames.

Its use within information (I) frames is defined in subclause 9.6.5.2.

In frames other than information frames, the M bit shall be set to "0".

**9.6.3.3.5 Control field**

The control field shall consist of one octet. The format of the control field is defined in subclause 9.6.3.4.

#### 9.6.3.4 Control field formats

The control field shall identify the type of frame, which shall be either a command or a response. The control field shall contain sequence numbers where applicable.

Three types of control field formats are specified: numbered information transfer (I format), supervisory functions (S format), and unnumbered information transfer and control functions (U format). The control field formats for LAPDa shall be as shown in table 18.

**Table 18: Control field format**

Control field bits	8	7	6	5	4	3	2	1
I format	N (R)			P	N (S)			0
S format	N (R)			P/F	S	S	0	1
U format	U	U	U	P/F	U	U	1	1

NOTE: The abbreviations used in this table are explained in this subclause and subclauses 9.6.3.5 and 9.6.3.6.

##### 9.6.3.4.1 Information transfer (I) format

The I format shall be used to perform an information transfer between layer 3 entities. The functions of N(S), N(R) and P (defined in subclause 9.6.3.5) shall be independent. Each I frame shall have an N(S) sequence number, an N(R) sequence number, which may or may not acknowledge additional I frames received by the data link layer entity, and a P bit that may be set to "0" or "1".

##### 9.6.3.4.2 Supervisory (S) format

The S format shall be used to perform data link supervisory control functions. These control functions shall be acknowledge I frames, request re-transmission of I frames, and request a temporary suspension of transmission of I frames. The functions of N(R) and Poll/Final (P/F) shall be independent in that each supervisory frame shall have a N(R) sequence number, which may or may not acknowledge additional I frames received by the data link layer entity, and a P/F bit that may be set to "0" or "1".

##### 9.6.3.4.3 Unnumbered (U) format

The U format shall be used to provide additional data link control functions and unacknowledged information transfer. This format shall not contain sequence numbers. It shall include a P/F bit that may be set to "0" or "1".

#### 9.6.3.5 Control field parameters and associated state variables

##### 9.6.3.5.1 Poll/Final bit

All frames shall contain P/F, the Poll/Final bit. The (P/F) bit shall serve a function in both command frames and response frames. In command frames the P/F bit shall be referred to as the P bit and in response frames the F bit.

The P bit set to "1" shall be used by a data link layer entity to solicit (poll) a response frame from the peer data link layer entity. The F bit set to "1" shall be used by a data link layer entity to indicate the response frame transmitted as a result of a soliciting (poll) command.

The use of the P/F bit is described in subclause 9.6.5.2.

### **9.6.3.5.2 Multiple frame operation, variables and sequence numbers**

#### **9.6.3.5.2.1 Modulus**

All state variables and sequence numbers shall take values only in the range 0 to 7. All arithmetic operations on state variables or sequence numbers shall be performed modulo 8.

#### **9.6.3.5.2.2 Send state variable V(S)**

Each point-to-point data link connection end-point shall have an associated send state variable ( $V(S)$ ) when using I frame commands. The send state variable shall denote the sequence number of the next in-sequence I frame to be transmitted. The send state variable may take the value 0 through 7. The value of the send state variable shall be incremented by 1 with each successive I frame transmission, and shall not exceed  $V(A)$  by more than the maximum number of outstanding I frames  $k$  ( $k$  is defined in subclause 9.6.5.8.6). The value of  $k$  shall be in the range of  $1 \leq k \leq 7$ .

#### **9.6.3.5.2.3 Acknowledge state variable V(A)**

Each point-to-point data link connection end-point shall have an associated acknowledge state variable ( $V(A)$ ) when using I frame commands and supervisory frame commands/responses. The acknowledge state variable identifies the last frame that has been acknowledged by its peer ( $V(A)-1$  equals the  $N(S)$  of the last acknowledged I frame). The acknowledge state variable can take on the value 0 through 7. The value of the acknowledge state variable shall be updated by the valid  $N(R)$  values received from its peer (see subclause 9.6.3.5.2.6). A valid  $N(R)$  value is one that shall be in the range  $V(A) \leq N(R) \leq V(S)$ .

NOTE: Here, and in the remainder of this ETS, these inequalities will be interpreted modulo 8, i.e. in the sense that  $6 < 7 < 0 < 1$  etc.

#### **9.6.3.5.2.4 Send sequence number N(S)**

Only I frames shall contain  $N(S)$ , the send sequence number of transmitted I frames. At the time that an in-sequence I frame is designated for transmission, the value of  $N(S)$  shall be set equal to the value of the send state variable  $V(S)$ .

#### **9.6.3.5.2.5 Receive state variable V(R)**

Each point-to-point data link connection end-point shall have an associated received state variable ( $V(R)$ ) when using I frame commands and supervisory frame commands/responses. The receive state variable shall denote the sequence number of the next in-sequence I frame expected to be received. The receive state variable may take on the value 0 through 7.

The value of the receive state variable shall be incremented by one with the receipt of an error-free in-sequence I frame whose  $N(S)$  equals the received state variable  $V(R)$ .

#### **9.6.3.5.2.6 Receive sequence number N(R)**

All I frames and supervisory frames shall contain  $N(R)$ , the expected send sequence number of the next received I frame. At the time that a frame of the above types is designated for transmission, the value of  $N(R)$  shall be set equal to the current value of the receive state variable  $V(R)$ .  $N(R)$  shall indicate that the data link layer entity transmitting the  $N(R)$  has correctly received all I frames numbered up to and including  $N(R)-1$ .

### **9.6.3.5.3 Unacknowledged operation - variables and parameters**

No variables are defined. One parameter is defined,  $N201$  (see subclause 9.6.5.8.3).

9.6.3.6 Frame types

9.6.3.6.1 Commands and responses

The following commands and responses shall be used by either the AS or the GS data link layer entities and are represented in table 19. Each data link connection shall support the appropriate set of commands and responses for the type of SAP.

For purposes of the LAPDa procedures, frames with the supervisory function bits S encoded "11", and those encodings of the unnumbered function bits U in table 18, not identified in table 19, shall be identified as "invalid or not implemented" command and response control fields and shall be treated as defined in subclause 9.6.5.7.5.

Table 19: Commands and responses

Format	Commands	Responses	Encoding						
			8	7	6	5	4	3	2
Information transfer (I)	I information		N (R)	P	N (S)			0	
Supervisory (S)	RR (RX ready)	RR (RX ready)	N (R)	P/F	0	0	0	1	
	RNR (RX not ready)	RNR (RX not ready)	N (R)	P/F	0	1	0	1	
	REJ (reject)		N (R)	P/F	1	0	0	1	
Un-numbered (U)	SABM		0	0	1	P	1	1	1
		DM	0	0	0	F	1	1	1
		UI	0	0	0	P	0	0	1
		DISC	0	1	0	P	0	0	1
			UA	0	1	1	F	0	0
		FRMR	1	0	1	F	0	1	1

9.6.3.6.2 Information (I) commands

The information (I) command shall transfer, across a data link connection, sequentially numbered frames containing information fields provided by layer 3. This command shall be used in the multiple frame operation.

9.6.3.6.3 Set Asynchronous Balanced Mode (SABM) command

The SABM unnumbered command shall be used to place the addressed user side or network side into modulo 8 multiple frame acknowledged operation.

An information field may be used with the SABM command. Layer 3 shall indicate when an information field is to be included (see subclause 9.6.5.4.1 for procedures).

A data link layer entity shall confirm acceptance of an SABM command by the transmission at the first opportunity of a UA response. Upon acceptance of this command, the data link layer entities shall send state variable V(S), acknowledge state variable V(A), and receive state variable V(R), all set to "0". The transmission of an SABM command shall indicate the clearance of any exception condition, in particular a busy condition that was reported by the earlier transmission of an RNR frame by that same data link layer entity.

Previously transmitted I frames that are unacknowledged when this command is actioned shall remain unacknowledged and shall be discarded. It shall be the responsibility of a higher layer (for example layer 3) to recover from the possible loss of the contents of such I frames.

NOTE: SABM commands with information fields are only used in the AS to GS direction and only in order to establish a data link for contention resolution after the initial establishment of a layer 1 connection. The SABM command may contain any information field as received from layer 3. However the SABM does not contain layer 3 message units which have to be segmented.

#### **9.6.3.6.4 DISconnect (DISC) command**

The DISC shall be an unnumbered command and shall be transmitted in order to terminate the multiple frame operation (see also subclause 9.6.5.4.5.4 for an alternative mechanism).

No information field shall be permitted with the DISC command.

Prior to actioning the command, the data link layer entity receiving the DISC command shall confirm the acceptance of a DISC command by the transmission of a UA response. The data link layer entity sending the DISC command shall terminate the multiple frame operation when it receives the acknowledging UA or Disconnected Mode (DM) response.

Previously transmitted I frames that are unacknowledged when this command is actioned remain unacknowledged and shall be discarded. It is the responsibility of a higher layer (for example, layer 3) to recover from the possible loss of the contents of such I frames.

#### **9.6.3.6.5 Unnumbered information (UI) command**

When a layer 3 entity requests unacknowledged information transfer, the UI unnumbered command shall be used to send information to its peer without affecting data link layer variables. UI command frames shall not carry a sequence number. Therefore, the UI frame may be lost without notification to the layer 3 entity if a data link exception occurs during transmission of the command.

#### **9.6.3.6.6 Receive ready (RR) command/response**

The receive ready (RR) supervisory frame is used by a data link layer entity to:

- a) indicate it is ready to receive an I frame;
- b) acknowledge previously received I frames up to and including  $N(R) - 1$ ;
- c) clear a busy condition that was indicated by the earlier transmission of an Receive Not Ready (RNR) frame by that same data link layer entity.

In addition to indicating the status of a data link layer entity, the RR command with the P bit set to "1" may be used by the data link layer entity to ask for the status of its peer data link layer entity.

No information field shall be permitted with the RR command/response.

#### **9.6.3.6.7 Reject (REJ) command/response**

The Reject (REJ) supervisory frame shall be used by a data link layer entity to request re-transmission of I frames starting with the frame numbered  $N(R)$ . The value of  $N(R)$  in the REJ frame shall acknowledge I frames numbered up to and including  $N(R)-1$ . New I frames pending initial transmission shall be transmitted following the re-transmitted I frames.

Only one REJ exception condition for a given direction of information transfer shall be established at a time. The REJ exception condition shall be cleared (reset) upon the receipt of an I frame with an  $N(S)$  equal to the  $N(R)$  of the REJ frame.

The transmission of a REJ frame shall also indicate the clearance of any busy condition within the sending data link layer entity that was reported by the earlier transmission of an RNR frame by that same data link entity.

In addition to indicating the status of a data link layer entity, the REJ command with the P bit set to "1" may be used by the data link layer entity to ask for the status of its peer data link layer entity.

No information field shall be permitted with the REJ command/response.

#### **9.6.3.6.8 Receive not ready (RNR) command/response**

The RNR supervisory frame shall be used by a data link layer entity to indicate a busy condition; that is, a temporary inability to accept additional incoming I frames. The value of N(R) in the RNR frame shall acknowledge I frames numbered up to and including N(R)-1.

Acknowledgement of subsequent I frames transmitted before the indication of the peer receiver busy is received, shall be made in subsequent exchanges if they arrive after the peer receiver busy condition has been cleared.

In addition to indicating the status of a data link layer entity, the RNR command with the P bit set to "1" may be used by the data link layer entity to ask for the status of its peer data link layer entity.

No information field shall be permitted with the RNR command/response.

#### **9.6.3.6.9 Unnumbered Acknowledgement (UA) response**

The UA unnumbered response shall be used by a data link layer entity to acknowledge the receipt and acceptance of the mode setting commands (SABM or DISC). Received mode setting commands shall not be actioned until the UA response has been transmitted.

An information field shall be permitted with the UA response, i.e. if an SABM command with an information field is received and the SABM is to be acknowledged, the UA response to that command shall contain the same information field as received in the SABM command.

The transmission of the UA response shall indicate the clearance of any busy condition that was reported by an earlier transmission of an RNR frame by that same data link layer entity.

#### **9.6.3.6.10 Disconnected Mode (DM) response**

The DM unnumbered response shall be used by a data link layer entity to report to its peer that the data link layer is in a state such that multiple frame operation cannot be performed. A data link layer entity shall transmit a DM response to any valid command received which it cannot action.

No information field shall be permitted with the DM response.

#### **9.6.3.6.11 FRaMe Reject (FRMR) response**

The FRMR unnumbered response shall be received by a data link layer entity when a report of an error condition not recoverable by re-transmission of the identical frame occurs, i.e. at least one of the following error conditions resulting from the receipt of a valid frame:

- the receipt of a command or response control field that is undefined or not implemented;
- the receipt of a supervisory or unnumbered frame with incorrect length;
- the receipt of an invalid N(R);
- an I frame with incorrect use of the M bit;
- an I frame with an invalid length field.

An undefined control field shall be any of the control field encodings that are not identified in table 18.

A valid N(R) value shall be in the range V(A) N(R)  $\mu$  V(S).

NOTE: An information field which immediately follows the control field and consists of three octets is returned with this response and provides the reason for the FRMR response. This information field format is given in figure 37.

	8	7	6	5	4	3	2	1
rejected frame control field								
V(S)				V(R)			C/R	0
0	0	0	0	z	y	x	w	

**Figure 37: FRMR information field format**

The rejected frame control field shall be the control field of the received frame which caused the frame reject.

V(S) shall be the current send state variable value on the AS side or GS side reporting the rejection condition.

C/R shall be set to 1 if the frame rejected was a response and set to "0" if the frame rejected was a command.

V(R) shall be the current receive state variable value on the AS side or GS side reporting the rejection condition.

W set to 1 shall indicate that the control field received and returned was undefined or not implemented.

X set to 1 shall indicate that the control field received and returned was invalid as the frame contained an information field which is not permitted with this frame or is a supervisory or unnumbered frame with incorrect length. Bit W shall be set to 1 in conjunction with this bit.

Y set to 1 shall indicate that an I frame was received with invalid length field or with incorrect use of the M bit on the AS side or GS side reporting the rejection condition.

Z set to 1 shall indicate that the control field received and returned contained an invalid N(R).

#### **9.6.4 Elements for layer-to-layer communication**

##### **9.6.4.1 General**

Communication between layers and between the data link layer and layer 3 shall be accomplished by means of primitives.

##### **9.6.4.1.1 Generic names**

The generic name specifies the activity that the identified layer should perform. Table 20 illustrates the primitives referenced in this ETS applicable to DCCH or BCCH channels.

Table 20: Service primitives

Generic name and type	Message Unit	Error Cause	Release Mode	Establish Mode	Message Unit Contents
DL-ESTABLISH-REQUEST	o			x	Layer 3 message for ambiguity resolution
DL-ESTABLISH-INDICATION	o				Layer 3 message for ambiguity resolution
DL-ESTABLISH-CONFIRM					
DL-RELEASE-REQUEST			x		
DL-RELEASE-INDICATION	x				Outstanding acknowledgements or unserved DL-DATA-REQUEST primitives
DL-RELEASE-CONFIRM	x				Outstanding acknowledgement or unserved DL-DATA-REQUEST primitives
DL-DATA-REQUEST	x				Layer 3 peer to peer message
DL-DATA-INDICATION	x				Layer 3 peer to peer message
DL-UNIT-DATA-REQUEST	x				Layer 3 peer to peer message
DL-UNIT-DATA-INDICATION	x				Layer 3 peer to peer message
DL-SUSPEND-REQUEST					
DL-SUSPEND-INDICATION					
DL-SUSPEND-CONFIRM					
DL-RESUME-REQUEST	x				Layer 3 peer to peer message
DL-RESUME-CONFIRM					

(continued)



**Table 20 (concluded): Service primitives**

Generic name and type	Message Unit	Error Cause	Release Mode	Establish Mode	Message Unit Contents
PH-DATA-REQUEST	x				Layer 2 peer to peer message
PH-DATA-INDICATION	x				Layer 2 peer to peer message
PH-G2-INDICATION					
MDL-ERROR-INDICATION		x			
MDL-RELEASE-REQUEST					
MDL-ALLOCATE					
PH-READY-TO-SEND					
o: indicates that the parameter is mandatory x: indicates that the parameter is optional					

The primitive generic names that are defined in this ETS are listed below. Those prefixed with "PH-" are included for information only; they are specified in clause 8.

**9.6.4.1.1.1 DL-ESTABLISH**

The DL-ESTABLISH primitives shall be used to request, confirm and indicate the outcome of the procedures for establishing multiple frame operation.

**9.6.4.1.1.2 DL RELEASE**

The DL-RELEASE primitives shall be used to request, confirm and indicate the outcome of the procedures for terminating a previously established multiple frame operation.

In the case of a data link layer malfunction, layer 3 shall be notified by a RELEASE indication.

**9.6.4.1.1.3 DL-DATA**

The DL-DATA primitives shall be used to pass layer 3 message units which are to be transmitted, or have been received, using multiple frame acknowledged operation.

**9.6.4.1.1.4 DL-UNIT DATA**

The DL-UNIT DATA primitives shall be used to pass layer 3 message units which are to be transmitted, or have been received, using unacknowledged operation.

**9.6.4.1.1.5 DL-SUSPEND**

The DL-SUSPEND primitive shall be used to request the procedure for terminating a previously established multiple frame operation in a way that preserves any unacknowledged layer 3 messages.

**9.6.4.1.1.6 DL-RESUME**

The DL-RESUME primitives shall be used to request and confirm the establishment of multiple frame operation following a previous suspension without loss of layer 3 messages.

#### **9.6.4.1.1.7 Management Data Link (MDL)-RELEASE**

The MDL-RELEASE primitives shall be used by RRM to request local end termination of a previously established acknowledged mode operation.

#### **9.6.4.1.1.8 MDL-ERROR**

The MDL-ERROR primitives shall be used to notify RRM that an error has occurred, detected as a result of communication with the data link peer entity which cannot be corrected by the data link layer.

#### **9.6.4.1.1.9 PH-DATA**

The PH-DATA primitives shall be used to pass message units containing frames used for data link layer peer-to-peer communications to and from the physical layer.

#### **9.6.4.1.1.10 MDL-ALLOCATE**

The MDL ALLOCATE primitives are used to notify layer 2 that a physical resource exists for the specific data link entity.

#### **9.6.4.1.1.11 PH-READY-TO-SEND**

The PH-READY-TO-SEND primitive is sent by layer 1 to layer 2 to trigger the sending of data units to layer 1. It is passed to layer 2 immediately before a new G2 frame is transmitted.

#### **9.6.4.1.2 Primitive types**

The primitives used by layer 2 shall be REQUEST, INDICATION, RESPONSE or CONFIRM. The conventions for using these primitive types are shown in subclause 9.4.

#### **9.6.4.1.3 Parameter definition**

##### **9.6.4.1.3.1 Priority indicator**

Since several SAPs may exist on the GS side or AS side, protocol message units sent by one SAP may contend with those of other service access points for the physical resources available for message transfer. A priority indicator shall be used to determine which message unit shall have greater priority when contention exists.

The priority between messages is in accordance with the SAPI value as follows:

- Highest priority: SAPI = 0; then SAPI = 1; then SAPI = 2;
- Lowest priority: SAPI = 3.

##### **9.6.4.1.3.2 Message unit**

The message unit shall contain additional layer-to-layer information concerning actions and results associated with requests. In the case of the DATA and UNIT DATA primitives, the message unit shall contain the requesting layer peer-to-peer messages. For example, the DL-DATA message unit shall contain the layer 3 message unit; the PH-DATA message unit shall contain the data link layer frame.

The operations across the data link layer/layer 3 boundary shall be such that the layer sending the DATA or UNIT DATA primitive can assume a temporal order of the bits within the message unit and that the layer receiving the primitive can reconstruct the message with its assumed temporal order.

#### **9.6.4.1.3.3 Release mode**

The release mode parameter shall be used to enable the data link layer to operate in different release modes depending on whether the data link shall be released in the normal way or that a local end release shall take place on command from layer 3. The values of the parameter shall be:

- normal;
- local end release.

#### **9.6.4.1.3.4 Error cause**

This parameter shall be used by the data link layer to report procedure errors to layer 3. The following causes may be reported:

- timer T200 expired N200+1 times: data link cannot recover;
- unsolicited UA response;
- unsolicited DM response;
- unsolicited DM response in multiple frame state: data link cannot recover;
- unsolicited supervisory response;
- sequence error: data link cannot recover;
- U frame with incorrect parameters;
- S frame with incorrect parameters;
- I frame with incorrect use of M bit: data link cannot recover;
- I frame with incorrect length: data link cannot recover;
- frame not defined or not implemented: data link cannot recover;
- FRMR response received: data link cannot recover;
- link quality unacceptable: data link cannot recover;
- supervisory or unnumbered frame with incorrect length: data link cannot recover.

#### **9.6.4.1.3.5 Establish mode**

This parameter shall be used in the AS to indicate to the data link layer the type of establishment that shall be required. The parameter shall take the following values:

- normal;
- contention resolution.

#### **9.6.4.2 Primitive procedures**

The procedures in the AS and the GS for invoking and providing a service are described in subclause 9.4. An example of their use may be found in clause 10.

## 9.6.5 Definition of the peer-to-peer procedures of the data link layer

### 9.6.5.1 General

The procedures for use by the data link layer are specified in the following subclauses. The procedures shall apply to all signalling and data transfer between layer 3 entities.

The elements of procedure (frame types) which apply shall be:

- 1) for unacknowledged information transfer on BCCH/DCCH: UI-command;
- 2) for multiple-frame acknowledged information transfer on DCCH:

- SABM-command;
- UA-response;
- DM-response;
- DISC-command;
- RR-command/response;
- RNR-command/response;
- REJ-command/response;
- I-command;
- FRMR-response.

For handling of timers the terminology of CCITT Recommendation Z.100 [17] is used:

- a) Set <timer name> means that:
  - if the timer is inactive, the timer becomes active, ie a timer value is associated with the timer and it starts running;
  - if the timer is active, the timer is first reset, as in b) below and then set as in a) above;
- b) Reset <timer name> means that:
  - if the timer is active, the timer becomes inactive, ie. the association with the timer value is lost and it stops running;
  - if the timer is inactive, it remains inactive.

### 9.6.5.2 Procedure for the use of the P/F bit

#### 9.6.5.2.1 Unacknowledged information transfer

For unacknowledged information transfer, the P/F bit is not used and shall be set to "0".

#### 9.6.5.2.2 Acknowledged multiple frame information transfer

A data link layer entity receiving an SABM, DISC, RR, RNR, REJ or I command with the P bit set to "1", shall set the F bit to "1" in the next response frame it transmits, as defined in table 21.

**Table 21: Immediate response operation of P/F bit**

Command received with P bit = 1	Response transmitted with F bit = 1
SABM, DISC	UA, DM
I, RR, RNR, REJ	RR, RNR, REJ, DM, FRMR

### **9.6.5.3 Procedures for unacknowledged information transfer**

#### **9.6.5.3.1 General**

The procedures which apply to the transmission of information in unacknowledged operation are defined below.

No data link layer error recovery procedures are defined for unacknowledged operation.

#### **9.6.5.3.2 Transmission of unacknowledged information**

Unacknowledged information is passed to the data link layer by layer 3 using the primitive DL-UNIT-DATA-REQUEST. The layer 3 message unit shall be transmitted in a UI command frame.

NOTE 1: The term "transmitted in a UI command frame" refers to the delivery of a UI frame by the data link layer to the physical layer.

NOTE 2: UI frames with the length indicator set to "0" may be used as fill frames, see subclause 9.6.5.4.2.3.

The P bit shall be set to "0".

#### **9.6.5.3.3 Receipt of unacknowledged information**

On receipt of a UI command frame with a SAPI which is supported by the receiver, the contents of the information field shall be passed to the layer 3 entity identified by the SAPI using the data link layer to layer 3 primitive DL-UNIT-DATA-INDICATION. UI frames with invalid SAPI values shall be discarded.

UI frames may be received with the length indicator set to 0. Such frames shall be ignored.

### **9.6.5.4 Procedures for establishment and release of multiple frame operation**

#### **9.6.5.4.1 Establishment of multiple frame operation**

##### **9.6.5.4.1.1 General**

The following procedures shall be used to establish multiple frame operation between the GS and a designated AS entity.

Layer 3 shall initiate the establishment procedure after a physical channel supporting multiple frame operation has been allocated to the AS (see subclause 9.6.5.1).

There are two establishment procedures specified in this subclause, normal establishment and contention resolution.

In the procedure for normal establishment the SABM shall not contain an information field. Layer 3 shall indicate a request for normal establishment by the use of the DL-ESTABLISH-REQUEST primitive as defined in subclauses 9.6.5.4.1.2 and 9.6.5.4.1.3.

In the procedure for contention resolution the SABM shall contain an information field. The procedure shall be initiated by the AS. Layer 3 shall indicate a request for contention resolution establishment by the use of the DL-ESTABLISH-REQUEST primitive containing the layer 3 message unit and as defined in subclauses 9.6.5.4.1.4 and 9.6.5.4.1.5.

Re-establishment shall be initiated using the normal establishment procedure, as a result of the data link layer procedure defined in subclause 9.6.5.6.

#### 9.6.5.4.1.2 Normal establishment procedures

A data link layer entity shall initiate a request for the multiple frame operation to be set by transmitting the SABM command with the P bit set to "1". Since the DL-ESTABLISH-REQUEST primitive does not contain a layer 3 message unit, the length indicator, L, shall be set to "0".

All existing exception conditions shall be cleared, the re-transmission counter shall be reset, and timer T200 shall then be set (timer T200 is defined in subclause 9.6.5.8.1).

NOTE: The establishment procedure implies the discard of any outstanding DL-DATA-REQUEST primitive which has been invoked prior to the DL-ESTABLISH-REQUEST. It also implies the discard of any segmented layer 3 message unit for which the last segment has not been received (see subclause 9.6.5.5.2 for the re-assembly procedure).

All frames other than unnumbered frame formats received during the establishment procedures shall be ignored.

A data link layer entity receiving an SABM, if it is able to enter the multiple frame established state, shall:

- respond with an UA response with the F bit set to the same binary value as the P bit in the received SABM command, and with the length indicator, L, set to "0";
- set the send state variable V(S), receive state variable V(R) and acknowledge state variable V(A) to 0;
- enter the multiple frame established state and inform the associated layer 3 entity using the primitive DL-ESTABLISH-INDICATION;
- clear all existing exception conditions;
- clear an existing peer receiver busy condition.

If the data link layer entity is unable to enter the multiple frame established state, it shall respond to the SABM command with a DM response with the F bit set to the same binary value as the P bit in the received SABM command.

Upon reception of the UA response with the F bit set to "1", the originator of the SABM command shall:

- reset timer T200;
- set the send state variable V(S), the receive state variable V(R) and the acknowledge state variable V(A) to "0";
- enter the multiple frame established state and inform the associated layer 3 entity using the primitive DL-ESTABLISH-CONFIRM.

A UA response with the F bit set to "0" shall be ignored.

Upon reception of a DM response with F bit set to "1", the originator of the SABM command shall indicate this to the layer 3 entity by means of the primitive DL-RELEASE-INDICATION and reset timer T200. DM responses with the F bit set to "0" shall be ignored.

#### 9.6.5.4.1.3 Procedure on expiry of timer T200: normal establishment

If timer T200 expires before the UA or DM response is received, the data link layer entity shall:

- re-transmit the SABM command as above;
- set timer T200; and
- increment the re-transmission counter.

After re-transmission of the SABM command N200 times, the data link layer entity shall indicate this to the associated layer 3 entity by means of the primitive DL-RELEASE-INDICATION. The RRM entity shall be informed by using the primitive MDL-ERROR-INDICATION.

#### 9.6.5.4.1.4 Contention resolution establishment procedure

This procedure shall be initiated by the AS for establishing a data link in order to resolve contention after an initial layer 1 channel is established to a GS. Layer 3 shall decide when this establishment procedure shall be used and will request the data link layer to initiate the procedure by a DL-ESTABLISH-REQUEST primitive containing the message unit and with the establish mode parameter set to contention resolution.

The data link layer shall, however, ignore any such request if it is not in the idle state when the request is received.

The data link layer entity in the AS shall initiate the establishment by transmitting an SABM command with the P bit set to "1". The SABM command shall contain the layer 3 message unit received in the DL-ESTABLISH-REQUEST primitive and the length indicator, L, shall be set to the appropriate value.

The information field of the SABM command shall be stored in the data link layer entity of the AS. The information field shall be removed when the data link layer enters the multiple frame established state or the idle state.

All existing exception conditions shall be cleared, the re-transmission counter shall be reset, and timer T200 shall be set.

The peer data link layer entity in the GS receiving the SABM shall, if the entity is in the idle state and an "establishment in progress" flag has not been set:

- set the "establishment in progress" flag;
- store the information field received in the SABM command;
- respond, at the earliest possible opportunity, with a UA response with:
  - the F bit set to the same binary value as the P bit received in the SABM command,
  - the length indicator, L, set to the same value as that contained in the SABM command,
  - the same information field as that contained in the SABM command;
- set the send state variable V(S), the receive state variable V(R) and the acknowledge state variable V(A) to 0;
- enter the "contention resolution receiver" state and inform the layer 3 entity using the DL-ESTABLISH-INDICATION primitive. The primitive shall contain the received layer 3 message unit;
- clear all existing exception conditions.

If an SABM command with an information field is received when the "establishment in progress" flag has been set, the data link layer entity in the GS shall compare the stored information field with the information

field received in the SABM command. If they are not identical, the SABM command shall be ignored. If they are identical, the data link entity shall respond, at the earliest possible opportunity, with a UA response with:

- the F bit set to the same binary value as the P bit contained in the SABM command;
- the length indicator, L, set to the same value as that contained in the SABM command;
- the stored information field.

NOTE 1: This case corresponds to a re-transmission of the SABM command by the AS (see subclause 9.6.5.4.1.5).

NOTE 2: This procedure is very different from the normal establishment procedure; in the latter case the reception of a subsequent SABM frame triggers a re-establishment (see subclause 9.6.5.6).

In a contention resolution state, if primitive DL-DATA-REQUEST, DL-RELEASE-REQUEST or DL-ESTABLISH-REQUEST, or SABM frames without data, DISC or DM are received they shall be processed in the same way as for multiple frame operation. The "establish in progress" flag shall be deleted and the stored information field deleted.

If a data link layer entity in the GS receives a SABM command, with an information field, and the entity is in a state other than the idle state, or the contention resolution receiver state, the SABM command shall be ignored.

The data link layer entity in the GS shall remove the "establishment in progress" flag and delete the stored information field when:

- an I frame or supervisory frame is received, the data link layer entity shall enter the multiple frame established state and process the frame as specified for operation in the multiple frame established state. If N(R) in the frame is invalid (refer to subclause 9.6.3.5.2.3), the GS shall initiate abnormal release using the procedure of subclause 9.6.5.6;
- a DL-RELEASE-REQUEST is received from layer 3 with a parameter indicating that a normal release shall take place. In this case the data link entity shall initiate the normal release procedure of subclause 9.6.5.4.5.2.
- a MDL-RELEASE-REQUEST or a DL-RELEASE-REQUEST with a parameter indicating that a local end release shall take place. In this case the data link layer entity shall follow the local end release procedure of subclause 9.6.5.4.5.4.

The procedure when awaiting acknowledgement in the AS shall be as follows:

- upon reception of a UA response containing an information field and with the F bit set to "1", the data link layer entity in the AS shall compare the stored information field with the information field received in the UA response. If the two fields are identical, the data link layer entity shall:
  - reset timer T200;
  - set the send state variable V(S), the receive state variable V(R) and the acknowledge state variable V(A) to 0;
  - delete the stored information field;



- enter the multiple frame established state and inform the layer 3 entity using the DLESTABLISH-CONFIRM primitive.
- if the two fields are different, the data link layer entity shall:
  - reset timer T200;
  - delete the stored information field;
  - enter the idle state and inform the layer 3 entity using the DLRELEASE-INDICATION primitive.

#### **9.6.5.4.1.5 Procedure on expiry of timer T200; contention resolution (AS only)**

If timer T200 expires before a UA response has been received, the data link layer entity shall:

- re-transmit the SABM as in subclause 9.6.5.4.1.4;
- set timer T200; and
- increment the re-transmission counter by 1.

After re-transmission of the SABM command N200 times, the data link layer shall enter the idle state and issue a DLRELEASEINDICATION primitive to layer 3 and a MDL-ERROR-INDICATION to RRM cause "timer T200 expired N200+1 times; data link cannot recover".

#### **9.6.5.4.2 Information transfer**

##### **9.6.5.4.2.1 General requirements**

Having either transmitted the UA response to a received SABM command or received the UA response to a transmitted SABM command, I frames and supervisory frames shall be transmitted and received according to the procedures described in subclause 9.6.5.5.

If a SABM command is received while in the multiple frame established state, the data link layer entity shall conform to the re-establishment procedure described in subclause 9.6.5.6.

On receipt of a UI command, the procedures defined in subclause 9.6.5.3 shall be followed.

##### **9.6.5.4.2.2 Error conditions**

The action to be taken on receipt of unsolicited response frames is summarised in table 22 below.

**Table 22: Actions taken on receipt of unsolicited response frames**

Response frame	Multiple frame established	Timer recovery condition
UA F = 1	MDL-ERROR-INDICATION (unsolicited UA response)	MDL-ERROR-INDICATION (unsolicited UA response)
UA F = 0	MDL-ERROR-INDICATION (unsolicited UA response)	MDL-ERROR-INDICATION (unsolicited UA response)
Response frame	Multiple frame established	Timer recovery
DM F = 1	MDL-ERROR-INDICATION (unsolicited DM response)	MDL-ERROR-INDICATION (unsolicited DM response in multiple frame established state data link cannot recover)
DM F = 0	MDL-ERROR-INDICATION (unsolicited DM response in multiple frame state: data link cannot recover)	MDL-ERROR-INDICATION (unsolicited DM response in multiple frame state: data link cannot recover)
Supervisory response F' = 1	MDL-ERROR-INDICATION (unsolicited supervisory response)	Normal
Supervisory response F' = 0	normal	Normal

#### 9.6.5.4.2.3 Fill frames

In periods where no other frames are scheduled for transmission and something must be sent on the radio path, a UI command with length 0 and SAPI of 0 shall be transmitted.

#### 9.6.5.4.3 Suspension and resumption of multiple frame operation

##### 9.6.5.4.3.1 General

These procedures shall provide a mechanism to avoid loss of messages passed from layer 3 to layer 2 which might occur if layer 3 used DL-RELEASE-REQUEST/DL-ESTABLISH-REQUEST. These procedures may however, result in duplication of layer 3 messages, which layer 3 shall recover from.

NOTE: Messages transmitted by the peer entity for which the peer entity has not received an acknowledgement will be lost.

The use of these procedures is described in subclause 9.4.

##### 9.6.5.4.3.2 Suspension

A layer 3 entity shall indicate a request for the suspension of multiple frame operation by use of the DL-SUSPEND-REQUEST primitive. The layer 2 entity, on receipt of this primitive, shall act as follows:

- no further I frames shall be transmitted;

- any layer 3 messages for which the last segment has not been acknowledged are retained, with the original sequence preserved;
- a DL-SUSPEND-CONFIRM is returned to layer 3;
- the timer T200 shall be reset.

The data link layer entity shall enter the suspended state.

In the suspended state if the primitive MDL-RELEASE-REQUEST is received, it shall be processed in the same way as for multiple frame operation.

#### **9.6.5.4.4 Resumption of multiple frame operation**

##### **9.6.5.4.4.1 General**

This procedure shall be initiated by the DL-RESUME-REQUEST primitive.

A data link layer entity shall initiate a request for the multiple frame operation to be set by transmitting the SABM command with the P bit set to "1". The SABM command shall contain the layer 3 message unit received in the DL-RESUME-REQUEST primitive and the length indicator shall be set to the appropriate value.

All existing exception conditions shall be cleared, the re-transmission counter shall be reset, and timer T200 shall then be started (timer T200 is defined in subclause 9.6.5.8.1).

Any outstanding layer 3 messages saved by a previous DL-SUSPEND-REQUEST primitive shall be retained, with the exception of a message unit sent by a previous DL-RESUME-REQUEST primitive. A layer 3 message unit parameter of the DL-RESUME-REQUEST shall be transmitted prior to any saved layer 3 messages.

All frames, other than unnumbered frame formats, received during the establishment procedures shall be ignored.

Upon reception of the UA response with the F bit set to "1", the originator of the SABM command shall:

- reset timer T200;
- set the send state variable V(S), the receive state variable V(R) and the acknowledge state variable V(A) to "0";
- enter the multiple frame established state and inform the associated layer 3 entity using the primitive DL-RESUME-CONFIRM.

A UA response with the F bit set to "0" shall be ignored.

Upon reception of a DM response with F bit set to "1", the originator of the SABM command shall indicate this to the layer 3 entity by means of the primitive DL-SUSPEND-INDICATION and reset timer T200. DM responses with the F bit set to "0" shall be ignored.

##### **9.6.5.4.4.1 Procedure on expiry of timer T200**

If timer T200 expires before the UA or DM response is received, the data link layer entity shall:

- re-transmit the SABM command as above;
- set timer T200; and
- increment the re-transmission counter.

After re-transmission of the SABM command N200 times, the data link layer entity shall indicate this to the associated layer 3 entity by means of the primitive DL-SUSPEND-INDICATION.

#### **9.6.5.4.5 Termination of multiple frame operation**

##### **9.6.5.4.5.1 General**

These procedures shall be used to terminate the multiple frame operation between the GS and a designated AS entity.

A layer 3 entity shall indicate a request for termination of the multiple frame operation by use of the DL-RELEASE-REQUEST primitive. The DL-RELEASE-REQUEST primitive shall contain a parameter indicating whether normal release or local end release shall take place. In the first case the data link layer shall initiate the normal release procedure in subclause 9.6.5.4.5.2.

In the second case the data link layer shall initiate the local end release procedure in subclause 9.6.5.4.5.4.

If a physical channel is disconnected at the physical layer, RRM shall request local end release by issuing an MDL-RELEASE-REQUEST primitive. The actions to be taken are defined in subclause 9.6.5.4.5.4.

All frames other than unnumbered frames received during the release procedure shall be ignored.

NOTE: For all modes of release the release procedure implies the discard of any outstanding DL-DATA-REQUEST primitive which has been invoked prior to the DL-RELEASE-REQUEST. It also implies the discard of any segmented layer 3 data units for which the last segment has not been received (see subclause 9.6.5.5.2 for the re-assembly procedure).

##### **9.6.5.4.5.2 Normal release procedure**

A data link layer entity shall initiate a request for release of multiple frame operation by transmitting the DISC with the P bit set to "1". Timer T200 shall then be set. The Re-transmission Counter (RC) shall be set to "0".

A data link layer entity receiving a DISC while in the multiple frame established state or timer recovery state shall transmit a UA response with the F bit set to the same binary value as the P bit in the received DISC. A DL-RELEASE-INDICATION shall be passed to layer 3, timer T200 shall be reset and the idle state shall be entered.

If the originator of the DISC command receives either:

- a UA response with the F bit set to "1"; or
- a DM response with F bit set to "1", indicating that the peer data link layer entity was in the idle state,

it shall reset timer T200 and shall inform the layer 3 entity using the primitive DL-RELEASE-CONFIRM.

The data link layer entity which issued the DISC shall enter the idle state. The conditions relating to this state are defined in subclause 9.6.5.4.6.

The DL-RELEASE-INDICATION or -CONFIRM primitives shall contain an indication whether or not there are outstanding acknowledgements or unserved DL-DATA-REQUEST primitives.

#### 9.6.5.4.5.3 Procedure on expiry of timer T200 for normal release

If timer T200 expires before a UA or DM response is received, the originator of the DISC command shall:

- re-transmit the DISC command as defined in subclause 9.6.5.4.5.2;
- set timer T200; and
- increment the re-transmission counter.

If the data link layer entity has not received the correct response as defined in subclause 9.6.5.4.5.2, after N200 attempts to recover, the data link layer entity shall enter the idle state and shall inform the layer 3 entity using the primitive DL-RELEASE-CONFIRM.

The value of N200 is defined in subclause 9.6.5.8.2.

#### 9.6.5.4.5.4 Local end release procedure

When receiving a DL-RELEASE-REQUEST primitive from layer 3 with the release mode parameter set to "local end release", the data link layer shall in all states:

- return a DL-RELEASE-CONFIRM primitive;
- enter the idle state without issuing any commands to the peer entity.

The DL-RELEASE-CONFIRM primitive shall contain an indication whether or not there are outstanding acknowledgements or unserved DL-DATA-REQUEST primitives.

When receiving an MDL-RELEASE-REQUEST primitive, the data link layer entity, when in the idle state, shall enter the null state. In all other states the data link layer shall:

- when there is no outstanding DL-RELEASE-REQUEST primitive, issue a DL-RELEASE-INDICATION primitive to layer 3;
- when there is an outstanding DL-RELEASE-REQUEST primitive, issue a DL-RELEASE-CONFIRM primitive to layer 3;
- enter the null state without issuing any commands to the peer entity.

NOTE: The null state is the state, as viewed from the data link layer, where no physical resource exists for the specific data link layer entity.

On receipt of a MDL-ALLOCATE-REQUEST primitive the data link entity shall leave the null state and enter the idle state.

#### 9.6.5.4.6 Idle state

While in the idle state:

- the receipt of a DISC command shall result in the transmission of a DM response with the F bit set to the value of the received P bit;
- the receipt of an I frame or supervisory frame with the P bit set to "1" shall result in the transmission of a DM response with the F bit set to "1" (as defined in subclause 9.6.5.2.2);
- the content of any received I frame shall be discarded;
- on receipt of an SABM command, the procedures defined in subclause 9.6.5.4.1 shall be followed;

- on receipt of UI commands, the procedures defined in subclause 9.6.5.3 shall be followed;
- all other frame types shall be discarded.

#### **9.6.5.4.7 Collision of unnumbered commands and responses**

##### **9.6.5.4.7.1 Identical transmitted and received commands**

If the transmitted and received unnumbered commands (SABM or DISC) are the same, the data link layer entities shall send the UA response in the next available frame. The indicated state (SABM or DISC) shall be entered after receiving the UA response. The data link layer entities shall notify its respective layer 3 entity by means of the appropriate indication primitive, ie DLESTABLISHCONFIRM or DL-RELEASE-CONFIRM.

##### **9.6.5.4.7.2 Different transmitted and received commands**

If the transmitted and received unnumbered commands (SABM or DISC) are different, the data link layer entities shall issue a DM response in the next available frame.

The data link layer entities shall notify its respective layer 3 entity by means of the DL-RELEASE-INDICATION primitive when a SABM command was issued and DL-RELEASE-CONFIRM primitive when a DISC command was issued.

Timer T200 shall be reset.

##### **9.6.5.4.7.3 Unsolicited DM response and SABM or DISC command**

In order to avoid misinterpretation of the DM response received, a data link layer entity shall always send its SABM or DISC command with the P bit set to "1".

A DM response with the F bit set to "0" colliding with the SABM or DISC command shall be ignored.

#### **9.6.5.5 Procedures for information transfer in multiple frame operation**

The procedures which shall apply to the transmission of an I frame are defined below.

NOTE: The term "transmission of an I frame" refers to the delivery of an I frame by the data link layer to the physical layer.

##### **9.6.5.5.1 Transmitting I frames**

Information received by the data link layer entity from a layer 3 entity by means of a DL-DATA-REQUEST primitive shall be transmitted in one or more I frames. If the layer 3 message unit consists of N201 or fewer octets, the message unit shall be contained in one I frame. The M bit of subclause 9.6.3.3.4 shall be set to "0" in such I frames. If the layer 3 message unit exceeds N201 octets, the data link layer shall segment the message unit in such a way that all segments, with the possible exception of the last segment, consist of N201 octets.

Any DL-DATA-REQUEST primitive received while in the timer recovery condition shall be stored and serviced on clearance of this condition.

The M bit of subclause 9.6.3.3.4 shall be set to "1" for each segment except for the last segment for which the M bit shall be set to "0".

The parameter N201 is defined in subclause 9.6.5.8.3.

When transmitting an I frame, the control field parameters N(S) and N(R) shall be assigned the values of the send and receive state variables V(S) and V(R), respectively. The value of the send state variable V(S) shall be incremented by 1 at the end of the transmission of the I frame.

If timer T200 is not running when an I frame is ready for transmission, it shall be started. If timer T200 then expires, the procedures defined in subclause 9.6.5.5.7 shall be followed.

If the send state variable  $V(S)$  is equal to  $V(A)$  plus  $k$  (where  $k$  is the maximum number of outstanding I frames (see subclause 9.6.5.8.6), the data link layer entity shall not transmit any new I frames, but shall re-transmit an I frame as a result of the error recovery procedures as described in subclauses 9.6.5.5.4 and 9.6.5.5.7.

When the GS side or AS side is in the "own receiver busy" condition, they may transmit I frames, provided that a peer receiver busy condition does not exist.

NOTE: The term "own receiver busy" refers to the peer-to-peer flow control state in the data link layer entities.

#### 9.6.5.5.2 Receiving I frames

When a data link layer entity is not in an own receiver busy condition and receives a valid I frame whose send sequence number is equal to the current receive state variable  $V(R)$ , the data link layer entity shall:

- if the M bit is set to "0", concatenate it with any previously received frames with the M bit set to "1", and pass the complete layer 3 message unit to the layer 3 entity using the primitive DL-DATA-INDICATION;
- if the M bit is set to "1", store the information field of the frame and concatenate it with any previously received frames with the M bit set to "1", (i.e. no information shall be passed to the layer 3 entity);
- increment by 1 its receive state variable  $V(R)$ , and act as indicated below.

##### 9.6.5.5.2.1 P bit set to "1"

If the P bit of the received I frame was set to "1", the data link layer entity shall respond to its peer in one of the following ways:

- if the data link layer entity receiving the I frame is still not in an own receiver busy condition, it shall send an RR response with the F bit set to "1"; or
- if the data link layer entity receiving the I frame enters the own receiver busy condition upon the receipt of the I frame, it shall send an RNR response with the F bit set to "1".

##### 9.6.5.5.2.2 P bit set to "0"

If the P bit of the received I frame was set to "0" and:

- 1) if the data link layer entity is still not in an own receiver busy condition; and
  - if no I frame is available for transmission or if an I frame is available for transmission but a peer receiver busy condition exists, the data link layer entity shall transmit an RR response with the F bit set to "0"; or
  - if an I frame is available for transmission and no peer receiver busy condition exists, the data link layer entity shall transmit the I frame with the value of  $N(R)$  set to the current value of  $V(R)$  as defined in subclause 9.6.5.5.1 (this I frame then acknowledges the receipt of an I frame); or
- 2) if, on receipt of this I frame, the data link layer entity is now in an own receiver busy condition, it shall transmit an RNR response with the F bit set to "0".

When the data link layer entity is in an own receiver busy condition, it shall process any received I frame according to subclause 9.6.5.5.6.

### 9.6.5.5.3 Receiving acknowledgement

On receipt of a valid I frame or supervisory frame (RR, RNR, or REJ), even in the own receiver busy or timer recovery conditions, the data link layer entity shall treat the N(R) contained in this frame as an acknowledgement for all the I frames it has transmitted with an N(S) up to and including the received N(R)-1. The value of the acknowledge state variable V(A) shall be set to the value of N(R). The data link layer entity shall reset the timer T200 on receipt of a valid I frame or supervisory frame with N(R) higher than V(A) (actually acknowledging some I frames), or an REJ with an N(R) equal to V(A).

If a supervisory frame with P bit set to "1" has been transmitted and not acknowledged, timer T200 shall not be reset.

Upon the receipt of a valid I frame, timer T200 shall not be reset if the data link layer entity is in the peer receiver busy condition.

If timer T200 has been reset by the receipt of an I, RR or RNR frame, and if there are outstanding I frames still unacknowledged, the data link layer entity shall set timer T200. If timer T200 then expires, the data link layer entity shall follow the recovery procedure as defined in subclause 9.6.5.5.7 with respect to the unacknowledged I frames.

If timer T200 has been reset by the receipt of an REJ frame, the data link layer entity shall follow the re-transmission procedures in subclause 9.6.5.5.4.

### 9.6.5.5.4 Receiving REJ frames

On receipt of a valid REJ frame the data link layer entity shall act as follows:

- 1) If it is not in the timer recovery condition:
  - clear any existing peer receiver busy condition;
  - set its send state variable V(S) and set its acknowledge state variable V(A) to the value of the N(R) contained in the REJ frame control field;
  - reset timer T200;
  - if it was an REJ command frame with the P bit set to "1", transmit an appropriate supervisory frame with the F bit set to "1" (see subclause 9.6.5.5.4.2);
  - transmit the corresponding I frame as soon as possible, as defined in subclause 9.6.5.5.1, taking into account the conditions given in subclause 9.6.5.5.4.1;
  - if it was an REJ response frame with the F bit set to "1", notify a protocol violation to the RRM entity by means of the MDL-ERROR-INDICATION primitive (cause: unsolicited supervisory response);
- 2) If it is in a timer recovery condition and it was an REJ response frame with the F bit set to "1":
  - clear any existing peer recovery condition;
  - clear the timer recovery condition;
  - set its send state variable V(S) and its acknowledge state variable V(A) to the value of the N(R) contained in the REJ frame control field;
  - reset timer T200;
  - transmit the corresponding I frame as soon as possible as defined in subclause 9.6.5.5.1, taking into account the conditions given in subclause 9.6.5.5.4.1;



- 3) If it is in a timer recovery condition and it was an REJ frame other than an REJ response with the F bit set to "1":
- clear any existing peer receiver busy condition;
  - set its acknowledge state variable V(A) to the value of the N(R) contained in the REJ frame control field; and
  - if it was an REJ command frame with the P bit set to "1", transmit an appropriate supervisory response frame with the F bit set to "1" (see subclause 9.6.5.5.4.2).

#### **9.6.5.5.4.1 Transmitting I frames**

When transmitting I frames the following conditions shall be observed:

- if the data link layer entity is transmitting a supervisory frame when it receives the REJ frame, it shall complete that transmission before commencing transmission of the requested I frame;
- if the data link layer entity is transmitting an SABM or DISC command or a UA or DM response when it receives the REJ frame, it shall ignore the request for re-transmission;
- if the data link layer entity is not transmitting a frame when the REJ is received, it shall immediately commence transmission of the requested I frame.

All outstanding unacknowledged I frames, commencing with the I frame identified in the received REJ frame, shall be transmitted. Other I frames not yet transmitted may be transmitted following the transmitted I frames.

#### **9.6.5.5.4.2 Response to supervisory command frames**

When receiving supervisory command frames with the P bit set to "1", the following responses with the F bit set to "1" shall be given:

- if the data link layer is in its own receiver busy condition, the appropriate supervisory response shall be RNR;
- if the data link layer entity is not in an own receiver busy condition, but is in an N(S) sequence error exception condition (ie an N(S) sequence error has been detected but a REJ frame has not yet been transmitted), the appropriate supervisory response shall be REJ;
- otherwise the appropriate supervisory frame shall be the RR frame.

#### **9.6.5.5.5 Receiving RNR frames**

After receiving a valid RNR command or response, provided that the data link layer entity is not engaged in a mode setting operation, the data link layer entity shall set a peer receiver busy condition.

For RNR commands/responses with the P/F bit set to "1", the following special conditions apply:

- if it was an RNR command with the P bit set to "1", it shall respond with an RR response with the F bit set to "1" if the data link entity is not in an own receiver busy condition, and shall respond with an RNR response with the F bit set to "1" if the data link layer entity is in an own receiver busy condition;
- if it was an RNR response with the F bit set to "1" and timer recovery condition exists, the timer recovery condition shall be cleared and the N(R) contained in this RNR response shall be used to update the send state variable V(S).

The data link layer entity shall take note of the peer receiver busy condition and not transmit any I frame towards the peer having indicated a busy condition.

The N(R) in any received supervisory command, irrespective of the setting of the P bit, shall not be used to update the send state variable V(S).

The data link layer entity shall then:

- treat the receive sequence number N(R) contained in the received RNR frame as an acknowledgement for all the I frames that have been transmitted or re-transmitted with an N(S) up to and including N(R)-1, and set its acknowledge state variable V(A) to the N(R) contained in the RNR frame; and
- set timer T200 unless a supervisory response frame with the F bit set to "1" is still expected.

If timer T200 expires, the data link layer entity shall:

- if it is not yet in a timer recovery condition, enter a timer recovery condition, and set the re-transmission count variable to 0;
- if it is already in a timer recovery condition, add one to its re-transmission count variable.

The data link layer entity shall then:

- if the value of the re-transmission count variable is less than N200, transmit an appropriate supervisory command (see subclause 9.6.5.5.4.2) with the P bit set to "1", and set timer T200; or
- if the value of the re-transmission count variable is equal to N200, it shall initiate the abnormal release procedure described in subclause 9.6.5.6.6. RRM shall be notified via the MDL-ERROR-INDICATION primitive with cause "timer T200 expired N200+1 times: data link cannot recover".

The peer data link layer entity receiving the supervisory frame with the P bit set to "1" shall respond, at the earliest opportunity, with the appropriate supervisory response frame (see subclause 9.6.5.5.4.2) with the F bit set to "1" to indicate whether or not its own receiver busy condition still exists.

Upon receipt of the supervisory response with the F bit set to "1", the data link layer entity shall reset timer T200, and:

- if the response is an RR or REJ response, the peer receiver busy condition shall be cleared and the data link layer entity may transmit new I frames or re-transmit I frames as defined in subclauses 9.6.5.5.1 or 9.6.5.5.4 respectively; or
- if the response is an RNR response, the data link layer entity receiving the response shall proceed according to subclause 9.6.5.5.5, first paragraph.

If a supervisory command (RR, RNR, or REJ) with the P bit set to "0" or "1", or a supervisory response frame with the F bit set to "0" is received during the enquiry process, the data link layer entity shall:

- if the supervisory frame is an RR or REJ command or response frame with the F bit set to "0", clear the peer receiver busy condition and if the supervisory frame was a command with the P bit set to "1", transmit the appropriate supervisory response frame (see subclause 9.6.5.5.4.2) with the F bit set to "1". However, the transmission or re-transmission of I frames shall not be undertaken until the appropriate supervisory response frame with the F bit set to "1" is received or until the expiry of timer T200; or
- if the supervisory frame is an RNR command or an RNR response with the P/F bit set to "0", retain the peer receiver busy condition, and if the supervisory frame received was an RNR command with the P bit set to "1", transmit the appropriate supervisory response (see subclause 9.6.5.5.4.2) with the F bit set to "1".

Receiving an SABM command, the data link layer entity shall clear the peer receiver busy condition.

#### 9.6.5.5.6 Data link layer own receiver busy condition

When the data link layer entity enters an own receiver busy condition, it shall transmit an RNR frame at the earliest opportunity. The RNR frame may be:

- an RNR response with the F bit set to "0"; or
- if this condition is entered when receiving a command frame with the P bit set to "1", an RNR response frame with the F bit set to "1"; or
- if this condition is entered on expiry of timer T200, an RNR command with the P bit set to "1".

All received I frames with the P bit set to "0" shall be discarded, after updating the acknowledge state variable V(A).

All received supervisory frames with the P/F bit set to "0" shall be processed, including updating the acknowledge state variable V(A).

All received I frames with the P bit set to "1" shall be discarded, after updating the acknowledge state variable V(A). However, an RNR response frame with the F bit set to "1" shall be transmitted.

All received supervisory frames with the P bit set to "1" shall be processed including updating the acknowledge state variable V(A). An RNR response with the F bit set to "1" shall be transmitted.

To indicate to the peer data link layer entity the clearance of the own receiver busy condition, the data link layer entity shall transmit an RR frame, or, if a previously detected N(S) sequence error has not yet been reported, an REJ frame with the N(R) set to the current value of the receive state variable V(R).

The transmission of an SABM command or a UA response (in reply to an SABM command) shall also indicate to the peer data link layer entity the clearance of the own receiver busy condition.

#### 9.6.5.5.7 Waiting acknowledgement

The data link layer entity shall maintain an internal re-transmission count variable.

If timer T200 expires, the data link layer entity shall:

- if it is not yet in the timer recovery condition, enter the timer recovery condition and set the re-transmission count variable to 0; or
- if it is already in the timer recovery condition, add one to its re-transmission count variable.

The data link layer entity shall then:

- 1) If the value of the re-transmission count variable is less than N200:
  - re-transmit the last transmitted I frame (V(S)-1) with the P bit set to "1"; or
  - send the appropriate supervision frame with the P bit set to "1";
  - set timer T200;
- 2) If the value of the re-transmission count variable is equal to N200, indicate this by means of the primitive MDL-ERROR-INDICATION with cause "timer T200 expired N200+1 times: data link cannot recover" to the RRM.

NOTE: It is then the responsibility of layer 3 to release or re-establish the data link. The data link layer remains in the timer recovery state until further actions are taken by layer 3.

The timer recovery condition is cleared when the data link layer entity receives a valid supervisory frame response with the F bit set to "1". If the N(R) of the received supervisory frame is within the range from its current state variable V(A) to its send state variable V(S), it shall set its send state variable V(S) to the value of the received N(R).

Timer T200 shall be reset if the received supervisory frame response is an RR or REJ response. The data link layer entity shall then resume with I frame transmission or re-transmission, as appropriate.

Timer T200 shall be set if the received supervisory response is an RNR response, and the data link layer shall proceed with the enquiry process in accordance with subclause 9.6.5.5.5.

#### **9.6.5.6 Abnormal release and re-establishment of multiple frame operation**

##### **9.6.5.6.1 Criteria for re-establishment**

The procedures for re-establishing the multiple frame operation are initiated by:

- the receipt of a DL-ESTABLISH-REQUEST;
- the receipt, while in the multiple frame established or timer recovery state, of an SABM command.

##### **9.6.5.6.2 Criteria for abnormal release**

The procedures for abnormal release of the multiple frame operation shall be initiated by:

- the occurrence of N200 re-transmission failures while in the timer recovery condition (see subclause 9.6.5.7.3);
- the occurrence of a frame rejection condition as identified in subclause 9.6.5.7.5;
- the receipt, while in the multiple-frame mode of operation, of a FRMR response frame (see subclause 9.6.5.7.6);
- the receipt, while in the multiple-frame mode of operation, of an unsolicited DM response with the F bit set to "0" (see subclause 9.6.5.4.2.2).

##### **9.6.5.6.3 Procedures for re-establishment**

When the data link layer receives in the multiple frame established state or timer recovery state a DL-ESTABLISH-REQUEST primitive from layer 3 or an SABM (with L=0), the normal establishment procedure of subclause 9.6.5.4.1.2 shall be initiated. Any information frames in the I queue (including I frames for DL-DATA-REQUEST primitives and any received segmented layer 3 message units for which the last segment has not been received) shall be discarded.

A DL-ESTABLISH-INDICATION OR -CONFIRM primitive sent to layer 3 shall contain an indication whether or not there are outstanding acknowledgements or unserved DL-DATA-REQUEST primitives.

##### **9.6.5.6.4 Procedures for abnormal release**

The data link layer shall inform layer 3 that an exception condition exists from which the data link layer cannot recover. The information shall be provided in an MDL-ERROR-INDICATION primitive.

The release of the data link shall then be performed by layer 3 by either of the following primitives:

- DL-RELEASE-REQUEST (release mode = normal release). Then the data link layer shall follow the procedures of subclause 9.6.5.4.5.2;
- DL-RELEASE-REQUEST (release mode = local end release). Then the data link layer shall follow the procedure of subclause 9.6.5.4.5.4;

- MDL-RELEASE-REQUEST. Then the data link layer shall follow the procedure of subclause 9.6.5.4.5.4.

The data link layer shall remain in the same state (i.e. multiple frame established or timer recovery) until the primitive is received.

#### **9.6.5.7 Exception condition reporting and recovery for multiple frame operation**

Exception conditions may occur as the result of physical layer errors or data link layer procedural errors.

The error recovery procedures which are available to effect recovery following the detection of an exception condition at the data link layer are defined in this subclause.

##### **9.6.5.7.1 N(S) sequence error**

An N(S) sequence error exception condition occurs in the receiver when a valid I frame is received which contains an N(S) value which is not equal to the receive state variable V(R) at the receiver. The information field of all I frames whose N(S) does not equal the receive state variable V(R) shall be discarded.

The receiver shall not acknowledge (nor increment its receive state variable) the I frame causing the sequence error, nor any I frames which may follow, until an I frame with the correct N(S) is received.

A data link layer entity which receives one or more I frames having sequence errors but otherwise error-free, or subsequent supervisory frames (RR, RNR or REJ), shall use the control field information contained in the N(R) field and the P or F bit to perform data link control functions, e.g. to receive acknowledgement of previously transmitted I frames and to cause the data link layer entity to respond if the P bit is set to "1". Therefore, a re-transmitted I frame may contain an N(R) field value and P bit that are updated from, and therefore different from, the ones contained in the originally transmitted I frame.

The REJ frame shall be used by a receiving data link layer entity to initiate an exception condition recovery (re-transmission) following the detection of an N(S) sequence error.

Only one REJ exception condition for a given direction of information transfer shall be established at a time.

A data link layer entity receiving an REJ command or response shall initiate sequential transmission (re-transmission) of I frames starting with the I frame indicated by the N(R) contained in the REJ frame.

An REJ exception condition shall be cleared when the requested I frame is received or when an SABM or DISC command is received.

##### **9.6.5.7.2 N(R) sequence error**

An N(R) sequence error exception condition occurs in the transmitter when a valid supervisory frame or I frame is received which contains an invalid N(R) value. In this case the data link shall issue an MDL-ERROR-INDICATION with the cause "sequence error: data link cannot recover".

A valid N(R) shall be in the range  $V(A) \leq N(R) \leq V(S)$ .

The information field contained in an I frame which is correct in sequence and format but contains an invalid N(R) shall be delivered to layer 3 by means of the primitive DL\_DATA\_INDICATION if the M bit is cleared.

##### **9.6.5.7.3 Timer recovery**

If a data link layer entity, due to a transmission error, does not receive a single I frame or the last I frame(s) in a sequence of I frames, it will not detect an out-of-sequence exception condition and therefore shall not transmit a REJ frame.

The data link layer which transmitted the unacknowledged I frame(s) shall, on the expiry of timer T200, take appropriate recovery action as defined in subclause 9.6.5.5.7 to determine at which frame re-transmission must begin.

#### **9.6.5.7.4 Invalid frame condition**

Any frame which is invalid (as defined in subclause 9.6.2.9) shall be discarded.

#### **9.6.5.7.5 Frame rejection condition**

A frame rejection condition shall result from one of the conditions described in subclause 9.6.3.6.11. Upon occurrence of a frame rejection condition whilst in the multiple frame operation, the data link layer entity shall issue an MDL-ERROR-INDICATION with the appropriate cause, indicating that the data link cannot recover.

#### **9.6.5.7.6 Receipt of an FRMR response frame**

Upon receipt of an FRMR response frame in the multiple-frame mode of operation, the data link layer entity shall issue an MDL-ERROR-INDICATION with the cause "FRMR response received: data link cannot recover" and pass on the received peer message unit which shall indicate the cause of the frame rejection.

#### **9.6.5.7.7 Radio link failure condition**

If the criterion of subclause 8.10.8.4 is met, then an MDL-ERROR-INDICATION with cause "link quality unacceptable" shall be sent to RRM.

A frame shall be regarded as successfully decoded if the FCS is valid, see subclause 9.6.2.7.

#### **9.6.5.8 List of system parameters**

##### **9.6.5.8.1 Timer T200**

Timer T200 shall time out once a first period of 50 ms has elapsed followed by a second period of time the duration of which shall correspond to the time necessary to receive two G2 slot opportunities.

The first period of 50 ms shall start immediately after the last bit of the corresponding scheduled frame to be transmitted has actually been transmitted by the sending entity.

In the second period, only opportunities to receive G2 slots the first bit of which is actually received after the end of the 50 ms period are taken into account in the evaluation of the number of reception opportunities. If the second reception opportunity does not carry the expected response, timer T200 will time out.

To enable the latter condition to be detected, layer 1 shall pass a PH-G2-INDICATION primitive to layer 2 each time an opportunity to receive a G2 slot occurs. This primitive shall be sent by layer 1 regardless of whether or not a G2 slot is actually received. See also subclause 8.4.2.

##### **9.6.5.8.2 Maximum number of re-transmissions (N200)**

The default value shall be 5.

##### **9.6.5.8.3 Maximum number of octets in an information field (N201)**

In general the maximum number of octets in an information field shall be 8.

In the case of a frame received via a BCCH(D) channel the number of octets in the information field shall be increased to 10 (see subclause 9.6.2.2).

#### **9.6.5.8.4 Number of octets in a frame (N202)**

The number of octets in a frame N202 shall be 12.

#### **9.6.5.8.5 Maximum number of octets in a message unit parameter (N203)**

The default value for the maximum number of octets in a message unit parameter N203 shall be 260.

#### **9.6.5.8.6 Maximum number of outstanding I frames (k)**

The maximum number of outstanding I frames (k) shall be  $1 < k <= 7$ . except for SAPI=0, when the default shall be 3.

## **10 AS - GSS layer 3 specification**

### **10.1 Introduction**

#### **10.1.1 General**

The signalling layer 3 provides the functions to establish, maintain and terminate circuit-switched connections across the TFTS and other networks to which the TFTS is connected. It includes functions necessary for RRM.

The term "layer 3" or "signalling layer 3" is a general term used to refer to the procedures described in this clause.

The layer 3 is composed of two sub-layers, Connection Management (CM) sub-layer (functions for Call Control (CC) and Maintenance Resource (MR)) and the RRM sub-layer.

#### **10.1.2 Objectives**

The objectives of layer 3 shall provide the means for:

- the establishment, operation and release of a dedicated radio channel (RRM);
- establishment, maintaining and termination of circuit-switched calls (CC);
- maintenance signalling (MR).

#### **10.1.3 General characteristics**

##### **10.1.3.1 Technique of description**

The signalling layer 3 is described in terms of:

- services provided by the signalling layer 3;
- services assumed from the signalling layer 2;
- functions of the signalling layer 3.

The functions of the signalling layer 3 shall be performed by means of the signalling layer 3 protocols between two systems which represent the AS side and the GSS side of the radio interface as viewed by the AS. This subclause does not consider the distribution of signalling functions among the different entities of the AS and the GSS. The functions of layer 3 and its supporting lower layers shall provide the network service to the upper layers.

The same technique of description is used for the two sub-layers of layer 3.

### 10.1.3.2 Primitives

The services provided by the various sub-layers are described in this subclause. The elementary interactions among adjacent sub-layers are described by primitives and shall consist of the following four types:

- REQUEST;
- INDICATION;
- RESPONSE;
- CONFIRM.

### 10.1.3.3 Peer-to-peer communication

Exchange of information between two peers of signalling layer 3 shall be performed by means of the two sub-layer protocols. The information consisting of control information and user data shall be contained in Protocol Data Units (PDUs).

NOTE: A protocol is a set of rules and formats by which PDUs are exchanged between the two peers.

## 10.2 Structure of signalling functions

### 10.2.1 Basic groups of functions

Signalling layer 3 shall comprise the following groups of signalling functions:

- Call Control (CC) management;
- Radio Resource (RR) management;
- Maintenance Resource (MR) management.

These functional groups shall be realized by separate protocol control entities.

### 10.2.2 Protocol architecture

The protocol architecture of layer 3 shall be divided into two sub-layers (see figure 38):

- the RR sub-layer shall provide services to the CC sub-layer and utilizes the service of signalling layer 2;
- the Connection Management (CM) sub-layer shall provide services of layer 3 and utilizes the service of the RR sub-layer.



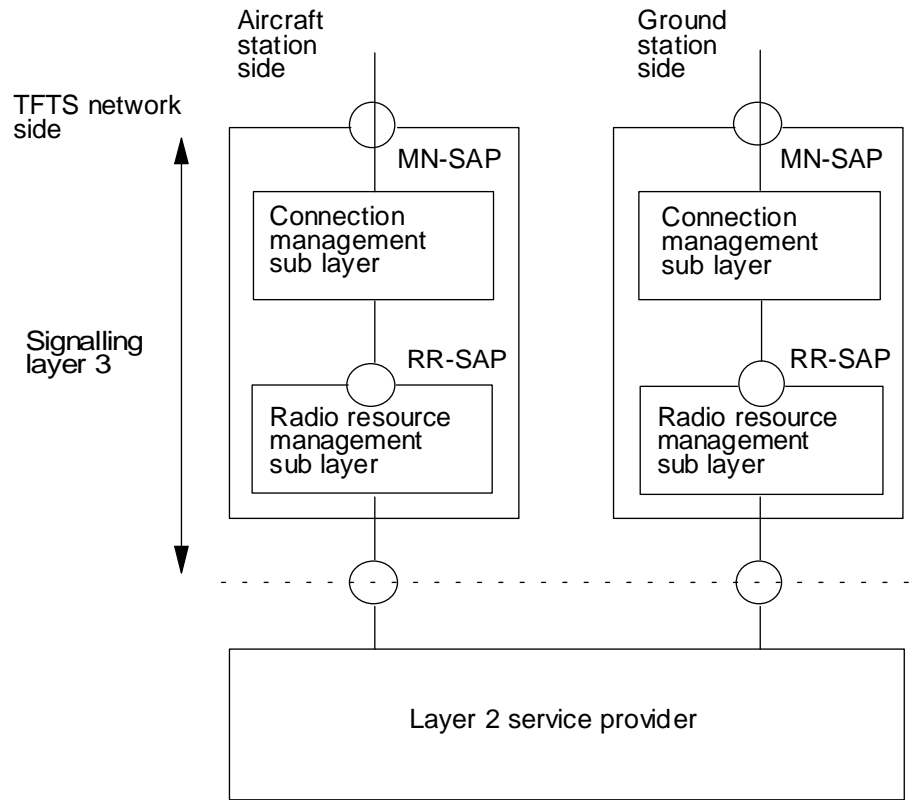


Figure 38: Protocol Architecture of signalling Layer 3

The CM sub-layer shall consist of parallel CC entities and MR entities (see figure 39).

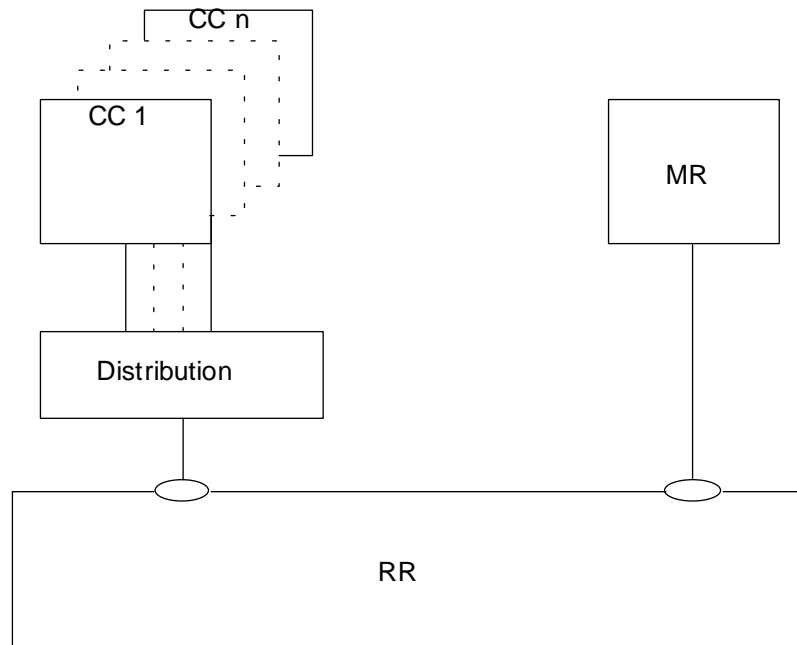


Figure 39: Parallel CC transactions on the CM sub-layer

### **10.3 Services provided by signalling layer 3 on the AS side**

#### **10.3.1 CC services**

##### **10.3.1.1 General**

The CC services shall be provided at the service access point Mobile Network - SAP (MN-SAP). The CC service class consists of the following services:

- aircraft originated call establishment;
- call maintaining;
- call clearing.

10.3.1.2 Service state diagram

The CC services provided at the MN-SAP are illustrated in the state diagram of figure 40.

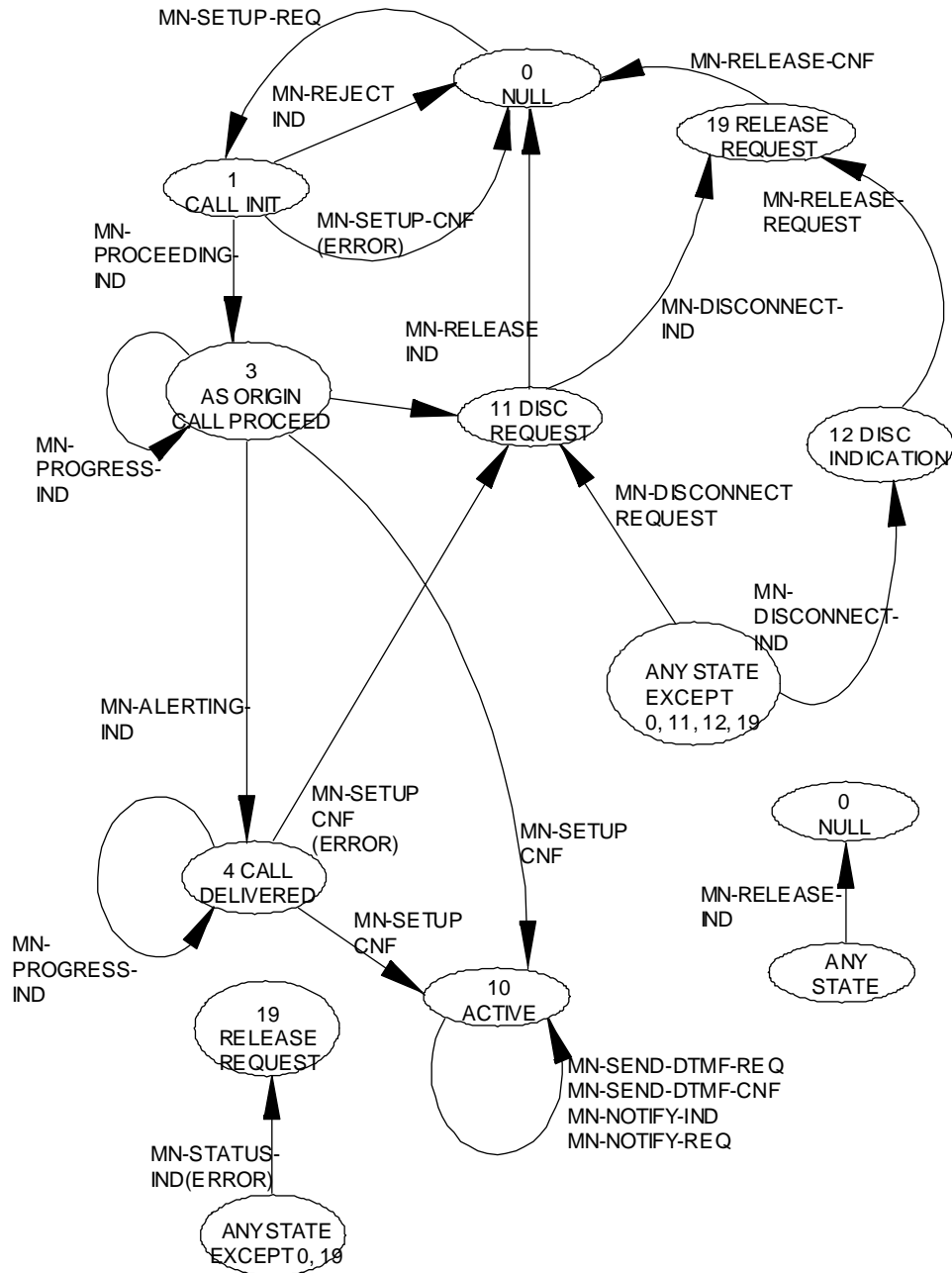


Figure 40: Service state diagram of CC entity on the AS-side

10.3.1.3 Service primitives

Primitives between MN and CC shall be as follows

**MN-SETUP-REQ:** A request to send a SETUP message to initiate aircraft originating establishment of a call.

**MN-SETUP-CNF:** A confirmation by receiving a CONNECT message that the aircraft originated call has been accepted by the remote called user. If the parameter "error" is present it shall indicate that the network or the called user is unable to accept the call.

**MN-REJECT-IND:** An indication to the aircraft originating user that the GSS is unable to accept the call.

**MN-PROCEEDING-IND:** An indication to the aircraft originating user that call establishment has been initiated in the network and no more call establishment information will be accepted.

**MN-PROGRESS-IND:** An indication to the aircraft originating user that a call is in progress in the event of interworking or in relation with the provision of inband information/patterns.

**MN-ALERTING-IND:** An indication to the aircraft originating user that remote called user alerting has been initiated.

**MN-DISCONNECT-REQ:** A request to send a DISCONNECT message to the GSS in order to clear the end-to-end connection.

**MN-DISCONNECT-IND:** An indication of the reception of a DISCONNECT message, by which the GSS indicates that the end-to-end connection is cleared.

**MN-RELEASE-REQ:** A request from the aircraft originating user to send a RELEASE message to inform the GSS that it intends to release its transaction identifier and the corresponding RR-connection so that the GSS can release its RR-connection and the correspondent transaction identifier.

**MN-RELEASE-IND:** An indication to the aircraft originating user that a RELEASE message has been received and the GSS intends to release its RR-connection. The aircraft originating user is requested to release its transaction identifier and the corresponding RR-connection.

**MN-RELEASE-CNF:** A confirmation of the aircraft user's request to release the RR-connection and transaction identifier in the GSS. The AS may release its transaction identifier and the corresponding RR-connection.

**MN-NOTIFY-REQ:** A request to send information appertaining to a call to the GSS.

**MN-NOTIFY-IND:** An indication to the aircraft originating user that information pertaining to a call, such as remote user suspended, has been received from the GSS.

**MN-STATUS-IND:** This primitive contains the parameter "error" and shall be used when the peer entity has indicated an incompatible state in a STATUS message.

**MN-SEND-DTMF-REQ:** A request to send a DTMF digit to the GSS.

**MN-SEND-DTMF-CNF:** A confirmation that a DTMF digit has been re-converted to a DTMF tone and applied towards the remote user. If the parameter "error" is present it shall indicate that the GSS can not accept the request to apply the DTMF tone towards the remote user.

## **10.4 Services provided by signalling layer 3 on the GSS side**

### **10.4.1 CC services**

#### **10.4.1.1 General**

The CC services are provided at the service access point MN-SAP.

The CC service class consists of the following services:

- call establishment;
- call maintaining;
- call clearing.

10.4.1.2 Service state diagram

The CC services provided at the MN-SAP are illustrated in the state diagram of figure 41.

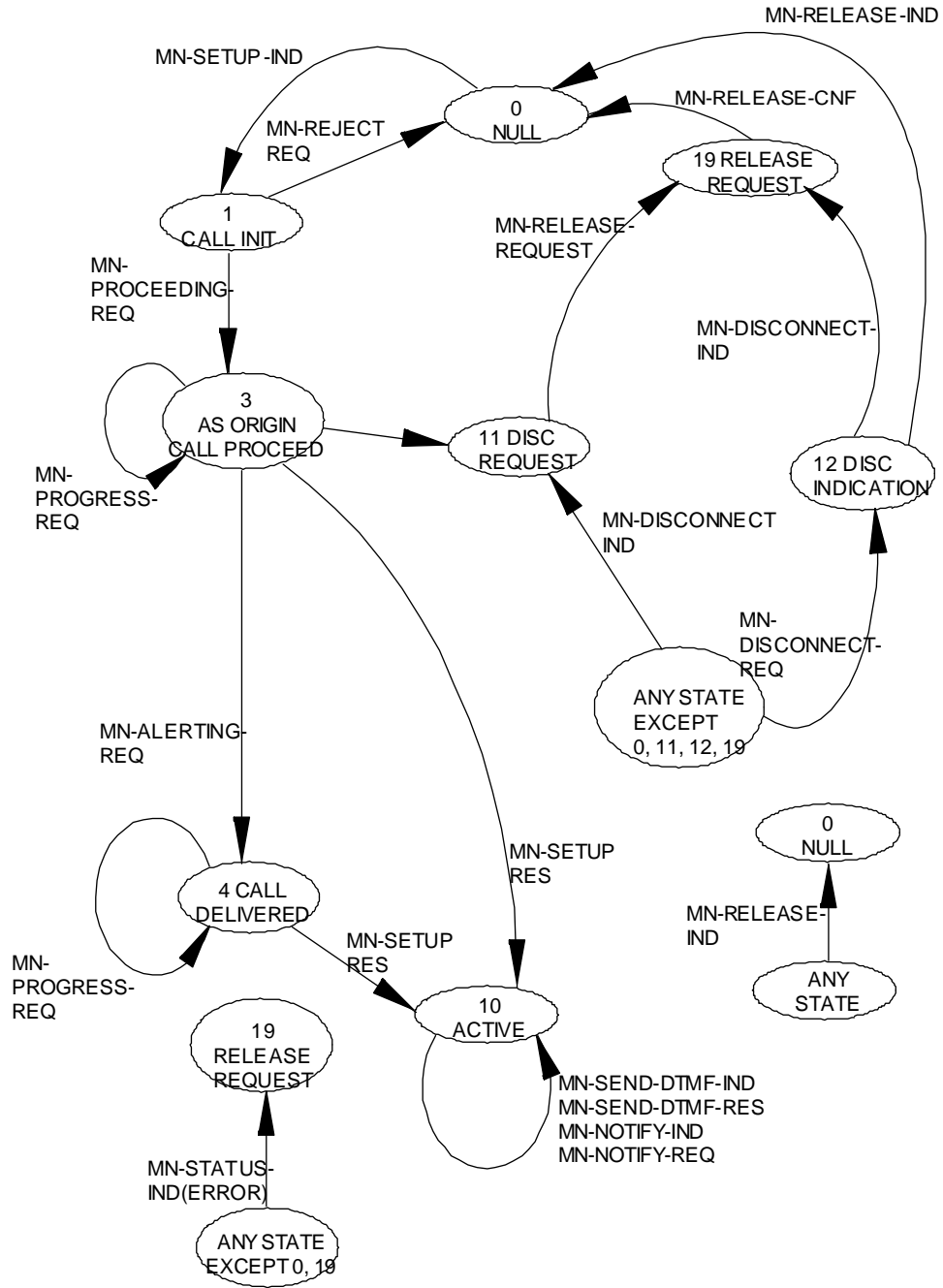


Figure 41: Service state diagram of CC entity on the GSS side

10.4.1.3 Service primitives

Primitives between MN and CC shall be as follows:

**MN-SETUP-IND:** An indication of reception of a SETUP message, the aircraft originating call establishment has been initiated.

**MN-SETUP-RES:** A response to a CONNECT message to indicate call acceptance by the remote user.

**MN-REJECT-REQ:** A rejection of the aircraft originated call establishment if the call cannot be accepted.

**MN-PROCEEDING-REQ:** A request to send a CALL PROCEEDING message to indicate to the aircraft originating user that call establishment has been initiated in the network and no more call establishment information can be accepted.

**MN-PROGRESS-REQ:** A request to send a PROGRESS message to indicate to the aircraft originating user that a call is in progress. This shall be used in the event of interworking or in relation with the provision of in-band information or signalling.

**MN-ALERTING-REQ:** A request to send an ALERTING message to indicate to the aircraft originating user that remote called user alerting has been initiated.

**MN-DISCONNECT-REQ:** A request to send a DISCONNECT message to the AS in order to clear the end-to-end connection.

**MN-DISCONNECT-IND:** An indication of reception of a DISCONNECT message, by which the AS shall indicate that the end-to-end connection is cleared.

**MN-RELEASE-REQ:** A request to send a RELEASE message to inform the AS that the GSS intends to release the RR-connection and the corresponding transaction identifier.

**MN-RELEASE-IND:** An indication of reception of a RELEASE message by which the AS shall indicate that it intends to release its RR-connection and transaction identifier.

**MN-RELEASE-CNF:** A confirmation that a RELEASE COMPLETE message has been received, the RR-connection in the AS has been released. The GSS shall release its RR-connection and the corresponding transaction identifier.

**MN-NOTIFY-REQ:** A request to send information appertaining to a call to the GSS.

**MN-NOTIFY-IND:** An indication to the aircraft originating user that information pertaining to a call, e.g. remote user suspended, has been received from the GSS.

**MN-STATUS-IND:** This primitive shall contain the parameter "error" and shall be used when the peer entity has indicated an incompatible state in a STATUS message.

**MN-SEND-DTMF-IND:** An indication that the aircraft originating user has made a request to apply a DTMF tone towards the remote user.

**MN-SEND-DTMF-RES:** This primitive indicates that the GSS has applied the indicated DTMF tone towards the remote user. If the parameter "error" is present it shall indicate that the GSS was not able to apply the DTMF tone towards the remote user.

## **10.5 Services assumed from signalling layer 2**

### **10.5.1 General**

The services provided by layer 2 are described in detail in clause 9.

### **10.5.2 Service primitives**

#### **10.5.2.1 Unacknowledged information transfer**

**DL-UNIT-DATA-REQ:** A request to send a message unit using the procedure for unacknowledged information transfer.

**DL-UNIT-DATA-IND:** An indication that the arrival of a message unit was received by means of unacknowledged information transfer.

### 10.5.2.2 Acknowledged information transfer

**DL-DATA-REQ:** A request to send a message unit using the procedures for multi-frame acknowledged information transfer.

**DL-DATA-IND:** An indication of the arrival of a message unit received by means of acknowledged information transfer.

**DL-ESTABLISH-REQ/IND/CNF:** These primitives shall be used for establishment of multiple frame operation between two (datalink layer entities) SAP.

**DL-SUSPEND-REQ/IND/CNF:** These primitives shall be used in the AS to request and confirm the release of multiple frame operation in a way that preserves any unacknowledged layer 3 message. It shall also be used to indicate that the data link layer is still in a suspended state after an unsuccessful establishment of multiple frame operation requested by a resume primitive. These primitives shall be used when changing of dedicated channels takes place.

**DL-RESUME-REQ/CNF:** A request and confirmation in the AS for establishment of multiple frame operation following a previous suspension without loss of layer 3 messages.

**DL-RELEASE-REQ/CNF/IND:** These primitives shall be used respectively to request, confirm and indicate an attempt to terminate multiple frame operation, between two SAP, or to make an attempt to perform local-end-release.

**MDL-RELEASE-REQ:** This primitive is used by RRM to request local end termination of a previously established acknowledged mode operation.

**MDL-ERROR-IND:** This primitive is used to notify RRM that an error has occurred as a result of communication with the data link peer entity which cannot be corrected by the data link layer.

## 10.6 Inter-layer service interfaces on the AS side

### 10.6.1 Services provided by the RRM entity

#### 10.6.1.1 General

The RRM sub-layer provides a service to the CM sub-layer (see figure 42).

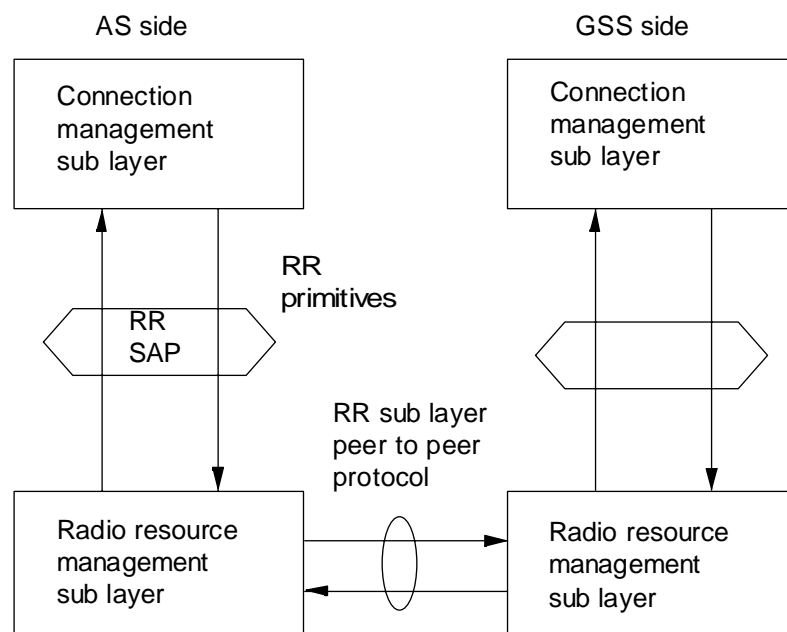


Figure 42: Service provided at RR-SAP/AS-side.

The RR service shall be used for:

- establishing control/traffic channel connections;
- maintaining control/traffic channel connections;
- releasing control/traffic channel connections;
- control data transfer.

The RRM service is represented by the RR-service primitives.

### 10.6.1.2 Service state diagram

The primitives provided by the RRM entity, and the transition between permitted states, are shown in figure 43 and figure 44.

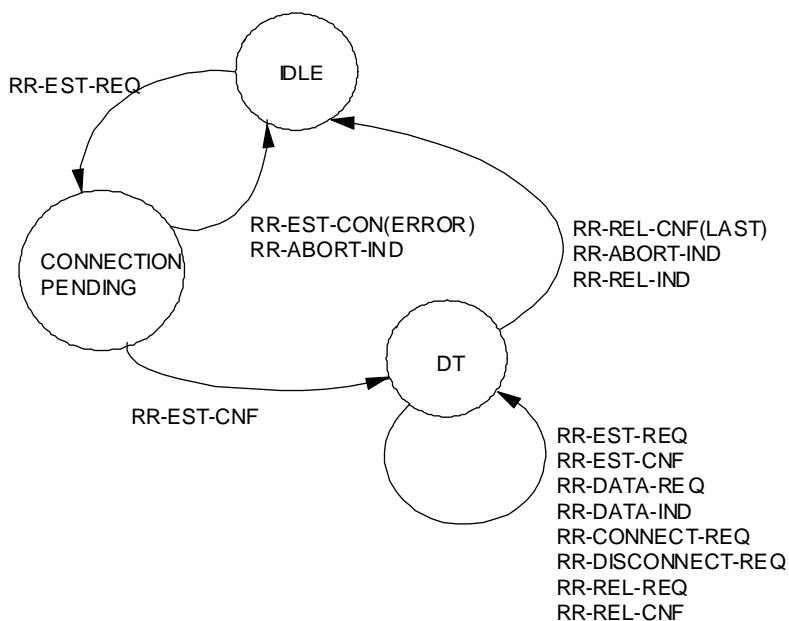


Figure 43: Service state diagram of RRM towards CC on the AS side



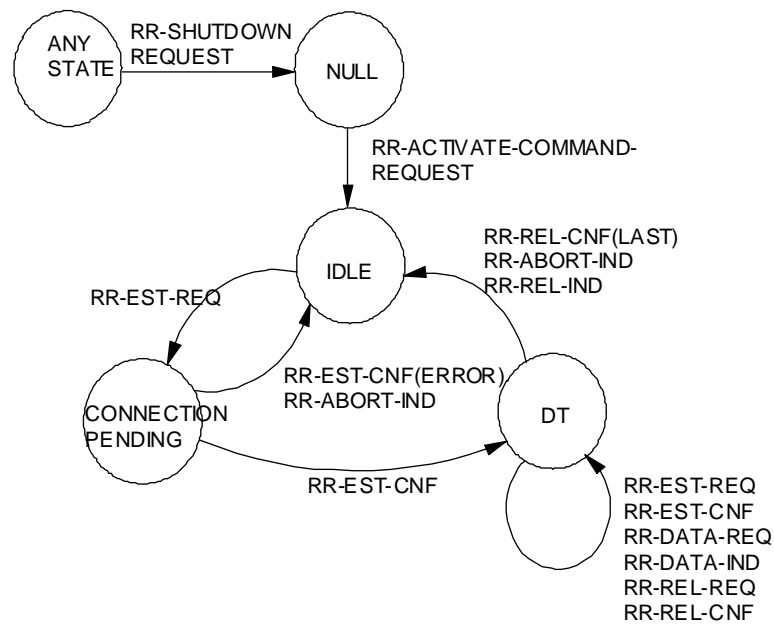


Figure 44: Service state diagram of RRM towards MR on the AS side

### 10.6.1.3 Service primitives

Primitives between RRM and CC shall be as follows:

**RR-EST-REQ:** A request used by the CC to request establishment of a aircraft originated RRconnection.

**RR-EST-CNF:** A confirmation used by RR to indicate the successful completion of a aircraft originated RR-connection establishment or the reason for the reject of the establishment.

**RR-REL-REQ:** A request used by the CC entity to release an RR-connection.

**RR-REL-CNF:** A confirmation that the RR-connection has been released.

**RR-REL-IND:** An indication that the resource allocated shall be released.

**RR-DATA-REQ:** A request used by the CC entity to send acknowledged control data to its peer entity on the GSS side via an existing RR-connection.

**RR-DATA-IND:** An indication used by RR to indicate, to the CC entity, control data which has been received from its peer entity on the GSS side via an existing RR-connection. The data shall have been acknowledged on layer 2.

**RR-ABORT-IND:** An indication that the RR-connection has been aborted by a lower layer failure.

**RR-CONNECT-REQ:** Used by CC to request the connection of the traffic channel.

**RR-DISCONNECT-REQ:** Used by CC to request the disconnection of the traffic channel.

Primitives between RR and the MR entity shall be as follows:

**RR-EST-REQ:** Used by the MR to request establishment of a aircraft originated RR-connection.

**RR-EST-CNF:** A confirmation used by RR to indicate the successful completion of an aircraft originated RR-connection establishment or the reason for the reject of the establishment.

**RR-REL-REQ:** Used to inform RR that the data transfer is completed.

**RR-REL-CNF:** A confirmation that the RR-connection has been released.

**RR-REL-IND:** An indication that the MR entity is not allowed to send data any longer.

**RR-ABORT-IND:** An indication that the RR-connection has been aborted by a lower layer failure.

**RR-DATA-REQ:** Used by the MR entity to send acknowledged data to its peer entity on the GSS side via an existing RR-connection.

**RR-DATA-IND:** An indication used by RR to indicate, to the MR entity, control data which has been received from its peer entity on the GSS side via an existing RR-connection. The data shall have been acknowledged on layer 2.

**RR-SHUTDOWN-COMMAND-REQ:** Used by the MR entity to abort all existing resources (if any) and to forbid the RRM to execute any request to establish new connections.

**RR-ACTIVATE-COMMAND-REQ:** Used to allow the RRM to establish new connections after a RR-Shutdown-Command.

**RR-SHUTDOWN-IND:** An indication to the MR entity that a shut-down message has been detected.

**RR-ENGPAGE-IND:** An indication to the MR entity that an engineering page message has been detected.

**RR-PAGE-IND:** An indication to the MR entity that a paging message has been detected.

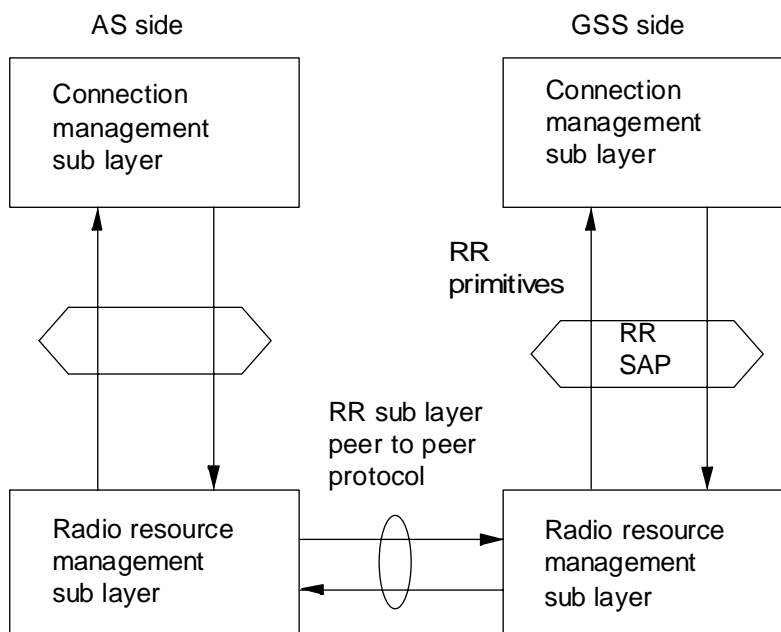
**RR-AVAILABLE-IND:** Indicates the availability of TFTS to the MR entity.

## 10.7 Inter-layer service interfaces on the GS side

### 10.7.1 Services provided by the RRM entity

#### 10.7.1.1 General

The RRM sub-layer provides a service to the CM sub-layer (see figure .45).



**Figure 45: Service provided at RR-SAP on the GSS side**

The RR service shall be used for:

- establishing control/traffic channel connections;
- maintaining control/traffic channel connections;
- releasing control/traffic channel connections;
- control data transfer.

The RRM services shall be represented by the RR-service primitives.

### 10.7.1.2 Service state diagram

The primitives provided by the RRM entity and the transition between permitted states are shown in figures 46 and 47.

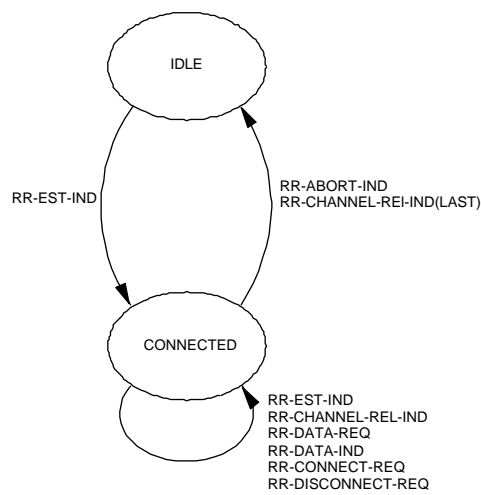
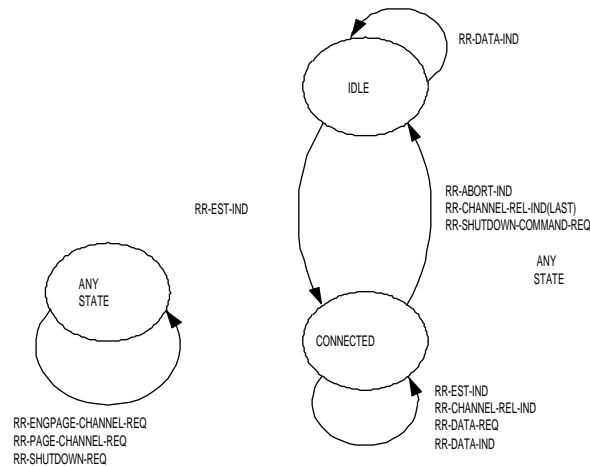


Figure 46: Service state diagram of RRM towards CC on the GSS side



**Figure 47: Service state diagram of RRM towards MR on the GSS side**

### 10.7.1.3 Service primitives

Primitives between RR and CC shall be as follows:

**RR-EST-IND:** An indication to the CC entity that an RR-connection is available on request by the peer entity.

**RR-CHANNEL-REL-IND:** Used to indicate that the resource allocated has been released.

**RR-DATA-REQ:** Used by the CC entity to send acknowledged control data to its peer entity on the aircraft side via an existing RR-connection.

**RR-DATA-IND:** Used by RR to indicate, to the CC entity, control data which has been received from its peer entity on the aircraft side via an existing RR-connection. The data shall have been acknowledged on layer 2.

**RR-ABORT-IND:** An indication that the RR-connection has been aborted by a lower layer failure.

**RR-CONNECT-REQ:** Used by CC to request the connection of the traffic channel.

**RR-DISCONNECT-REQ:** Used by CC to request the disconnection of the traffic channel.

Primitives between RR and the MR entity shall be as follows:

**RR-EST-IND:** An indication to the MR entity that an RR-connection is available.

**RR-CHANNEL-REL-IND:** Used to indicate that the resource allocated has been released.

**RR-ABORT-IND:** An indication that the RR-connection has been aborted by a lower layer failure.

**RR-DATA-REQ:** Used by the MR entity to send acknowledged control data to its peer entity on the aircraft side via an existing RR-connection.

**RR-DATA-IND:** An indication used by RR to indicate, to the MR entity, data which has been received from its peer entity on the aircraft side via an existing RR-connection. The data shall have been acknowledged on layer 2.

**RR-ENGAGE-CHANNEL-REQ:** A request by the MR entity to send a message for engineering paging purposes.

**RR-PAGE-CHANNEL-REQ:** A request by the MR entity to send a message for paging purposes.

**RR-SHUTDOWN-REQ:** A request by the MR entity to send a message for shutdown purposes.

**RR-SHUTDOWN-COMMAND-REQ:** A request by the MR entity to abort all allocated resources.

## 10.8 Service assumed from layer 1

### 10.8.1 General

The services provided by layer 1 are described in detail in subclause 5.3.

### 10.8.2 Service primitives

The following primitives are defined between layer 1 and RRM entity of layer 3:

**MPH-INFORMATION:** Used to control measurement activities of the physical layer by the RRM entity. They transfer measurement results from layer 1 to RRM and measurement control information from RRM to layer 1.

**MPH-CONFIGURE:** Used for the control of the physical layer by the RRM entity. These primitives activate and de-activate, configure and de-configure, through connect and disconnect physical and logical channels.

**MPH-RANDOM-ACCESS:** Used to control the cold start access of an AS to a radio channel. In the AS they request initiation and confirm completion of the random access transaction. In the GS they indicate the request of an AS for the negotiation slot.

**MPH-CHANNEL-ACCESS:** Used to control a procedure to synchronize the GS for reception of transmissions from the AS, and mainly used during handover. In the AS they request initiation and confirm completion of the channel access transaction. On the GS they indicate the reception of an entry slot and synchronization of the GS to transmissions from the AS.

## 10.9 Functions provided by layer 3 entities

### 10.9.1 Functions provided by the RRM entity

The RRM entity contains elementary procedures for radio management e.g. establishing, maintaining and release of physical channels. This includes handover (i.e. cell change). The support of parallel CC entities is another task for which it contains elementary procedures.

The elementary procedures in the RR-sub-layer are specified in subclause 10.11.

### 10.9.2 Functions provided by the CC management entity

The CC management entity contains elementary procedures to support establishing, maintaining and clearing of aircraft originating circuit-switched calls.

The elementary procedures in the CC entity are specified in subclause 10.11.

### 10.9.3 Functions provided by the distribution entity

The function of the distribution entity shall be as follows:

- to receive messages from RR and distribute them to the addressed CC entity. A CC entity is addressed by its Transaction Identifier (TI);
- to multiplex messages from different CC entities to the RR-connection.

10.9.4 Functions provided by the MR entity

The function of the MR entity is to support engineering paging, paging and the transfer of Operation and Maintenance (OM) data. It shall also support the shut-down procedure of an AS.

10.10 Call setup examples

This subclause is provided for information purposes only. In arrow diagrams examples of call setup for first call and subsequent call are shown.

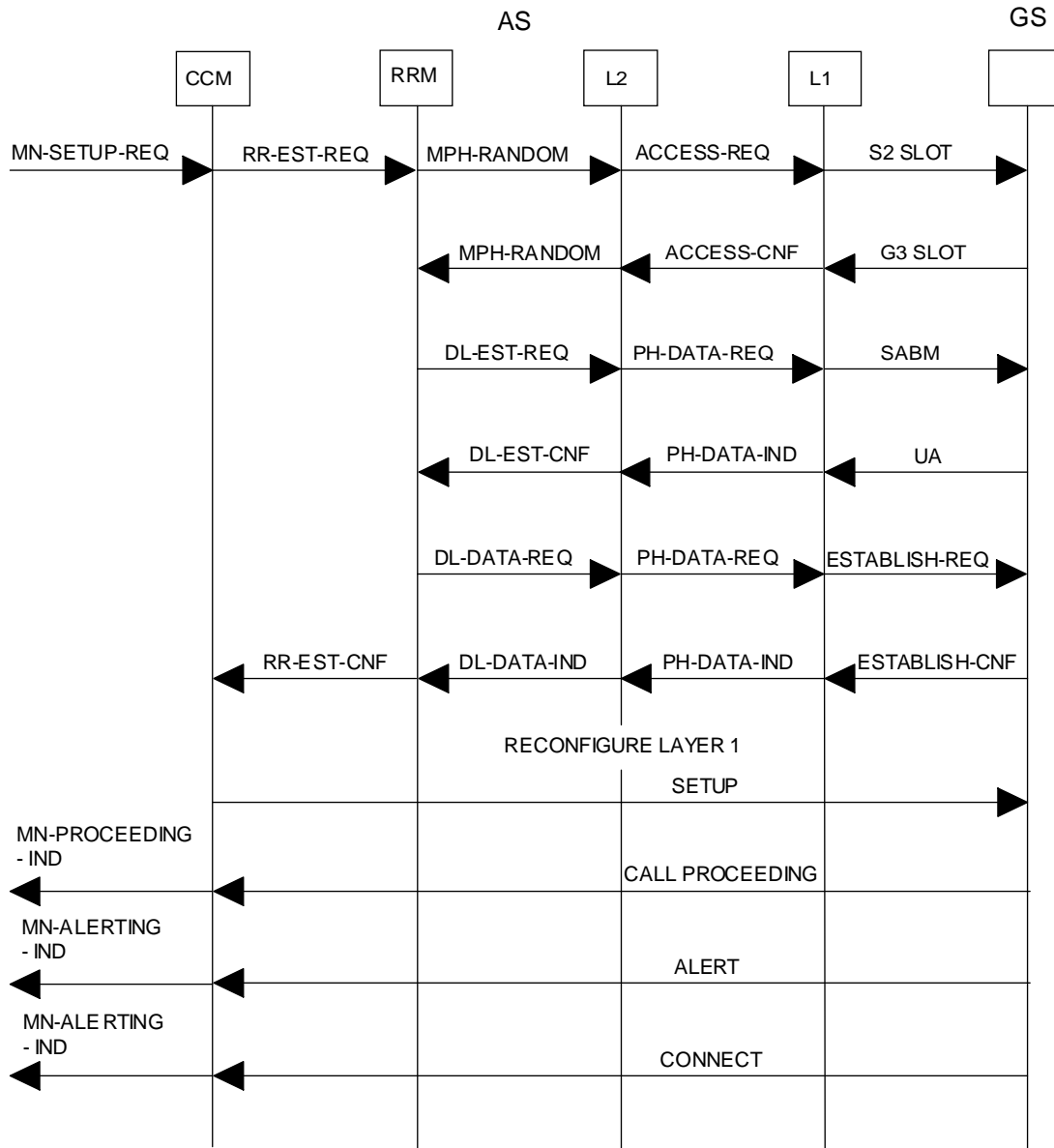


Figure 48: TFTS call setup - first call

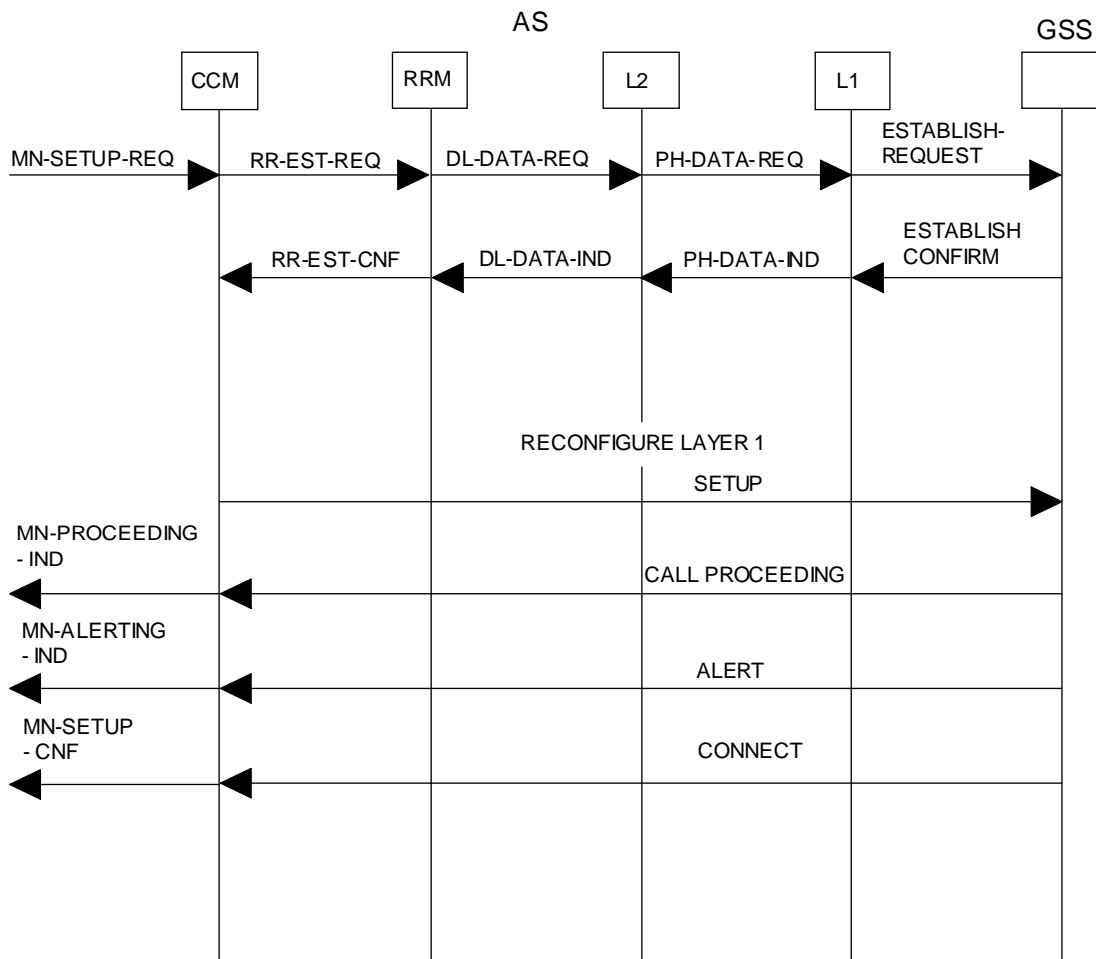


Figure 49: TFTS call setup - subsequent call

## 10.11 Radio interface layer 3 specification

### 10.11.1 General

This subclause specifies the procedures used at the radio interface for CC, RRM and MM.

These procedures are defined in terms of messages exchanged over the control channels of the radio interface. The control channels are described in clause 7.

The structured functions and procedures of this protocol and the relationship with other layers and entities are described in general terms in clause 9.

#### 10.11.1.1 Scope of the specification

The procedures described in this subclause are for the CC of circuit-switched connections, RRM and Maintenance Resource Management (MRM).

#### 10.11.1.2 Application to the interface structure

The layer 3 procedures apply to the interface structures defined in clause 7. They use the functions and services provided by layer 2 defined in clause 9.

NOTE: The term "layer 3" is used for the functions and protocol described in this clause of this ETS. The terms "data link layer" and "layer 2" are used interchangeably to refer to the layer immediately below layer 3.

### 10.11.1.3 Structure of the layer 3 procedures

A building block method is used to describe the layer 3 procedures. The basic building blocks are "elementary procedures" provided by the protocol control entities of the two sub-layers, RRM sub-layer and CM sub-layer.

Complete layer 3 transactions consist of specific sequences of elementary procedures.

### 10.11.1.4 Test procedures

Test procedures of the radio interface signalling is described in the TETS Conformance Test Standard.

### 10.11.1.5 Use of logical channels

The logical control channels are defined in clause 7.

## 10.11.2 Overview of control procedures

### 10.11.2.1 List of procedures

The following procedures are specified in this specification:

- 1) subclause 10.11.3 specifies elementary procedures for RRM:
  - system information broadcasting;
  - radio resources connection establishment;
  - radio resources connection transfer phase;
  - radio resources connection release.
- 2) subclause 10.11.4 specifies elementary procedures for circuit switched CC:
  - aircraft originating call establishment;
  - signalling procedures during the active state;
  - DTMF protocol control procedure;
  - user notification procedure;
  - call rearrangement;
  - call clearing initiated by the AS;
  - call clearing initiated by the GSS;
  - miscellaneous procedures;
  - in-band tones and announcement;
  - status procedure.
- 3) subclause 10.11.5 specifies elementary procedures for MRM:
  - paging;
  - engineering paging;
  - shutdown;
  - operations and maintenance data transfer.

The elementary procedures are combined to form structured procedures.

### 10.11.2.2 Procedure for contention resolution

Upon seizure of the assigned dedicated channel, the AS shall establish the signalling link on the channel by sending a layer 2 frame containing a layer 3 message. The data link layer shall store the message and shall perform the contention resolution. The layer 3 message shall be returned by the GSS in a layer 2 frame.



The data link layer in the AS shall compare the content of the information field (i.e. the layer 3 message) received in the layer 2 frame with the stored message, and shall leave the channel in the idle state when they do not match.

NOTE: This procedure resolves contention in the case where several aircraft stations have accessed with RACH in the same slot and with the same random number entry identity. The full description of the procedure is given in clause 9.

The layer 3 message shall contain the identity of the AS and the initial transmit power.

### **10.11.2.3 General recovery procedures**

#### **10.11.2.3.1 Normal message flow**

Essential request messages sent by a CC entity shall be acknowledged by the peer entity and supervised by a timer T, in the requesting side. T is described for each procedure in this ETS. Upon receiving a request message, the answering side shall reply to the request, even if it has already acknowledged it before.

The request timer value shall be chosen such that possible channel changes will not affect the timer expiry.

#### **10.11.2.3.2 Expiry of the request timer T**

The request timer T shall be set upon sending the request message. It shall be reset at the receipt of the reply message or at the release of the transaction.

NOTE: Since layer 2 provides a data link layer service protection against frame loss, the request timer cannot expire because of a message loss on the radio interface. It may expire due to sporadic procedural errors in transitory states.

The action to be taken at timer expiry is described for each procedure in this specification.

#### **10.11.2.3.3 Change of dedicated channels using SAPI=0**

If a change of dedicated channels should be required using a handover procedure, the RR-sub-layer shall request the data link layer to suspend multiple frame operation before the AS leaves the old channel. When the channel change has been completed, layer 3 shall request the data link layer to resume multiple frame operation. The layer 2 suspend/resume procedures are described in clause 9.

These procedures are specified such that a loss of layer 3 message shall not occur on the radio interface. However CM-messages sent from the AS to the GSS may be duplicated by the data link layer if a message has been transmitted but not yet completely acknowledged before the AS leaves the old channel.

NOTE: As RR is controlling the channel change, a duplication of RR-messages does not occur. However, there are some procedures for which a duplication is possible, e.g. DTMF procedures. For all CM-procedures, the request messages sent by the AS contain a sequence number in order to allow the GSS to detect duplicated messages, which are ignored by the GSS.

The procedures for sequenced transmission on layer 3 are described in subclause 10.11.2.4.

### **10.11.2.4 Sequenced message transfer operation**

CM-messages sent from the AS to the GSS may be duplicated by the data link layer in the following case:

- a channel change of dedicated channels is required (handover), and there are outstanding layer 2 frames that have not been acknowledged by the peer data link layer, before the AS leaves the old channel.

In this case, the AS does not know whether the GSS has received the messages correctly, and therefore the AS shall send the messages again after the new dedicated channel has been established (see clause 9).

The GSS shall detect the duplicated received messages, by examining the send sequence number of each CM-message received.

#### **10.11.2.4.1 Variables and sequence numbers**

##### **10.11.2.4.1.1 Send state variable V(SD)**

Each entity in the CM-sub-layer (i.e. each CC entity and the MR entity) shall have its own associated V(SD) ("Send Duplicated") for sending CM-messages. The V(SD) shall denote the sequence number of the next in-sequence CM-message to be transmitted. The value of the V(SD) shall be incremented once with each CM-message transmission. The value shall be incremented by modulus 4.

##### **10.11.2.4.1.2 Send sequence number N(SD)**

Only CM-messages shall contain the N(SD). At the time when a CM-message is designated for transmission, the value of N(SD) for the message to be transferred shall be set equal to the value of the V(SD).

#### **10.11.2.4.2 Procedure for the setting, transfer and termination of sequenced message transfer**

##### **10.11.2.4.2.1 Setting**

The sequenced message transfer operation shall be set when requested RR are established. The V(SD) shall be set to 0.

##### **10.11.2.4.2.2 Transfer**

The receiving peer entities in the GSS shall ensure that received messages are in-sequence. If a received message is out of sequence, and the message has already been received, it shall be discarded.

##### **10.11.2.4.2.3 Termination**

The sequenced message transfer operation shall be terminated by a request of release of RR.

#### **10.11.3 Elementary procedures for RRM**

##### **10.11.3.1 Overview**

###### **10.11.3.1.1 General**

RRM procedures include the functions related to the management of the common transmission resources, e.g. the physical channels and the data link connections on control channels.

The general purpose of RR procedures is to establish, maintain and release RR-connections that allow a point-to-point dialogue between the GSS and an AS. This includes the cell selection/reselection and the handover procedures. Moreover, RRM procedures include the establishment and maintaining of the one way reception of the BCCH.

In addition a mechanism for the transmission of operation and maintenance data is offered by the RRM.

### **10.11.3.1.2 Service provided to upper layers**

#### **10.11.3.1.2.1 The null state**

When the RRM is in the null state no service shall be offered to the upper layers.

If the RRM is in the idle mode, or any other state, and an RR-SHUTDOWN-COMMAND-REQUEST primitive is sent from the maintenance management sub-layer the RR management sub-layer shall release the existing resources and shall enter the null state.

If the MR sub-layer activates an RR-ACTIVE-COMMAND-REQUEST primitive or if a manual reset of the TFTS equipment is carried out the RRM shall enter the idle mode.

#### **10.11.3.1.2.2 Services provided in idle mode**

The RR procedures in idle mode shall include the continuously active scanning process that tracks the available cells. The RR entity shall indicate to the CM sublayer the availability of a BCCH and of suitable cells. Upper layers may then request the establishment of a physical radio channel.

#### **10.11.3.1.2.3 Establishment and release of an RR-connection**

An RR-connection shall include the following:

- a physical point-to-point bidirectional connection;
- an established DCCH; and
- zero, one or several TCH; or
- one or several signaling resources.

The radio resource provided for the RR connection may vary in time.

If upper layers request the provision of radio resources for a traffic data or signaling connection, RRM shall establish a physical RR connection (if no previous connection exists) and assign the required resources.

Conversely, if upper layers inform RRM that a TCH or signaling connection is no longer needed, RRM shall release the resources providing that there are no data to transmit by the OM.

See also subclause 10.11.5.2.5.

#### **10.11.3.1.2.4 Service provided in RR connected mode**

The RR procedures in RR connected mode are defined below:

- transfer of message on a data link connection;
- indication of loss of RR connection;
- handover to maintain the RR connection;
- allocation and release of further resources.

#### **10.11.3.1.3 Service required from data link and physical layers**

The RR sub-layer shall utilise the services provided by the data link layer as defined in clause 9.

The RR sub-layer shall directly use services provided by the physical layer, e.g. channel set-up and measurement reports.

#### 10.11.3.1.4 Terminology

**null mode:** In this mode the AS shall not allocate any resources;

**idle mode:** In this mode the AS shall not allocate any dedicated channels;

**RR connected mode:** In this mode, the AS shall be allocated a dedicated channel used either as a DCCH or as a DCCH and a TCH;

**activated channel:** A channel shall be activated if it can be used for transmission of signalling;

**TCH connected:** A TCH shall be connected if circuit mode user data can be transmitted. A TCH shall not be connected if it is not activated.

NOTE: A TCH which is activated, but not connected, is used only for signalling as a part of a DCCH;

**DCCH connected:** a DCCH shall be allocated to an AS when it is in the RR-connected mode.

#### 10.11.3.2 System management procedures

Each GS transmits a set of system information data on one radio channel (see subclause 8.10), the BCCH. The BCCH information shall be used by the AS for cell selection during initial call set-up and in connected mode for decision on handover.

##### 10.11.3.2.1 BCCH (D) data acquisition (AS side)

The AS shall continuously scan the BCCH (D) information of neighbouring cells indicated by a set of primary frequencies (see subclause 8.10). The AS periodically shall acquire a complete set of BCCH (D) data for each of the neighbouring cells.

The detailed requirements for this BCCH (D) data acquisition procedure and the usage of the BCCH (D) data in the AS decision process are described in subclause 8.10.

NOTE: There are 8 different types of SYSTEM INFORMATION messages associated with the BCCH (D) (see subclause 10.11.3.2.3).

##### 10.11.3.2.2 Other system data acquisition (AS side)

Additional range information and measurement results on channel quality, e.g. BER and signal strength, shall also be stored by the RRM.

The BCCH (D) data shall be used to:

- decide in the AS if a handover is required;
- select a GS and a radio channel (cell selection);
- detect a paging request;
- detect a request for immediate close-down of transmissions;
- detect an engineering paging request.

### 10.11.3.2.3 Broadcast system information (GS side)

The SYSTEM INFORMATION TYPES 1..9 messages shall be broadcast in a fixed cycle of 5 frames.

The sequence shall be SYSTEM INFORMATION 1, SYSTEM INFORMATION 2..4, and then SYSTEM INFORMATION 5, or SYSTEM INFORMATION 6, or SYSTEM INFORMATION 7, or SYSTEM INFORMATION 8.

Determination of which of SYSTEM INFORMATION 5 to 8 is sent on the fifth frame of the cycle shall be controlled by the GSS.

The information broadcast shall be grouped in the following classes:

- a) SYSTEM INFORMATION 1:
  - time information to ensure commonality of time stamps;
  - logical and geographical identification of the GS;
- b) SYSTEM INFORMATION 2:
  - cell management parameters;
- c) SYSTEM INFORMATION 3:
  - description of the en-route primary frequencies;
- d) SYSTEM INFORMATION 4:
  - description of the en-route primary frequencies (continued from SYSTEM INFORMATION 3); and
  - description of the INT and AP primary frequencies;
- e) SYSTEM INFORMATION 5:
  - command a immediate close-down to a selected AS;
- f) SYSTEM INFORMATION 6:
  - used for paging purposes;
- g) SYSTEM INFORMATION 7:
  - used for engineering paging purposes;
- h)- SYSTEM INFORMATION 8:
  - a dummy field with all bits set to 0 sent if no SYSTEM INFORMATION 5, 6 or 7 needs to be sent;
- i) SYSTEM INFORMATION 9:
  - used for group broadcast (see subclause 10.11.3.3.3);
- j) SYSTEM INFORMATION 20 (OPTIONAL):
  - used for test purposes. This information replaces SYSTEM INFORMATION 3 when a GS is in use for testing. In this case the GS will not receive normal traffic.

### **10.11.3.3 Paging procedures**

#### **10.11.3.3.1 Paging of a subscriber**

To page a subscriber the PAGE procedure allows an operator to request a data connection to an AS for sending specific paging messages to an AS.

##### **10.11.3.3.1.1 Initiation of the PAGE**

The PAGE procedure shall be initiated from the GSS. The MR entity in the GS shall request RRM to place an PAGE message in the BCCH (D).

##### **10.11.3.3.1.2 Broadcast duration for paging**

The broadcast duration of the page message shall be controlled by the counter CT3100 which counts the number of re-transmissions on the BCCH(D).

If the maximum number of N3100 retransmissions is reached, the page message shall be deleted from the BCCH(D).

##### **10.11.3.3.1.3 PAGE response**

When an AS receives the PAGE request message it shall be passed to the MR entity.

The MR entity shall check if it is the AS which is identified in the PAGE request message. If so, the MR entity shall request a data connection from RRM. This shall be initiated by the initial assignment procedure if no connection exists and by an additional assignment if a connection exists.

As no TCH shall exist for a PAGE request message the allocated slot(s) shall be a FACCH.

##### **10.11.3.3.1.4 Release of the connection**

The release of the connection may be initiated by the AS or by the GSS. The release message shall be passed to the AS which shall request RRM to release the allocated slots using the release procedure described in subclause 10.11.3.5.4.

##### **10.11.3.3.1.5 Abnormal cases**

A lower layer failure and a ground network failure shall be handled as described in subclauses 10.11.3.7.2 and 10.11.3.7.3.

#### **10.11.3.3.2 Engineering paging (ENGPAGE)**

ENGPAGE shall allow an operator to request a data connection to the AS and receive reports from the AS (for example to support testing of software in the AS).

##### **10.11.3.3.2.1 Initiation of the ENGPAGE**

The ENGPAGE procedure shall be initiated from the GSS. The MR entity in the GS shall request RRM to place an ENGPAGE message in the BCCH (D).

##### **10.11.3.3.2.2 Broadcast duration for ENGPAGE**

The broadcast duration of the ENGPAGE message shall be controlled by the counter CT3101 which counts the number of re-transmissions on the BCCH(D).

If the maximum number of N3101 retransmissions is reached the ENGPAGE message shall be deleted from the BCCH(D).

#### **10.11.3.3.2.3      ENGPAGE response**

When an AS receives the ENGPAGE request message it shall be passed to the MR entity. The MR entity shall check if it is the AS which is identified in the ENGPAGE. If so, MR entity shall request a data connection from RRM. The connection shall be initiated by the initial assignment procedure if no connection exists and by an additional assignment if a connection exists.

As no TCH shall exist for a ENGPAGE request message the allocated slot(s) shall be a FACCH.

#### **10.11.3.3.2.4      Release of the connection**

The release of the connection may be initiated by the AS or by the GSS. The release message shall be passed to the AS which shall request RRM to release the allocated slots using the release procedure described in subclause 10.11.3.5.4.

#### **10.11.3.3.2.5      Abnormal cases**

A lower layer failure and a ground network failure shall be as described in subclauses 10.11.3.7.2 and 10.11.3.7.3.

#### **10.11.3.3.3      Group broadcast**

The group broadcast facility is used to send short alphanumeric messages to aircraft.

##### **10.11.3.3.3.1      Network functionality**

When there is group broadcast information to be sent, the network shall assemble a SYSTEM INFORMATION TYPE 9 message containing a reference to the timeslot (on the access carrier) in which the group broadcast data will be transmitted, an indication of the length of the group broadcast data and a reference indicating the aircraft group to which the group broadcast data is addressed. This shall be transmitted on the BCCH(D) according to the rules given in subclause 10.11.3.2.3.

The network shall transmit the group broadcast data in the timeslot indicated in the SYSTEM INFORMATION TYPE 9 message using the GROUP BROADCAST DATA TRANSFER message of subclause 10.11.7.1.13a. The data shall be transmitted in unacknowledged mode.

If there is no group broadcast data to be transmitted this shall be indicated by setting the slot allocation element value to zero.

##### **10.11.3.3.3.2      AS functionality**

The AS shall monitor and decode the SYSTEM INFORMATION TYPE 9 message and when the aircraft group information element contains a value which includes the AS it shall additionally monitor and decode the contents of the timeslot indicated in the SYSTEM INFORMATION TYPE 9 message.

##### **10.11.3.3.3.3      Broadcast data repeat length**

The repeat length of the group broadcast data transfer message should be decided by the system operator.

#### **10.11.3.4      RR connection establishment initiated by the AS**

##### **10.11.3.4.1      Request for resources by the AS**

In idle mode the AS may initiate the establishment of a RR connection by using the initial assignment procedure which is initiated on the request by CC or MR for A radio resource.

The initial assignment procedure shall be used to immediately transfer an AS requiring service by a random access procedure to a dedicated channel, DCCH.

The initial assignment procedure shall contain:

- the activation of a physical channel;
- the establishment of a data link connection.

The initial assignment procedure shall be exclusively initiated by the AS. RRM shall start the initial assignment procedure by commanding to layer 1 a random access transaction to the access channel indicated by the BCCH(s). This transaction shall be used by layer 1 to demand, from the GS, access to the negotiation slot indicated as part of the BCCH(S) for use as a DCCH. Details of the random access transaction and the indication of the negotiation slot by the GS are described in subclause 8.10. Layer 1 shall indicate to RRM the success or failure of the random access transaction.

The request for the negotiation slot may be repeated if it fails. The counter CT3000 indicates the number of attempts on different frequencies or GSs.

If the GS grants access to the negotiation slot, RRM shall issue to layer 2 a DL-ESTABLISH-REQUEST primitive to set up the data link on the DCCH. As a parameter to this primitive RRM shall pass the IDENTITY INDICATION to layer 2. Layer 2 shall then use the contention resolution procedure described in clause 9 to establish the data links. This procedure shall pass the IDENTITY INDICATION to the GSS where it is used to identify the AS to the GSS to check its right to access the system. A second parameter is the initial transmit power.

If the establishment of the data link is confirmed by layer 2 in the DL-Establish-Confirm primitive, the initial assignment procedure is complete and the negotiation process shall commence (see subclause 10.11.3.4.3).

#### **10.11.3.4.2 Answer from the GS**

Layer 1 in the GS shall continuously test the offered access channel for reception of a random access message.

If the reception of a random access message is indicated by layer 1 (by an MPH-RA-Indication primitive) RRM shall first select a new negotiation slot and a new access channel for layer 1. The timing requirements for procedure are described in subclause 5.5.

RRM shall wait for the establishment of the data link on the negotiation channel. The timer T3101 shall control the time until the data link is established. The DL-Establish-Indication primitive shall include the IDENTITY INDICATION parameter. The Aircraft Termination Equipment Identifier (ATEI) contained in this parameter shall be transferred to the GSC for validation purposes.

#### **10.11.3.4.3 Negotiation process**

After the data link is established by the initial assignment procedure, the AS shall commence the negotiation process on a DCCH by sending an ESTABLISH-REQUEST message which describes the required resources (e.g. full rate, half rate or quarter rate channel for speech or 9,6 kbit/s, 4,8 kbit/s or 2,4 kbit/s for signalling, data and layer 1 coding requirements) and shall wait in the Data Transfer (DT) mode for the answer of the GSS.

If the required resources are available on the radio link (this may be on a radio channel different from that used for negotiation) and in the GSS, the GS shall send an ESTABLISH-CONFIRM message to the AS. This message shall indicate the frequency of the radio channel and the slots allocated to the requested resource. If a handover occurs during the negotiation process the signalling shall be stopped and restarted again after the handover is completed.

The GS shall also update the BCCH(D) data to reflect the modified resources available at the GS. If necessary this may include a re-allocation of the BCCH(D) to another slot or frequency.



#### **10.11.3.4.4 Assignment completion**

If the negotiation process has been successful the assignment process shall be completed in the AS by switching the physical layer to the new allocated resources. CC or MR shall be informed of the established channel by an RR-ESTABLISH-CONFIRM primitive.

On the GS side the assignment shall be complete when the response to the request is sent to the AS (see also subclause 10.11.3.4.3) and the RRM switches the physical layer to the assigned resources.

#### **10.11.3.4.5 Abnormal cases**

If an assignment request is rejected by the GS an ESTABLISH-REJECT message with the appropriate cause value shall be sent on the DCCH. CC or MR in the AS shall be informed, by a RR-Establish-Confirm (ERROR) primitive, that the establishment of the traffic channel has failed. The cause of the rejection shall be indicated.

RRM shall disconnect the data link and shall return to the Idle mode.

NOTE: This action may be because no resources are available or the requested service is not supported, or the AS identified by its ATEI, is not allowed to enter the TFTS.

If a lower layer failure occurs on the AS before the successful establishment of the signalling link, the AS shall attempt to establish the connection on another GS (see subclause 8.10). If the maximum number of  $N3000 = 2$  (two attempts) is exceeded, an RR-Establish-confirm (ERROR) primitive shall be sent to the CC or MR and the RRM shall return to IDLE mode. The ERROR message shall indicate the cause of the failure.

If no data link is established (e.g. the response on the random access is lost on the radio path), the timer T3101 shall expire and the allocated negotiation slot shall be released.

A lower layer failure and a ground network failure shall be handled as described in subclauses 10.11.3.7.2 and 10.11.3.7.3.

#### **10.11.3.4.6 Remap Procedure for radio resource establishment**

When the GS receives an ESTABLISH REQUEST from the AS it allocates radio resources. The GS shall prepare its layer 1 by using the remap procedure. If the remap initialisation is successful the GS RRM shall transmit an ESTABLISH CONFIRM to the AS with a list of time slots. The AS shall then prepare its layer 1 using the remap procedure. If the AS remap procedure is successful the RRM entities at both sides shall receive a positive remap confirm (or indication) from layer 1.

At the AS RRM shall inform the upper layers that the resource is established. A remap failure shall be handled as described in subclause 10.11.3.7.4.

#### **10.11.3.5 RR-connection transfer phase**

##### **10.11.3.5.1 Transfer of messages**

When a RR-connection is established, upper layers may send messages in multi-frame or unacknowledged mode on SAPI 0.

##### **10.11.3.5.2 Handover procedure**

The purpose of the handover procedure is to completely modify the channels allocated to the AS e.g. when the cell is changed or for balancing purposes. This procedure shall be used in the DT mode (AS) or RR-CONNECTED mode (GS).

The handover procedure shall include:

- the suspension of the signalling link;

- the activation of the new physical channels and their connection;
- the establishment of data link connection for SAPI = 0 on the new channels.

A handover procedure may be initiated either by the AS or by the GS. Handover initiated by the GS shall be used for traffic balancing purposes and shall change the radio channel and/or slot allocation at the same GS (intra-cell handover).

#### 10.11.3.5.2.1 Handover procedures on GS side

A request for handover to the RR-management on the GS side arises in two different contexts as follows:

- at the original GS serving the AS before the handover;
- at the target GS to be used by the AS after the handover.

NOTE: Original and target GS may coincide. This intra-cell handover is a special case of the general procedure and no special procedure is defined for this purpose.

The procedure at the original GS shall be as follows:

- for handover initiated by the AS, the procedure shall be started with a HO-REQUEST message received from the AS;
- for intra-cell handover to different slots or a different carrier at the same GS for traffic balancing, the procedure may be initiated by the GS.

In both cases a handover request message shall be issued on the network side with a RR-HO-REQUEST message.

If the network cannot establish the required resources, it shall respond with a RR-HO-REJECT message indicating the cause of the rejection. RRM shall then issue a HO-REJECT message to the AS which shall end the handover procedure.

If all resources are successfully established, the network shall respond with an RR-HO-COMMAND message that indicates the resource assigned at the new GS. The GS shall then issue a HO-COMMAND message with the following parameters:

- the channel number;
- description of the allocated resources, including the slot number for the negotiation slot.

After sending this message the GS shall start the timer T3104.

After successful handover of the AS to the new GS, the network shall respond with an RR-HO-COMplete message. The GS shall then reset timer T3100 and shall release all resources.

The procedure at the new GS shall be as follows:

- if the GS receives a RR-HO-REQUEST message from the network, it shall check whether the required resources are available. If this is not the case, the GS shall respond with an RR-HO-REJECT message indicating the nature of the failure as a parameter;
- else the GS shall set up all required resources for the AS, and shall respond with a RR-HO-COMMAND message, indicating the allocated resources, start timer T3100 and wait for a channel access transaction by the AS;

- if the channel access transaction is indicated by layer 1 in an MPH-CA-INDICATION primitive, the GS shall set timer T3103 and shall wait for establishment of the data link and the HO-COMplete message from the AS. After reception of the HO-COMplete message the GS shall reset timers T3103 and T3100 and shall issue a HO-COMplete message to the network with a RR-HO-COMplete message.

#### **10.11.3.5.2.2 Handover procedures on AS side**

When a handover decision arises in the AS according to the criteria described in subclause 8.10, the AS shall issue a HO-REQUEST message to the GS, start timer T3050 and wait for the HO-COMMAND message from the GS. In this state the AS shall take no action that shall modify the radio resource.

When a handover decision arises in the GS, the procedure shall start with the reception of a HO-COMMAND message from the GS.

In either of the above cases the AS shall, after the reception of a HO-COMMAND message, suspend the data link, switch to the new resource given by the HO-COMMAND message, command a channel access transaction to layer 1, resume the data link and shall issue a HO-COMplete message to the new GS.

#### **10.11.3.5.2.3 Allocation of the new resources to the used Ba, Ma, La channels**

The global allocation of slots at the new GS shall be transmitted to the AS in the HO-COMMAND message. The mapping of the different TCH's to the allocated slots is implicitly defined by a definite allocation strategy which is described in the following paragraphs.

The mapping of the channel types to the new slot allocation shall be carried out as follows:

- a) find the slot pattern for a Ba channel that is contained in the globally allocated slots and has the lowest possible slot numbers. Allocate these slots to the Ba channel with the lowest TI;
- b) if any Ba channels remain, repeat the selection of a Ba slot pattern described in 1a with the remaining slots. Allocate these slots to the Ba channel with the second lowest TI;
- c) repeat, until the last Ba channel is allocated;
- d) replace Ba by Ma in a) - c) and use the same procedure to allocate the remaining slots to the Ma channels;
- e) replace Ba by La in a) - c) and use the same procedure to allocate the last remaining slots to the La channels.

The mapping of Ba, Ma, La channels on the frame (slot numbers) shall be as specified in subclause 8.6.

The assignment of slots to traffic channels in the new GS shall be consistent with this subclause.

#### **10.11.3.5.2.4 Physical channel and data link establishment**

For the establishment of the new assigned channels the AS shall initiate a CHANNEL-ACCESS transaction. This transaction shall be handled on layer 1 and shall conform to subclause 8.5.4. The layer 2 establishment process shall be as described in sub-clause 9.6.5.4.4. The layer 3 data shall contain the identity of the AS and the initial transmit power.

The timer T3100 shall be started in the new GS, and shall control the allowed time delay from the beginning of the handover process in the GS (initiated by the HO-COMMAND) to the reception of a HANDOVER COMPLETE message from the aircraft.

When receiving a MPH-CA-CONFIRM primitive from layer 1 RRM shall control the establishment of the data link layer by the timer T3103.

After starting the channel access procedure in the AS, layer 1 shall wait for a response from the new GS.

#### **10.11.3.5.2.5 Handover completion**

A successful handover to the new GS or channel configuration shall be terminated by the RRM of the AS by sending a HO-COMPLETE message to its peer in the new GS. The GS shall then transmit a HO-COMPLETE message to the old GS which shall terminate the handover process on its side by the release of all previously allocated resources.

#### **10.11.3.5.2.6 Abnormal cases**

The abnormal cases which shall activate a failure message are:

- successful re-establishment to the old GS or channel configuration. The successful re-establishment to the old GS shall be terminated by sending a HO-FAILURE message to the old GS with a cause parameter indicating the re-establishment. The RR-HO-FAILURE shall be also sent to the new GS. The new GS shall then terminate the handover process by the release of all allocated resources;
- timer T3100 due to the lack of receipt of a HANDOVER-COMPLETE message from the AS. A HANDOVER FAILURE containing the handover reference shall be sent to the old GS and the allocated resources shall then return to the idle state;
- the timer T3103 times out because of failure to establish a data link connection to the new GS. If the timer T3103 expires before the reception of a DL-ESTABLISH-INDICATION primitive the allocated resources shall be released and layer 1 shall be re-tuned to the previous configuration. A RR-HO-FAILURE shall be sent to the corresponding GS to stop the handover process;
- the timer T3104 times out because neither a RR-HO-COMPLETE message from the new GS nor a message indicating the re-establishment of the data link at the old GS is indicated.

If the re-establishment procedure is not successful, either because the channel access failed or the data link could not be re-established, the RRM shall start the release of all allocated channels by a DL-RELEASE-REQUEST primitive with the parameter set to "Local end release". The initiation of the local end release procedure by the data link layer shall be indicated by the DL-RELEASE-CONFIRM primitive. The MPH-CNFG-REQUEST shall re-tune the frequency of the physical layer from the previously allocated channels. The RRM shall then send an RR-ABORT-INDICATION to the CC or MR which shall indicate the cause of the abort "Handover re-establishment failure".

If the RR management at the AS side is in a state other than DT, and a handover situation occurs, a RR-ABORT-INDICATION primitive and a local-end-release of the DL shall terminate the connection to the GS.

A ground network failure shall be handled as described in subclause 10.11.3.7.3.

#### **10.11.3.5.3 Additional channel assignment**

The purpose of the additional assignment procedure is to allocate additional dedicated channels to an AS while keeping the previously allocated channels. In particular the existing DCCH and TCH channels are not modified and signalling exchanges are not interrupted.

The additional assignment procedure is only used in the DT state and shall be initiated by the AS.

##### **10.11.3.5.3.1 Additional assignment procedure initiation**

The additional assignment procedure shall be initiated in the AS by an RR-Establish-Request primitive from the CC or MR to the RRM. The RRM shall then send an ESTABLISH-REQUEST message to the GSS on the main DCCH. The parameter of this message shall be a description of the requested resources.

#### **10.11.3.5.3.2 Additional assignment completion**

The additional assignment shall be terminated by the response message from the GSS side by sending a ESTABLISH-CONFIRM message if resources are available. On receipt of the ESTABLISH-CONFIRM message the AS shall switch the physical layer to the assigned resources and sends a RR-Establish-Confirm primitive to the upper sub-layer.

A lower layer failure and a ground network failure shall be handled as described in subclauses 10.11.3.7.2 and 10.11.3.7.3.

#### **10.11.3.5.3.3 Abnormal cases**

If the GSS is unable to provide the requested resources it shall send an ESTABLISH-REJECT message. At the AS side RRM shall indicate this reject to the CM sub-layer and shall return to DT state.

A lower layer failure and a ground network failure shall be handled as described in subclauses 10.11.3.7.2 and 10.11.3.7.3.

#### **10.11.3.5.3.4 Remap procedure**

When the GS receives an ESTABLISH REQUEST from the AS it allocates radio resources. The GS shall prepare its layer 1 by using the remap procedure. If the remap initialisation is successful the GS RRM shall transmit an ESTABLISH CONFIRM to the AS with a list of time slots. The AS shall then prepare its layer 1 using the remap procedure. If the AS remap procedure is successful the RRM entities at both sides shall receive a positive remap confirm (or indication) from layer 1.

At the AS, RRM shall inform the upper layers that the resource is established. A remap failure shall be handled as described in subclause 10.11.3.7.4.

#### **10.11.3.5.4 Release of assigned channels**

A change of channel configuration to release a channel may be requested by upper layers.

The purpose of this procedure is to deactivate part of the dedicated channels in use. The physical channel configuration remains dedicated.

The partial release procedure shall be initiated by the AS.

##### **10.11.3.5.4.1 Release initiation of assigned channels**

The AS shall initiate the release by a RR-DISCONNECT-REQUEST primitive which shall initiate the switching from traffic slots to control slots at the AS side. The release of the resource allocated to a channel shall be commanded by a RR-RELEASE-REQUEST primitive. When MR has finished sending OM data a RESOURCE-RELEASE-REQUEST message shall be sent to the GS which shall release the resources and shall confirm the release by sending a RESOURCE-RELEASE-CONFIRM message to the AS. After the confirmation of the release the RRM shall send a RR-RELEASE-CONFIRM primitive to CC which shall terminate the release procedure.

When there is no TCH in use, but paging resources are being used, there shall be no switching from traffic to control slots carried out and no RR-DISCONNECT-REQUEST shall be transmitted.

The release of the last call on a radio channel shall be handled as described in subclause 10.11.3.6.1.

##### **10.11.3.5.4.2 Abnormal cases**

A lower layer failure shall be treated as specified in subclause 10.11.3.7.2.

### **10.11.3.6 RR-connection release**

The RR-connection release procedure shall terminate the RR-connection between the AS and the GS.

An alternative procedure (described in subclause 10.11.3.7) shall be used if MR had requested to send OM data.

#### **10.11.3.5.4.3 Remap procedure for radio resource release**

When the GS receives a RESOURCE RELEASE REQUEST from the AS it allocates radio resources. The GS shall prepare its layer 1 by using the remap procedure. If the remap initialisation is successful the GS RRM shall transmit a RESOURCE RELEASE CONFIRM to the AS with a list of time slots. The AS shall then prepare its layer 1 using the remap procedure. If the AS remap procedure is successful the RRM entities at both sides shall receive a positive remap confirm (or indication) from layer 1.

At the AS, RRM shall inform the upper layers that the resource is established. A remap failure shall be handled as described in subclause 10.11.3.7.4.

#### **10.11.3.6.1 Normal release**

The purpose of this procedure is to de-activate the last dedicated channel in use. When the last channels are released the AS shall return to IDLE mode.

##### **10.11.3.6.1.1 Channel release termination**

The termination of the RR-connection shall be initiated by a RR-RELEASE-REQUEST primitive from the CC or maintenance resource sub-layer at the AS side. A RESOURCE-RELEASE-REQUEST message shall be sent to the GS. The GS side shall respond with a RESOURCE-RELEASE-CONFIRM message and the AS side shall confirm the release to the CC or MR entity using the RR-RELEASE-CONFIRM primitive. RRM at the AS side shall then initiate the data link release by sending a DL-RELEASE-REQUEST primitive to layer 2. After the data link release has been confirmed by a DL-RELEASE-CONFIRM primitive, RRM shall configure layer 1 and shall return to IDLE mode.

At the GS side, after the RESOURCE-RELEASE-CONFIRM message has been sent to the AS, RRM shall return to the CONNECTED state and shall wait for the release of the data link. After this is indicated by a DL-RELEASE-INDICATION primitive, layer 1 shall be configured and the remaining resources shall be released. RRM at the GS side shall then enter the IDLE mode.

##### **10.11.3.6.1.2 Abnormal cases**

A lower layer failure is treated as specified in subclause 10.11.3.8.

#### **10.11.3.7 Alternative procedure**

##### **10.11.3.7.1 General**

When MR sends OM data, RRM shall keep the resources for MR to transmit these OM data.

##### **10.11.3.7.1.1 Channel release initiation**

The initiation of the RR connection release procedure is similar to that described in subclause 10.11.3.5.4 (partial channel release) except that this applies when the resources shall be kept for transmission of OM data.

The alternative release procedure shall start with the receipt of an RR-RELEASE-REQUEST primitive from CC or MR at the AS side. A RESOURCE-RELEASE-REQUEST message shall be sent to the GSS which shall be confirmed by a RESOURCE-RELEASE-CONFIRM message. This shall be confirmed by the AS sending a RR-RELEASE-CONFIRM primitive back to CC or MR level. The RRM at the AS shall enter the OM state.

The previously used resources shall be kept for signalling, DCCH, and shall not undergo handover if no other resources are allocated to the AS.

#### **10.11.3.7.1.2 Additional signalling from the maintenance resource entity**

In the OM state the MR entity shall transmit data on the DCCH to the GSS. The OM data messages shall be transmitted with a TI value of 0.

#### **10.11.3.7.1.3 New set-up of a call or paging resources**

If a new call or paging request occurs in the OM state the AS sends an ESTABLISH-REQUEST message via the existing signalling link to the GS. The GS processes the request as if it were the first request after an AS entry. The GS allocates the resources and assigns the TI value to the allocated resources. At the AS, RRM moves to the DT state.

#### **10.11.3.7.1.4 Channel release termination**

Procedure at the AS side:

The termination of the RR connection shall be initiated by a RR-RELEASE-REQUEST primitive from the MR sub layer at the AS side. The RRM shall then send a RESOURCE-RELEASE-REQUEST message to its peer at the GS side. On receipt of the RESOURCE-RELEASE-CONFIRM message the RRM shall confirm the release to the MR sub-layer using the RR-RELEASE-CONFIRM primitive. RRM at the AS side shall then initiate data link release by sending a DL-RELEASE-REQUEST primitive to layer 2. The data link release shall be confirmed by a DL-RELEASE-CONFIRM primitive. RRM shall reconfigure layer 1 and return to the idle state.

Procedure at the GS side:

On receipt of a RESOURCE-RELEASE-REQUEST message the RRM shall send a RESOURCE-RELEASE-CONFIRM message and shall await release of the data link. Release of the data link shall be notified to the RRM by a DL-RELEASE-INDICATION primitive. On receipt of this indication the RRM shall reconfigure layer 1 and release the remaining resources. RRM at the GS side shall then enter the idle state.

#### **10.11.3.7.1.5 Abnormal cases**

When a handover is requested while the AS is in the OM state a local-end-release procedure shall be initiated by the AS.

A lower layer failure shall be treated as specified in subclause 10.11.3.7.2.

#### **10.11.3.7.2 Radio link failure**

The main part of the description of the procedure concerns the "normal" cases, i.e. without any occurrence of loss of communication means.

A separate paragraph at the end of the description of each procedure treats the cases of loss of communication means, called the "radio link failure".

In RR-connected mode, in most of the cases the reaction of the AS or the GS is the same. The reactions are described in this subclause to avoid repetitions.

A radio link failure may be detected in several ways. First by analysis of receptions at layer 1, as specified in subclause 8.5. Second, by a data link layer failure on the control channel, as specified in clause 9. Third, in some cases by the elapse of timers that are started to detect the lack of answer from the peer entity.

The two first cases are grouped in the following under the term "lower layer failure".

#### **10.11.3.7.2.1 AS side**

The general reaction to a radio link failure on the AS side is to abort the RR connection.

When a radio link failure has been detected, an indication shall be passed to the MR entity on the AS side.

The data link shall be released by a local end release procedure. In the confirming primitive the data link layer shall inform the RRM whether there were any outstanding messages.

#### **10.11.3.7.2.2 GS side**

If a radio link failure occurs at the GS side, the corresponding procedure as in subclause 10.11.3.7.2.1 shall be used.

#### **10.11.3.7.3 Ground network failure**

If a ground network failure occurs (i.e. between the GS and the GSC) the GS side shall request the abort of all allocated resources by sending a RESOURCE-ABORT-REQUEST message to the AS. The AS shall then confirm this request by a RESOURCE-ABORT-CONFIRM message to the GS and the normal release procedure of the data link shall be used to release the allocated resources. The AS shall indicate a RR-ABORT-INDICATION primitive to CC or MR which shall give the cause of the abort to the upper layer. Both sides shall then enter the idle mode.

#### **10.11.3.7.4 Remap failure**

If a remap failure occurs at the GS side the GS shall determine that the RRM peer entities are no longer coherent. RRM at the GS side shall locally disconnect the data link, release all resources and inform the higher layers.

#### **10.11.3.7.5 Remap interruption**

A remap procedure shall not be interrupted due to another remap request on the set or a sub-set of the slots involved in the remap in progress.

### **10.11.4 Elementary procedures for circuit-switched CC**

#### **10.11.4.1 Overview**

##### **10.11.4.1.1 General**

This subclause describes a set of procedures combined in the CC entity. The general purpose of these procedures is to establish, maintain and terminate circuit-switched connections across a TFTS network and other networks to which the TFTS network is connected.

Figure 50 gives an overview of the main states and transitions on the AS side, and figure 51 gives an overview of the main states and transitions on the GSS.

Detailed description of the procedures for CC are given in this subclause in terms of:

- the sequence of messages defined which are transferred across the radio interface (reference point Ua); and
- the information processing and actions that take place at the AS side and the GSS side.

Detailed System Description Language (SDL) diagrams for CC of circuit-switched calls are contained in subclause 10.11.11.



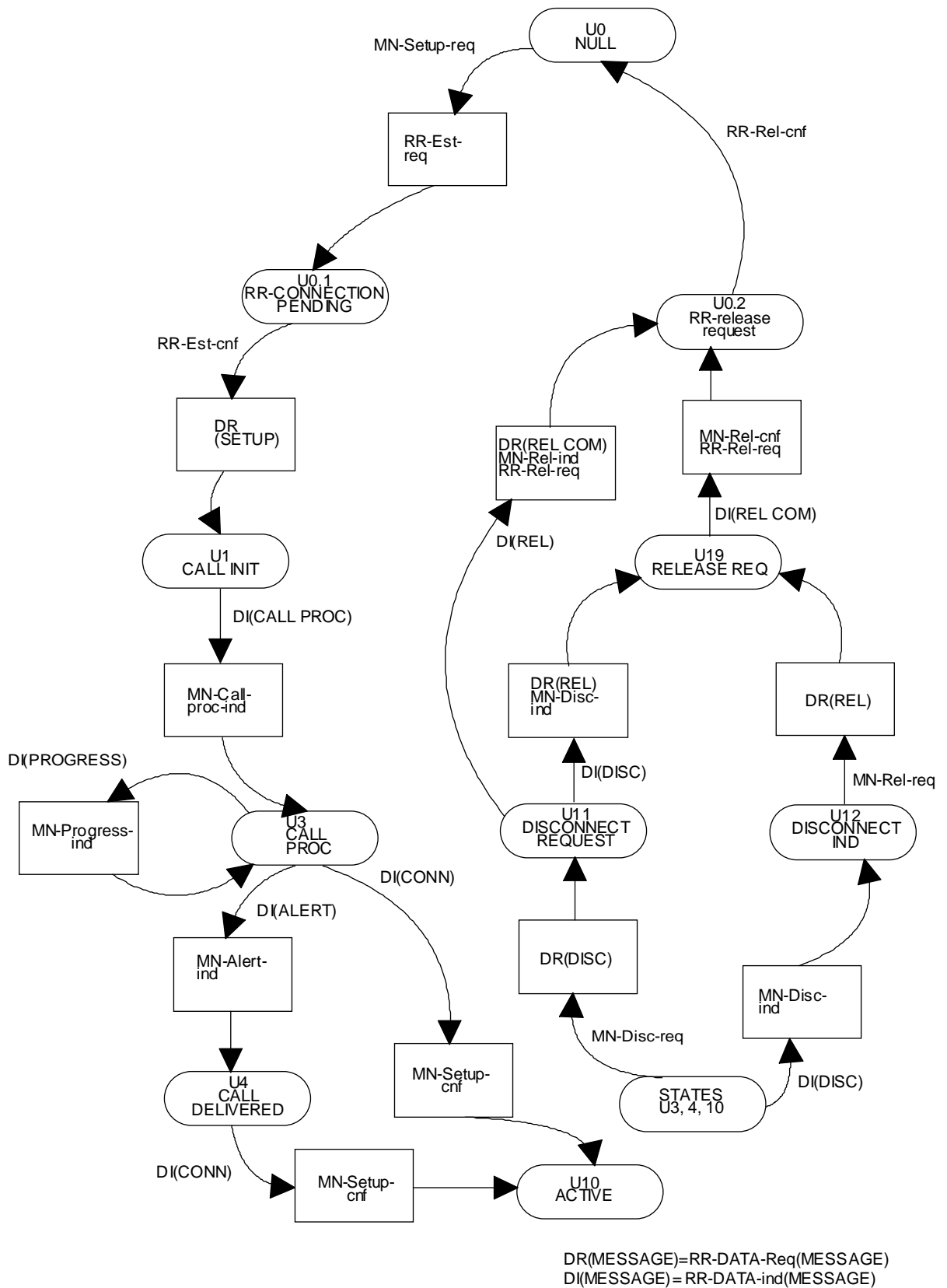


Figure 50: Overview Call Control protocol/AS side

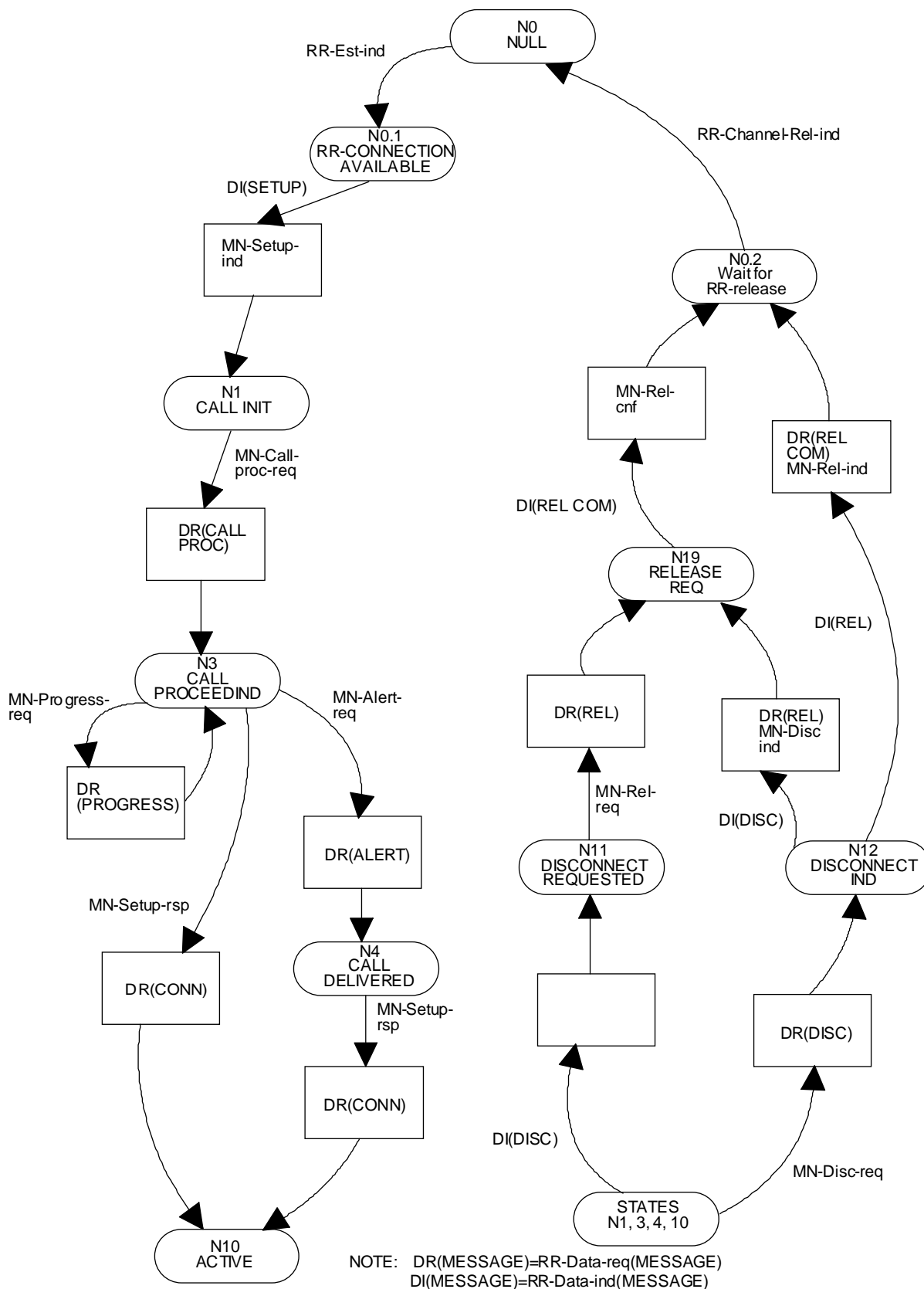


Figure 51: Overview Call Control protocol/GSS side

#### 10.11.4.1.2 CC states

##### 10.11.4.1.2.1 Call states at the AS side of the interface

The call states that may exist on the AS side of the radio interface are defined in this subclause.

**NULL (U0):** No call exists.

**RR-CONNECTING PENDING (U0.1):** This state exists for an aircraft originating call, when the AS has made a request for radio resources.

**RR-RELEASE REQUEST (U0.2):** This state exists when the AS has made a request to release used radio resources.

**CALL INITIATED (U1):** This state exists for an aircraft originating call, when the AS requests call establishment from the GSS.

**AIRCRAFT ORIGINATING CALL PROCEEDING (U3):** This state exists for an aircraft originating call when the AS has received acknowledgement that the GSS has received all call information necessary to effect call establishment.

**CALL DELIVERED (U4):** This state exists for an aircraft originating call, when the calling AS has received an indication that remote user alerting has been initiated.

**ACTIVE (U10):** This state exists for an aircraft originating call when the AS has received an indication that the remote user has answered the call.

**DISCONNECT REQUEST (U11):** This state exists when the AS has requested the GSS to clear the end-to-end connection (if any) and is waiting for a response.

**DISCONNECT INDICATION (U12):** This state exists when the AS has received an indication to disconnect because the GSS has disconnected the end-to-end connection (if any).

**RELEASE REQUEST (U19):** This state exists when the AS has requested the GSS to release and is waiting for a response.

##### 10.11.4.1.2.2 Call states at the GSS side of the interface

The call states that may exist on the GSS side of the radio interface are defined in this subclause.

**NULL (N0):** No call exists.

**RR-CONNECTION AVAILABLE (N0.1):** This state exists when radio resources are available on request by the peer CC entity.

**WAIT FOR RR RELEASE (N0.2):** This state exists when the GSS is waiting for release of used radio resources.

**CALL INITIATED (N1):** This state exists for an aircraft originating call when the GSS has received a call establishment request but has not yet responded.

**AIRCRAFT ORIGINATING CALL PROCEEDING (N3):** This state exists for an aircraft originating call when the GSS has sent acknowledgement that the GSS has received all call information necessary to effect call establishment.

**CALL DELIVERED (N4):** This state exists for an aircraft originating call when the GSS has indicated that remote user alerting has been initiated.

**ACTIVE (N10):** This state exists for an aircraft originating call when the GSS has indicated that the remote user has answered the call.

**DISCONNECT REQUEST (N11):** This state exists when the GSS has received a request from the AS to clear the end-to-end connection (if any).

**DISCONNECT INDICATION (N12):** This state exists when the GSS has disconnect the end-to-end connection (if any) and has sent an invitation to disconnect the AS-GSS connection.

**RELEASE REQUEST (N19):** This state exists when the GSS has requested the AS to release and is waiting for a response.

#### **10.11.4.1.3 Circuit-switched CC procedures**

The call states referred to cover, the states perceived by the GSS, states perceived by the AS and states which are common to both AS and GSS.

All messages in this subclause contain functional information elements. Functional information elements are characterized as requiring a degree of intelligent processing by the terminal in either their generation or analysis.

The procedures needed for CC are:

- call establishment procedures;
- call clearing procedures;
- call information phase procedures;
- miscellaneous procedures.

NOTE: The contents of the specific messages are only given for better understanding. A complete description of the messages and their contents is given in subclause 10.11.7.

#### **10.11.4.2 Aircraft originating call establishment procedures**

##### **10.11.4.2.1 General**

Before call establishment may be initiated the peer-to-peer connection between the RRM sub-layers in the AS and in the GSS shall be established.

The CC entity of the AS shall request the RR sub-layer for the establishment of indicated radio resources. Timer T303 shall then be set and the "RR-CONNECTING PENDING" state entered.

When indicated radio resources are established, a confirmation shall be given to indicate that the RR is ready for data transfer and the first CC message (SETUP) to the GSS shall be sent.

On the GSS side, the RR shall indicate that radio resources has been established on request by the peer CC entity and the "RR-CONNECTION AVAILABLE" state has been entered.

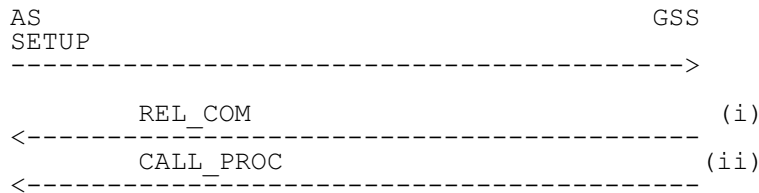
##### **10.11.4.2.2 Call request**

When establishment of indicated radio resources has been confirmed, the CC entity of the AS shall initiate call establishment by transferring a SETUP message across the radio interface. Following the transmission of the SETUP message, the call shall be considered by the AS to be in the "CALL INITIATED" state. This state shall be supervised by timer T303, which has already been set when entering the "RR-CONNECTING PENDING" state.

The SETUP message shall contain all the information required by the GSS to process the call and in particular, the called party address information.

Abnormal case:

Since timer T303 is used to supervise the two consecutive states, "RR-CONNECTING PENDING" and "CALL INITIATED", the expiry of timer T303 shall follow different actions depending of the respective state: If the timer expires in the "RR-CONNECTING PENDING" state, the radio resource establishment request in progress shall be aborted and the user shall be informed about the rejection of the call. If timer T303 expires in the "CALL INITIATED" state (i.e. before any of the CALL PROCEEDING or RELEASE COMPLETE messages has been received), the AS shall clear the call by sending a RELEASE COMPLETE, request the release of the used radio resources, and shall then return to the NULL state.



**Figure 52: Aircraft originated call initiation and possible subsequent responses**

**10.11.4.2.3 Invalid call information**

If, following the receipt of SETUP message, the network determined that the call information received from the AS is invalid (e.g. invalid number), then the GSS shall initiate call clearing as defined in subclause 10.11.4.4 with the a cause as one of the following:

- # 1 "un-assigned (unallocated) number";
- # 2 "no route to destination";
- # 22 "number changed";
- # 28 "invalid number format (incomplete number)".

**10.11.4.2.4 Call proceeding**

As en-bloc sending shall be used (i.e. the GSS can determine that the SETUP message contains all the information required from the AS to establish the call) the GSS shall:

- send a CALL PROCEEDING message to the AS to indicate that the call is being processed; and
- enter the "AIRCRAFT ORIGINATING CALL PROCEEDING" state.

When the AS receives the CALL PROCEEDING message, the AS shall:

- reset timer T303;
- set timer T310; and
- enter the "AIRCRAFT ORIGINATING CALL PROCEEDING" state.

NOTE 1: Overlap sending is not supported.

NOTE 2: T310 is not set if progress indicator 1 or 2 has been delivered in the CALL PROCEEDING message or in a previous PROGRESS message.

Similarly, if the GSS determines that a requested service is not authorized or is not available, the GSS shall initiate call clearing in accordance with subclause 10.11.4.4 with one of the following causes:

- # 57 "bearer capability not authorized";

- # 58 "bearer capability not presently available";
- # 63 "service or option not available, unspecified";
- # 65 "bearer service not implemented".

Abnormal case:

If timer T310 expires before any of the ALERTING, CONNECT or DISCONNECT messages has been received, the AS shall perform the clearing procedure described in subclause 10.11.4.4.

#### **10.11.4.2.5 Notification of interworking in connection with call establishment**

In this subclause, the term "interworking" is used only in the meaning of interworking with a network other than TFTS or ISDN, not as interworking between TFTS and ISDN since this is the normal case. In this sense, TFTS and ISDN are seen within the same environment, called the TFTS/ISDN environment.

During call establishment, the call may leave a TFTS/ISDN environment; e.g., because of interworking with another network, with a non-TFTS/ISDN user, or with non-TFTS/ISDN equipment within the called user's premises. When such situations occur, a progress indicator information element shall be returned to the calling AS either:

- in an appropriate CC message when a state change is required (e.g. ALERTING or CONNECT); or
- in the PROGRESS message when no state change is appropriate.

The progress indicator information element sent to the AS may contain one of the following progress description values:

- 1 "call is not end-to-end TFTS/ISDN; further call progress information may be available in-band";
- 2 "destination address is non-TFTS/ISDN";
- 4 "call has returned to TFTS/ISDN".

If the progress indicator information element is included in a CC message, the procedures as described in the remainder of subclause 10.11.4.2 apply. If the progress indicator information element is included in the PROGRESS message, no state change shall occur and timer T310 shall be reset in the AS. In both cases, if indicated by the progress indicator information element, the AS shall connect to the traffic channel (if not connected already).

#### **10.11.4.2.6 Call confirmation indication**

Upon receiving an indication that user alerting has been initiated at the called address, the GSS shall send an ALERTING message across the radio interface of the calling AS and shall enter the "call delivered" state.

When the AS receives the ALERTING message, the AS shall begin an internally-generated alerting indication, shall reset timer T310 (if running) and shall enter the "call delivered" state.

#### **10.11.4.2.7 Call connected**

Upon receiving an indication that the call has been accepted, the GSS shall send a CONNECT message across the radio to the calling AS, request RR to connect the user connection to the radio path (if not connected already) and shall enter the "active" state.

NOTE: This message indicates to the calling AS that a connection has been established through the network.

On receipt of the CONNECT message the calling AS shall request the RR to connect the user connection to the radio path. Any locally generated alerting indication (if applied) shall cease, timer T310 (if running) shall be reset and RR shall enter the active state. The single exception to this is when the AS has previously received a connect instruction contained in the progress indicator element of a previous message. In this case the already established connection shall be maintained.

#### **10.11.4.2.8 Call rejection**

Upon receiving an indication that the network or the called user is unable to accept the call, the GSS shall initiate call clearing at the radio interface to the AS which originated the call, as described in subclause 10.11.4.4 using the cause provided by the terminating network or the called user.

#### **10.11.4.3 Signalling procedures during the active state**

##### **10.11.4.3.1 User notification procedure**

This procedure allows the GSS to notify an AS of any appropriate call-related event during the "active" state of a call. It also may allow an AS to notify the remote user of any appropriate call-related event during the "active" state of a call by sending a NOTIFY message containing a notification indicator to the GSS.

Upon receipt of a NOTIFY message, the GSS shall send a NOTIFY message containing the same notification indicator to the user involved in the call.

No state change shall occur at any of the interface sides following the sending or the receipt of a NOTIFY message.

##### **10.11.4.3.2 Call rearrangements**

Call re-arrangements on the air interface shall not be supported by SUSPEND and RESUME messages.

However if a remote user initiates call re-arrangements, the GSS shall inform the AS by means of a NOTIFY message.

In a similar way the AS shall inform the GSS about re-arrangements by sending a NOTIFY message (e.g. change of user equipment connected to the AS).

##### **10.11.4.3.3 Dual Tone Multi-Frequency protocol control procedure**

The procedures described in this subclause supports DTMF only in the direction AS to network.

DTMF is an in-band, one out of four plus one out of four, signalling system primarily used for terminal equipment in telecommunication networks. The support of DTMF is described in ETS 300 326-1 [12]. The use of DTMF shall only be permitted when the speech teleservice is in use.

NOTE: Since the DTMF protocol messages are sent in a store and forward mode on the signalling channel, the control of the device at the far end may be delayed dependent on the load and quality of the channels.

##### **10.11.4.3.3.1 Send DTMF request by the AS**

On request by the user, a converted DTMF tone, shall be transmitted as a DTMF digit in a SEND DTMF message on an established DCCH. The message shall contain the value of the digit to be transmitted. The DTMF tone set which shall be supported shall comply with CCITT Recommendation Q.23 [18].

Only a single digit shall be transferred in each SEND DTMF message.

#### 10.11.4.3.3.2 Send DTMF response by the network

Upon receiving a SEND DTMF message the GSS shall re-convert the received digit back into a DTMF tone which was sent toward the remote user and shall return a SEND DTMF ACKNOWLEDGE message to the AS. The SEND DTMF ACKNOWLEDGE message shall cause the AS to generate an indication to the initiating user in the AS.

If the GSS cannot accept the SEND DTMF message a SEND DTMF REJECT message shall be sent to the AS. In this case a failure tone shall be generated by the AS to indicate to the user that the DTMF procedure has failed.

#### 10.11.4.3.3.3 Sequencing of subsequent send DTMF requests by the AS

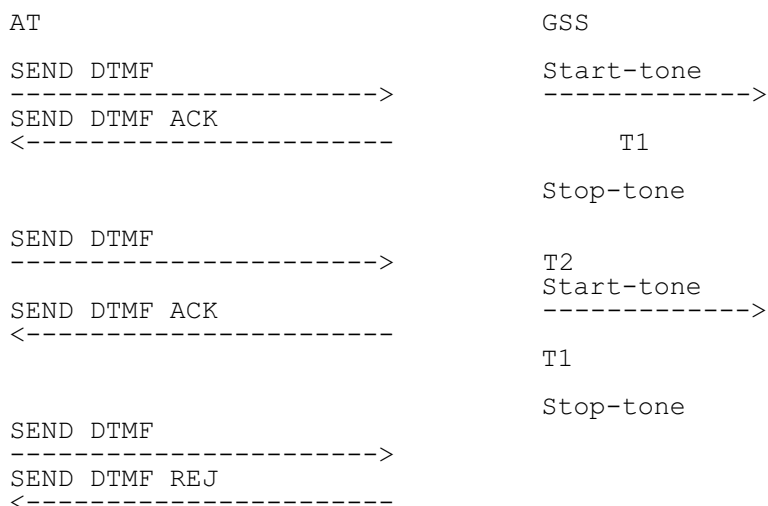
The tone generated by the GSS shall be in accordance with CEPT Recommendation T/CS 46-02 [19].

The signal duration shall be of fixed length, T1.

The minimum pause duration, between two subsequent tones generated towards the network, should be at least of length T2.

T1 and T2 are specified in CEPT Recommendation T/CS 34-08 [20].

The GSS shall ensure that tones are not generated towards the network faster than the minimum time mentioned above will allow.



Start\_tone: start tone transmission into the PSTN/ISDN  
Stop\_tone: stop tone transmission into the PSTN/ISDN

Figure 53: Multiple DTMF transmission

#### 10.11.4.4 Call clearing

##### 10.11.4.4.1 Terminology

The following terms are used in this ETS for the description of clearing procedures:

**connected:** A TCH is "connected" when the channel is part of a circuit-switched connection;

**disconnected:** A TCH is "disconnected" when the channel is no longer part of a circuit-switched connection, but is not yet available for use in a new connection.



#### 10.11.4.4.2 Exception conditions

Under normal conditions, call clearing shall be initiated when the AS or the GSS sends a DISCONNECT message and shall follow the procedures defined in subclauses 10.11.4.4.3 and 10.11.4.4.4 respectively.

As an exception to the above requirement, the GSS, in response to a SETUP message, shall reject a call by responding with a RELEASE COMPLETE message.

#### 10.11.4.4.3 Clearing initiated by the AS

Apart from the exceptions identified in subclause 10.11.4.4.2, the AS shall initiate clearing by sending a DISCONNECT message, setting timer T305, requesting RR to disconnect the user connection, and entering the "DISCONNECT REQUEST" state.

When an AS initiates call clearing by sending a RELEASE message, the procedures described in subclause 10.11.4.4.4 shall be followed.

Following the receipt of the DISCONNECT message the GSS shall request RR to disconnect the user connection and enter the "disconnect request" state. The GSS shall also initiate procedures to clear the network connection and the call to the remote user.

On receipt of the DISCONNECT message by the GSS, a RELEASE message shall be sent to the AS, timer T308 shall be set, and the GSS shall enter the "RELEASE REQUEST" state.

NOTE: The RELEASE message has only local significance and does not imply an acknowledgement of clearing from the remote user.

On receipt of the RELEASE message the AS shall:

- reset timer T305;
- send a RELEASE COMPLETE message;
- request the release of used radio resources;
- enter the "RR-RELEASE REQUEST" state awaiting confirmation; and
- enter the "NULL state".

Following the receipt of a RELEASE COMPLETE message from the AS, the GSS shall:

- reset timer T308;
- enter the "WAIT FOR RR-RELEASE" state;
- wait for the indication that used radio resources have been released;
- enter the "NULL" state.

Abnormal cases:

If the AS does not receive a RELEASE message in response to the DISCONNECT message before timer T305 expires, it shall send a RELEASE message to the GSS with the cause number originally contained in the DISCONNECT message, set timer T308, and enter the "RELEASE REQUEST" state.

In addition to the original clearing cause, the RELEASE message may contain a second cause information element with cause # 102 "recovery on timer expiry".

If a RELEASE COMPLETE message is not received by the GSS before the first expiry of timer T308, the RELEASE message shall be re-transmitted and timer T308 shall be set. If no RELEASE COMPLETE

message is received from the AS before timer T308 expires a second time, the GSS shall enter the "WAIT FOR RR-RELEASE" state, wait for the indication that used radio resources have been released, before returning to the "NULL" state.

#### **10.11.4.4.4 Clearing initiated by the GSS**

Apart from the exception conditions identified in subclause 10.11.4.4.2, the GSS shall initiate clearing by sending a DISCONNECT message and entering the "DISCONNECT INDICATION" state. The DISCONNECT message is a local command to clear the call.

When the GSS initiates call clearing by sending a RELEASE message, the procedures described in subclause 10.11.4.4.3 shall be followed.

##### **10.11.4.4.4.1 Clearing when tones/announcements provided**

When in-band tones/announcements are provided (see subclause 10.11.4.5.1), the GSS shall initiate clearing by sending a DISCONNECT message containing progress indicator #8 "in-band information or appropriate pattern now available", set timer T306, and enter the "DISCONNECT INDICATION" state.

On receipt of the DISCONNECT message with progress indicator #8, the AS shall:

- 1) if a traffic channel is not connected, continue clearing without connecting to the in-band tone announcement by sending a RELEASE message; setting timer T308, and entering the "RELEASE REQUEST" state;

The GSS shall, when receiving the RELEASE message, send a RELEASE COMPLETE message, reset timer T306, enter the "WAIT FOR RR-RELEASE" state, wait for the indication that used radio resources have been released, before returning to the "NULL" state;

- 2) if a traffic channel is connected, proceed in either of the following ways:

- connect to the in-band tone/announcement and enter the "DISCONNECT INDICATION" state; or
- continue clearing without connecting to the in-band tone/announcement by sending a RELEASE message, setting timer T308, and entering the "RELEASE REQUEST" state.

The GSS shall, when receiving the RELEASE message, send a RELEASE COMPLETE message, reset timer T306, enter the "WAIT FOR RR-RELEASE" state, wait for the indication that used radio resources have been released, before returning to the "NULL" state.

If timer T306 expires, the GSS shall continue clearing by sending the RELEASE message with the cause number originally contained in the DISCONNECT message, setting timer T308, and entering the "RELEASE REQUEST" state.

Upon receipt of the RELEASE message, the AS shall send a RELEASE COMPLETE message.

Following the receipt of a RELEASE COMPLETE message from the AS, the GSS shall reset timer T308, enter the "WAIT FOR RR-RELEASE" state, wait for the indication that used radio resources have been released, before returning to the "NULL" state.

When the AS and the GSS receive or send the RELEASE message, RR shall be requested to disconnect the user connection.

##### **10.11.4.4.4.2 Clearing when tones/announcements not provided**

When in-band tones and announcements are not provided, the DISCONNECT message does not contain progress indicator #8 "in-band information or appropriate pattern now available".

The GSS shall initiate clearing by sending a DISCONNECT message, set timer T305, request RR to disconnect the user connection and enter the "DISCONNECT INDICATION" state.

On receipt of the DISCONNECT message the AS shall send a RELEASE message, set timer T308, request RR to disconnect the user connection, and enter the "RELEASE REQUEST" state.

On receipt of the RELEASE message, the GSS shall reset timer T305, send a RELEASE COMPLETE message, enter the "WAIT FOR RR-RELEASE" state, wait for the indication that used radio resources have been released, before returning to the "NULL" state.

Abnormal cases:

If the GSS does not receive a RELEASE message in response to the DISCONNECT message before timer T305 expires, it shall send a RELEASE message to the AS with the cause number originally contained in the DISCONNECT message, set timer T308, and enter the "RELEASE REQUEST" state.

In addition to the original clearing cause, the RELEASE message may contain a second cause information element with cause #102 "recovery on timer expiry".

#### **10.11.4.4.3 Completion of clearing**

Following the receipt of a RELEASE COMPLETE message from the GSS, the AS shall reset timer T308, request the release of used radio resources, enter the "RR-RELEASE REQUEST" state, wait for confirmation, before returning to the "NULL state".

Abnormal cases:

If a RELEASE COMPLETE message is not received by the AS before the first expiry of timer T308, the RELEASE message shall be re-transmitted and timer T308 shall be set.

If no RELEASE COMPLETE message is received from the GSS before timer T308 expires a second time, the AS shall request the release of used radio resources, enter the "RR-RELEASE REQUEST" state, wait for confirmation, before returning to the "NULL state".

#### **10.11.4.4.5 Clear collision**

Clear collision occurs when both the AS and the GSS simultaneously transfer DISCONNECT messages specifying the same call.

When the GSS receives a DISCONNECT message whilst in the "DISCONNECT INDICATION" state, the GSS shall reset timer T305 or T306 (whichever is running), send a RELEASE message, set timer T308, and enter the "RELEASE REQUEST" state.

Similarly, when the AS receives a DISCONNECT message whilst in the "DISCONNECT REQUEST" state, the AS shall reset timer T305, send a RELEASE message, set timer T308, and enter the "RELEASE REQUEST" state.

Clear collision may also occur when both sides simultaneously transfer RELEASE messages related to the same call.

When the GSS receives a RELEASE whilst in the "RELEASE REQUEST" state the GSS shall reset timer T308, enter the "WAIT FOR RR-RELEASE" state, wait for the indication that used radio resources have been released, before returning to the "NULL" state.

When the AS receives a RELEASE whilst in the "RELEASE REQUEST" state the AS shall reset timer T308, request the release of used radio resources, enter the "RR-RELEASE REQUEST" state, wait for confirmation, before returning to the "NULL" state.

#### **10.11.4.5 Miscellaneous procedures**

##### **10.11.4.5.1 In-band tones and announcements**

When in-band tones/announcements not associated with a call state change, are to be provided by the network before reaching the "ACTIVE" state, a PROGRESS message shall be returned simultaneously with the application of the in-band tone/announcement. The PROGRESS message shall contain the progress indicator #8 "in-band information or appropriate pattern is now available".

When tones/announcements have to be provided together with a call state change, then the appropriate message (e.g. ALERTING, DISCONNECT etc..) with progress indicator #8 "in-band or appropriate pattern is now available" shall be sent simultaneously with the application of the in-band tone/announcement.

When the PROGRESS message is used, the AS may initiate clearing as a result of the applied in-band tone/announcement according to the procedure specified in subclause 10.11.4.4.3.

##### **10.11.4.5.2 Status procedures**

###### **10.11.4.5.2.1 Status enquiry procedure**

Whenever a CC entity wishes to check the correctness of a call state at a peer entity, a STATUS ENQUIRY message may be sent requesting the call state. This may in particular, apply to procedural error condition described in subclause 10.11.6.

Upon sending the STATUS ENQUIRY message, timer T322 shall be set in anticipation of receiving a STATUS message.

Whilst timer T322 is running, only one outstanding request for call state information shall exist.

If a clearing message is received before timer T322 expires, timer T322 shall be reset and call clearing shall continue.

Upon receipt of a STATUS ENQUIRY message, the receiver shall respond with a STATUS message, reporting the current call state and cause #30 "response to STATUS ENQUIRY" or #97 "message type non-existent or not implemented". Receipt of the STATUS ENQUIRY shall not result in a state change. The sending or receipt of the STATUS message in such a situation shall not directly affect the call state of either the sender or receiver.

The side having received the STATUS message shall inspect the cause information element and:

- if the STATUS message contains cause #97 "message type non-existent or not implemented", timer T322 shall continue to run awaiting an explicit response to the STATUS ENQUIRY message;
- if a STATUS message is received that contains cause #30 "response to status enquiry", timer T322 shall be reset and the appropriate action taken, based on the information in that STATUS message, relative to the current state of the receiver.

If timer T322 expires and a STATUS message with cause #97 was received, the appropriate action shall be taken, based on the information in the STATUS message, relative to the current call state of the receiver.

The following "appropriate action" may be implemented, however, the action in the following subclauses shall apply if it is implemented.

If timer T322 expires, and no STATUS message was received, the STATUS ENQUIRY message shall be re-transmitted once.

The call shall be cleared with cause #41, "temporary failure", if the STATUS ENQUIRY was re-transmitted. The GSS shall initiate the call clearing procedure according to subclause 10.11.4.4.4.

#### **10.11.4.5.2.2 Receiving a STATUS message by a CC-entity**

On receipt of a STATUS message, reporting an incompatible state, the receiving entity shall clear the call by sending the appropriate clearing message with cause #101 "MESSAGE NOT COMPATIBLE WITH CALL STATE".

Except for the following requirement, the determination of which states are incompatible is left as an implementation decision:

If a STATUS message is received in the "RELEASE REQUEST" state no action shall be taken.

NOTE: A STATUS message can not indicate "NULL" state, since there is no RR-connection available in that state.

A STATUS message may be received indicating a compatible call state but containing one of the following causes:

- #96 "mandatory information element error";
- #97 "message type non-existing or not implemented";
- #99 "information element nonexistent or not implemented"; or
- #100 "invalid information element contents".

In the above cases, the call shall be cleared according to subclause 10.11.4.4.

#### **10.11.5 Elementary procedures for maintenance resource management**

##### **10.11.5.1 Overview**

##### **10.11.5.1.1 General**

The MR entity provides a set of procedures for operation, maintenance and service purposes. This includes the establishment and termination of a point-to-point signalling link between the AS and the GSS.

Four different procedures shall be available at the MR entity:

- shutdown procedure;
- procedure to page a subscriber;
- engineering paging procedure; and
- a procedure for data transfer for operation and maintenance purposes.

Subsequently these procedures are described as seen from the MR management sub-layer. The RRM co-existing procedures are described in subclause 10.11.3.

##### **10.11.5.2 GSS originated signalling procedures**

##### **10.11.5.2.1 General**

GSS originated signalling procedures shall use the BCCH(D) channel to pass the service request messages via the RRM sub-layer to its peer entity at the AS side.

For the procedure to page a subscriber and for the engineering paging procedure the AS shall request the RRM sub-layer to establish a peer-to-peer connection between the RRM sub-layers on the AS and the GSS.

The procedures for shutdown and operation and maintenance purposes are different from the procedure described in this subclause. These procedures are described in subclauses 10.11.5.2.4 and 10.11.5.2.5.

The MR entity of the AS shall request from the RR sub-layer the establishment of radio resources. Timer T3010 shall then be set and the "RR-CONNECTION PENDING" state shall be entered.

On the GSS side RR shall indicate that a radio resource has been established on request by the peer MR entity and the DT state shall be entered.

When radio resources are established, on the AS side a confirmation shall be given to indicate the RR is ready for data transfer.

If the timer T3010 expires in the "RR-CONNECTION PENDING" state, the radio resource establishment request in progress shall be aborted and the corresponding peer entity informed of the cause for rejection of the request.

#### 10.11.5.2.2 Paging

When the MR management sub-layer on the GS side receives a paging request message from its peer entity at the GSS/fixed network side it shall request the RR management sub-layer using the RR-PAGE-REQUEST primitive to setup an equivalent message on the BCCH(D).

If the RR management sub-layer of the AS side detects a paging request message on the BCCH(D) it shall pass an RR-PAGE-INDICATION primitive to the MR sub-layer.

This primitive shall include a reference number and the MR management sub-layer shall initiate resource establishment by the RR management using the RR-ESTABLISH-REQUEST PRIMITIVE. The parameters of this message shall be a reference number and a transaction identifier.

After a successful establishment of the radio resource, RR management at the AS side shall confirm to the MR management sub-layer by using the RR-ESTABLISH-CONFIRM primitive.

The radio resource shall increase the capacity of the DCCH.

After the link has been established, the AS side shall send a PAGE-CHANNEL-RESPONSE message to its corresponding peer entity at the GS side. MR management at the GS side shall then inform the GSS/fixed network side about this acknowledgement.

For data transfer, both sides shall use PAGE-DATA-TRANSFER messages. The data field of these messages may contain system messages (see subclause 10.11.8.5.4.3) and the AS shall monitor these and store any diallable number contained therein and any resource request information such that a call can be established by the AS on the basis of this information.

NOTE: On an appropriate indication from other equipment on board the aircraft the AS could establish a call using the stored information.

The release procedure may be originated by the MR management at the AS or GS side. If it is originated by the AS, a PAGE-CHANNEL-RELEASE message shall be sent to its peer entity at GS side, request RRM at the AS side to release the allocated resources and shall set timer T3020. If it is originated by the GS side, a PAGE-CHANNEL-RELEASE message shall be sent to its peer entity at the AS side and the timer T3110 shall be set. The AS side shall then request the RRM to release the allocated resources and set timer T3020. On the GS side this shall be confirmed by the RRM by a confirmation primitive to the MR entity.

If the timer T3020 expires before the MR entity receives a confirmation of the release request, the allocated resources shall be released, timer T3020 reset and the AS shall enter the "IDLE" state, if it is the last existing paging resource, or shall return to the DT state.

If the MR entity at the GS side does not receive a confirmation from RRM that the corresponding resources have been released and timer T3110 expires, the MR management shall re-transmit the release message to its peer entity at the AS side and restart T3110.

If the MR entity at the GS side does not receive a confirmation from RRM that the corresponding resources have been released after the first re-transmission of the request message and the timer T3110 expires, the MR management at the GS side shall request the release of the radio resources, reset timer T3110 and return to the "IDLE" state: if it is the last existing paging resource, or shall return to the DT state.

If the MR receives a response message with an invalid page reference number it shall reply with a PAGE-CHANNEL-RELEASE message indicating the cause of the release. The AS shall then release the allocated resources as described above.

If a failure occurs during the established link, this shall be indicated to the MR management sub-layer on both sides by using the RR-ABORT primitive which shall also give the cause of the failure. At GS this shall be passed to the GSS/fixed network side.

#### **10.11.5.2.3 Engineering paging**

When the MR management sub-layer on the GS side receives an engineering paging request message from its peer entity at the GSS/fixed network side, it shall request the RR management sub-layer, using the RR-ENGPAGE-REQUEST primitive, to setup an equivalent message on the BCCH(D).

If the RR management sub-layer of the AS side detects an engineering paging request message on the BCCH(D) it shall pass an RR-ENGPAGE-INDICATION primitive to the MR sub-layer.

This primitive shall include a reference number and the MR management sub-layer shall initiate resource establishment by the RR management using the RR-ESTABLISH-REQUEST primitive. The parameters of this message shall be the capacity of requested resources, the reference number and a transaction identifier.

After successful establishment of the radio resource, RR management at the AS side shall confirm this to the MR management sub-layer by using the RR-ESTABLISH-CONFIRM primitive.

The radio resource shall increase the capacity of the DCCH.

After the link has been established the AS side shall send an ENGPAGE-CHANNEL-RESPONSE message to its corresponding peer entity at the GS side. MR management at the GSS/fixed network side shall inform the GSC about this acknowledgment.

For data transfer both sides shall use ENGPAGE-DATA-TRANSFER messages.

The release procedure may be originated by the MR management at the AS or GS side.

If release is originated by the AS, an ENGPAGE-CHANNEL-RELEASE message shall be sent to its peer entity at the GS side, a request to RRM at the AS side to release the allocated resources and timer T3020 shall be set.

If release is originated by the GS side, an ENGPAGE-CHANNEL-RELEASE message shall be sent to its peer entity at the AS side and the timer T3110 shall be set. The AS side shall request the RRM to release the allocated resources and shall set timer T3020. On the GS side this shall be confirmed by the RRM by a confirmation primitive to the MR entity.

If the timer T3020 expires before the MR entity had received a confirm upon a release request, the allocated resources shall be released, timer T3020 reset and the AS shall enter the "IDLE" state: if it is the last existing paging resource, or return to the DT state.

If the MR entity at GS side does not receive a confirmation from RRM that the corresponding resources have been released and timer T3110 expires, the MR management shall re-transmit the release message to its peer entity at the AS side and restart T3110.

If the MR entity at the GS side does not receive a confirmation from RRM that the corresponding resources have been released after the first re-transmission of the request message and the timer T3110 expires, the MR management at the GS side shall request the release of the radio resources, reset timer T3110 and return to the "IDLE" state: if it is the last existing paging resource, or return to the DT state.

If the MR receives a response message with a invalid engage reference number it shall reply with a ENGPAGE-CHANNEL-RELEASE message indicating the cause of the release (invalid reference number). The AS shall then release the allocated resources as described above.

If a failure occurs during the established link, this shall be indicated to the MR management sub-layer on both sides by using the RR-ABORT PRIMITIVE which shall also give the cause of the failure. At the GS this shall be passed to the GSS/fixed network.

#### **10.11.5.2.4 Shutdown**

When the MR management sub-layer on the GS side receives a shutdown request message from its peer entity at the GSC side, it shall request the RR management sub-layer using the RR-SHUTDOWN-REQUEST primitive to setup an equivalent message on the BCCH(D).

If there is no BCCH (D) at the GS, because all resources are allocated, the shutdown message shall be sent on the DCCH (the message shall be inserted into the layer 2 frame disregarding the last three octets of the defined message).

If the RR management sub-layer at the AS side detects a shutdown request message on the BCCH(D) or on the DCCH, it shall send a RR-SHUTDOWN-INDICATION primitive to the MR sub-layer indicating the requested time for shutdown as a parameter. The MR shall then send a RR-SHUTDOWN-COMMAND-INDICATION primitive to RR management to terminate all established links by a local-end-release of the data link. RRM shall then enter the "NULL" state and no further call establishment shall be possible.

If the shutdown is commanded for a finite time, MR management shall start timer T3060 for this duration. If T3060 expires, MR management shall send an RR-ACTIVATE-COMMAND-REQUEST primitive to RRM. RRM shall then enter the "IDLE" state and further call establishment shall be possible.

If the shutdown is commanded for an infinite time, the MR management shall only be reactivated by manual means.

#### **10.11.5.2.5 Operation and Maintenance (OM)**

If the MR entity has to send OM data, it shall pass a request to RRM a RR-ESTABLISH-REQUEST (OM) primitive. If there is a connection established and signalling capacity available on the DCCH this shall be confirmed by a RR-ESTABLISH-CONFIRM (OM) primitive.

For data transfer MRM shall use the OM-DATA-TRANSFER message.

When the OM transmission is finished, the MR shall pass an RR-RELEASE-REQUEST (OM) primitive to RR. If the last call has been released during the OM transmission, the radio resource shall be released as soon as the RR-RELEASE-REQUEST from MR is received.

If no connection is established and no signalling capacity is available on the DCCH the RR-ESTABLISH-REQUEST shall be rejected by a RR-RELEASE-CONFIRM (ERROR) primitive.



#### **10.11.5.2.5.1 General**

There are two priorities for the transmission of OM data by the MR entity at the AS side as follows:

- in the DT state, when a call is established or paging resources are allocated, the messages are given lowest priority compared to messages from CC or RRM;
- in the OM state, after the last call, or the release of the last paging channel when the remaining resources are specifically kept for the MR, OM messages are transmitted with high priority.

#### **10.11.5.2.5.2 Transmission of OM data with high priority**

After a release of existing resources the RRM shall indicate to MRM the availability of remaining signalling resources to transmit OM data. This shall be indicated by a RR-ESTABLISH-INDICATION primitive.

For the data transfer the MRM shall use the OM DATA TRANSFER message.

The release of the signalling link shall be initiated by the AS using the RR RELEASE REQUEST primitive sent to the RRM.

A priority change for OM data shall be indicated by the RRM.

If handover occurs in the situation where MRM transfers OM data with high priority this signalling link shall not be handed over but aborted by the RRM at the AS side and shall indicate this by a RR-ABORT-INDICATION primitive.



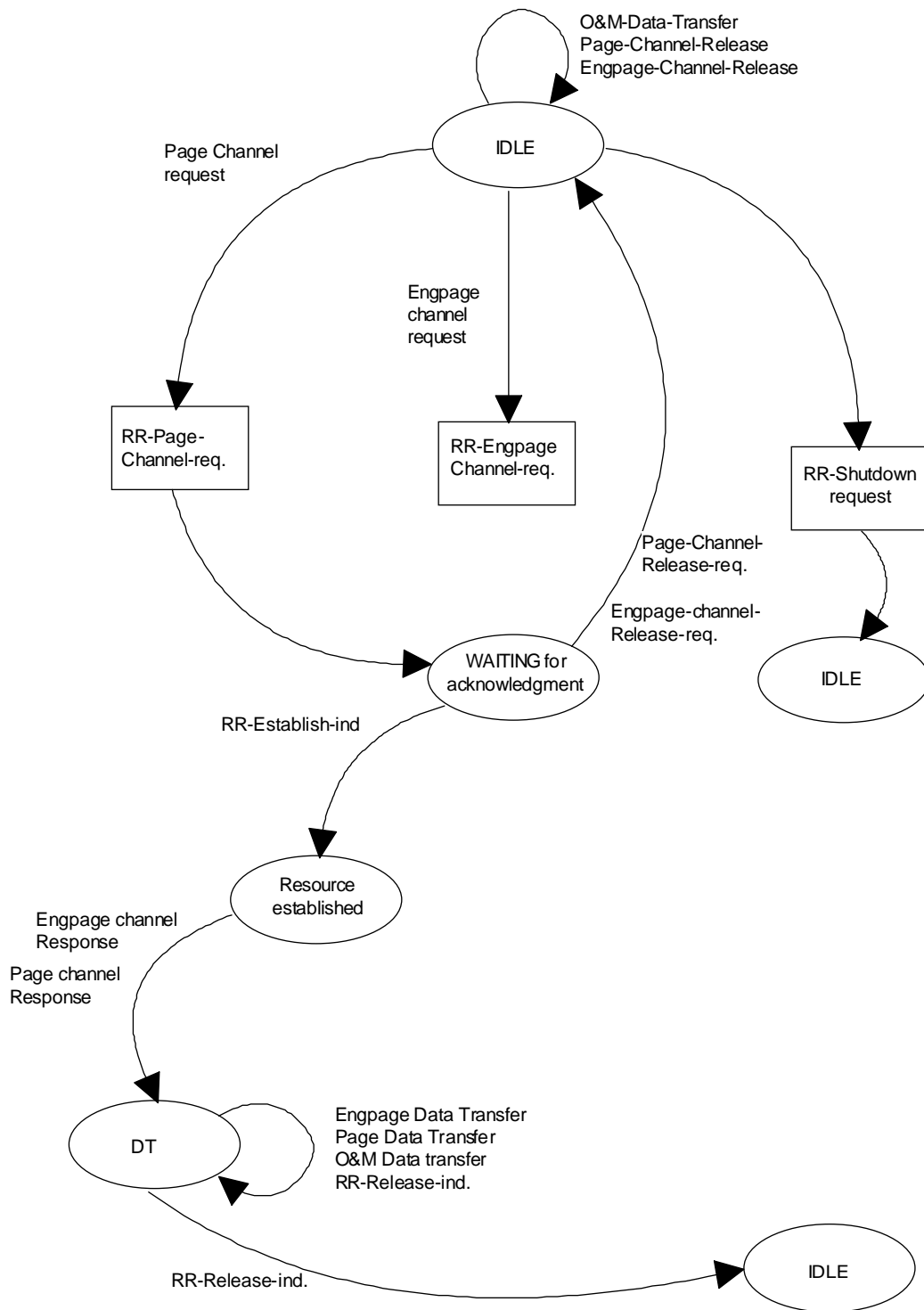


Figure 55: Overview MR management protocol GS side

10.11.6 Handling of error conditions

10.11.6.1 General

Detailed error handling procedures on the GSS side are implementation dependent, but must at least follow the procedures described below which are listed in order of precedence.

#### **10.11.6.2 Protocol discrimination error**

If the AS or the GSS receives a message with a protocol discriminator different from those specified in this specification, it may ignore the message.

NOTE: "Ignore" means to do nothing, as if the message had never been received.

#### **10.11.6.3 Message too short**

When a message is received that is too short to contain a complete message type information element, that message shall be ignored.

#### **10.11.6.4 Transaction identifier error**

##### **10.11.6.4.1 Call control**

The following procedures shall apply:

- whenever any message except SETUP, RELEASE COMPLETE or STATUS is received specifying a transaction identifier which is not recognized as relating to an active call or to call in progress, the receiving entity shall send a RELEASE COMPLETE message with cause #81 "invalid transaction identifier value" using the received transaction identifier value and shall remain in the "NULL" state;
- when a RELEASE COMPLETE message is received specifying a transaction identifier which is not recognized as relating to an active call or to call in progress, no action shall be taken;
- when a SETUP message is received specifying a transaction identifier which is recognized as relating to an active call or to a call in progress, this message shall be ignored;
- when a STATUS message is received specifying a transaction identifier which is not recognized as relating to an active call or to a call in progress, the procedures of subclause 10.11.4.5.2 shall apply.

##### **10.11.6.4.2 Radio resource**

Whenever a message is received in the AS specifying a transaction identifier which is not recognized as relating to an allocated resource, no action shall be taken.

##### **10.11.6.4.3 MR**

Whenever a message is received in the AS specifying a transaction identifier which is not recognized as relating to an allocated resource, no action shall be taken.

#### **10.11.6.5 Message type error**

##### **10.11.6.5.1 Call control**

If the AS receives a non-existent message type, a message not consistent with the Protocol Discriminator, not consistent with the direction or not consistent with the state, the AS shall ignore the message and shall return a STATUS with cause #98 "message not compatible with control state or non-existent or not implemented".

The GSS side shall follow the same procedure.

##### **10.11.6.5.2 Radio resource**

If a non-existent message type, a message not consistent with the Protocol Discriminator, not consistent with the direction or not consistent with the state, the AS shall ignore the message and send a STATUS message with either the cause:

- message type non-existent or not implemented; or
- message type non-compatible with control state or non existent or not implemented.

#### **10.11.6.5.3 MR**

If a non-existent message type, a message not consistent with the Protocol Discriminator, not consistent with the direction or not consistent with the state, the AS shall ignore the message and send a STATUS message with either the cause:

- message type non-existent or not implemented; or
- message type non-compatible with control state or non existent or not implemented.

#### **10.11.6.6 General information elements errors**

The general information elements error category includes:

- information element out of sequence;
- duplicated information element.

##### **10.11.6.6.1 Information element out of sequence**

In those cases where an out of sequence information element is detected, the procedure specified in subclause 10.11.6.7 shall be followed.

##### **10.11.6.6.2 Duplicated information element**

If a non-mandatory information element is repeated in a message in which reception of the information element is not permitted, only the contents of the information element appearing first shall be handled and all subsequent repetitions of the information element shall be ignored.

##### **10.11.6.7 Mandatory information element error**

This corresponds to either a missing mandatory information element or a mandatory information element content error. These cases are indistinguishable in this ETS.

##### **10.11.6.7.1 Call control**

When a message other than the messages listed below is received with mandatory information element errors, no action shall be taken on the message and no state change shall occur. A STATUS message shall be returned with cause #100 "invalid information element contents":

- when a SETUP or a RELEASE message is received with mandatory information element errors, a RELEASE COMPLETE message with cause #100 "invalid information element contents" shall be returned;
- when a DISCONNECT message is received with mandatory information element errors, a RELEASE message shall be returned with cause, #100 "invalid information element contents" and subclause 10.11.4.4 "call clearing" shall apply;
- a RELEASE COMPLETE message with mandatory information element errors shall be treated as a normal RELEASE COMPLETE message.

Information elements with a length exceeding the maximum length shall be treated as information element with content error.

#### 10.11.6.7.2 Radio resource

If the RRM receives a RESOURCE-ABORT-REQUEST message with a mandatory information element content error, the RRM shall release all existing resources and return to IDLE mode.

#### 10.11.6.8 Non-mandatory information element errors

This category includes:

- unrecognized information element;
- non-mandatory information element contents error.

##### 10.11.6.8.1 Unrecognized information element

###### 10.11.6.8.1.1 Call control

When a message is received which has one or more unrecognized information elements, the AS shall check whether any are encoded to indicate "comprehension required". If any unrecognized information element is encoded to indicate "comprehension required", then the procedures in subclause 10.11.6.7 shall be followed; i.e., as if a "missing mandatory information element" error condition had occurred. If all unrecognized information elements are not encoded to indicate "comprehension required", then the AS shall proceed as follows:

- action shall be taken on the message and those information elements which are recognized and have valid content. When the received message is other than DISCONNECT, RELEASE, RELEASE COMPLETE, a STATUS message shall be returned containing one cause information element.

NOTE: The discrimination for comprehension is to be provided.

The STATUS message shall indicate the call state in which the receiver detected the error. The cause information element shall contain cause #99 "information element non-existent or not implemented", and the diagnostic field, if present, shall contain the information element identifier for each information element which was unrecognized.

If a CC clearing message contains one or more unrecognized information elements, the AS shall act in the following manner:

- when a DISCONNECT message is received which has one or more unrecognized information elements, a RELEASE message with cause #99, "information element non-existent or not implemented," shall be returned. The Cause information element diagnostic field, if present, shall contain the information element identifier for each information element which was unrecognized;
- when a RELEASE message is received which has one or more unrecognized information elements, a RELEASE COMPLETE message with cause #99, "information element non-existent or not implemented," shall be returned. The Cause information element diagnostic field, if present, shall contain the information element identifier for each information element which was unrecognized;
- when a RELEASE COMPLETE message is received which has one or more unrecognized information elements, no action shall be taken on the unrecognized information.

NOTE: The diagnostic(s) of cause #99 facilitates the decision in selecting an appropriate recovery procedure at the reception of a STATUS message. Therefore, it is recommended to provide cause #99 with diagnostic(s) if a layer 3 entity expects the peer to take an appropriate action at the receipt of a STATUS message, although inclusion of diagnostic(s) is optional.

The GSS shall follow the same procedure.

#### **10.11.6.8.2 Non-mandatory information element content error**

##### **10.11.6.8.2.1 Call control**

When a message is received which has one or more non-mandatory information elements with invalid content, the procedure in subclause 10.11.6.7 shall be followed.

#### **10.11.7 Message functional definitions and contents**

This subclause provides an overview of the subclause 10.11 message structure, and highlights the functional definition and information content (i.e. semantics) of each message. Each definition includes:

- 1) a brief description of the message direction and use, including whether the message has:
  - local significance, i.e. relevant only on the originating or terminating access;
  - access significance, i.e. relevant in the originating and terminating access, but not in the network;
  - dual significance, i.e. relevant in either the originating or terminating access and in the network; or
  - global significance, i.e. relevant in the originating and terminating access and in the network.
- 2) a table listing the information elements in the order of their appearance in the message (mandatory before optional and for the latter in the same relative order for all message types). For each information element the table indicates:
  - the subclause of this ETS describing the information element;
  - the direction in which it may be sent; i.e., AS to GSS (as --> gss), GSS to AS (gss --> as), or both;
  - the type of the information element i.e. whether it is mandatory with fixed length (MF), mandatory with variable length (MV), optional with fixed length (OF) or optional with variable length (OV). For each optional information element a reference to a note is given. The note explains the circumstances under which the information element shall be included;
  - the length of the information element (or permissible range of lengths), in octets, where "?" denotes an undefined maximum length.

##### **10.11.7.1 Messages for RRM**

Table 23 summarizes the messages for RRM.

**Table 23: Messages for RRM**

Channel establishment messages:	Reference
ESTABLISH REQUEST	10.11.7.1.1
ESTABLISH CONFIRM	10.11.7.1.2
ESTABLISH REJECT	10.11.7.1.3
IDENTITY INDICATION	10.11.7.1.11
Handover messages:	Reference
HANDOVER COMMAND	10.11.7.1.4
HANDOVER REQUEST	10.11.7.1.5
HANDOVER REJECT	10.11.7.1.6
HANDOVER FAILURE	10.11.7.1.12
HANDOVER COMPLETE	10.11.7.1.13
Channel release messages:	Reference
RESOURCE RELEASE REQUEST	10.11.7.1.7
RESOURCE RELEASE CONFIRM	10.11.7.1.8
RESOURCE ABORT REQUEST	10.11.7.1.9
RESOURCE ABORT CONFIRM	10.11.7.1.10
System Information elements:	Reference
SYSTEM INFORMATION TYPE 1	10.11.7.1.14
SYSTEM INFORMATION TYPE 2	10.11.7.1.15
SYSTEM INFORMATION TYPE 3	10.11.7.1.16
SYSTEM INFORMATION TYPE 4	10.11.7.1.17
SYSTEM INFORMATION TYPE 5	10.11.7.1.18
SYSTEM INFORMATION TYPE 6	10.11.7.1.19
SYSTEM INFORMATION TYPE 7	10.11.7.1.20
SYSTEM INFORMATION TYPE 8	10.11.7.1.21
SYSTEM INFORMATION TYPE 9	10.11.7.1.21a
Status message:	Reference
STATUS	10.11.7.1.22

**10.11.7.1.1 Establish request**

This message shall be used for initial or additional request for radio resources. This assignment shall be initiated by the AS. See table 24.

The origin for a request shall be the AS.

Message type: ESTABLISH REQUEST  
 Significance: dual  
 Direction: AS to GSS

**Table 24: ESTABLISH REQUEST message content**

Information element	Reference	Direction	Type	Length
Protocol discriminator	10.11.8.2	as -> gss	MF	2
Transaction identifier	10.11.8.3	as -> gss	MF	
Message type	10.11.8.4	as -> gss	MF	1
Resource request	10.11.8.5.2.9	as -> gss	MF	
Traffic channel ID	10.11.8.5.2.14	as -> gss	MF	

**10.11.7.1.2 Establish confirm**

This message shall be used to confirm a resource request and to transmit the radio channel number and the allocated slot numbers to the AS. See table 25.

Message type: ESTABLISH CONFIRM  
 Significance: dual  
 Direction: GSS to AS



**Table 25: ESTABLISH CONFIRM message content**

Information element	Reference	Direction	Type	Length
Protocol discriminator	10.11.8.2	gss -> as	MF	2
Transaction identifier	10.11.8.3	gss -> as	MF	
Message type	10.11.8.4	gss -> as	MF	1
Radio channel number	10.11.8.5.2.8	gss -> as	MF	
Slot allocation	10.11.8.5.2.12	gss -> as	MF	2
Traffic channel ID	10.11.8.5.2.14	gss -> as	MF	1

**10.11.7.1.3 Establish reject**

This message shall be used to reject the resource request indicating the cause of the rejection. See table 26.

Message type: ESTABLISH REJECT  
Significance: dual  
Direction: GSS to AS

**Table 26: ESTABLISH REJECT message content**

Information element	Reference	Direction	Type	Length
Protocol discriminator	10.11.8.2	gss -> as	MF	2
Transaction identifier	10.11.8.3	gss -> as	MF	
Message type	10.11.8.4	gss -> as	MF	1
RR-Cause	10.11.8.5.2.2	gss -> as	MF	
Traffic channel ID	10.11.8.5.2.14	gss -> as	MF	1

**10.11.7.1.4 Handover command**

This message shall be used to start a handover process (changeover to the new GS or a different channel/slot configuration) in the AS. See table 27.

Message type: HANDOVER COMMAND  
Significance: dual  
Direction: GSS to AS

**Table 27: HANDOVER COMMAND message content**

Information element	Reference	Direction	Type	Length
Protocol discriminator	10.11.8.2	gss -> as	MF	2
Transaction identifier	10.11.8.3	gss -> as	MF	
Message type	10.11.8.4	gss -> as	MF	1
Radio channel number	10.11.8.5.2.8	gss -> as	MF	
Slot allocation	10.11.8.5.2.12	gss -> as	MF	2
GSIC new GS	10.11.8.5.2.15	gss -> as	MF	3

**10.11.7.1.5 Handover request**

This message shall be used by the AS to initiate the handover procedure. The AS shall transmit the GS identity (GSID) of the selected GS to the current GS. See table 28.

Message type: HANDOVER REQUEST  
Significance: dual  
Direction: AS to GSS

**Table 28: GSID (GS identity)**

Information element	Reference	Direction	Type	Length
Protocol discriminator	10.11.8.2	as -> gss	MF	2
Transaction identifier	10.11.8.3	as -> gss	MF	
Message type	10.11.8.4	as -> gss	MF	
GSIC	10.11.8.5.2.15	as -> gss	MF	3

**10.11.7.1.6 Handover reject**

The handover reject message shall be sent by the GS to reject or terminate a handover process requested by the AS. The reason for the reject shall be given in this message. See table 29.

Message type: HANDOVER REJECT  
Significance: dual  
Direction: GSS to AS

**Table 29: HANDOVER REJECT message content**

Information element	Reference	Direction	Type	Length
Protocol discriminator	10.11.8.2	gss -> as	MF	2
Transaction identifier	10.11.8.3	gss -> as	MF	
Message type	10.11.8.4	gss -> as	MF	
RR-Cause	10.11.8.5.2.2	gss -> as	MF	1

**10.11.7.1.7 Resource release request**

This message shall be used to release a currently used resource. This resource shall be identified by the protocol discriminator and the transaction identifier. See table 30.

Message type: RESOURCE RELEASE REQUEST  
Significance: dual  
Direction: AS to GSS

**Table 30: RESOURCE RELEASE REQUEST message content**

Information element	Reference	Direction	Type	Length
Protocol discriminator	10.11.8.2	as -> gss	MF	2
Transaction identifier	10.11.8.3	as -> gss	MF	
Message type	10.11.8.4	as -> gss	MF	
Traffic channel ID	10.11.8.5.2.14	as -> gss	MF	1

**10.11.7.1.8 Resource release confirm**

This message shall be used to confirm the release request. See table 31.

Message type: RESOURCE RELEASE CONFIRM  
Significance: dual  
Direction: GSS to AS

**Table 31: RESOURCE RELEASE CONFIRM message content**

Information element	Reference	Direction	Type	Length
Protocol discriminator	10.11.8.2	gss -> as	MF	2
Transaction identifier	10.11.8.3	gss -> as	MF	
Message type	10.11.8.4	gss -> as	MF	1
Traffic channel ID	10.11.8.5.2.14	gss -> as	MF	

**10.11.7.1.9 Resource abort request**

This message shall be used by the GS for a request to release all resources because of a failure in the GSS which could not be repaired. See table 32.

Message type: RESOURCE ABORT REQUEST  
Significance: dual  
Direction: GSS to AS

**Table 32: RESOURCE ABORT REQUEST message content**

Information element	Reference	Direction	Type	Length
Protocol discriminator	10.11.8.2	gss -> as	MF	2
Transaction identifier	10.11.8.3	gss -> as	MF	
Message type	10.11.8.4	gss -> as	MF	1
RR-Cause	10.11.8.5.2.2	gss -> as	MF	

**10.11.7.1.10 Resource abort confirm**

This message shall be used to confirm an abort of all currently used resources. See table 33.

Message type: RESOURCE ABORT CONFIRM  
Significance: dual  
Direction: AS to GSS

**Table 33: RESOURCE ABORT CONFIRM message content**

Information element	Reference	Direction	Type	Length
Protocol discriminator	10.11.8.2	as -> gss	MF	2
Transaction identifier	10.11.8.3	as -> gss	MF	
Message type	10.11.8.4	as -> gss	MF	1

**10.11.7.1.11 Identity indication**

This message shall transmit the aircraft termination equipment identity (ATEI) to the GS. See table 34.

Message type: IDENTITY INDICATION  
Significance: dual  
Direction: AS to GSS

**Table 34: IDENTITY INDICATION message content**

Information element	Reference	Direction	Type	Length
Protocol discriminator	10.11.8.2	as -> gss	MF	2
Transaction identifier	10.11.8.3	as -> gss	MF	
Message type	10.11.8.4	as -> gss	MF	4
ATEI	10.11.8.5.2.1	as -> gss	MF	
Relative eirp	10.11.8.5.2.10	as -> gss	MF	1

**10.11.7.1.12 Handover failure**

The handover failure message shall be sent after a successful reconnection to the old GS, to indicate the failure of handover in the AS. It shall terminate the handover procedure on the GS side. See table 35.

Message type: HANDOVER FAILURE  
 Significance: DUAL  
 Direction: AS to GSS

**Table 35: HANDOVER FAILURE message content**

Information element	Reference	Direction	Type	Length
Protocol discriminator	10.11.8.2	as -> gss	MF	2
Transaction identifier	10.11.8.3	as -> gss	MF	
Message type	10.11.8.4	as -> gss	MF	
RR-Cause	10.11.8.5.2.2	as -> gss	MF	1

**10.11.7.1.13 Handover complete**

The handover complete message shall be sent to indicate the successful case of handover to a new GS or channel/slot configuration. See table 36.

Message type: HANDOVER COMPLETE  
 Significance: dual  
 Direction: AS to GSS

**Table 36: HANDOVER COMPLETE message content**

Information element	Reference	Direction	Type	Length
Protocol discriminator	10.11.8.2	as -> gss	MF	2
Transaction identifier	10.11.8.3	as -> gss	MF	
Message type	10.11.8.4	as -> gss	MF	
RR-Cause	10.11.8.5.2.2	as -> gss	MF	1

**10.11.7.1.13a Group broadcast data transfer**

This message is used for the transport of group broadcast data from the TFTS network to one or more aircraft within coverage of the TFTS. The message format is shown in table 37.

Message type: Group broadcast data transfer  
 Significance: Local  
 Direction: GSS to AS

**Table 37: Group broadcast data transfer**

Information element	Reference	Direction	Type	Length
Message type	10.11.8.4	gss -> as	MF	1
Sequential message Number	10.11.8.5.2.19	gss -> as	MF	1
Group broadcast data	10.11.8.5.2.16	gss -> as	MF	8

**10.11.7.1.14 System Information type 1**

This message shall be used to have the actual date and time available, the latitude/longitude parameter to get the geographical position of the GS and the GSIC which identifies a GS in the TFTS network. See table 38.

Message type: SYSTEM INFORMATION TYPE 1  
Significance: dual  
Direction: GSS to AS

**Table 38: SYSTEM INFORMATION TYPE 1 message content**

Information element	Reference	Direction	Type	Length
Message type	10.11.8.4	gss -> as	MF	1
Time/lat/long	10.11.8.5.2.13	gss -> as	MF	6
GSIC	10.11.8.5.2.15	gss -> as	MF	3

**10.11.7.1.15 System Information type 2**

This message shall be used for cell management purposes. See table 39.

Message type: SYSTEM INFORMATION TYPE 2  
Significance: dual  
Direction: GSS to AS

**Table 39: SYSTEM INFORMATION TYPE 2 message content**

Information element	Reference	Direction	Type	Length
Message type	10.11.8.4	gss -> as	MF	1
Cell management param	10.11.8.5.2.3	gss -> as	MF	9

**10.11.7.1.16 System Information type 3**

This message shall be used to indicate the enroute primary frequencies. See table 40.

Message type: SYSTEM INFORMATION TYPE 3  
Significance: dual  
Direction: GSS to AS

**Table 40: SYSTEM INFORMATION TYPE 3 message content**

Information element	Reference	Direction	Type	Length
Message type	10.11.8.4	gss -> as	MF	1
ER Primary frequency	10.11.8.5.2.5	gss -> as	MF	9

**10.11.7.1.17 System Information type 4**

This message shall be used to indicate the ER-primary frequencies (continued from SYSTEM INFORMATION TYPE 3) and the primary frequencies for INT and AP stations. See table 41.

Message type: SYSTEM INFORMATION TYPE 4  
Significance: dual  
Direction: GSS to AS

**Table 41: SYSTEM INFORMATION TYPE 4 message content**

Information element	Reference	Direction	Type	Length
Message type	10.11.8.4	gss -> as	MF	1
Primary frequency	10.11.8.5.2.7	gss -> as	MF	9

**10.11.7.1.18 System Information type 5**

This message shall be used to command a close down of a specific AS. See table 42.

The message format given in table 42 shall be used on the BCCH(D).

Message type: SYSTEM INFORMATION TYPE 5  
Significance: dual  
Direction: GSS to AS

**Table 42: SYSTEM INFORMATION TYPE 5 message content**

Information element	Reference	Direction	Type	Length
Message type	10.11.8.4	gss -> as	MF	1
ATEI	10.11.8.5.2.1	gss -> as	MF	4
Shutdown duration	10.11.8.5.2.11	gss -> as	MF	5

If the message is sent on the DCCH the format shown in table 43 shall be used.

Message type: SYSTEM INFORMATION TYPE 5  
Significance: dual  
Direction: GSS to AS

**Table 43: SYSTEM INFORMATION TYPE 5 message content (used on the DCCH)**

Information element	Reference	Direction	Type	Length
Protocol discriminator	10.11.8.2	gss -> as	MF	2
Transaction identifier	10.11.8.3	gss -> as	MF	
Message type	10.11.8.4	gss -> as	MF	4
ATEI	10.11.8.5.2.1	gss -> as	MF	
Shutdown duration	10.11.8.5.2.11	gss -> as	MF	1

**10.11.7.1.19 System Information type 6**

This message shall be used for paging purposes from subscribers of a public network connected to the TFTS. See table 44.

Message type: SYSTEM INFORMATION TYPE 6  
Significance: dual  
Direction: GSS to AS

**Table 44: SYSTEM INFORMATION TYPE 6 message content**

Information element	Reference	Direction	Type	Length
Message type	10.11.8.4	gss -> as	MF	1
ATEI	10.11.8.5.2.1	gss -> as	MF	4
Page	10.11.8.5.2.6	gss -> as	MF	4
Resource request	10.11.8.5.2.9	gss -> as	MF	1

NOTE: This resource request is currently fixed to 9,6 kbit/s signalling.

**10.11.7.1.20 System Information type 7**

This message shall be used for engineering purposes e.g. test of TFTS AS equipment. See table 45.

Message type: SYSTEM INFORMATION TYPE 7  
Significance: dual  
Direction: GSS to AS

**Table 45: SYSTEM INFORMATION TYPE 7 message content**

Information element	Reference	Direction	Type	Length
Message type	10.11.8.4	gss -> as	MF	1
ATEI	10.11.8.5.2.1	gss -> as	MF	4
Engineering Page	10.11.8.5.2.4	gss -> as	MF	4
Resource request	10.11.8.5.2.9	gss -> as	MF	1

NOTE: This resource request is currently fixed to 9,6 kbit/s signalling.

**10.11.7.1.21 System Information type 8**

This message shall be sent if no system information type 5, 6 or 7 needs to be sent. The information field of this message (octet 2 to octet 10) shall contain dummy bits all set to 0. See table 46.

Message type: SYSTEM INFORMATION TYPE 8  
Significance: dual  
Direction: GSS to AS

**Table 46: SYSTEM INFORMATION TYPE 8 (dummy message) message content**

Information element	Reference	Direction	Type	Length
Message type	10.11.8.4	gss -> as	MF	1
Dummy field	no ref	gss -> as	MF	9

**10.11.7.1.21a System Information type 9**

This message is used to indicate via the BCCH(D) to ASs that group broadcast data is being transmitted on an identified set of slots on the access carrier. The message format is shown in table 47.

Message type: SYSTEM INFORMATION TYPE 9  
Significance: local  
Direction: GSS to AS

**Table 47: SYSTEM INFORMATION TYPE 9 message content**

Information element	Reference	Direction	Type	Length
Message type	10.11.8.4	gss -> as	MF	1
Group broadcast channel reference	10.11.8.5.4.4	gss -> as	MF	2
Slot allocation	10.11.8.5.2.12	gss -> as	MF	2
Group broadcast data message count	10.11.8.5.2.18	gss -> as	MF	1
Aircraft group	10.11.8.5.2.17	gss -> as	MF	4

**10.11.7.1.22 Status**

The Status message shall be sent by the AS or the GSS at any time during an existing connection to report certain error conditions listed in subclause 10.11.6. See table 48.

Message type: STATUS  
Significance: dual  
Direction: both

**Table 48: STATUS message content**

Information element	Reference	Direction	Type	Length
Protocol discriminator	10.11.8.2	both	MF	2
Transaction identifier	10.11.8.3	both	MF	
Message type	10.11.8.4	both	MF	1
RR-Cause	10.11.8.5.2.2	both	MF	

**10.11.7.2 Messages for circuit-mode connections CC**

Table 49 summarizes the messages for circuit-mode connections CC.

**Table 49: Messages for circuit-mode connections CC**

Call establishment messages:	Reference
ALERTING	10.11.7.2.1
CALL PROCEEDING	10.11.7.2.2
CONNECT	10.11.7.2.3
PROGRESS	10.11.7.2.6
SETUP	10.11.7.2.9
Call clearing messages:	Reference
DISCONNECT	10.11.7.2.4
RELEASE	10.11.7.2.7
RELEASE COMPLETE	10.11.7.2.8
Miscellaneous messages:	Reference
NOTIFY	10.11.7.2.5
SEND DTMF (note)	10.11.7.2.10
SEND DTMF ACKNOWLEDGE (note)	10.11.7.2.11
SEND DTMF REJECT (note)	10.11.7.2.12
STATUS	10.11.7.2.13
STATUS ENQUIRY	10.11.7.2.14
NOTE:	Not supported by CCITT Recommendation Q.931.



**10.11.7.2.1 Alerting**

This message shall be sent by the GSS to the calling AS to indicate that the called user alerting has been initiated. See table 50.

Message type: ALERTING  
Significance: global  
Direction: GSS to AS

**Table 50: ALERTING message content**

Information element	Reference	Direction	Type	Length
Protocol discriminator	10.11.8.2	gss -> as	MF	2
Transaction identifier	10.11.8.3	gss -> as	MF	
Message type	10.11.8.4	gss -> as	MF	
Progress indicator (note)	10.11.8.5.3.12	gss -> as	OV	4

NOTE: Included in the event of interworking or in connection with the provision of in-band information/patterns.

**10.11.7.2.2 Call proceeding**

This message shall be sent by the GSS to the calling AS to indicate that the requested call establishment information has been received, and no more call establishment information will be accepted. See table 51.

Message type: CALL PROCEEDING  
Significance: local  
Direction: GSS to AS

**Table 51: CALL PROCEEDING message content**

Information element	Reference	Direction	Type	Length
Protocol discriminator	10.11.8.2	gss -> as	MF	1
Transaction identifier	10.11.8.3	gss -> as	MF	2
Message type	10.11.8.4	gss -> as	MF	1
Repeat indicator 1,2)	10.11.8.5.3.14	gss -> as	OF	1
Bearer capabilities 2)	10.11.8.5.3.2	gss -> as	OV	3
Progress indicator 3)	10.11.8.5.3.12	gss -> as	OV	4
NOTE 1: Included if the AS sent two bearer capabilities and at least presented a choice.				
NOTE 2: Included if the GSS has to specify the connection element.				
NOTE 3: Included in the event of interworking.				

**10.11.7.2.3 Connect**

This message shall be sent by the GSS to the calling AS to indicate call acceptance by the called user. See table 52.

Message type: CONNECT  
Significance: global  
Direction: GSS to AS

**Table 52: CONNECT message content**

Information element	Reference	Direction	Type	Length
Protocol discriminator	10.11.8.2	gss -> as	MF	 2
Transaction identifier	10.11.8.3	gss -> as	MF	
Message type	10.11.8.4	gss -> as	MF	
Progress indicator (note)	10.11.8.5.3.12	gss -> as	OV	4
NOTE: Included in the event of interworking or in connection with provision of in-band information/patterns.				

**10.11.7.2.4 Disconnect**

This message shall be sent by the AS to request the GSS to clear an end-to-end connection or shall be sent by the GSS to indicate that the end-to-end connection is cleared. See table 53.

Message type: DISCONNECT  
Significance: global  
Direction: both

**Table 53: DISCONNECT message content**

Information element	Reference	Direction	Type	Length
Protocol discriminator	10.11.8.2	both	MF	 2
Transaction identifier	10.11.8.3	both	MF	
Message type	10.11.8.4	both	MF	
Cause	10.11.8.5.3.6	both	MV	3 - 31
Progress indicator (note)	10.11.8.5.3.12	gss -> as	OV	4

NOTE: Included by the GSS if in-band tones are provided.

**10.11.7.2.5 Notify**

This message shall be sent either from the AS or from the GSS to indicate information pertaining to a call, such as user suspended. See table 54.

Message type: NOTIFY  
Significance: access  
Direction: both

**Table 54: NOTIFY message content**

Information element	Reference	Direction	Type	Length
Protocol discriminator	10.11.8.2	both	MF	2
Transaction identifier	10.11.8.3	both	MF	
Message type	10.11.8.4	both	MF	1
Notification indicator	10.11.8.5.3.11	both	MF	

**10.11.7.2.6 Progress**

This message shall be sent from the GSS to the AS to indicate the progress of a call in the event of interworking or in connection with the provision of in-band information/patterns. See table 55.

Message type: PROGRESS  
Significance: global  
Direction: GSS to AS

**Table 55: PROGRESS message content**

Information element	Reference	Direction	Type	Length
Protocol discriminator	10.11.8.2	gss -> as	MF	2
Transaction identifier	10.11.8.3	gss -> as	MF	
Message type	10.11.8.4	gss -> as	MF	3
Progress indicator	10.11.8.5.3.12	gss -> as	MV	

**10.11.7.2.7 Release**

This message shall be sent, from either the AS or the GSS, to indicate that the equipment sending the message intends to release the transaction identifier, and that the receiving equipment should release the transaction identifier after sending RELEASE COMPLETE. See table 56.

Message type: RELEASE  
Significance: local 1)  
Direction: both

**Table 56: RELEASE message content**

Information element	Reference	Direction	Type	Length
Protocol discriminator	10.11.8.2	both	MF	2
Transaction identifier	10.11.8.3	both	MF	
Message type	10.11.8.4	both	MF	4 - 32
Cause 2)	10.11.8.5.3.6	both	OV	

NOTE 1: This message has local significance; however, it may carry information of global significance when used as the first call clearing message.

NOTE 2: Mandatory in the first call clearing message including when the RELEASE message is sent as a result of an error handling condition.

**10.11.7.2.8 Release complete**

This message shall be sent, from either the AS or the GSS, to indicate that the equipment sending the message has released the transaction identifier and the receiving equipment shall release the transaction identifier. See table 57.

Message type: RELEASE COMPLETE  
 Significance: local 1)  
 Direction: both

**Table 57: RELEASE COMPLETE message content**

Information element	Reference	Direction	Type	Length
Protocol discriminator	10.11.8.2	both	MF	 2   4 - 32
Transaction identifier	10.11.8.3	both	MF	
Message type	10.11.8.4	both	MF	
Cause 2)	10.11.8.5.3.6	both	OV	
NOTE 1: This message has local significance; however it may carry information of global significance when used as the first call clearing message.				
NOTE 2: Mandatory in the first call clearing message, including when the RELEASE COMPLETE message is sent as a result of an error handling condition.				

10.11.7.2.9 Setup

This message shall be sent, from the AS to initiate call establishment. See table 58.

Message type: SETUP  
Significance: global  
Direction: AS to GSS

Table 58: SETUP message content

Information element	Reference	Direction	Type	Length
Protocol discriminator	10.11.8.2	as -> gss	MF	1
Transaction identifier	10.11.8.3	as -> gss	MF	2
Message type	10.11.8.4	as -> gss	MF	1
Connection type	10.11.8.5.3.15	as -> gss	MF	1
Bearer capabilities	10.11.8.5.3.2	as -> gss	MV	3
Called party BCD no. 2	10.11.8.5.3.4	as -> gss	MV	2-13
Called party subaddress 3	10.11.8.5.3.5	as -> gss	OV	2-23
Aircraft information 4	10.11.8.5.3.1	as -> gss	OF	10
Low layer compatibility 5	10.11.8.5.3.10	as -> gss	OV	3-15
High layer compatibility	10.11.8.5.3.8	as -> gss	OV	4-5
Credit card information 7	10.11.8.5.3.7	as -> gss	OV	3-40
NOTE 1: The reconnection indicator is included if the call is a re-establishment of a previous call.				
NOTE 2: The called party BCD number shall always be included in the AS to GSS direction.				
NOTE 3: Included in the AS-to-GSS direction when the calling user wants to indicate the called party subaddress.				
NOTE 4: Included by the calling AS if aircraft information is available.				
NOTE 5: Included in the AS-to-GSS direction when the calling AS wants to pass low layer compatibility information to the called user.				
NOTE 6: Included in the AS-to-GSS direction when the calling AS wants to pass high layer compatibility information to the called user.				
NOTE 7: Included if credit card information data is going to be transmitted to the GSS for charging.				
NOTE 8: Bearer capability, low layer compatibility, and high layer compatibility information elements may be used to describe a CCITT telecommunication service, if appropriate.				

**10.11.7.2.10 Send DTMF**

This message shall be sent by the AS to the GSS and contains the digit the GSS should re-convert back into a DTMF tone which shall be then applied towards the remote user. See table 59.

Message type: SEND DTMF  
Significance: local  
Direction: AS to GSS

**Table 59: SEND DTMF message content**

Information element	Reference	Direction	Type	Length
Protocol discriminator	10.11.8.2	as -> gss	MF	 2
Transaction identifier	10.11.8.3	as -> gss	MF	
Message type	10.11.8.4	as -> gss	MF	
Keypad facility	10.11.8.5.3.9	as -> gss	MF	
NOTE: The keypad information element will contain only 1 DTMF digit and has, therefore, a fixed length of 2 octets.				

**10.11.7.2.11 Send DTMF acknowledge**

This message shall be sent by the GSS to the AS to indicate the successful initiation of the action requested by the SEND DTMF message (conversion of the digit contained in this message into a DTMF tone). See table 60.

Message type: SEND DTMF ACKNOWLEDGE  
Significance: local  
Direction: GSS to AS

**Table 60: SEND DTMF ACKNOWLEDGE message content**

Information element	Reference	Direction	Type	Length
Protocol discriminator	10.11.8.2	gss -> as	MF	 2
Transaction identifier	10.11.8.3	gss -> as	MF	
Message type	10.11.8.4	gss -> as	MF	
Keypad facility (note)	10.11.8.5.3.9	gss -> as	MV	
NOTE: This information element contains the digit corresponding to the DTMF tone that the GSS applies towards the remote user.				

**10.11.7.2.12 Send DTMF reject**

This message shall be sent by the GSS to the AS, if the GSS can not accept the SEND DTMF message. See table 61.

Message type: SEND DTMF REJECT  
Significance: local  
Direction: GSS to AS

**Table 61: SEND DTMF REJECT message content**

Information element	Reference	Direction	Type	Length
Protocol discriminator	10.11.8.2	gss -> as	MF	 2
Transaction identifier	10.11.8.3	gss -> as	MF	
Message type	10.11.8.4	gss -> as	MF	
Cause	10.11.8.5.3.6	gss -> as	MV	

**10.11.7.2.13 Status**

This message shall be sent by the AS or the GSS at any time during a call to report certain error conditions listed in subclause 10.11.6. See table 62.

Message type: STATUS  
Significance: local  
Direction: both

**Table 62: STATUS message content**

Information element	Reference	Direction	Type	Length
Protocol discriminator	10.11.8.2	both	MF	 2
Transaction identifier	10.11.8.3	both	MF	
Message type	10.11.8.4	both	MF	
Cause	10.11.8.5.3.6	both	MV	
Call state	10.11.8.5.3.3	both	MF	1

**10.11.7.2.14 Status enquiry**

This message shall be sent by the AS or the GSS at any time to solicit a STATUS message from the peer layer 3 entity. Sending of STATUS message in response to a STATUS ENQUIRY message shall be mandatory. See table 63.

Message type: STATUS ENQUIRY  
Significance: local  
Direction: both

**Table 63: STATUS ENQUIRY message content**

Information element	Reference	Direction	Type	Length
Protocol discriminator	10.11.8.2	both	MF	 2
Transaction identifier	10.11.8.3	both	MF	
Message type	10.11.8.4	both	MF	

**10.11.7.3 Messages for MR management**

Table 64 summarizes the messages used by the MR management.

**Table 64: Messages used by MR management**

MR management messages	Reference
ENGPAGE CHANNEL RESPONSE	10.11.7.3.1
ENGPAGE DATA TRANSFER	10.11.7.3.2
ENGPAGE CHANNEL RELEASE	10.11.7.3.3
OM DATA TRANSFER	10.11.7.3.4
PAGE CHANNEL RESPONSE	10.11.7.3.5
PAGE DATA TRANSFER	10.11.7.3.6
PAGE CHANNEL RELEASE	10.11.7.3.7
STATUS	10.11.7.3.8

**10.11.7.3.1 ENGPAGE channel response**

This message shall be sent by the AS to the GS in answer to an engineering page request.

Message type: ENGPAGE CHANNEL RESPONSE  
Significance: dual  
Direction: AS to GSS

**Table 65: ENGPAGE channel response message content**

Information element	Reference	Direction	Type	Length
Protocol discriminator	10.11.8.2	as -> gss	MF	 2
Transaction identifier	10.11.8.3	as -> gss	MF	
Message type	10.11.8.4	as -> gss	MF	
Eng channel reference	10.11.8.5.4.1	as -> gss	MF	

**10.11.7.3.2 ENGPAGE data transfer**

This message shall be sent by both sides to transfer data for engineering purposes between AS and GS.

Message type: ENGPAGE DATA TRANSFER  
Significance: dual  
Direction: both

**Table 66: ENGPAGE data transfer message content**

Information element	Reference	Direction	Type	Length
Protocol discriminator	10.11.8.2	both	MF	 2
Transaction identifier	10.11.8.3	both	MF	
Message type	10.11.8.4	both	MF	
ENG channel ref	10.11.8.5.4.1	both	MF	
Data information	10.11.8.5.4.3	both	MV	2-241



**10.11.7.3.3      ENGPAGE channel release**

This message shall be sent by the AS side or GS side to release all resources associated with the ENGPAGE channel.

Message type:    ENGPAGE CHANNEL RELEASE  
Significance:    dual  
Direction:        both

**Table 67: ENGPAGE channel release message content**

Information element	Reference	Direction	Type	Length
Protocol discriminator	10.11.8.2	both	MF	2
Transaction identifier	10.11.8.3	both	MF	
Message type	10.11.8.4	both	MF	
ENG channel ref	10.11.8.5.4.1	both	MF	2
MR cause	10.11.8.5.4.5	both	MF	1

**10.11.7.3.4      OM data transfer**

This message shall be sent by the AS to the GS to transfer OM data.

Message type:    OM DATA TRANSFER  
Significance:    dual  
Direction:        both

**Table 68: OM data transfer message content**

Information element	Reference	Direction	Type	Length
Protocol discriminator	10.11.8.2	both	MF	2
Transaction identifier	10.11.8.3	both	MF	
Message type	10.11.8.4	both	MF	
ATEI	10.11.8.5.4.2	both	MF	4
Data information	10.11.8.5.4.3	both	MV	2-241

**10.11.7.3.5      PAGE channel response**

This message shall be sent by the AS to answer a paging request.

Message type:    PAGE CHANNEL RESPONSE  
Significance:    dual  
Direction:        AS to GSS

**Table 69: PAGE channel response message content**

Information element	Reference	Direction	Type	Length
Protocol discriminator	10.11.8.2	as -> gss	MF	2
Transaction identifier	10.11.8.3	as -> gss	MF	
Message type	10.11.8.4	as -> gss	MF	
Page channel ref	10.11.8.5.4.4	as -> gss	MF	2

**10.11.7.3.6 PAGE data transfer**

This message shall be sent by both sides to transfer data for paging purposes between AS and GS.

Message type: PAGE DATA TRANSFER  
Significance: dual  
Direction: both

**Table 70: PAGE data transfer message content**

Information element	Reference	Direction	Type	Length
Protocol discriminator	10.11.8.2	both	MF	1
Transaction identifier	10.11.8.3	both	MF	2
Message type	10.11.8.4	both	MF	1
Page channel ref	10.11.8.5.4.4	both	MF	2
Data information	10.11.8.5.4.2	both	MV	2-241

**10.11.7.3.7 PAGE channel release**

This message shall be sent by the AS side to GS side to release all resources associated with the paging channel.

Message type: PAGE CHANNEL RELEASE  
Significance: dual  
Direction: both

**Table 71: PAGE channel release message content**

Information element	Reference	Direction	Type	Length
Protocol discriminator	10.11.8.2	both	MF	1
Transaction identifier	10.11.8.3	both	MF	2
Message type	10.11.8.4	both	MF	1
Page channel ref	10.11.8.5.4.4	both	MF	2
MR cause	10.11.8.5.4.5	both	MF	1

**10.11.7.3.8 Status**

The Status message shall be sent by the AS or the GSS at any time during an existing connection to report certain error conditions listed in subclause 10.11.6. See table 69.

Message type: STATUS  
Significance: dual  
Direction: both

**Table 72: STATUS message content**

Information element	Reference	Direction	Type	Length
Protocol discriminator	10.11.8.2	both	MF	1
Transaction identifier	10.11.8.3	both	MF	2
Message type	10.11.8.4	both	MF	1
MR cause	10.11.8.5.4.5	both	MF	1

**10.11.8 General message format and information elements coding**

The figures and text in this subclause describe message contents. Within each octet, the bit designated "bit 1" shall be transmitted first, followed by bits 2, 3, 4, etc. Similarly, the octet shown at the top of each figure shall be sent first.

**10.11.8.1 Overview**

Within this protocol, every message (except for messages sent on the BCCH(D)) shall consist of the following parts:

- protocol discriminator;
- transaction identifier;
- message type;
- other information elements, as required.

Because of the unidirectional nature link of the BCCH(D) the layer 2 header (2 octets) and octet 2 of the layer 3 header (see subclause 10.11.8.5) shall not be used for BCCH(D) data. Therefore the BCCH(D) messages shall have a fixed length of 10 octets with a data field of 9 octets.

NOTE: For messages sent on the BCCH(D) the RR management sub-layer (at the AS side) adds the protocol discriminator and transaction identifier when passing a message to the MR management sub-layer.

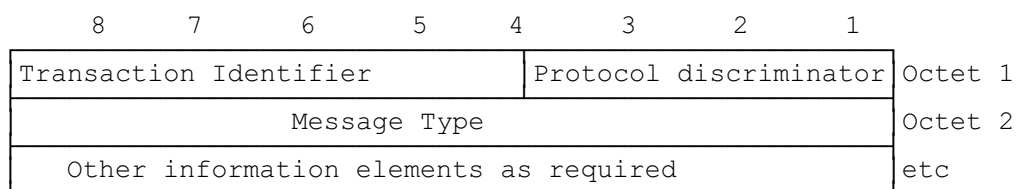
This organization is illustrated in the example shown in figure 56.

All equipment shall ignore any extra information, present in a message, which is not required for the proper operation of that equipment.

Unless specified otherwise, a particular information element may be present only once in a given message.

The term "default" implies that the value defined shall be used in the absence of any assignment, or the negotiation of alternative values.

When a field extends over more than one octet, the order of bit values shall progressively decrease as the octet number increases. The least significant bit of the field shall be represented by the lowest numbered bit of the highest- numbered octet of the field.



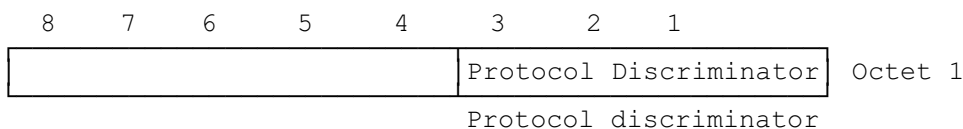
**Figure 56: General message organization example**

**10.11.8.2 Protocol discriminator**

The purpose of the protocol discriminator shall be to distinguish between messages belonging to the following procedures:

- radio resources management;
- CC;
- MR;
- other signalling procedures.

The protocol discriminator shall be the first part of every message and occupies the first three bits of the first octet in a message. It shall be coded according to figure 57.



**Figure 57: Protocol discriminator**

The protocol discriminator value shall be taken from table 73.

**Table 73: Protocol discriminator**

bits	3	2	1	
	0	0	0	Radio resource management messages
	0	0	1	Call control messages
	0	1	0	MR messages
	1	1	1	Test procedures messages

All other values are reserved

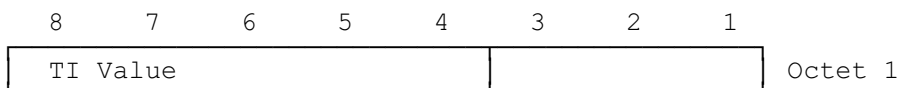
**10.11.8.3 Transaction identifier**

The purpose of the Transaction identifier (TI) shall be to distinguish multiple parallel activities (transactions) within one AS. The TI shall be equivalent to the call reference defined in CCITT Recommendation Q.931. Radio resource management shall use the predefined transaction identifier value 0. MR messages shall use the transaction identifier value 0 for OM purposes and the assigned transaction identifiers for the PAGE and ENGPAGE services.

The transaction identifier shall be the second part of every message. The transaction identifier shall be coded as shown in figure 58 and table 74.

The TI value shall occupy bits 4 - 8 of the first octet.

At the beginning of a transaction a free TI value shall be chosen and assigned to this transaction. It shall then remain fixed for the lifetime of the transaction. After a transaction ends and the used radio resources are released, the associated TI value shall be freed and may be reassigned to a later transaction.



**Figure 58: Transaction identifier**

**Table 74: Transaction identifier**

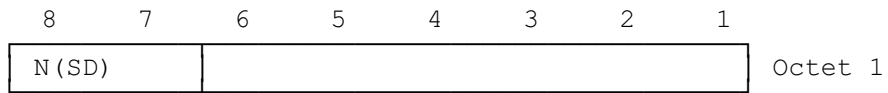
TI value (octet 1)					
Bits					
8	7	6	5	4	TI value
0	0	0	0	0	0
0	0	0	0	1	1
0	0	0	1	0	2
0	0	0	1	1	3
0	0	1	0	0	4
0	0	1	0	1	5
0	0	1	1	0	6
.	.	.	.	.	.
.	.	.	.	.	.
1	1	1	1	1	31

**10.11.8.4 Message type**

The purpose of the message type shall be to identify the function of the message being sent.

The message type shall be the third part of every message. The message type shall be coded as shown in figure 59 and tables 75 to 77.

Bit 7 and 8 in the CM-messages shall be sent from the AS and shall be reserved for the send sequence number N(SD) (see subclause 10.11.2.4.1). In all other messages bit 7 and 8 shall be set to "0".



**Figure 59: Message type**

Messages with different protocol discriminators are permitted to have the same message type i.e. the function of a message shall be determined by the protocol discriminator and the message type together.

**Table 75: Message types for RRM**

8	7	6	5	4	3	2	1	
0	0	1	1	-	-	-	-	Channel establishment messages:
				1	0	1	1	ESTABLISH REQUEST
				1	1	1	1	ESTABLISH CONFIRM
				1	0	0	1	ESTABLISH REJECT
				1	0	1	0	IDENTITY INDICATION
0	0	1	0	-	-	-	-	Handover messages:
				1	1	1	0	HANDOVER COMMAND
				1	0	0	1	HANDOVER REQUEST
				1	1	0	0	HANDOVER REJECT
				1	0	1	0	HANDOVER FAILURE
				1	0	1	1	HANDOVER COMPLETE
0	0	0	1	-	-	-	-	Channel release messages:
				0	0	1	1	RESOURCE RELEASE REQUEST
				0	1	1	1	RESOURCE RELEASE CONFIRM
0	0	0	1	1	0	0	0	RESOURCE ABORT REQUEST
0	0	0	1	1	0	0	1	RESOURCE ABORT CONFIRM
0	0	0	0	-	-	-	-	System Information elements:
				0	0	0	1	SYSTEM INFORMATION TYPE 1
				0	0	1	0	SYSTEM INFORMATION TYPE 2
				0	0	1	1	SYSTEM INFORMATION TYPE 3
				0	1	0	0	SYSTEM INFORMATION TYPE 4
				0	1	0	1	SYSTEM INFORMATION TYPE 5
				0	1	1	0	SYSTEM INFORMATION TYPE 6
				0	1	1	1	SYSTEM INFORMATION TYPE 7
				1	0	0	0	SYSTEM INFORMATION TYPE 8
				1	0	0	1	SYSTEM INFORMATION TYPE 9
0	0	1	1	0	0	0	0	RR-STATUS

**Table 76: Message types for CC**

8 7 6 5 4 3 2 1	
x x 0 0 - - - -	Call establishment messages:
0 0 0 1	- ALERTING
0 0 1 0	- CALL PROCEEDING
0 1 1 1	- CONNECT
0 0 1 1	- PROGRESS
0 1 0 1	- SETUP
x x 1 0 - - - -	Call clearing messages:
0 1 0 1	- DISCONNECT
1 1 0 1	- RELEASE
1 0 1 0	- RELEASE COMPLETE
x x 1 1 - - - -	Miscellaneous messages:
1 1 1 0	- NOTIFY
1 1 0 1	- STATUS
0 1 0 0	- STATUS ENQUIRY
0 1 0 1	- SEND DTMF
0 1 1 0	- SEND DTMF ACKNOWLEDGE
0 1 1 1	- SEND DTMF REJECT
All other values are reserved	
NOTE: Bits 7-8 shall be reserved for the send sequence number in messages sent from the AS. In messages sent from the network, bits 7-8 shall be coded with "0 0".	

**Table 77: Message types for MR management**

8 7 6 5 4 3 2 1	
x x 0 0 0 1 0 1	ENGPAGE CHANNEL RESPONSE
x x 0 0 0 1 1 0	ENGPAGE DATA TRANSFER
x x 0 0 0 1 1 1	ENGPAGE CHANNEL RELEASE
x x 0 0 1 0 0 0	OM DATA TRANSFER
x x 0 1 0 0 0 1	PAGE CHANNEL RESPONSE
x x 0 1 0 0 1 0	PAGE DATA TRANSFER
x x 0 1 0 0 1 1	PAGE CHANNEL RELEASE
x x 1 0 0 0 0 0	MR-STATUS
NOTE: Bit 7-8 shall be reserved for the send sequence number in messages sent from the AS. In messages sent from the network, bits 7-8 shall be coded with "0 0".	

**10.11.8.5 Other information elements**

When a message contains other information elements these shall be split into two different kinds for that message:

- information elements which are mandatory for the message;
- information elements which are optional for the message.

Possible mandatory information elements shall be sent before possible optional information elements. This organization is shown in figure 60.

Transaction identifier	Protocol discriminator	Octet 1
Message type		Octet 2
Other information elements which are mandatory		etc.
Other information elements which are optional		etc.

**Figure 60: Organization of other information elements**

When an information element which is optional for a given message is contained in the message it shall be identified by means of an information element identifier.

An information element which is mandatory for a given message shall not be identified by means of an information element identifier, as the presence and the order of the mandatory information elements are unambiguously determined by the protocol discriminator and the message type.

An information element may be mandatory for some messages and optional for other messages i.e. information elements shall contain the information element identifier in their definition. When an information element is mandatory for a message the information element identifier shall be stripped off the information element in that message.

Two main categories of information elements are defined:

- information elements with fixed length;
- information elements with variable length.

An information element with variable length shall be provided with a length indicator of one octet which shall determine the length of content of that information element. It shall be the binary coding of the number of octets of content with bit 1 as the least significant bit.

In a message, the length of content of a mandatory information element with fixed length shall be determined by the protocol discriminator and the message type of that message.

In a message, the length of content of a mandatory information element with variable length shall be determined by the length indicator which shall be the first octet of the information element. In a message, the length of content of an optional information element with fixed length shall be determined by the information element identifier.

In a message, the length of content of an optional information element with variable length shall be determined by the length indicator which shall be the second octet of the information element.

Four types of information elements are defined:

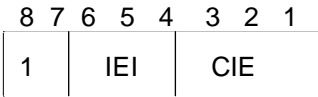
- information elements with 1/2 octet of content (type 1);
- information elements with 0 octets of content (type 2) (note);
- information elements with fixed length and at least one octet of content (type 3);
- information elements with variable length (type 4).

NOTE: A type 2 information element cannot be mandatory in a message.

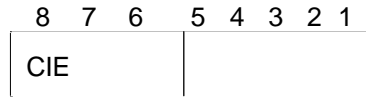
Type 1 information elements shall provide the information element identifier in bit positions 7, 6, 5. The value "0 1 0" in these bit positions shall be reserved for type 2 information elements which together with this shall provide the information element identifier in bit positions 4, 3, 2, 1. Type 3 and 4 information elements shall provide the information element identifier in bit positions 7, 6, 5, 4, 3, 2, 1 in the first octet.

These information elements are shown in figures 61 to 68 for both the case where the information element is optional in a message and mandatory in a message. In the mentioned figures IEI shall be used as an abbreviation for Information Element Identifier, CIE as an abbreviation for Content of Information Element and LI as an abbreviation for Length Indicator.

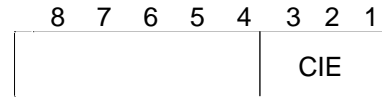
Type 1 Information elements with 1/2 octet of content



**Figure 61:**  
 The information element is optional

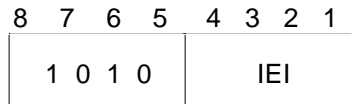


**Figure 62:**  
 The information element is mandatory



**Figure 63:**  
 The information element is mandatory

Type 2 Information elements with 0 octet of content



**Figure 64: The information element is optional**

Type 3 Information elements with fixed length and at least one octet of content



**Figure 65:**  
 The information element is optional



**Figure 66:**  
 The information element is mandatory



Type 4 Information elements with variable length



**Figure 67:**  
 The information element is optional



**Figure 68:**  
 The information element is mandatory

The information elements which are common for at least two of the three sub-layers are listed in subclause 10.11.8.5.1. The information elements for the sub-layers radio resources management, CC and MR are listed in subclauses 10.11.8.5.2, 10.11.8.5.3 and 10.11.8.5.4 respectively. The coding of the information element identifier bits is summarized in tables 75, 91 and 103.

Different information elements may have the same information element identifier if they belong to different sub-layers.

The descriptions of the information elements are organized in alphabetical order. However, there shall be a particular order of appearance for each information element in a message.

The order of appearance for each information element which is mandatory in a message is laid down in the definition of the message (see subclause 10.11.9).

The order of the mandatory information elements shall be chosen so that information elements with 1/2 octet of content (type 1) go together in succession. The first type 1 information element shall occupy bits 1 to 4 of octet N, the second bits 5 to 8 of octet N, the third bits 1 to 4 of octet N+1 etc. If the number of type 1 information elements is odd then bits 5 to 8 of the last octet occupied by these information elements shall be treated as spare bits i.e. coded with a "0" in each.

The order of appearance in a message for each optional information element with fixed length (type 3) or with variable length (type 4) shall be determined by the information element identifier. The code values of the information element identifier for these formats shall be assigned in ascending numerical order, according to the actual order of appearance of each information element in the message. This shall allow the receiving equipment to detect the presence or absence of a particular optional information element of one of these two formats (types 3 and 4) without scanning through an entire message. Unrecognized information element identifiers shall be assumed to belong to an information element of type 4. For the detailed handling of unrecognized information element see clause 10.11.6.8.1. Optional information elements with 1/2 octet or 0 octet of content (types 1 and 2) may appear at any point among the optional information elements in a message.

Where the description of information elements in this ETS contains spare bits, these bits are indicated as being set to "0". In order to allow compatibility with future implementations, messages should not be rejected simply because a spare bit is set to "1".

An optional variable length information element may be present, but empty. This shall be interpreted by the receiver as equivalent to that information element being absent. Similarly, an absent information element shall be interpreted by the receiver as equivalent to that information element being empty.

The following rules apply for the coding of variable length information elements:

- a) the first digit in the octet number identifies one octet or a group of octets;

- b) each octet group shall be a self contained entity. The internal structure of an octet group may be defined in alternative ways;
- c) an octet group shall be formed by using an extension mechanism. The preferred extension mechanism shall be to extend an octet (N) through the next octet(s) (Na, Nb, etc.) by using bit 8 in each octet as an extension bit. The bit value "0" shall indicate that the octet continues through the next octet. The bit value "1" shall indicate that this octet is the last octet. If one octet (Nb) is present, also the preceding octets (N and Na) shall be present;

In the format descriptions appearing in subclauses 10.11.8.5.1 to 10.11.8.5.4, bit 8 is marked "0/1 ext" if another octet follows. Bit 8 shall be marked "1 ext" if this is the last octet in the extension domain.

Additional octets may be defined later ("1 ext" changed to "0/1 ext") and equipments shall be prepared to receive such additional octets although the equipment need not be able to interpret or act upon the content of these octets.

- d) in addition to the extension mechanism defined above, an octet (N) may be extended through the next octet(s) (N.1, N.2 etc.) by indications in bits 7-1 (of octet N);
- e) the mechanisms in c) and d) may be combined;
- f) optional octets are marked with asterisks (\*).

#### **10.11.8.5.1 Common information elements**

There shall be no common information elements.

#### **10.11.8.5.2 Radio resource management information elements**

For the RRM information elements listed below, the coding of the information element identifier bits is summarized in table 78.

**Table 78: Information element identifier for RRM information elements**

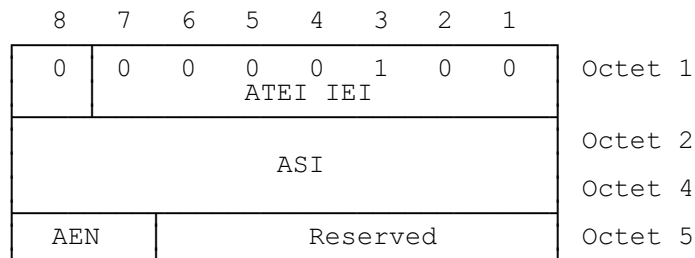
87654321 0:.....	Type 3&4 info elements	Reference subclause	Length in octets 1)
0000100	ATEI	10.11.8.5.2.1	F5
0001000	RR-Cause	10.11.8.5.2.2	F2
0010000	Cell management params	10.11.8.5.2.3	F10
0010001	Engineering Page	10.11.8.5.2.4	F5
0010010	ER-Primary freq.	10.11.8.5.2.5	F10
0010011	Page	10.11.8.5.2.6	F5
0010100	Primary frequency	10.11.8.5.2.7	F10
0000101	Radio channel number	10.11.8.5.2.8	F2
0000110	Resource request	10.11.8.5.2.9	F2
0000111	Relative e.i.r.p.	10.11.8.5.2.10	F2
0010101	Shutdown duration	10.11.8.5.2.11	F6
0001001	Slot allocation	10.11.8.5.2.12	F3
0010110	Time/Lat, Long	10.11.8.5.2.13	F7
0001010	Traffic channel ID	10.11.8.5.2.14	F2
0001011	GSIC	10.11.8.5.2.15	F4

NOTE: For fixed length information elements the length is indicated as F length value e.g. F3. For variable length information elements the length is indicated as Max length value (Max 10). The indicated length is the length including information element identifier and possible length indicator.  
When an information element is mandatory in a message the length is reduced by 1 octet as the information element identifier is stripped off.

**10.11.8.5.2.1 Aircraft Terminations Equipment Identity**

The ATEI information field shall be used to identify the aircraft and the aircraft equipment.

The ATEI shall be coded as shown in figure 69 and table 79.



**Figure 69: ATEI information field**

**Table 79: ATEI information field**

The ATEI is coded as follows:

(octet 2 - octet 4)

AS identity (ASI) according to the International Civil Aviation Organization (ICAO) Secondary Surveillance Radar (SSR) mode S aircraft 24 bits address as defined in the ICAO International Standards, recommended practices and procedures for air navigation services [36].

Bit 8 of octet 2 should be the first according to the ICAO mode and bit 1 of octet 4 the last one.

(octet 5)  
 Bits

8	7	Aircraft equipment number (AEN)	
0	0	Termination	1
0	1	-	2
1	0	-	3
1	1	-	4

6	5	4	3	2	1	
0	0	0	0	0	0	Reserved

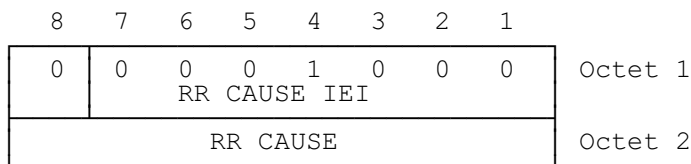
NOTE: Reference to Aeronautical Telecommunications Annex 10 to the convention on International Civil Aviation, Volume 1, Part 1 (Equipment and Systems, and Part 2, Radio Frequencies, Fourth edition of Volume 1 April 1985 [37].

**10.11.8.5.2.2 RR cause**

The purpose of the RR cause information field shall:

- indicate to the AS the cause for the rejection of a resource request or other failures on the GS side;  
 or
- indicate to the GS the reason for a failure of a handover process or other status indications on the AS side.

The cause information element shall be coded as shown in figure 70 and table 80.



**Figure 70: RR cause information field**

**Table 80: RR cause information field**

The RR cause information field is coded as follows:

(octet 2)  
 Bits

8	7	6	5	4	3	2	1	
0	0	0	0	0	0	0	0	No cause information
0	0	0	0	0	0	0	1	No resource available
0	0	0	0	0	0	1	0	GS does not support the requested service
0	0	0	0	0	0	1	1	Abnormal result, unspecified
0	0	0	0	0	1	0	0	Abnormal result, timer expired
0	0	0	0	0	1	0	1	AS is not allowed to enter the TFTS
0	0	0	0	0	1	1	0	Failure during the establishment of a physical or data link connection to the new GS. Successful reconnected to the old GS.
0	0	0	0	0	1	1	1	Failure during the establishment of a physical or data link connection
0	0	0	0	1	0	0	0	Successful handover to the new GS.
0	0	0	1	0	0	0	0	Abort of the connection between AS and GS because of a failure in the GSS.
1	1	1	0	0	0	0	1	Message non existent or not implemented
1	1	1	0	0	0	1	0	Message type not compatible with control state or message non existent or not implemented

other values are reserved.

**10.11.8.5.2.3 Cell management parameters**

The purpose of the cell management parameters information element shall be to give all relevant information to an AS for cell selection and cell control.

The cell management parameter information element shall coded as shown in figure 71 and table 81.

8	7	6	5	4	3	2	1	
0	0	0	1	0	0	0	0	Octet 1 Cell management IEI
0	LIM							Octet 2
LIM_K				LIM_ALT				Octet 3
0	QU_INT		MAX_ALT					Octet 4
RMIN				P_GS				Octet 5
Reserved								Octet 6 - 10

**Figure 71: Cell management parameters information element**

Table 81: Cell management parameter information element

The parameter LIM which gives the range limit of the current GS coded by 7 bits and with a resolution of 4 km.

(octet 2)	LIM
Bit 7	MSB
Bit 1	LSB

The parameter LIMK is coded by 4 bits with a resolution of 4 km.

(octet 3)	LIMK
Bit 8	MSB
Bit 5	LSB

The parameter LIM\_ALT is coded by 4 bits in integer numbers.

(octet 3)	LIM_ALT
Bit 4	MSB
Bit 1	LSB

The parameter QU\_INT is coded by 2 bits from 0 to 3 (integer number)

(octet 4)	QU_INT
Bit 7	MSB
Bit 6	LSB

The parameter MAX\_ALT is coded by 5 bits with a varying resolution. Altitude is given in feet.

"x" shows that the condition is inapplicable.

(continued)

Table 81 (concluded): Cell management parameter information element

(octet 4)	MAX_ALT		
Bit 5 4 3 2 1	AP GS	INT GS	ER GS
0 0 0 0 0	0	0	0
0 0 0 0 1	100	500	1000
0 0 0 1 0	200	1000	2000
0 0 0 1 1	300	1500	3000
0 0 1 0 0	400	2000	4000
0 0 1 0 1	500	2500	5000
0 0 1 1 0	600	3000	6000
0 0 1 1 1	700	3500	7000
0 1 0 0 0	800	4000	8000
0 1 0 0 1	900	4500	9000
0 1 0 1 0	1000	5000	10000
0 1 0 1 1	x	5500	11000
0 1 1 0 0	x	6000	12000
0 1 1 0 1	x	6500	13000
0 1 1 1 0	x	7000	14000
0 1 1 1 1	x	7500	15000
1 0 0 0 0	x	8000	16000
1 0 0 0 1	x	8500	18000
1 0 0 1 0	x	9000	20000
1 0 0 1 1	x	9500	22000
1 0 1 0 0	x	10000	24000
1 0 1 0 1	x	10500	26000
1 0 1 1 0	x	11000	28000
1 0 1 1 1	x	11500	30000
1 1 0 0 0	x	12000	32000
1 1 0 0 1	x	12500	34000
1 1 0 1 0	x	13000	36000
1 1 0 1 1	x	13500	38000
1 1 1 0 0	x	14000	40000
1 1 1 0 1	x	14500	43000
1 1 1 1 0	x	15000	> 43000
1 1 1 1 1	x	15500	> 43000

The parameter RMIN is coded by 4 Bits with a resolution of 1 dB.

(octet 5)	RMIN
Bit 8	MSB
Bit 5	LSB

The parameter PGS is coded by 4 bits with a resolution of 2 dB.

(octet 5)	P_GR
Bit 4	MSB
Bit 1	LSB

10.11.8.5.2.4 Engineering page

The engineering page information element shall be used to identify a specific engineering procedure.

The engineering page information element shall be coded as shown in figure 72 and table 82.

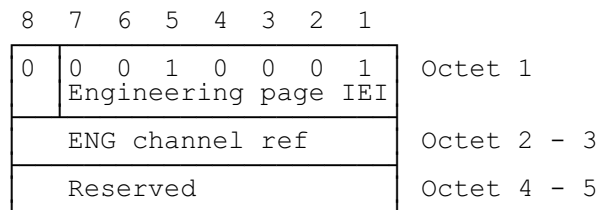


Figure 72: Engineering page information element

Table 82: Engineering page information element

The ENG (engineering page) channel reference is coded as follows:	
(octet 2 - octet 3)	ENG channel ref
Range 0 to 32767	
octet 2 Bit 8	high
octet 3 Bit 1	low

10.11.8.5.2.5 En-route (ER) - primary frequencies

The ER - primary frequency information element shall list the primary channels for ER GSs which shall be scanned by the AS for BCCH (D) data.

The ER - primary frequency information element shall be coded as shown in figure 73 and table 83.

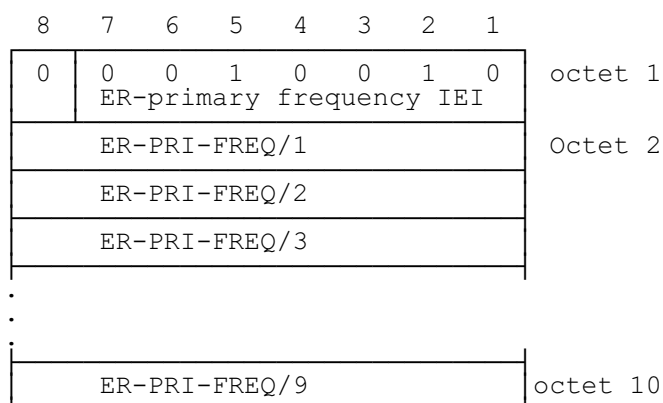


Figure 73: ER-primary frequency information element



**Table 83: ER-primary frequency information element**

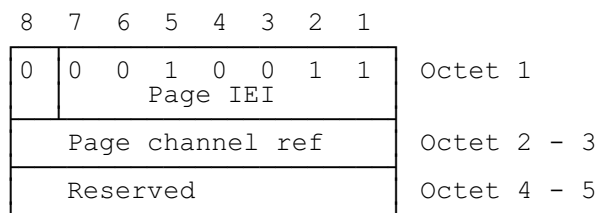
<p>The information field is coded as follows:</p> <p>9 channels x 8 bits/channel</p> <p>9 channels: which identifies the surrounding en-route GSs by their en-route primary frequency channel number</p> <p>8 bits/channel: gives the number of the channel to be used as primary frequency, coded as described in subclause 10.11.8.5.2.8.</p>
---

NOTE: The octets from the last frequency to the end of the information element are filled with the hex value "FF".

**10.11.8.5.2.6 Page**

The page information element shall be used to identify a specific paging procedure.

The page information element shall be coded as shown in figure 74 and table 84.



**Figure 74: Page information element**

**Table 84: Page information element**

The page channel reference is coded as follows:	
(octet 2 - octet 3)	Page channel Ref.
Range 0 to 32767	
octet 6 Bit 8	MSB
octet 7 Bit 1	LSB

**10.11.8.5.2.7 Primary frequencies**

The first three octets shall identify, additionally to subclause 10.11.8.5.2.5, ER primary frequencies. The remaining octets shall be used to identify the primary frequencies.

The primary frequencies information element shall be coded as shown in figure 75 and table 85.

NOTE: The fields from the last frequency to the end of the information element are filled with hex "FF".

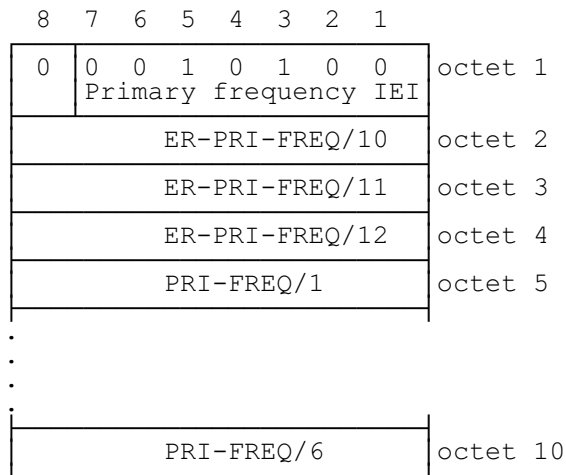


Figure 75: Primary frequency information element

Table 85: Primary frequency information element

<p>The information fields are coded as follows:</p> <p>(octet 2 - octet 4)                  3 channels x 8 bit/channel                  3 channels which identifies the surrounding en-route GSs by their primary en-route frequency channel number</p> <p>(octet 5 - octet 10)                  6 channels x 8 bits/channel                  6 channels which identify the surrounding non en-route GSs by the primary frequency channel number.</p> <p>8 bits/channel: gives the number of the channel to be used as primary frequency, coded as described in subclause 10.11.8.5.2.8.</p>
--

**10.11.8.5.2.8 Radio channel number**

The radio channel number information element shall provide a description of a specific allocated channel.

The radio channel information element shall be coded as shown in figure 76 and table 86.

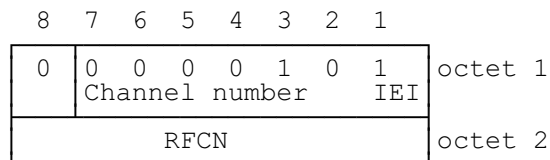


Figure 76: Radio frequency channel number (RFCN) information element

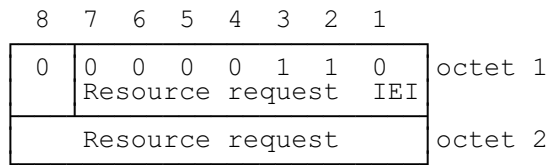
**Table 86: Allocated Radio Frequency Channel Number (RFCN) information element**

The RFCN is coded as the binary representation of the absolute RF channel number	
The definition of the RFCN is given in subclause 8.8	
Range 1 to 164	
Bit 1	low
Bit 8	high
The value for RFCN with all bits set to one is reserved to fill up the ER-Primary frequency and the Primary frequency information element.	
This value does not relate to a physical resource.	

**10.11.8.5.2.9 Resource request**

The resource request information element shall give information on the extend (number of time slots) and type (data coding) of the requested resource (F.S.).

The resource request information element shall be coded as shown in figure 77 and table 87.



**Figure 77: Resource request information element**

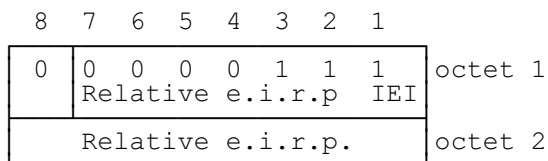
**Table 87: Resource request information element**

The Resource request field is encoded as follows:									
(octet 2)									
Bits									
8	7	6	5	4	3	2	1		
0	0	0	0	0	0	0	1	signalling 9,6 kbit/s	
0	0	0	0	0	0	1	0	signalling 4,8 kbit/s	
0	0	0	0	0	0	1	1	signalling 2,4 kbit/s	
0	0	0	0	0	1	0	1	speech full rate	
0	0	0	0	0	1	1	0	speech half rate	
0	0	0	0	0	1	1	1	speech quarter rate	
0	0	0	0	1	0	0	1	data 9,6 kbit/s	
0	0	0	0	1	0	1	0	data 4,8 kbit/s	
0	0	0	0	1	0	1	1	data 2,4 kbit/s	

**10.11.8.5.2.10 Relative e.i.r.p.**

The parameter shall give the initial relative e.i.r.p. in the AS to the GS in order to allow the GS to perform further power control adjustments.

The relative e.i.r.p. shall be coded as shown in figure 78 and table 88.



**Figure 78: Relative e.i.r.p. information field**

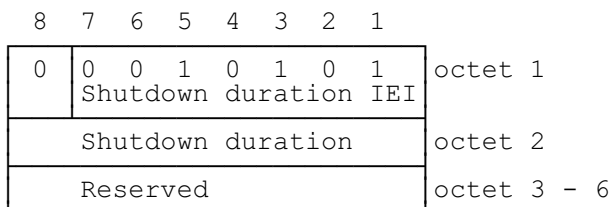
**Table 88: Relative e.i.r.p. information field**

The relative e.i.r.p. is coded in steps of - 5 dB and a range from 0 dB to - 75 dB:									
(octet 2)									
Bits									
8	7	6	5	Relative e.i.r.p.					
0	0	0	0	- 0 dB					
0	0	0	1	- 5 dB					
			.						
			.						
			.						
1	1	1	1	- 75 dB					

**10.11.8.5.2.11 Shutdown duration**

The shutdown duration information element shall identify the duration when the AS shall not communicate to the ground.

The shutdown information element shall be coded as shown in figure 79 and table 89.



**Figure 79: shutdown information element**

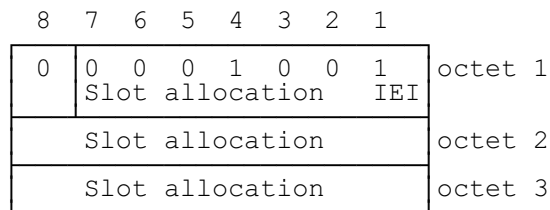
**Table 89: shutdown information element**

The shutdown duration is coded in integer from 1 to 255 in steps of five minutes. Value 0 is reserved for an infinite shutdown duration.	
(octet 2)	shutdown duration
Bit 8	high
Bit 1	low

**10.11.8.5.2.12 Slot allocation**

The slot allocation information element shall indicate to the AS the slots which are allocated to the requested resources.

The slot allocation element shall be coded as shown in figure 80 and table 90.



**Figure 80: slot allocation information element**

**Table 90: slot allocation information element**

The Slot allocation field is coded as follows:	
octet 2	
Bit	
8	identifies slot number 15
7	identifies slot number 14
.	
.	
1	identifies slot number 8
octet 3	
Bit	
8	identifies slot number 7
7	identifies slot number 6
.	
.	
1	identifies slot number 0
Bits corresponding to slots allocated to the AS are set to 1. All other bits are set to 0.	

10.11.8.5.2.13 Time/Lat, Long

This information element shall provide the actual time to the AS to ensure commonality of time stamps and the geographical position of the GS by latitude and longitude values (Lat, Long).

The time/lat, long information element shall be coded as shown in figure 81 and table 91.

8	7	6	5	4	3	2	1	
0	0	0	1	0	1	1	0	octet 1
Time/Lat, Long IEI								
year				month				octet 2
day								octet 3
hour				minutes				octet 4
latitude								octet 5
				longitude				octet 6
longitude (continued)								octet 7

**Figure 81: Time/Lat, Long information element**

Table 91: Time/Lat, Long information element

The Time parameter is coded as follows:

(octet 2)

Bits	
8 7 6 5 4	year, starting from the Base 1992
0 0 0 0 0	1992
0 0 0 0 1	1993
.	.
.	.
1 1 1 1 1	2023

(octet 2 - octet 3)

Bits	
3 2 1 8	month
0 0 0 1	January
0 0 1 0	February
.	.
.	.
1 1 0 0	December

other values are reserved.

(octet 3)

Bits	
7 6 5 4 3	day
0 0 0 0 1	1
0 0 0 1 0	2
.	.
.	.
1 1 1 1 1	31

other values are reserved.

(octet 3 - octet 4)

Bits	
2 1 8 7 6	hour
0 0 0 0 1	1
0 0 0 1 0	2
.	.
.	.
1 1 0 0 0	24

other values are reserved.

(octet 4 - octet 5)

Bits	
5 4 3 2 1 8	minutes
0 0 0 0 0 0	0
0 0 0 0 0 1	1
.	.
.	.2
1 1 1 0 1 1	59

(continued)

Table 91 (concluded): Time/Lat, Long information element

The Latitude (Lat) and the Longitude (Long) information is coded as two complement numbers in units of  $\pi \times 2^{-11}$  (in radians).

Latitude

Octet 5 and part 6

Bits	Radians
7 6 5 4 3 2 1 8 7 6 5	
0 0 0 0 0 0 0 0 0 0 0	0
0 0 0 0 0 0 0 0 0 0 1	$\pi \times 2^{-11}$
0 0 0 0 0 0 0 0 0 1 0	$2 \times \pi \times 2^{-11}$
.	
.	
0 1 1 1 1 1 1 1 1 1 1	$(2^{10} - 1) \times \pi \times 2^{-11}$
1 0 0 0 0 0 0 0 0 0 0	$-2^{10} \times \pi \times 2^{-11}$
1 0 0 0 0 0 0 0 0 0 1	$-(2^{10} - 1) \times \pi \times 2^{-11}$
1 0 0 0 0 0 0 0 0 1 0	$-(2^{10} - 2) \times \pi \times 2^{-11}$
.	
.	
1 1 1 1 1 1 1 1 1 1 0	$-2 \times \pi \times 2^{-11}$
1 1 1 1 1 1 1 1 1 1 1	$-\pi \times 2^{-11}$

The unit for latitude is  $\pi \times 2^{-11}$  radians and each bit change represents a change of  $\pi \times 2^{-11}$  radians. Since latitude is coded with 11 bits its value varies from  $-\pi/2$  to  $+\pi/2$ .

Longitude

Part octet 6 and octet 7

Bits	Radians
4 3 2 1 8 7 6 5 4 3 2 1	
0 0 0 0 0 0 0 0 0 0 0 0	0
0 0 0 0 0 0 0 0 0 0 0 1	$\pi \times 2^{-11}$
0 0 0 0 0 0 0 0 0 0 1 0	$2 \times \pi \times 2^{-11}$
.	
.	
0 1 1 1 1 1 1 1 1 1 1 1	$(2^{11} - 1) \times \pi \times 2^{-11}$
1 0 0 0 0 0 0 0 0 0 0 0	$-2^{11} \times \pi \times 2^{-11}$
1 0 0 0 0 0 0 0 0 0 0 1	$-(2^{11} - 1) \times \pi \times 2^{-11}$
1 0 0 0 0 0 0 0 0 0 1 0	$-(2^{11} - 2) \times \pi \times 2^{-11}$
.	
.	
1 1 1 1 1 1 1 1 1 1 1 1	$-\pi \times 2^{-11}$

The unit for longitude is  $\pi \times 2^{-11}$  radians and each bit change represents a change in longitude of  $\pi \times 2^{-11}$  radians. Longitude varies from  $-\pi$  to  $+\pi$  and is coded with 12 bits.





10.11.8.5.2.15 GS identity code

The purpose of the GSIC is to identify a GS in the TFTS Ground Network.

The GSIC information element shall be coded as shown in figure 83 and table 93.

8	7	6	5	4	3	2	1	
0	0	0	0	1	0	1	1	octet 1
GSIC IEI								
NOI / GCC								octet 2
NOI / GCC continued								octet 3
GSN						GCT		octet 4

Figure 83: GSIC information element

Table 93: GSIC information element

The network operator identity (NOI) identifies the operator uniquely. The GCC (Ground Switching Centre Code) identifies the GSC uniquely in the TFTS ground networks. The coding of this field is outside the scope of this ETS.

Coding using full hexadecimal representation may be used.

The GSN (GS Serial Number) identifies a GS belonging to a GSC.

In the GSN value bit 8 of octet 4 is the most significant bit and bit 3 of octet 4 is the least significant bit.

The coding of the GSC is in the responsibility of the operators.

The GCT (GS Cell Type) identifies the GS of the cell as en-route, intermediate or airport.

The coding is as follows:

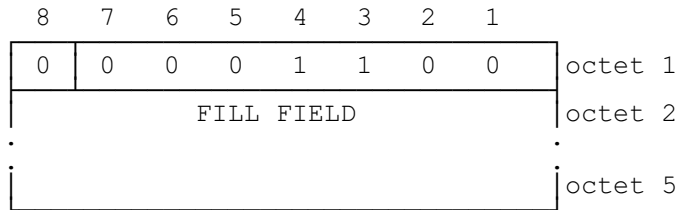
(octet 4)

Bits

2	1	
0	0	En-route GS
0	1	Intermediate GS
1	0	Airport GS
1	1	reserved

**10.11.8.5.2.16 Fill field**

The fill field shall be used to pad empty space in messages. The fill field shall be coded as shown in figure 84 and table 94.



**Figure 84: Fill field**

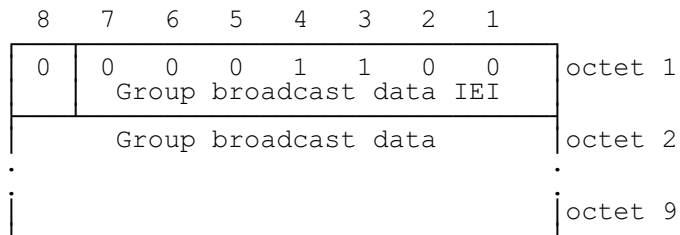
**Table 94: Coding of fill field**

The fill field is coded with FF Hex

**10.11.8.5.2.17 Group broadcast data**

The group broadcast data field carries information for general purposes (non system related) from the GSS to the AS.

The group broadcast data is coded as shown in figure 85.

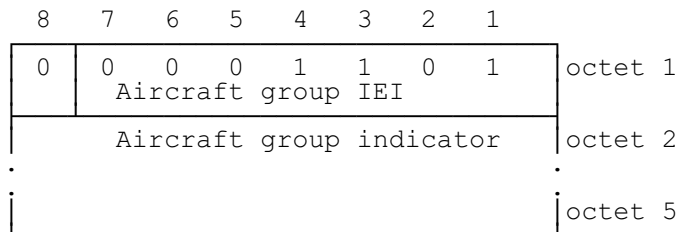


**Figure 85: Group broadcast data information element**

**10.11.8.5.2.18 Aircraft group**

The aircraft group information element is used to indicate the target audience of the group broadcast data such that the aircraft equipment can decide whether to attempt to decode the information in the group broadcast message.

The aircraft group information element is coded as shown in figure 86 and table 95.



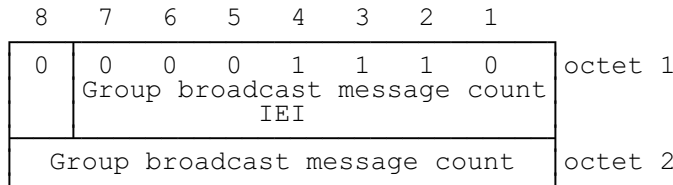
**Figure 86: Aircraft group information element**

**Table 95: Aircraft group information element**

The aircraft group is coded as IA5 characters (with bit 8 set to binary 0) except where the target audience (aircraft group) is not specified in which case each of the four octets shall be coded with all bits set to binary 1.

**10.11.8.5.2.19 Group broadcast message count**

The group broadcast message count information element indicates the number of group broadcast data transfer messages required to transmit the full group broadcast message. The group broadcast message count information element is coded as shown in figure 87 and table 96.



**Figure 87: Group broadcast data message count information element**

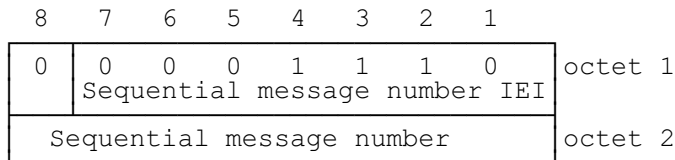
**Table 96: Group broadcast data message count information element**

The group broadcast message count is coded in binary integers in the range 1 to 255.

**10.11.8.5.2.20 Sequential message number**

The sequential message number element indicates the position of the current group broadcast data transfer message in the sequence whose length is defined by the group broadcast message data message count information element.

The sequential message number information element is coded as shown in figure 88 and table 97.



**Figure 88: Sequential message number information element**

**Table 97: Sequential message number information element**

The sequential message number is coded in binary integers in the range 1 to 255.

10.11.8.5.3 Call control information elements

For the CC information elements listed below, the coding of the information element identifier bits is summarized in table 98.

Table 98: Information element identifier coding for CC information elements

		Reference subclause	Length in octets 1)
8 7 6 5 4 3 2 1			
1 : : : - - - -	Type 1 info elements		
0 0 0	reserved		
1 0 1 - - - -	repeat indicator	10.11.8.5.3.14	F1
1 1 0 - - - -	connection type	10.11.8.5.3.14	F1
0 : : : : : : :	Type 3 & 4 info elements		
0 0 0 0 1 0 0	Bearer capability	10.11.8.5.3.2	Max 3 4)
0 0 0 1 0 0 0	Cause	10.11.8.5.3.6	Max 32
0 0 1 0 0 0 0	Aircraft information	10.11.8.5.3.1	F10
0 0 1 0 1 0 0	Call state	10.11.8.5.3.3	F2
0 0 1 1 1 1 0	Progress indicator	10.11.8.5.3.12	Max 4
0 1 0 0 1 1 1	Notification indicator	10.11.8.5.3.11	F2
0 1 0 1 1 0 0	Keypad facility 2)	10.11.8.5.3.9	F2
1 0 1 1 1 1 0	Called party BCD number	10.11.8.5.3.4	Max 13
1 1 0 1 1 0 1	Called party subadr.	10.11.8.5.3.5	Max 23
1 1 1 1 0 0 0	Credit card inform.	10.11.8.5.3.7	Max 40
1 1 1 1 1 0 0	Low layer compatib.	10.11.8.5.3.10	Max 15
1 1 1 1 1 0 1	High layer compatib.	10.11.8.5.3.8	Max 5
All other values are reserved 3)			
NOTE 1: For fixed length information elements the length is indicated as F length value e.g. F3. For variable length information elements the length is indicated as Max length value e.g. Max 10. The indicated length is the length included information element identifier and a possible length indicator. When an information element is mandatory in a message the length is reduced with 1 octet as the information element identifier is stripped off.			
NOTE 2: For the time being the only purpose of this information element is to transfer one DTMF digit.			
NOTE 3: The reserved value with bits 5-8 coded "0000" are for future information elements for which comprehension by the receiver is required (see subclause 10.11.6.8.1.1 Unrecognized information element).			
NOTE 4: The length of the Bearer Capability information element will be changed when information for data services are included.			

**10.11.8.5.3.1 Aircraft information**

The aircraft information shall convey information regarding a specific aircraft and call. The aircraft information shall be coded as shown in figure 89 and table 99.

8	7	6	5	4	3	2	1	
0	0	0	1	0	0	0	0	Aircraft information IEI
								octet 1
Flight operator identity								octet 2 - 4
digit 2				digit 1				octet 5
digit 4				digit 3				octet 6
Y				Y				octet 7
M				M				octet 8
D				D				octet 9
Service class identifier								octet 10

**Figure 89: Aircraft information element**

**Table 99: Aircraft information element**

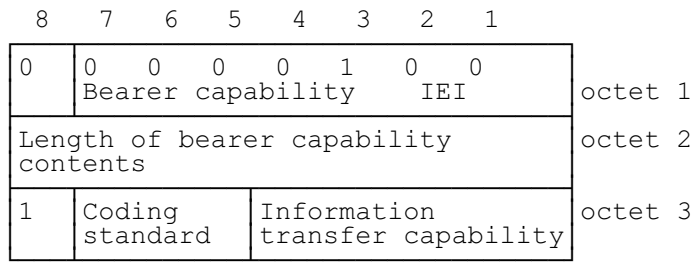
<p>Flight operator identity (octet 2-4)</p> <p>International Air Transport Association (IATA) Airline Designator, defined in the ATA/IATA Interline Communications Manual (Doc. GEN/1840, Revision 8) [38]. Consists of 2-3 alphanumeric characters in ASCII.</p> <p>Flight number (octet 5-6)</p> <p>The Flight number consists of 4 digits and is defined in the IATA Reservations Interline Message Procedures - Passenger Manual [39]. Digit 1 represents the most significant digit.</p> <p>Departure date (octet 7-9)</p> <p>The Departure date consists of 6 digits in the ISO date format (YYMMDD) and bits 1-4 are representing the most significant digit in an octet. The departure date is a local date.</p> <p>Service Class Identifier (octet 10)</p> <p>The service class identifier indicates the call originating handset classification and its value is defined by each airline.</p>
---

**10.11.8.5.3.2 Bearer capability**

The Bearer Capability (BC) information element shall indicate a requested bearer service to be provided by the network. It shall contain only information which may be used by the network.

The BC information element shall be coded as shown in figure 9 and table 100.

No default BC may be assumed by the absence of this information element. The BC is a type 4 information element.



NOTE: When specifying data services, the BC information element will be extended and the format of CCITT Recommendation Q.931 [21] might be used.

**Figure 90: Bearer capability information element**

**Table 100: Bearer capability information element**

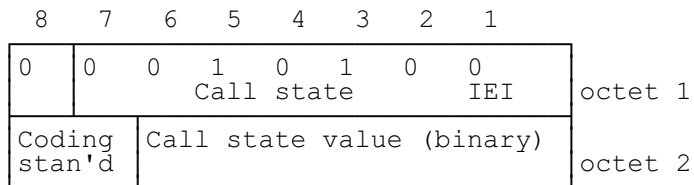
Coding standard (octet 3):	
Bits	
7 6	
0 0	TFTS standardised coding
All other values are reserved	
Information transfer capability (octet 3):	
Bits	
5 4 3 2 1	
0 0 0 0 0	Speech
All other values are reserved	

**10.11.8.5.3.3 Call state**

The call state information element shall describe the current status of a call (see subclause 10.11.4.1.2).

The call state information element shall be coded as shown in figure 91 and table 101.

The call state is a type 3 information element with 2 octets length.



**Figure 91: Call state information element**

Table 101: Call state information element

## Coding standard (octet 2)

Bits

8 7

0 0 standardized coding as described in CCITT Recommendation Q.931  
[21] (note)

0 1 reserved for other international standards (note)

1 1 standard defined for the TFTS as described below

NOTE: These other coding standards should be used only when  
the desired call state cannot be represented with the TFTS  
standardized coding.

## Call state value (octet 2)

Bits

0 0 0 0 0 0	U0	null	N0	null
0 0 0 0 1 0	U0.1	RR-connecting pending	N0.1	RR-connection available
0 0 0 1 1 0	U0.2	RR-release request	N0.2	Wait for RR-release
0 0 0 0 0 1	U1	call initiated	N1	call initiated
0 0 0 0 1 1	U3	aircraft originating call proceeding	N3	aircraft originating call proceeding
0 0 0 1 0 0	U4	call delivered	N4	call delivered
0 0 1 0 1 0	U10	active	N10	active
0 0 1 0 1 1	U11	disconnect request	N11	disconnect request
0 0 1 1 0 0	U12	disconnect indication	N12	discon. indication
0 1 0 0 1 1	U19	release request	N19	release request



**10.11.8.5.3.4 Called party BCD number**

The called party BCD number information element shall identify the called party.

The called party BCD number information element shall be coded as shown in figure 92 and table 102.

The called party BCD number is a type 4 information element with 13 octets length maximum.

8	7	6	5	4	3	2	1	
0	1	0	1	1	1	1	0	octet 1
Called party BCD number IEI								
Length of called party BCD number								octet 2
1	Type of number			Numbering plan identification				octet 3
digit 2				digit 1				octet 4
digit 4				digit 3				octet 5
see note 2								

NOTE 1: The number digit(s) in octet 4 precedes the digit(s) in octet 5 etc. The number digit which would be entered first is located in octet 4.

NOTE 2: If the called party BCD number contains an odd number of digits, bits 5 to 8 of the last octet shall be filled with an end mark coded as "1111".

**Figure 92: Called party BCD number information element**

Since the information element shall contain the complete called party BCD number there is no need for an additional complete-indication.

Table 102: Called party BCD number

Type of number (octet 3)

Bits

7	6	5	
0	0	0	reserved
0	0	1	international number (note 2)
0	1	1	TFTS network specific number (note 3)
1	0	0	reserved
1	0	1	reserved
1	1	0	reserved
1	1	1	reserved for extension

NOTE 1: For the definition of "number" see CCITT Recommendation I.330 [22].

NOTE 2: The type of number "international number" is used when the user has composed the international prefix (00). In this case the international prefix is not included.

NOTE 3: The type of number "TFTS network specific number" is used to indicate administration/service number specific to the serving network, e.g. used to access an operator.

Numbering plan identification (octet 3)

Number plan (applies for type of number = 000, 001, 010 and 100)

Bits

4	3	2	1	
0	0	0	0	reserved
0	0	0	1	ISDN/telephony numbering plan (CCITT Recommendation E.163 [26] and E.164 [23])
0	0	1	1	data numbering plan (CCITT Recommendation X.121 [27])
0	1	0	0	reserved
1	0	0	0	national numbering plan
1	0	0	1	private numbering plan
1	1	1	1	reserved

All other values are reserved.

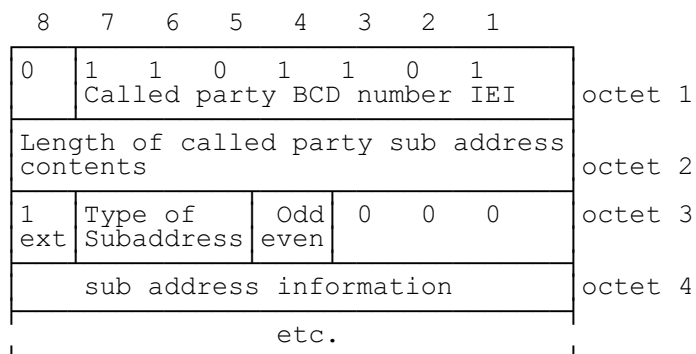
(continued)

**Table 102 (concluded): Called party BCD number**

Number digits (octets 4, etc.)	
Bits	Number digit value
4 3 2 1 or	
8 7 6 5	
0 0 0 0	0
0 0 0 1	1
0 0 1 0	2
0 0 1 1	3
0 1 0 0	4
0 1 0 1	5
0 1 1 0	6
0 1 1 1	7
1 0 0 0	8
1 0 0 1	9
In accordance with CCITT Recommendations E.164 [23] and I.330, [22] only the decimal digits 0-9 shall be used in number information.	
1 0 1 0	*
1 0 1 1	#
1 1 0 0	a
1 1 0 1	b
1 1 1 0	c
1 1 1 1	used as endmark in case of an odd number information

**10.11.8.5.3.5 Called party subaddress**

The called party subaddress shall identify the subaddress of the called party of a call. For the definition of a subaddress see CCITT Recommendation I.330 [22]. The called party subaddress information element shall be coded as shown in figure 93 and table 103 The maximum length of this information element shall be 23 octets



**Figure 93: Called party subaddress**

Table 103: Called party subaddress

Type of subaddress (octet 3)
Bits
7 6 5
0 0 0 AP (CCITT Recommendation X.213 [29]/ISO 8348 [30] AD2)
0 1 0 User specified
All other values are reserved
Odd/even indicator (octet 3)
Bit
4
0 even number of address signals
1 odd number of address signals
NOTE: The odd/even indicator is used when the type of subaddress is "user specified and the coding is BCD
Subaddress information (octet 4, etc...) The NSAP CCITT Recommendation X.213/ISO 8348 AD2 address shall be formatted as specified by octet 4 which contains the Authority and Format Identifier (AFI). The encoding is made according to the "preferred binary encoding" as defined in CCITT Recommendation X.213/ISO 8348 AD2. For the definition of this type of this type of subaddress, see CCITT Recommendation I.332 [24].
For User-specific subaddress, this field is encoded according to the user specification, subject to a maximum length of 20 octets. When interworking with CCITT Recommendation X.25 networks, BCD coding should be applied.
NOTE: It is recommended that users apply NSAP subaddress type since this subaddress type allows the use of decimal, binary and IA5 characters in a standardised manner.

**10.11.8.5.3.6 Cause**

The cause information element shall describe the reason for generating certain messages, shall provide diagnostic information in the event of procedural errors and shall indicate the location of the cause originator.

The cause information element shall be coded as shown in figure 94 and table 104.

The cause is a type 4 information element with 32 octets length maximal.

The cause information element may be repeated in a message.

	8	7	6	5	4	3	2	1	
	0	0	0	1	0	0	0	0	octet 1
	Cause IEI								
	Length of cause contents								octet 2
0/1 ext	Coding standard	0	Location						octet 3
1 ext	Recommendation								octet 3a
1 ext	Cause value								octet 4
	Diagnostic (if any)								octet 5

NOTE: If the default value applies for the recommendation field, octet 3a shall be omitted.

**Figure 94: Cause information element**

Table 104: Cause information element

Coding standard (octet 3)

Bits		
7	6	
0	0	Standard as described in CCITT Recommendation Q.931 [21] (note 1)
0	1	Reserved for other international standards (note 1)
1	1	Standard defined for the TFTS as described in table 98

NOTE 1: These other coding standards shall be used only when the desired cause cannot be represented with the TFTS standardized coding.

Location (octet 3)

Bits				
4	3	2	1	
0	0	0	0	user
0	0	0	1	private network serving the local user
0	0	1	0	public network serving the local user
0	0	1	1	transit network
0	1	0	0	public network serving the remote user
0	1	0	1	private network serving the remote user
0	1	1	1	international network
1	0	1	0	network beyond interworking point

All other values are reserved.

Recommendation (octet 3a)

Bits							
7	6	5	4	3	2	1	
0	0	0	0	0	0	0	CCITT Recommendation Q.931 [21]
0	0	0	0	0	0	1	TFTS Recommendation (see note 3)
0	0	0	0	0	1	1	CCITT Recommendation X.21 [31]
0	0	0	0	1	0	0	CCITT Recommendation X.25 [32]

All other values are reserved.

NOTE 2: If octet 3a is omitted.

NOTE 3: This value is used only when octet 3a is extended and the cause in octet 4 is from table 98.

(continued)

**Table 104 (concluded): Cause information element**

Cause value (octet 4)

The cause value is divided in two fields: a class (bits 5 through 7) and a value within the class (bits 1 through 4).

The class indicates the general nature of the event.

Class (000):normal event

Class (001):normal event

Class (010):resource unavailable

Class (011):service or option not available

Class (100):service or option not implemented

Class (101):invalid message (e.g. parameter out of range)

Class (110):protocol error (e.g. unknown message)

Class (111):interworking

The cause values are listed in table 105

Diagnostic(s) (octet 5)

Diagnostic information is not available for every cause, see table 98 below.

When available, the diagnostic(s) is coded in the same way as the corresponding information element in subclause 10.

The inclusion of diagnostic(s) is optional.

Table 105: Cause information element values

cause value	cause number	cause	diagnostic
765	4321		
000	0001	1 unassigned (unallocated) number	note 6
000	0011	3 no route to destination	note 6
000	0110	6 channel unacceptable	
001	0000	16 normal clearing	note 6
001	0001	17 user busy	
001	0010	18 no user responding	
001	0011	19 user alerting, no answer	
001	0100	20 credit card rejected	
001	0101	21 call rejected (user supplied diagnostic)	note 6 note 3
001	0110	22 number changed new destination	note 4
001	1010	26 non selected user clearing	
001	1011	27 destination out of order	
001	1100	28 invalid number format (incomplete number)	
001	1101	29 facility rejected	
001	1110	30 response to STATUS ENQUIRY	
001	1111	31 normal unspecified	
010	0010	34 no circuit/channel available	
010	0100	38 network out of order	
010	1001	41 temporary failure	
010	1010	42 switching equipment congestion	
010	1011	43 access information discarded	note 7
010	1100	44 requested circuit/channel not available	
010	1111	47 resources unavailable, unspecified	
011	0001	49 quality of service unavailable	note 6
011	1001	57 bearer capability not authorised	note 2
011	1010	58 bearer capability not presently available	note 2
011	1111	63 service or option not available, unspecified	
100	0001	65 bearer service not implemented	note 2
100	0101	69 requested facility not implemented	
100	0110	70 only restricted digital information bearer capability is available	
100	1111	79 service or option not available, unspecified	
101	0001	81 invalid transaction identifier value	
101	1000	88 incompatible destination, incompatible parameter	note 1
101	1011	91 invalid transit network selection	
101	1111	95 invalid message, unspecified	
110	0000	96 mandatory information element error	note 7
110	0001	97 message type non existent or not implemented message type	
110	0010	98 message not compatible with control state or message type non existent or not implemented message type	
110	0011	99 information element non existent	note 7

(continued)



**Table 105 (concluded): Cause information element values**

cause value	cause number	cause	diagnostic
110	0100	100	note 7
110	0101	101	
110	0110	102	note 5
110	1111	111	
111	1111	127	
All other values are reserved			
NOTE 1: Incompatible parameter is composed of incompatible information element identifier.			
NOTE 2: The format of the diagnostic field for causes number 57, 58 and 65 is as shown in figure 98 and table 93			
NOTE 3: User supplied diagnostics field is encoded according to the user specification, subject to the maximum length of the cause information element. The coding of user supplied diagnostics should be made in such a way that it does not conflict with the coding described in note 6 below.			
NOTE 4: New destination is formatted as the called party number information element, including information element identifier.			
NOTE 5: The timer number is coded in IA5 characters, e.g. T308 is coded as "3" "0" "8". The following coding is used in each octet:			
<div style="margin-left: 40px;"> bit 8 : spare "0"  bits 7-1: IA5 character </div>			
NOTE 6: The following coding is used:			
<div style="margin-left: 40px;"> bit 8 :1  bits 7-3 :00000  bits 2-1 :condition as follows:   00 - unknown  01 - transient  10 - transient </div>			
NOTE 7: The diagnostics field contains the information element identifiers.			

**10.11.8.5.3.7 Credit card information**

The credit card information shall convey information used for billing purposes and credit card authorisation. The credit card information shall be coded as shown in figure 95. The maximum length of this information element shall be 40 octets.

8	7	6	5	4	3	2	1	
0	1	1	1	1	0	0	0	Credit card information IEI
								octet 1
Length of credit card information								octet 2
Credit card information								octet 3
etc.								

**Figure 95: Credit card information**

The credit card information shall contain track 1 or track 2 Longitudinal Redundancy Check (LRC) and parity bits are excluded) as defined in ISO 7813 [25].

**10.11.8.5.3.8 High layer compatibility**

The high layer compatibility information element shall provide a means which shall be used by the remote user for compatibility checking.

The high layer compatibility information element shall be coded as shown in figure 96 and table 106.

The high layer compatibility is a type 4 information element with 5 octets length maximal.

NOTE: The high layer compatibility information element is transported transparently between a call originating entity, e.g. a calling user and the addressed entity, e.g. a remote user or a high layer function network node addressed by the call originating entity. However, if explicitly requested by the user (at subscription time), a network which provides some capabilities to realize teleservices may interpret this information to provide a particular service.

8	7	6	5	4	3	2	1	
0	1	1	1	1	1	0	1	High layer compatibility IEI
								Octet 1
Length of high layer compatibility contents								Octet 2
1	Coding std	Interpre- tation of protocol profile	Method of present'n					Octet 3
0/1 ext	High layer characteristics identification							Octet 4
1 ext	Extended high layer characteristics ident							Octet 4a note

**Figure 96: High layer compatibility information element**

NOTE: This octet may be present e.g. when octet 4 indicates Maintenance or Management.

**Table 106: high layer compatibility information element**

Coding standard (octet 3) see CCITT Recommendation Q.931 [21].
Interpretation (octet 3) see CCITT Recommendation Q.931 [21].
Presentation method of protocol profile (octet 3) see CCITT Recommendation Q.931 [21].
High layer characteristics identification (octet 4) see CCITT Recommendation Q.931 [21].
Extended high layer characteristics identification (octet 4a) (alternative 2) see CCITT Recommendation Q.931 [21].

**10.11.8.5.3.9 Keypad facility**

The keypad facility information element shall convey IA5 characters, e.g. entered by means of a terminal keypad (see note).

The keypad facility information element shall be coded as shown in figure 97.

The keypad facility is a type 3 information element with 2 octets length.

8	7	6	5	4	3	2	1	
0	0	1	0	1	1	0	0	Octet 1
Keypad facility IEI								
Keypad information (IA5 character)								Octet 2

NOTE: In the TFTS system this information element is only used to transfer one IA5 character as one DTMF digit (0, 1, ... , 9, A, B, C, D, \*, #).

**Figure 97: Keypad facility information element**

**10.11.8.5.3.10 Low layer compatibility**

The Low Layer Compatibility (LLC) information element shall provide a means which shall be used for compatibility checking by an addressed entity (e.g., a remote user or an interworking unit or a high layer function network node addressed by the calling user). The LLC information element shall be transferred transparently between the call originating entity (e.g. the calling user) and the addressed entity.

The LLC information element shall be coded as in CCITT Recommendation Q.931 [21].

The LLC is a type 4 information element with 15 octets length maximal.

To allow a LLC information element to contain only information which is required in addition to the BC information element (thereby avoiding duplication of information between LLC and BC information elements) a LLC interpretation octet may be included in the LLC information element following octet 2. The octet indicates the content of the subsequent octet. It shall be coded as in CCITT Recommendation Q.931 [21].

The coding for TFTS shall be the same as for the ISDN.

**10.11.8.5.3.11 Notification indicator**

The notification indicator information element shall indicate information pertaining to a call.

The notification indicator element shall be coded as shown in figure 98 and table 107.

The notification indicator is a type 3 information element with 2 octets length.

	8	7	6	5	4	3	2	1	
0	0	1	0	0	1	1	1	1	Octet 1
	Notification indicator IEI								
1 ext	Notification description								Octet 2

**Figure 98: Notification indicator information element**

**Table 107: Notification indicator information element**

Notification description (octet 2)	
Bits	
7 6 5 4 3 2 1	
0 0 0 0 0 0 0	User suspended
0 0 0 0 0 0 1	User resumed
0 0 0 0 0 1 0	Bearer change
All other values are reserved.	

**10.11.8.5.3.12 Progress indicator**

The progress indicator information element shall describe an event which has occurred during the life of a call. The information element may occur twice in a message.

The progress indicator information element shall be coded as shown in figure 99 and table 108.

The progress indicator is a type 4 information element with 4 octets length maximal.

	8	7	6	5	4	3	2	1	
0	0	0	1	1	1	1	1	0	Octet 1
	Progress indicator IEI								
	Length of progress indicator contents								Octet 2
1 ext	Coding std	0 Spare			Location				Octet 3
1 ext	Progress description								Octet 4

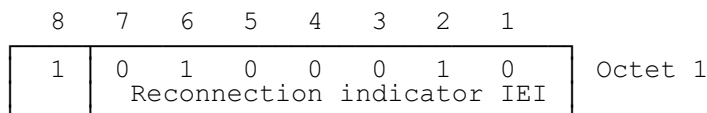
**Figure 99: Progress indicator information element**

**Table 108: Progress indicator information element**

Coding standard (octet 3)	
Bits	
7 6	
0 0	Standardized coding, as described in CCITT Recommendation Q.931 [21] (note)
0 1	Reserved for other international standards (see note 1)
1 1	Standard defined for the TFTS as described below
NOTE 1: These other coding standards should be used only when desired cause can not be represented with the TFTS-standardized coding.	
Location (octet 3)	
Bits	
4 3 2 1	
0 0 0 0	User
0 0 0 1	Private network serving the local user
0 0 1 0	Public network serving the local user
0 1 0 0	Public network serving the remote user
0 1 0 1	Private network serving the remote user
1 0 1 0	Network beyond interworking point
All other values are reserved.	
NOTE 2: Depending on the location of the users, the local public network and remote public network may be the same network.	
Progress description (octet 4)	
Bits	
7 6 5 4 3 2 1	No.
0 0 0 0 0 0 1	1. Call is not end-to-end TFTS/ISDN, further call progress information may be available in-band
0 0 0 0 0 1 0	2. Destination address in non-TFTS/ISDN
0 0 0 0 1 0 0	4. Call has returned to the TFTS/ISDN
0 0 0 1 0 0 0	8. In-band information or appropriate pattern now available
All other values are reserved.	

**10.11.8.5.3.13 Reconnection indicator**

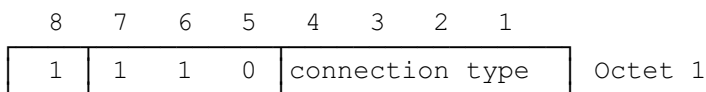
The reconnection indicator information element shall indicate that the call is a re-establishment of a previously disconnected call due to a failure situation. See figure 100.



**Figure 100: Reconnection indicator information element**

**10.11.8.5.3.14 Connection type**

The purpose of the connection type information element is to indicate that the call is a re-establishment of a previously disconnected call due to a failure situation. See figure 101 and table 109.



**Figure 101: Connection type**

**Table 109: Connection type**

Connection type (octet 1)	
Bits	
4 3 2 1	
0 0 0 0	first connection
0 0 0 1	reconnection
all other values reserved	

**10.11.8.5.4 MR information elements**

For the MR management information elements listed below, the coding of the information element identifier bits is summarized in table 110.

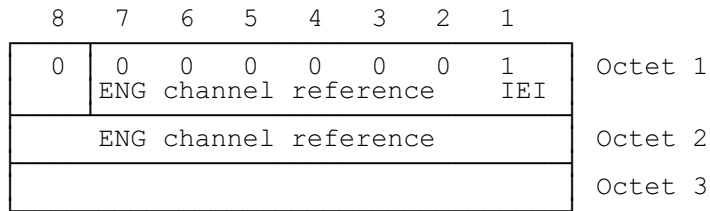
**Table 110: Information element identifier coding for MR management information elements**

		Reference subclause	Length in octets (note)
87654321			
0 :::::	Type 3&4 info elements		
0000001	ENG Channel Reference	10.11.8.5.4.1	F3
0000010	ATEI	10.11.8.5.4.2	F5
0000100	Data information	10.11.8.5.4.3	Max. 240
0001000	PAGE Channel Reference	10.11.8.5.4.4	F3
0010000	MR-Cause	10.11.8.5.4.5	F2
NOTE:	For fixed length information elements the length is indicated as F length value e.g. F3. For variable length information elements the length is indicated as Max length value e.g. Max 10. The indicated length is the length including information element identifier and a possible length indicator. When an information element is mandatory in a message the length is reduced by 1 octet as the information element identifier is stripped off.		

**10.11 8.5.4.1 ENG channel reference**

This ENG paging channel reference information element shall identify the process in Ground Network.

The ENG channel reference information element shall be coded as shown in figure 101 and table 111.



**Figure 101: ENG channel reference information element**

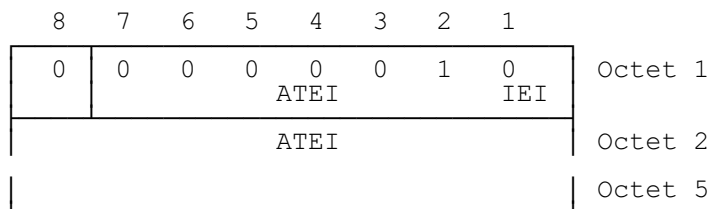
**Table 111: ENG channel reference information element**

ENG Channel Reference: (octet 2 -3)
Range 0 to 32767
octet 2 Bit 8:       MSB
octet 3 Bit 1:       LSB

**10.11.8.5.4.2 Aircraft Terminations Equipment Identifier**

This information element shall identify the aircraft and the aircraft equipment.

The ATEI shall be coded as shown in figure 102 and table 112.



**Figure 102: ATEI information field**

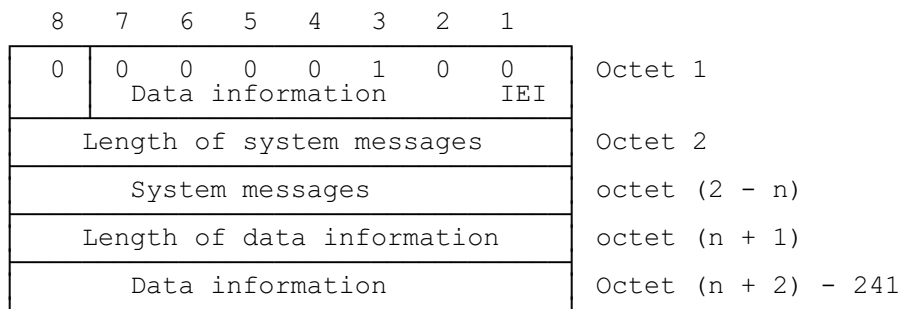
**Table 112: ATEI information field**

Addressee ATEI: (octet 2 - 3)
octet 2 - 5 = ATEI

**10.11.8.5.4.3 Data information**

The data information element shall be used to transfer data between the AS and the GS.

The data information information element shall be coded as shown in figure 103 and table 113 and table 113a.



**Figure 103: Data information information field**

**Table 113: System messages field**

System message: (octet 2 - n)
Service provider specific

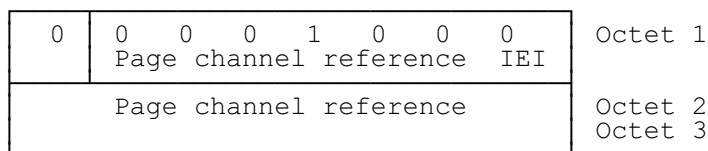
**Table 113a: Data information field**

Data information: octet (n + 1) - 241
Set of Octets

**10.11.8.5.4.4 PAGE channel reference**

The paging channel reference shall identify the process in ground network.

The PAGE channel reference information element shall be coded as shown in figure 104 and table 114.



**Figure 104: PAGE channel reference information element**

**Table 114: PAGE channel reference information element**

PAGE channel reference: (octet 2 - 3)
Range 0 to 32767
octet 2 Bit 8            high
octet 3 Bit 1            low



10.11.8.5.4.5 MR-cause

The cause information element shall be coded as shown in figure 105 and table 115.

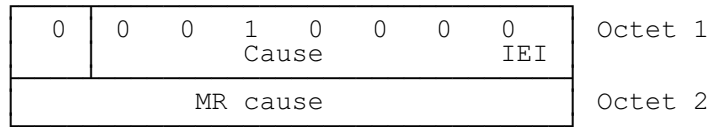


Figure 105: Cause information field

Table 115: MR cause information field

The MR Cause information field is coded as follows:

(octet 2)

8	7	6	5	4	3	2	1	
0	1	1	0	0	0	0	0	Mandatory information element error
0	1	1	0	0	0	0	1	Message type non-existent or not implemented
0	1	1	0	0	0	1	0	Message not compatible with control state or message type non-existent or not implemented
0	1	1	0	0	0	1	1	Information element non-existent or not implemented
0	1	1	0	0	1	0	0	Invalid information element contents
0	1	1	0	1	0	0	0	Invalid reference number

other values are reserved.

## 10.11.9 List of system parameters

## 10.11.9.1 Timers of circuit-switched CC

Table 116: Call control timers - AS side

TIM NO	TIM VAL	STATE OF CALL	CAUSE OF START	NORMAL STOP	AT FIRST EXPIRY	AT SECOND EXPIRY	CROSS REF.
T301	90 sec	Call delivered	ALERT received	CONNECT received	Clear call	Timer is not restarted	Mand. note 1
T303	30 sec	Call init. RR-conn. Pending	Resources requested	CALL PROC or REL COMP received	Clear call	Timer is not restarted	Mand.
T305	30 sec	Disconnect request	DISC sent	REL or DISC received	REL sent	Timer is not restarted	Mand.
T308	10 sec	Release request	REL sent	REL or REL COMP received	Retransmit RELEASE restart T308	Release used radio resources	Mand.
T310	20 sec	AS origin Call proc.	CALL PROC received	ALERT, CONN, DISC, PROG rec.	Send Disc	Timer is not restarted	Mand. note 2
T322	22 sec	Any state except NULL, RR-conn. Pending	STATUS ENQUIRY sent	STATUS DISC, REL or REL COMP received	Retransmit STAT ENQ	Clear the call	

NOTE 1: The AS may already have applied an internal alerting supervision function, e.g. incorporated unit CC. If such a function is known to be operating on the call, then timer T301 is not used.

NOTE 2: T310 is not started if progress indicator #1 or #2 has been delivered in the CALL PROCEEDING message or in a previous PROGRESS message.

Table 117: Call control timers - GSS side

TIM NO	TIM VAL	STATE OF CALL	CAUSE OF START	NORMAL STOP	AT FIRST EXPIRY	AT SECOND EXPIRY	CROSS REF.
T305	30 sec	Disconnect indication	DISC sent without prog. ind #8	REL or DISC received	send REL	Timer is not restarted	Mand.
T306	30 sec	Disconnect indication	DISC sent with prog. ind #8	REL or DISC received	stop the tone/ announc. Send REL	Timer is not restarted	Mand. note
T308	10 sec	Release request	REL sent	REL COMP or REL received	Retransmit RELEASE restart T308	Release used radio resources	Mand.
T322	20 sec	Any state except NULL, RR-conn. Pending	STATUS ENQUIRY sent	STATUS DISC, REL or REL COMP received	Retransmit STAT ENQ	Clear the call	
NOTE: Mandatory when in-band tones/announcements are provided							

### 10.11.9.2 Timers and counters for RRM

#### 10.11.9.2.1 Timers on the GS side

T3100: This timer controls the handover process in the new GS which had confirmed the requested handover.

Its value is set to default 25 sec.

T3101: This timer controls the establishment of the data link layer.

Its value is set to default 10 sec.

T3102: This timer controls the release of a resource initiated by the GS.

Its value is set to default 15 sec.

T3103: After the new GS has received the CHANNEL-ACCESS primitive during a handover the timer controls to re-establishment of the data link.

Its value is set to default 10 sec.

T3104: This timer controls the handover process in the old GS while waiting for a HANDOVER-COMPLETE message or a re-establishment.  
Its value is set to default 30 sec.

T3105: This timer controls the release of a resource initiated by the AS.  
Its value is set to default 15 sec.

#### 10.11.9.2.2 Timers on the AS side

T3010: Between two allowed access procedures the AS is to wait a random time to reduce the possibility of message collision with other aircraft.  
The value of T3010 is set to 10 sec.

T3050: This timer controls the handover process while waiting for the response from the ground.  
The value of this timer is default 20 sec.

#### 10.11.9.2.3 Counters on the AS side

CT3000: This counter gives the actual number of attempts on different channels. If the maximum number of attempts N3000 is reached the RR-ESTABLISH-REQUEST has failed.  
The maximum number N3000 is set to 2.

#### 10.11.9.2.4 Counters on the GS side

CT3100: This counter gives the actual number of re-transmissions of the page message. If the maximum number of N3100 of re-transmissions is reached the page message is deleted from the BCCH(D).  
The value of N3100 is in the responsibility of the operators.

CT3101: This counter gives the actual number of re-transmissions of the ENGPAGE message. If the maximum number of N3101 of re-transmissions is reached the ENGPAGE message is deleted from the BCCH(D).  
The value of N3101 is in the responsibility of the operators.

CT3102: This counter gives the actual number of re-transmissions of the shutdown message. If the maximum number of N3102 of re-transmissions is reached the shutdown message is deleted from the BCCH(D).  
The value of N3102 is in the responsibility of the operators.

#### 10.11.9.3 Timer values for MR management

##### 10.11.9.3.1 Timer values on AS side

T3010: This timer controls the setup time of a PAGING or ENGPAGE request from the MR.  
The value of T3010 is set to default 30 sec.

T3020: This timer controls the release of resources allocated to the MR management.

The value of T3020 is set to default 30 sec.

T3060: This timer controls the time for the shutdown duration. The shutdown duration is given in integer number from 1 to 255 units in steps of five minutes.

The value 0 is reserved for an infinite shutdown duration.

### 10.11.9.3.2 Timer values on GS side

T3110: This timer controls the release of resources allocated to the MR originated from GS side.

The value of T3110 is set to default 10 sec.

### 10.11.10 Definition of primitive parameters

Table 118: Call control timers - GSS side

Generic name and type	Appearance	Parameters
MN-Setup-request	AS	-Information needed for the SETUP message
MN-Setup-confirm	AS	-Information received in the CONNECT message or - ERROR
MN-Setup-indication	GSS	-Information received in the SETUP message
MN-Setup-response	GSS	-Information needed for the CONNECT message
MN-Reject-request	GSS	-Information needed for the RELEASE COMPLETE message
MN-Reject-indication	AS	-Information received in the RELEASE COMPLETE message or other reject cause
MN-Proceeding-request	GSS	-Information needed for the CALL PROCEEDING message
MN-Proceeding-indication	AS	Information needed in the CALL PROCEEDING message
MN-Progress-request	GSS	-Information needed for the PROGRESS message
MN-Send-DTMF-request	AS	-DTMF digit to be sent
MN-Send-DTMF-confirm	AS	-DTMF digit that has been sent or Error, if rejected by the GSS
MN-Send-DTMF-indication	GSS	-DTMF digit
MN-Send-DTMF-response	GSS	-DTMF tone applied towards the network or Error
MN-Alerting-request	GSS	-Information needed for the ALERTING message
MN-Alerting-indication	AS	-Information received in the ALERTING message

(continued)

Table 118 (continued): Call control timers - GSS side

Generic name and type	Appearance	Parameters
MN-Disconnect-request	AS GSS	-Information needed for the DISCONNECT message
MN-Disconnect-indication	AS GSS	-Information received in the DISCONNECT message or -Error
MN-Release-request	AS GSS	-Information needed for the RELEASE message
MN-Release-indication	AS GSS	-Information received in the RELEASE message or - other release cause
MN-Release-confirm	AS GSS	-Information received in the RELEASE or RELEASE COMPLETE message or - Error
MN-Notify-request	AS	-Information needed for the NOTIFY GSS message
MN-Notify-indication	AS	-Information received in the NOTIFY GSS
MN-Status-indication	AS	-Information received in the STATUS GSS message
MN-Progress-indication	AS	-Information received in the PROGRESS message
RR-Est-req	AS	-TI assigned to the involved CM entity - Requested resources
RR-Est-cnf	AS	-TI assigned to the involved CM entity In the case of unsuccessful establishment this will be indicated by the parameter error
RR-Est-ind	GSS	-TI assigned to the involved CM entity
RR-Rel-req	AS GSS	-TI assigned to the involved CM entity
RR-Rel-cnf	AS	-TI assigned to the involved CM entity
RR-Rel ind	AS	-TI assigned to the involved CM entity
RR-Data-req	AS GSS	-Layer 3 peer-to-peer message
RR-Data-ind	AS GSS	-Layer 3 peer-to-peer message
RR-Abort-ind	AS GSS	

(continued)

**Table 118 (concluded): Call control timers - GSS side**

RR-Connect-req	AS GSS	- TI assigned to the involved CM entity
RR-Disconnect-req	AS GSS	- TI assigned to the involved CM entity
RR-Shutdown-ind	AS	
RR-Page-ind	AS	- TI assigned to the involved CM entity
RR-Engpage-ind	AS	- TI assigned to the involved CM entity
RR-Available-ind	AS	
RR-Activate-Command-req	AS	
RR-Shutdown-Command-req	AS	
RR-Shutdown-req	GSS	
RR-Page-Channel-req	GSS	- TI assigned to the involved CM entity
RR-Engpage-Channel-req	GSS	- TI assigned to the involved CM entity

**10.11.11 SDL of TFTS layer 3 processes**

These diagrams are included to aid implementation of the TFTS Layer 3 protocols. The text in subclauses 10.11.2, 10.11.3, 10.11.4 and 10.11.5 takes precedence.

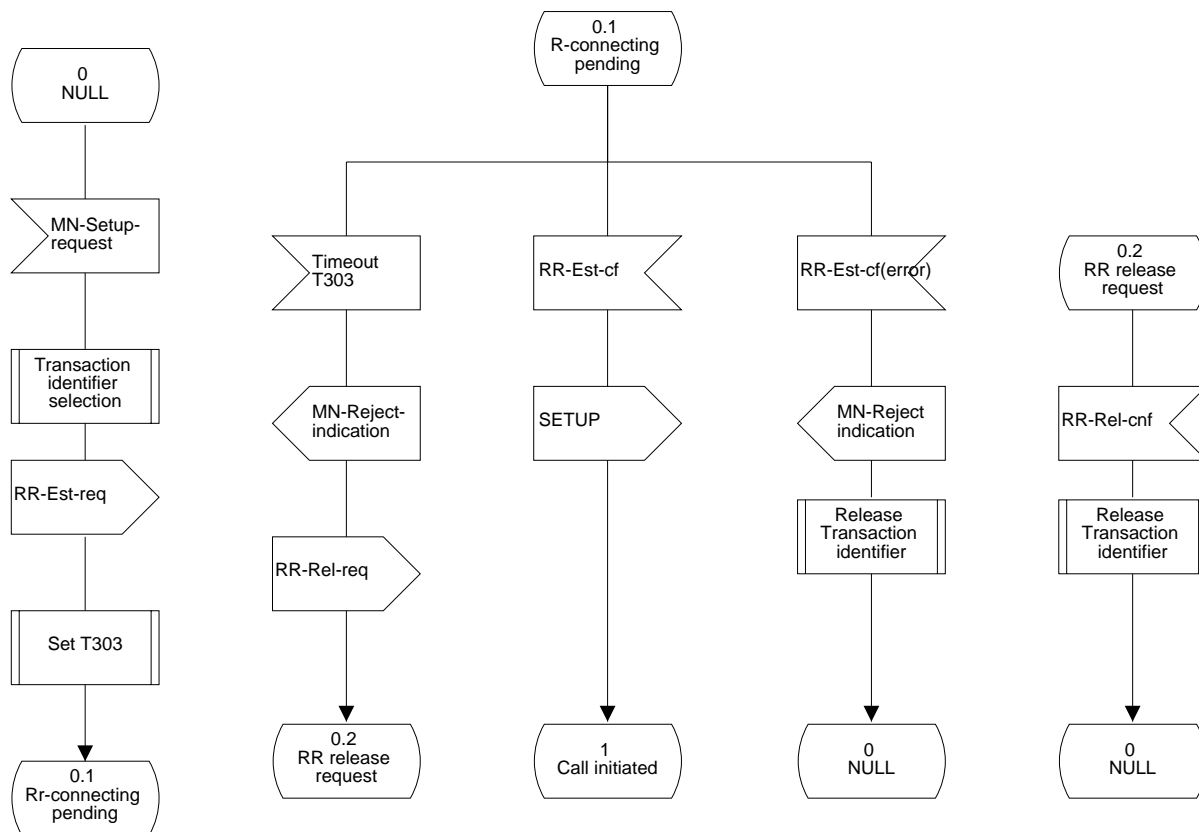


Figure 106: SDL of CC\_AT\_Protocol



Process CC\_AT\_Protocol

SE03262\_F107(15)

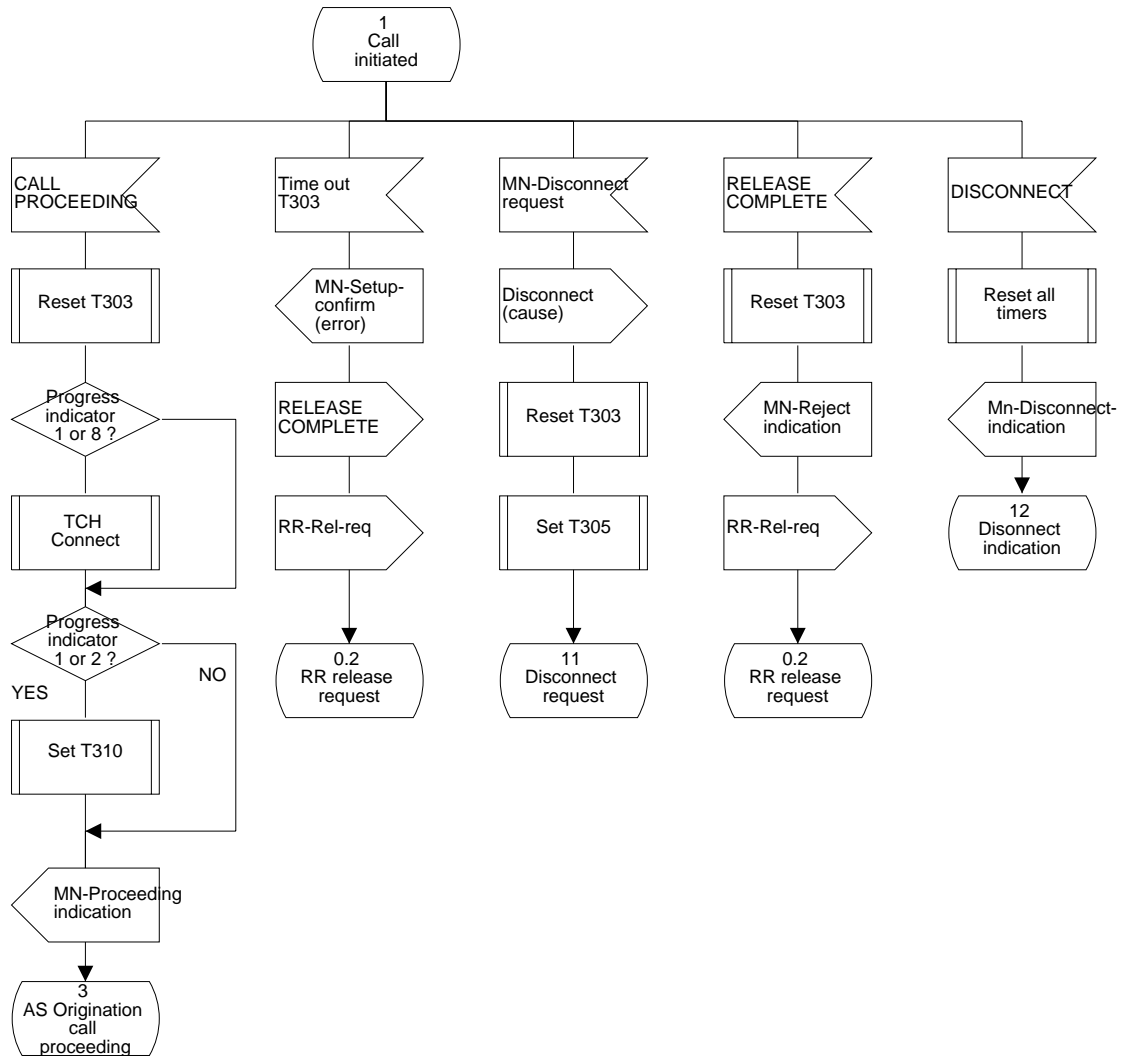


Figure 107: SDL of CC\_AT\_Protocol

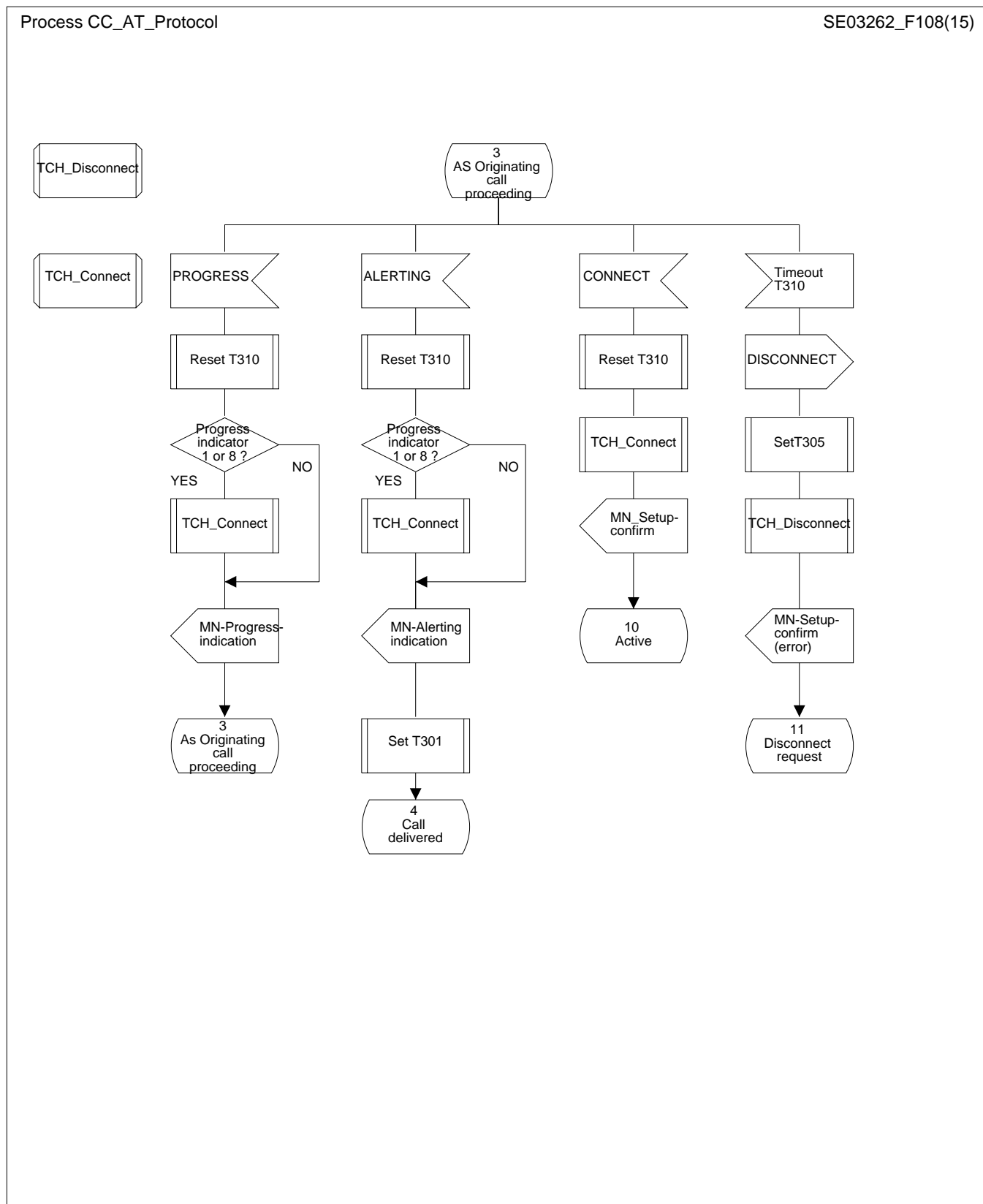


Figure 108: SDL of CC\_AT\_Protocol

Process CC\_AT\_Protocol

SE03262\_F109(15)

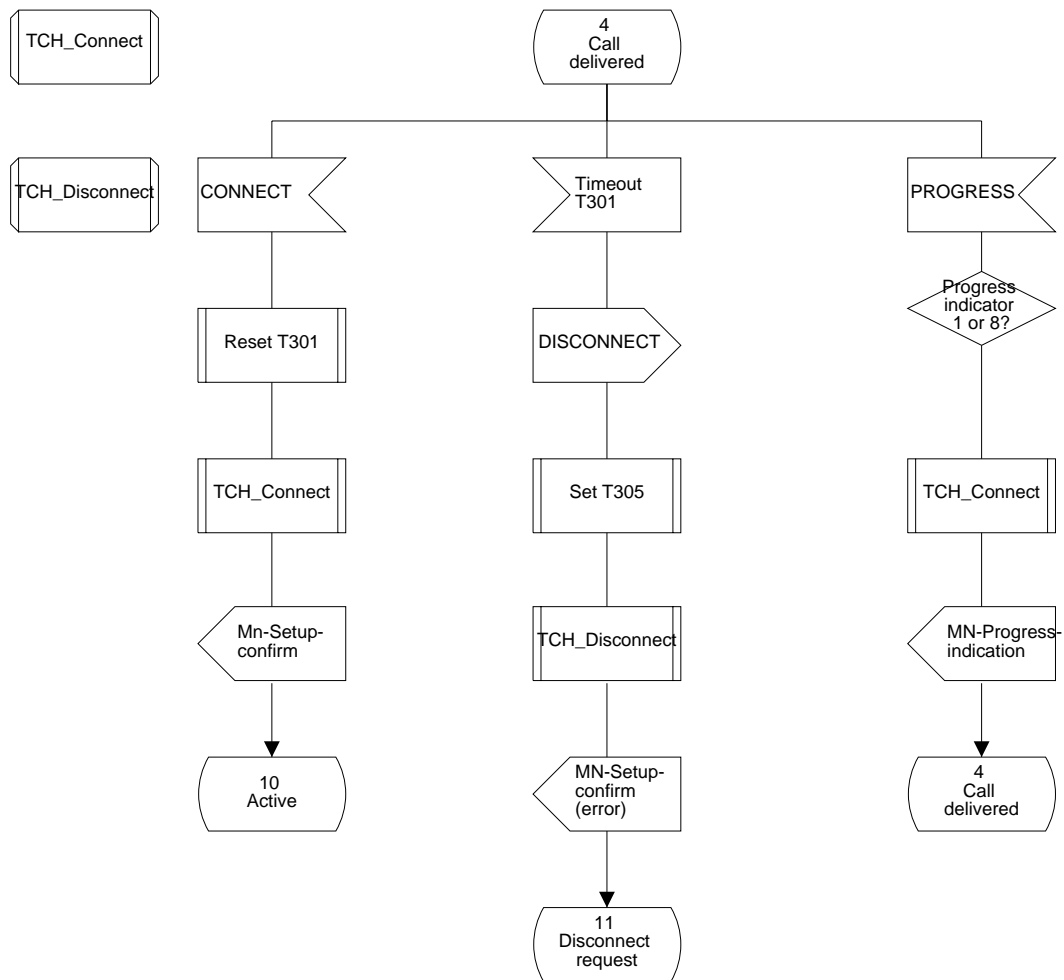


Figure 109: SDL of CC\_AT\_Protocol

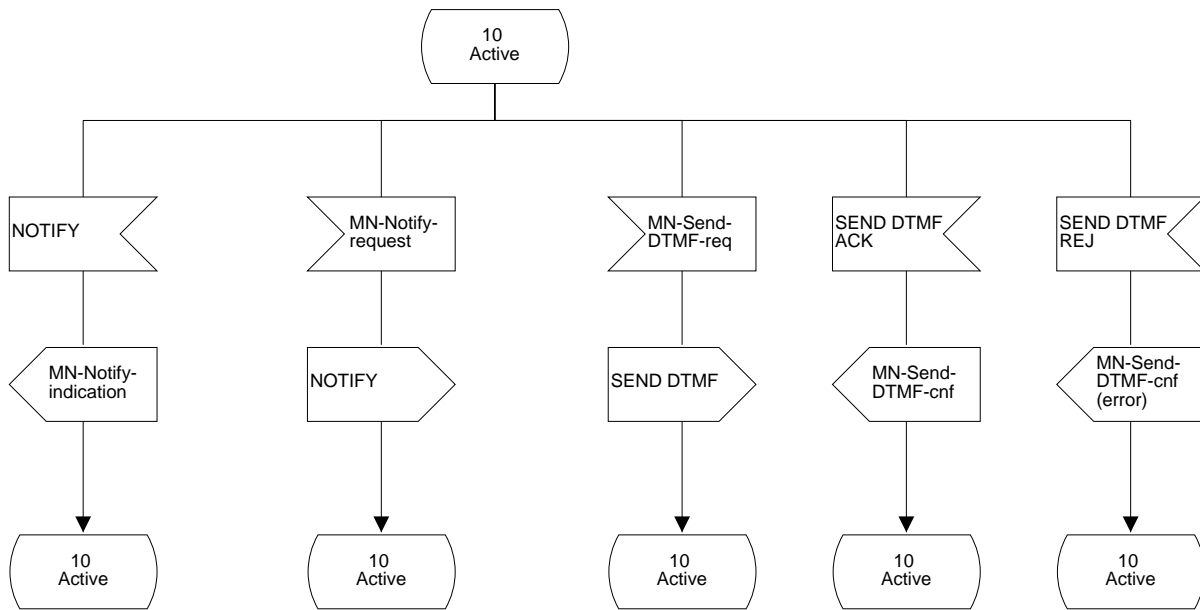


Figure 110: SDL of CC\_AT\_Protocol

Process CC\_AT\_Protocol

SE03262\_F111(15)

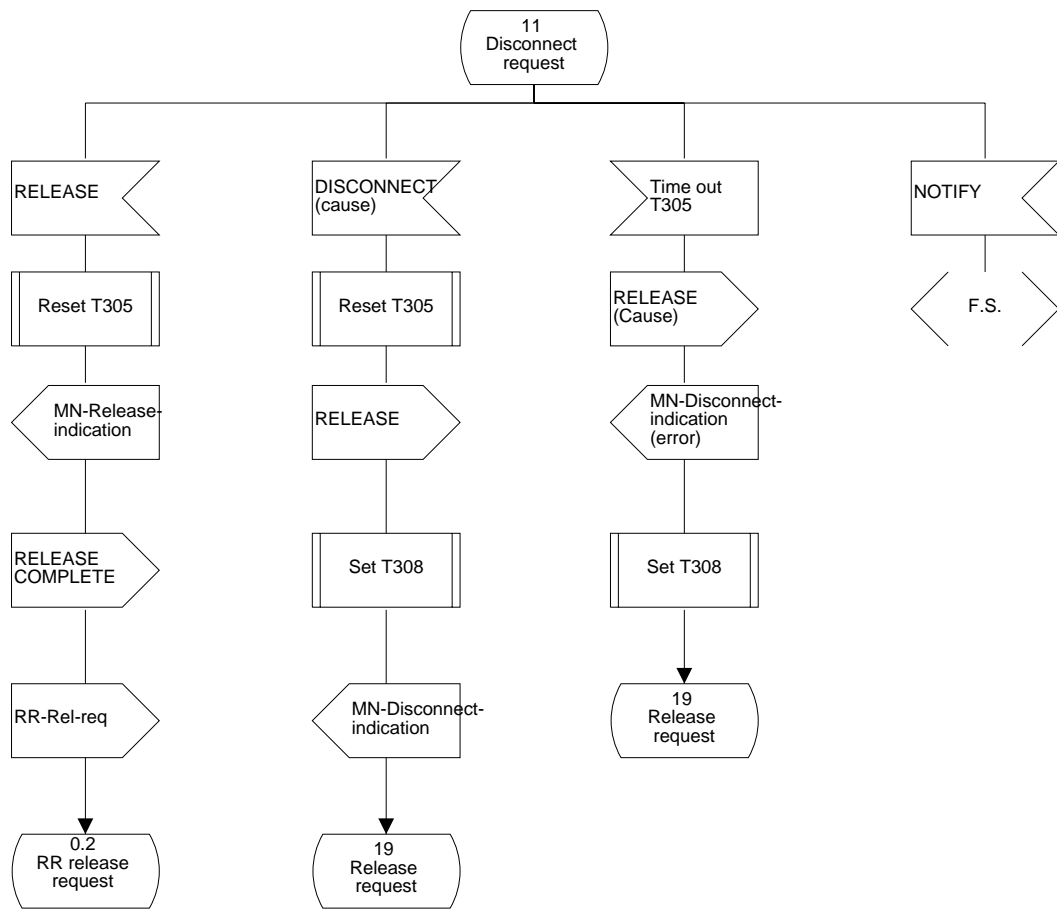


Figure 111: SDL of CC\_AT\_Protocol

Process CC\_AT\_Protocol

TCH\_Disconnect

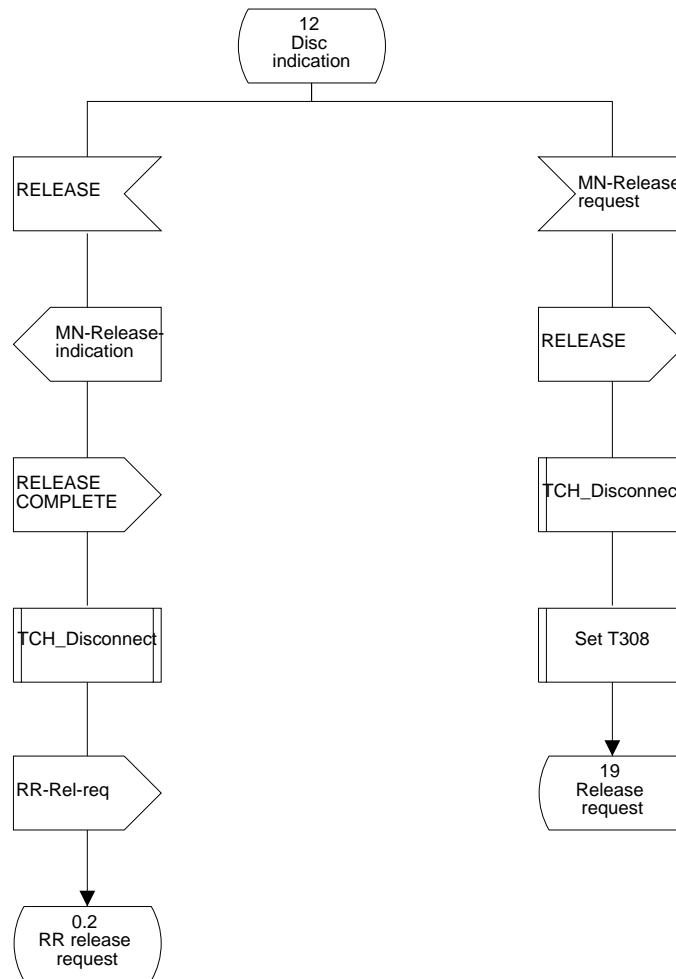


Figure 112: SDL of CC\_AT\_Protocol

Process CC\_AT\_Protocol

SE03262\_F113(15)

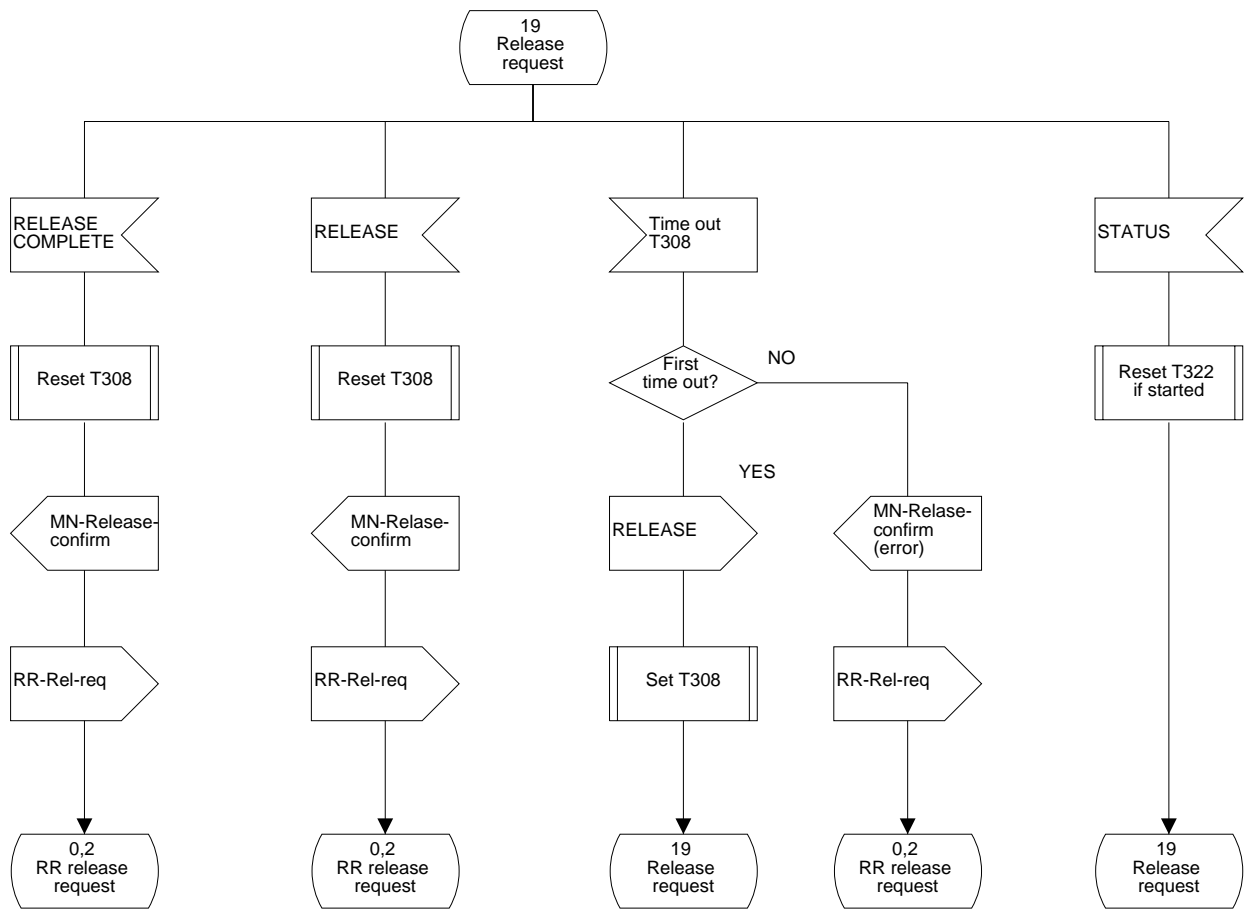


Figure 113: SDL of CC\_AT\_Protocol

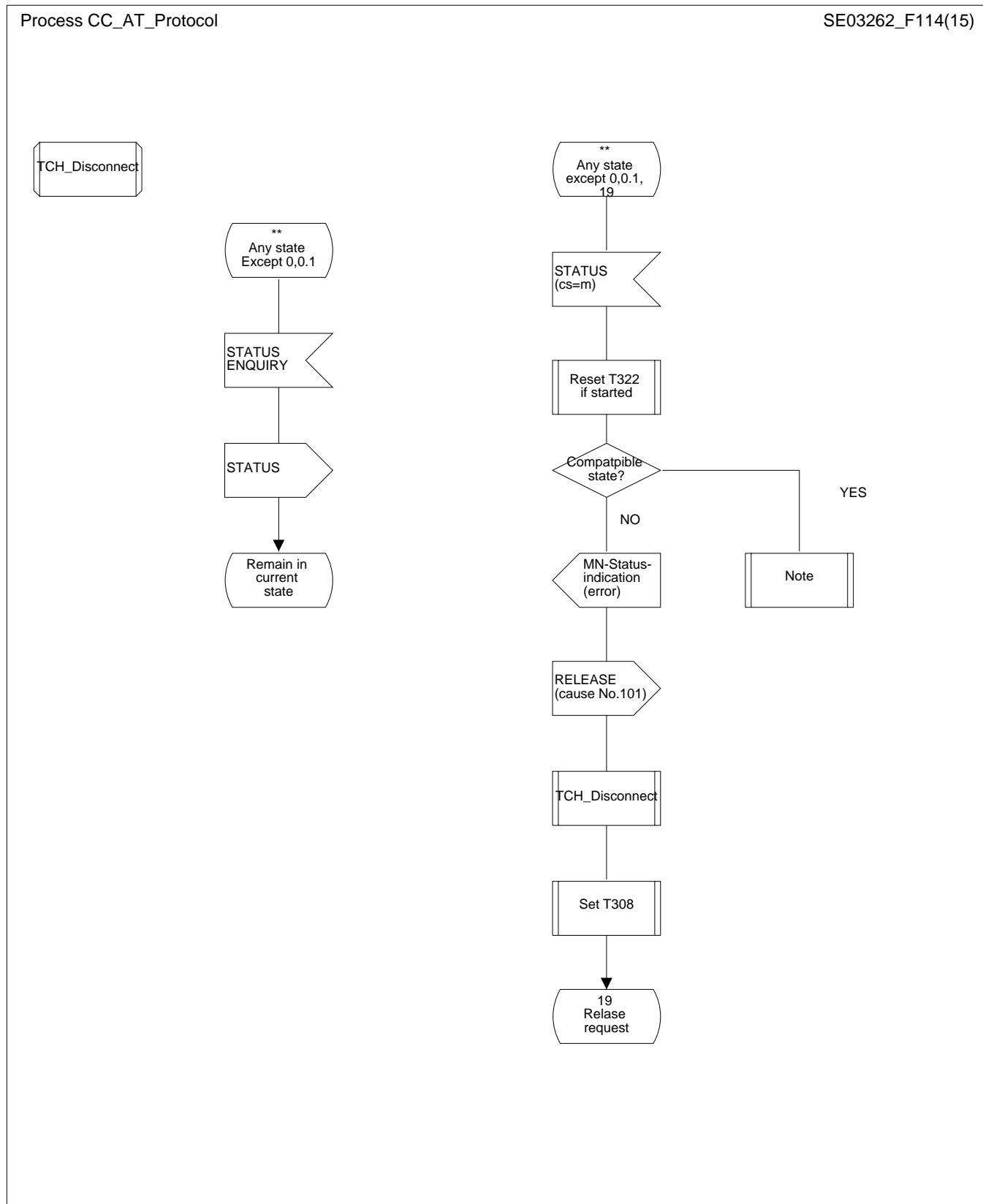


Figure 114: SDL of CC\_AT\_Protocol



Process CC\_AT\_Protocol

SE03262\_F115(15)

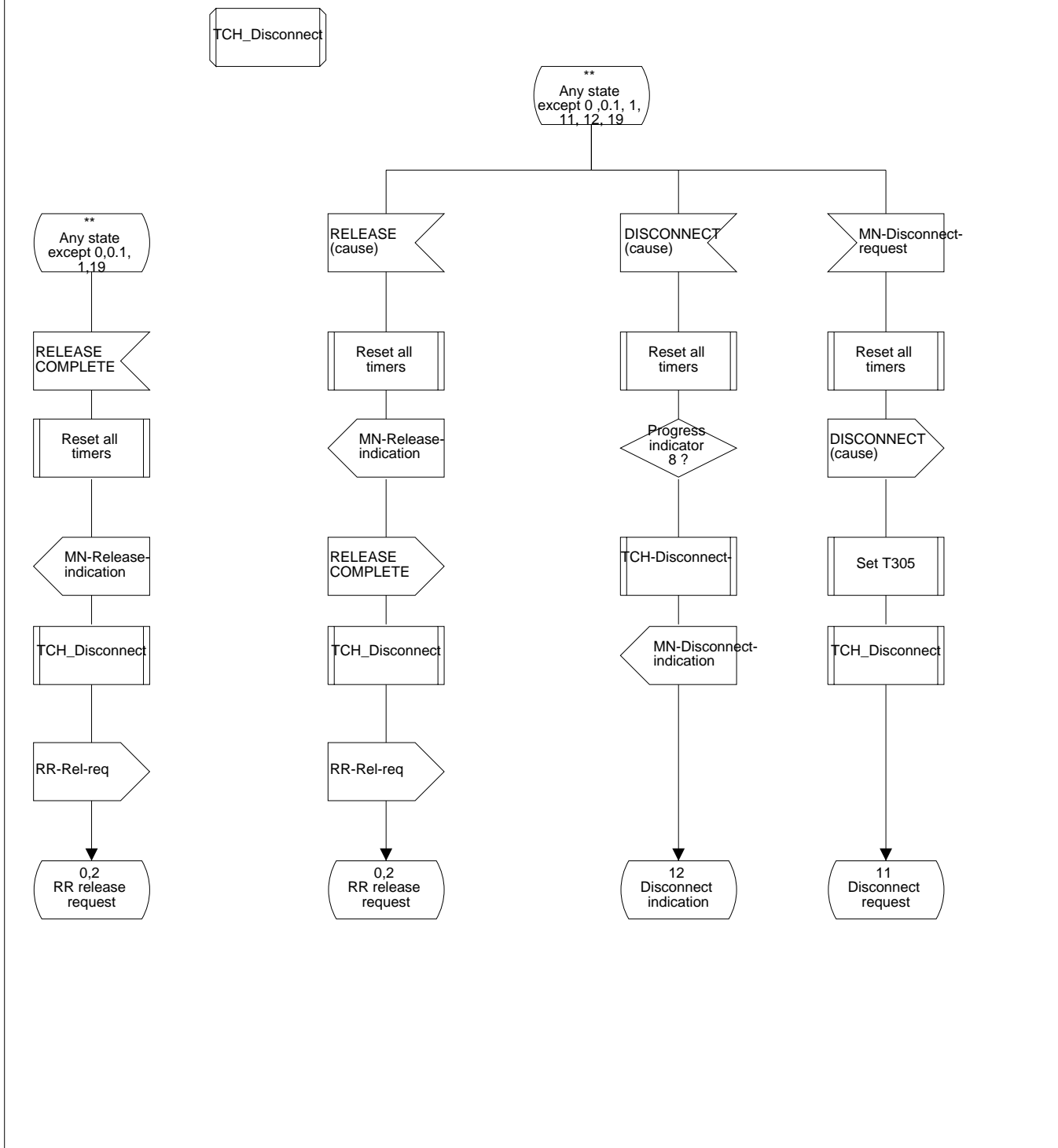


Figure 115: SDL of CC\_AT\_Protocol

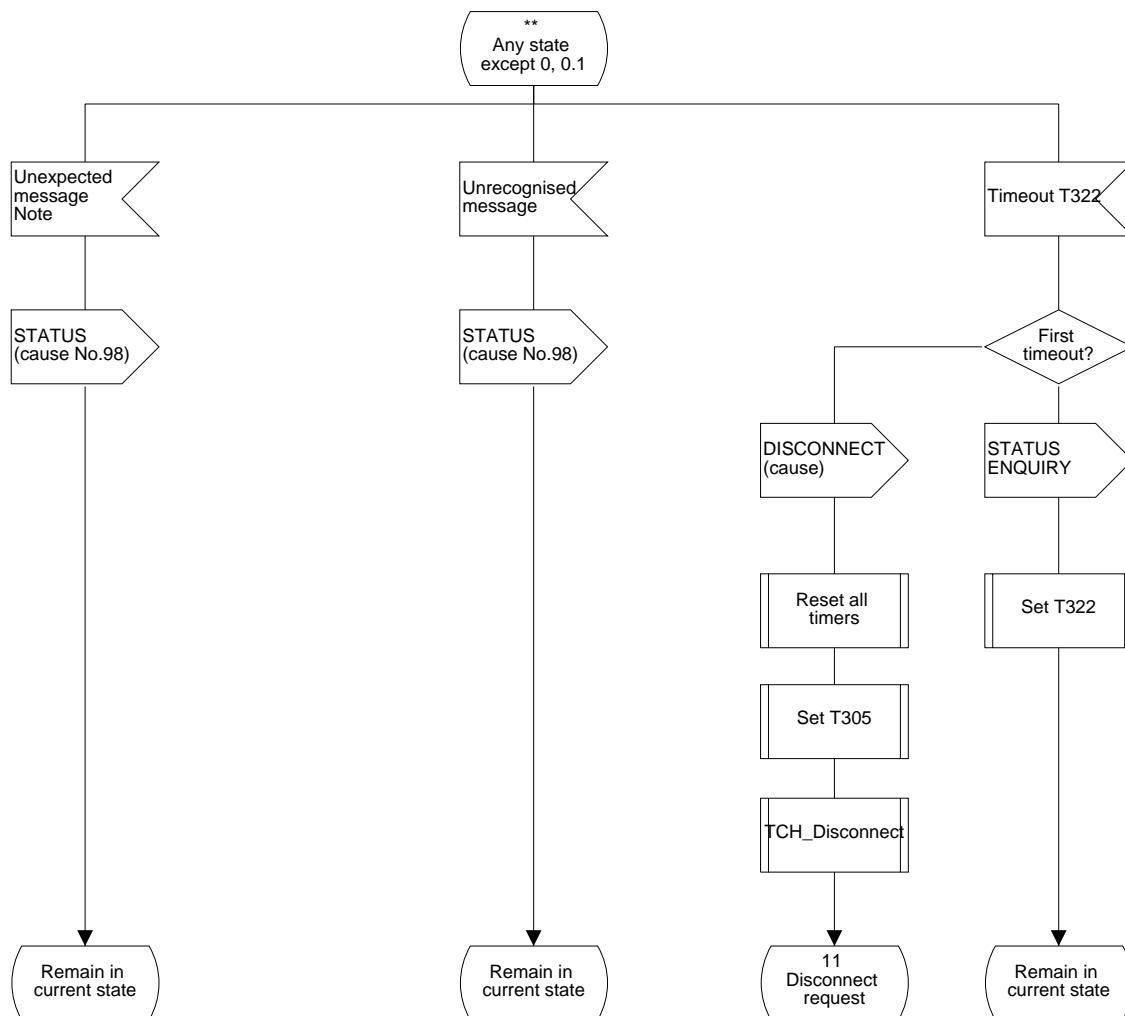


Figure 116: SDL of CC\_AT\_Protocol

Process CC\_AT\_Protocol

SE03262\_F117(15)

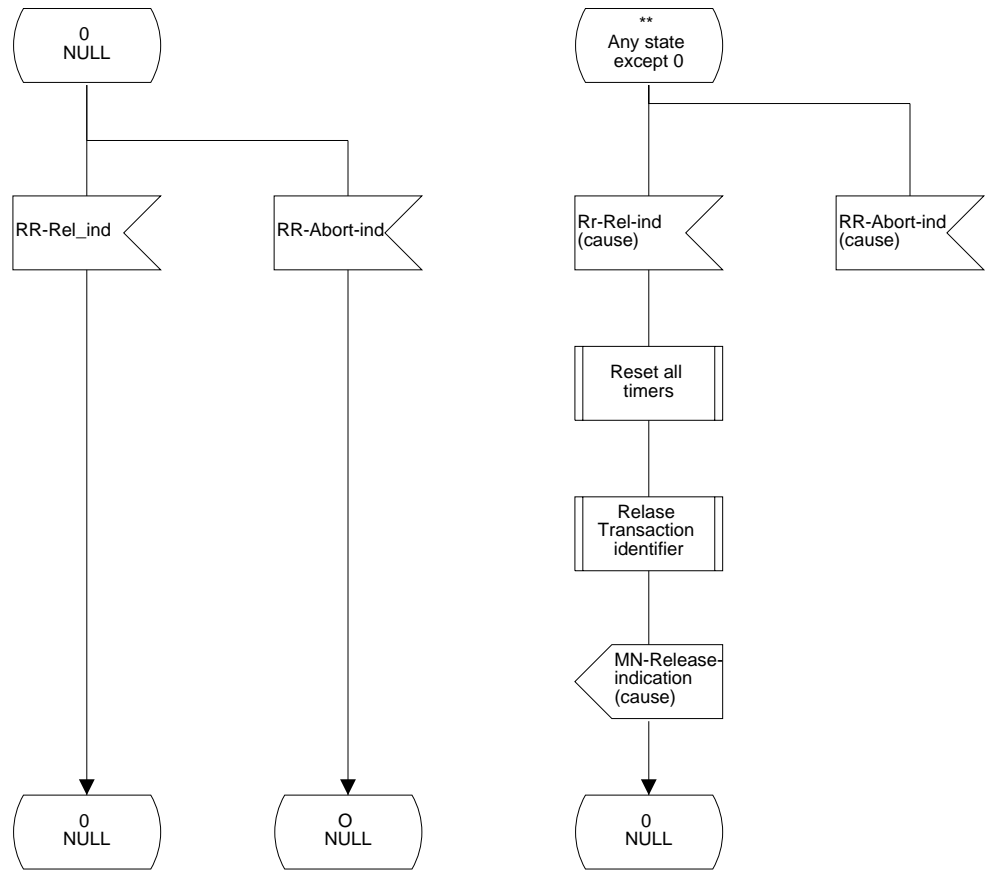
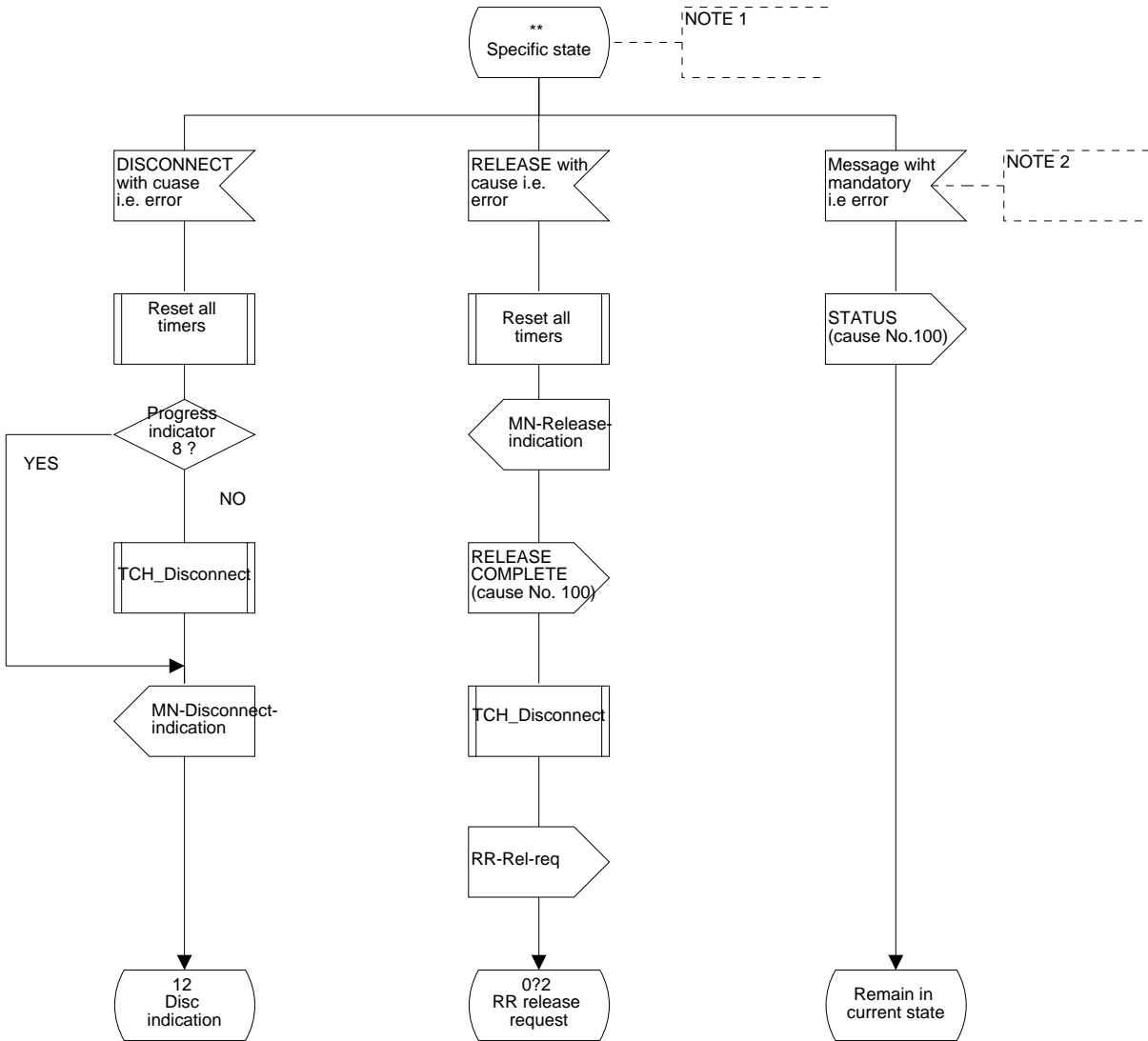


Figure 117: SDL of CC\_AT\_Protocol



NOTE 1: These messages are recognized by the user and expected messages in the state.  
 NOTE 2: Except SETUP, RELEASE COMPLETE and DISCONNECT

Figure 118: SDL of CC\_AT\_Protocol

Process CC\_AT\_Protocol

SE03262\_F119(15)

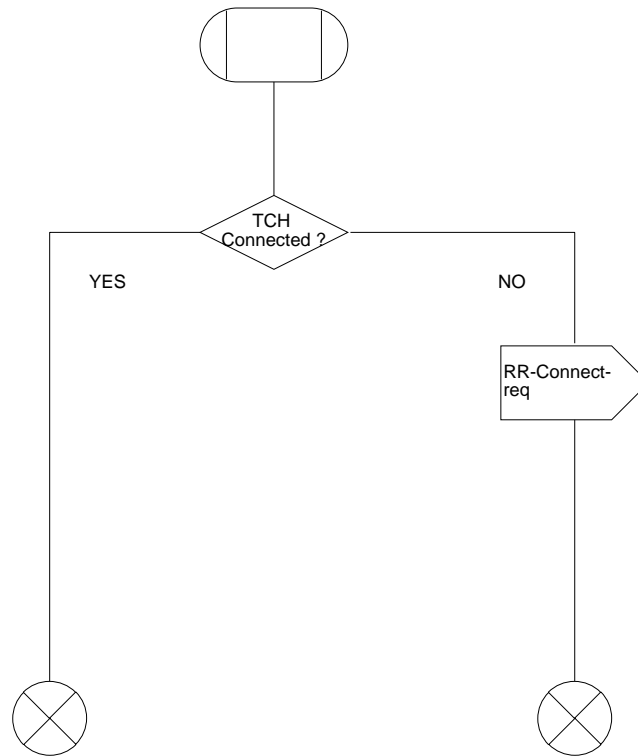


Figure 119: SDL of CC\_AT\_Protocol

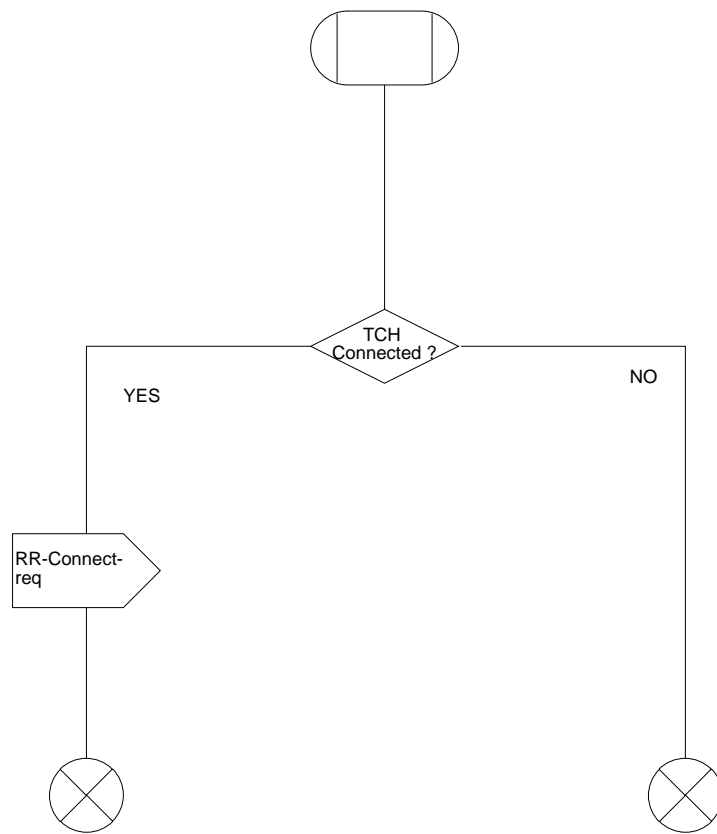


Figure 120: SDL of CC\_AT\_Protocol

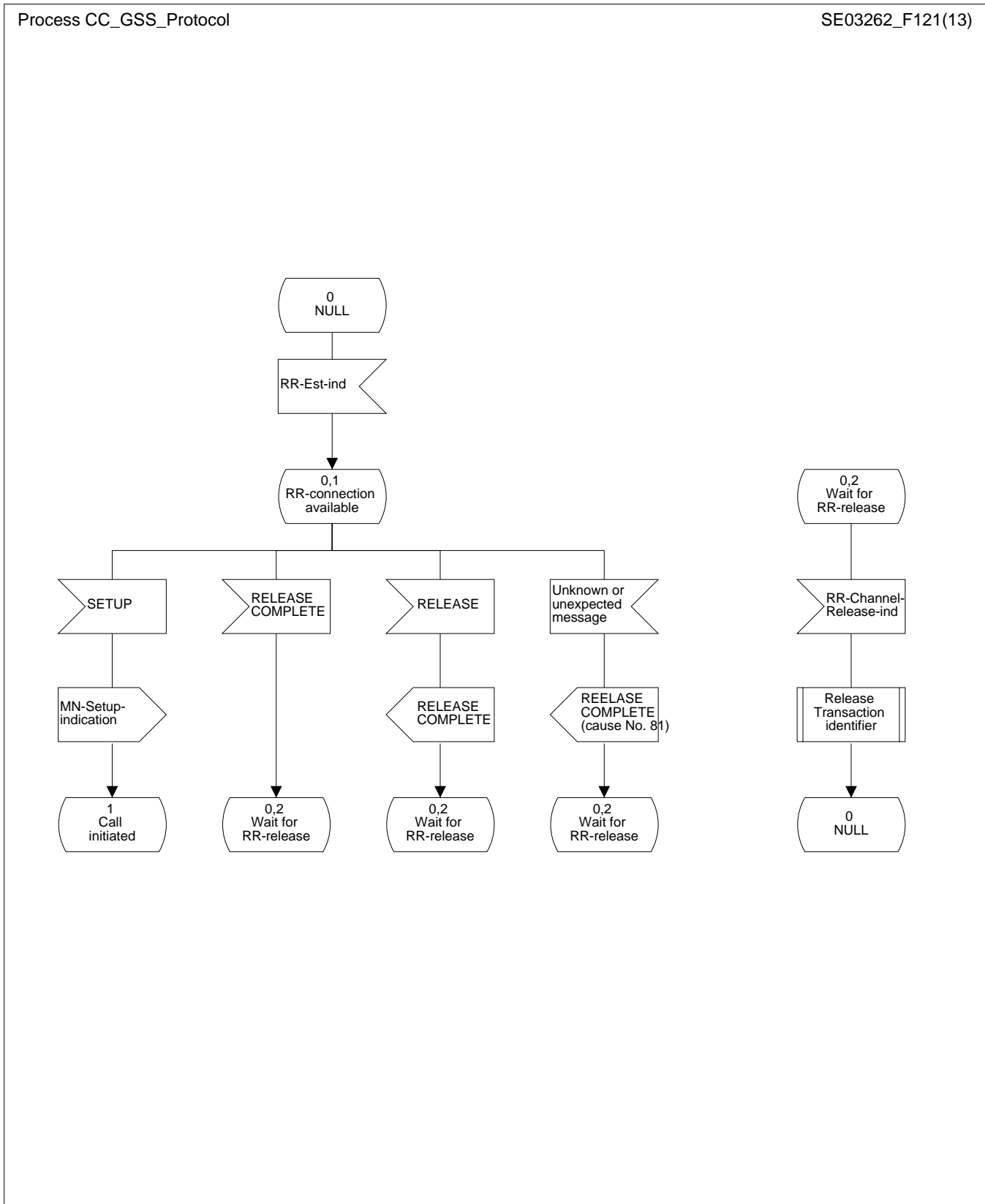


Figure 121: SDL of CC\_GSS\_Protocol

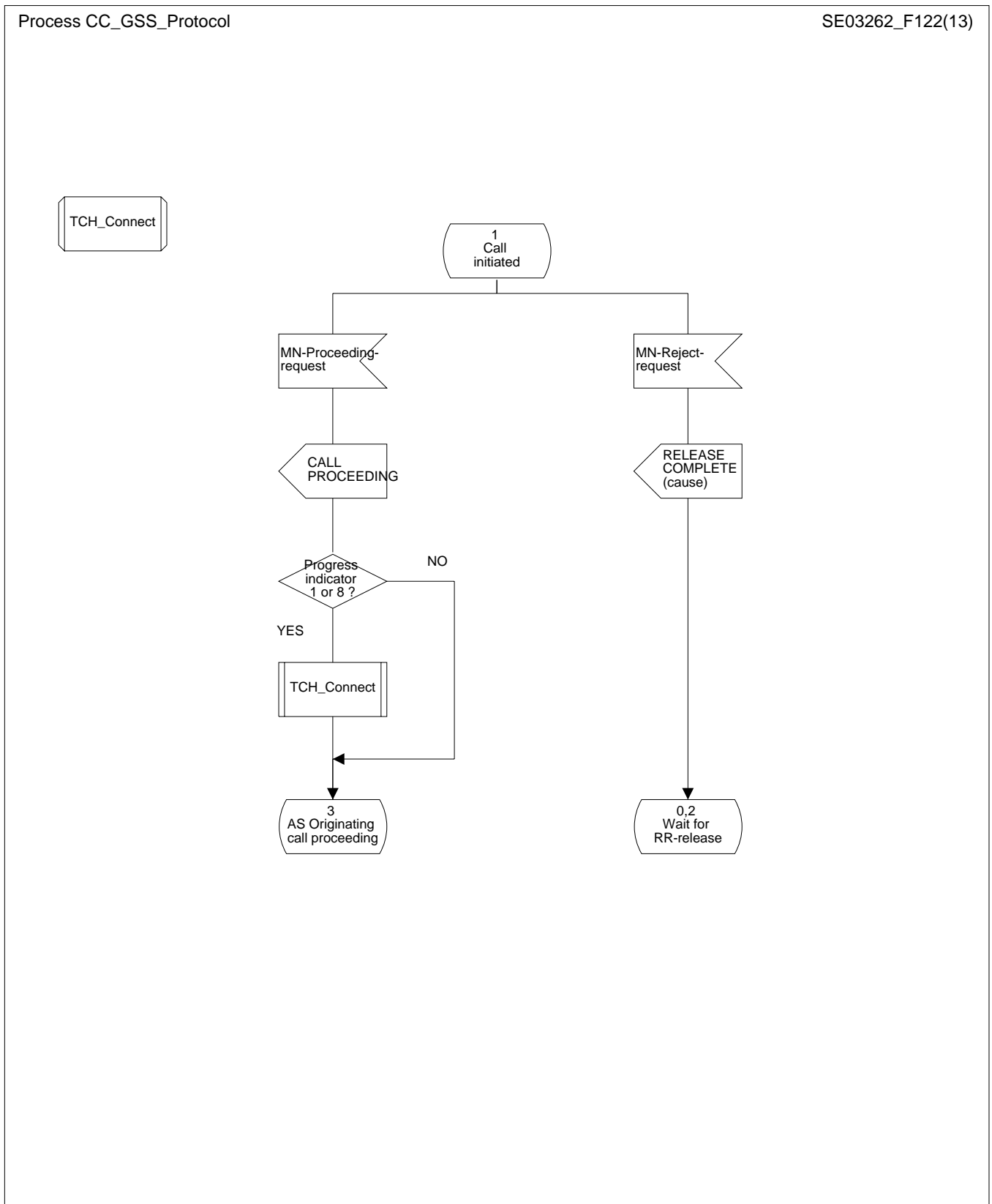


Figure 122: SDL of CC\_GSS\_Protocol



Process CC\_GSS\_Protocol

SE03262\_F123(13)

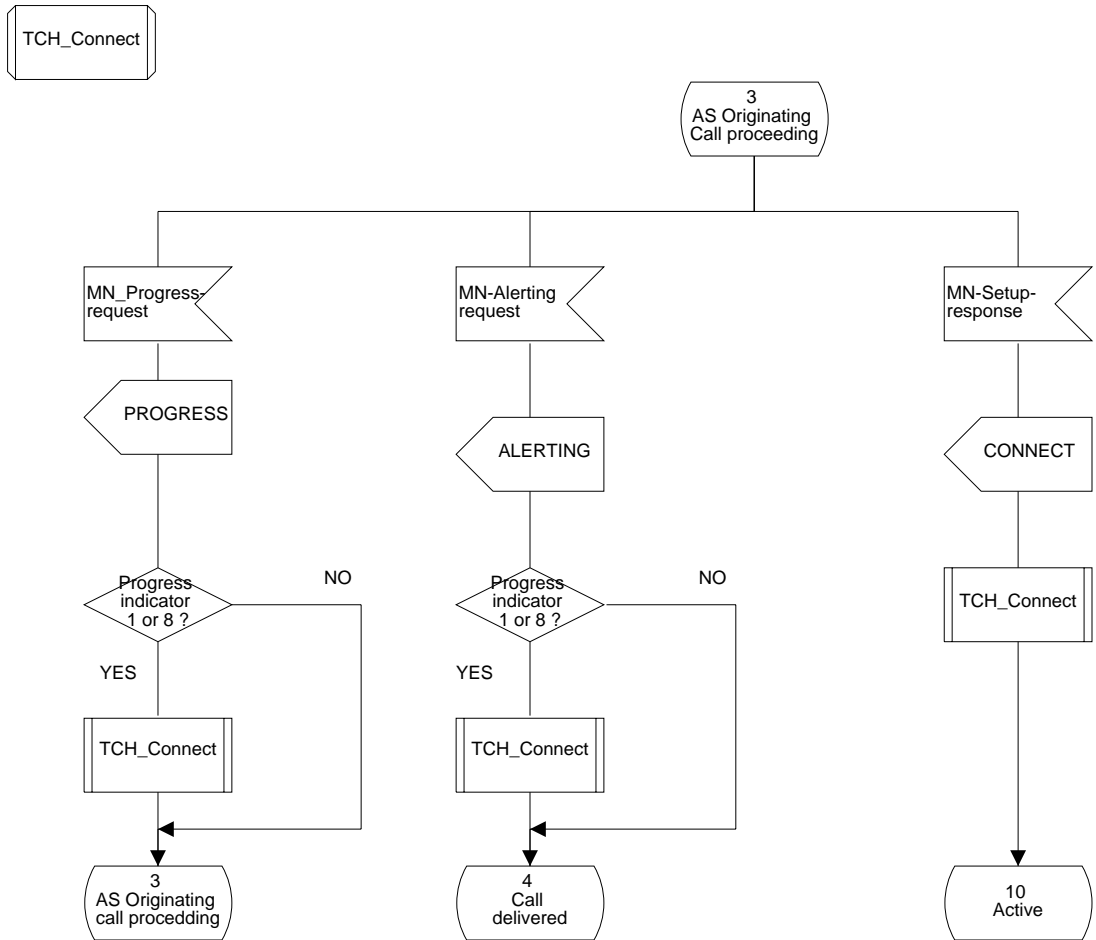


Figure 123: SDL of CC\_GSS\_Protocol

TCH\_Connect

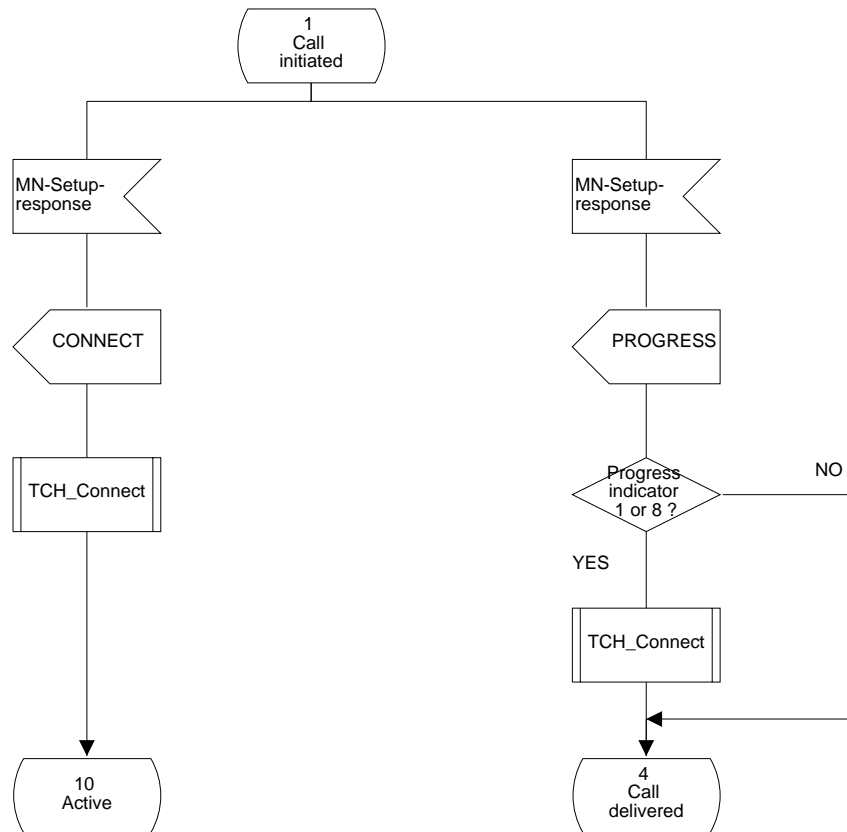


Figure 124: SDL of CC\_GSS\_Protocol

Process CC\_GSS\_Protocol

SE03262\_F125(13)

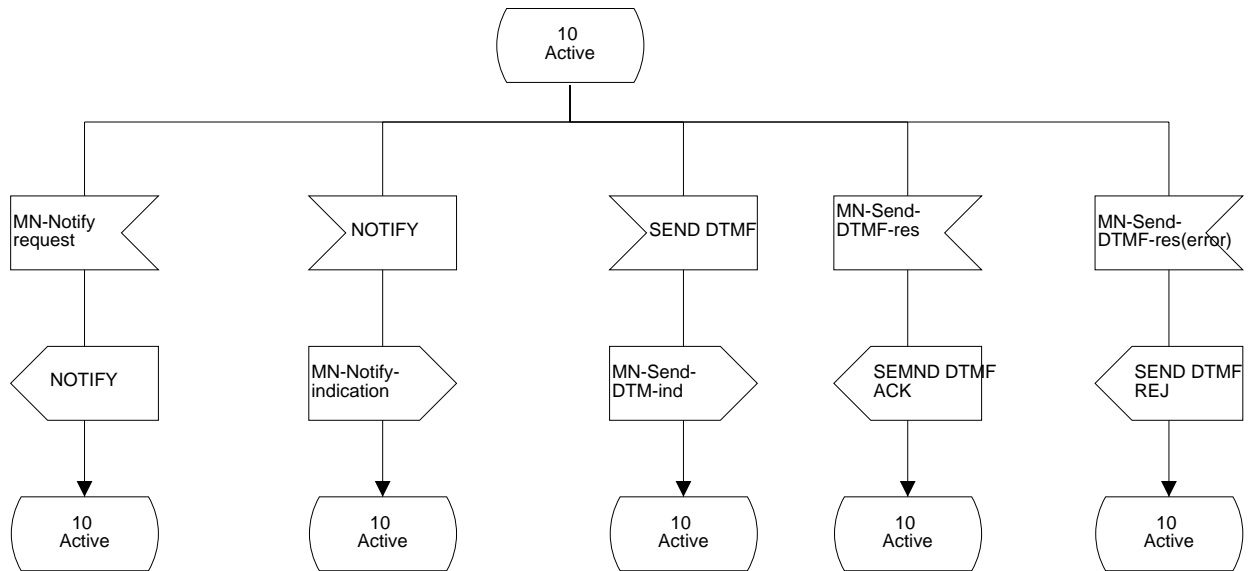


Figure 125: SDL of CC\_GSS\_Protocol

Process CC\_GSS\_Protocol

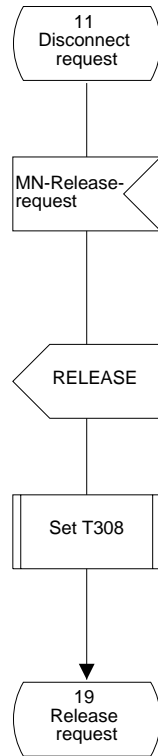


Figure 126: SDL of CC\_GSS\_Protocol

Process CC\_GSS\_Protocol

SE03262\_F127(13)

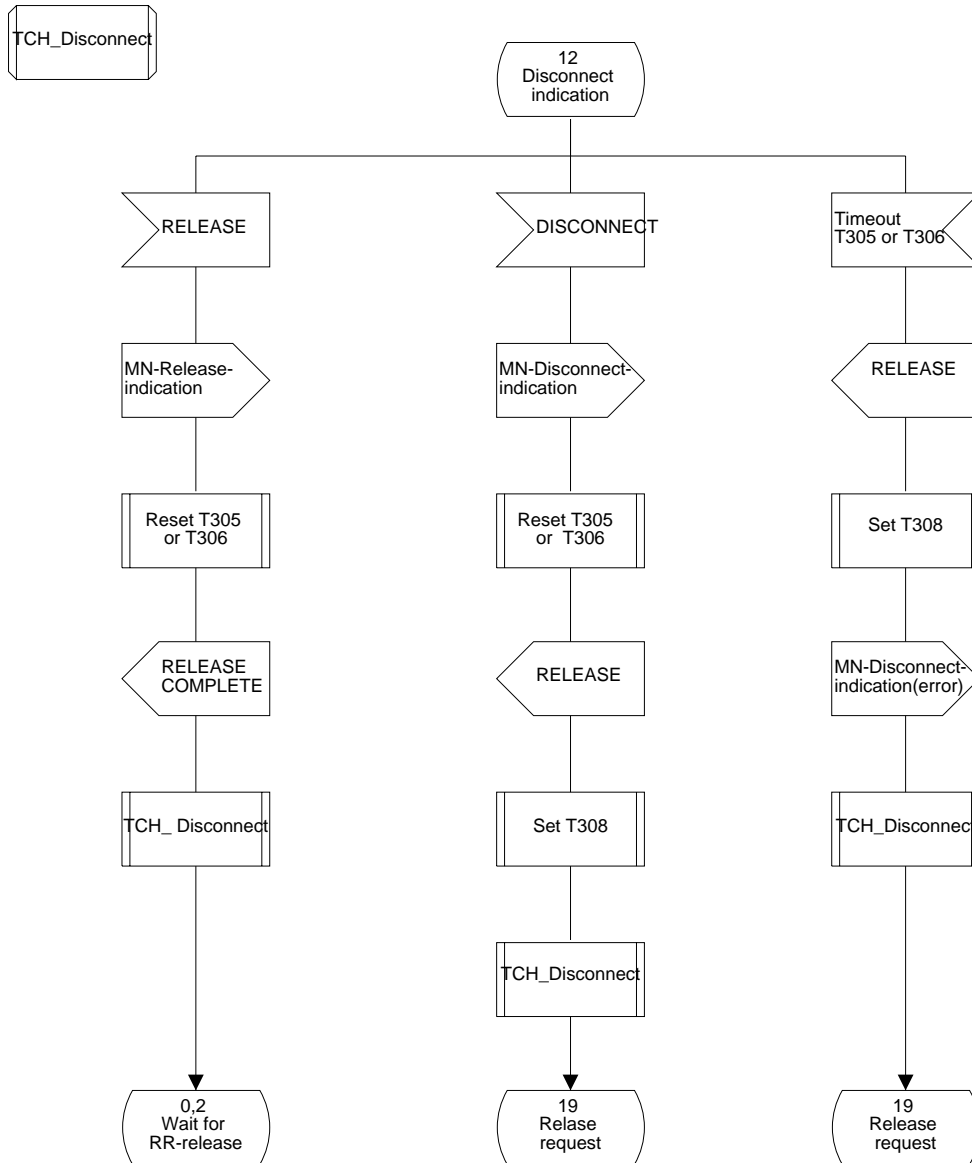


Figure 127: SDL of CC\_GSS\_Protocol

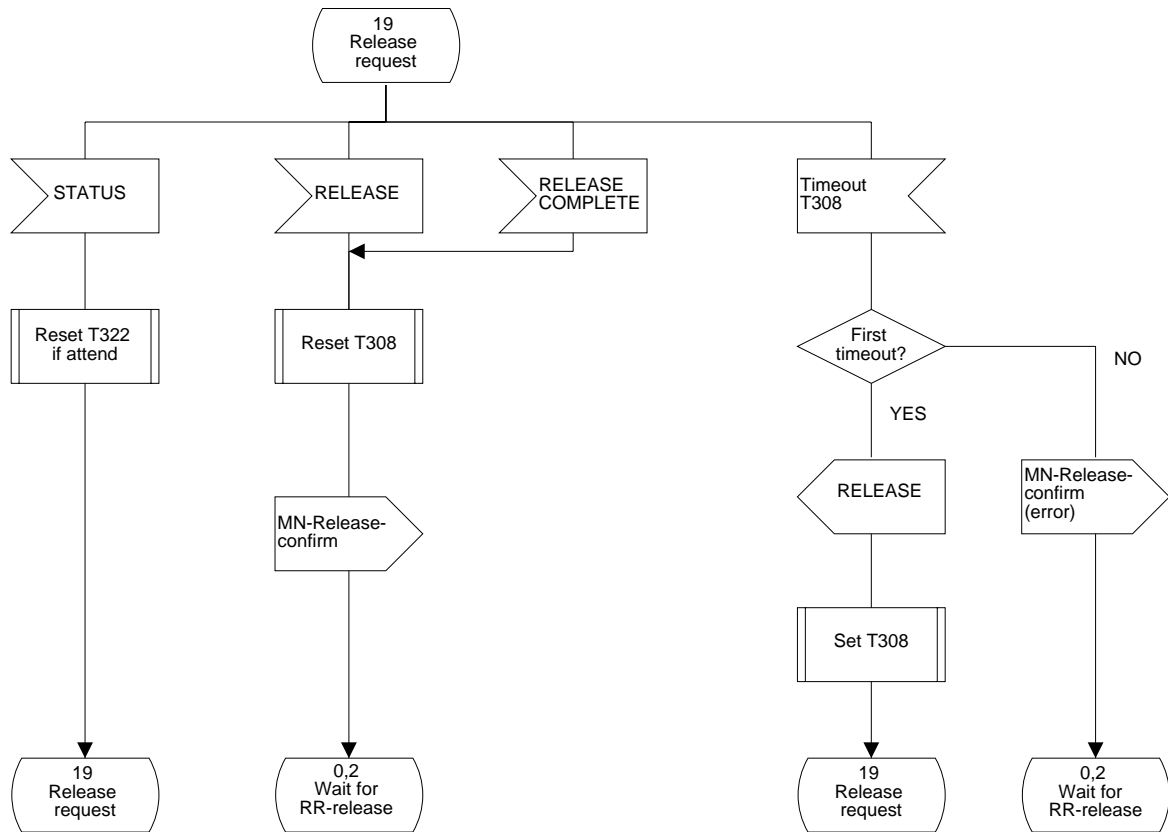
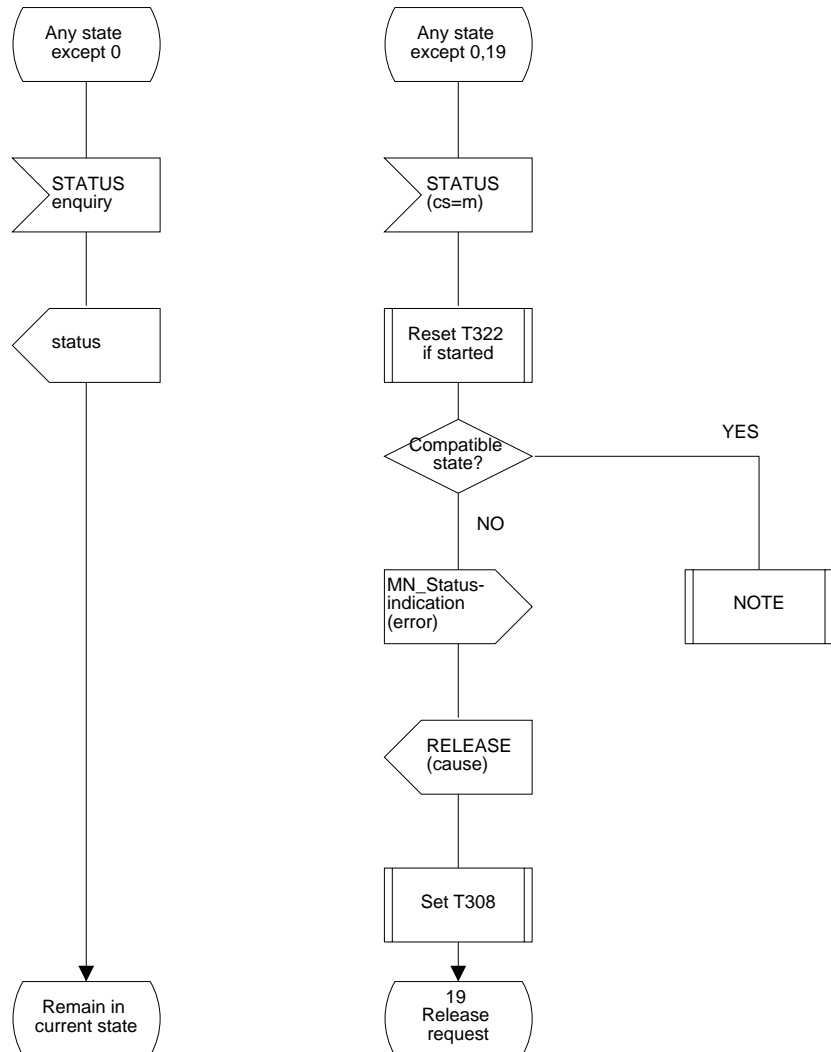


Figure 128: SDL of CC\_GSS\_Protocol

Process CC\_GSS\_Protocol

SE03262\_F129(13)



NOTE: Action on receipt of status indicating a compatible call state is implementation dependent (see TFTS 04,08 section 4.5.2.2)

Figure 129: SDL of CC\_GSS\_Protocol

TCH\_Disconnect

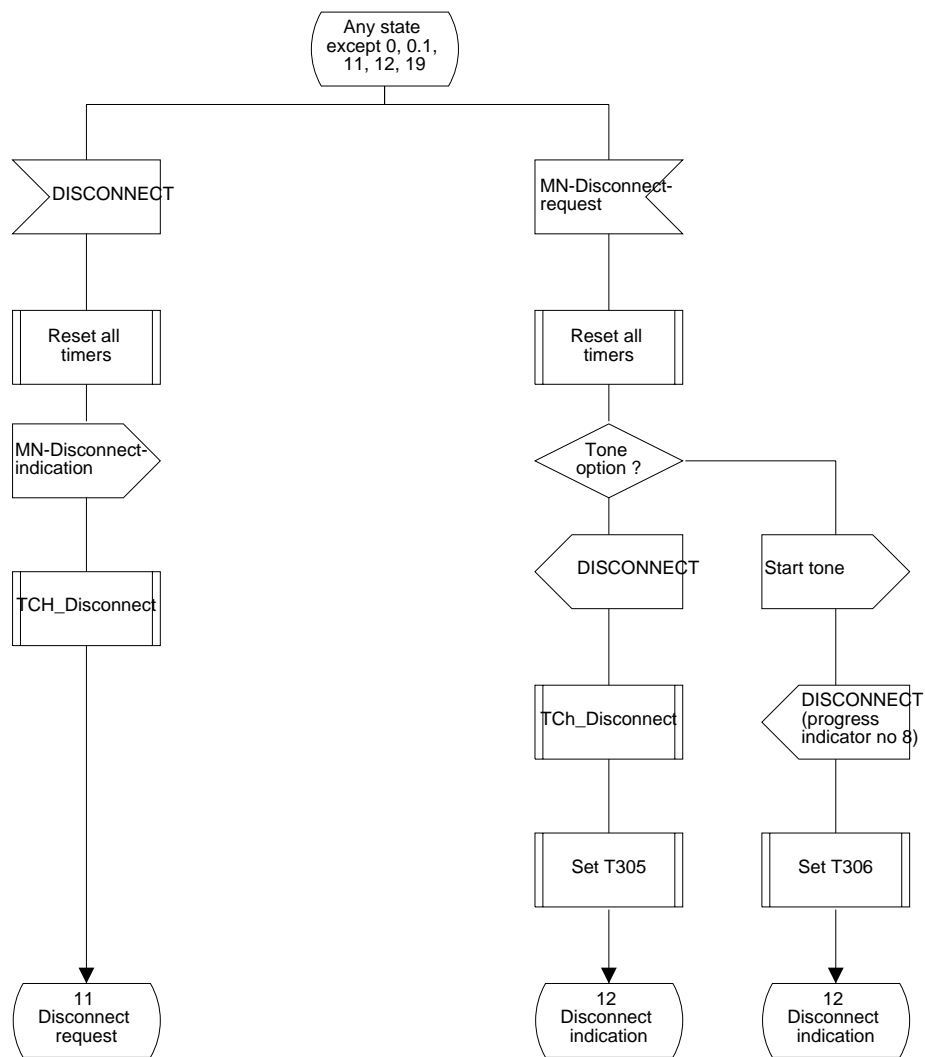


Figure 130: SDL of CC\_GSS\_Protocol



Process CC\_GSS\_Protocol

SE03262\_F131(13)

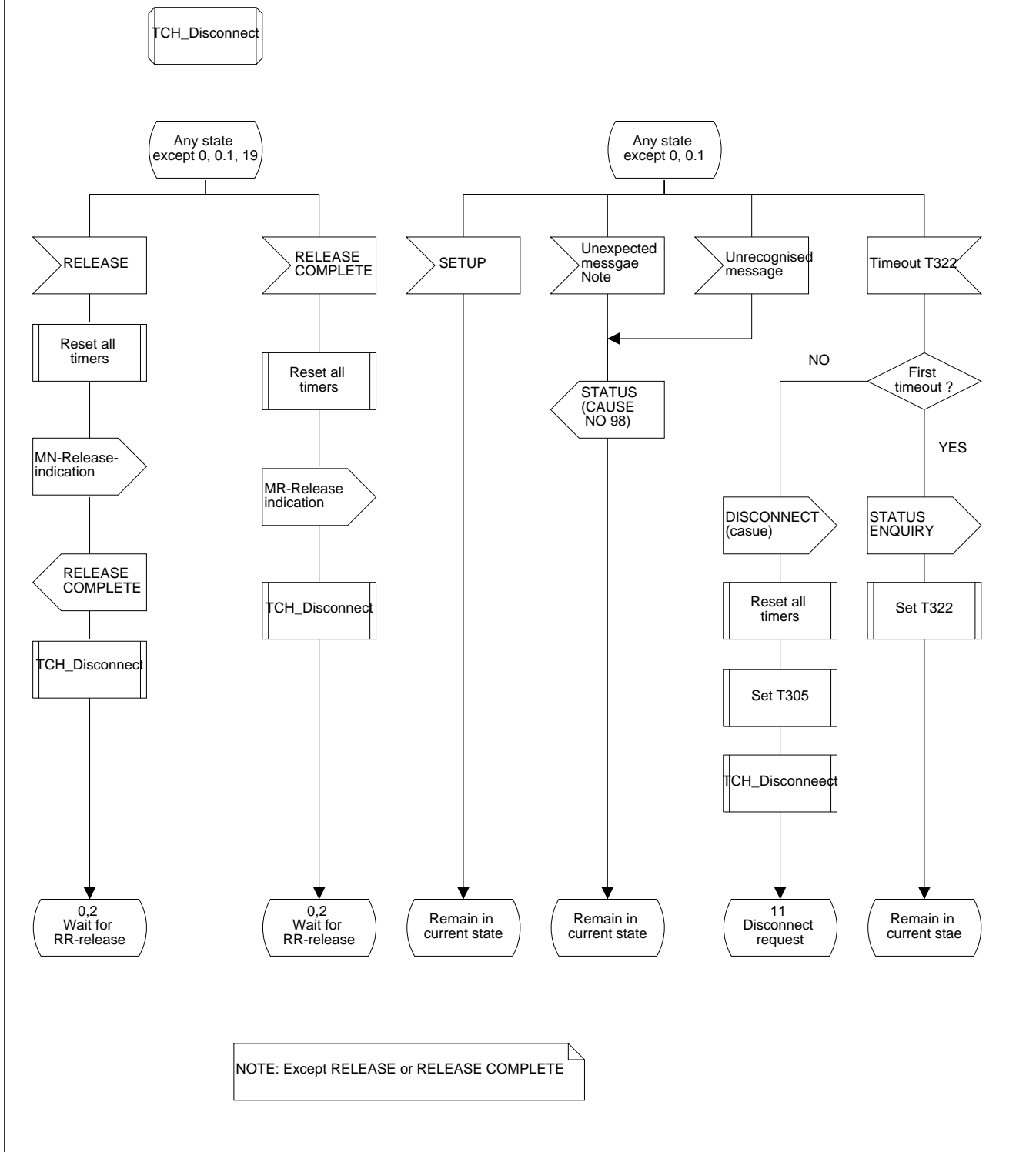


Figure 131: SDL of CC\_GSS\_Protocol

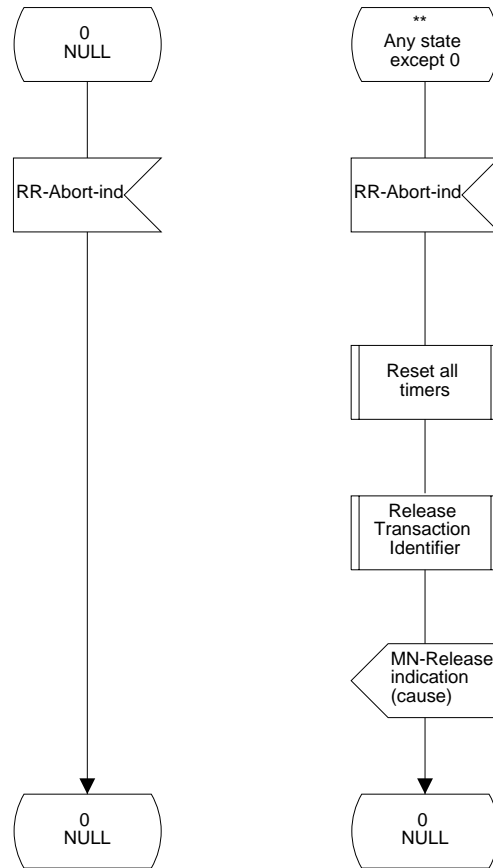


Figure 132: SDL of CC\_GSS\_Protocol

Process CC\_GSS\_Protocol

SE03262\_F133(13)

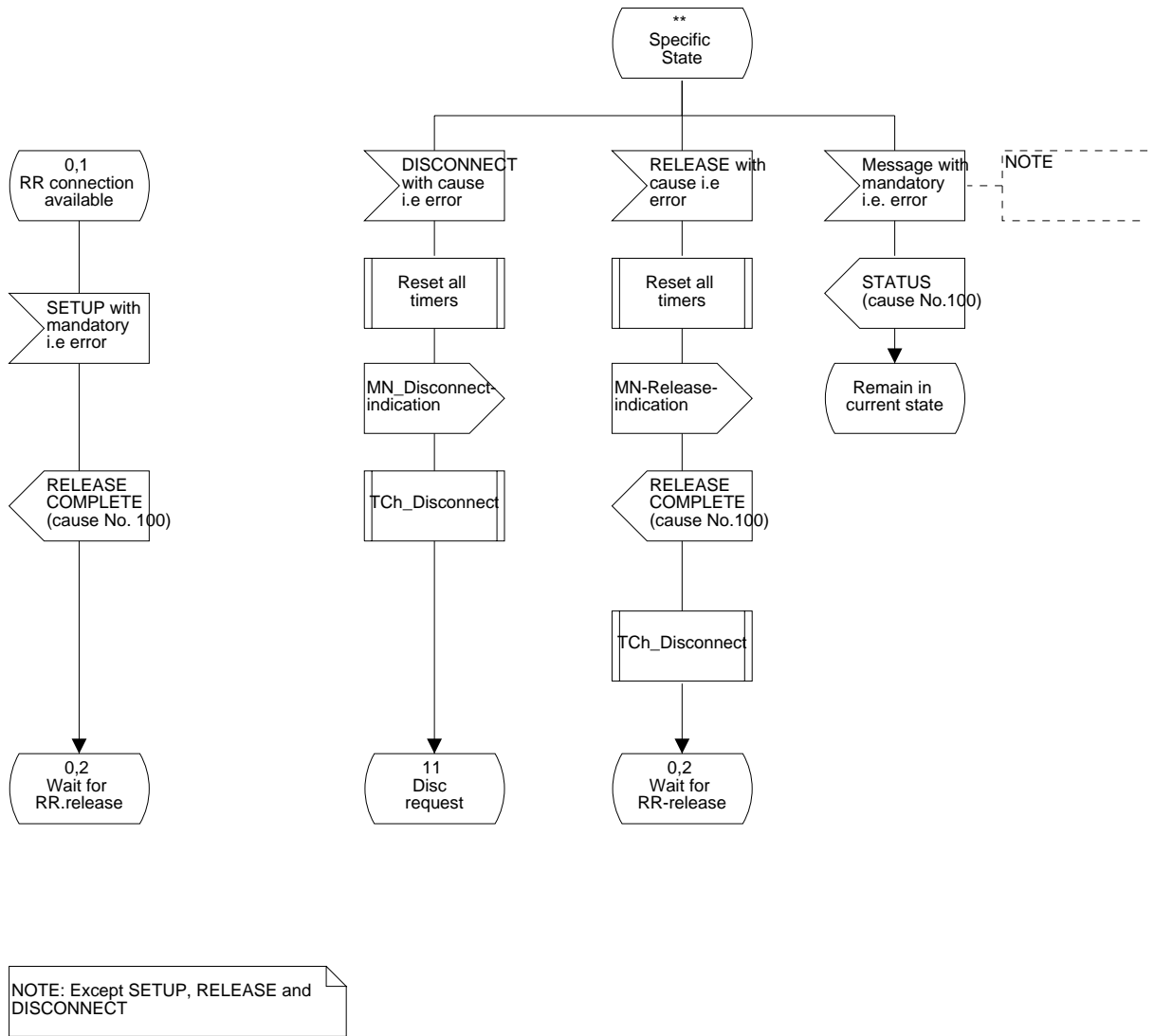


Figure 133: SDL of CC\_GSS\_Protocol

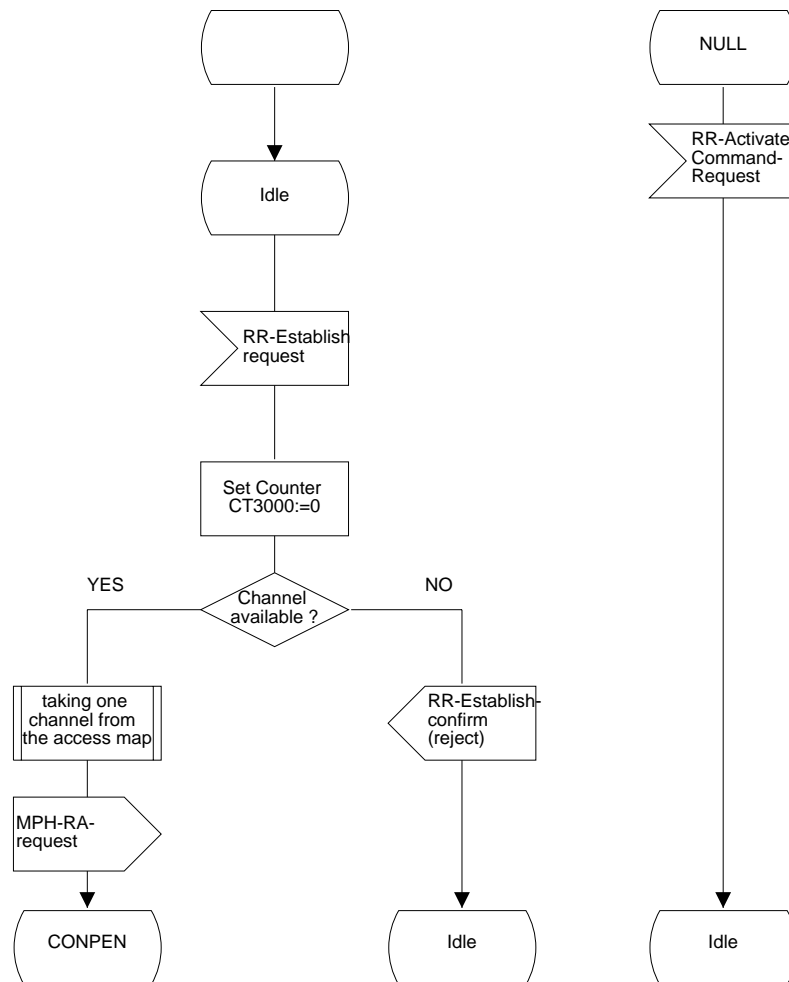


Figure 134: SDL of RR\_AT\_Protocol

Process RR\_AT\_Protocol

SE03262\_F135(17)

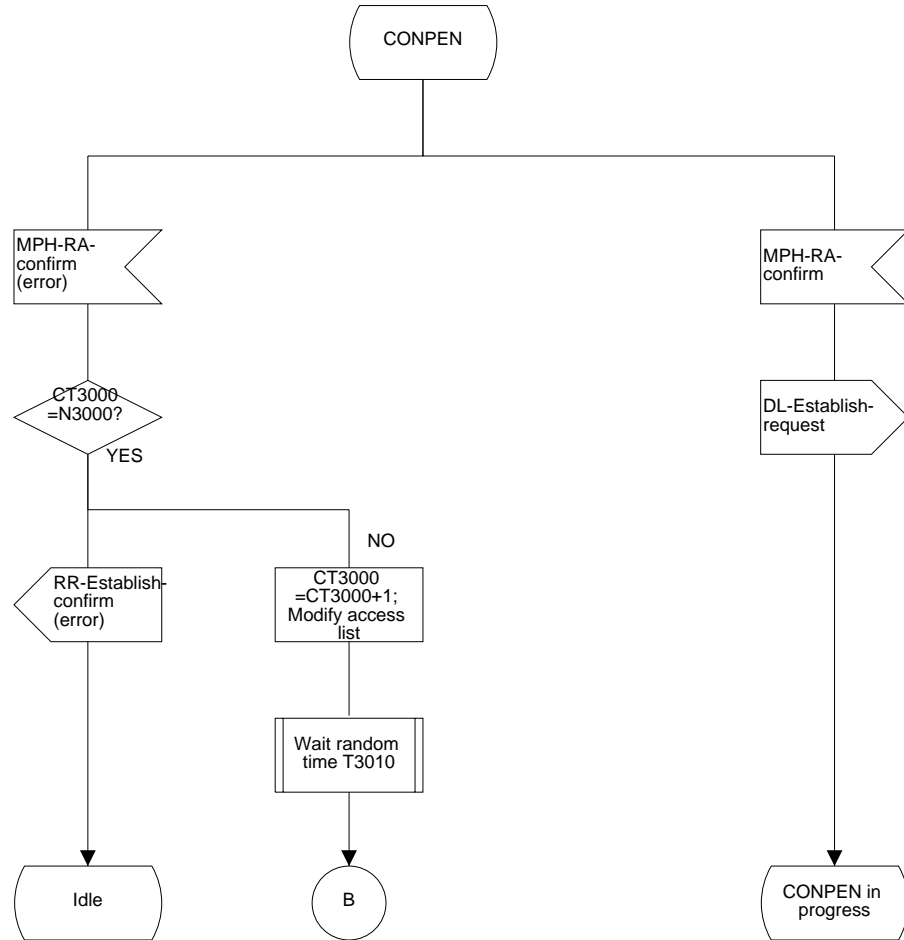


Figure 135: SDL of RR\_AT\_Protocol

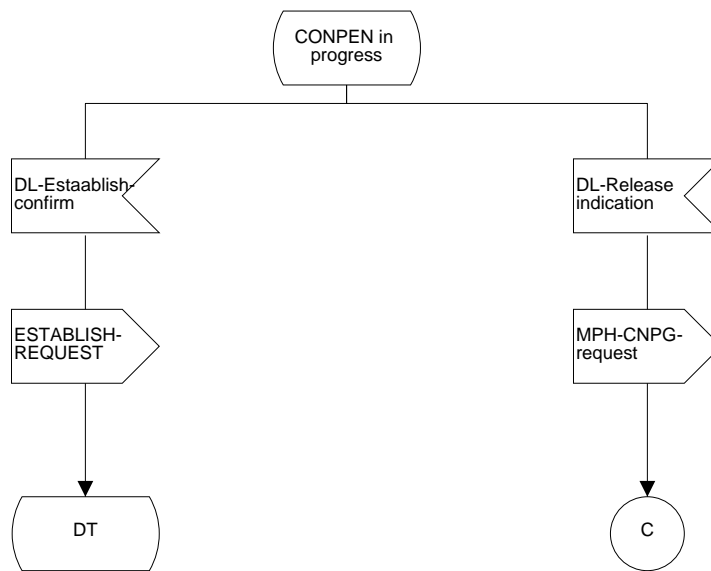


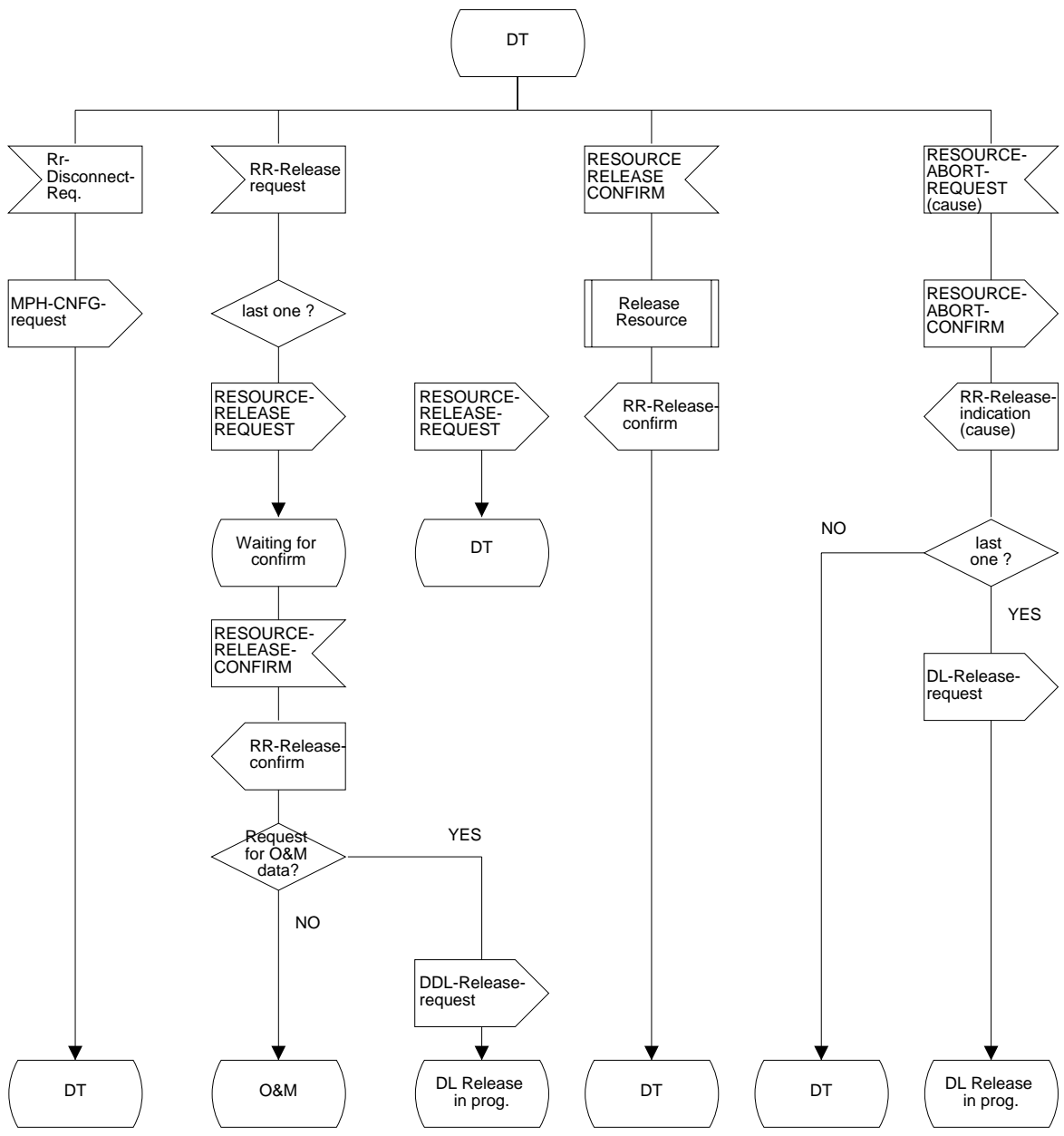
Figure 136: SDL of RR\_AT\_Protocol

Process RR\_AT\_Protocol

SE03262\_F137(17)



Figure 137: SDL of RR\_AT\_Protocol



NOTE: "Last one" includes:  
 - no channel established; and  
 - no channel requested.

Figure 138: SDL of RR\_AT\_Protocol



Process RR\_AT\_Protocol

SE03262\_F139(17)

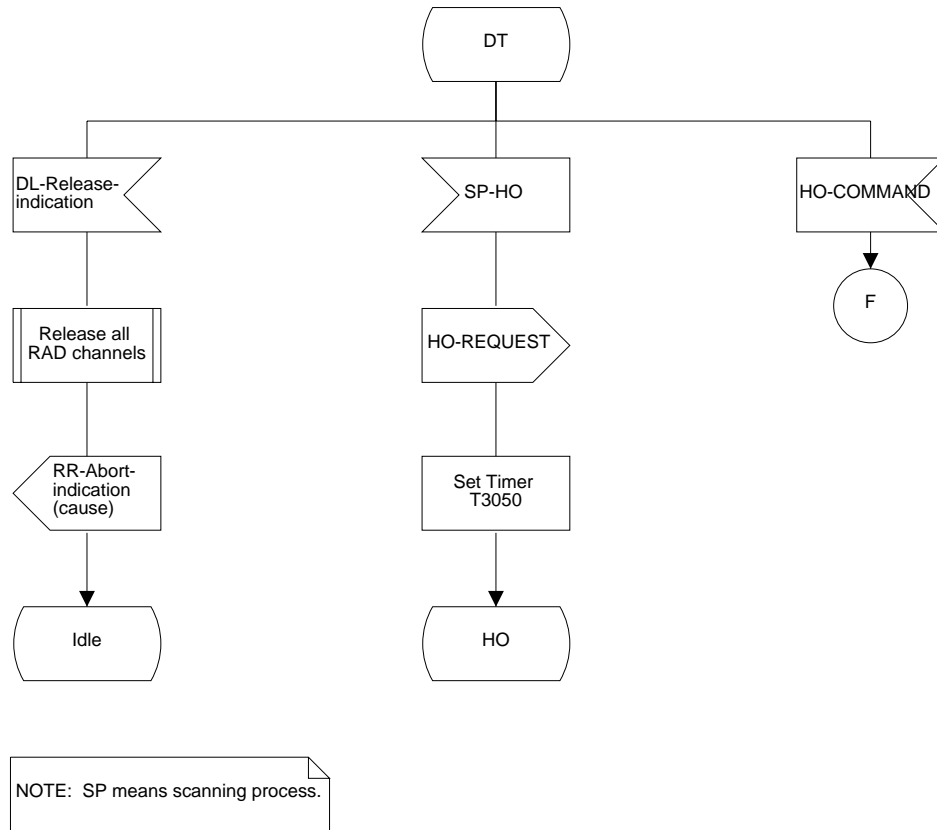
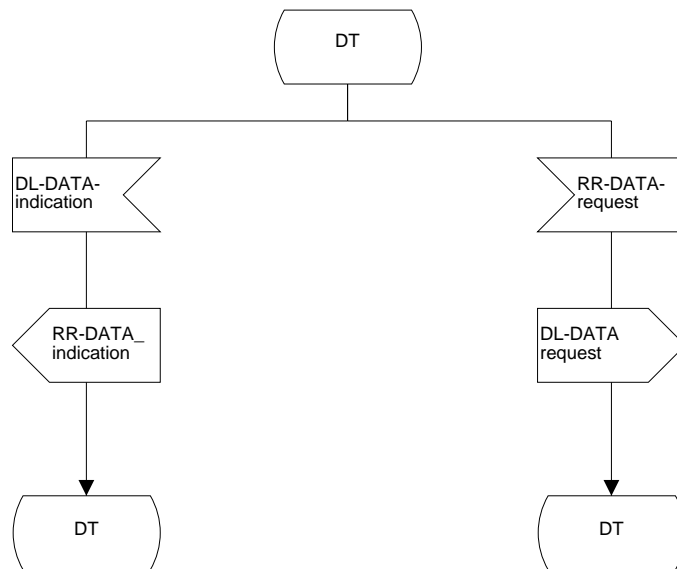


Figure 139: SDL of RR\_AT\_Protocol

Process RR\_AT\_Protocol



NOTE: DATA messages with different PD than RRM.

Figure 140: SDL of RR\_AT\_Protocol

Process RR\_AT\_Protocol

SE03262\_F141(17)

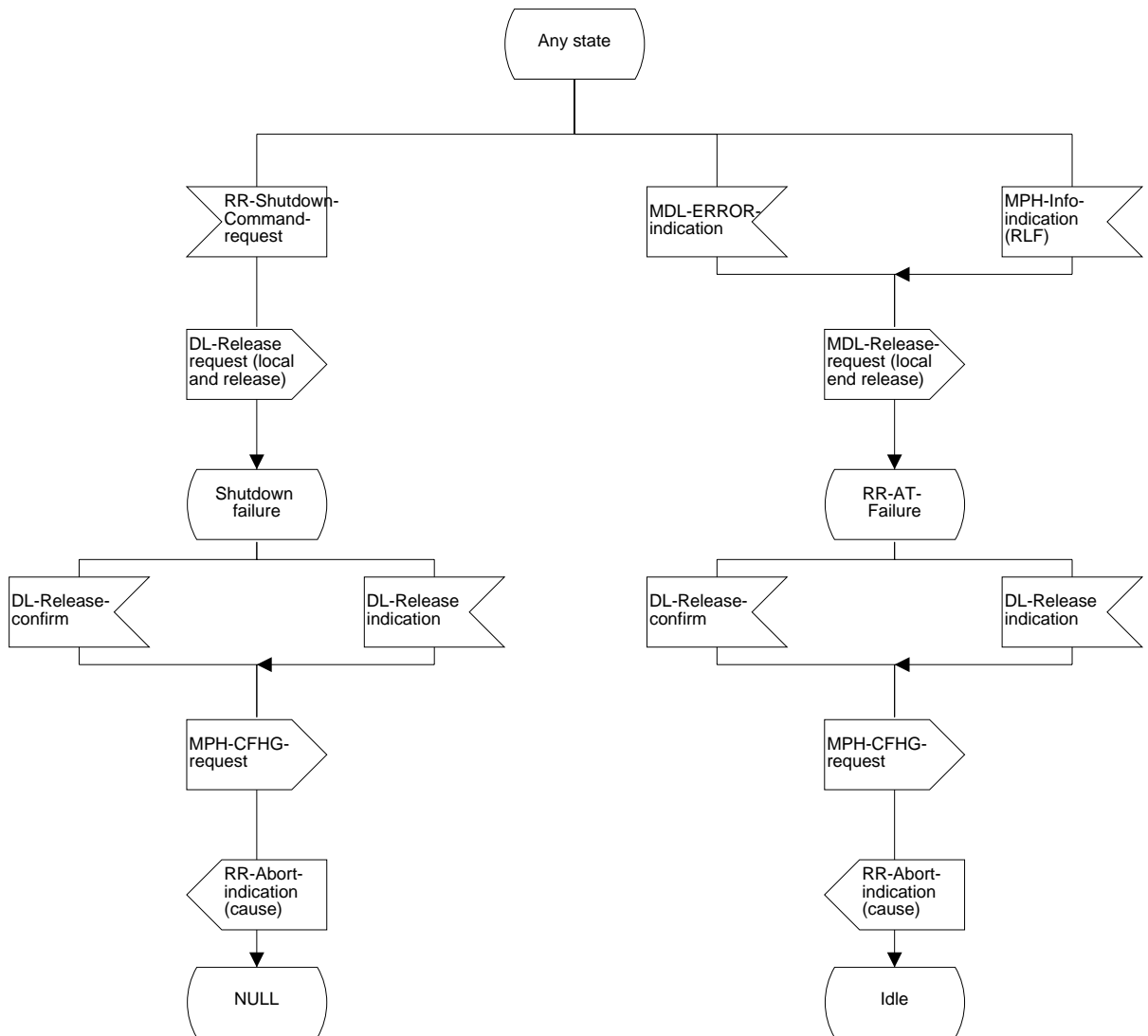


Figure 141: SDL of RR\_AT\_Protocol

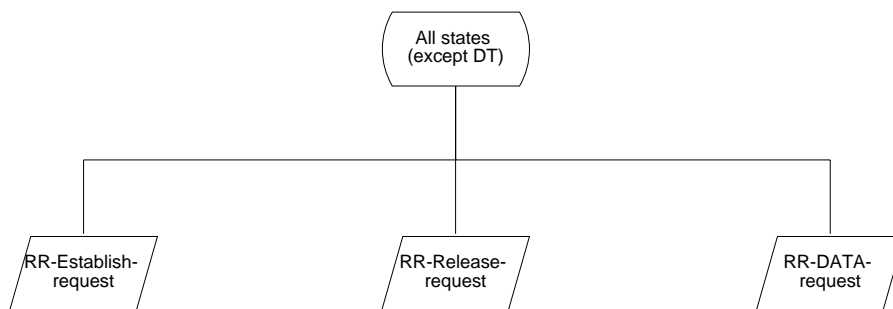


Figure 142: SDL of RR\_AT\_Protocol

Process RR\_AT\_Protocol

SE03262\_F143(17)

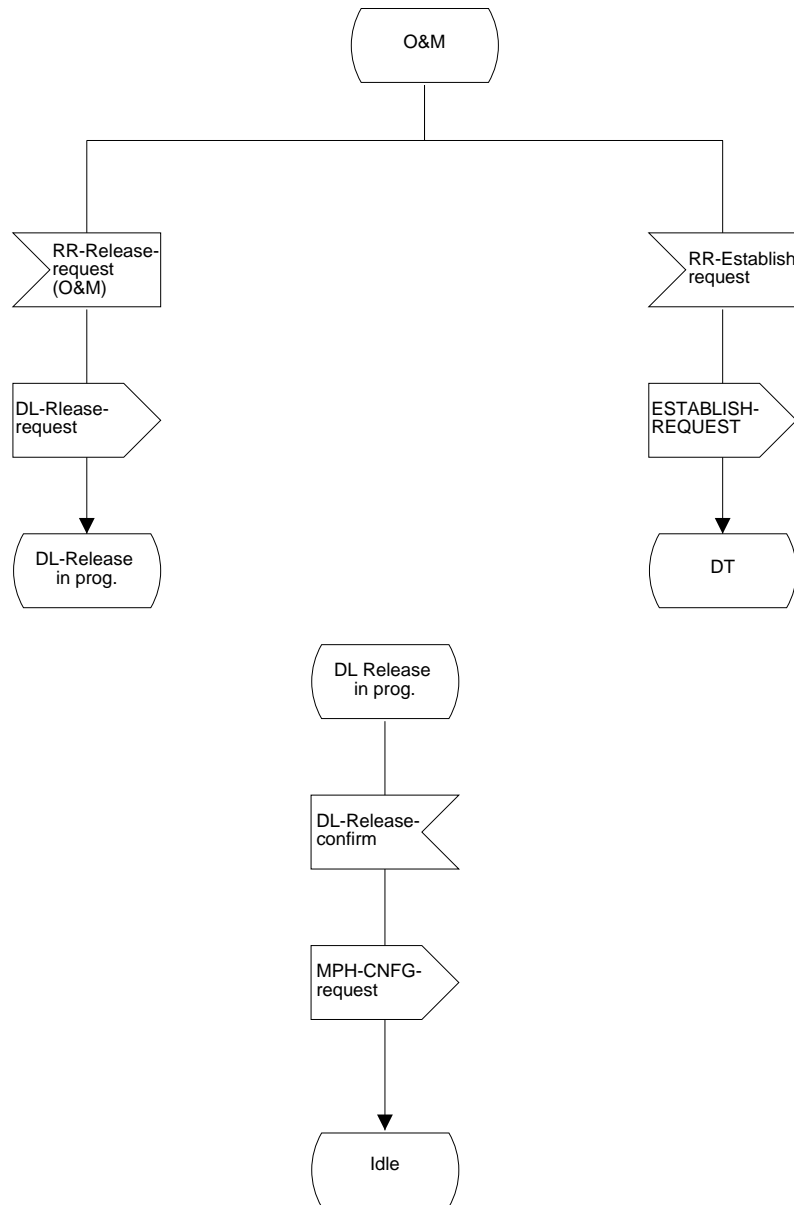


Figure 143: SDL of RR\_AT\_Protocol

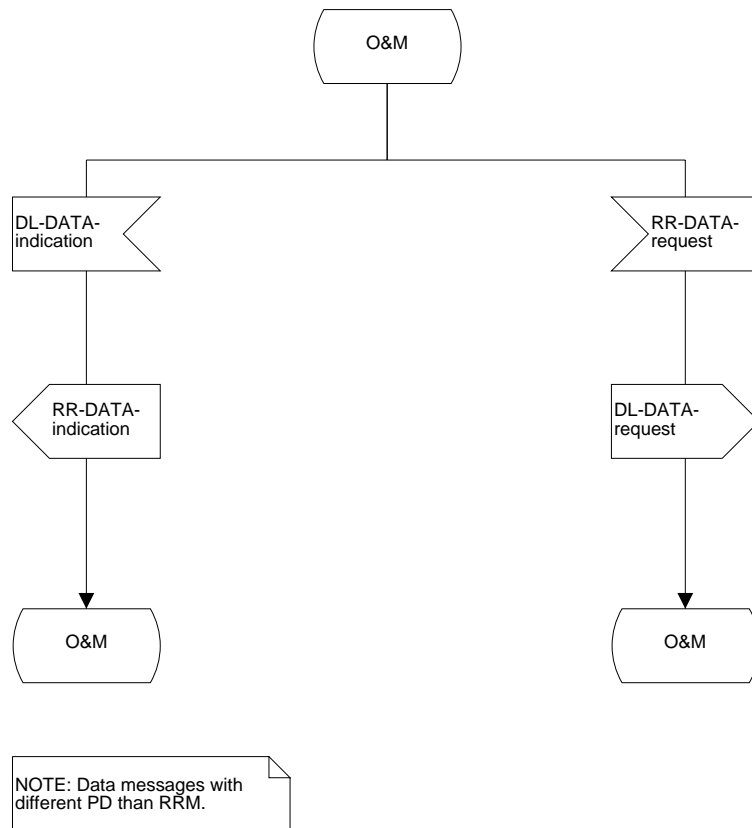


Figure 144: SDL of RR\_AT\_Protocol

Process RR\_AT\_Protocol

SE03262\_F145(17)

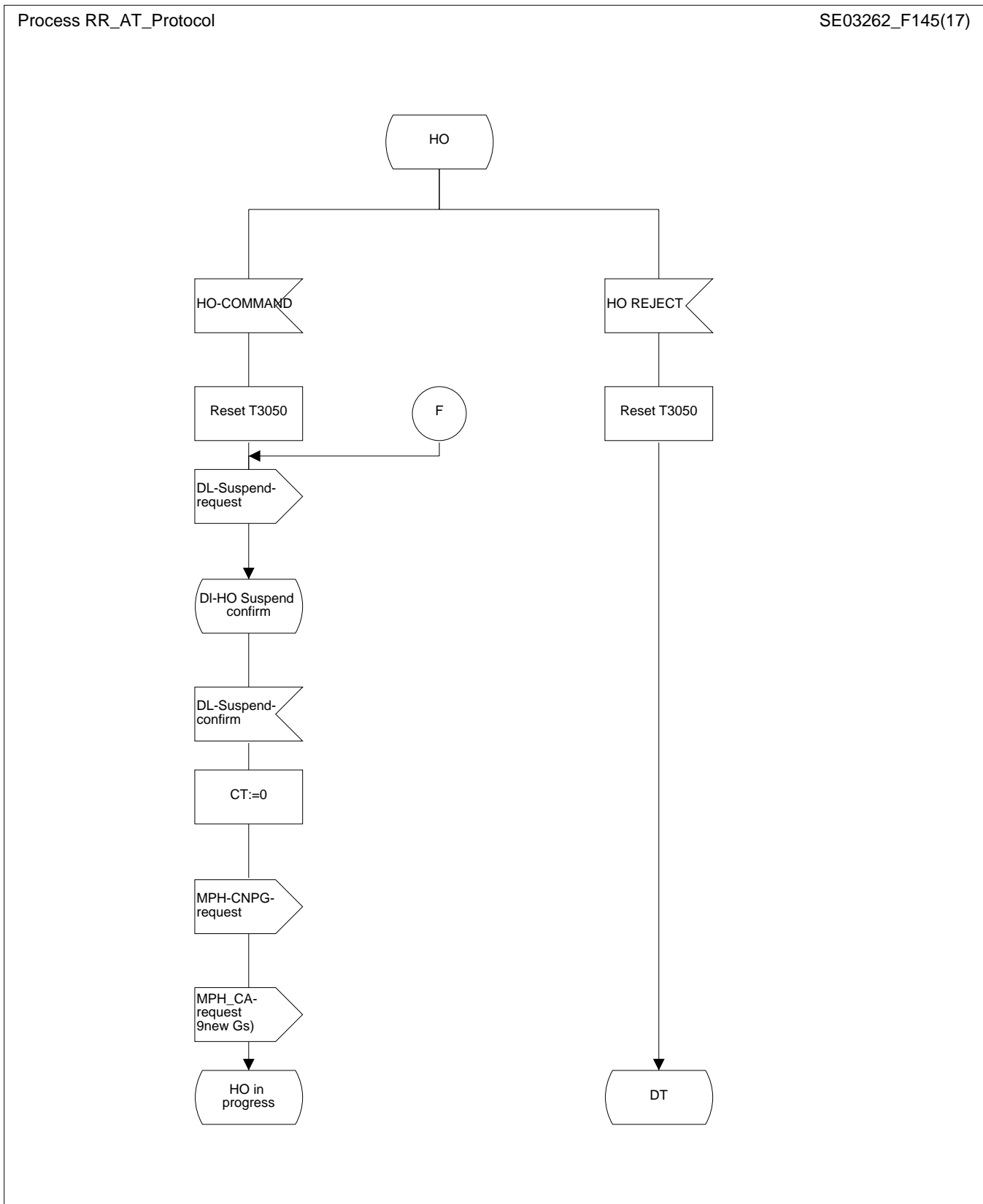


Figure 145: SDL of RR\_AT\_Protocol

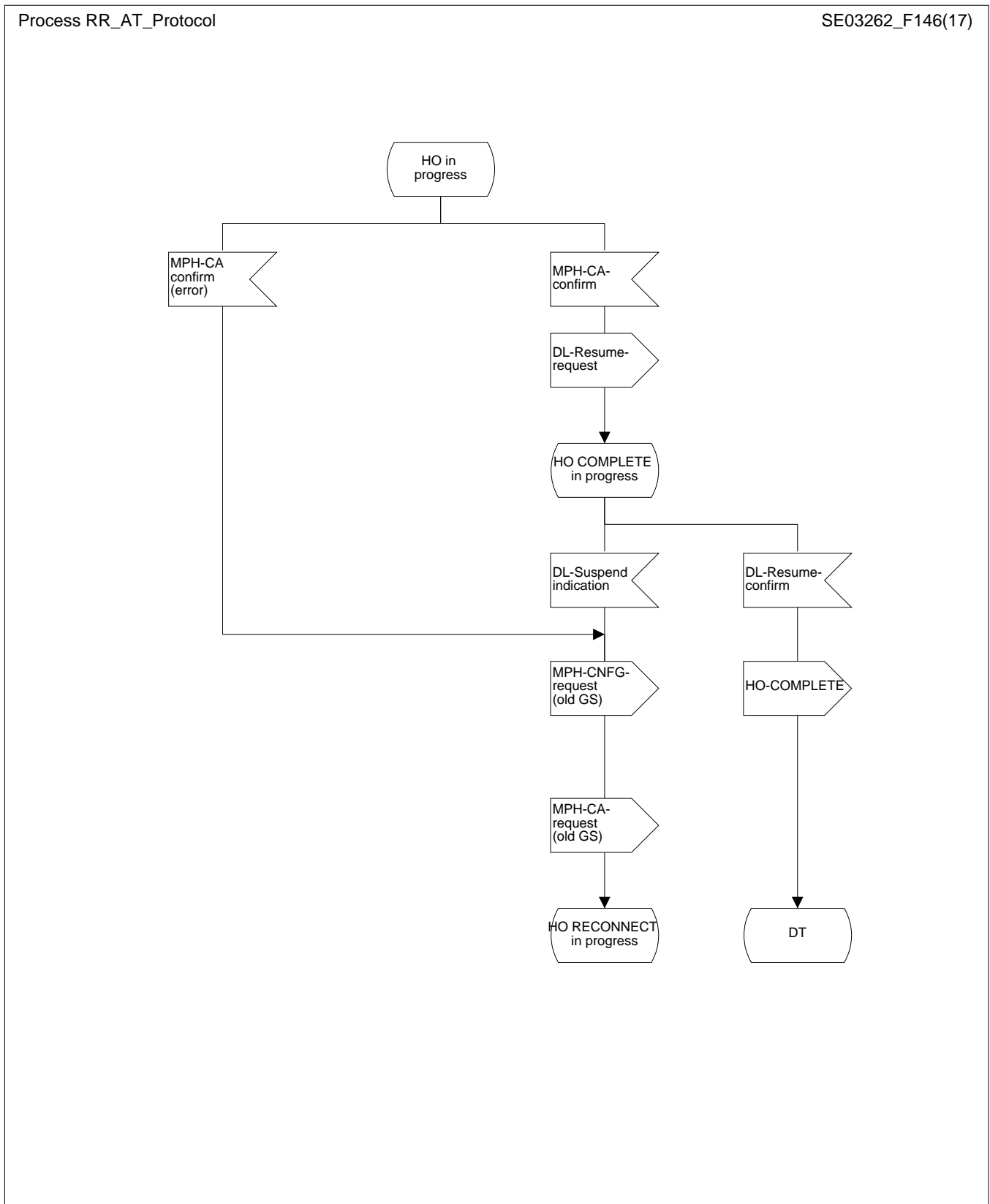


Figure 146: SDL of RR\_AT\_Protocol



Process RR\_AT\_Protocol

SE03262\_F147(17)

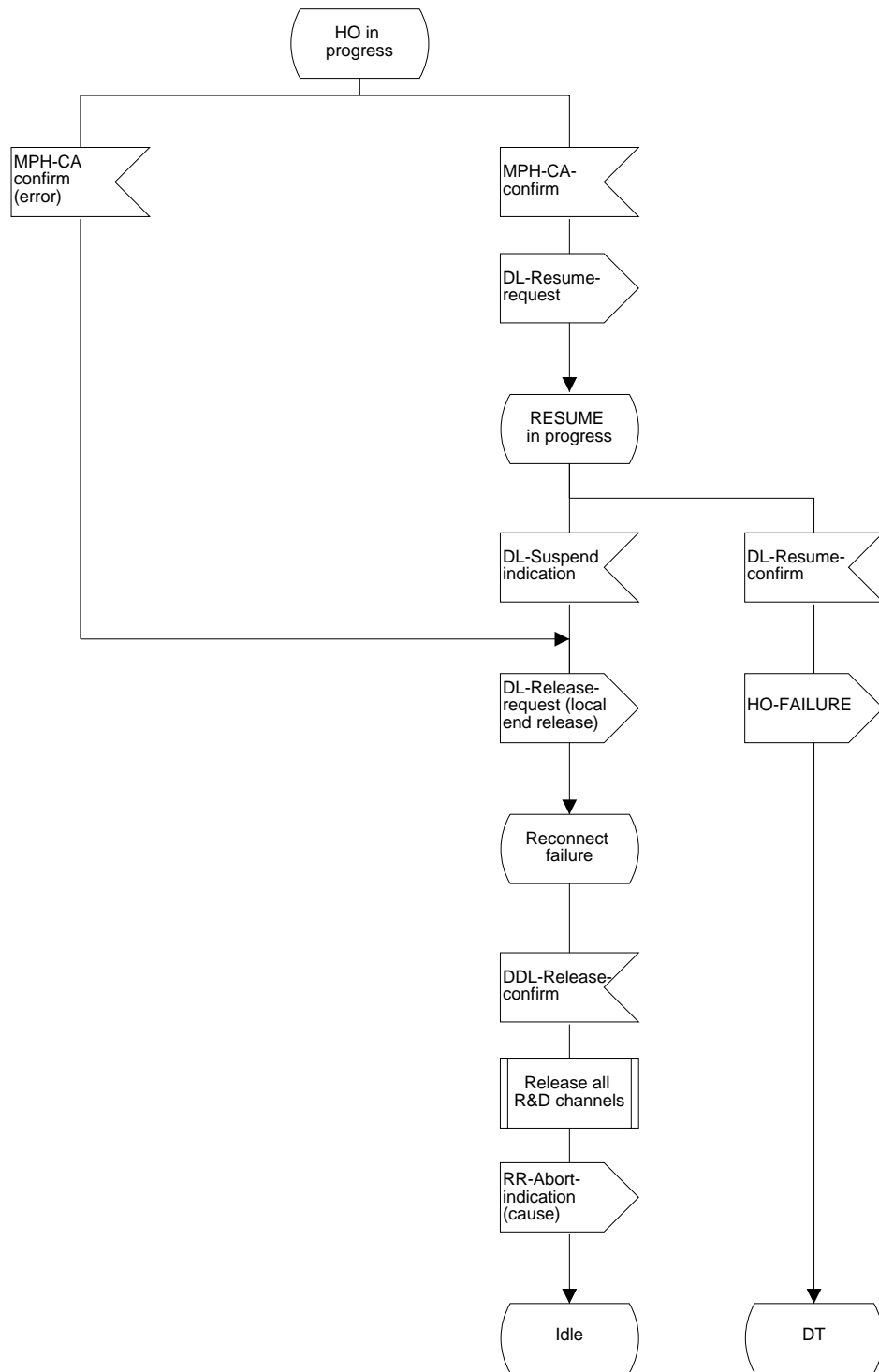


Figure 147: SDL of RR\_AT\_Protocol

Process RR\_AT\_Protocol

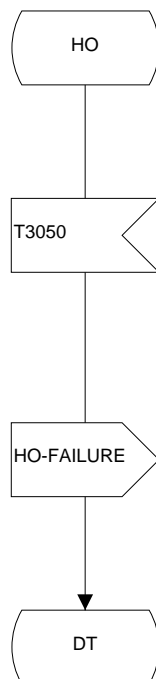


Figure 148: SDL of RR\_AT\_Protocol

Process RR\_AT\_Protocol

SE03262\_F149(17)

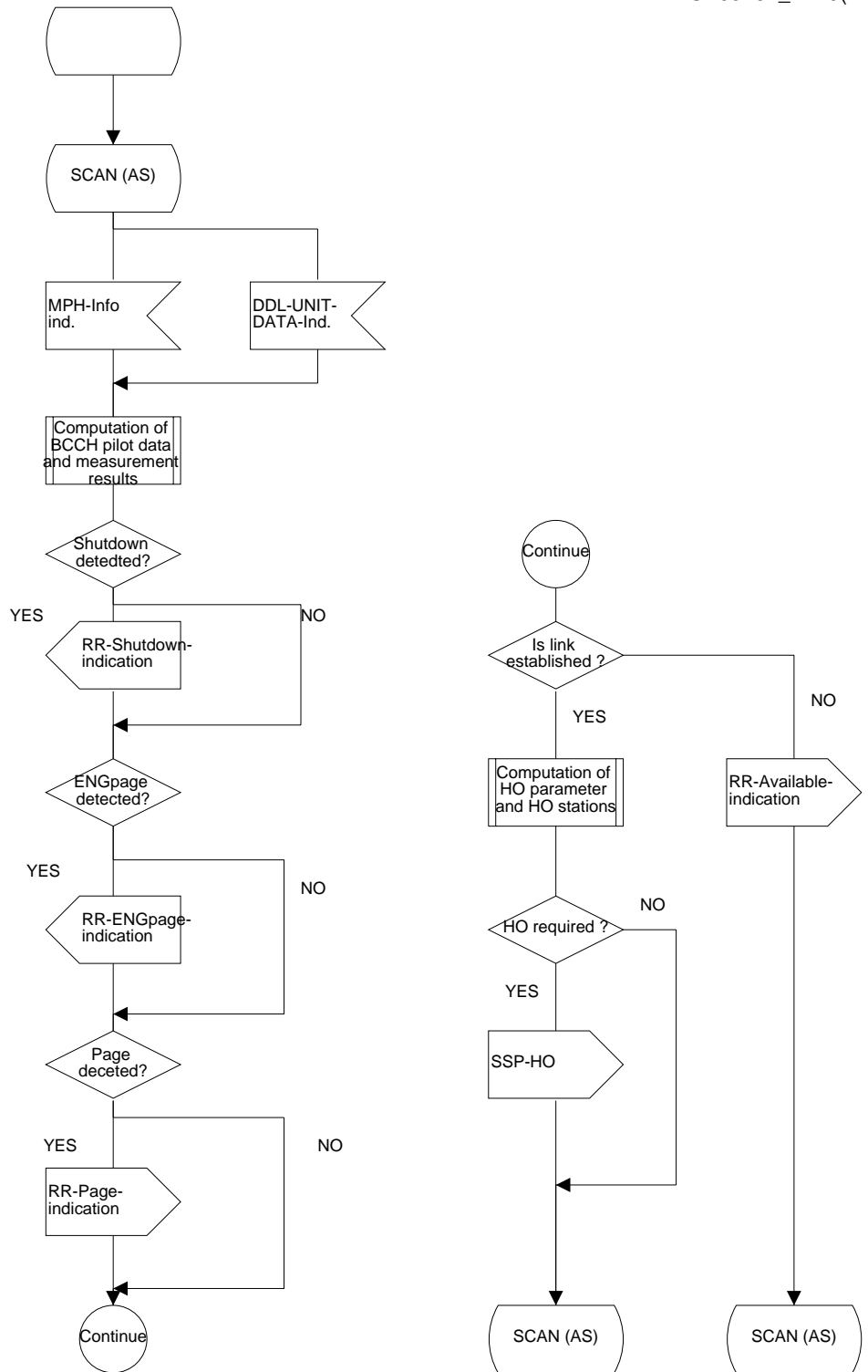


Figure 149: SDL of RR\_AT\_Protocol

Process RR\_AT\_Protocol

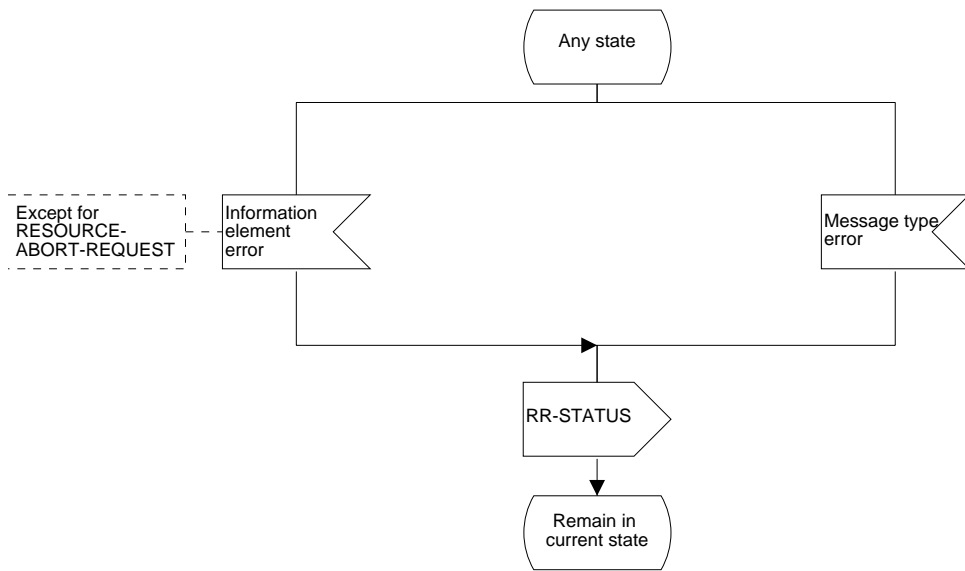


Figure 150: SDL of RR\_AT\_Protocol

Process RR\_GS\_Protocol

SE03262\_F151(14)

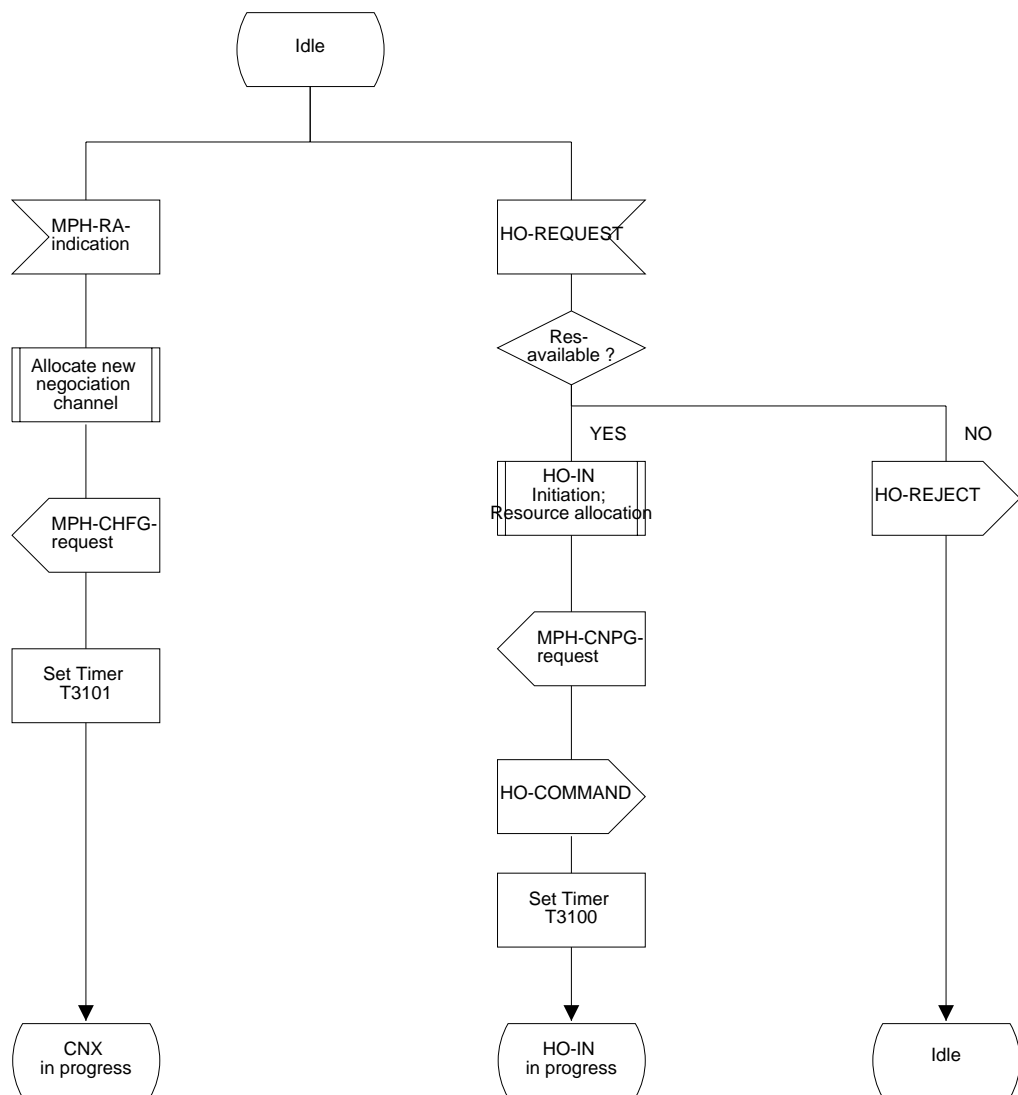


Figure 151: SDL of RR\_GS\_Protocol

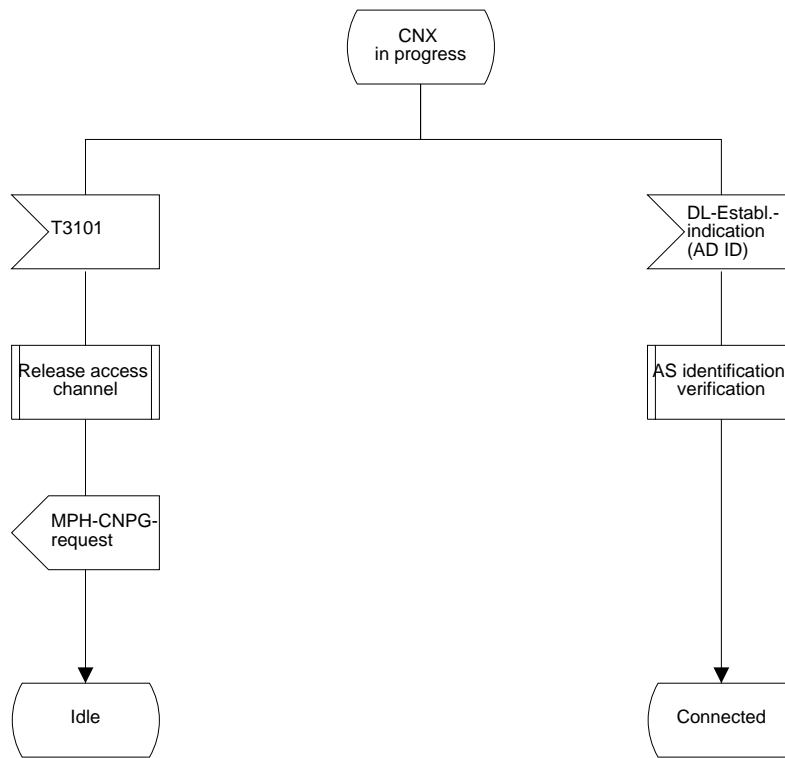


Figure 152: SDL of RR\_GS\_Protocol

Process RR\_GS\_Protocol

SE03262\_F153(14)

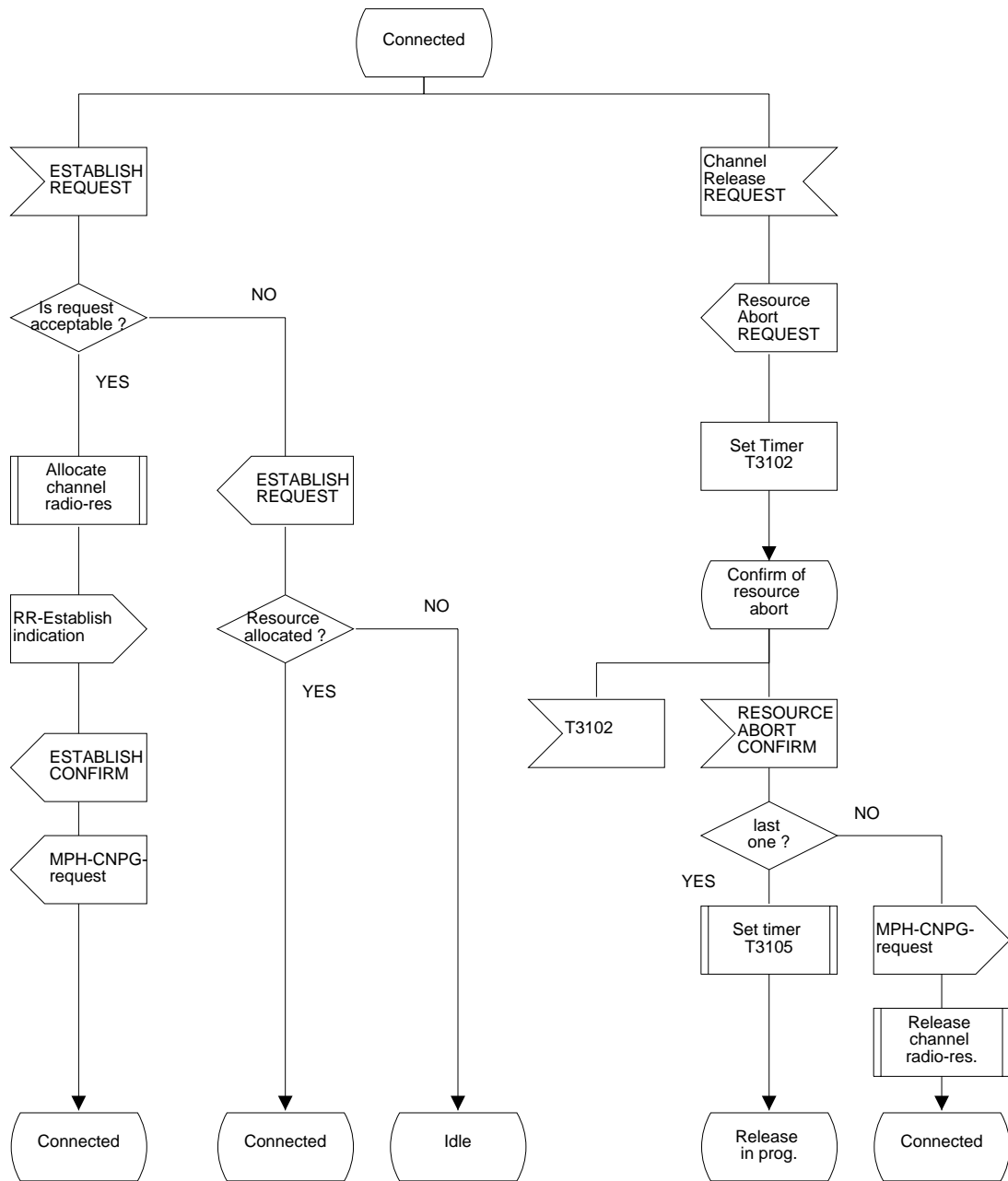


Figure 153: SDL of RR\_GS\_Protocol

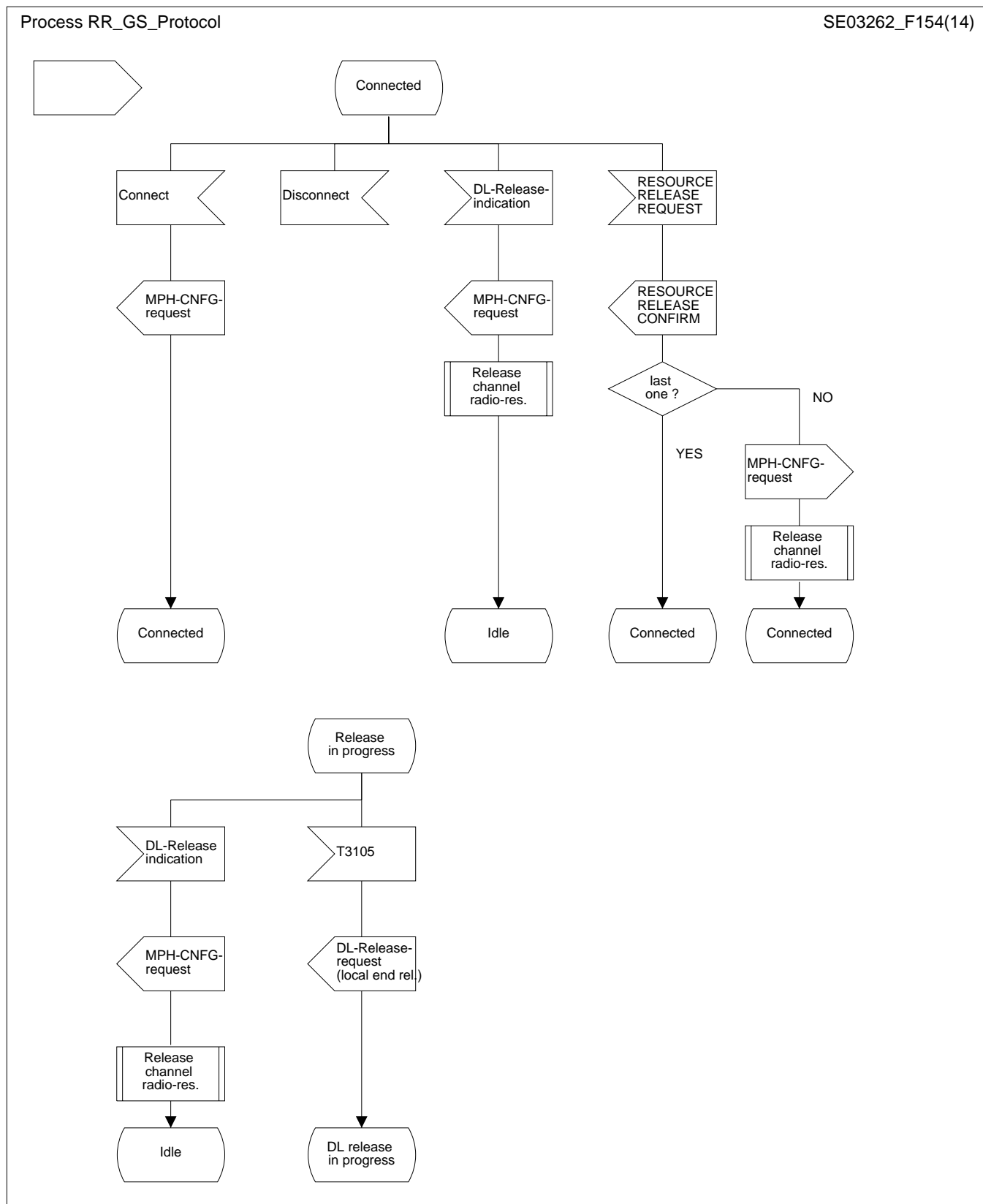


Figure 154: SDL of RR\_GS\_Protocol



Process RR\_GS\_Protocol

SE03262\_F155(14)

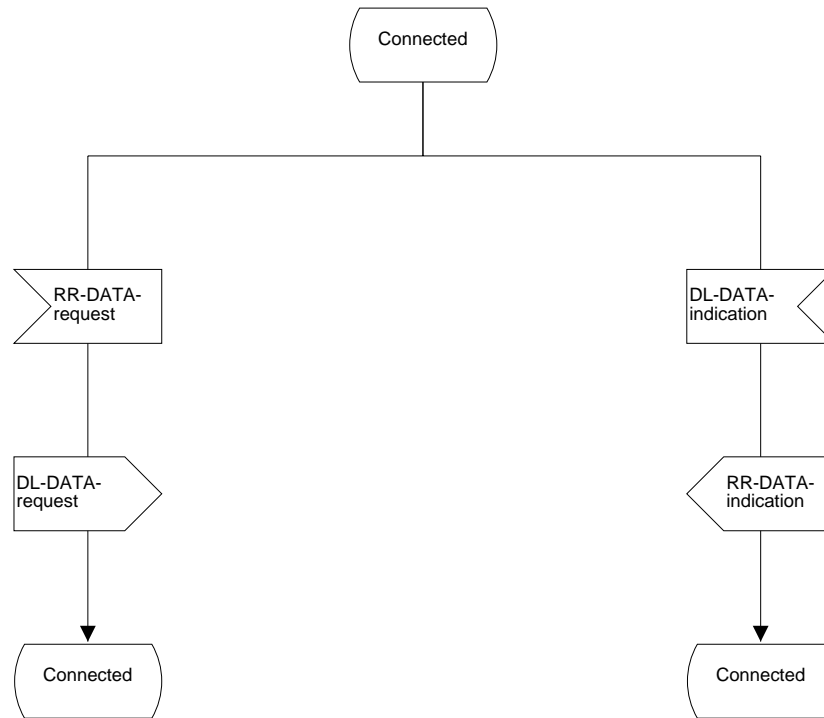


Figure 155: SDL of RR\_GS\_Protocol

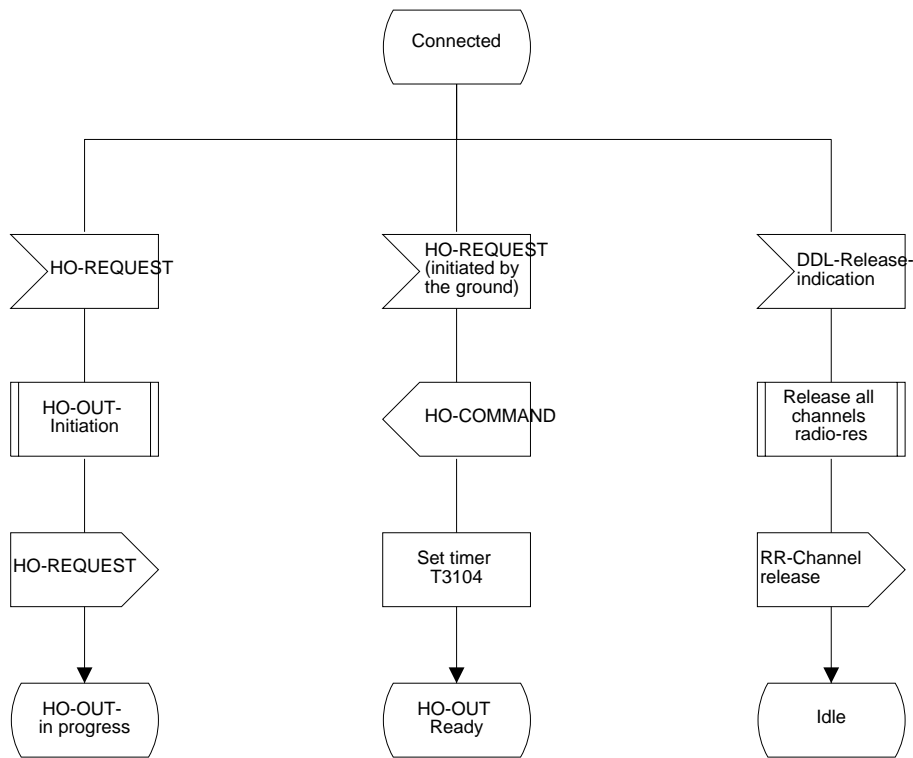


Figure 156: SDL of RR\_GS\_Protocol

Process RR\_GS\_Protocol

SE03262\_F157(14)

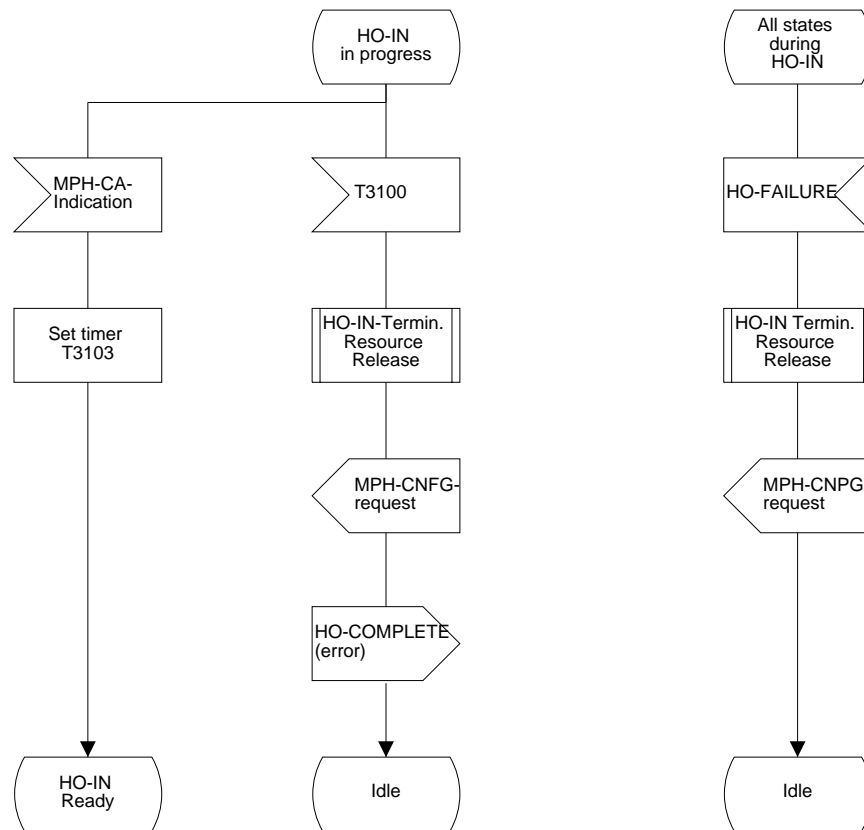


Figure 157: SDL of RR\_GS\_Protocol

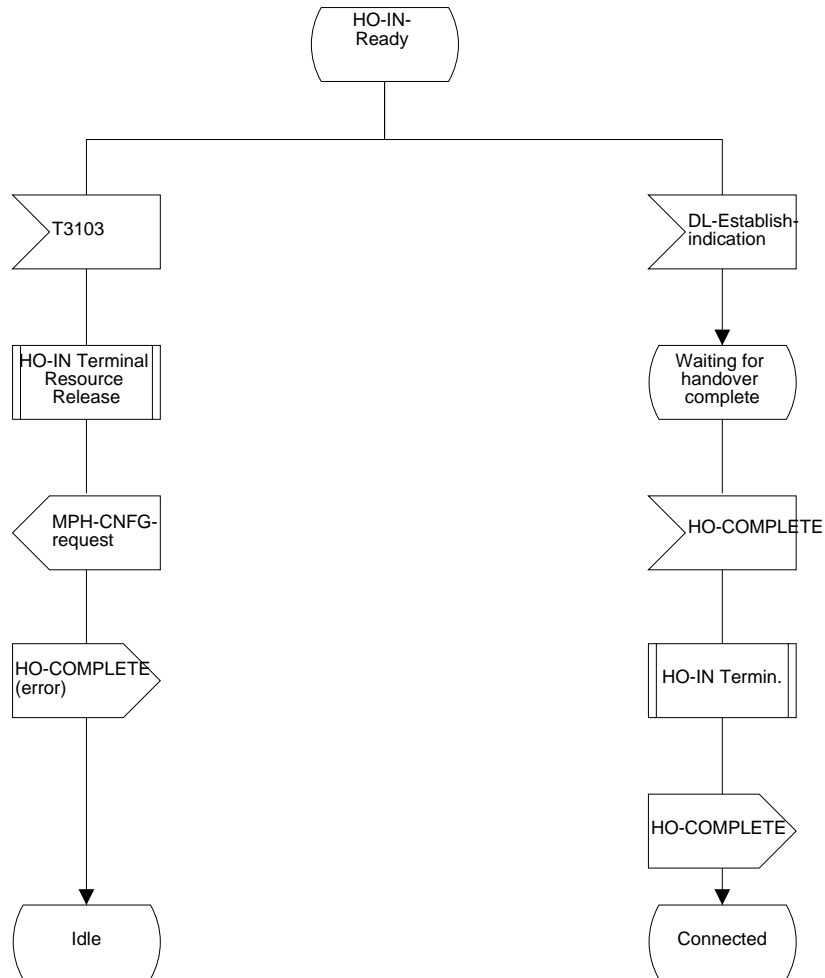


Figure 158: SDL of RR\_GS\_Protocol

Process RR\_GS\_Protocol

SE03262\_F159(14)

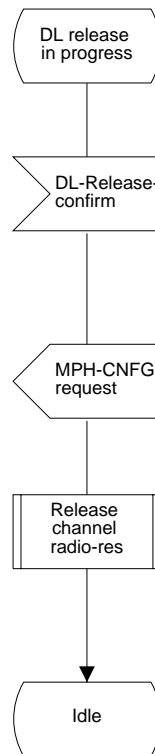


Figure 159: SDL of RR\_GS\_Protocol

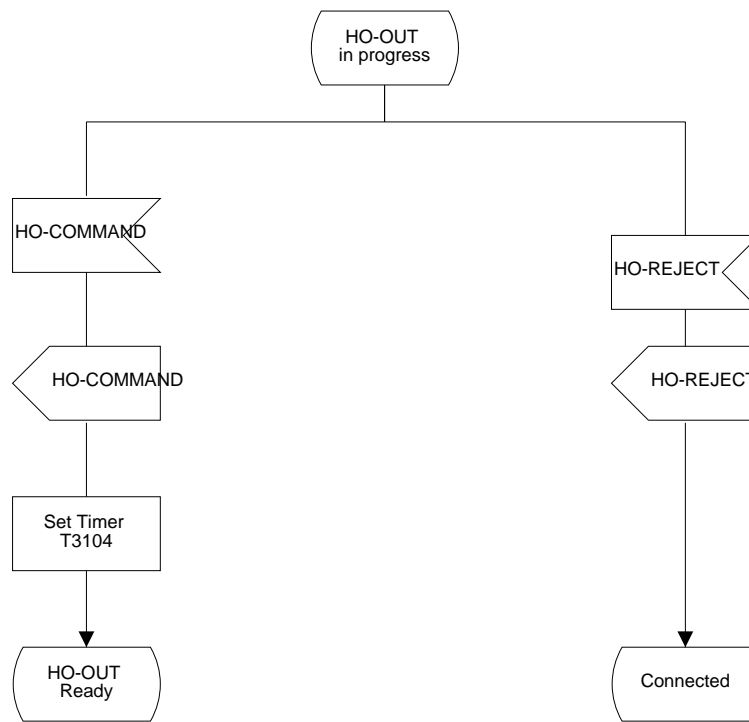


Figure 160: SDL of RR\_GS\_Protocol

Process RR\_GS\_Protocol

SE03262\_F161(14)

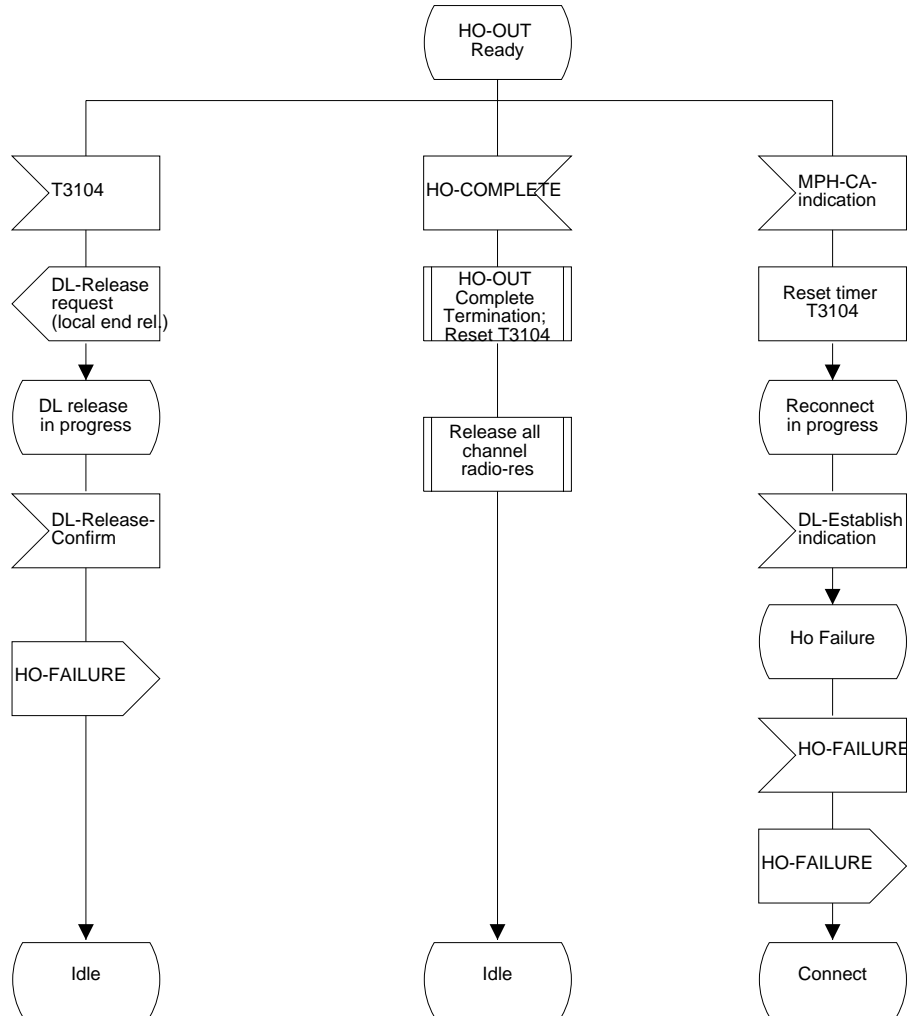


Figure 161: SDL of RR\_GS\_Protocol

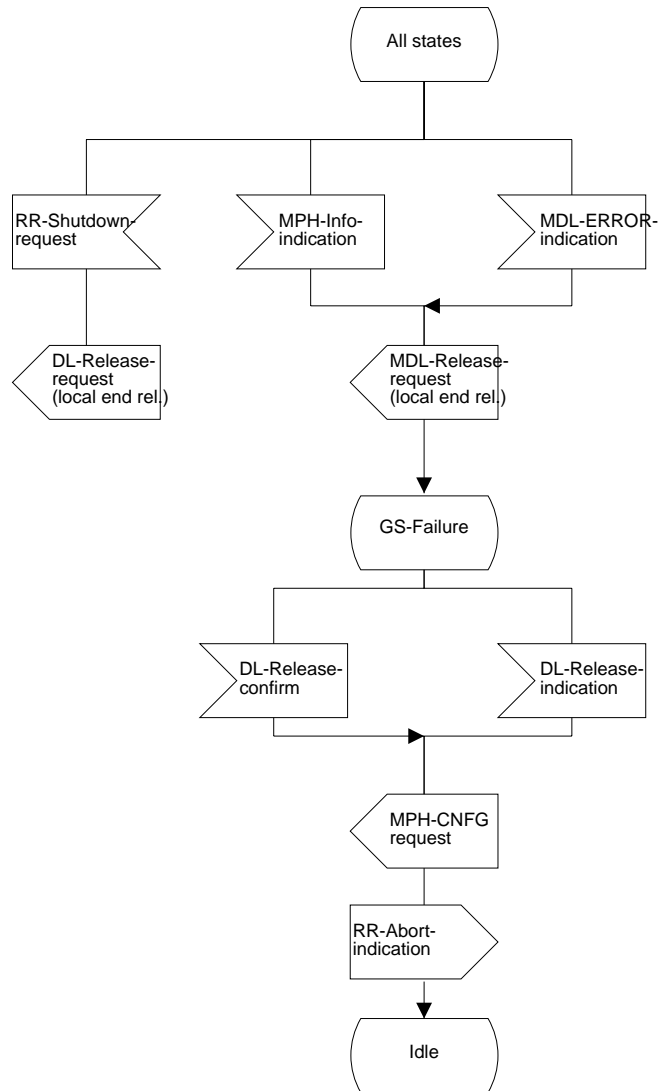


Figure 162: SDL of RR\_GS\_Protocol



Process RR\_GS\_Protocol

SE03262\_F163(14)

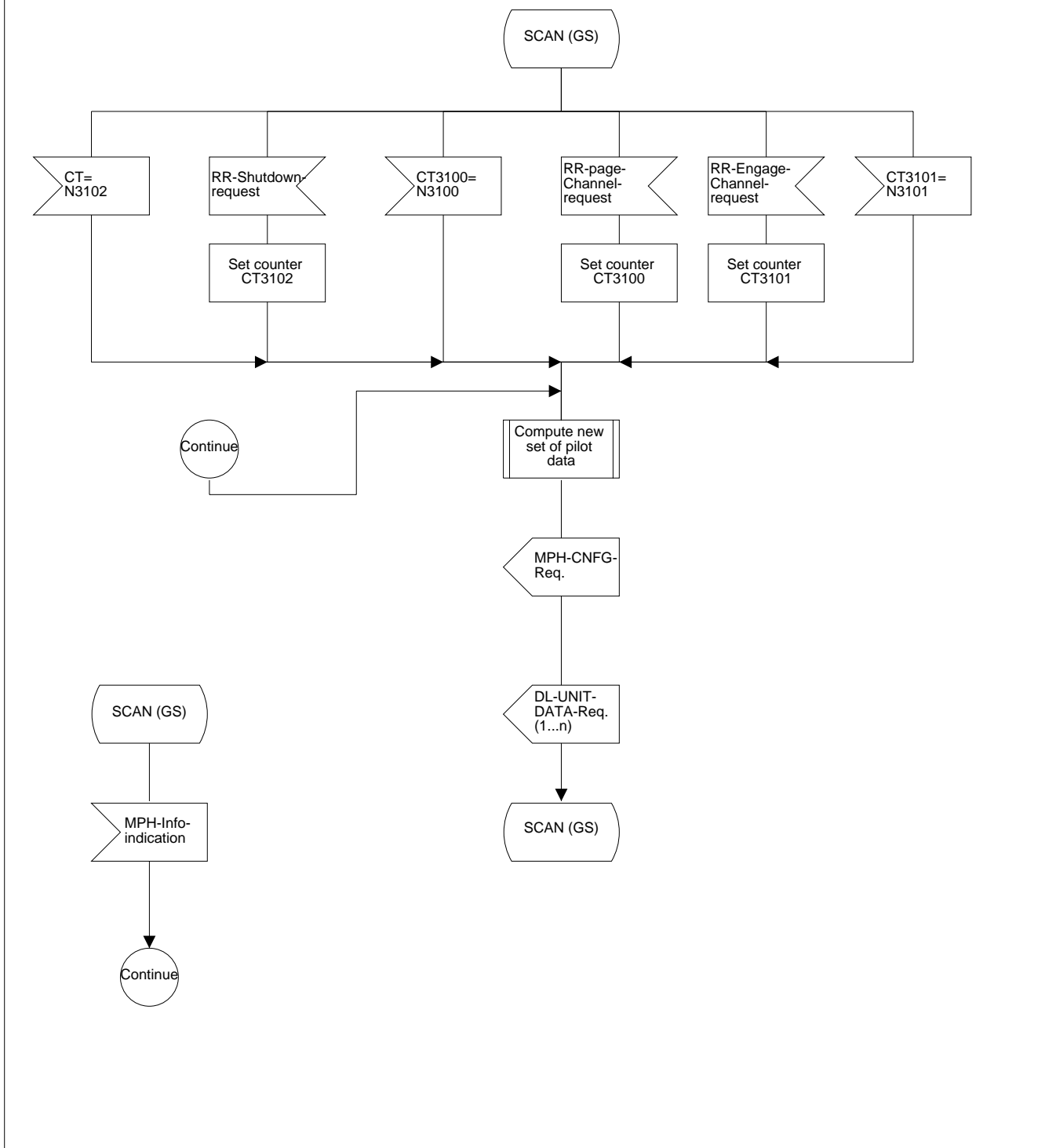


Figure 163: SDL of RR\_GS\_Protocol

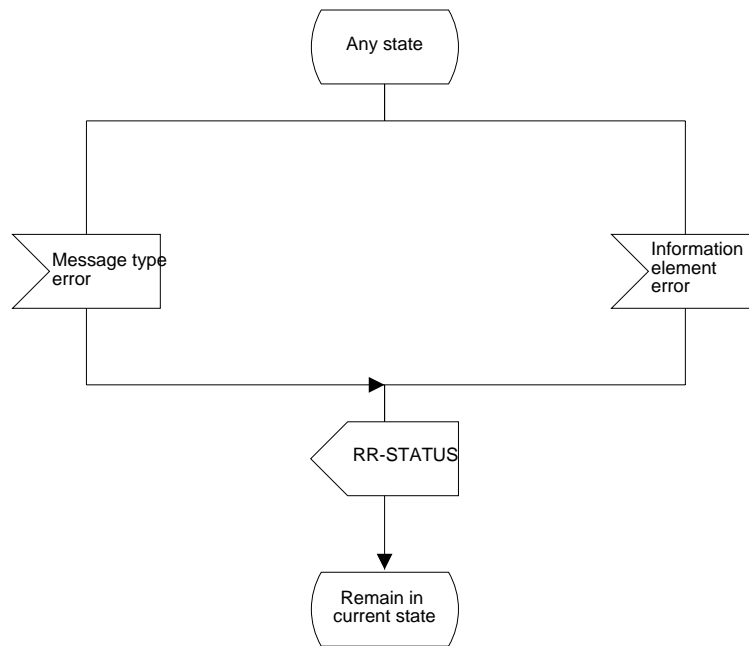


Figure 164: SDL of RR\_GS\_Protocol

## History

Document history	
July 1993	Public Enquiry PE 45: 1993-07-26 to 1993-12-17
March 1993	Vote V 76: 1995-03-20 to 1995-05-12
January 1996	First Edition
January 1996	Converted into Adobe Acrobat Portable Document Format (PDF)