



EUROPEAN
TELECOMMUNICATION
STANDARD

ETS 300 324-3

April 1999

Second Edition

Source: SPS

Reference: RE/SPS-09055-3

ICS: 33.020

Key words: V interface, V5 interface, PSTN, ISDN, AN, TSS&TP, testing, layer 3, LE

**V interfaces at the digital Local Exchange (LE);
V5.1 interface for the support of Access Network (AN);
Part 3: Test Suite Structure and Test Purposes (TSS&TP)
specification for the network layer (AN side)**

ETSI

European Telecommunications Standards Institute

ETSI Secretariat

Postal address: F-06921 Sophia Antipolis CEDEX - FRANCE

Office address: 650 Route des Lucioles - Sophia Antipolis - Valbonne - FRANCE

Internet: secretariat@etsi.fr - <http://www.etsi.org>

Tel.: +33 4 92 94 42 00 - Fax: +33 4 93 65 47 16

Copyright Notification: No part may be reproduced except as authorized by written permission. The copyright and the foregoing restriction extend to reproduction in all media.

© European Telecommunications Standards Institute 1999. All rights reserved.

Contents

Foreword	7
1 Scope	9
2 References	9
3 Definitions and abbreviations	10
3.1 Definitions	10
3.2 Abbreviations	11
4 Test Suite Structure (TSS)	12
4.1 TSS overview	12
4.2 Test groups	13
4.2.1 Protocol groups	13
4.2.1.1 Control protocol	13
4.2.1.2 PSTN protocol	14
4.2.2 Main test groups	14
4.2.2.1 Basic Interconnection (IT) tests	14
4.2.2.2 Capability (CA) tests	14
4.2.2.3 Valid Behaviour (BV) tests	14
4.2.2.4 Inopportune Behaviour (BO) tests	14
4.2.2.5 Invalid Behaviour (BI) tests	14
4.2.2.6 Timer (TI) expiry and counter mismatch tests	15
4.2.2.6.1 Timer expiry and counters of the Control protocol	15
4.2.2.6.2 Timer expiry and counters of the PSTN protocol	15
4.2.2.6.3 Timer expiry and counters of the AN system management	15
4.3 Test step structure	15
4.3.1 State transitions	16
4.3.1.1 Startup of V5.1 interface	16
4.3.1.2 Common control protocol (system management)	17
4.3.1.3 Control protocol (PSTN port FSM)	17
4.3.1.4 Control protocol (ISDN-BA port FSM)	18
4.3.1.5 PSTN protocol	18
4.3.2 Preconditions	19
4.3.3 Preambles	19
4.3.4 Postambles	19
4.3.5 Status verification	19
4.3.5.1 PSTN protocol	19
4.3.5.2 Port control protocol	19
4.3.5.3 Common control protocol	19
4.3.6 Common test steps	20
4.4 Defaults	20
4.5 Abstract Service Primitives (ASPs) and Protocol Data Units (PDUs)	20
4.5.1 ASPs	20
4.5.2 PDUs	20
4.5.2.1 Common control protocol	20
4.5.2.2 Port control protocol	20
4.5.2.3 PSTN protocol	20
4.5.3 Information elements	20
4.5.3.1 Variable length information elements	20
4.5.3.1.1 Control protocol	20
4.5.3.1.2 PSTN protocol	21
4.5.3.2 Single octet information elements	21
4.5.3.2.1 Control protocol	21

	4.5.3.2.2	PSTN protocol	21
4.6		Timers and counters of the Abstract Test Suite (ATS)	22
5		Test Purposes (TPs)	23
5.1		Introduction	23
	5.1.1	TP naming convention	23
	5.1.2	Source of TP definition	24
	5.1.3	Test strategy	24
	5.1.4	Requirements not covered by TPs	24
	5.1.5	Initial state	25
	5.1.6	Test and data configuration requirements	25
5.2		Control protocol	25
	5.2.1	Basic interconnection tests (V5NWKAN/CTRL/IT)	25
	5.2.2	Capability tests (V5NWKAN/CTRL/CA)	25
	5.2.3	Valid behaviour tests (V5NWKAN/CTRL/BV)	26
	5.2.3.1	V5NWKAN/CTRL/BV/COM	26
	5.2.3.1.1	V5NWKAN/CTRL/BV/COM/TRANS	26
	5.2.3.1.2	V5NWKAN/CTRL/BV/COM/REST	26
	5.2.3.1.3	V5NWKAN/CTRL/BV/COM/REVV	27
	5.2.3.2	V5NWKAN/CTRL/BV/PORT	28
	5.2.3.2.1	V5NWKAN/CTRL/BV/PORT/TRANS	28
	5.2.3.2.2	V5NWKAN/CTRL/BV/PORT/PSTN	29
	5.2.3.2.3	V5NWKAN/CTRL/BV/PORT/ISDNBA	31
	5.2.4	Inopportune behaviour tests (V5NWKAN/CTRL/BO)	34
	5.2.4.1	V5NWKAN/CTRL/BO/COM	34
	5.2.4.1.1	V5NWKAN/CTRL/BO/COM/TRANS	34
	5.2.4.1.2	V5NWKAN/CTRL/BO/COM/REVV	34
	5.2.4.2	V5NWKAN/CTRL/BO/PORT	34
	5.2.4.2.1	V5NWKAN/CTRL/BO/PORT/TRANS	34
	5.2.4.2.2	V5NWKAN/CTRL/BO/PORT/PSTN	34
	5.2.4.2.3	V5NWKAN/CTRL/BO/PORT/ISDNBA	35
	5.2.5	Invalid behaviour tests (V5NWKAN/CTRL/BI)	35
	5.2.5.1	V5NWKAN/CTRL/BI/COM	35
	5.2.5.1.1	V5NWKAN/CTRL/BI/COM/TRANS	35
	5.2.5.2	V5NWKAN/CTRL/BI/PORT	36
	5.2.5.2.1	V5NWKAN/CTRL/BI/PORT/TRANS	36
	5.2.6	Timer expiry and counter mismatch tests (V5NWKAN/CTRL/TI)	37
	5.2.6.1	V5NWKAN/CTRL/TI/COM	37
	5.2.6.1.1	V5NWKAN/CTRL/TI/COM/TRANS	37
	5.2.6.2	V5NWKAN/CTRL/TI/PORT	38
	5.2.6.2.1	V5NWKAN/CTRL/TI/PORT/TRANS	38
5.3		PSTN protocol	38
	5.3.1	Basic interconnection tests (V5NWKAN/PSTN/IT)	38
	5.3.2	Capability tests (V5NWKAN/PSTN/CA)	39
	5.3.3	Valid behaviour tests (V5NWKAN/PSTN/BV)	39
	5.3.3.1	V5NWKAN/PSTN/BV/0	39
	5.3.3.2	V5NWKAN/PSTN/BV/1	40
	5.3.3.3	V5NWKAN/PSTN/BV/2	41
	5.3.3.4	V5NWKAN/PSTN/BV/3	42
	5.3.3.5	V5NWKAN/PSTN/BV/4	43
	5.3.3.6	V5NWKAN/PSTN/BV/5	44
	5.3.3.7	V5NWKAN/PSTN/BV/6	45
	5.3.3.8	V5NWKAN/PSTN/BV/7	45
	5.3.4	Inopportune behaviour tests (V5NWKAN/PSTN/BO)	47
	5.3.4.1	V5NWKAN/PSTN/BO/0	47
	5.3.4.2	V5NWKAN/PSTN/BO/1	47
	5.3.4.3	V5NWKAN/PSTN/BO/2	48
	5.3.4.4	V5NWKAN/PSTN/BO/3	48
	5.3.4.5	V5NWKAN/PSTN/BO/4	49
	5.3.4.6	V5NWKAN/PSTN/BO/5	49
	5.3.4.7	V5NWKAN/PSTN/BO/6	50
	5.3.4.8	V5NWKAN/PSTN/BO/7	51
	5.3.5	Invalid behaviour tests (V5NWKAN/PSTN/BI)	51

- 5.3.5.1 V5NWKAN/PSTN/BI/1 51
- 5.3.5.2 V5NWKAN/PSTN/BI/5 52
- 5.3.6 Timer expiry and counter mismatch tests (V5NWKAN/PSTN/TI)..... 53
 - 5.3.6.1 V5NWKAN/PSTN/TI/2 53
 - 5.3.6.2 V5NWKAN/PSTN/TI/3 53
 - 5.3.6.3 V5NWKAN/PSTN/TI/4 53
 - 5.3.6.4 V5NWKAN/PSTN/TI/5 54
 - 5.3.6.5 V5NWKAN/PSTN/TI/7 54

- Annex A (informative): Bibliography..... 55

- History 56

Blank page

Foreword

This European Telecommunication Standard (ETS) has been produced by the Signalling Protocols and Switching (SPS) Technical Committee of the European Telecommunications Standards Institute (ETSI).

This ETS is part 3 of a multi-part standard covering the V5.1 interface as described below:

- Part 1: "V5.1 interface specification";
- Part 2: "Protocol Implementation Conformance Statement (PICS) proforma";
- Part 3: "Test Suite Structure and Test Purposes (TSS&TP) specification for the network layer (AN side)";**
- Part 4: "Abstract Test Suite (ATS) and partial Protocol Implementation eXtra Information for Testing (PIXIT) proforma specification for the network layer (AN side)";
- Part 5: "Test Suite Structure and Test Purposes (TSS&TP) specification for the network layer (LE side)";
- Part 6: "Abstract Test Suite (ATS) and partial Protocol Implementation eXtra Information for Testing (PIXIT) proforma specification for the network layer (LE side)";
- Part 7: "Test Suite Structure and Test Purposes (TSS&TP) specification for the data link layer";
- Part 8: "Abstract Test Suite (ATS) and partial Protocol Implementation eXtra Information for Testing (PIXIT) proforma specification for the data link layer";
- Part 9: "Test specification for the physical layer".

Transposition dates	
Date of adoption of this ETS:	26 March 1999
Date of latest announcement of this ETS (doa):	30 June 1999
Date of latest publication of new National Standard or endorsement of this ETS (dop/e):	31 December 1999
Date of withdrawal of any conflicting National Standard (dow):	31 December 1999

Blank page

1 Scope

This third part of ETS 300 324 contains the Test Suite Structure (TSS) and Test Purposes (TPs) for the Network layer (NWK) and parts of the system management of the Access Network (AN) side of a V5.1 interface.

The objective of this ETS is to provide conformance tests giving a high probability of inter-operability of an AN and a Local Exchange (LE) from different manufacturers over the V5.1 interface. This ETS covers only the procedures described in ETS 300 324-1 [1].

ISO/IEC 9646-1 [5] is used as the basis for the methodology of conformance testing.

Concerning the Public Switched Telephone Network (PSTN) protocol testing, only the procedures defined in ETS 300 324-1 [1] are covered by the tests defined in this ETS. An Implementation Under Test (IUT), however, will have implemented a national PSTN protocol part as well. This requires that the tester generates messages containing the national PSTN protocol specific optional Information Elements (IEs), otherwise the IUT would not act on messages according to the PSTN protocol procedure definition. However, this does not provide a comprehensive test of the national PSTN protocol mapping specification, which is outside the scope of this ETS.

As the tests use PSTN messages containing optional IEs according to national specifications, the test result is only valid for the implemented national mapping of the V5.1 PSTN protocol.

This ETS does not cover tests related to functions of the bearer channel. Those functions should be tested in conjunction with testing of the national PSTN protocol mapping specification.

This ETS contains no requirements concerning NWK tests for Integrated Services Digital Network Basic Access (ISDN-BA).

2 References

This ETS incorporates by dated and undated reference, provisions from other publications. These references are cited at the appropriate places in the text and the publications are listed hereafter. For dated references, subsequent amendments to or revisions of any of these publications apply to this ETS only when incorporated in it by amendment or revision. For undated references the latest edition of the publication referred to applies.

- [1] ETS 300 324-1 (1994) including amendment A1: "V interfaces at the digital Local Exchange (LE); V5.1 interface for the support of Access Network (AN); Part 1: V5.1 interface specification".
- [2] ETS 300 324-2 (1994): "V interfaces at the digital Local Exchange (LE); V5.1 interface for the support of Access Network (AN); Part 2: Protocol Implementation Conformance Statement (PICS) proforma".
- [3] ETS 300 297 (1995): "Integrated Services Digital Network (ISDN); Access Digital Section for ISDN basic rate".
- [4] ISO 7498: "Information Processing Systems - Open Systems Interconnection - Basic Reference Model".
- [5] ISO/IEC 9646-1: "Information technology - Open Systems Interconnection - Conformance testing methodology and framework - Part 1: General concepts".

3 Definitions and abbreviations

3.1 Definitions

For the purposes of this ETS, the following definitions apply, together with those given in ETS 300 324-1 [1]:

Abstract Test Case (ATC): Refer to ISO/IEC 9646-1 [5]

Abstract Test Suite (ATS): Refer to ISO/IEC 9646-1 [5]

current provisioning variant: Identifier for the presently active data set

data link layer: Refer to ISO 7498 [4]

implementation under test: Refer to ISO/IEC 9646-1 [5]

incorrect information element: Specified information element carrying information element types not defined in ETS 300 324-1 [1]

invalid PSTN information element: PSTN information element not according to national specific requirements

invalid Protocol Data Unit: PDU which contains incorrect message format

invalid PSTN message: PSTN message carrying information elements not according to national specific requirements

lower tester: Refer to ISO/IEC 9646-1 [5]

network layer: Refer to ISO 7498 [4]

network termination: Equipment providing the network side at the ISDN user-network interface for the basic access

NOTE: This term is used in this ETS to indicate network-terminating aspects of NT1 and NT2.

new provisioning variant: Identifier for the data set which was announced to the IUT to become the next active data set through reprovisioning

physical layer: Refer to ISO 7498 [4]

Protocol Implementation Conformance Statement: Refer to ISO/IEC 9646-1 [5]

PICS proforma: Refer to ISO/IEC 9646-1 [5]

specified information element: Information element identifier defined in ETS 300 324-1 [1]

System Under Test (SUT): Refer to ISO/IEC 9646-1 [5]

Test Purpose (TP): Refer to ISO/IEC 9646-1 [5]

unknown provisioning variant: Identifier for a non-available data set

unspecified Information Element: Information element identifier not defined in ETS 300 324-1 [1]

valid information element: PSTN information element according to national specific requirements

valid PSTN message: PSTN message carrying information elements according to national specific requirements

3.2 Abbreviations

For the purposes of this ETS, the following abbreviations apply:

AN	Access Network
ASP	Abstract Service Primitive
ATC	Abstract Test Case
ATS	Abstract Test Suite
BI	Invalid Behaviour
BO	Inopportune Behaviour
BV	Valid Behaviour
CA	Capability
COM	Common control protocol
CTRL	Control
DSAP	Data link Service Access Point
FE	Function Element
FSM	Finite State Machine
ID	Identifier
IE	Information Element
ISDN	Integrated Services Digital Network
ISDN-BA	ISDN Basic Access
IT	Basic Interconnection
IUT	Implementation Under Test
L3addr	Layer 3 address
LE	Local Exchange
LT	Lower Tester
MDU	Management Data Unit
MPH	Management Physical Layer
NT	Network Termination
NWK	Network layer
PDU	Protocol Data Unit
PICS	Protocol Implementation Conformance Statements
PL	Permanent Line
PSTN	Public Switched Telephone Network
REST	Restart
REVV	Verify and Re provisioning
SUT	System Under Test
TE	Terminal Equipment (ISDN or PSTN)
TI	Timer
TP	Test Purpose
TSS	Test Suite Structure
UNI	User Network Interface

4 Test Suite Structure (TSS)

4.1 TSS overview

Figure 1 shows the structure of the V5.1 AN side NWK test suite.

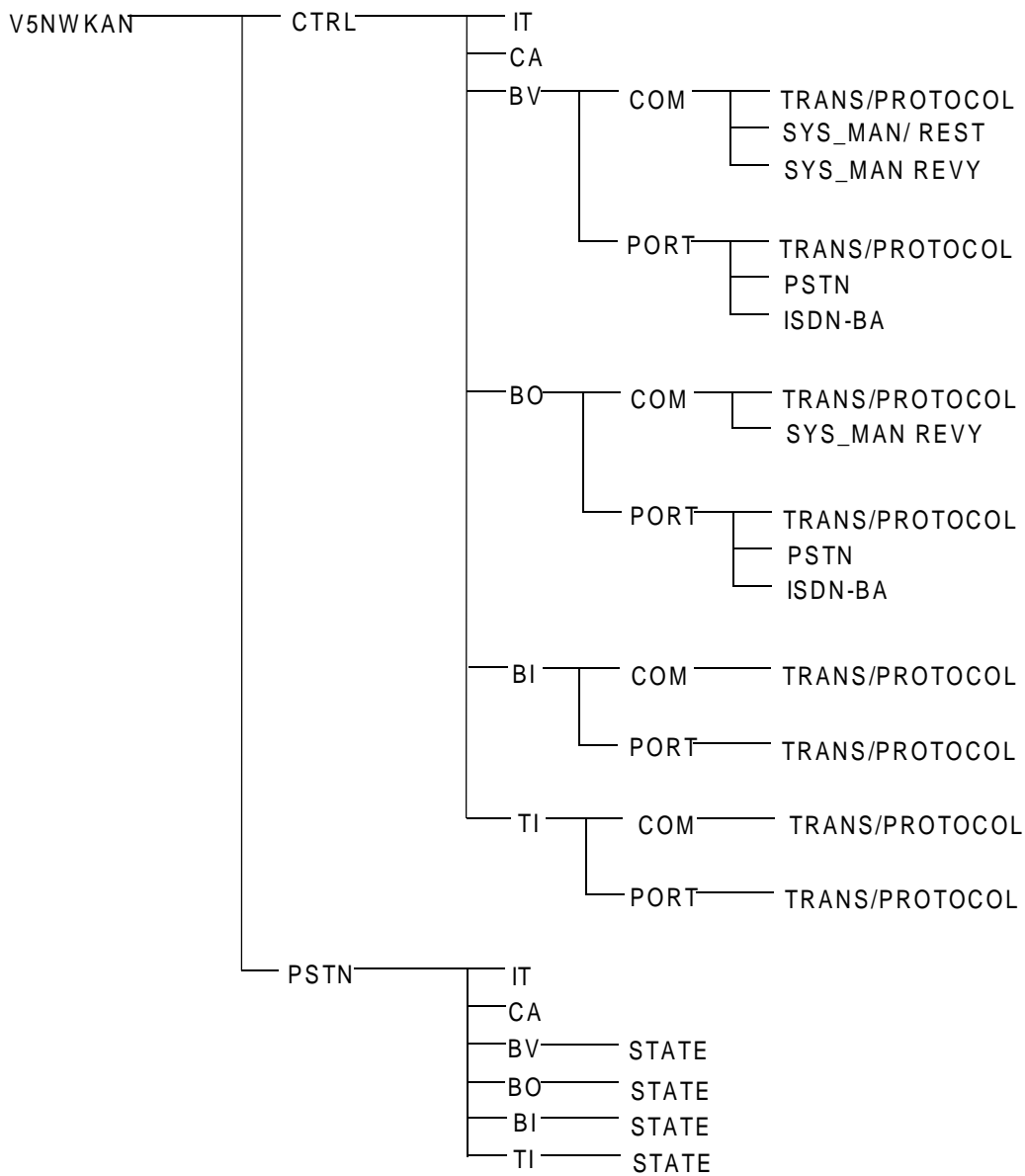

Figure 1: NWK AN TSS

4.2 Test groups

Figure 2 gives an overview of the various protocol entities of a V5.1 interface. Table 1 maps each protocol entity on tested protocol groups.

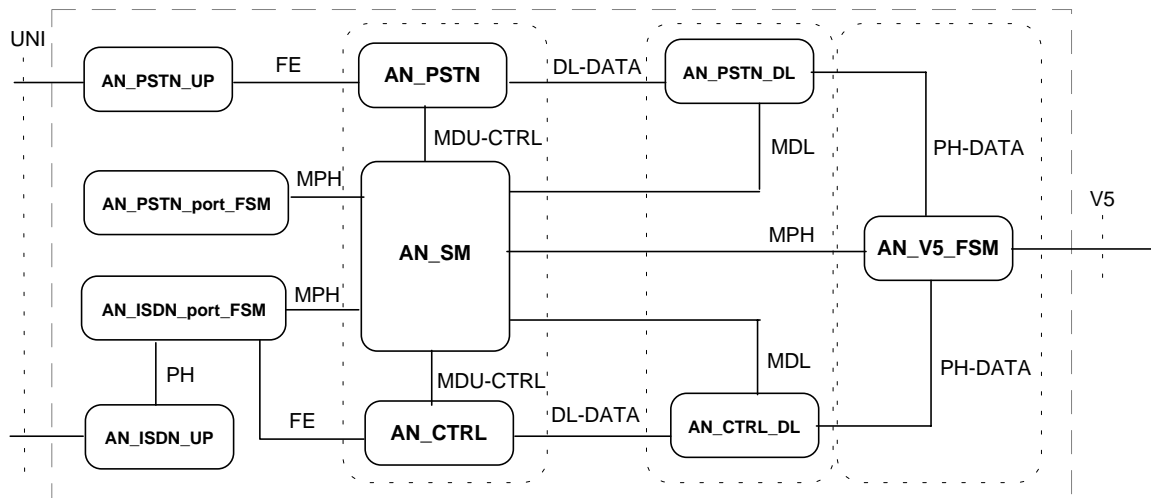

Figure 2: Network Layer AN - protocol entity overview

Table 1: Names used in figure 2 that correspond to ETS 300 324-1 [1]

NWK protocol entities	Protocol entities defined in ETS 300 324-1 [1]	Protocol group reference
AN_PSTN_UP	AN_PSTN_user_port	4.2.1.1
AN_PSTN_port_FSM	AN_PSTN_user_port_FSM	4.2.1.1
AN_ISDN_port_FSM	AN_ISDN_BA_user_port_FSM	4.2.1.1
AN_ISDN_UP	AN_ISDN_BA_user_port AN_ISDN_PRA_user_port	4.2.1.1
AN_CTRL	AN_control_protocol	4.2.1.1
AN_SYS	AN_system_management	4.2.1.1
AN_PSTN	AN_PSTN_protocol	4.2.1.2

4.2.1 Protocol groups

4.2.1.1 Control protocol

All tests in the Control protocol (V5NWKAN/CTRL) test group are intended to verify as thoroughly as possible the various procedures of the AN_control_protocol entity. Depending on provisioning the following configurations are covered:

AN_system_management: the startup, restart, re-provisioning and verification procedures of normal operation of the AN_system_management (V5NWKAN/CTRL/BV/COM/REST, V5NWKAN/CTRL/BV/COM/REVV) and V5NWKAN/CTRL/BO/COM/REVV) are tested.

AN_control_protocol: the normal and exceptional procedures of the AN_control_protocol are verified in the test groups V5NWKAN/CTRL/BV/COM/TRANS, V5NWKAN/CTRL/BO/COM/TRANS, V5NWKAN/CTRL/TI/COM/TRANS, V5NWKAN/CTRL/BV/PORT/TRANS, V5NWKAN/CTRL/BO/PORT/TRANS and V5NWKAN/CTRL/TI/PORT/TRANS. Contents of the AN_control_protocol values are not verified (e.g. the control function ID). The error handling procedures are verified in test groups V5NWKAN/CTRL/BI/COM/TRANS and V5NWKAN/CTRL/BI/PORT/TRANS.

AN_PSTN_user_port: the blocking, blocking request and co-ordinated unblocking procedures of the AN_PSTN_user_port_FSM are verified in the test group V5NWKAN/CTRL/BV/PORT/PSTN. The interworking of the AN_PSTN_user_port_FSM and the AN_PSTN_protocol entity is tested via the AN_system_management.

AN_ISDN-BA_user_port: the blocking, blocking request, co-ordinated unblocking and activation/deactivation procedures of the AN_ISDN-BA_user_port_FSM are verified in the test group V5NWKAN/CTRL/BV/PORT/ISDNBA and V5NWKAN/CTRL/BO/PORT/ISDNBA.

4.2.1.2 PSTN protocol

All tests in the PSTN protocol (V5NWKAN/PSTN) test group are intended to verify as thoroughly as possible the various procedures of the AN_PSTN_protocol entity.

The following PSTN procedures are covered:

- all path related normal operation procedures;
- significant path related exceptional procedures;
- the status enquiry procedure;
- the error handling procedures;
- the layer 3 error detection procedure;
- the port blocking procedure;
- the restart procedure.

4.2.2 Main test groups

4.2.2.1 Basic Interconnection (IT) tests

The IT test subgroup contains a basic set of TPs which assures that there is a sufficient conformance for interconnection and that the chosen parameters are valid for the configuration.

4.2.2.2 Capability (CA) tests

Capability testing provides a limited testing to ascertain the capabilities stated in the PICS can be observed.

4.2.2.3 Valid Behaviour (BV) tests

Predefined state transitions are considered as valid. The test purpose in the valid behaviour test subgroup cover as far as reasonable the verification of the normal and exceptional procedures of the various FSMs.

A valid test is a test where the message sequence and the message contents is considered as valid (no error indication shall be indicated).

4.2.2.4 Inopportune Behaviour (BO) tests

This test subgroup is intended to verify that the IUT is able to react properly in the case an inopportune protocol event occurring. Such an event is syntactically correct but occurs when it is not expected and an error indication is caused.

4.2.2.5 Invalid Behaviour (BI) tests

This test subgroup is intended to verify that the IUT is able to react properly having received an invalid PDU. An invalid PDU is defined as a syntactically incorrect message and therefore an error indication is caused.

4.2.2.6 Timer (TI) expiry and counter mismatch tests

Different timers and counters are defined to supervise the various state transitions. This test subgroup is intended to verify that the Finite State Machine (FSM) is reacting properly to an expiry of one of the timers or counter mismatch.

4.2.2.6.1 Timer expiry and counters of the Control protocol

Refer to ETS 300 324-1 [1], table 58.

- T01 PORT CONTROL message sent
- T02 COMMON CONTROL message sent

4.2.2.6.2 Timer expiry and counters of the PSTN protocol

Refer to ETS 300 324-1 [1], table 28.

- T1 Subscriber seizure/Line information ESTABLISH sent
- T2 Time out T1 or T2
- T3 DISCONNECT sent
- Tr SIGNAL or PROTOCOL PARAMETER received
- Tt SIGNAL sent

Refer to ETS 300 324-1 [1], subclause 13.5.5.

- S(S) Sequence number to be sent/transmitted in next message
- S(A) Sequence number on the last acknowledged message
- S(R) Sequence number to be received in next message
- M(S) Sequence number of transmitted message
- M(R) Sequence number of next received message

4.2.2.6.3 Timer expiry and counters of the AN system management

Refer to ETS 300 324-1 [1], annex C, table C.1.

- TR1 MDU-CTRL(restart request) to all PSTN protocol FSMs
- TR2 MDU-CTRL(restart request) to CTRL protocol
- TC1 CONTROL-DL establishment requested
- TC2 CONTROL-DL establishment requested
- TC3 PSTN-DL establishment requested

4.3 Test step structure

General dynamic behaviours are described in test steps which can be called from all ATCs within the ATS:

- state transitions (refer to subclause 4.3.1)
- preconditions (refer to subclause 4.3.2)
- preambles (refer to subclause 4.3.3)
- postambles (refer to subclause 4.3.4)
- status checks (refer to subclause 4.3.5)
- common behaviours (refer to subclause 4.3.6)

4.3.1 State transitions

The following subclauses identify the test steps used in the ATS. In general, each test step represents a state transition. For example in the PSTN protocol, PSTN_AN1_2 is the test step which brings the AN PSTN_protocol_FSM from PSTN_path_state AN1 to PSTN_path_state AN2. The state transitions are declared in the parenthesis (originating state - destination state) which follow the test step names.

Three groups of state transitions are defined:

- STARTUP** startup the V5.1 interface and put the IUT into the initial state as defined in subclause 5.1.5.
- CTRL** state transitions used to preamble and postamble the Control protocol before a test purpose can be performed.
- PSTN** state transitions used to preamble and postamble the PSTN protocol before a test purpose can be performed.

To test the V5.1 interface certain sequences (i.e. preamble) shall be executed to reach the state which is the subject for the TPs.

4.3.1.1 Startup of V5.1 interface

The startup procedure for a V5.1 interface depends on the provisioned data configuration. Therefore, the two PICS M1 and M2 (refer to subclause 6.5.1 of ETS 300 324-2 [2]) are used to define the implemented configuration of the IUT.

NOTE 1: ETS 300 324-2 [2] requires at least one of the two PICS to be set to "Yes".

PICS description:

- M1: ISDN-BA ports supported;
- M2: PSTN ports supported.

NOTE 2: One port of each supported type shall be provisioned in a way that the IUT tries to enter the operational state for these ports after system startup (see subclause 5.1.6).

Depending on the setting of the PICS, the startup procedure is described in figure 2. This flow diagram describes the test step called STARTUP_AN.

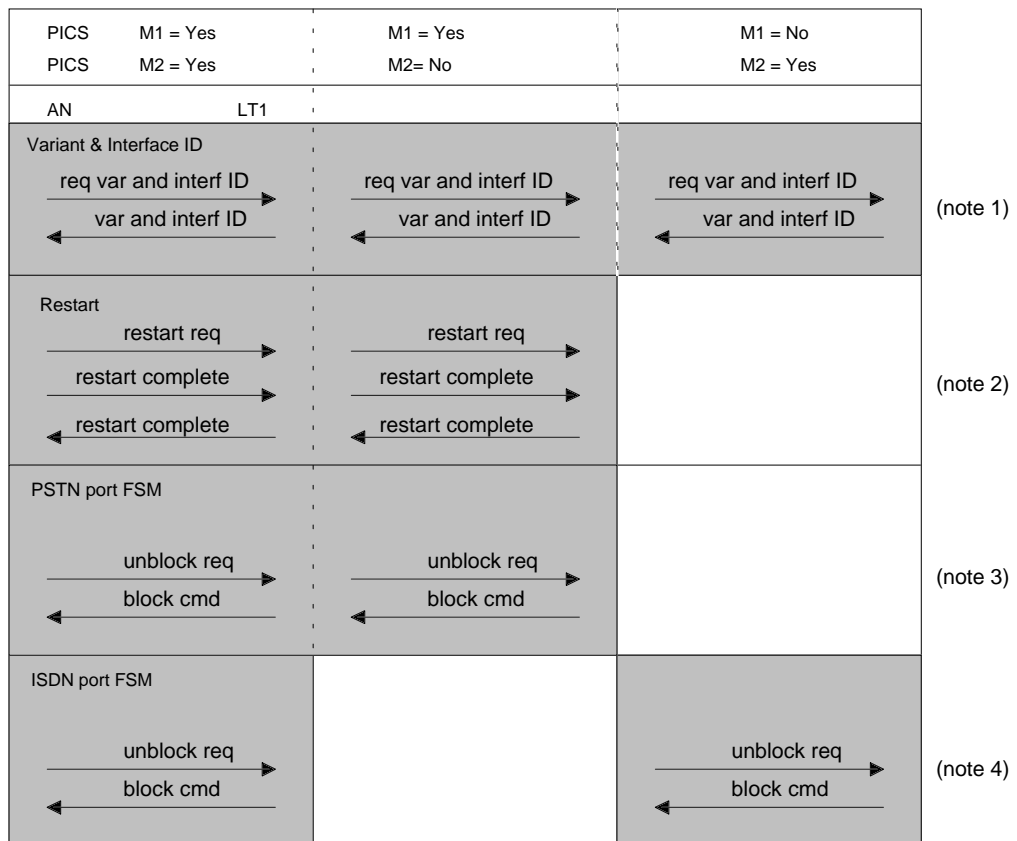

- NOTE 1: A test of the IUT's capability of receiving a request for the variant and interface ID is covered in subclause 5.2.3.1.1.
- NOTE 2: LT1 shall wait for the receipt of restart complete from the IUT before sending restart complete.
- NOTE 3: To reach the initial state of the IUT PSTN user port FSM as defined in subclause 5.1.5, the IUT's unblocking request is rejected by LT1. Before rejecting the unblock request, it shall be verified that the IUT PSTN protocol has entered the PSTN_path_state AN6 (Port blocked).
- NOTE 4: To reach the initial state of the ISDN-BA user port FSM as defined in subclause 5.1.5, the IUT's unblocking request is rejected by LT1.

Figure 3: STARTUP_AN flow diagram

4.3.1.2 Common control protocol (system management)

Refer to ETS 300 324-1 [1], table 60 and annex C.

CTRL_COM_AN0_1

On AN system startup (reset or initialization) the AN_CONTROL_DL is established between AN and LT1 and the Common and Port control protocol enter the In Service state AN1.

4.3.1.3 Control protocol (PSTN port FSM)

Refer to ETS 300 324-1 [1], table 40.

CTRL_PSTN_AN20_10

On receipt of a PORT CONTROL message containing the control_function_element IE FE203 (block_cmd) the IUT shall enter state AN1.0.

- NOTE 1: This results in a state transition of the PSTN protocol as well. The PSTN protocol of the affected port is forced to enter the PSTN_path_state AN6.

CTRL_PSTN_AN10_20

On receipt of a PORT CONTROL message containing the control_function_element IE FE201 (unblock_req) the IUT shall respond with the PORT CONTROL message containing the control_function_element IE FE202 (unblock_ack) and then enter state AN2.0.

NOTE 2: This results in a state transition of the PSTN protocol as well. The PSTN protocol of the affected port is forced to enter the PSTN_path_state AN1.

4.3.1.4 Control protocol (ISDN-BA port FSM)

Refer to ETS 300 324-1 [1], table 35.

CTRL_ISDNBA_AN20_10

On receipt of a PORT CONTROL message containing the control_function_element IE FE203 (block_cmd) the IUT shall enter state AN1.0.

CTRL_ISDNBA_AN10_20

On receipt of a PORT CONTROL message containing the control_function_element IE FE201 (unblock_req) the IUT shall respond with the PORT CONTROL message containing the control_function_element IE FE202 (unblock_ack) and then enter state AN2.0.

CTRL_ISDNBA_AN20_22

On receipt of a PORT CONTROL message containing the control_function_element IE FE101 (activate_access_req) the IUT shall enter state AN2.2 (access activated) when UNI reach successful activation and respond with a PORT CONTROL message containing the control_function_element IE FE104 (access_activated_ind).

CTRL_ISDNBA_AN22_20

On receipt of a PORT CONTROL message containing the control_function_element IE FE105 (deactivate_access_req) the IUT shall enter state AN2.0 (operational deactivated) when UNI reach successful deactivation and respond with a PORT CONTROL message containing the control_function_element IE FE106 (access_deactivated_ind).

4.3.1.5 PSTN protocol

Refer to ETS 300 324-1 [1], table 29.

All messages sent within the test steps shall be valid PSTN messages.

PSTN_ANx_6 ≡ CTRL_PSTN_AN20_10 (refer to subclause 4.3.1.3)

On receipt of a PORT CONTROL message containing the control_function_element IE FE203 (block_cmd) the PSTN protocol FSM shall enter the PSTN_path_state AN6.

PSTN_AN1_0

On receipt of a MDU_CTRL (restart_req) message the IUT shall send a COMMON CONTROL message containing the control_function_id IE "restart req".

The IUT shall send a COMMON CONTROL message containing the control_function_id IE "restart complete".

PSTN_AN6_1 ≡ CTRL_PSTN_AN10_20 (refer to subclause 4.3.1.3)

On receipt of a PORT CONTROL message containing the control_function_element IE FE201 (unblock_req) the IUT shall respond with the PORT CONTROL message containing the control_function_element IE FE202 (unblock_ack) and the PSTN protocol shall enter the PSTN_path_state AN1. The subscriber line shall be monitored for a subscriber seizure or line information condition. If this condition exists the IUT shall send an ESTABLISH message. (refer to ETS 300 324-1 [1], subclause 13.5.4.2).

PSTN_AN1_2

On receipt of an originating call attempt (FE-subscriber_seizure) the IUT shall send the message ESTABLISH and enter the PSTN_path_state AN2 (Path initiated by AN).

PSTN_AN2_3

On receipt of a FE-subscriber_release, the IUT shall enter the PSTN_path_state AN3.

PSTN_AN1_4

On receipt of the event FE-line_information, the IUT shall send the ESTABLISH message and enter the PSTN_path_state AN4.

PSTN_AN1_5

On receipt of the ESTABLISH message the IUT shall send the message ESTABLISH ACK and enter the PSTN_path_state AN5 (Path active).

PSTN_AN5_7

On receipt of a SIGNAL message containing a faulty sequence number the IUT PSTN protocol shall send a DISCONNECT message and enter the PSTN_path_state AN7.

4.3.2 Preconditions

The precondition step of a test group applies at the UP via the user interface as a Permanent Line (PL) condition. This line condition shall be permanent during all tests in that test group.

4.3.3 Preambles

The preamble test step group contains the test steps needed for initialization of the IUT before testing the particular test purpose. All combinations of the test steps defined in subclause 4.3.1.2 to subclause 4.3.1.5 can be used to create preambles. Each preamble shall start from the IUT initial state as defined in subclause 5.1.5.

4.3.4 Postambles

After each ATC the IUT shall be brought back to the initial state as defined in subclause 5.1.5. All combinations of the test steps defined in subclauses 4.3.1.2 to 4.3.1.5 can be used to create postambles.

4.3.5 Status verification

4.3.5.1 PSTN protocol

Based on ETS 300 324-1 [1], table 29, it is possible to identify the state of the IUT PSTN protocol FSM with valid PSTN messages.

On receipt of a STATUS ENQUIRY message the IUT shall send a STATUS message and remain the same state.

4.3.5.2 Port control protocol

CHECK_PC_DISCARD

Until time-out of timer T_NOAC no message shall appear on the V5.1 interface.

Afterwards teststep CTRL_PSTN_AN10_20 (refer to subclause 4.3.1.3) or CTRL_ISDNBA_AN10_20 (refer to subclause 4.3.1.4), depending on the affected port type is applied.

4.3.5.3 Common control protocol

CHECK_CC_DISCARD

Until time-out of timer T_NOAC no message shall appear on the V5.1 interface.

On receipt of a COMMON CONTROL message containing the control_function_id IE "request variant & interface ID" the IUT shall send a COMMON CONTROL ACK message and a COMMON CONTROL message containing the control_function_id IE "variant & interface ID".

Complete this teststep by sending a COMMON CONTROL ACK message.

4.3.6 Common test steps

This test step group shall contain procedures which are used in more than one ATC.

4.4 Defaults

The default section describes the behaviour in case of an unexpected test event.

4.5 Abstract Service Primitives (ASPs) and Protocol Data Units (PDUs)

4.5.1 ASPs

The format of the two used ASPs is defined as described in ETS 300 324-1 [1], subclause 13.4:

dl_data_req
dl_data_ind

The ASP shall transfer the V5DLaddr to the Data link Service Access Point (DSAP).

4.5.2 PDUs

4.5.2.1 Common control protocol

ctrl_common_control
ctrl_common_control_ack

4.5.2.2 Port control protocol

ctrl_port_control
ctrl_port_control_ack

4.5.2.3 PSTN protocol

pstn_establish
pstn_establish_ack
pstn_signal
pstn_signal_ack
pstn_disconnect
pstn_disconnect_complete
pstn_status_enquiry
pstn_status
pstn_protocol_parameter

4.5.3 Information elements

4.5.3.1 Variable length information elements

4.5.3.1.1 Control protocol

ctrl_control_function_element
ctrl_control_function_id
ctrl_variant
ctrl_interface_id

4.5.3.1.2 PSTN protocol

pstn_sequence_number
pstn_cadenced_ringing
pstn_pulsed_signal
pstn_steady_signal
pstn_digit_signal
pstn_recognition_time
pstn_enable_autonomous_ack
pstn_disable_autonomous_ack
pstn_cause
pstn_resource_unavailable

4.5.3.2 Single octet information elements

4.5.3.2.1 Control protocol

ctrl_performance_grading
ctrl_rejection_cause

4.5.3.2.2 PSTN protocol

pstn_pulse_notification
pstn_line_information
pstn_state
pstn_autonomous_signalling_sequence
pstn_sequence_response

4.6 Timers and counters of the Abstract Test Suite (ATS)

This subclause describes the timers and counters used in the ATS. The **min** and **max** indications define if the timer value represents the minimum or maximum limit of a timer. The timer values contain some additional tolerances for delays caused by test simulators. Therefore, a bigger timer tolerance is given than defined in ETS 300 324-1 [1]:

Minimum value of ATS timer = ETS timer - ETS tolerance.
Maximum value of ATS timer = ETS timer + 2 x ETS tolerance.

The repetition of messages by the IUT shall be tested in the following way: the message has to be repeated within the time period $T_{\min} < T < T_{\max}$. This testing procedure applies to the tests in the TI test group only.

NOTE: Maximum values of some ATS timers are defined as test suite parameters.

Timers used in the ATS are given in *Timer Declarations* part of the ATS.

Table 2 gives the identified protocol counters used in the ATS and the references to ETS 300 324-1 [1].

Table 2: Protocol counter values and references to ETS 300 324-1 [1]

ATS counter name	ATS counter value	Explanation	Reference to ETS 300 324-1 [1]
N01	1	Allowed number of repetition of the PORT CONTROL message	clause 14, table 59
N02	1	Allowed number of repetition of the COMMON CONTROL message	clause 14, table 60
N1	1	Number of repetitions of the ESTABLISH message before starting T2	clause 13, table 28
N2	3	Maximum number of tested repetitions of the ESTABLISH message	clause 13, table 28
N3	2	Allowed number of repetitions of the DISCONNECT message	clause 13, table 28

5 Test Purposes (TPs)

5.1 Introduction

For each test requirement, a TP is defined.

This subclause details the TPs for the AN side of NWK of the V5.1 interface for each test group and references to the corresponding ATCs.

At the beginning of each test subgroup the initial state (refer to subclause 5.1.5), the preambles (refer to subclause 4.3.3) and the postambles (refer to subclause 4.3.4) are listed.

5.1.1 TP naming convention

The identifier of the TP is constructed according to the scheme in table 4.

Table 3: TP identifier naming convention scheme

Identifier:	TP<t><c><g1><g2><tpt><s><ss><nn>			
<t>	=	type of protocol: (test group)	1 2	Control protocol PSTN protocol
<c>	=	category: (test subgroup)	1 2 3 4 5 6	IT, Basic Interconnection Tests CA, Capability Tests BV, Valid Behaviour Tests BO, Inopportune Behaviour Tests BI, Invalid Behaviour Tests TI, Timer Expiry and Counter Mismatch
<g1>	=	group level 1:	1 2 –	Common control Port control (underscore) not relevant
<g2>	=	group level 2:	1 2 3 4 5 –	Transport System management procedure Restart System management procedure Re-provisioning & Verification PSTN ISDN-BA (underscore) not relevant
<tpt>	=	test purpose type:	S –	Single (underscore) not relevant
<s>	=	state:	(0-9) M –	Multiple state transition (underscore) not relevant
<ss>	=	substate:	(0-9) –	(underscore) not relevant
<nn>	=	sequential number:	(01-99)	

5.1.2 Source of TP definition

The source for the TPs is based on ETS 300 324-1 [1], clauses 13 and 14, and annex C.

5.1.3 Test strategy

To achieve a maximum of test coverage with an appropriate number of abstract test cases the following selection criteria have been applied:

- a) only the first up to the third value of the PSTN sequence number variables S(S), S(A), S(R), M(S), M(R) is covered;
- b) the error handling procedures of the Control and PSTN protocol are not exhaustively tested. Not all possible combinations of protocol errors in all protocol states are covered. The TPs cover only examples for each error handling procedure:
 - 1) for the PSTN protocol applications the error handling procedures are tested in PSTN_path_state AN1. To easily perform some of the test cases, some procedures are tested in PSTN_path_state AN5;
 - 2) for the Control protocol applications the error handling procedures are tested in state AN1 of the Common and Port control protocol. During these tests the PSTN and ISDN-BA user port FSMs stay in state AN1.0.

The procedure for unexpected events of the PSTN protocol is exhaustively tested (all unexpected events in all PSTN_path_states are covered);

- c) for several TPs some activities by the testing person are requested (invoking of certain procedures by the System Under Test (SUT)). These TPs are marked with (*);
- d) the Port control protocol, the Common control protocol (COM), the ISDN user port FSM and the PSTN user port FSM are not tested on a per-state basis. The TPs step through the FSMs by testing the procedures and supervising the behaviour of the IUT on the interface.

5.1.4 Requirements not covered by TPs

- a) it is not possible to explicitly verify the state of the COM, the Port control protocol, the ISDN-BA user port FSM and the PSTN user port FSM;
- b) the correct use and implementation of national dependent optional IEs within the PSTN protocol is not tested (refer to annex D of ETS 300 324-1 [1]):
 - 1) the capability of the AN to send PSTN messages in all sequences required by the implemented national mapping;
 - 2) the capability of the AN to send PSTN messages containing all combinations of optional IEs required by the implemented national mapping;
- c) state transitions which are defined by the characters "/" or "-" are only tested if the events are V5-messages or timer expirations;
- d) as the system reaction on the time-out of system management timers is not specified, these time outs are not tested;
- e) generating of error indications is not tested;
- f) activation of the ISDN user port for the PL capability is only tested concerning those states and state transitions which have relevance to the V5.1 interface.

5.1.5 Initial state

The initial states of the various V5.1 protocols are defined as follows:

CTRL_COM_INIT AN1	Initial state to start the preamble of the CTRL_COM protocol TPs (In Service), for COM
CTRL_PORT_INIT AN1 AN1.0	Initial state to start the preamble of the CTRL_PORT protocol TPs (In Service), for Port control protocol (Blocked), valid for both ISDN-BA and PSTN user port FSMs
PSTN_INIT AN6	Initial state to start the preamble of the PSTN TPs (Port blocked), for PSTN protocol FSMs

5.1.6 Test and data configuration requirements

According to ETS 300 324-2 [2], the IUT shall support either ISDN-BA ports or PSTN ports or both. For the aim of the conformance testing only one port of each supported type shall be provisioned.

Each user port shall be provisioned in a way that the IUT tries to enter the operational state for these user ports after system startup.

5.2 Control protocol

5.2.1 Basic interconnection tests (V5NWKAN/CTRL/IT)

Initial state of the IUT: power on
Preamble: reset IUT
Postamble: -

TP11__SM_01 Run the test step STARTUP_AN (subclause 4.3.1.1).

5.2.2 Capability tests (V5NWKAN/CTRL/CA)

Refer to ETS 300 324-1 [1], tables 59 and 60.

Initial state of the IUT: CTRL_COM_INIT, CTRL_PORT_INIT
Preamble: -
Postamble: -

TP12__S1_01 On receipt of a COMMON CONTROL message containing the control_function_id IE "variant & interface id", the IUT shall send a COMMON CONTROL ACK message containing the same control_function_id IE.

TP12__S1_02 On receipt of a PORT CONTROL message containing the control_function_element IE FE203 (block_cmd), the IUT shall send a PORT CONTROL ACK message containing the same control_function_element IE.

5.2.3 Valid behaviour tests (V5NWKAN/CTRL/BV)

5.2.3.1 V5NWKAN/CTRL/BV/COM

5.2.3.1.1 V5NWKAN/CTRL/BV/COM/TRANS

Refer to ETS 300 324-1 [1], table 60 and figures L.12.1 to L.12.2.

Initial state of the IUT: CTRL_COM_INIT, CTRL_PORT_INIT
Preamble: CTRL_PSTN_AN20_10, CTRL_ISDNBA_AN20_10
Postamble: -

TP1311S1_01 Refer to TP12__S1_01 in subclause 5.2.2.

TP1311S1_02 On receipt of a MDU-CTRL (request variant & interface id) the IUT shall send a
(*) COMMON CONTROL message containing the control_function_id IE "request variant & interface id".

On receipt of a COMMON CONTROL ACK message containing the control_function_id IE "request variant & interface id" the IUT shall not repeat the original message.

TP1311SM_03 Check that the IUT is able to control messages in both directions at the same time:

Preamble:
On receipt of a COMMON CONTROL message containing the control_function_id IE "request variant & interface ID" the IUT shall send a COMMON CONTROL ACK message.

On receipt of a MDU-CTRL (variant & interface ID) the IUT shall send a COMMON CONTROL message containing the control_function_id IE "variant & interface ID". On receipt of a COMMON CONTROL message containing the control_function_id IE "variant & interface id", the IUT shall send a COMMON CONTROL ACK message containing the same control_function_id IE. On receipt of a COMMON CONTROL ACK message containing the control_function_id IE "variant & interface ID", the IUT shall not repeat the original message.

5.2.3.1.2 V5NWKAN/CTRL/BV/COM/REST

Refer to ETS 300 324-1 [1], table 60, annex C and figures L.17.1 to L.17.10.

As the COM is tested separately (refer to subclause 5.2.3.1.1), the COMMON CONTROL ACK messages are not mentioned in the following TPs.

NOTE: This test group is only valid if PICS M2 is set to "Yes" (see ETS 300 324-2 [2]).

Initial state of the IUT: CTRL_COM_INIT, CTRL_PORT_INIT
Preamble: -
Postamble: sending of a COMMON CONTROL message containing the control_function_id IE "restart complete".

TP1312SM_01 On receipt of a MDU_CTRL (restart_req) the IUT shall send a COMMON CONTROL
(*) message containing the control_function_id IE "restart req". The IUT shall send a COMMON CONTROL message containing the control_function_id IE "restart complete".

TP1312SM_02 On receipt of a COMMON CONTROL message containing the control_function_id IE "restart req" the IUT shall send a COMMON CONTROL message containing the control_function_id IE "restart complete".

5.2.3.1.3 V5NWKAN/CTRL/BV/COM/REVY

Refer to ETS 300 324-1 [1], tables 64 and 66, annex C and figures L.17.1 to L.17.10.

As the COM is tested separately (refer to subclause 5.2.3.1.1), the COMMON CONTROL ACK messages are not mentioned in the following TPs.

Initial state of the IUT: CTRL_COM_INIT, CTRL_PORT_INIT
Preamble: CTRL_PSTN_AN20_10, CTRL_ISDNBA_AN20_10
Postamble: -

- TP1313S0_01 (note 1) Refer to TP1311SM_03 in subclause 5.2.3.1.1.
- TP1313S0_02 (note 1) On receipt of a COMMON CONTROL message containing the control_function_id IE "verify re-provisioning" and the current variant IE, the IUT shall send a COMMON CONTROL message containing the control_function_id IE "not ready for re-provisioning".
- TP1313S0_03 (note 2) On receipt of a COMMON CONTROL message containing the control_function_id IE "verify re-provisioning" and an unknown variant IE, the IUT shall send a COMMON CONTROL message containing the control_function_id IE "not ready for re-provisioning" and the rejection_cause IE "unknown variant".
- TP1313S0_04 (note 2) On receipt of a COMMON CONTROL message containing the control_function_id IE "switch-over to new variant" and an unknown variant IE the IUT shall send a COMMON CONTROL message containing the control_function_id IE "cannot re-provision" and the rejection_cause IE "unknown variant".
- TP1313S0_05 (note 2) On receipt of a COMMON CONTROL message containing the control_function_id IE "cannot re-provision" the IUT shall send a COMMON CONTROL ACK message, but no further event shall appear on the V5 interface.
- TP1313SM_06 (*) (note 2) On receipt of data_set_available the IUT shall send a COMMON CONTROL message containing the control_function_id IE "switch over to new variant" and the new variant IE.

On receipt of a COMMON CONTROL message containing the control_function_id IE "switch over to new variant" and the new variant IE the IUT shall send a COMMON CONTROL message containing the control_function_id IE "re-provisioning started" and the new variant- and interface_id IEs.
- TP1313SM_07 (*) (note 2) On receipt of a COMMON CONTROL message containing the control_function_id IE "request variant & interface id" the IUT shall send a COMMON CONTROL message containing the control_function_id IE "variant and interface id" and the current variant- and interface_id IEs.

On receipt of a COMMON CONTROL message containing the control_function_id IE "verify re-provisioning" and the new variant IE the IUT shall send a COMMON CONTROL message containing the control_function_id IE "ready for re-provisioning" and the new variant IE.

On receipt of a COMMON CONTROL message containing the control_function_id IE "switch-over to new variant" and the new variant IE the IUT shall send a COMMON CONTROL message containing the control_function_id IE "re-provisioning started" and the new variant IE.

TP1313SM_08 (*)
(note 2) On receipt of data_set_available the IUT shall send a COMMON CONTROL message containing the control_function_id IE "switch over to new variant" and the new variant IE.

On receipt of a COMMON CONTROL message containing the control_function_id IE "verify re-provisioning" and the current variant IE the IUT shall send a COMMON CONTROL message containing the control_function_id IE "not ready for re-provisioning".

TP1313SM_09 (*)
(note 2) On receipt of data_set_available the IUT shall send a COMMON CONTROL message containing the control_function_id IE "switch over to new variant" and the new variant IE.

On receipt of a COMMON CONTROL message containing the control_function_id IE "verify re-provisioning" and an unknown variant IE the IUT shall send a COMMON CONTROL message containing the control_function_id IE "not ready for re-provisioning".

NOTE 1: Applicable if PICS P5.2 is set to "Yes" (see ETS 300 324-2 [2]).

NOTE 2: Applicable if PICS P5.2 and P5.3 are set to "Yes" (see ETS 300 324-2 [2]).

5.2.3.2 V5NWKAN/CTRL/BV/PORT

5.2.3.2.1 V5NWKAN/CTRL/BV/PORT/TRANS

Refer to ETS 300 324-1 [1], table 59 and figures L.11.1 to L.11.2.

All the PORT CONTROL TRANS protocol TPs are tested separately.

Initial state of the IUT: CTRL_COM_INIT, CTRL_PORT_INIT
Preamble: -
Postamble: -

TP1321S2_01 Refer to TP12__S1_02 in subclause 5.2.2.

TP1321S2_02 (*) On receipt of a PORT CONTROL ACK containing the control_function_element IE FE204 (block_cmd) after sending a PORT CONTROL message containing the control_function_element IE FE204 (block_cmd), the IUT shall not repeat the original message.

TP1321SM_03 (*) Check that the IUT is able to control messages in both directions at the same time:
On receipt of a FE204 (block_cmd) the IUT shall send a PORT CONTROL message containing the control_function_element IE FE204 (block_cmd). On receipt of a PORT CONTROL message containing the control_function_element IE FE203 (block_cmd), the IUT shall send a PORT CONTROL ACK message containing the same control_function_element IE. On receipt of a PORT CONTROL ACK message containing the control_function_element IE FE204 (block_cmd), the IUT shall not repeat the original message.

5.2.3.2.2 V5NWKAN/CTRL/BV/PORT/PSTN

Refer to ETS 300 324-1 [1], table 40 and figures L.15.1 to L.15.3.

As the Port control protocol is tested separately (refer to subclause 5.2.3.2.1), the PORT CONTROL ACK messages are not mentioned in the following TPs.

NOTE: This test group is only valid if PICS M2 is set to "Yes" (see ETS 300 324-2 [2]).

Initial state of the IUT: CTRL_COM_INIT, CTRL_PORT_INIT
Preamble: CTRL_PSTN_AN20_10
Postamble: CTRL_PSTN_AN20_10

TP1324S1001 (*) On receipt of a MPH-BR (block_req) message the IUT shall remain in the PSTN_path_state AN6.

On receipt of a message containing the control_function_element IE FE203 (block_cmd) the IUT PSTN protocol FSM remains in the PSTN_path_state AN6.

TP1324S1002 (*) Verify "Local blocking " procedure:

On receipt of a MPH-BI (block_cmd) the IUT shall send a message containing the control_function_element IE FE204 (block_cmd) and the IUT PSTN protocol FSM shall remain in the PSTN_path_state AN6.

TP1324SM_03 (*) Verify "Local Unblocking/Blocking" procedure in different states:

On receipt of a MPH-UBR (unblock_req) the IUT shall send a message containing the control_function_element IE FE202 (unblock_req).

On receipt of a message containing the control_function_element IE FE201 (unblock_ack) the IUT PSTN protocol FSM shall enter PSTN_path_state AN1.

On receipt of a MPH-UBR (unblock_req) the IUT shall send a message containing the control_function_element IE FE202 (unblock_req) the IUT PSTN protocol FSM shall remain PSTN_path_state AN1.

On receipt of a MPH-BI (block_cmd) the IUT shall send a message containing the control_function_element IE FE204 (block_cmd) and the IUT PSTN protocol FSM shall enter PSTN_path_state AN6.

TP1324SM_04 Verify "Remote Unblocking/Blocking" procedure in different states:

On receipt of a message containing the control_function_element IE FE201 (unblock_req) the IUT shall send a message containing the control_function_element IE FE202 (unblock_ack) and the IUT PSTN protocol FSM shall enter PSTN_path_state AN1.

On receipt of a message containing the control_function_element IE FE201 (unblock_req) the IUT shall send a message containing the control_function_element IE FE202 (unblock_ack) and the IUT PSTN protocol FSM shall remain PSTN_path_state AN1.

On receipt of a message containing the control_function_element IE FE203 (block_cmd) the IUT PSTN protocol FSM shall enter PSTN_path_state AN6.

- TP1324SM_05 (*) Verify "Rejected Unblocking" procedure:
- On receipt of a MPH-UBR (unlock_req) the IUT shall send a message containing the control_function_element IE FE202 (unlock_req).
- On receipt of a message containing the control_function_element IE FE203 (block_cmd) the IUT PSTN protocol FSM shall remain PSTN_path_state AN6.
- TP1324SM_06 (*) Verify "Cancelled Unblocking" procedure:
- On receipt of a MPH-UBR (unlock_req) the IUT shall send a message containing the control_function_element IE FE202 (unlock_req).
- On receipt of a MPH-BI (block_cmd) the IUT shall send a message containing the control_function_element IE FE204 (block_cmd) and the IUT PSTN protocol FSM shall remain PSTN_path_state AN6.
- TP1324SM_07 (*) Verify "Repeated local unblocking":
- On receipt of a MPH-UBR (unlock_req) the IUT shall send a message containing the control_function_element IE FE202 (unlock_req).
- On receipt of a MPH-UBR (unlock_req) a second time the IUT shall repeat the message containing the control_function_element IE FE202 (unlock_req).
- On receipt of a message containing the control_function_element IE FE201 (unlock_ack) the IUT PSTN protocol FSM shall enter PSTN_path_state AN1.
- On receipt of a MPH-UBR (unlock_req) the IUT shall send a message containing the control_function_element IE FE202 (unlock_req) the IUT PSTN protocol FSM shall remain PSTN_path_state AN1.
- On receipt of a MPH-BI (block_cmd) the IUT shall send a message containing the control_function_element IE FE204 (block_cmd) and the IUT PSTN protocol FSM shall enter PSTN_path_state AN6.

5.2.3.2.3 V5NWKAN/CTRL/BV/PORT/ISDNBA

Refer to ETS 300 324-1 [1], table 35 and figures L.14.1 to L.14.8.

As the Port control protocol is tested separately (refer to subclause 5.2.3.2.1), the PORT CONTROL ACK messages are not mentioned in the following TPs.

NOTE 1: This test group is only valid if PICS M1 is set to "Yes" (see ETS 300 324-2 [2]).

Initial state of the IUT: CTRL_COM_INIT, CTRL_PORT_INIT
Preamble: CTRL_ISDNBA_AN20_10
Postamble: CTRL_ISDNBA_AN20_10

TP1325SM_01 Verify the AN "Local blocking/unblocking".
(*)

On receipt of a message containing the control_function_element IE FE201 (unlock_req) the IUT shall send a message containing the control_function_element IE FE202 (unlock_ack) and the IUT ISDN-BA user port FSM shall enter state "Operational deactivated", AN2.0.

On receipt of a message containing the control_function_element IE FE105 (deactivate_access_req) the IUT shall send a message containing the control_function_element IE FE106 (access_deactivated).

On receipt of a message containing the control_function_element IE FE201 (unlock_req) the IUT shall send a message containing the control_function_element IE FE202 (unlock_ack).

On receipt of a local block_req (MPH-BR) the IUT shall send a message containing the control_function_element IE FE205 (block_req).

On receipt of a message containing the control_function_element IE FE203 (block_cmd) and the IUT ISDN-BA user port FSM shall return back to the state "Blocked", AN1.0.

TP1325SM_02 Verify the AN "Cancelled unblocking".
(*)

On receipt of a message containing the control_function_element IE FE201 (unlock_req) the IUT shall send a message containing the control_function_element IE FE202 (unlock_ack) and the IUT ISDN-BA user port FSM shall enter state "Operational deactivated", AN2.0.

On receipt of a local unblock_req (MPH-UBR) the IUT shall send a message containing the control_function_element IE FE202 (unlock_req).

On receipt of a local block_req (MPH-BR) the IUT shall send a message containing the control_function_element IE FE205 (block_req).

On receipt of a local block_cmd (MPH-BI) the IUT shall send a message containing the control_function_element IE FE204 (block_cmd) and the IUT ISDN-BA user port FSM shall return to the state "Blocked", AN1.0.

- TP1325SM_03
(*)
- Verification of events in state AN1.0, "Local unblock".
- On receipt of a local unblock_req (MPH-UBR) the IUT shall send a message containing the control_function_element IE FE202 (unblock_req).
- On receipt of a local unblock_req (MPH-UBR) the second time, the IUT shall send a message containing the control_function_element IE FE202 (unblock_req) once more.
- On receipt of a local block_cmd (MPH-BI) the IUT shall send a message containing the control_function_element IE FE204 (block_cmd) and the IUT ISDN-BA user port FSM shall enter the state "Blocked", AN1.0.
- TP1325SM_04
(*)
- Verify AN user interface initiated activation by a Terminal Equipment (TE).
- On receipt of a message containing the control_function_element IE FE201 (unblock_req) the IUT shall send a message containing the control_function_element IE FE202 (unblock_ack) and the IUT ISDN-BA user port FSM shall enter state "Operational deactivated", AN2.0.
- On "Off hook" (event FE2) generated by an ISDN-BA TE connected to an interface in state "Operational deactivated", the AN shall generate a message containing the control_function_element IE FE102 (activation_initiated_by_user_ind).
- On fully activated user interface (event FE4) the IUT shall send a message containing the control_function_element IE FE104 (access_activated_ind).
- TP1325SM_05
(*)
- Verify activation initiated by the network (LT1)
- On receipt of a message containing the control_function_element IE FE201 (unblock_req) the IUT shall send a message containing the control_function_element IE FE202 (unblock_ack) and the IUT ISDN-BA user port FSM shall enter state "Operational deactivated", AN2.0.
- On receipt of a message containing the control_function_element IE FE101 (activate_access_req (terminating call)) the IUT shall activate the UNI within time T1 (see ETS 300 297 [3]) and send a message containing the control_function_element IE FE104 (access_activated_ind).
- On receipt of the same message containing the control_function_element IE FE101 (activate_access_req (terminating call)) the IUT shall send a message containing the control_function_element IE FE104 (access_activated_ind).
- On receipt of the a message containing the control_function_element IE FE105 (deactivate_access_req (end of last call)) the IUT shall send a message containing the control_function_element IE FE106 (access_deactivated_ind).
- The ISDN-BA User Port FSM returns to the "Operational deactivated" state.

- TP1325SM_06
(*) Verify blocking/unblocking request on activated access.
- On receipt of a message containing the control_function_element IE FE201 (unlock_req), the IUT shall send a message containing the control_function_element IE FE202 (unlock_ack) and the IUT ISDN-BA user port FSM shall enter state "Operational deactivated", AN2.0.
- On receipt of a message containing the control_function_element IE FE101 (activate_access_req (terminating call)); the IUT shall activate the UNI within time T1 (see ETS 300 297 [3]) and send a message containing the control_function_element IE FE104 (access_activated_ind).
- On receipt of a local unlock_req (MPH-UBR) the IUT shall send a message containing the control_function_element IE FE202 (unlock_req).
- On receipt of a local block_req (MPH-BR) the IUT shall send a message containing the control_function_element IE FE205 (block_req).
- On receipt of a local block_cmd (layer 1 failure) (MPH-BI) the IUT shall send a message containing the control_function_element IE FE204 (block_cmd) and the IUT ISDN-BA user port FSM shall remain the state "Blocked", AN1.0.
- TP1325S2207
(*) On receipt of grading in the AN_ISDN-BA_user_port the IUT shall send a FE206_grading. The IUT shall remain the port state AN2.2 (Access activated).
- TP1325S2208
(*) On receipt of a FE207 (D-channel_block), the IUT shall remain the port state AN2.2 (Access activated).
- TP1325S2209
(*) On receipt of a FE208 (D-channel_unlock) the IUT shall remain the port state AN2.2 (Access activated).
- TP1325SM_10
(*)
(note 2) Verify "PL take over by AN":
- Preamble the user port into state AN3.1 (PL activation initiated).
- The system management shall bring the IUT from state AN3.1 to AN3.2 automatically as defined in ETS 300 324 [1] subclause 14.1.3.3.5.2.
- On receipt of a deactivate_req (MPH-DR) the IUT shall send a message containing the control_function_element IE FE204 (block_cmd) and the IUT ISDN-BA user port FSM shall enter the state "Blocked", AN1.0.
- TP1325SM_11
(*)
(note 2) Verify "PL take over by LE":
- Preamble the user port into state AN3.1 (PL activation initiated).
- The system management shall bring the IUT from state AN3.1 to AN3.2 automatically as defined in ETS 300 324 [1] subclause 14.1.3.3.5.2.
- On receipt of a message containing the control_function_element IE FE201 (unlock_req) the IUT shall send a message containing the control_function_element IE FE104 (access_activated_ind).

NOTE 2: Applicable if PICS M7 is set to "Yes" (see ETS 300 324-2 [2]).

5.2.4 Inopportune behaviour tests (V5NWKAN/CTRL/BO)

Refer to ETS 300 324-1 [1], subclause 14.4.4.2.

5.2.4.1 V5NWKAN/CTRL/BO/COM

5.2.4.1.1 V5NWKAN/CTRL/BO/COM/TRANS

Refer to ETS 300 324-1 [1], table 60.

Initial state of the IUT: CTRL_COM_INIT, CTRL_PORT_INIT

Preamble: -

Postamble: -

TP1411S1_01 On receipt of a COMMON CONTROL ACK message the IUT shall ignore the message.

5.2.4.1.2 V5NWKAN/CTRL/BO/COM/REVV

Refer to ETS 300 324-1 [1], table 66.

NOTE: This test group is only valid if PICS P5.3 is set to "Yes" (see ETS 300 324-2 [2]).

Initial state of the IUT: CTRL_COM_INIT, CTRL_PORT_INIT

Preamble: CTRL_PSTN_AN20_10, CTRL_ISDNBA_AN20_10

Postamble: -

TP1413S0_01 On receipt of a COMMON CONTROL message containing the control_function_id IE "switch-over to new variant" and the current variant IE the IUT shall send a COMMON CONTROL ACK message, but no further event shall appear on the V5 interface.

TP1413S0_02 On receipt of a COMMON CONTROL message containing the control_function_id IE "reprovisioning started" the IUT shall send a COMMON CONTROL ACK message, but no further event shall appear on the V5 interface.

5.2.4.2 V5NWKAN/CTRL/BO/PORT

5.2.4.2.1 V5NWKAN/CTRL/BO/PORT/TRANS

Refer to ETS 300 324-1 [1], table 59.

Initial state of the IUT: CTRL_COM_INIT, CTRL_PORT_INIT

Preamble: CTRL_PSTN_AN20_10, CTRL_ISDNBA_AN20_10

Postamble: -

TP1421S1_01 On receipt of a PORT CONTROL ACK message the IUT shall ignore the message.

5.2.4.2.2 V5NWKAN/CTRL/BO/PORT/PSTN

Refer to ETS 300 324-1 [1], table 40 and figures L.15.1 to L.15.3.

As the Port control protocol is tested separately (refer to subclause 5.2.3.2.1), the PORT CONTROL ACK messages are not mentioned in the following TPs.

NOTE: This test group is only valid if PICS M1 is set to "Yes" (see ETS 300 324-2 [2]).

Initial state of the IUT: CTRL_COM_INIT, CTRL_PORT_INIT
Preamble: CTRL_PSTN_AN20_10
Postamble: CTRL_PSTN_AN20_10

TP1424S1101 Preamble into state AN1.1 (local unblock)
(*)

On receipt of a MPH-BR (block_req) message when the AN already requested MPH-UBR (unblock_req) is co-ordinated in the system management of AN as an answer on the sent message FE202 (unblock req) to LE.

5.2.4.2.3 V5NWKAN/CTRL/BO/PORT/ISDNBA

Refer to ETS 300 324-1 [1], table 35 and figures L.14.1 to L.14.8.

As the Port control protocol is tested separately (refer to subclause 5.2.3.2.1), the PORT CONTROL ACK messages are not mentioned in the following TPs.

NOTE: This test group is only valid if PICS M1 is set to "Yes" (see ETS 300 324-2 [2]).

Initial state of the IUT: CTRL_COM_INIT, CTRL_PORT_INIT
Preamble: CTRL_ISDNBA_AN20_10
Postamble: CTRL_ISDNBA_AN20_10

TP1425SM_01 On receipt of service grading (MPH-GI) the IUT shall send no message in the blocked
(*) state.

TP1425SM_02 On receipt of a FE207 (D-channel_block), the IUT shall remain in the port state AN1.0
(Blocked).

On receipt of a FE208 (D-channel_unblock), the IUT shall remain in the port state AN1.0 (Blocked).

5.2.5 Invalid behaviour tests (V5NWKAN/CTRL/BI)

Refer to ETS 300 324-1 [1], subclause 14.4.4.2.

5.2.5.1 V5NWKAN/CTRL/BI/COM

5.2.5.1.1 V5NWKAN/CTRL/BI/COM/TRANS

Initial state of the IUT: CTRL_COM_INIT
Preamble: CTRL_PSTN_AN20_10, CTRL_ISDNBA_AN20_10
Postamble: -

TP1511S1_01 Check that the IUT discards messages having less than 4 octets.

TP1511S1_02 (protocol discriminator error)

Check that the IUT discards a message containing an unspecified protocol_discriminator IE.

TP1511S1_03 (L3 address error)

Check that the IUT discards a message containing an unspecified L3addr IE.

TP1511S1_04 (message type error)

Check that the IUT discards a message containing an unspecified message_type IE.

- TP1511S1_05 (repeated optional IE)
Check that the IUT sends an ACK message after receipt of a message containing the control_function_id IE "Request variant & interface id" and two repeated interface_id IEs.
- TP1511S1_06 (repeated mandatory IE)
Check that the IUT discards a message containing two repeated control_function_id IE.
- TP1511S1_07 (mandatory IE missing)
Check that the IUT discards a message containing no control_function_id IE.
- TP1511S1_08 (unrecognized IE)
Check that the IUT sends an ACK message after receipt of a message containing the control_function_id IE "variant & interface id" and an unspecified IE.
- TP1511S1_09 (content error of mandatory IE)
Check that the IUT discards a message containing an incorrect control_function_id IE.
- TP1511S1_10
Check that the IUT discards a message containing an optional variant id IE whose length element has an incorrect value.
- TP1511S1_11
Check that the IUT, after having send a COMMON CONTROL message, discards a COMMON CONTROL ACK message which contains an optional IE.
- TP1511S1_12
Check that the IUT discards a message containing the control_function_id "variant & interface id" and no interface_id IE.

5.2.5.2 V5NWKAN/CTRL/BI/PORT

5.2.5.2.1 V5NWKAN/CTRL/BI/PORT/TRANS

Initial state of the IUT: CTRL_COM_INIT, CTRL_PORT_INIT

Preamble: -

Postamble: -

- TP1521S1_01 Refer to TP1511S1_01 in subclause 5.2.5.1.1.
- TP1521S1_02 (protocol discriminator error)
Check that the IUT discards a message containing an unspecified protocol_discriminator IE.
- TP1521S1_03 (L3 address error)
Check that the IUT discards a message containing an unprovisioned L3addr IE.
- TP1521S1_04 (message type error)
Check that the IUT discards a message containing an unspecified message_type IE.
- TP1521S1_06 (repeated mandatory IE)
Check that the IUT discards a message containing two repeated control_function_element IEs.

- TP1521S1_07 (mandatory IE missing)
Check that the IUT discards a message containing no control_function_element IE.
- TP1521S1_08 (unrecognized IE)
Check that the IUT sends an ACK message after receipt of a message containing the control_function_element IE FE205 and an additional unspecified optional IE.
- TP1521S1_09 (content error of mandatory IE)
Check that the IUT discards a message containing an incorrect control_function_element IE.

5.2.6 Timer expiry and counter mismatch tests (V5NWKAN/CTRL/TI)

5.2.6.1 V5NWKAN/CTRL/TI/COM

5.2.6.1.1 V5NWKAN/CTRL/TI/COM/TRANS

Refer to ETS 300 324-1 [1], tables 58 and 60, figures L.12.1 to L.12.2.

Initial state of the IUT: CTRL_COM_INIT, CTRL_PORT_INIT

Preamble: -

Postamble: -

TP1611S2_01 Preamble:
On receipt of a COMMON CONTROL message containing the control_function_id IE "request variant & interface ID" the IUT shall send a COMMON CONTROL ACK message containing the same control_function_id IE.

On receipt of a MDU-CTRL (variant & interface ID) the IUT shall send a COMMON CONTROL message containing the control_function_id IE "variant & interface ID". On time-out of timer T02 the IUT shall repeat sending the COMMON CONTROL message N02 times.

TP1611S2_02 Preamble:
On receipt of a COMMON CONTROL message containing the control_function_id IE "request variant & interface ID" the IUT shall send a COMMON CONTROL ACK message containing the same control_function_id IE.

On receipt of a MDU-CTRL (variant & interface ID) the IUT shall send a COMMON CONTROL message containing the control_function_id IE "variant & interface ID". On receipt of a COMMON CONTROL ACK message containing not the same control_function_id IE the IUT shall ignore the message.

On time-out of timer T02 the IUT shall repeat sending the COMMON CONTROL message.

5.2.6.2 V5NWKAN/CTRL/TI/PORT

5.2.6.2.1 V5NWKAN/CTRL/TI/PORT/TRANS

Refer to ETS 300 324-1 [1], tables 58 and 59, and figures L.11.1 to L.11.2.

Initial state of the IUT: CTRL_COM_INIT, CTRL_PORT_INIT
Preamble: CTRL_PSTN_LE20_10, CTRL_ISDNBA_LE20_10
Postamble: -

TP1621S2_01 Preamble:
On receipt of a PORT CONTROL message containing the control_function_element IE FE201 (unlock_req) the IUT shall send a PORT CONTROL ACK message containing the same control_function_element IE.

On receipt of a MPH_UBR (unlock_ack) the IUT shall send a PORT CONTROL message containing the control_function_element IE FE202 (unlock_ack). On time-out of timer T01 the IUT shall repeat sending the PORT CONTROL message N01 times.

TP1621S2_02 Preamble:
On receipt of a PORT CONTROL message containing the control_function_element IE FE201 (unlock_req) the IUT shall send a PORT CONTROL ACK message containing the same control_function_element IE.

On receipt of a MPH_UBR (unlock_ack) the IUT shall send a PORT CONTROL message containing the control_function_element IE FE202 (unlock_ack). On receipt of a PORT CONTROL ACK message containing not the same control_function_element IE the IUT shall ignore the message. On time-out of timer T01 the IUT shall repeat sending the PORT CONTROL message N01 times.

5.3 PSTN protocol

The preamble of any test always begins before with PSTN port blocking followed by PSTN port unblocking to be sure that delayed or outstanding messages are discarded.

NOTE: This test group is only valid if PICS M2 is set to "Yes" (see ETS 300 324-2 [2]).

5.3.1 Basic interconnection tests (V5NWKAN/PSTN/IT)

Refer to ETS 300 324-1 [1], table 29 and figures L.9.1 to L.9.11.

All messages sent by LT1 have to be valid PSTN messages.

Initial state of the IUT: CTRL_COM_INIT, CTRL_PORT_INIT, PSTN_INIT
Preamble: PSTN_ANx_6 & PSTN_AN6_1
Postamble: PSTN_ANx_6

TP21__S1_01 On receipt of a STATUS ENQUIRY message the IUT shall send a STATUS message.

5.3.2 Capability tests (V5NWKAN/PSTN/CA)

Refer to ETS 300 324-1 [1], table 29 and figures L.9.1 to L.9.11.

This test group is only valid if PSTN application is provisioned.

All messages sent by LT1 have to be valid PSTN messages.

Initial state of the IUT: CTRL_COM_INIT, CTRL_PORT_INIT, PSTN_INIT
Preamble: PSTN_ANx_6 & PSTN_AN6_1
Postamble: PSTN_ANx_6

TP22__SM_01 (*) On receipt of an originating call attempt (FE-subscriber_seizure) the IUT shall send the message ESTABLISH.

TP22__SM_02 On receipt of the ESTABLISH message the IUT shall send the message ESTABLISH ACK.
On receipt of a DISCONNECT message the IUT shall send a DISCONNECT COMPLETE message.

5.3.3 Valid behaviour tests (V5NWKAN/PSTN/BV)

Refer to ETS 300 324-1 [1], table 29 and figures L.9.1 to L.9.11.

All messages sent by LT1 and IUT have to be valid PSTN messages.

5.3.3.1 V5NWKAN/PSTN/BV/0

Initial state of the IUT: CTRL_COM_INIT, CTRL_PORT_INIT, PSTN_INIT
Preamble: PSTN_ANx_6 & PSTN_AN6_1 & AN1_0
Postamble: PSTN_ANx_6

TP23__S0_01 On receipt of a STATUS ENQUIRY message the IUT shall send a STATUS message containing the cause_type "response to status enquiry" and the state AN0 and remain in the PSTN_path_state AN0 (Out of Service).

TP23__S0_02 On receipt of a PORT CONTROL message containing the control_function_element IE FE203 (block_cmd) (the PSTN protocol entity receives the MDU-CTRL port_blocked) the IUT shall enter the PSTN_path_state AN6 (Port blocked).

TP23__S0_03 On receipt of a COMMON CONTROL message containing the control_function_id IE "restart req" (the PSTN protocol entity receives the MDU-CTRL restart_request) the IUT shall remain in the PSTN_path_state AN0 (Out of Service).

On receipt of a COMMON CONTROL message containing the control_function_id IE "restart complete" (MDU-CTRL restart_complete) the IUT shall enter the PSTN_path_state AN1 (Null) and check for the line condition.

TP23__S0_04 (*) On receipt of the event FE-subscriber_seizure, the IUT shall remain in the PSTN_path_state AN0 (Out of Service).

TP23__S0_05 (*) On receipt of the event FE-line_information, the IUT shall send the ESTABLISH message and enter the PSTN_path_state AN0 (Out of Service).

TP23__S0_06 (*) On receipt of the event FE-subscriber_release, the IUT shall remain in the PSTN_path_state AN0 (Out of Service).

TP23__S0_07 (*) On receipt of the event FE-line_signal, the IUT shall remain in the PSTN_path_state AN0 (Out of Service). Verify no messages on the V5 interface.

5.3.3.2 V5NWKAN/PSTN/BV/1

Initial state of the IUT: CTRL_COM_INIT, CTRL_PORT_INIT, PSTN_INIT
Preamble: PSTN_ANx_6 & PSTN_AN6_1
Postamble: PSTN_ANx_6

TP23__S1_01 On receipt of a STATUS ENQUIRY message the IUT shall send a STATUS message containing the cause_type "response to status enquiry" and the state AN1 and remain in the PSTN_path_state AN1 (Null).

TP23__S1_02 On receipt of an originating call attempt (FE-subscriber_seizure) the IUT shall send the message ESTABLISH and enter the PSTN_path_state AN2 (Path initiated by AN).
(*)

TP23__S1_03 On receipt of the ESTABLISH message the IUT shall send the message ESTABLISH ACK and enter the PSTN_path_state AN5 (Path active).

TP23__S1_04 On receipt of a PORT CONTROL message containing the control_function_element IE FE203 (block_cmd) (the PSTN protocol entity receives the MDU-CTRL port_blocked) the IUT shall send a DISCONNECT COMPLETE message and enter the PSTN_path_state AN6 (Port blocked).

The IUT shall stop all timers and no more messages shall be received from the user port.

TP23__S1_05 On receipt of a COMMON CONTROL message containing the control_function_id IE "restart req" (the PSTN protocol entity receives the MDU-CTRL restart_request) the IUT shall send a DISCONNECT COMPLETE message followed by a COMMON CONTROL message containing the control_function_id IE "restart_complete" and enter in the PSTN_path_state AN0 (Out of Service).

On receipt of a COMMON CONTROL message containing the control_function_id IE "restart complete" (MDU-CTRL restart_complete) the IUT shall enter the PSTN_path_state AN1 (Null) and check for the line condition.

TP23__S1_06 On receipt of DISCONNECT message the IUT shall send the message DISCONNECT COMPLETE and remain the same PSTN_path_state AN1 (Null).

TP23__S1_07 On receipt of the event FE-line_information, the IUT shall send the ESTABLISH message and enter the PSTN_path_state AN4 (Line information).
(*)

TP23__S1_08 On receipt of the event FE-line_signal, the IUT shall remain in the PSTN_path_state AN1 (Null).
(*)

Verify no messages on the V5 interface.

TP23__S1_09 On receipt of the event FE-subscriber_release, the IUT shall remain in the PSTN_path_state AN1 (Null).
(*)

Verify no messages on the V5 interface.

TP23__S1_10 On receipt of DISCONNECT COMPLETE message the IUT shall remain in the PSTN_path_state AN1 (Null).

TP23__S1_11 On receipt of a PORT CONTROL message containing the control_function_element IE FE201 (unblock_req) (the PSTN protocol entity receives the MDU-CTRL port_unblocked) the IUT shall remain in the PSTN_path_state AN1 (Null).

5.3.3.3 V5NWKAN/PSTN/BV/2

Initial state of the IUT: CTRL_COM_INIT, CTRL_PORT_INIT, PSTN_INIT
Precondition: PSTN_AN1_2
Preamble: PSTN_ANx_6 & PSTN_AN6_1
Postamble: PSTN_ANx_6

TP23__S2_01 (*) On receipt of an ESTABLISH message, the IUT shall send an ESTABLISH ACK message and enter the PSTN_path_state AN5 (Path active) (if terminating calls have priority).

The IUT shall stop timer T1/T2 and not repeat the message ESTABLISH.

TP23__S2_02 (*) On receipt of an ESTABLISH message, the IUT shall remain in the PSTN_path_state AN2 (Path initiated by AN) (if originating calls have priority).

TP23__S2_03 (*) On receipt of a FE-subscriber_release, the IUT shall enter the PSTN_path_state AN3 (Path abort request).

TP23__S2_04 (*) On receipt of the ESTABLISH ACK message the IUT shall enter the PSTN_path_state AN5 (Path active).

The IUT shall stop timer T1/T2 and not repeat the message ESTABLISH.

TP23__S2_05 (*) On receipt of a DISCONNECT message, the IUT shall send a DISCONNECT COMPLETE message and enter the PSTN_path_state AN1 (Null).

Since the subscriber seizure condition is still present, the IUT shall send an ESTABLISH message and enter the PSTN_path_state AN2.

TP23__S2_06 (*) On receipt of a DISCONNECT COMPLETE message, the IUT shall enter the PSTN_path_state AN1 (Null).

Since the subscriber seizure condition is still present, the IUT shall send an ESTABLISH message and enter the PSTN_path_state AN2.

TP23__S2_07 (*) On receipt of a STATUS ENQUIRY message the IUT shall send a STATUS message containing the cause_type "response to status enquiry" and the state AN2 and remain in the PSTN_path_state AN2 (Path initiated by AN).

TP23__S2_08 (*) On receipt of a COMMON CONTROL message containing the control_function_id IE "restart req", the IUT shall send a DISCONNECT COMPLETE message and a COMMON CONTROL message containing the control_function_id IE "restart complete". The IUT shall enter the PSTN_path_state AN0 (Out of Service).

On receipt of a COMMON CONTROL message containing the control_function_id IE "restart complete" (MDU-CTRL restart_complete) the IUT shall enter the PSTN_path_state AN1 (Null) and check for the line condition.

Since the subscriber seizure condition is still present, the IUT shall send an ESTABLISH message and enter the PSTN_path_state AN2.

TP23__S2_09 (*) On receipt of a PORT CONTROL message containing the control_function_element IE FE203 (block_cmd) (the PSTN protocol entity receives the MDU-CTRL port_blocked) the IUT shall send a DISCONNECT COMPLETE message and enter the PSTN_path_state AN6 (Port blocked).

The IUT shall stop all timers and no more messages shall be received from the user port.

- TP23__S2_10 (*) On receipt of the event FE-line_signal, the IUT shall remain in the PSTN_path_state AN2 (Path initiated by AN).
- TP23__S2_11 (*) On receipt of a PORT CONTROL message containing the control_function_element IE FE201 (unblock_req) (the PSTN protocol entity receives the MDU-CTRL port_unblocked) the IUT shall remain in the PSTN_path_state AN2 (Path initiated by AN).

5.3.3.4 V5NWKAN/PSTN/BV/3

Initial state of the IUT: CTRL_COM_INIT, CTRL_PORT_INIT, PSTN_INIT

Precondition: PSTN_AN1_2 & PSTN_AN2_3

Preamble: PSTN_ANx_6 & PSTN_AN6_1

Postamble: PSTN_ANx_6

- TP23__S3_01 (*) On receipt of an ESTABLISH ACK message, the IUT shall send a DISCONNECT message and enter the PSTN_path_state AN7 (Disconnect request).

The IUT shall stop timer T1/T2 and not repeat the message ESTABLISH.

- TP23__S3_02 (*) On receipt of a FE-subscriber_seizure, the IUT shall enter the PSTN_path_state AN2 (Path initiated by AN).

- TP23__S3_03 (*) On receipt of an ESTABLISH message, the IUT shall send an ESTABLISH ACK message and enter the PSTN_path_state AN5 (Path active) (if terminating calls have priority).

The IUT shall stop timer T1/T2 and not repeat the message ESTABLISH.

- TP23__S3_04 (*) On receipt of an ESTABLISH message, the IUT shall remain in the PSTN_path_state AN2 (Path initiated by AN) (if originating calls have priority).

- TP23__S3_05 (*) On receipt of a DISCONNECT message, the IUT shall send a DISCONNECT COMPLETE message and enter the PSTN_path_state AN1 (Null).

- TP23__S3_06 (*) On receipt of a DISCONNECT COMPLETE message, the IUT shall enter the PSTN_path_state AN1 (Null).

- TP23__S3_07 (*) On receipt of a STATUS ENQUIRY message the IUT shall send a STATUS message containing the cause_type "response to status enquiry" and the state AN3 and remain in the PSTN_path_state AN3 (Path abort request).

- TP23__S3_08 (*) On receipt of a COMMON CONTROL message containing the control_function_id IE "restart req", the IUT shall send a DISCONNECT COMPLETE message and a COMMON CONTROL message containing the control_function_id IE "restart complete". The IUT shall enter the PSTN_path_state AN0 (Out of Service).

On receipt of a COMMON CONTROL message containing the control_function_id IE "restart complete" (MDU-CTRL restart_complete) the IUT shall enter the PSTN_path_state AN1 (Null).

- TP23__S3_09 (*) On receipt of a PORT CONTROL message containing the control_function_element IE FE203 (block_cmd) (the PSTN protocol entity receives the MDU-CTRL port_blocked) the IUT shall send a DISCONNECT COMPLETE message and enter the PSTN_path_state AN6 (Port blocked).

The IUT shall stop all timers and no more messages shall be received from the user port.

- TP23__S3_10 (*) On receipt of the event FE-line_signal, the IUT shall remain in the PSTN_path_state AN3 (Path abort request).
- Check that no further event occurs on the V5 interface.
- TP23__S3_11 On receipt of a PORT CONTROL message containing the control_function_element IE FE201 (unblock_req) (the PSTN protocol entity receives the MDU-CTRL port_unblocked) the IUT shall remain in the PSTN_path_state AN3 (Path abort request).

5.3.3.5 V5NWKAN/PSTN/BV/4

Initial state of the IUT: CTRL_COM_INIT, CTRL_PORT_INIT, PSTN_INIT
Preamble: PSTN_ANx_6 & PSTN_AN6_1 & PSTN_AN1_4
Postamble: PSTN_ANx_6

- TP23__S4_01 On receipt of a DISCONNECT message, the IUT shall send a DISCONNECT COMPLETE message and enter the PSTN_path_state AN1 (Null).
- TP23__S4_02 On receipt of a DISCONNECT COMPLETE message, the IUT shall enter the PSTN_path_state AN1 (Null).
- TP23__S4_03 On receipt of a STATUS ENQUIRY message the IUT shall send a STATUS message containing the cause_type "response to status enquiry" and the state AN4 and remain in the PSTN_path_state AN4 (Line information).
- TP23__S4_04 On receipt of a COMMON CONTROL message containing the control_function_id IE "restart req", the IUT shall send a DISCONNECT COMPLETE message and a COMMON CONTROL message containing the control_function_id IE "restart complete". The IUT shall enter the PSTN_path_state AN0 (Out of Service).
- On receipt of a COMMON CONTROL message containing the control_function_id IE "restart complete" (MDU-CTRL restart_complete) the IUT shall enter the PSTN_path_state AN1 (Null).
- TP23__S4_05 On receipt of a PORT CONTROL message containing the control_function_element IE FE203 (block_cmd) (the PSTN protocol entity receives the MDU-CTRL port_blocked) the IUT shall send a DISCONNECT COMPLETE message and enter the PSTN_path_state AN6 (Port blocked).
- The IUT shall stop all timers and no more messages shall be received from the user port.
- TP23__S4_06 (*) On receipt of the event FE-subscriber_release, the IUT shall remain in the PSTN_path_state AN4 (Line information).
- TP23__S4_07 (*) On receipt of an ESTABLISH message, the IUT shall remain in the PSTN_path_state AN4 (Line information).
- TP23__S4_08 (*) On receipt of the event FE-subscriber_seizure, the IUT shall remain in the PSTN_path_state AN4 (Line information).
- TP23__S4_09 (*) On receipt of the event FE-line_signal, the IUT shall remain in the PSTN_path_state AN4 (Line information).
- Check that no further event occurs on the V5 interface.
- TP23__S4_10 On receipt of a PORT CONTROL message containing the control_function_element IE FE201 (unblock_req) (the PSTN protocol entity receives the MDU-CTRL port_unblocked) the IUT shall remain in the PSTN_path_state AN4 (Line information).

5.3.3.6 V5NWKAN/PSTN/BV/5

Initial state of the IUT: CTRL_COM_INIT, CTRL_PORT_INIT, PSTN_INIT
Preamble: PSTN_ANx_6 & PSTN_AN6_1 & PSTN_AN1_5
Postamble: PSTN_ANx_6

TP23__S5_01 On receipt of a DISCONNECT message, the IUT shall send a DISCONNECT COMPLETE message and enter the PSTN_path_state AN1 (Null).

TP23__S5_02 On receipt of a DISCONNECT COMPLETE message, the IUT shall enter the PSTN_path_state AN1 (Null).

TP23__S5_03 On receipt of a line condition (digits) (FE-line_signal), the IUT shall send a SIGNAL (*) message containing the line condition and remain in the PSTN_path_state AN5 (Path active). On receipt of a SIGNAL ACK message containing the correct sequence number IE the IUT shall remain in the PSTN_path_state AN5 (Path active).

On receipt of two subsequent line conditions (digits) (FE-line_signal), the IUT shall send two SIGNAL messages containing the line conditions and remain in the PSTN_path_state AN5 (Path active). On receipt of a SIGNAL ACK message containing the correct sequence number IE the IUT shall remain in the PSTN_path_state AN5 (Path active).

TP23__S5_04 On receipt of a SIGNAL message, the IUT shall generate line conditions to the line stated in the SIGNAL message and remain in the PSTN_path_state AN5. On time-out of Tr the IUT shall send a SIGNAL ACK message and remain in the PSTN_path_state AN5 (Path active).

On receipt of two subsequent SIGNAL messages, the IUT shall generate line conditions to the line stated in the SIGNAL messages and remain in the PSTN_path_state AN5. On time-out of Tr the IUT shall send a SIGNAL ACK message and remain in the PSTN_path_state AN5 (Path active).

TP23__S5_05 On receipt of a STATUS ENQUIRY message the IUT shall send a STATUS message containing the cause_type "response to status enquiry" and the state AN5 and remain in the PSTN_path_state AN5 (Path active).

TP23__S5_06 On receipt of a COMMON CONTROL message containing the control_function_id IE "restart req", the IUT shall send a DISCONNECT COMPLETE message and a COMMON CONTROL message containing the control_function_id IE "restart complete". The IUT shall enter the PSTN_path_state AN0 (Out of Service).

On receipt of a COMMON CONTROL message containing the control_function_id IE "restart complete" (MDU-CTRL restart_complete) the IUT shall enter the PSTN_path_state AN1 (Null).

TP23__S5_07 On receipt of a PORT CONTROL message containing the control_function_element IE FE203 (block_cmd) (the PSTN protocol entity receives the MDU-CTRL port_blocked) the IUT shall send a DISCONNECT COMPLETE message and enter the PSTN_path_state AN6 (Port blocked).

The IUT shall stop all timers and no more messages shall be received from the user port.

TP23__S5_08 On receipt of a PROTOCOL PARAMETER message, the IUT shall remain in the PSTN_path_state AN5 (Path active). On time-out of Tr the IUT shall send a SIGNAL ACK message and remain in the PSTN_path_state AN5 (Path active).

TP23__S5_09 On receipt of a PORT CONTROL message containing the control_function_element IE FE201 (unblock_req) (the PSTN protocol entity receives the MDU-CTRL port_unblocked) the IUT shall remain in the PSTN_path_state AN5 (Path active).

5.3.3.7 V5NWKAN/PSTN/BV/6

Initial state of the IUT: CTRL_COM_INIT, CTRL_PORT_INIT, PSTN_INIT
Preamble: PSTN_ANx_6
Postamble: PSTN_ANx_6

TP23__S6_01 On receipt of a COMMON CONTROL message containing the control_function_id IE "restart req" the IUT shall send a COMMON CONTROL message containing the control_function_id IE "restart complete" and remain in the PSTN_path_state AN6 (Port blocked).

Postamble this test purpose by sending a COMMON CONTROL message containing the control_function_id IE "restart complete".

TP23__S6_02 On receipt of a STATUS ENQUIRY message the IUT shall send a STATUS message containing the cause_type "response to status enquiry" and the state AN6 and remain in the PSTN_path_state AN6 (Port blocked).

TP23__S6_03 On receipt of a PORT CONTROL message containing the control_function_element IE FE203 (block_cmd) (the PSTN protocol entity receives the MDU-CTRL port_blocked) the IUT shall remain in the PSTN_path_state AN6 (Port blocked).

The IUT shall stop all timers and no more messages shall be received from the user port.

TP23__S6_04 On receipt of the event FE-subscriber_seizure, the IUT shall remain in the PSTN_path_state AN6 (Port blocked).
(*)

TP23__S6_05 On receipt of the event FE-line_signal, the IUT shall remain in the PSTN_path_state AN6 (Port blocked).
(*)

Check that no further event occurs on the V5 interface.

TP23__S6_06 On receipt of the event FE-subscriber_release, the IUT shall remain in the PSTN_path_state AN6 (Port blocked).
(*)

TP23__S6_07 On receipt of a PORT CONTROL message containing the control_function_element IE FE201 (unblock_req) (the PSTN protocol entity receives the MDU-CTRL port_unblocked) the IUT shall enter the PSTN_path_state AN1 (Null).

5.3.3.8 V5NWKAN/PSTN/BV/7

Initial state of the IUT: CTRL_COM_INIT, CTRL_PORT_INIT, PSTN_INIT
Preamble: PSTN_ANx_6 & PSTN_AN6_1 & PSTN_AN1_5 & PSTN_AN5_7
Postamble: PSTN_ANx_6

TP23__S7_01 On receipt of a DISCONNECT message containing a signal IE, the IUT shall enter the PSTN_path_state AN1 (Null).

TP23__S7_02 On receipt of a DISCONNECT COMPLETE message, the IUT shall enter the PSTN_path_state AN1 (Null).

TP23__S7_03 On receipt of a STATUS ENQUIRY message the IUT shall send a STATUS message containing the cause_type "response to status enquiry" and the state AN7 and remain in the PSTN_path_state AN7 (Disconnect request).

- TP23__S7_04 On receipt of a COMMON CONTROL message containing the control_function_id IE "restart req", the IUT shall send a DISCONNECT COMPLETE message and a COMMON CONTROL message containing the control_function_id IE "restart complete" (PSTN FSM sends MDU restart_ack). The IUT shall enter the PSTN_path_state AN0 (Out of Service).
- On receipt of a COMMON CONTROL message containing the control_function_id IE "restart complete" (MDU-CTRL restart_complete) the IUT shall enter the PSTN_path_state AN1 (Null).
- TP23__S7_05 On receipt of a PORT CONTROL message containing the control_function_element IE FE203 (block_cmd) (the PSTN protocol entity receives the MDU-CTRL port_blocked) the IUT shall send a DISCONNECT COMPLETE message and enter the PSTN_path_state AN6 (Port blocked).
- The IUT shall stop all timers and no more messages shall be received from the user port.
- TP23__S7_06 On receipt of an ESTABLISH message the IUT shall remain in the PSTN_path_state AN7 (Disconnect Request).
- TP23__S7_07 On receipt of an ESTABLISH ACK message the IUT shall remain in the PSTN_path_state AN7 (Disconnect Request).
- TP23__S7_08 On receipt of a SIGNAL message the IUT shall remain in the PSTN_path_state AN7 (Disconnect Request).
- TP23__S7_09 On receipt of a SIGNAL ACK message the IUT shall remain in the PSTN_path_state AN7 (Disconnect Request).
- TP23__S7_10 On receipt of a PORT CONTROL message containing the control_function_element IE FE201 (unblock_req) (the PSTN protocol entity receives the MDU-CTRL port_unblocked) the IUT shall remain in the PSTN_path_state AN7 (Disconnect Request).
- TP23__S7_11
(*) On receipt of the event FE-subscriber_seizure, the IUT shall remain in the PSTN_path_state AN7 (Disconnect Request).
- Check that no further event occurs on the V5 interface.
- TP23__S7_12
(*) On receipt of the event FE-line_signal, the IUT shall remain in the PSTN_path_state AN7 (Disconnect Request).
- TP23__S7_13
(*) On receipt of the event FE-subscriber_release, the IUT shall remain in the PSTN_path_state AN7 (Disconnect Request).
- Check that no further event occurs on the V5 interface.

5.3.4 Inopportune behaviour tests (V5NWKAN/PSTN/BO)

Refer to ETS 300 324-1 [1], table 29 and subclause L.1.4.

All messages sent by LT1 and IUT have to be valid PSTN messages.

5.3.4.1 V5NWKAN/PSTN/BO/0

Initial state of the IUT: CTRL_COM_INIT, CTRL_PORT_INIT, PSTN_INIT
Preamble: PSTN_ANx_6 & PSTN_AN6_0
Postamble: PSTN_ANx_6

TP24__S0_01 (*) On receipt of an ESTABLISH ACK message the IUT shall send a STATUS message containing the cause_type "message not compatible with path state", the ESTABLISH ACK message type identifier and the state AN0. The IUT shall remain in the PSTN_path_state AN0 (Out of service).

TP24__S0_02 (*) On receipt of an ESTABLISH message the IUT shall send a STATUS message containing the cause_type "message not compatible with path state", the ESTABLISH message type identifier and the state AN0. The IUT shall remain in the PSTN_path_state AN0 (Out of service).

TP24__S0_03 (*) On receipt of an DISCONNECT message the IUT shall send a STATUS message containing the cause_type "message not compatible with path state", the DISCONNECT message type identifier and the state AN0. The IUT shall remain in the PSTN_path_state AN0 (Out of service).

TP24__S0_04 (*) On receipt of an SIGNAL message the IUT shall send a STATUS message containing the cause_type "message not compatible with path state", the SIGNAL message type identifier and the state AN0. The IUT shall remain in the PSTN_path_state AN0 (Out of service).

TP24__S0_05 (*) On receipt of an DISCONNECT COMPLETE message the IUT shall send a STATUS message containing the cause_type "message not compatible with path state", the DISCONNECT COMPLETE message type identifier and the state AN0. The IUT shall remain in the PSTN_path_state AN0 (Out of service).

TP24__S0_06 (*) On receipt of an PROTOCOL PARAMETER message the IUT shall send a STATUS message containing the cause_type "message not compatible with path state", the PROTOCOL PARAMETER message type identifier and the state AN0. The IUT shall remain in the PSTN_path_state AN0 (Out of service).

TP24__S0_07 (*) On receipt of an SIGNAL ACK message the IUT shall send a STATUS message containing the cause_type "message not compatible with path state", the SIGNAL ACK message type identifier and the state AN0 (Out of service). The IUT shall remain in the PSTN_path_state AN0 (Out of service).

TP24__S0_08 (*) On receipt of a PORT CONTROL message containing the control_function_element IE FE201 (unblock_req) (the PSTN protocol entity receives the MDU-CTRL port_unblocked) the IUT shall remain in the PSTN_path_state AN0 (Out of service).

5.3.4.2 V5NWKAN/PSTN/BO/1

Initial state of the IUT: CTRL_COM_INIT, CTRL_PORT_INIT, PSTN_INIT
Preamble: PSTN_ANx_6 & PSTN_AN6_1
Postamble: PSTN_ANx_6

TP24__S1_01 On receipt of an ESTABLISH ACK message the IUT shall send a STATUS message containing the cause_type "message not compatible with path state", the ESTABLISH ACK message type identifier and the state AN1. The IUT shall remain in the PSTN_path_state AN1 (Null).

- TP24__S1_02 On receipt of an SIGNAL message the IUT shall send a STATUS message containing the cause_type "message not compatible with path state", the SIGNAL message type identifier and the state AN1. The IUT shall remain in the PSTN_path_state AN1 (Null).
- TP24__S1_03 On receipt of an PROTOCOL PARAMETER message the IUT shall send a STATUS message containing the cause_type "message not compatible with path state", the PROTOCOL PARAMETER message type identifier and the state AN1. The IUT shall remain in the PSTN_path_state AN1 (Null).
- TP24__S1_04 On receipt of an SIGNAL ACK message the IUT shall send a STATUS message containing the cause_type "message not compatible with path state", the SIGNAL ACK message type identifier and the state AN1. The IUT shall remain in the PSTN_path_state AN1 (Null).

5.3.4.3 V5NWKAN/PSTN/BO/2

Initial state of the IUT: CTRL_COM_INIT, CTRL_PORT_INIT, PSTN_INIT
Precondition: PSTN_AN1_2
Preamble: PSTN_ANx_6 & PSTN_AN6_1
Postamble: PSTN_ANx_6

- TP24__S2_01 On receipt of a SIGNAL message the IUT shall send a STATUS message containing the cause_type "message not compatible with path state", the SIGNAL message type identifier and the state AN2 The IUT shall remain in the PSTN_path_state AN2 (Path initiated by AN).
(*)
- TP24__S2_02 On receipt of a SIGNAL ACK message the IUT shall send a STATUS message containing the cause_type "message not compatible with path state", the SIGNAL ACK message type identifier and the state AN2 The IUT shall remain in the PSTN_path_state AN2 (Path initiated by AN).
(*)
- TP24__S2_03 Unexpected subscriber seizure:
(*)

On receipt of the event FE-subscriber_seizure, the IUT shall remain in the PSTN_path_state AN2 (Path initiated by AN).
- TP24__S2_04 Unexpected line information:
(*)

On receipt of the event FE-line_information, the IUT shall remain in the PSTN_path_state AN2 (Path initiated by AN).

5.3.4.4 V5NWKAN/PSTN/BO/3

Initial state of the IUT: CTRL_COM_INIT, CTRL_PORT_INIT, PSTN_INIT
Precondition: PSTN_AN1_2
Preamble: PSTN_ANx_6 & PSTN_AN6_1 & PSTN_AN2_3
Postamble: PSTN_ANx_6

- TP24__S3_01 On receipt of a SIGNAL message the IUT shall send a STATUS message containing the cause_type "message not compatible with path state", the SIGNAL message type identifier and the state AN3 The IUT shall remain in the PSTN_path_state AN3 (Path abort request).
(*)
- TP24__S3_02 On receipt of a SIGNAL ACK message the IUT shall send a STATUS message containing the cause_type "message not compatible with path state", the SIGNAL ACK message type identifier and the state AN3 The IUT shall remain in the PSTN_path_state AN3 (Path abort request).
(*)
- TP24__S3_03 On receipt of a PROTOCOL PARAMETER message the IUT shall send a STATUS message containing the cause_type "message not compatible with path state", the PROTOCOL PARAMETER message type identifier and the state AN3 The IUT shall remain in the PSTN_path_state AN3 (Path abort request).
(*)

TP24__S3_04 Unexpected line information:
(*)
On receipt of the event FE-line_information, the IUT shall remain in the PSTN_path_state AN3 (Path abort request).

TP24__S3_05 Unexpected subscriber release:
(*)
On receipt of the event FE-subscriber_release, the IUT shall remain in the PSTN_path_state AN3 (Path abort request).

5.3.4.5 V5NWKAN/PSTN/BO/4

Initial state of the IUT: CTRL_COM_INIT, CTRL_PORT_INIT, PSTN_INIT
Preamble: PSTN_ANx_6 & PSTN_AN6_1 & PSTN_AN1_4
Postamble: PSTN_ANx_6

TP24__S4_01 On receipt of a SIGNAL message the IUT shall send a STATUS message containing the cause_type "message not compatible with path state", the SIGNAL message type identifier and the state AN4 The IUT shall remain in the PSTN_path_state AN4 (Line information).

TP24__S4_02 On receipt of a SIGNAL ACK message the IUT shall send a STATUS message containing the cause_type "message not compatible with path state", the SIGNAL ACK message type identifier and the state AN4 The IUT shall remain in the PSTN_path_state AN4 (Line information).

TP24__S4_03 On receipt of a PROTOCOL PARAMETER message the IUT shall send a STATUS message containing the cause_type "message not compatible with path state", the PROTOCOL PARAMETER message type identifier and the state AN4 The IUT shall remain in the PSTN_path_state AN4 (Line information).

TP24__S4_04 On receipt of an ESTABLISH ACK message the IUT shall send a STATUS message containing the cause_type "message not compatible with path state", the ESTABLISH ACK message type identifier and the state AN4 The IUT shall remain in the PSTN_path_state AN4 (Line information).

TP24__S4_05 Unexpected line information:

On receipt of the event FE-line_information, the IUT shall remain in the PSTN_path_state AN4 (Line information).

5.3.4.6 V5NWKAN/PSTN/BO/5

Initial state of the IUT: CTRL_COM_INIT, CTRL_PORT_INIT, PSTN_INIT
Preamble: PSTN_ANx_6 & PSTN_AN6_1 & PSTN_AN1_5
Postamble: PSTN_ANx_6

TP24__S5_01 On receipt of an ESTABLISH message the IUT shall send a STATUS message containing the cause_type "message not compatible with path state", the ESTABLISH message type identifier and the state AN5 The IUT shall remain in the PSTN_path_state AN5 (Path active).

TP24__S5_02 On receipt of an ESTABLISH ACK message the IUT shall send a STATUS message containing the cause_type "message not compatible with path state", the ESTABLISH ACK message type identifier and the state AN5 The IUT shall remain in the PSTN_path_state AN5 (Path active).

TP24__S5_03 -

- TP24__S5_04 Unexpected subscriber seizure:
(*)
On receipt of the event FE-subscriber_seizure, the IUT shall remain in the PSTN_path_state AN5 (Path active).
- TP24__S5_05 Unexpected line information:
(*)
On receipt of the event FE-line_information, the IUT shall remain in the PSTN_path_state AN5 (Path active).
- TP24__S5_06 Unexpected subscriber release:
(*)
On receipt of the event FE-subscriber_release, the IUT shall remain in the PSTN_path_state AN5 (Path active).

5.3.4.7 V5NWKAN/PSTN/BO/6

Initial state of the IUT: CTRL_COM_INIT, CTRL_PORT_INIT, PSTN_INIT
Preamble: PSTN_ANx_6
Postamble: PSTN_ANx_6

- TP24__S6_01 On receipt of an ESTABLISH message the IUT shall send a STATUS message containing the cause_type "message not compatible with path state", the ESTABLISH message type identifier and the state AN6. The IUT shall remain in the PSTN_path_state AN6 (Port blocked).
- TP24__S6_02 On receipt of an ESTABLISH ACK message the IUT shall send a STATUS message containing the cause_type "message not compatible with path state", the ESTABLISH ACK message type identifier and the state AN6. The IUT shall remain in the PSTN_path_state AN6 (Port blocked).
- TP24__S6_03 On receipt of a SIGNAL message the IUT shall send a STATUS message containing the cause_type "message not compatible with path state", the SIGNAL message type identifier and the state AN6. The IUT shall remain in the PSTN_path_state AN6 (Port blocked).
- TP24__S6_04 On receipt of a SIGNAL ACK message the IUT shall send a STATUS message containing the cause_type "message not compatible with path state", the SIGNAL ACK message type identifier and the state AN6. The IUT shall remain in the PSTN_path_state AN6 (Port blocked).
- TP24__S6_05 On receipt of a DISCONNECT message the IUT shall send a STATUS message containing the cause_type "message not compatible with path state", the DISCONNECT message type identifier and the state AN6. The IUT shall remain in the PSTN_path_state AN6 (Port blocked).
- TP24__S6_06 On receipt of a DISCONNECT COMPLETE message the IUT shall send a STATUS message containing the cause_type "message not compatible with path state", the DISCONNECT COMPLETE message type identifier and the state AN6. The IUT shall remain in the PSTN_path_state AN6 (Port blocked).
- TP24__S6_07 On receipt of a PROTOCOL PARAMETER message the IUT shall remain in the PSTN_path_state AN6 (Port blocked).

5.3.4.8 V5NWKAN/PSTN/BO/7

Initial state of the IUT: CTRL_COM_INIT, CTRL_PORT_INIT, PSTN_INIT
Preamble: PSTN_ANx_6 & PSTN_AN6_1 & PSTN_AN1_5 & PSTN_AN5_7
Postamble: PSTN_ANx_6

TP24__S7_01 On receipt of a PROTOCOL PARAMETER message the IUT shall remain in the PSTN_path_state AN7 (Disconnect request).

TP24__S7_02 Unexpected line information:
(*)
On receipt of the event FE-line_information, the IUT shall remain in the PSTN_path_state AN7 (Disconnect request).

5.3.5 Invalid behaviour tests (V5NWKAN/PSTN/BI)

Refer to ETS 300 324-1 [1], subclause 13.5.2.

5.3.5.1 V5NWKAN/PSTN/BI/1

Initial state of the IUT: CTRL_COM_INIT, CTRL_PORT_INIT, PSTN_INIT
Preamble: PSTN_ANx_6 & PSTN_AN6_1
Postamble: PSTN_ANx_6

TP25__S1_01 Check that the IUT discards messages containing less than 4 octets and remains in the PSTN_path_state AN1 (Null).

TP25__S1_02 (protocol discriminator error)
Check that the IUT discards an ESTABLISH message (sends no ESTABLISH ACK message) containing an unspecified protocol_discriminator IE. The IUT shall send a STATUS message containing the cause_type "protocol discriminator error" (edition 1).

TP25__S1_03 (L3 address error)
Check that the IUT discards an ESTABLISH message (sends no ESTABLISH ACK message) containing an unprovisioned L3addr. The IUT shall send a STATUS message containing the cause_type "L3 address error" and the state AN1. The IUT shall remain in the PSTN_path_state AN1 (Null).
The STATUS message sent by the AN shall contain the state IE "not applicable" and not "AN1" (refer to ETS 300 324-1 [1], subclause 13.5.2.2).

TP25__S1_04 (message type error)
Check that the IUT discards a message containing an unspecified message_type IE. The IUT shall send a STATUS message containing the cause_type "message type unrecognized", the received message type identifier and the state AN1. The IUT shall remain in the PSTN_path_state AN1 (Null).

TP25__S1_05 (repeated optional IEs)
On receipt of an ESTABLISH message containing more than 3 repeated valid optional IE the IUT shall send a STATUS message containing the cause_type "repeated optional IEs", the ESTABLISH message identifier, the repeated IE identifier and the state AN1. The IUT shall then send an ESTABLISH ACK message and enter the PSTN_path_state AN5 (Path active).

TP25__S1_06 (unrecognized IE)

On receipt of an ESTABLISH message containing one valid and one unspecified optional IE the IUT shall send a STATUS message containing the cause_type "unrecognized IE", the ESTABLISH message identifier, the unrecognized IE identifier and the state AN1. The IUT shall then send an ESTABLISH ACK message and enter the PSTN_path_state AN5 (Path active).

TP25__S1_07 (content error of optional IE)

On receipt of an ESTABLISH message containing one valid IE and one incorrect IE the IUT shall send a STATUS message containing the cause_type "optional IE content error", the ESTABLISH message identifier, the faulty IE identifier and the state AN1. The IUT shall then send an ESTABLISH ACK message and enter the PSTN_path_state AN5 (Path active).

TP25__S1_08 (optional IE not allowed)

Check that the IUT discards an ESTABLISH message (sends no ESTABLISH ACK message) containing two different valid IEs. The IUT shall send a STATUS message containing the cause_type "too many IEs", the ESTABLISH message identifier and the state AN1. The IUT shall remain in the PSTN_path_state AN1 (Null).

5.3.5.2 V5NWKAN/PSTN/BI/5

Initial state of the IUT: CTRL_COM_INIT, CTRL_PORT_INIT, PSTN_INIT
Preamble: PSTN_ANx_6 & PSTN_AN6_1 & PSTN_AN1_5
Postamble: PSTN_ANx_6

TP25__S5_01 (IE out of sequence)

Check that the IUT discards a SIGNAL message (sends no SIGNAL ACK message) containing a valid optional IE and the correct sequence_number IE out of sequence. The IUT shall send a STATUS message containing the cause_type "out of sequence IE", the SIGNAL message identifier, the faulty IE identifier and the state AN5. The IUT shall remain in the PSTN_path_state AN5 (Path Active).

TP25__S5_02 (repeated mandatory IEs)

Check that the IUT discards a SIGNAL ACK message containing two repeated sequence number IEs. The IUT shall send a STATUS message containing the cause_type "repeated mandatory IE", the SIGNAL message identifier, the repeated IE identifier and the state AN5. The IUT shall remain in the PSTN_path_state AN5 (Path Active).

TP25__S5_03 (mandatory IE missing)

Check that the IUT discards a SIGNAL message (sends no SIGNAL ACK message) containing no sequence_number IE. The IUT shall send a STATUS message containing the cause_type "mandatory IE missing", the SIGNAL message identifier, the missing IE identifier and the state AN5. The IUT shall remain in the PSTN_path_state AN5 (Path Active).

TP25__S5_04 (content error of mandatory IE)

On receipt of an SIGNAL message containing an invalid length of the mandatory IE "sequence_number" the IUT shall send a STATUS message containing the cause_type "Mandatory IE content error", the SIGNAL message identifier, the missing IE identifier and the state AN5. The IUT shall remain in the PSTN_path_state AN5 (Path active).

TP25__S5_05 (optional IE missing)

Check that the IUT discards a SIGNAL message (sends no SIGNAL ACK message) containing no optional IE. The IUT shall send a STATUS message containing the cause_type "mandatory IE missing ", the SIGNAL message identifier and the state AN5. The IUT shall remain in the PSTN_path_state AN5 (Path Active).

5.3.6 Timer expiry and counter mismatch tests (V5NWKAN/PSTN/TI)

Refer to ETS 300 324-1 [1], table 29 and subclause L.1.4.

5.3.6.1 V5NWKAN/PSTN/TI/2

Initial state of the IUT: CTRL_COM_INIT, CTRL_PORT_INIT, PSTN_INIT
Preamble: PSTN_ANx_6 & PSTN_AN6_1 & PSTN_AN1_2
Postamble: PSTN_ANx_6

TP26__S2_01 (*) On time-out of timer T1 the IUT shall repeat sending the ESTABLISH message and remain in the PSTN_path_state AN2 (Path initiated by AN). On receipt of an ESTABLISH ACK message after N1 repetitions of the ESTABLISH message the IUT shall enter the PSTN_path_state AN5 (Path active).

TP26__S2_02 (*) On time-out of timer T1 the IUT shall repeat sending the ESTABLISH message and remain in the PSTN_path_state AN2 (Path initiated by AN). On time-out of timer T2 the IUT shall repeat sending the ESTABLISH message and remain in the PSTN_path_state AN2 (Path initiated by AN). On receipt of an ESTABLISH ACK message after N2 repetitions of the ESTABLISH message the IUT shall enter the PSTN_path_state AN5 (Path active).

5.3.6.2 V5NWKAN/PSTN/TI/3

Initial state of the IUT: CTRL_COM_INIT, CTRL_PORT_INIT, PSTN_INIT
Preamble: PSTN_ANx_6 & PSTN_AN6_1 & PSTN_AN1_2 & PSTN_AN2_3
Postamble: PSTN_ANx_6

TP26__S3_01 (*) On time-out of timer T1 the IUT shall enter the PSTN_path_state AN1 (Null).

5.3.6.3 V5NWKAN/PSTN/TI/4

Initial state of the IUT: CTRL_COM_INIT, CTRL_PORT_INIT, PSTN_INIT
Preamble: PSTN_ANx_6 & PSTN_AN6_1 & PSTN_AN1_4
Postamble: PSTN_ANx_6

TP26__S4_01 (*) On time-out of timer T1 the IUT shall repeat sending the ESTABLISH message and remain in the PSTN_path_state AN4 (Line information). On receipt of a DISCONNECT COMPLETE message after N1 repetitions of the ESTABLISH message the IUT shall enter the PSTN_path_state AN1 (Null).

TP26__S4_02 (*) On time-out of timer T1 the IUT shall repeat sending the ESTABLISH message and remain in the PSTN_path_state AN4 (Line information). On time-out of timer T2 the IUT shall repeat sending the ESTABLISH message and remain in the PSTN_path_state AN4 (Line information). On receipt of a DISCONNECT COMPLETE message after N2 repetitions of the ESTABLISH message the IUT shall enter the PSTN_path_state AN1 (Null).

5.3.6.4 V5NWKAN/PSTN/TI/5

Initial state of the IUT: CTRL_COM_INIT, CTRL_PORT_INIT, PSTN_INIT
Preamble: PSTN_ANx_6 & PSTN_AN6_1 & PSTN_AN1_5
Postamble: PSTN_ANx_6

- TP26__S5_01 Refer to TP23__S5_04 in subclause 5.3.3.3.
- TP26__S5_02 On time-out of timer Tt after sending a SIGNAL message the IUT shall send a DISCONNECT message and enter the PSTN_path_state AN7 (Disconnect Request).
- TP26__S5_03 On receipt of a SIGNAL message containing a faulty sequence number the IUT shall send a DISCONNECT message and enter the PSTN_path_state AN7 (Disconnect Request).
- TP26__S5_04 On receipt of a SIGNAL ACK message containing a faulty sequence number after sending a SIGNAL message the IUT shall send a DISCONNECT message and enter the PSTN_path_state AN7 (Disconnect Request).

5.3.6.5 V5NWKAN/PSTN/TI/7

Initial state of the IUT: CTRL_COM_INIT, CTRL_PORT_INIT, PSTN_INIT
Preamble: PSTN_ANx_6 & PSTN_AN6_1 & PSTN_AN1_5 & PSTN_AN5_7
Postamble: PSTN_ANx_6

- TP26__S7_01 On time-out of timer T3 the IUT shall repeat sending the DISCONNECT message and remain in the PSTN_path_state AN7 (Disconnect Request). On receipt of a DISCONNECT COMPLETE message after N3 repetitions of the DISCONNECT message the IUT shall enter the PSTN_path_state AN1 (Null).
- TP26__S7_02 On time-out of timer T3 the IUT shall repeat sending the DISCONNECT message and remain in the PSTN_path_state AN7 (Disconnect Request). On N3+1 time-outs of timer T1 the IUT shall enter the PSTN_path_state AN1 (Null).

Annex A (informative): Bibliography

- ETS 300 406: "Methods for Testing and Specification (MTS); Protocol and profile conformance testing specifications; Standardization methodology".

History

Document history			
October 1995	First Edition		
December 1997	Public Enquiry	PE 9815:	1997-12-12 to 1998-10-04
January 1999	Vote	V 9912:	1999-01-19 to 1999-03-19
April 1999	Second Edition		