



EUROPEAN
TELECOMMUNICATION
STANDARD

DRAFT
pr **ETS 300 300**

May 1996

Second Edition

Source: ETSI TC-TM

Reference: RE/TM-03029

ICS: 33.080

Key words: B-ISDN, ISDN, UNI, ATM, SDH, interface, access

**Transmission and Multiplexing (TM);
Synchronous Digital Hierarchy (SDH);
SDH based user network access;
Physical layer interfaces for Broadband Integrated Services
Digital Network (B-ISDN) applications**

ETSI

European Telecommunications Standards Institute

ETSI Secretariat

Postal address: F-06921 Sophia Antipolis CEDEX - FRANCE

Office address: 650 Route des Lucioles - Sophia Antipolis - Valbonne - FRANCE

X.400: c=fr, a=atlas, p=etsi, s=secretariat - **Internet:** secretariat@etsi.fr

Tel.: +33 92 94 42 00 - Fax: +33 93 65 47 16

*

Copyright Notification: No part may be reproduced except as authorized by written permission. The copyright and the foregoing restriction extend to reproduction in all media.

© European Telecommunications Standards Institute 1996. All rights reserved.

Contents

Foreword	7
1 Scope	9
2 Normative references	9
3 Definitions and abbreviations	10
3.1 Definitions	10
3.2 Abbreviations	10
4 Reference configuration at the user-network interface	12
4.1 Functional groups and reference points	12
4.2 Examples of physical realizations	12
4.3 Basic characteristics of the interfaces at T_B and S_B reference points	16
4.3.1 Characteristics of the interfaces at 155 520 kbit/s	16
4.3.1.1 Interface at the T_B reference point	16
4.3.1.2 Interface at the S_B reference point	16
4.3.1.3 Relationship between interfaces at S_B and T_B	16
4.3.2 Characteristics of the interfaces at 622 080 kbit/s	16
4.3.2.1 Interface at T_B reference point	16
4.4 Relationship between ISDN interfaces	16
4.5 Functional groups characteristics	16
4.5.1 Network termination 1 for B-ISDN (B-NT1)	16
4.5.2 Network termination 2 for B-ISDN (B-NT2)	16
4.5.3 Terminal equipment for B-ISDN (B-TE)	17
4.5.3.1 Terminal equipment type 1 for B-ISDN (B-TE1)	17
4.5.3.2 Terminal equipment type 2 for B-ISDN (B-TE2)	17
4.5.4 Terminal adapter for B-ISDN (B-TA)	17
5 UNI specifications	17
5.1 Interface location with respect to reference configuration	17
5.2 Interface location with respect to the wiring configuration	18
6 Service and layering aspects of the physical layer	18
6.1 Services provided to the ATM-layer	18
6.2 Service primitives exchanged with the ATM layer	18
6.3 Sublayering of the physical layer	18
7 Physical medium characteristics of the UNI at 155 520 kbit/s	19
7.1 Characteristics of the interface at the T_B and S_B reference point	19
7.1.1 Bit rate and interface symmetry	19
7.1.2 Physical characteristics	19
7.1.2.1 Electrical interface	19
7.1.2.1.1 Interface range	19
7.1.2.1.2 Transmission medium	19
7.1.2.1.3 Electrical parameters at interface points I_a and I_b	19
7.1.2.1.4 Electrical connectors	19
7.1.2.1.5 Line coding	20
7.1.2.1.6 Electro-Magnetic Compatibility (EMC) and Electro-Magnetic Interference (EMI) requirements	20
7.1.2.2 Optical interface	22
7.1.2.2.1 Attenuation range	22
7.1.2.2.2 Transmission medium	22

	7.1.2.2.3	Optical parameters.....	22
	7.1.2.2.3.1	Line coding.....	22
	7.1.2.2.3.2	Operating wavelength.....	22
	7.1.2.2.3.3	Input and output port characteristics....	22
	7.1.2.2.4	Optical connectors.....	22
	7.1.2.2.5	Safety requirements.....	22
	7.1.3	Jitter and Wander.....	23
8		Physical medium characteristics of the UNI at 622 080 kbit/s.....	23
	8.1	Characteristics of the interface at the T _B and S _B reference point.....	23
	8.1.1	Bit rate and interface symmetry.....	23
	8.1.2	Physical characteristics.....	23
	8.1.2.1	Attenuation range.....	23
	8.1.2.2	Transmission medium.....	23
	8.1.2.3	Optical parameters.....	23
	8.1.2.3.1	Line coding.....	23
	8.1.2.3.2	Operating wavelength.....	23
	8.1.2.3.3	Input and output port characteristics....	24
	8.1.2.4	Optical connectors.....	24
	8.1.2.5	Safety requirements.....	24
	8.1.3	Jitter and Wander.....	24
9		Power feeding.....	24
	9.1	Provision of power.....	24
	9.2	Power available at B-NT1.....	25
	9.3	Feeding voltage.....	25
	9.4	Safety requirements.....	25
10		Functions provided by the transmission convergence sublayer.....	25
	10.1	Transfer capability.....	25
	10.1.1	Interface at 155 520 kbit/s.....	25
	10.1.2	Interface at 622 080 kbit/s.....	25
	10.2	Physical layer aspects.....	25
	10.2.1	Timing.....	25
	10.2.2	Interface structure for 155 520 kbit/s and 622 080 kbit/s.....	25
	10.2.3	Interface structure for 622 080 kbit/s.....	26
	10.3	Header error control.....	27
	10.3.1	Header error control functions.....	27
	10.3.2	Header Error Control (HEC) sequence generation.....	30
	10.4	Idle cells.....	30
	10.5	Cell delineation and scrambling.....	31
	10.5.1	Cell delineation and scrambling objectives.....	31
	10.5.1.1	Cell delineation algorithm.....	31
	10.5.2	Cell delineation performance.....	32
	10.5.3	Scrambler operation.....	32
11		UNI related OAM functions.....	32
	11.1	Transmission overhead allocation.....	33
	11.2	Maintenance signals.....	34
	11.3	Transmission performance monitoring.....	34
	11.4	Control communication.....	34
12		Operational functions.....	34
	12.1	Definition of signals at the interface.....	34
	12.1.1	Signals defined in ITU-T Recommendation I.610 [8].....	34
	12.1.2	Cell delineation signals.....	35
	12.2	Definitions of state tables at network and user sides.....	35
	12.2.1	Layer 1 states on the user side of the interface.....	36
	12.2.2	Layer 1 states at the network side of the interface.....	36
	12.2.3	Definition of primitives.....	38
	12.2.4	State tables.....	39

Annex A (informative):	Impact of random bit errors on cell delineation performance	42
Annex B (informative):	Bibliography	43
History.....		44

Blank page

Foreword

This draft second edition European Telecommunication Standard (ETS) has been produced by the Transmission and Multiplexing (TM) Technical Committee of the European Telecommunications Standards Institute (ETSI), and is now submitted for the Public Enquiry phase of the ETSI standards approval procedure.

This draft ETS has been established as a revision to the existing ETS 300 300, which defines the SDH based user network access physical layer interfaces to be applied on the T_B , S_B reference points of the reference configurations of the Broadband Integrated Services Digital Network (B-ISDN) User-Network Interface (UNI), for B-ISDN applications.

Proposed transposition dates	
Date of latest announcement of this ETS (doa):	3 months after ETSI publication
Date of latest publication of new National Standard or endorsement of this ETS (dop/e):	6 months after doa
Date of withdrawal of any conflicting National Standard (dow):	6 months after doa

Blank page

1 Scope

This draft second edition European Telecommunication Standard (ETS) defines the physical layer interface to be applied to the S_B and T_B reference points of the reference configurations of the Broadband Integrated Services Digital Network (B-ISDN) Synchronous Digital Hierarchy (SDH) based User-Network Interface (UNI) at 155 520 kbit/s and 622 080 kbit/s. It addresses separately the physical media and the transmission system used at these interfaces and addresses also the implementation of UNI related Operation And Maintenance (OAM) functions.

The selection of the physical medium for the interfaces at the S_B and T_B reference points should take into account that optical fibre is agreed as the preferred medium to be used to cable customer equipment. However, in order to accommodate existing cabling of customer equipment, other transmission media (e.g. coaxial cables) should not be precluded. Also, implementations should allow terminal interchangeability.

This draft ETS reflects in its structure and content the desire to take care of such early configurations and introduces a degree of freedom when choosing a physical medium at the physical layer.

Edition 2 of this draft ETS defines newly considered points since the finalization of edition 1 of the ETS, dealing particularly with jitter characteristics at the B-UNI, sub-rates of STM-1 applied at the S_B and T_B reference points of the reference configurations of the B-ISDN SDH - based UNI (if required in this ETS), enhanced definitions concerning the cell delineation algorithm and changes of the SDH overhead octet allocation at the B-UNI.

The production of this ETS has taken into account the recommendations given in ITU-T Recommendation I.432 [7].

2 Normative references

This ETS incorporates by dated and undated reference, provisions from other publications. These normative references are cited at the appropriate places in the text and the publications are listed hereafter. For dated references, subsequent amendments to or revisions of any of these publications apply to this ETS only when incorporated in it by amendment or revision. For undated references the latest edition of the publication referred to applies.

- [1] ITU-T Recommendation G.652: "Characteristics of a single-mode optical fibre cable".
- [2] ITU-T Recommendation G.703: "Physical/electrical characteristics of hierarchical digital interfaces".
- [3] ITU-T Recommendation G.957: "Optical interfaces for equipments and systems relating to the synchronous digital hierarchy".
- [4] ITU-T Recommendation I.113: "Vocabulary of terms for broadband aspects of ISDN".
- [5] ITU-T Recommendation I.321: "B-ISDN protocol reference model and its application".
- [6] ITU-T Recommendation I.361: "B-ISDN ATM layer specification".
- [7] ITU-T Recommendation I.432 (1992): "B-ISDN user-network interface - Physical layer specification".
- [8] ITU-T Recommendation I.610 (1992): "B-ISDN operation and maintenance principles and functions".
- [9] ITU-T Recommendation X.200: "Information technology - Open Systems Interconnection - Basic reference model: The basic model".

- [10] I-ETS 300 404: "Broadband Integrated Services Digital Network (B-ISDN); B-ISDN Operation And Maintenance (OAM) principles and functions".
- [11] IEC 825-1: "Safety of laser products: Part 1: Equipment classification requirements and user's guide".
- [12] IEC 950: "Safety of information technology equipment, including electrical business equipment".
- [13] ETS 300 232: "Transmission and Multiplexing (TM); Optical interfaces for equipments and systems relating to the Synchronous Digital Hierarchy [ITU-T Recommendation G.957 (1993) modified]".
- [14] ITU-T Recommendation G.707: "Synchronous digital hierarchy bit rates".
- [15] ITU-T Recommendation G.708: "Network node interface for the synchronous digital hierarchy".
- [16] ITU-T Recommendation G.709: "Synchronous multiplexing structure".
- [17] ITU-T Recommendation G.783: "Characteristics of synchronous digital hierarchy (SDH) equipment functional blocks".
- [18] ITU-T Recommendation G.825: "The control of jitter and wander within digital networks which are based on the synchronous digital hierarchy (SDH)".
- [19] ITU-T Recommendation G.958: "Digital line systems based on the synchronous digital hierarchy for use on optical fibre cables".

3 Definitions and abbreviations

3.1 Definitions

For the purposes of this ETS, the definitions given in ITU-T Recommendation I.113 [4] apply, in particular for the definitions of **idle cell**, **valid cell** and **invalid cell**. In addition, the following definition applies:

to be defined: These items or values are not yet specified.

3.2 Abbreviations

For the purposes of this ETS, the following abbreviations apply:

AIS	Alarm Indication Signal
ATM	Asynchronous Transfer Mode
AU	Administrative Unit
B-ISDN	Broadband Integrated Services Digital Network
B-NT	B-ISDN Network Termination
B-TA	B-ISDN Terminal Adaptor
B-TE	B-ISDN Terminal Equipment
BER	Bit Error Rate
BIP	Bit Interleaved Parity
B-UNI	Broadband integrated services digital network User Network Interface
CATV	CATegory V
CLP	Cell Loss Priority
CMI	Coded Mark Inversion
CRC	Cyclic Redundancy Check
EMC	Electro-Magnetic Compatibility
EMI	Electro-Magnetic Interference
HEC	Header Error Control
ISDN	Integrated Services Digital Network
LAN	Local Area Network

LCD	Loss of Cell Delineation
LSB	Least Significant Bit
MA	Medium Adaptor
MPH	Management Physical Header
MSB	Most Significant Bit
NNI	Network Node Interface
NRZ	Non Return to Zero
OAM	Operation and Maintenance
OCD	Out of Cell Delineation
OSI	Open System Interconnection
p.p.m	part per million
PH	Physical Header
PM	Physical Medium
POH	Path Overhead
PRBS	Pseudo Random Binary Sequence
PTR	Pointer
RDI	Remote Defect Indication
REI	Remote Error Indication
SDH	Synchronous Digital Hierarchy
SOH	Section Overhead
STI	Surface Transfer Impedance
STM	Synchronous Transport Module
TC	Transmission Convergence
TFV	Terminal Failure Voltage
TFV	Terminal Failure Voltage
UNA	User Network Access
UNI	User Network Interface
VC	Virtual Container

4 Reference configuration at the user-network interface

4.1 Functional groups and reference points

The reference configurations defined for Integrated Services Digital Network (ISDN) basic access and primary access are considered general enough to be applicable to all aspects of the B-ISDN accesses.

Figure 1 shows the B-ISDN reference configurations which contain the following:

- functional groups: B-NT1, B-NT2, B-TE1, TE2, B-TE2, and B-TA;
- reference points: T_B , S_B and R.

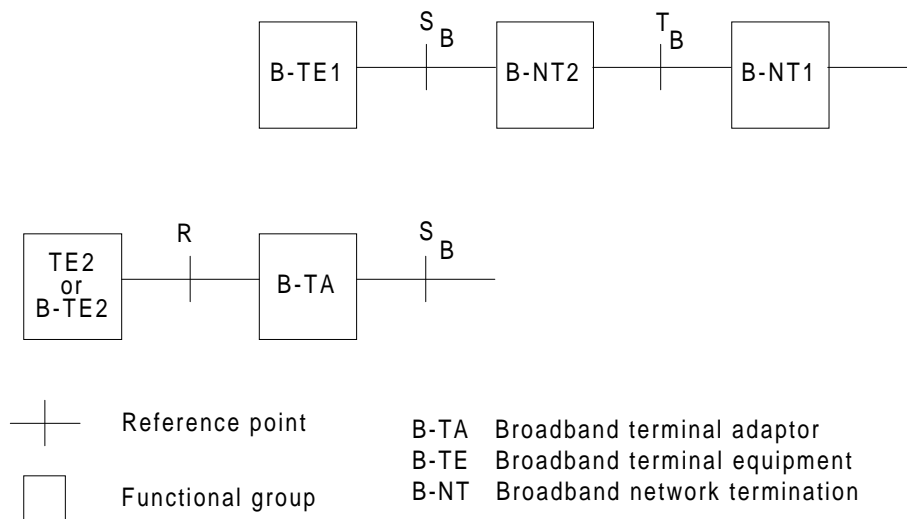

Figure 1: B-ISDN reference configurations

In order to clearly illustrate the broadband aspects, the notations for reference points and for functional groups with broadband capabilities are appended with the letter B (e.g. B-NT1, T_B). The broadband functional groups are equivalent to the functional groups defined in ISDN. Interfaces at the R reference point may or may not have broadband capabilities.

Interfaces at reference points S_B and T_B will be standardized. These interfaces will support all ISDN services.

4.2 Examples of physical realizations

Figure 2 gives examples of physical configurations illustrating combinations of physical interfaces at various reference points. The examples cover configurations that could be supported by standardized interfaces at reference points S_B and T_B . Other configurations may also exist. For example, physical configurations of B-NT2 may be distributed, or use shared medium, to support Local Area Network (LAN) emulation and other applications.

Figure 3 illustrates possible physical configurations, but does not preclude alternative configurations. Whether a single interface at the S_B reference point can cover different configurations, as illustrated in figure 3, is for further study.

Figure 2 is subdivided into separate items as follows:

- figures 2a) and 2b) show separate interfaces at the S_B and T_B reference points;
- figures 2c) and 2d) show an interface at S_B but not at T_B ;
- figures 2e) and 2f) show an interface at T_B but not at S_B ;
- figures 2g) and 2h) show separate interfaces at S , S_B and T_B ;
- figures 2i) and 2j) show interfaces at S_B and T_B which are coincident.

Additionally, figures 2b), 2d), 2f), 2h) and 2j) show an interface at reference point R.

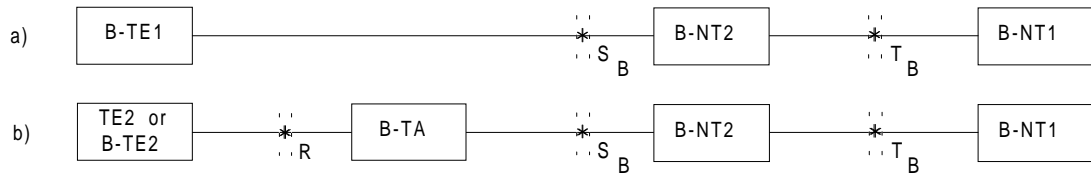

Configurations where B-ISDN physical interfaces occur at reference points S_B and T_B

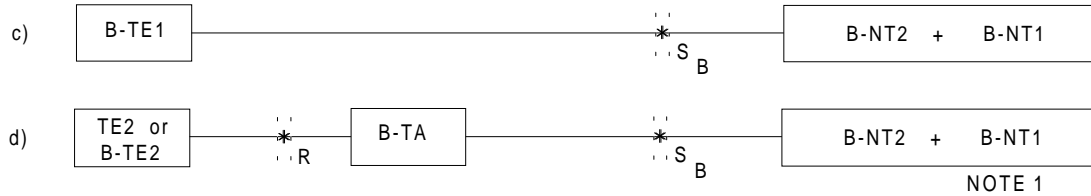

Configurations where B-ISDN physical interfaces occur at reference point S_B only

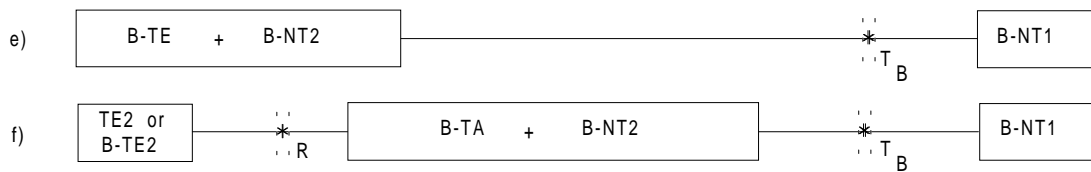

Configurations where B-ISDN physical interfaces occur at reference point T_B only

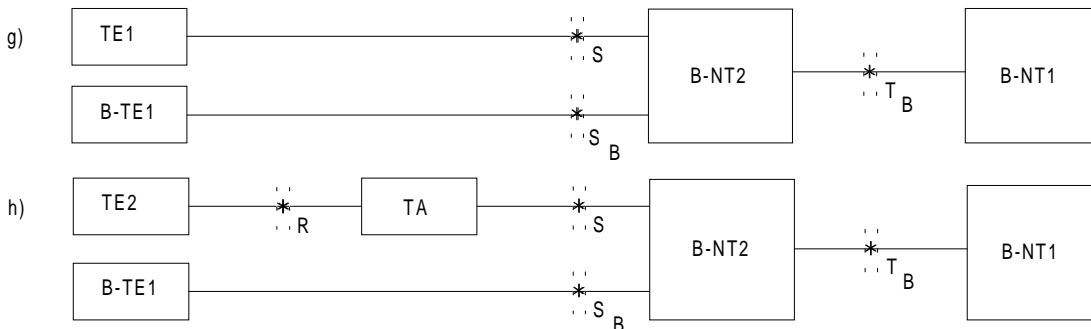

Configurations where B-ISDN and ISDN physical interfaces occur at reference points S , S_B and T_B

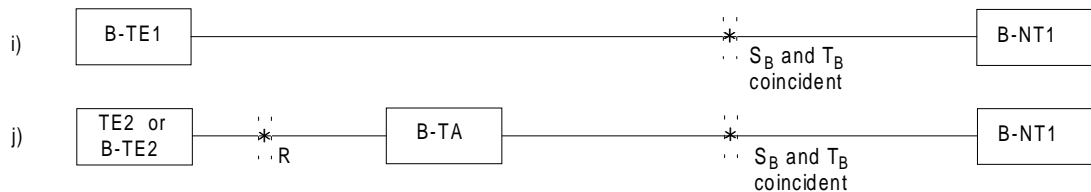

Configurations where a single B-ISDN physical interface occurs at a location where both reference points S_B and T_B coincide



NOTE 1: The need for an access to a TB-Reference point (between B-NT1 and B-NT2) is for further study.

Figure 2: Examples of physical configurations for broadband user applications

a) Centralised B-NT2 configuration:

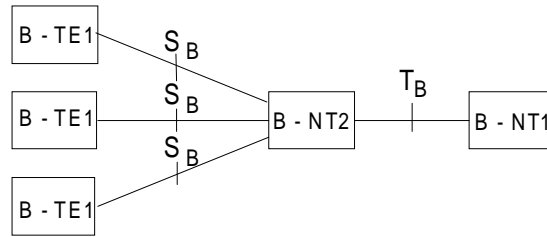

b) Distributed B-NT2 configurations:

b1) Generic configuration

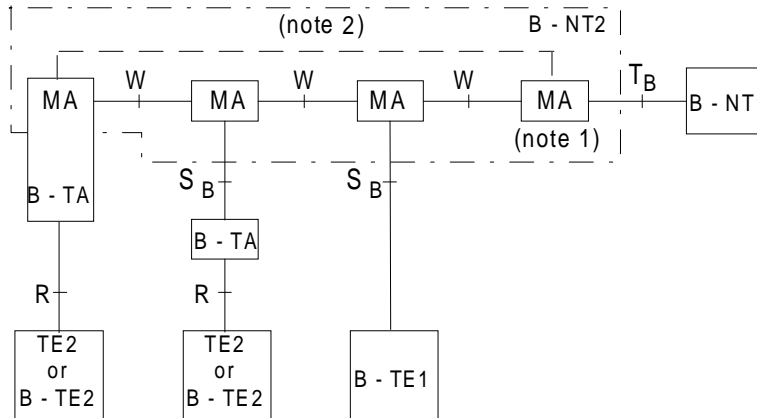

b2) Physical configurations

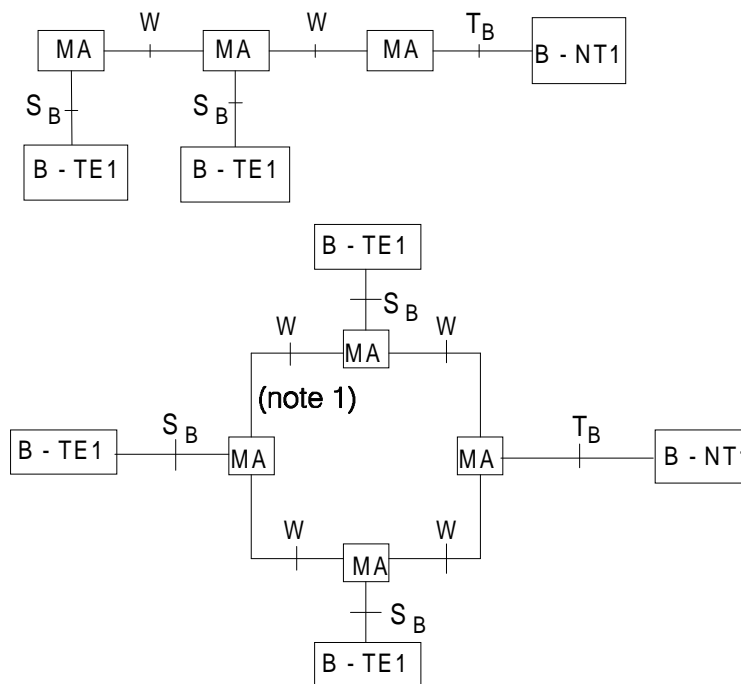
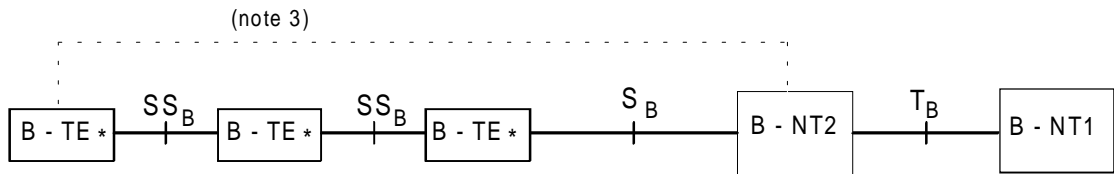

Figure 3: Examples of physical configurations for multipoint applications (continued)

c) Multi-access B-TE configurations:

c1) Generic configurations (note 7)



c2) Physical configurations

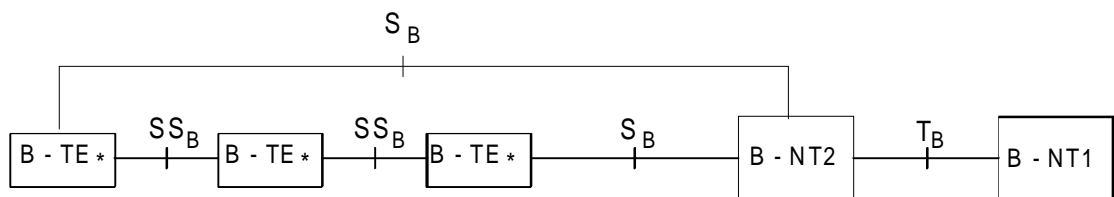
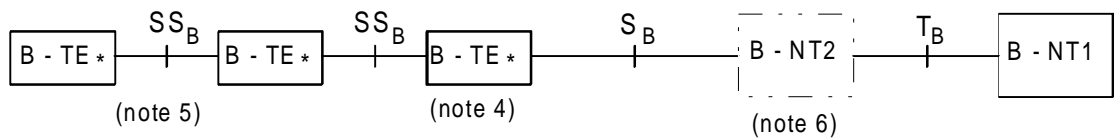
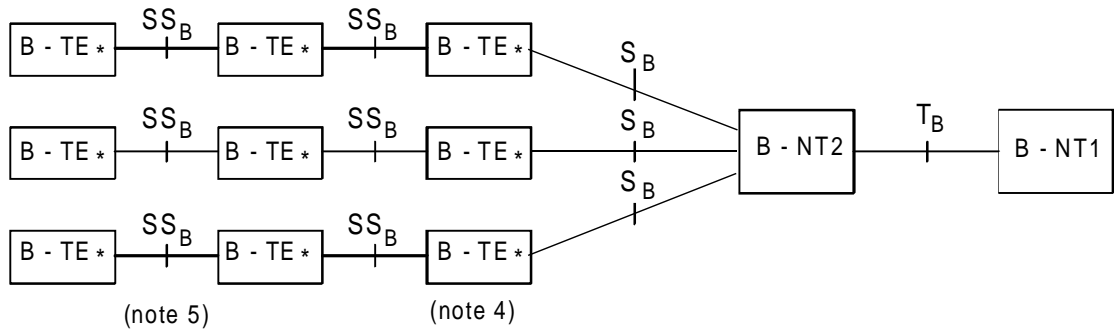

- NOTE 1: Medium Adaptor (MA): accommodates the specific topology of the distributed B-NT2. The interface at W may include topology dependant elements and may be a non-standardized interface.
- NOTE 2: There will be a physical link between these two MAs in the case of ring configurations.
- NOTE 3: There will be a physical link between B-TE* and B-NT2 in the case of ring configurations.
- NOTE 4: The B-TE* includes shared medium access functions.
- NOTE 5: The measurable physical characteristics of the SS_B interface are identical to those of the S_B interface. The functional characteristics of the interface, however, may be a superset of those at the S_B interface.
- NOTE 6: The B-NT2 may be null in the case of commonality between S_B and T_B .
- NOTE 7: Additional termination functions (e.g. for loopback in bus configuration) and OAM functions may be necessary for multi-access B-TE configurations. Requirements and implementations of these functions are for further study.

Figure 3 (concluded): Examples of physical configurations for multipoint applications

4.3 Basic characteristics of the interfaces at T_B and S_B reference points

4.3.1 Characteristics of the interfaces at 155 520 kbit/s

4.3.1.1 Interface at the T_B reference point

There is only one interface per B-NT1 at the T_B reference point. The operation of the physical medium is point-to-point in the sense that there is only one sink (receiver) in front of one source (transmitter).

Point-to-multipoint configurations at T_B at the ATM and higher layers are for further study.

4.3.1.2 Interface at the S_B reference point

One or more S_B interfaces per B-NT2 are present. The interface at the S_B reference point is point-to-point at the physical layer in the sense that there is only one sink (receiver) in front of one source (transmitter) and may be point to multipoint at the other layers.

4.3.1.3 Relationship between interfaces at S_B and T_B

Configurations described in figures 2i) and 2j) require that the interface specifications at T_B and S_B should have a high degree of commonality, in order to ensure that a simple broadband terminal may be connected directly to the T_B interface.

The feasibility of achieving the needed commonality is for further study.

4.3.2 Characteristics of the interfaces at 622 080 kbit/s

4.3.2.1 Interface at T_B reference point

There is only one interface per B-NT1 at the T_B reference point. The operation of the physical medium is point-to-point in the sense that there is only one sink (receiver) in front of one source (transmitter).

Point-to-multipoint configurations at T_B at the ATM and higher layers are for further study.

4.4 Relationship between ISDN interfaces

Figures 2g) and 2h) show configurations where B-ISDN and ISDN interfaces may occur at S_B and S respectively. In this case, B-NT2 functionalities have to ensure the interface capabilities for both S and S_B . Other configurations for supporting terminals at the interface at the S reference point may exist.

4.5 Functional groups characteristics

Lists of functions for each functional group are given below. Each particular function is not necessarily restricted to a single functional group. For example, "interface termination" functions are included in the function lists of B-NT1, B-NT2 and B-TE. The function lists for B-NT1, B-NT2, B-TE and B-TA are not exhaustive. Not all specific functions in a functional group need to be present in all implementations.

4.5.1 Network termination 1 for B-ISDN (B-NT1)

This functional group includes functions broadly equivalent to layer 1 of the Open System Interconnection (OSI) reference model. Examples of B-NT1 functions are:

- line transmission termination;
- transmission interface handling;
- OAM functions.

4.5.2 Network termination 2 for B-ISDN (B-NT2)

This functional group includes functions broadly equivalent to layer 1 and higher layers of the ITU-T Recommendation X.200 [9] reference model. B-NT2 can be null in the case of commonality between T_B and S_B .

Examples of B-NT2 functions are:

- adaptation functions for different media and topologies (MA functions);
- functions of a distributed B-NT2;
- cell delineation;
- concentration;
- buffering;
- multiplexing/demultiplexing;
- resource allocation;
- usage parameter control;
- adaptation layer functions for signalling (for internal traffic);
- interface handling (for the T_B and S_B interfaces);
- OAM functions;
- signalling protocol handling;
- switching of internal connections.

B-NT2 implementations may be concentrated or distributed. In a specific access arrangement, the B-NT2 may consist only of physical connections. When present, implementations of the B-NT2 are locally powered.

4.5.3 Terminal equipment for B-ISDN (B-TE)

This functional group includes functions broadly belonging to layer 1 and higher layers of the ITU-T Recommendation X.200 [9] reference model.

Examples of B-TE functions are:

- user/user and user/machine dialogue and protocol;
- interface termination and other layer 1 functions;
- protocol handling for signalling;
- connection handling to other equipments;
- OAM functions.

The possibility of powering the B-TE via the S_B interface is for further study.

4.5.3.1 Terminal equipment type 1 for B-ISDN (B-TE1)

This functional group includes functions belonging to the B-TE functional group with an interface that complies with the B-ISDN S_B and/or T_B interface ITU-T Recommendations.

4.5.3.2 Terminal equipment type 2 for B-ISDN (B-TE2)

This functional group includes functions belonging to the functional group B-TE but with a broadband interface that complies with interface ITU-T Recommendations other than the B-ISDN interface ITU-T Recommendations or interfaces not included in ITU-T Recommendations.

4.5.4 Terminal adapter for B-ISDN (B-TA)

This functional group includes functions broadly belonging to layer 1 and higher layers of the ITU-T Recommendation X.200 [9] reference model that allow a TE2 or a B-TE2 terminal to be served by a B-ISDN UNI.

5 UNI specifications

5.1 Interface location with respect to reference configuration

An interface point I_a is adjacent to the B-TE or the B-NT2 on their network side; interface point I_b is adjacent to the B-NT2 and to the B-NT1 on their user side (see figure 4).

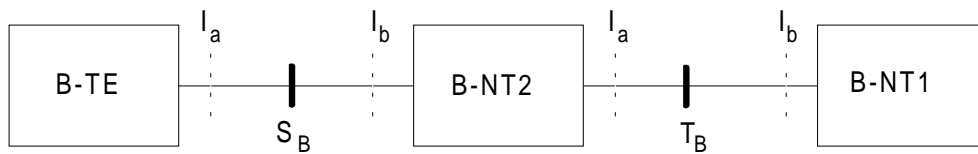
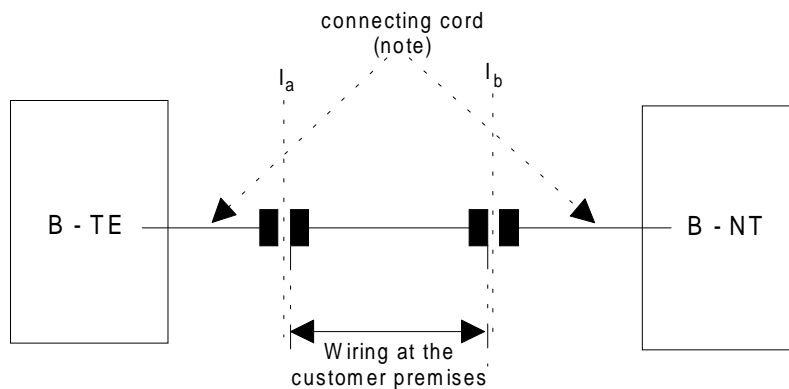

Figure 4: Reference configuration at reference points S_B and T_B

5.2 Interface location with respect to the wiring configuration

The interface points are located between the socket and the plug of the connector attached to the B-TE, B-NT2 or B-NT1. The location of the interface point is shown in figure 5.

In this ETS, the term "B-NT" is used to indicate network terminating layer 1 aspects of B-NT1 and B-NT2 functional groups, and the term "TE" is used to indicate terminal terminating layer 1 aspects of B-TE1, B-TA and B-NT2 functional groups, unless otherwise indicated.



NOTE: The length of the connecting cord can be zero.

Figure 5: Wiring configuration

6 Service and layering aspects of the physical layer

6.1 Services provided to the ATM-layer

The physical layer provides for the transparent transmission of ATM-PDUs between physical layer service access points (Ph-SAP). The ATM-PDU is called the ATM cell. The ATM cell is defined in ITU-T Recommendation I.361 [6]. As no addressing is implemented in the physical layer only a single Ph-SAP can exist at the boundary between the physical layer and the ATM layer. The interarrival time between cells passed to the ATM layer is not defined (asynchronous transmission). The physical layer provides the ATM layer with timing information.

6.2 Service primitives exchanged with the ATM layer

The service primitives between the physical layer and the ATM layer are defined in ITU-T Recommendation I.361 [6], § 3.2.

6.3 Sublayering of the physical layer

The physical layer is subdivided into two sublayers:

- the Physical Medium (PM) sublayer;
- the Transmission Convergence (TC) sublayer.

No service access point and service primitives are defined between the PM and the TC sublayers. The functions of the individual sublayer are defined in ITU-T Recommendation I.321 [5].

7 Physical medium characteristics of the UNI at 155 520 kbit/s

7.1 Characteristics of the interface at the T_B and S_B reference point

7.1.1 Bit rate and interface symmetry

The bit rate of the interface is 155 520 kbit/s. The interface is symmetric, i.e. it has the same bit rate in both transmission directions.

The nominal bit rate in free running clock mode shall be 155 520 kbit/s with a tolerance of ± 20 p.p.m.

7.1.2 Physical characteristics

Both optical and electrical interfaces are recommended. The implementation selected depends on the distance to be covered and user requirements arising from the details of the installation.

7.1.2.1 Electrical interface

7.1.2.1.1 Interface range

The maximum range of the interface depends on the specific attenuation of the transmission medium used. For example a maximum range of about 100 meters for microcoax (4 mm diameter) and 200 meters for Category V (CATV) type (7 mm diameter) can be achieved.

7.1.2.1.2 Transmission medium

Two coaxial cables, one for each direction, shall be used. The wiring configuration shall be point-to-point.

The impedance shall be 75 Ω with a tolerance of $\pm 5\%$ in the frequency range 50 MHz to 200 MHz.

The attenuation of the electrical path between the interface points I_a and I_b shall be assumed to follow an approximate \sqrt{f} law and to have a maximum insertion loss of 20 dB at a frequency of 155 520 kHz.

7.1.2.1.3 Electrical parameters at interface points I_a and I_b

The digital signal presented at the output port and the port impedance should conform to table 11 and figures 24 and 25 of ITU-T Recommendation G.703 [2] for the interface at 155,520 Mbit/s.

The digital signal presented at the input port and the port impedance should conform to table 11 and figures 24 and 25 of ITU-T Recommendation G.703 [2] for the interface at 155,520 Mbit/s, modified by the characteristics of the interconnecting coaxial pair.

7.1.2.1.4 Electrical connectors

The presentation of interface point I_b at B-NT1 or B-NT2 shall be via a socket. The presentation of interface point I_a at B-TE or B-NT2 shall be using either:

- a) a socket, i.e. the connection shall be made to the equipment toward the network with a cable with plugs on both ends; or
- b) an integral connecting cord with plug on the free end.

See figure 6 for connector types.

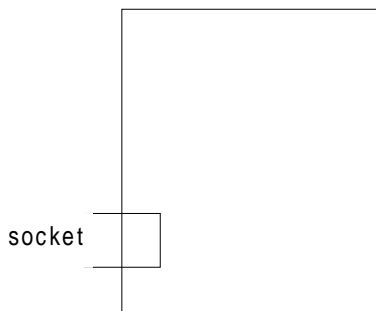

Presentation of interface point 1b at B-NT1 and B-NT2

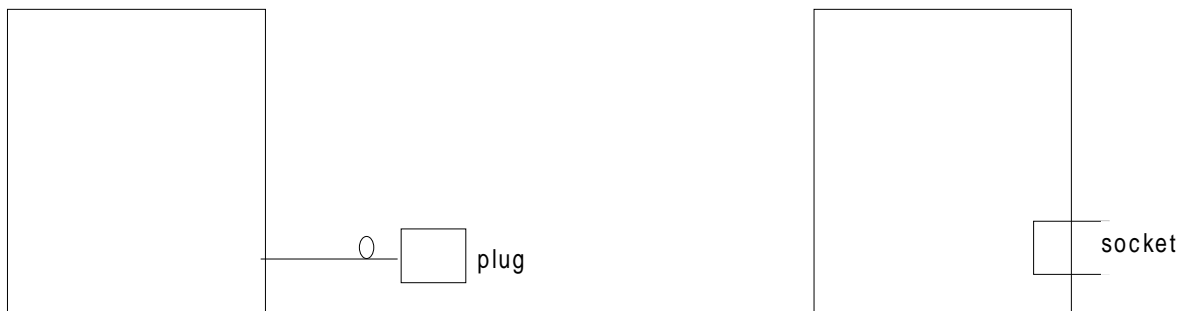

Presentation of interface point 1a at B-TE and B-NT2

Figure 6: Connector types

7.1.2.1.5 Line coding

The line coding shall be Coded Mark Inversion (CMI), see ITU-T Recommendation G.703 [2], § 12.1.

7.1.2.1.6 Electro-Magnetic Compatibility (EMC) and Electro-Magnetic Interference (EMI) requirements

Shielding properties of connectors and cables are defined by the specification of the respective values for the Surface Transfer Impedance (STI). The template indicating the maximum STI values for CATV cables is given in figure 7. For connectors, these template values shall be multiplied by 10 (i.e. +20 dB).

The immunity of the interface against induced noise on the transmission medium should be specified by means of a Terminal Failure Voltage (TFV) which is overlaid to the digital signal at the output port. Figure 8 shows a possible measurement configuration.

The receiver should tolerate a sinusoidal TFV with the values defined in figure 9 and table 1 without degradation of the Bit Error Rate (BER) performance.

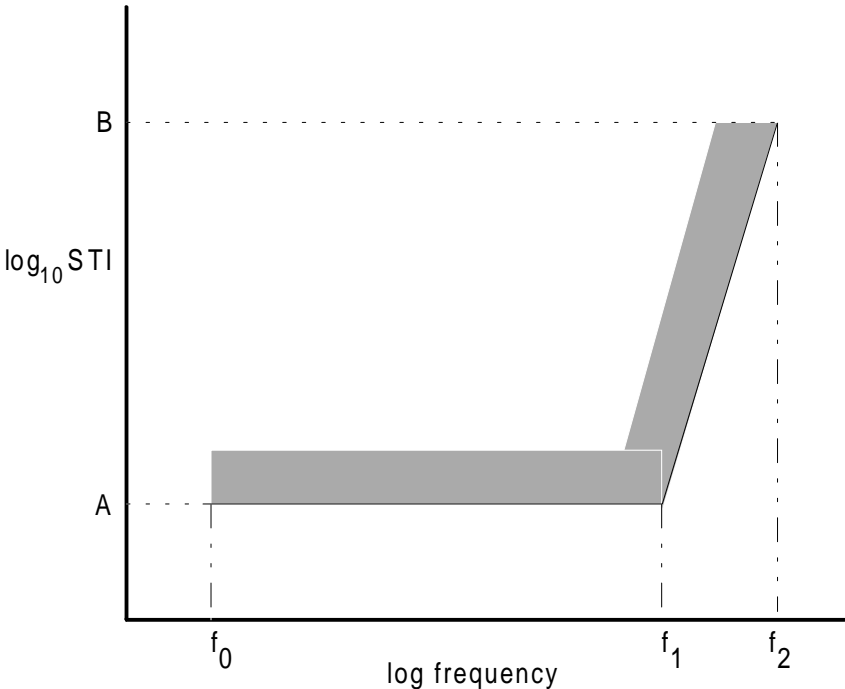

frequency (MHz):	STI value (Ω/m):
$f_0 = 0,1$	$A = 0,01$
$f_1 = 100$	$B = 1$
$f_2 = 1\ 000$	

NOTE: The applicability of these values for microcoax cables is for further study.

Figure 7: Maximum STI values as a function of frequency

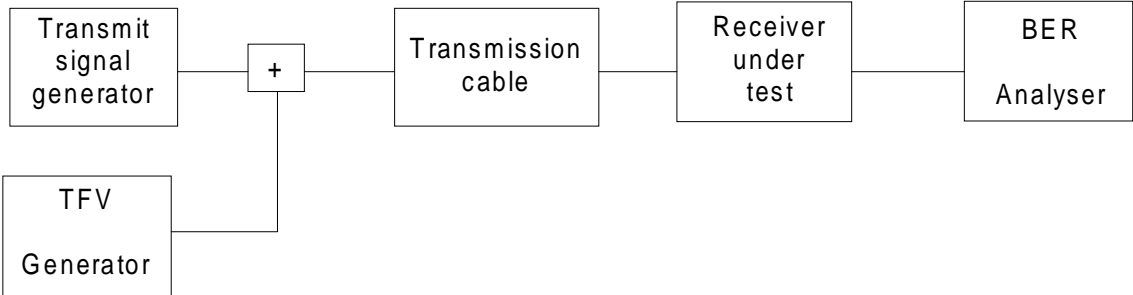

Figure 8: Measurement configuration

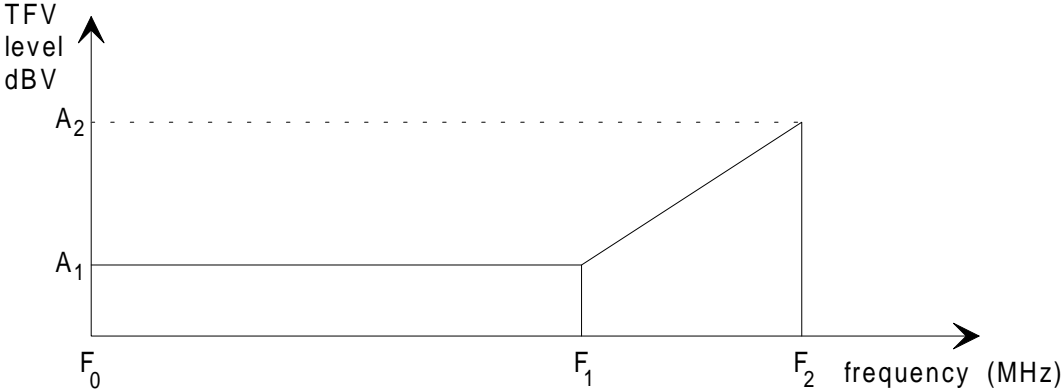

Figure 9: Terminal Failure Voltage (TFV) frequency response

Table 1: Terminal Failure Voltage (TFV) values

frequency (MHz)	TFV amplitude (dBV) (0 dBV = 1 V _{op})
F ₀ = 1 F ₁ = 200 F ₂ = 400	A1 ≥ -17 A2 ≥ -11

7.1.2.2 Optical interface

7.1.2.2.1 Attenuation range

The attenuation of the optical path between the specification points S and R shall be in the range of 0 dB to 7 dB (see subclause 7.1.2.2.3.3).

7.1.2.2.2 Transmission medium

The transmission medium shall consist of two single mode fibres according to ITU-T Recommendation G.652 [1], one for each direction.

7.1.2.2.3 Optical parameters

7.1.2.2.3.1 Line coding

The line coding shall be binary Non Return to Zero (NRZ). The convention used for optical logic level is:

- emission of light for a binary ONE;
- no emission of light for a binary ZERO.

The extinction ratio shall be in accordance with ITU-T Recommendation G.957 [3], application code I-1.

7.1.2.2.3.2 Operating wavelength

The operating wavelength shall be around 1 310 nm (second window).

7.1.2.2.3.3 Input and output port characteristics

The optical parameters shall be in accordance with ETS 300 232 [13], application code I-1.

The specification points associated with interface points I_a and I_b correspond to measurement "reference points" S and R as defined in ETS 300 232 [13]. The optical parameters are specified for the transmitter and receiver at these specification points and for the optical path between these specification points, i.e. the connector at the interface is considered to be part of the equipment and not part of the fibre installation.

7.1.2.2.4 Optical connectors

The presentation of interface point I_b at B-NT1 or B-NT2 shall be via a socket.

The presentation of interface point I_a at B-TE or B-NT2 shall be using either:

- a socket, i.e. the connection shall be made to the equipment toward the network with a cable with plugs on both ends; or
- an integral connecting cord with plug on the free end.

7.1.2.2.5 Safety requirements

For safety reasons, the parameters for IEC 825-1 [11], Class 1 devices shall not be exceeded, even under failure conditions.

7.1.3 Jitter and Wander

For both electrical and optical B-UNI, the interface output jitter shall be in accordance with the appropriate limits given in ITU-T Recommendation G.825 [18] for the electrical and optical interface.

Equipments having an electrical or optical B-UNI (e.g., B-NT1, B-NT2, B-TE) and which meet the input jitter tolerance and the jitter transfer specifications given in ITU-T Recommendations G.825 [18] and G.958 [19] respectively, are assured of proper operation when the interface output jitter conforms to the limits in ITU-T Recommendation G.825 [18].

8 Physical medium characteristics of the UNI at 622 080 kbit/s

8.1 Characteristics of the interface at the T_B and S_B reference point

8.1.1 Bit rate and interface symmetry

The bit rate of the interface in at least one direction shall be 622 080 kbit/s. The following possible interfaces have been identified:

- a) an asymmetrical interface with 622 080 kbit/s in one direction and 155 520 kbit/s in the other direction;
- b) a symmetrical interface with 622 080 kbit/s in both directions.

If option a) is chosen, then the 155 520 kbit/s component shall comply with the characteristics as given in clause 7.

The nominal bit rate in free running clock mode shall be 622 080 kbit/s with a tolerance of ± 20 p.p.m.

8.1.2 Physical characteristics

For the purposes of this ETS, only the optical interface is considered.

8.1.2.1 Attenuation range

The attenuation of the optical path between the specification points S and R shall be in the range of 0 dB to 7 dB (see subclause 7.1.2.3.3).

8.1.2.2 Transmission medium

The transmission medium shall consist of two single-mode fibres according to ITU-T Recommendation G.652 [1], one for each direction.

8.1.2.3 Optical parameters

8.1.2.3.1 Line coding

The line coding shall be binary Non Return to Zero (NRZ).

The convention used for optical logic level is:

- emission of light for a binary ONE;
- no emission of light for a binary ZERO.

The extinction ratio shall be in accordance with ITU-T Recommendation G.957 [3], application code I-4.

8.1.2.3.2 Operating wavelength

The operating wavelength shall be around 1 310 nm (second window).

8.1.2.3.3 Input and output port characteristics

The optical parameters shall be in accordance with ETS 300 232 [13], application code I-4.

The specification points associated with interface points I_a and I_b correspond to measurement "reference points" S and R as defined in ETS 300 232 [13]. The optical parameters are specified for the transmitter and receiver at these specification points and for the optical path between these specification points, i.e. the connector at the interface is considered to be part of the equipment and not part of the fibre installation.

8.1.2.4 Optical connectors

The presentation of interface point I_b at B-NT1 or B-NT2 shall be via a socket.

The presentation of interface point I_a at B-TE or B-NT2 shall be using either:

- a) a socket, i.e. the connection shall be made to the equipment toward the network with a cable with plugs on both ends; or
- b) an integral connecting cord with plug on the free end.

8.1.2.5 Safety requirements

For safety reasons, the parameters for IEC 825-1 [11], Class 1 devices shall not be exceeded even under failure conditions.

8.1.3 Jitter and Wander

For both electrical and optical B-UNI, the interface output jitter shall be in accordance with the appropriate limits given in ITU-T Recommendation G.825 [18] for the electrical and optical interface.

Equipments having an electrical or optical B-UNI (e.g., B-NT1, B-NT2, B-TE) and which meet the input jitter tolerance and the jitter transfer specifications given in ITU-T Recommendations G.825 [18] and G.958 [19] respectively, are assured of proper operation when the interface output jitter conforms to the limits in ITU-T Recommendation G.825 [18].

9 Power feeding

9.1 Provision of power

The provision of power to the B-NT1 via the UNI is optional. If the power is provided via the UNI, the following conditions shall apply:

- a separate pair of wires shall be used for the provision of power to the B-NT1 via the T_B reference point;
- the power sink shall be fed by either:
 - a source under the responsibility of the user when requested by the network provider;
 - a power supply unit under the responsibility of the network provider connected to the mains electric supply in the customer premises;
- the capability of the provision of power by the user side shall be available either:
 - as an integral part of the B-NT2/B-TE; and/or
 - physically separated from the B-NT2/B-TE as an individual power supply unit;
- a power source capable to feed more than one B-NT1 shall meet the requirements at each individual B-NT1 power feeding interface at the same point in time;
- a short-circuit or overload condition in any B-NT1 shall not affect the power feeding interface of the other B-NT1's.

9.2 Power available at B-NT1

If the power of the B-NT1 is provided via the T_B reference point, the power available at the B-NT1 shall be at least 15 W.

9.3 Feeding voltage

The feeding voltage at the B-NT1 shall be in the range of -20 V to -57 V relative to ground.

9.4 Safety requirements

In order to harmonize power source and sink requirements the following is required:

- 1) the power source shall be protected against short-circuits and overload;
- 2) the power sink of B-NT1 shall not be damaged by an interchange of wires.

With respect to the feeding interface of the power source, which is regarded as a touchable part in the sense of IEC 950 [12], the protection methods against electric shock specified in IEC 950 [12] may be applied.

10 Functions provided by the transmission convergence sublayer

10.1 Transfer capability

10.1.1 Interface at 155 520 kbit/s

At the physical level, at the interface at the T_B reference point the bit rate shall be 155 520 kbit/s. The maximum bit rate available for user information cells, signalling cells and the ATM and higher layers OAM information cells, excluding physical layer frame structure octets is 149 760 kbit/s.

10.1.2 Interface at 622 080 kbit/s

At the physical level, at the interface at the T_B reference point the bit rate shall be 622 080 kbit/s in at least one direction (see subclause 8.1.1). The maximum bit rate available for user information cells, signalling cells and the ATM and higher layers OAM information cells, excluding physical layer frame structure octets is 599 040 kbit/s.

10.2 Physical layer aspects

The ATM cell structure shall be as defined in ITU-T Recommendation I.361 [6] and ATM cells are carried in a SDH based frame structure.

10.2.1 Timing

In normal operation, timing for the transmitter is locked to the timing received from the network clock and derived from the line rate of the physical layer.

The tolerance under fault conditions shall be 155 520 kbit/s \pm 20 p.p.m.

10.2.2 Interface structure for 155 520 kbit/s and 622 080 kbit/s

The bit stream of the interface has an external frame based on the SDH, as described in ITU-T Recommendations G.707 [14], G.708 [15], and G.709 [16]. Specifically, the frame is given in ITU-T Recommendation G.709 [16], and is illustrated in figure 10. The application of the SDH frame synchronous scrambler is described in ITU-T Recommendation G.709 [16] § 2.

The ATM cell stream is first mapped into the C-4 and then mapped in the VC-4 container along with the VC-4 path overhead (see figure 10). The ATM cell boundaries are aligned with the Synchronous Transport Module 1 (STM-1) octet boundaries. Since the C-4 capacity (2 340 octets) is not an integer multiple of the cell length (53 octets), a cell may cross a C-4 boundary.

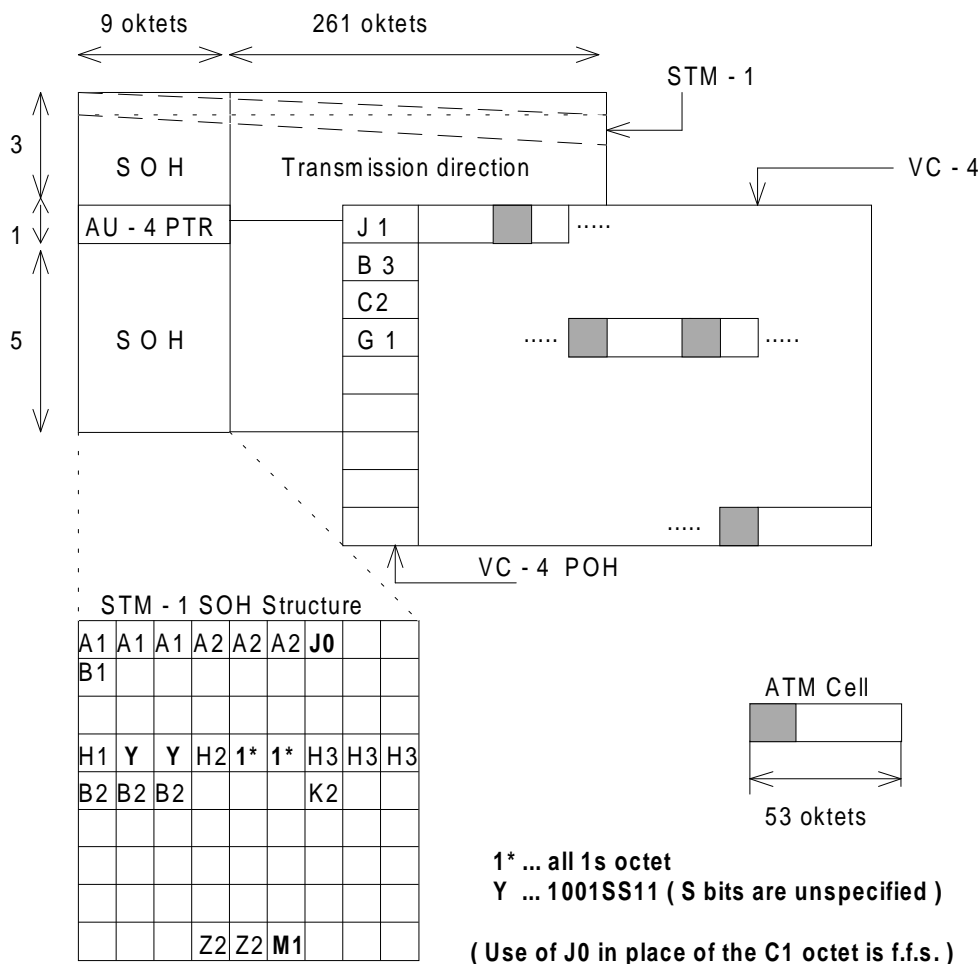

Figure 10: 155 520 kbit/s frame structure

The AU-4 pointer (octets H1 and H2 in the SOH) is used for finding the first octet of the VC-4. Path Overhead (POH) octets J1, B3, C2, and G1, are utilised. Use of the remaining POH octets is for further study.

For all representations shown in this ETS in binary format, bits are numbered within the octet as shown in figure 11, with the order of transmission being from left to right.

MSB							LSB
1	2	3	4	5	6	7	8

First Bit Transmitted ⇒ ⇒ ⇒ ⇒ ⇒ Last Bit Transmitted

NOTE: The bit numbering used in this figure is different from the convention used in ITU-T Recommendation I.361 [6] but is in accordance with ITU-T Recommendation G.709 [16].

Figure 11: Order of transmission of bits within a byte

10.2.3 Interface structure for 622 080 kbit/s

The bit stream of the interface has an external frame based on the SDH as described in ITU-T Recommendations G.707 [14], G.708 [15], G.709 [16]. Specifically, the AU-4-4c structure as given in ITU-T Recommendation G.709 [16] § 3.1.7 is specified, and is illustrated in figure 12. The application of the SDH frame synchronisation scrambler is described in ITU-T Recommendation G.709 [16] § 2.4.

The ATM cell stream is first mapped into the C-4-4c and then packed in the VC-4-4c container along with the VC-4-4c path overhead (see figure 12). The ATM cell boundaries are aligned with the STM-4 octet boundaries. Since the C-4-4c capacity (9 360 octets) is not an integer multiple of the cell length (53 octets), a cell may cross a C-4-4c boundary.

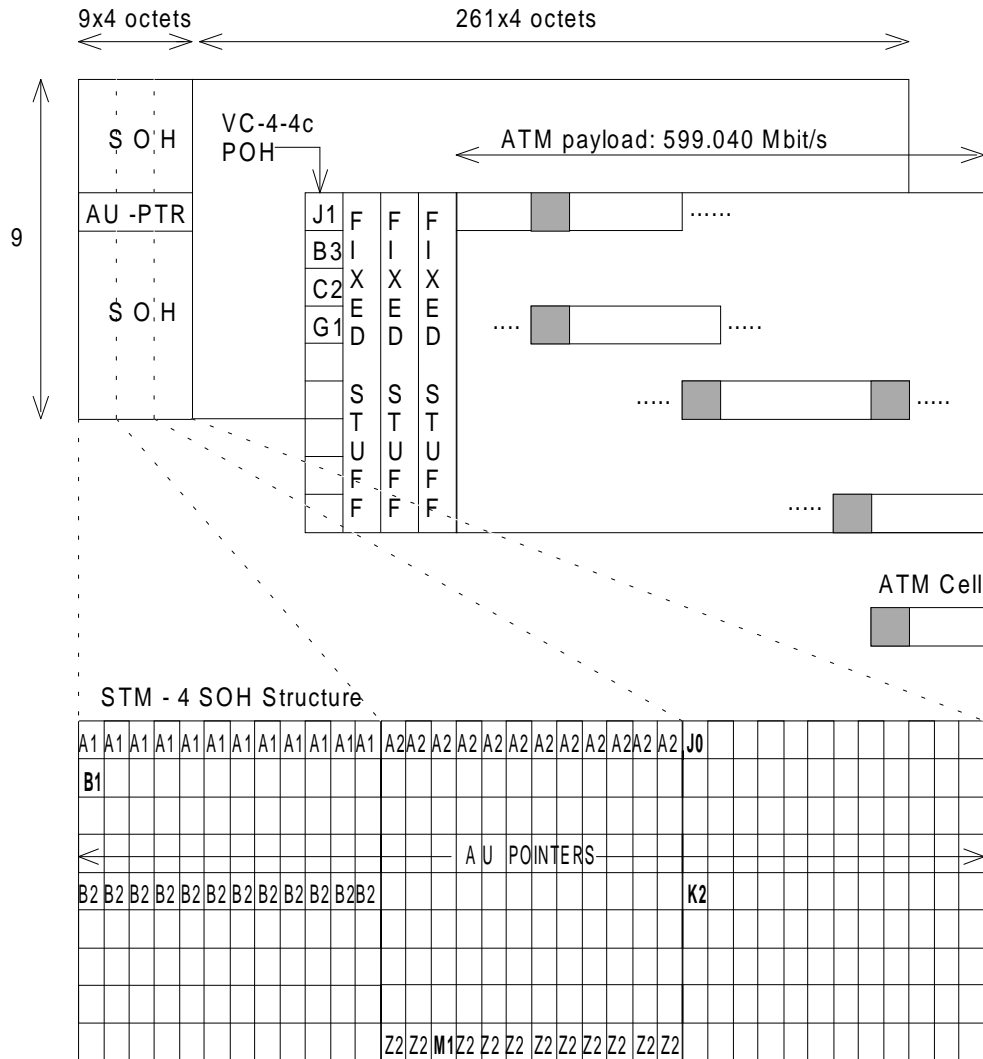

(Use of J0 in place of the C1 octet is for further study)

Figure 12: 622 080 kbit/s frame structure

The AU-pointers are used for finding the first octet of the VC-4-4c. Path overheads octets J1, B3, C2, and G1 are utilised. Use of the remaining POH octets is for further study.

10.3 Header error control
10.3.1 Header error control functions

The Header Error Control (HEC) covers the entire cell header. The code used for this function is capable of either:

- single bit error correction; or
- multiple bit error detection.

The detailed description of the HEC procedure is given in subclause 10.3.2. Briefly, the transmitting side computes the HEC field value. The receiver has two modes of operation as shown in figure 13. The default mode provides for single-bit error correction. Each cell header is examined and, if an error is

detected, one of two actions takes place. The action taken depends on the state of the receiver. In "correction mode" only single bit errors can be corrected and the receiver switches to "detection mode". In "detection mode", all cells with detected header errors are discarded. When a header is examined and found not to be in error, the receiver switches to "correction mode". The term "no action" in figure 13 means no correction is performed and no cell is discarded.

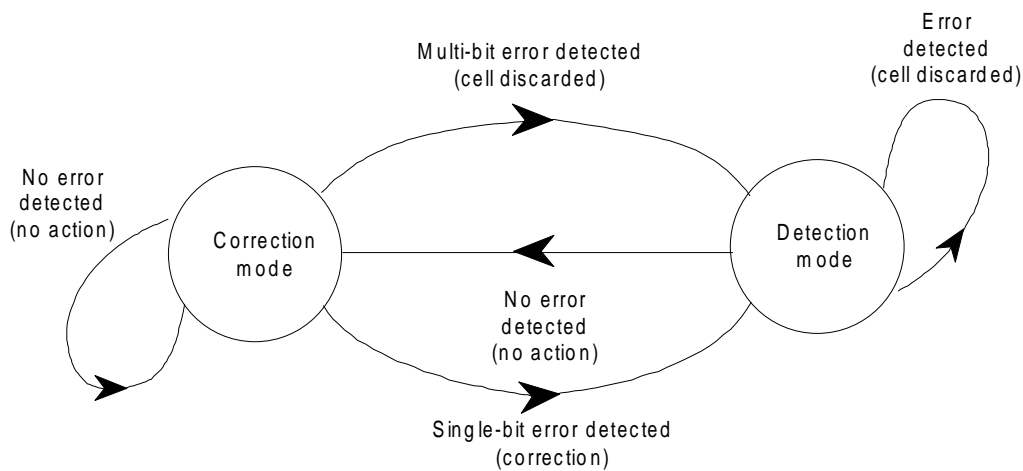
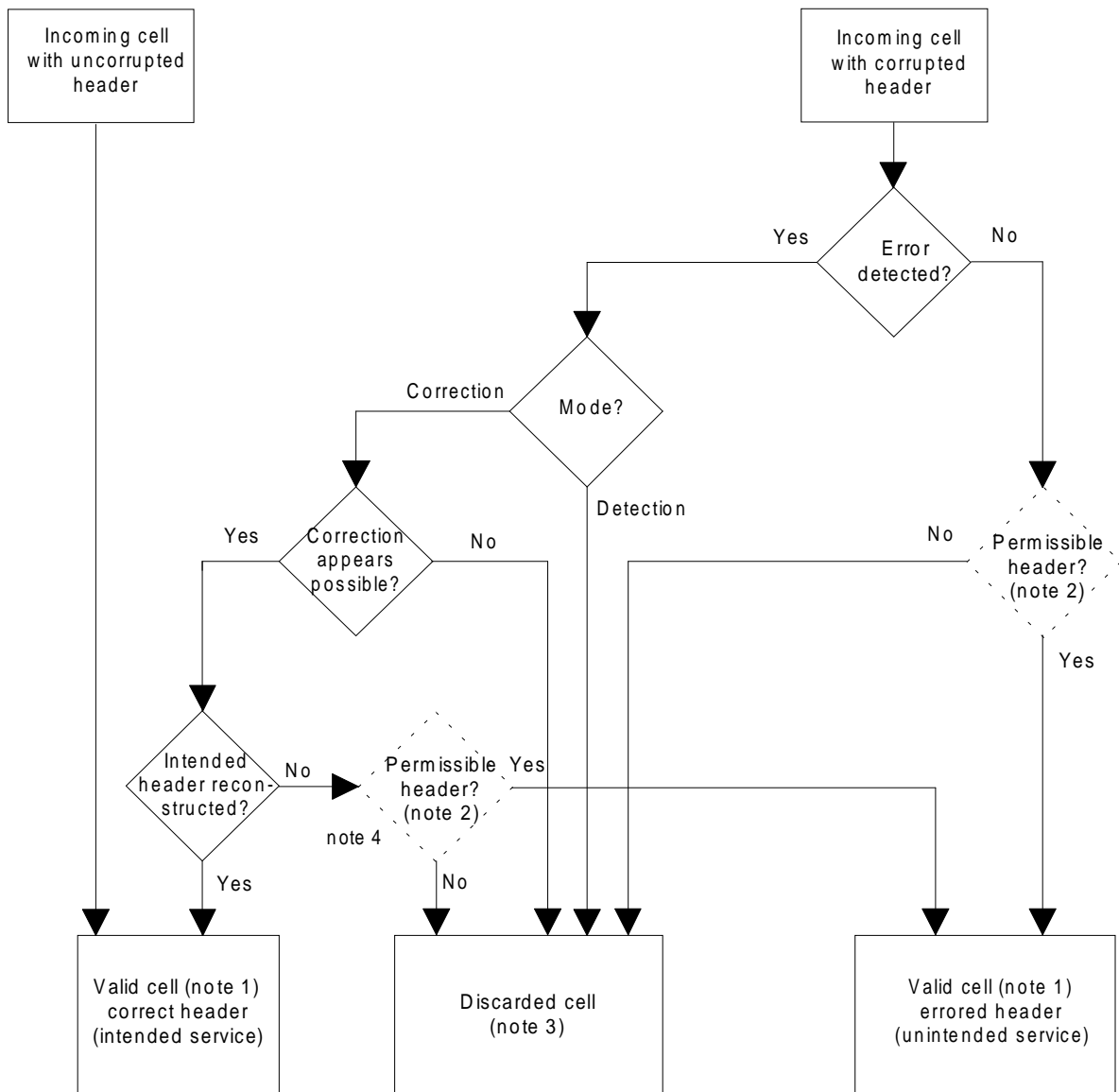



Figure 13: Header Error Control (HEC) - receiver modes of operation

The flow chart given in figure 14 shows the consequence of errors in the ATM cell header. The error protection function provided by the HEC provides both recovery from single bit header errors, and a low probability of the delivery of cells with errored headers under bursty error conditions. The error characteristics of fibre based transmission systems appear to be a mix of single-bit errors and relatively large burst errors. For some transmission systems, the error correction capability may not be invoked.



 – Functions usually performed by the ATM layer

NOTE 1: Intended service means the service requested by the originator, while unintended service means a possible service, but not that required by the originator. Definition of "valid cell": a cell where the header is declared by the header error control process to be free of errors (ITU-T Recommendation I.113 [4]).

NOTE 2: An example of an impermissible header is a header whose VPI/VCI is neither allocated to a connection nor pre-assigned to a particular function (idle cell, OAM cell, etc.). In many instances, the ATM-layer will decide if the cell header is permissible.

NOTE 3: A cell is discarded if its header is declared to be invalid, or if the header is declared to be valid and the resulting header is impermissible.

NOTE 4: Some of the tests shown are just for explanation and not implementable as such. Specially, those for error detection and intended header reconstructed. Definition of "intended header": the header generated by the transmitting device, as it was before being corrupted by one or more errors.

Figure 14: Consequences of errors in ATM cell header

10.3.2 Header Error Control (HEC) sequence generation

The transmitter calculates the HEC value across the entire ATM cell header and inserts the result in the appropriate header field.

The notation used to describe the HEC is based on the property of cyclic codes. (For example code vectors such as "1000 0001 00001" can be represented by a polynomial $P(x) = x^{12} + x^5 + 1$). The elements of a n-element code word are, thus, the coefficients of a polynomial of order n-1. In this application, these coefficients can have the value 0 or 1 and the polynomial operations are performed using modulo 2 operations. The polynomial representing the content of a header excluding the HEC field is generated using the first bit of a header as the coefficient of the highest order term.

The HEC field shall be an 8-bit sequence. It shall be the remainder of the division (modulo 2) by the generator polynomial $G(x) = x^8 + x^2 + x + 1$ of the product x^8 , multiplied by the content of the header excluding the HEC field.

At the transmitter, the initial content of the register of the device computing the remainder of the division is pre-set to all 0s and is then modified by division of the header excluding the HEC field by the generator polynomial (as described above); the resulting remainder is transmitted as the 8-bit HEC.

To significantly improve the cell delineation performance in the case of bit-slips the following is recommended:

- the check bits calculated by the use of the check polynomial are added (modulo 2) to an 8-bit pattern before being inserted in the last octet of the header;
- the recommended pattern is "0101 0101" (the left bit is the most significant bit);
- the receiver shall subtract (which is equal to add modulo 2) the same pattern from the 8 HEC bits before calculating the syndrome of the header.

This operation in no way affects the error detection/correction capabilities of the HEC. As an example if the first 4 octets of the header were all zeros the generated header before scrambling would be "00000000 00000000 00000000 00000000 01010101". The starting value for the polynomial check is all "0s".

10.4 Idle cells

Idle cells cause no action at a receiving node except for cell delineation including HEC verification. They are inserted and discarded for cell rate decoupling.

Idle cells are identified by the standardized pattern for the cell header shown in table 2.

Table 2: Header pattern for idle cell identification

	Octet 1	Octet 2	Octet 3	Octet 4	Octet 5
Header pattern	00000000	00000000	00000000	00000001	HEC = Valid code = 01010010

There is no significance to any of these individual fields from the point of view of the ATM layer, as physical layer OAM cells are not passed to the ATM layer.

The content of the information field is "0110 1010" repeated 48 times.

10.5 Cell delineation and scrambling

10.5.1 Cell delineation and scrambling objectives

Cell delineation is the process which allows identification of the cell boundaries. The ATM cell header contains a HEC field which is used to achieve cell delineation.

The ATM signal is required to be self-supporting in the sense that it has to be transparently transported on every network interface without any constraints from the transmission systems used.

Scrambling shall be used to improve the security and robustness of the HEC cell delineation mechanism as described in subclause 10.5.1.1. In addition, it randomises the data in the information field for possible improvement of the transmission performance.

10.5.1.1 Cell delineation algorithm

Cell delineation shall be performed by using the correlation between the header bits to be protected (32 bits) and the relevant control bits (8 bits) introduced in the header by the HEC using a shortened cyclic code with generating polynomial $G(x) = x^8 + x^2 + x + 1$.

Figure 15 shows the state diagram of the HEC cell delineation method.

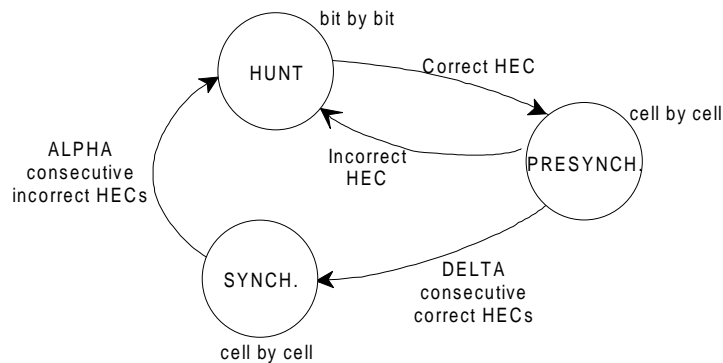

NOTE: The "correct HEC" means the header has no bit errors (syndrome is zero) and has not been corrected.

Figure 15: Cell delineation state diagram

The details of the state diagram given in figure 15 are described below:

- 1) in the HUNT state, the delineation process shall be performed by checking bit by bit for the correct HEC (i.e. syndrome equals zero) for the assumed header field. For the SDH based interface all 8 bits are used for acquiring cell delineation. Once such an agreement is found, it is assumed that one header has been found, and the process enters the PRESYNC state. When octet boundaries are available within the receiving Physical Layer prior to cell delineation as with the SDH-based interface, the cell delineation process may be performed octet by octet.
- 2) in the PRESYNC state, the delineation process shall be performed by checking cell by cell for the correct HEC. The process repeats until the correct HEC has been confirmed DELTA times consecutively and then the method enters the SYNC state. If an incorrect HEC is found, the process returns to the HUNT state. The total number of consecutive correct HEC require to move from the HUNT state to the SYNC state therefore is DELTA+1.
- 3) in the SYNC state the cell delineation will be assumed to be lost if an incorrect HEC is obtained ALPHA times consecutively.
- 4) Cells with correct HECs (or cell headers with single bit errors which are corrected) that are processed while the SYNC state shall be passed to the ATM layer. Cells with correct HECs that are checked while in the PRESYNC state may optionally be passed to the ATM layer, but only when

they are part of the DELTA consecutive correct HECs necessary for transition to the SYNC state. The cell associated with the first correct HEC (in the HUNT state) may also optionally be passed to the ATM layer in conjunction with the DELTA cells just mentioned. In any case, idle cells and Physical Layer OAM cells are not passed to the ATM layer.

The parameters ALPHA and DELTA shall be chosen to make the cell delineation process as robust and secure as possible while satisfying the performance specified in subclause 10.5.2.

Robustness against false misalignments due to bit errors depends on ALPHA.

Robustness against false delineation in the re-synchronisation process depends on the value of DELTA. For the SDH-based Physical Layer, ALPHA=7 and DELTA=6.

10.5.2 Cell delineation performance

Figures A.1 and A.2 of annex A give provisional information on the performance of the cell delineation algorithm described in subclause 10.5.1.1 in the presence of random bit errors, for various values of ALPHA and DELTA.

10.5.3 Scrambler operation

The following polynomial has been identified for the physical layer:

self synchronising scrambler $x^{43} + 1$.

This self synchronising scrambler polynomial has been selected to minimise the error multiplication (two) introduced by the self synchronised scrambler.

The operation of this scrambler in relation to the HEC cell delineation state diagram is as follows:

- the scrambler randomises the bits of the information field only (avoiding error multiplication in the header);
- during the five octets header the scrambler operation is suspended and the scrambler state retained;
- in the HUNT state the descrambler is disabled;
- in the PRESYNCH and SYNCH states the descrambler is enabled for a number of bits equal to the length of the information field, and again disabled for the following assumed header;
- at start up (e.g. at the power up or re-synchronisation following loss of signal), the first 43 bits of the payload of the first cell transmitted will be used to synchronise the scrambler and descrambler, and as a result the first cell will be corrupted.

11 UNI related OAM functions

The following OAM functions associated with the UNI have been identified and are described in ITU-T Recommendation I.610 [8]:

- 1) transmission and reception of maintenance signals (e.g. Alarm Indication Signal (AIS) and Remote Defect Indication (RDI) signal);
- 2) performance monitoring;
- 3) control communications provisions.

Some overhead capacity needs to be allocated to these functions.

11.1 Transmission overhead allocation

Transmission overhead allocation for the SDH Physical Layer functions (listed in table 1 of ITU-T Recommendation I.610 [8], with the amendments as given in I-ETS 300 404 [10]) is given in table 3. Use of these overheads (e.g. for frame alignment, AU pointer generation/interpretation, Bit Interleaved Parity (BIP) code calculation, etc.) shall be in accordance with specifications in ITU-T Recommendations G.708 [15] and G.709 [16] for the SDH Network Node Interface (NNI).

Table 3: SDH overhead octets allocation at B-UNI

Octet (note 4)	Function	Coding (NOTE 1)
STM section overhead A1, A2 J0 (note 8) B1 B2 H1, H2 H3 K2 (bits 6-8) M1(note 5)	Frame alignment Regenerator Section Trace Regenerator section error monitoring (NOTE 2) Multiplex section error monitoring AU-4 pointer, VC-4 Path AIS Pointer action Section AIS / section RDI (NOTE 7) Section error reporting (REI)	BIP-8 BIP-24 (155 520 kbit/s) BIP-96 (622 080 kbit/s) All 1s 111/110 B2 error count
VC path overhead J1 B3 C2 G1 (bits 1-4) G1 (bit 5)	Access Point ID/verification Path error monitoring Path signal label Path error reporting (REI) Path RDI (NOTE 6)	BIP-8 ATM cells (note 3) B3 error count 1

NOTE 1: Only octet coding relevant to OAM function implementation is listed.

NOTE 2: The use of B1 for regenerator section error monitoring across the UNI is application dependent and is therefore optional.

NOTE 3: Signal label code for ATM cell payload is "0001 0011" for VC.

NOTE 4: The bit numbering of table 3 is different from the conventions used in ITU-T Recommendation I.361 [6] but in accordance with ITU-T Recommendation G.709 [16].

NOTE 5: Using the notation of ITU-T Recommendation G.708 [15], the bits to be used are bits (2-8) of octet S (9,6,1) in the case of the interface at 155 520 kbit/s, and bits (2-8) of octet S (9,4,3) in the case of the interface at 622 080 kbit/s.

NOTE 6: Path RDI should also be used to indicate loss of cell delineation. The use of RDI to differentiate between defects in termination and adaptation function is for further study.

NOTE 7: The applicability of Multiplexer Section AIS (MS-AIS) at the B-UNI is for further study.

NOTE 8: The need of this J0 octet is for further study.

11.2 Maintenance signals

Two types of maintenance signals are defined for the physical layer to indicate the detection and location of a transmission failure. These signals are:

- AIS;
- RDI.

These signals are applicable at both the SDH section and path layers of the physical layer.

AIS is used to alert associated termination point in the direction of transmission that a failure has been detected and alarmed. RDI is used to alert associated termination point in the opposite direction of transmission that a failure has been detected. Path RDI alerts the path termination point in the opposite direction of transmission that a failure has occurred along the path. Path RDI shall also be used to indicate loss of cell delineation. Generation and detection of section and path AIS or RDI shall be in accordance with ITU-T Recommendation G.709 [16].

11.3 Transmission performance monitoring

Transmission performance monitoring across the UNI is performed to detect and report transmission errors. Performance monitoring is provided for the SDH section and for the path respectively, corresponding to maintenance flows F2 and F3 in figure 5 of ITU-T Recommendation I.610 [8].

At the SDH section (F2 flow), monitoring of the incoming signal is performed using the Bit Interleaved Parity 24 (BIP-24) or BIP-96 inserted into the B2 field (for the 155 520 kbit/s bit rates and 622 080 kbit/s respectively). Monitoring of the outgoing signal is performed using the Far End Block Error (REI). This error count, obtained from comparing the calculated BIP and the B2 value of the incoming signal at the far end, is inserted in a Z2 field and sent back: it reports to the near end section termination point about the error performance of its outgoing signal as REI.

Similar to the SDH section, at the SDH path (F3 flow), monitoring of the incoming signal is performed using the BIP-8 of the B3 octet. Monitoring of the outgoing signal is performed using the Path REI of bits 1-4 of the G1 octet.

Regenerator section monitoring (F1 flow) across the UNI is optional. If required, the incoming signal is monitored using the BIP-8 of the B1 octet. Capabilities in the SDH section overhead for monitoring the outgoing signal are not provided.

Further definitions are stated in ITU-T Recommendation G.708 [15].

11.4 Control communication

Section layer communication channels and order wires across the UNI are not required and are not provided.

12 Operational functions

12.1 Definition of signals at the interface

12.1.1 Signals defined in ITU-T Recommendation I.610 [8]

The following signals related to maintenance are defined below:

Indication of LOS, LOF, LOP and LCD are generated within the functional equipment. Path-AIS, path- RDI and section- RDI are signals transmitted/received across the B-UNI.

Loss of signal (LOS): LOS is considered to have occurred when the amplitude of the relevant signal has dropped below prescribed limits for a prescribed period.

Loss of frame (LOF): the interface detects a LOF when a number that is to be defined or more consecutive errored framing patterns have been received.

Loss of pointer (LOP): the interface detects a LOP when a valid pointer can not be obtained using the pointer interpretation rules described in ITU-T Recommendation G.783 [17].

MULTIPLEX SECTION Alarm Indication Signal (MS-AIS): MS-AIS is an STM-1 signal containing valid section overhead and a scrambled all-ones pattern for the remainder of the signal. On detecting LOS or LOF on the incoming signal, MS-AIS is generated by a regenerator within a time to be defined (typically some μ s). MS-AIS is detected as an all 1s in bits 6,7 and 8 of the K2 byte after descrambling.

PATH Alarm Indication Signal (P-AIS): AU-AIS is sent to alert equipment in the direction of transmission that a failure has been detected. P-AIS is an all ones signal in H1, H2, and H3 octets, as well as in the entire payload. On detecting a failure or MS-AIS, P-AIS is generated within a time to be defined (typically some μ s).

MULTIPLEX SECTION Far End Receive Failure (MS-RDI): MS-RDI alerts equipment in the opposite direction of transmission that a failure has been detected. On detecting LOS, LOF, or a MS-AIS on the incoming signal, MS-RDI is sent within a time to be defined (typically some μ s) by inserting the code "110" in bit positions 6, 7, and 8 of the K2 byte.

PATH Far End Receive Failure (P-RDI): P- RDI alerts the associated path terminating equipment that a failure in the direction of transmission has been declared along the STM Path. If LOS, LOF, LOP, LCD, MS-AIS, or AU-AIS are detected, P RDI is generated within a time to be defined (typically some μ s) by setting bit 5 in the path status byte, G1, to one.

12.1.2 Cell delineation signals

Out of Cell Delineation (OCD) - An OCD anomaly occurs, when the cell delineation process changes from SYNC state to HUNT state while in a working state (refer to Figure 15). An OCD anomaly terminates, when the PRESYNC to SYNC state transition occurs (refer to Figure 15) or ,when the OCD anomaly persists and the LCD maintenance state is entered (see below).

Loss of Cell Delineation (LCD)- An LCD defect occurs, when an OCD anomaly (see above) has persisted for x ms. An LCD defect terminates, when the cell delineation process (refer to Figure 15) enters and remains in the SYNC state for x continuous milliseconds. The value of x for other interface types is for further study.

NOTE: For implementations where the value of x is zero, the conditions for entering OCD and LCD signal states are identical and are equivalent to the signal LOC (loss of cell delineation) used in earlier versions of ITU-T Recommendation I.432 [7].

12.2 Definitions of state tables at network and user sides

The user side and network side of the interface have to inform each other of the layer 1 states in relation to the different defects that could be detected.

For the purpose, two state tables are defined, one at the user side and one at the network side. States at the user side (F states) are defined in subclause 12.2.1 and states at the network side (G states) are defined in subclause 12.2.2. The state tables are defined in subclause 12.2.4.

Fault conditions FC1 to FC4 that could occur at the network side or between the network side and user side are defined in figure 15. These fault conditions directly affect the F and G states. Information on these fault conditions is exchanged between the user and network sides in the form of signals defined in subclause 12.1.

NOTE 1: Only stable states needed for OAM of the user and the network side of the interface (system reactions, user and network relevant information) are defined. The transient states relative to the detection of the error information are not taken into account, except for power on/off transient states F6 and G13.

NOTE 2: The user does not need to know where a failure is located in the network. The user shall be informed on the availability and the continuity of the layer 1 service.

NOTE 3: The user has all information relative to the performance associated with each direction of its adjacent section. The supervision of the quality of this section is the user's responsibility.

12.2.1 Layer 1 states on the user side of the interface

FO state: loss of power on the user side

- in general, the TE can neither transmit nor receive signals.

F1 state: operational state

- network timing and layer 1 service is available;
- the user side transmits and receives operational frames.

F2 state: fault condition No. 1

- this fault state corresponds to the fault condition FC1;
- network timing is available at the user side;
- the user side transmits operational frames;
- the user side receives frame containing P-RDI indication and not MS-RDI.

F3 state: fault condition No. 2

- this fault state corresponds to any combination of FC2 with FC1, FC3 and FC4;
- network timing may no longer be available through the link;
- the user side detects LOS, LOF;
- the user side transmits frames with MS-RDI and P-RDI.

F4 state:

- this fault state corresponds to fault condition FC3, or FC1 and FC3;
- network timing may no longer be available through the link;
- the user side detects P-AIS, LOP, or LOC;
- the user side transmits frames containing P-RDI indication.

F5 state: fault condition No. 4

- this fault state corresponds to the fault condition FC4 or FC1 and FC4;
- network timing is available at the user side;
- the user side transmits operational frames;
- the user side receives frames containing MS-RDI and P-RDI indications.

F6 state:

- this fault corresponds to fault conditions FC3 and FC4 or FC3 and FC4 and FC1;
- network timing may no longer be available through the link;
- the user side receives frames containing MS-RDI and P-AIS or LCD and MS-RDI and P-RDI or LOP and MS-RDI;
- the user side transmits frames containing P-RDI.

F7 state: power on state

- this is a transient state and the user side may change the state after detection of the signal received.

12.2.2 Layer 1 states at the network side of the interface

GO state: loss of power on the Network side

- in general, the B-NT1 can neither transmit nor receive any signal.

G1 state: operational state

- the network timing and layer 1 service is available;
- the network side transmits and receives operational frames.

G2 state: fault condition No. 1

- this fault state corresponds to the fault condition FC1;
- network timing is provided to the user side;
- the path terminating equipment within the access network detects LOS, LOF, LOP, LCD, or receives MS-AIS or P-AIS (see note);
- the network side transmits frames containing P-RDI indication and not MS-RDI.

G3 state: fault condition No. 2

- this fault state corresponds to the fault condition FC2;
- network timing may no longer be available through the link;
- the network side transmits operational frames;
- the network side receives frames containing MS-RDI and P-RDI indications.

G4 state: fault condition No. 3

- this fault state corresponds to the fault condition FC3;
- network timing may no longer be available through the link;
- the B-NT1 detects LOS or LOF or LOP or receives MS-AIS or P-AIS (see note) from the access network;
- the network side transmits P-AIS;
- the network side receives frames containing P-RDI indication.

G5 state:

- this fault state corresponds to the fault condition FC4 or FC2 and FC4;
- the network side detects LOS or LOF;
- the network side transmits frames containing MS-RDI and P-RDI indication to the user side.

G6 state:

- this fault state corresponds to fault conditions FC1 and FC2;
- network timing may no longer be available through the link;
- the network side transmits frames containing P-RDI indication;
- the B-NT1 receives MS-RDI and P-RDI indications from the user side and the path terminating equipment detects LOS, LOF, LOP, LCD, or receives MS-AIS or P-AIS (note).

G7 state:

- this fault state corresponds to fault conditions FC1 and FC3;
- network timing may no longer be available through the link;
- the network side transmits frames containing P-AIS indication;
- the network side receives frames containing P-RDI.

G8 state:

- this fault state corresponds to fault conditions FC1 and FC4 or FC1 and FC2 and FC4;
- the network side transmits frames containing MS-RDI and P-RDI indications to the user side.

G9 state:

- this fault state corresponds to fault conditions FC2 and FC3;
- network timing may no longer be available through the link;
- the network side transmits frames containing P-AIS;

- the network side receives frames containing MS-RDI and P-RDI indications.

G10 state:

- this fault state corresponds to fault conditions FC3 and FC4 or FC2 and FC3 and FC4;
- network timing may no longer be available through the link;
- the network side transmits frames containing P-AIS and MS-RDI indications to the user side.

G11 state:

- this fault state corresponds to fault conditions FC1 and FC2 and FC3;
- network timing may no longer be available through the link;
- the network side transmits P-AIS to the user side;
- the network side receives frames containing MS-RDI and P-RDI indications.

G12 state:

- this fault state corresponds to fault conditions FC1 and FC3 and FC4 or FC1 and FC2 and FC3 and FC4;
- network timing may no longer be available through the link;
- the network side transmits frames containing P-AIS and MS-RDI indications to the user side.

G13 state: power on state

- this is a transient state and the network side may change the state after detection of the signal received.

NOTE: A P-AIS is not received if the portion between B-NT1 and path termination equipment is build of only one single Multiplex Section (as shown in figure 16).

12.2.3 Definition of primitives

The following primitives should be used between the physical media dependent layer and the management entity (Management Physical Header (MPH) primitives) and the upper layer (Physical Header (PH) primitives), respectively:

MPH-AI	MPH ACTIVATE INDICATION (is used as error recovery and initialisation information);
MPH-DI	MPH DEACTIVATE INDICATION;
MPH-EIn	MPH ERROR INDICATION with parameter n (n defines the failure condition relevant to the reported error);
MPH-CIn	MPH CORRECTION INDICATION with parameter n (n defines the failure condition relevant to the reported recovery);
PH-AI	PH ACTIVE INDICATION;
PH-DI	PH DEACTIVE INDICATION.

12.2.4 State tables

Operational functions are defined in table 4 for the layer 1 states at the user side of the interface and in table 5 for the network side.

General information for the state table matrix consideration:

Explanations of the symbols used in the tables 4 and 5:

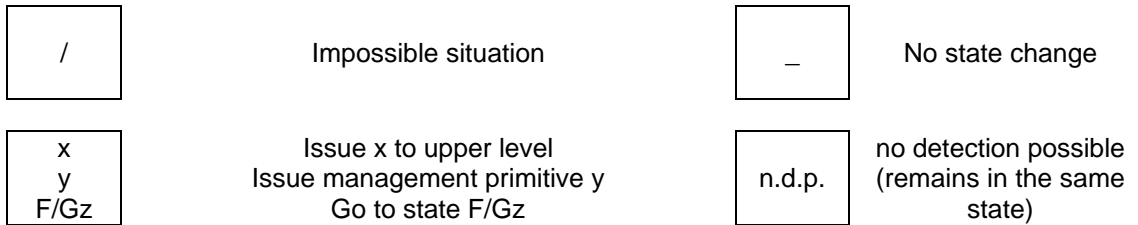

Location of fault conditions:

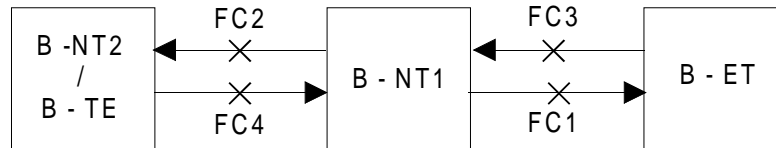

Fault condition	Definition
FC1	Fault in the upstream direction in access digital section
FC2	Fault in the downstream direction of the interface
FC3	Fault in the downstream direction in access digital section
FC4	Fault in the upstream direction of the interface

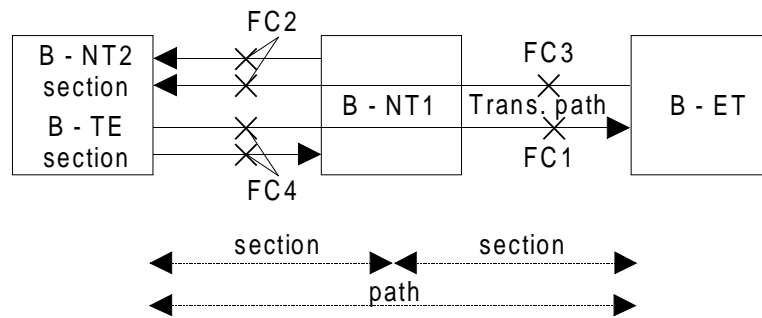

Figure 16: Fault conditions and operational span of section path maintenance signals

Table 4: F-State Table: physical layer 1 state matrix at the user side (note 1)

	Initial state	F0	F1	F2	F3	F4	F5	F6	F7
Definition of the states	Operational condition or fault condition	Power off at user side	Operational	FC1	FC2 fault conditions (NOTE 4)	FC3 or FC1&FC3	FC4 or FC1&FC4	FC3&FC4 or FC1&FC3&FC4	Power on at user side
	Signal transmitted by user towards interface	No signal	Normal operational frames	Normal operational frames	Frames with MS- RDI & P- RDI	Frames with P-RDI	Normal operational frames	Frames with P-RDI	No signal
New appearing event, detected at receiving side	Loss of power or powerdown mode at user side	/	PH-DI MPH-EI0 F0	MPH-EI0 F0	MPH-EI0 F0	MPH-EI0 F0	MPH-EI0 F0	MPH-EI0 F0	MPH-EI0 F0
	Return of power at user side	F7	/	/	/	/	/	/	/
	Normal operational frames from network side	/	-	PH-AI MPH-AI F1	PH-AI MPH-AI F1	PH-AI MPH-AI F1	PH-AI MPH-AI F1	PH-AI MPH-AI F1	PH-AI MPH-AI F1
	Reception of P-RDI (FC1)	/	PH-DI MPH-EI1 F2	-	ndp	-	-	-	MPH-EI1 F2
	LOS or LOF (FC2) (NOTE 2)	/	PH-DI MPH-EI2 F3	MPH-EI2 F3	-	MPH-EI2 F3	MPH-EI2 F3	MPH-EI2 F3	MPH-EI2 F3
	LOC or LOP or P-AIS (FC3) or (FC1&FC3) (NOTE 3)	/	PH-DI MPH-EI3 F4	MPH-EI3 F4	ndp	-	MPH-EI3 F4	-	MPH-EI3 F4
	Reception of MS-RDI & P-RDI (FC4)	/	PH-DI MPH-EI4 F5	MPH-EI4 F5	ndp	MPH-EI4 F5	-	-	MPH-EI4 F5
P-AIS & MS-RDI or LCD & MS-RDI & P-RDI or LOP & MS-RDI (FC3&FC4)	/	PH-DI MPH-EI3 MPH-EI4 F6	MPH-EI3 MPH-EI4 F6	ndp	MPH-EI4 F6	MPH-EI3 F6	-	MPH-EI3 MPH-EI4 F6	

NOTE 1: If the access point ID is used, the access point ID mismatch will be a path related failure as LOP or LCD. In this table "LCD" will be substituted by "LCD or access point ID mismatch".

NOTE 2: When FC2 occurs, other fault conditions (FC1 or FC3 or FC4) cannot be detected but they may occur simultaneously.

NOTE 3: When FC3 occurs, FC1 (P-RDI) cannot be detected but it may occur simultaneously.

NOTE 4: The user side cannot distinguish among FC2, FC1&FC2, FC2&FC3, FC2&FC4, FC1&FC2&FC3, FC1&FC2&FC4, FC2&FC3&FC4, or FC1&FC2&FC3&FC4.

Table 5: G-state table: physical layer 1 state matrix at the network side

	Initial state	G0	G1	G2	G3	G4	G5	G6	G7	G8	G9	G10	G11	G12	G13
Definition of the states	Operation condition or failure condition	Power off at NT1	Operational	FC1	FC2	FC3	FC4 or FC2 & FC4	FC1 & FC2	FC1 & FC3	FC1 & FC4 or FC1 & FC2 & FC4	FC2 & FC3	FC3 & FC4 or FC2 & FC3 & FC4	FC1 & FC2 & FC3	FC1 & FC3 & FC4 or FC1 & FC2 & FC3 & FC4	Power on at NT1
	Signal transmitted towards interface	No signal	Normal operational signal	Signal with P-RDI	Normal operational signal	Signal with P-AIS	Signal with MS-RDI & P-RDI	Signal with P-RDI	Signal with P-AIS	Signal with MS-RDI & P-RDI	Signal with P-AIS	Signal with P-AIS & MS-RDI	Signal with P-AIS	Signal with P-AIS & MS-RDI	No signal
New detected event	Loss of power or powerdown mode of NT1	-	PH-DI MPH-EI0 G0	MPH-EI0 G0	MPH-EI0 G0	MPH-EI0 G0	MPH-EI0 G0	MPH-EI0 G0	MPH-EI0 G0	MPH-EI0 G0	MPH-EI0 G0	MPH-EI0 G0	MPH-EI0 G0	MPH-EI0 G0	MPH-EI0 G0
	Return of power at NT1	MPH-CI0 G13	/	/	/	/	/	/	/	/	/	/	/	/	/
	Normal operational frames	/	-	PH-AI MPH-AI G1	PH-AI MPH-AI G1	PH-AI MPH-AI G1	PH-AI MPH-AI G1	PH-AI MPH-AI G1	PH-AI MPH-AI G1	PH-AI MPH-AI G1	PH-AI MPH-AI G1	PH-AI MPH-AI G1	PH-AI MPH-AI G1	PH-AI MPH-AI G1	PH-AI MPH-AI G1
New appearing event	Internal network failure FC1	/	PH-DI MPH-EI1 G2	-	MPH-EI1 G6	MPH-EI1 G7	MPH-EI1 G8	-	-	-	MPH-EI1 G11	MPH-EI1 G12	-	-	MPH-EI1 G2
	Reception of MS-RDI & P-RDI (FC2)	/	PH-DI MPH-EI2 G3	MPH-EI2 G6	-	MPH-EI2 G9	n.d.p.	-	MPH-EI2 G11	n.d.p.	-	n.d.p.	-	n.d.p.	MPH-EI2 G3
	Internal network failure FC3 (NOTE)	/	PH-DI MPH-EI3 G4	MPH-EI3 G7	MPH-EI3 G9	-	MPH-EI3 G10	MPH-EI3 G11	-	MPH-EI3 G12	-	-	-	-	MPH-EI3 G4
	LOS or LOF (FC4)	/	PH-DI MPH-EI4 G5	MPH-EI4 G8	MPH-EI4 G5	MPH-EI4 G10	-	MPH-EI4 G8	MPH-EI4 G12	-	MPH-EI4 G10	-	MPH-EI4 G12	-	MPH-EI4 G5
Dis-appearing FC	FC1	/	/	MPH-CI1 G1	/	/	/	MPH-CI1 G3	MPH-CI1 G4	MPH-CI1 G5	/	/	MPH-CI1 G9	MPH-CI1 G10	/
	FC2	/	/	/	MPH-CI2 G1	/	-	MPH-CI2 G2	/	-	MPH-CI2 G4	-	MPH-CI2 G7	/	/
	FC3	/	/	/	/	MPH-CI3 G1	/	/	MPH-CI3 G2	/	MPH-CI3 G3	MPH-CI3 G5	MPH-CI3 G6	MPH-CI3 G8	/
	FC4	/	/	/	/	/	MPH-CI4 G3	/	/	MPH-CI4 G6	/	MPH-CI4 G9	/	MPH-CI4 G11	/
NOTE:	If FC3 represents a path related fault condition (e.g. LCD), the consequent reaction is not applicable for the G-state table, because this failure cannot be recognised at the network side. Therefore, no state change will occur.														

Annex A (informative): Impact of random bit errors on cell delineation performance

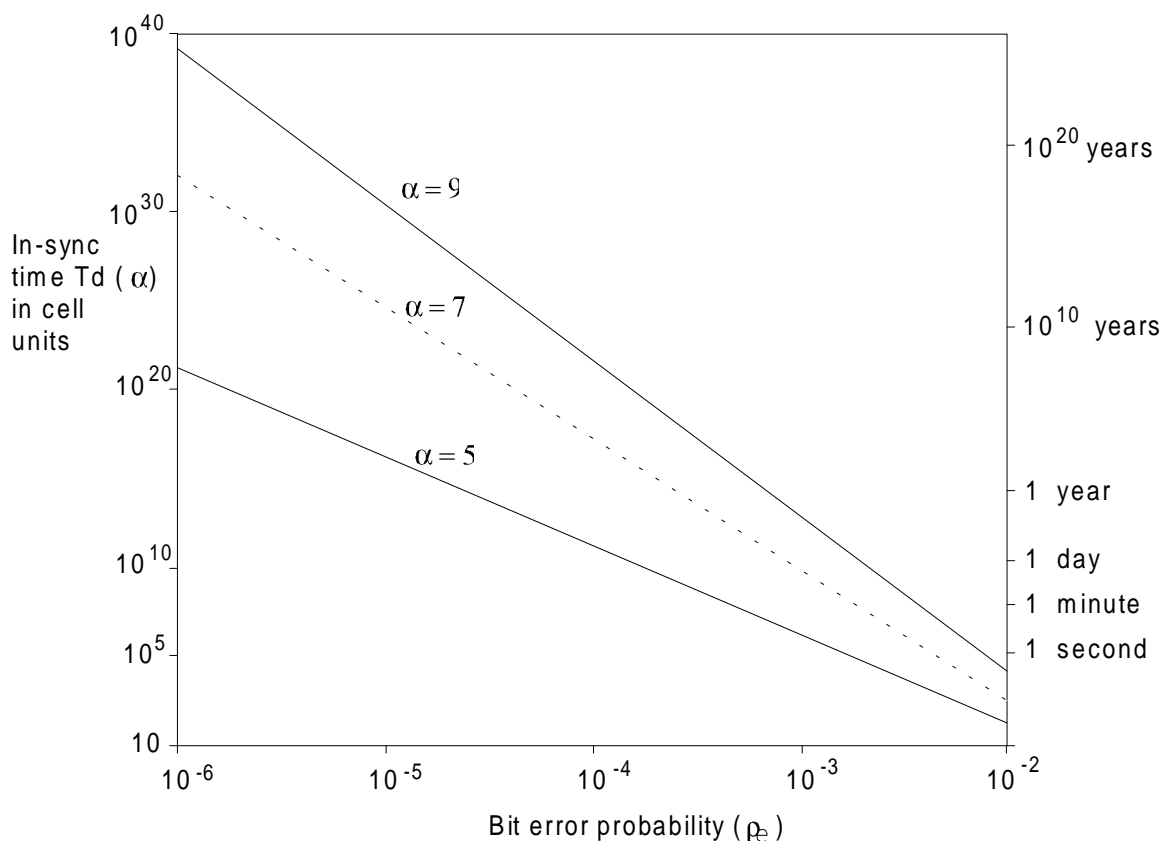

Figure A.1: In-sync time vs. bit error probability ($T_d(\alpha)$ vs. ρ_e)

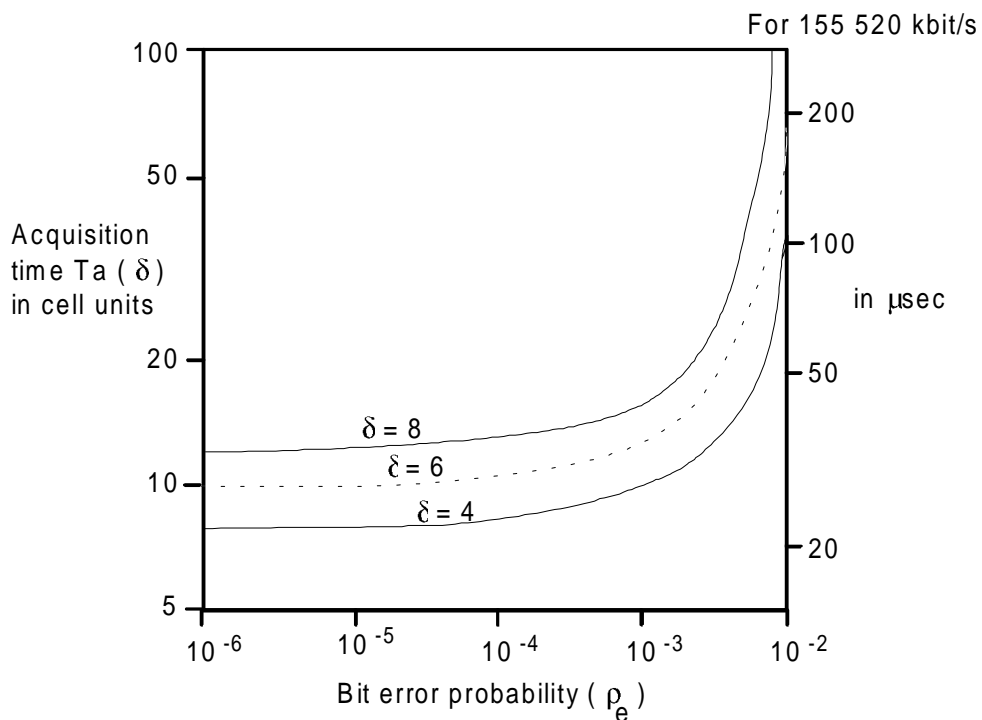

Figure A.2: Acquisition time vs. bit error probability ($T_a(\delta)$ vs. ρ_e)

Annex B (informative): Bibliography

ITU-T Recommendation I.431: " Primary rate user-network interface - Layer 1 specification".

History

Document history	
February 1995	First Edition
May 1996	Public Enquiry PE 106: 1996-05-20 to 1996-09-13