



EUROPEAN
TELECOMMUNICATION
STANDARD

DRAFT
pr **ETS 300 299**

June 1996

Second Edition

Source: ETSI TC-TM

Reference: RE/TM-03030

ICS: 33.040.20

Key words: B-ISDN, ISDN, UNI, ATM, interface, access

**Broadband Integrated Services Digital Network (B-ISDN);
Cell based user network access
for 155 520 kbit/s and 622 080 kbit/s;
Physical layer interfaces for B-ISDN applications**

ETSI

European Telecommunications Standards Institute

ETSI Secretariat

Postal address: F-06921 Sophia Antipolis CEDEX - FRANCE

Office address: 650 Route des Lucioles - Sophia Antipolis - Valbonne - FRANCE

X.400: c=fr, a=atlas, p=etsi, s=secretariat - **Internet:** secretariat@etsi.fr

Tel.: +33 92 94 42 00 - Fax: +33 93 65 47 16

*

Copyright Notification: No part may be reproduced except as authorized by written permission. The copyright and the foregoing restriction extend to reproduction in all media.

© European Telecommunications Standards Institute 1996. All rights reserved.

Contents

Foreword		7
1	Scope	9
2	Normative references	9
3	Definitions and abbreviations	10
3.1	Definitions	10
3.2	Abbreviations	10
4	Reference configuration at the user-network interface	11
4.1	Functional groups and reference points	11
4.2	Examples of physical realizations	11
4.3	Basic characteristics of the interfaces at T_B and S_B reference points	15
4.3.1	Characteristics of the interfaces at 155 520 kbit/s	15
4.3.1.1	Interface at the T_B reference point	15
4.3.1.2	Interface at the S_B reference point	15
4.3.1.3	Relationship between interfaces at S_B and T_B	15
4.3.2	Characteristics of the interfaces at 622 080 kbit/s	15
4.3.2.1	Interface at T_B reference point	15
4.4	Relationship between ISDN interfaces	15
4.5	Functional groups characteristics	15
4.5.1	Network termination 1 for B-ISDN	15
4.5.2	Network termination 2 for B-ISDN	16
4.5.3	Terminal equipment for B-ISDN	16
4.5.3.1	Terminal equipment type 1 for B-ISDN	16
4.5.3.2	Terminal equipment type 2 for B-ISDN	17
4.5.4	Terminal adapter for B-ISDN	17
5	User network interface specifications	17
5.1	Interface location with respect to reference configuration	17
5.2	Interface location with respect to the wiring configuration	17
6	Service and layering aspects of the physical layer	18
6.1	Services provided to the ATM-layer	18
6.2	Service primitives exchanged with the ATM layer	18
6.3	Sublayering of the physical layer	18
7	Physical medium characteristics of the user network interface at 155 520 kbit/s	18
7.1	Characteristics of the interface at the T_B and S_B reference points	18
7.1.1	Bit rate and interface symmetry	18
7.1.2	Physical characteristics	18
7.1.2.1	Electrical interface	18
7.1.2.1.1	Interface range	18
7.1.2.1.2	Transmission medium	18
7.1.2.1.3	Electrical parameters at interface points I_a and I_b	19
7.1.2.1.4	Electrical connectors	19
7.1.2.1.5	Line coding	19
7.1.2.1.6	EMC/EMI requirements	19
7.1.2.2	Optical interface	21
7.1.2.2.1	Attenuation range	21
7.1.2.2.2	Transmission medium	21
7.1.2.2.3	Optical parameters	21
7.1.2.2.3.1	Line coding	21
7.1.2.2.3.2	Operating wavelength	21
7.1.2.2.3.3	Input and output port characteristics	21

		7.1.2.2.4	Optical connectors	22
		7.1.2.2.5	Safety requirements	22
	7.1.2.3		Jitter and wander	22
8	Physical medium characteristics of the UNI at 622 080 kbit/s			22
	8.1	Characteristics of the interface at the T _B and S _B reference points		22
		8.1.1	Bit rate and interface symmetry	22
		8.1.2	Physical characteristics	22
			8.1.2.1 Attenuation range	22
			8.1.2.2 Transmission medium	23
			8.1.2.3 Optical parameters	23
			8.1.2.3.1 Line coding	23
			8.1.2.3.2 Operating wavelength	23
			8.1.2.3.3 Input and output port characteristics	23
		8.1.2.4	Optical connectors	23
		8.1.2.5	Safety requirements	23
		8.1.2.6	Jitter and wander	23
9	Power feeding			24
	9.1	Provision of power		24
	9.2	Power available at B-NT1		24
	9.3	Feeding voltage		24
	9.4	Safety requirements		24
10	Functions provided by the transmission convergence sublayer			25
	10.1	Transfer capability		25
		10.1.1	Interface at 155 520 kbit/s	25
		10.1.2	Interface at 622 080 kbit/s	25
	10.2	Physical layer aspects		25
		10.2.1	Timing	25
		10.2.2	Interface structure for 155 520 kbit/s and 622 080 kbit/s	25
	10.3	Header Error Control		25
		10.3.1	Header Error Control functions	25
		10.3.2	Header Error Control (HEC) sequence generation	28
	10.4	Idle cells		28
	10.5	Cell delineation and scrambling		29
		10.5.1	Cell delineation and scrambling objectives	29
			10.5.1.1 Cell delineation algorithm	29
		10.5.2	Cell delineation performance	30
		10.5.3	Scrambler operation	30
			10.5.3.1 Distributed sample scrambler (31st order)	30
			10.5.3.2 Transmitter operation	30
			10.5.3.3 Receiver operation	31
			10.5.3.4 State transition diagram and mechanism	32
11	UNI related OAM functions			33
	11.1	Transmission overhead allocation		33
	11.2	OAM cell identification		33
	11.3	Allocation of OAM functions in information field		34
	11.4	Maintenance signals		37
	11.5	Transmission performance monitoring		37
	11.6	Control communication		38
12	Operational functions			38
	12.1	Description of signals at the interface		38
		12.1.1	Signals defined in Recommendation I.610	38
		12.1.2	Cell Delineation signals	38
	12.2	Definitions of state tables at network and user sides		39
		12.2.1	Layer 1 states on the user side of the interface	39
		12.2.2	Layer 1 states at the network side of the interface	40
		12.2.3	Definition of primitives	42
		12.2.4	State tables	43

Annex A (informative): Impact of random bit errors on cell delineation performance 46

Annex B (informative): Distributed sample scrambler descrambler implementation example..... 47

History..... 49

Blank page

Foreword

This draft second edition European Telecommunication Standard (ETS) has been produced by the Transmission and Multiplexing (TM) Technical Committee of the European Telecommunications Standards Institute (ETSI), and is now submitted for the Public Enquiry phase of the ETSI standards approval procedure.

This ETS defines the cell based user network access physical layer interfaces to be applied to the T_B , S_B reference points of the reference configurations of the Broadband Integrated Services Digital Network (B-ISDN) User-Network Interface (UNI) at 155 520kbit/s and 622 080 kbit/s, for B-ISDN applications. It addresses separately the Physical Media Dependant (PMD) and Transmission Convergence (TC) sublayers used at these interfaces and addresses also the implementation of UNI related Physical Layer Operations And Maintenance (OAM) functions.

This ETS takes into account the recommendations given in ITU-T Recommendation I.413 [7] and Draft ITU-T Recommendation I.432.1 [8].

Proposed transposition dates	
Date of latest announcement of this ETS (doa):	3 months after ETSI publication
Date of latest publication of new National Standard or endorsement of this ETS (dop/e):	6 months after doa
Date of withdrawal of any conflicting National Standard (dow):	6 months after doa

Blank page

1 Scope

This draft second edition European Telecommunication Standard (ETS) defines the physical layer interface to be applied to the S_B and T_B reference points of the reference configurations of the Broadband Integrated Services Digital Network (B-ISDN) cell based User-Network Interface (UNI) at 155 520 kbit/s and 622 080 kbit/s. It addresses separately the Physical Media Dependant (PMD) and Transmission Convergence (TC) sublayers used at these interfaces, and address also the implementation of UNI related physical layer OAM functions.

The selection of the physical medium for the interfaces at the S_B and T_B reference points should take into account that optical fibre is agreed as the preferred medium to be used to cable customer equipment. However, in order to allow the use of existing cabling of customer equipment, other transmission media (e.g. twisted pairs and coaxial cables) should not be precluded. Also, implementations should allow terminal interchangeability.

This ETS reflects in its structure and content the desire to take care of such early configurations and introduces a degree of freedom when choosing a physical medium at the physical layer.

2 Normative references

This ETS incorporates by dated and undated reference, provisions from other publications. These normative references are cited at the appropriate places in the text and the publications are listed hereafter. For dated references, subsequent amendments to or revisions of any of these publications apply to this ETS only when incorporated in it by amendment or revision. For undated references the latest edition of the publication referred to applies.

- [1] ITU-T Recommendation G.652: "Characteristics of a single-mode optical fibre cable".
- [2] ETS 300 166: "Transmission and Multiplexing (TM); Physical and electrical characteristics of hierarchical digital interfaces for equipment using the 2048 kbit/s - based plesiochronous or synchronous digital hierarchies".
- [3] ETS 300 232: "Transmission and Multiplexing (TM); Optical interfaces for equipments and systems relating to the Synchronous Digital Hierarchy [ITU-T Recommendation G.957 (1993) modified]".
- [4] ITU-T Recommendation I.113: "Vocabulary of terms for broadband aspects of ISDN".
- [5] ITU-T Recommendation I.321: "B-ISDN protocol reference model and its application".
- [6] ITU-T Recommendation I.361 (1995): "B-ISDN ATM layer specification".
- [7] ITU-T Recommendation I.413 (1993): "B-ISDN user-network interface".
- [8] Draft ITU-T Recommendation I.432.1 (1995): "B-ISDN user-network interface - Physical layer specification for 155 520 kbit/s and 622 080 kbit/s".
- [9] ITU-T Recommendation I.610 (1995): "B-ISDN operation and maintenance principles and functions".
- [10] ITU-T Recommendation X.200: "Information technology - Open Systems Interconnection - Basic reference model: The basic model".
- [11] I-ETS 300 404: "Broadband Integrated Services Digital Network (B-ISDN); B-ISDN Operation And Maintenance (OAM) principles and functions".
- [12] IEC Publication 825-1: "Safety of laser products: Part 1: Equipment classification requirements and user's guide".

- [13] IEC Publication 950: "Safety of information technology equipment, including electrical business equipment".
- [14] ITU-T Recommendation G.825: "The control of jitter and wander within digital networks which are based on the synchronous digital hierarchy (SDH)".
- [15] ITU-T Recommendation G.958: "Digital line systems based on the synchronous digital hierarchy for use on optical fibre cables".
- [16] ITU-T Recommendation G.826: "Error performance parameters and objectives for international, constant bit rate digital paths at or above the primary rate".

3 Definitions and abbreviations

3.1 Definitions

For the purposes of this ETS, the definitions given in ITU-T Recommendation I.113 [4] apply, in particular for the definitions of **idle cell**, **valid cell** and **invalid cell**. In addition, the following definition applies:

to be defined: These items or values are not yet specified.

3.2 Abbreviations

For the purposes of this ETS, the following abbreviations apply:

AIS	Alarm Indication Signal
ATM	Asynchronous Transfer Mode
BER	Bit Error Rate
B-ISDN	Broadband Integrated Services Digital Network
B-NT	B-ISDN Network Termination
B-TA	B-ISDN Terminal Adaptor
B-TE	B-ISDN Terminal Equipment
BIP	Bit Interleaved Parity
CATV	Category 5
CLP	Cell Loss Priority
CMI	Coded Mark Inversion
CRC	Cyclic Redundancy Check
DSS	Distrited Sample Scrambler
HEC	Header Error Control
ISDN	Integrated Services Digital Network
LAN	Local Area Network
LCD	Loss of Cell Delineation
LOM	Loss of Maintenance cell
LOS	Loss of Signal
NNI	Network Node Interface
MA	Medium Adaptor
MPH	Management Physical Header
NRZ	Non Return to Zero
OAM	Operation And Maintenance
OSI	Open Systems Interconnection
PH	Physical Header
PM	Physical Medium
p.p.m	parts per million
PRBS	Pseudo-Random Binary Sequence
RDI	Remode Defect Indication
STI	Surface Transfer Impedance
TC	Transmission Convergence
TFV	Terminal Failure Voltage
UNA	User-Network Access
UNI	User-Network Interface
TFV	Terminal Failure Voltage

4 Reference configuration at the user-network interface

4.1 Functional groups and reference points

The reference configurations defined for Integrated Services Digital Network (ISDN) basic access and primary access are considered general enough to be applicable to all aspects of the B-ISDN accesses.

Figure 1 shows the B-ISDN reference configurations which contain the following:

- functional groups: B-NT1, B-NT2, B-TE1, TE2, B-TE2, and B-TA;
- reference points: T_B , S_B and R.

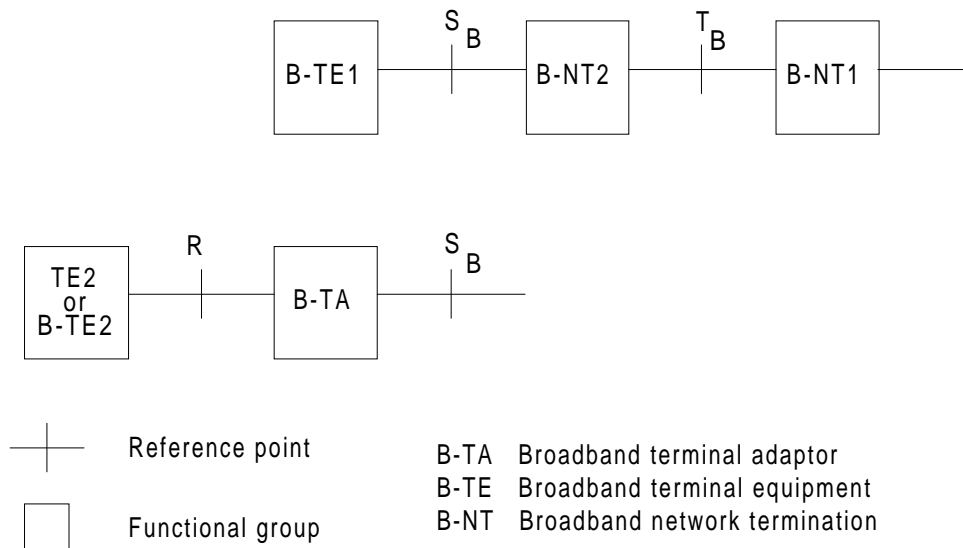

Figure 1: B-ISDN reference configurations

In order to clearly illustrate the broadband aspects, the notations for reference points and for functional groups with broadband capabilities are appended with the letter B (e.g. B-NT1, T_B). The broadband functional groups are equivalent to the functional groups defined in ISDN. Interfaces at the R reference point may or may not have broadband capabilities.

Interfaces at reference points S_B and T_B will be standardized. These interfaces will support all ISDN services.

4.2 Examples of physical realizations

Figure 2 gives examples of physical configurations illustrating combinations of physical interfaces at various reference points. The examples cover configurations that could be supported by standardized interfaces at reference points S_B and T_B . Other configurations may also exist. For example, physical configurations of B-NT2 may be distributed, or use shared medium, to support Local Area Network (LAN) emulation and other applications.

Figure 3 illustrates possible physical configurations, but does not preclude alternative configurations. Whether a single interface at the S_B reference point can cover different configurations, as illustrated in figure 3, is for further study.

Figure 2 is subdivided into separate items as follows:

- figures 2a) and 2b) show separate interfaces at the S_B and T_B reference points;
- figures 2c) and 2d) show an interface at S_B but not at T_B ;
- figures 2e) and 2f) show an interface at T_B but not at S_B ;
- figures 2g) and 2h) show separate interfaces at S, S_B and T_B ;
- figures 2i) and 2j) show interfaces at S_B and T_B which are coincident.

Additionally, figures 2b), 2d), 2f), 2h) and 2j) show an interface at reference point R.

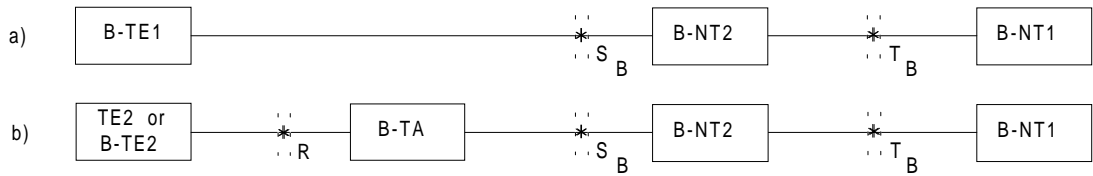

Configurations where B-ISDN physical interfaces occur at reference points S_B and T_B.

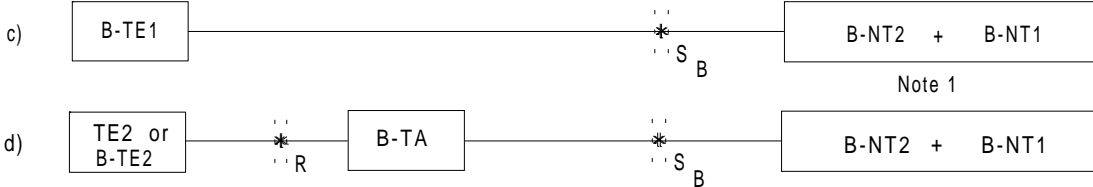

Configurations where B-ISDN physical interfaces occur at reference point S_B only.

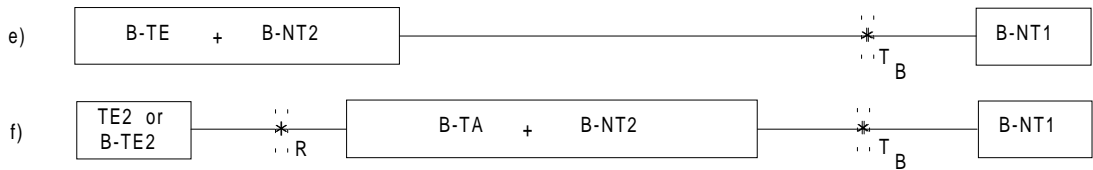

Configurations where B-ISDN physical interfaces occur at reference point T_B only.

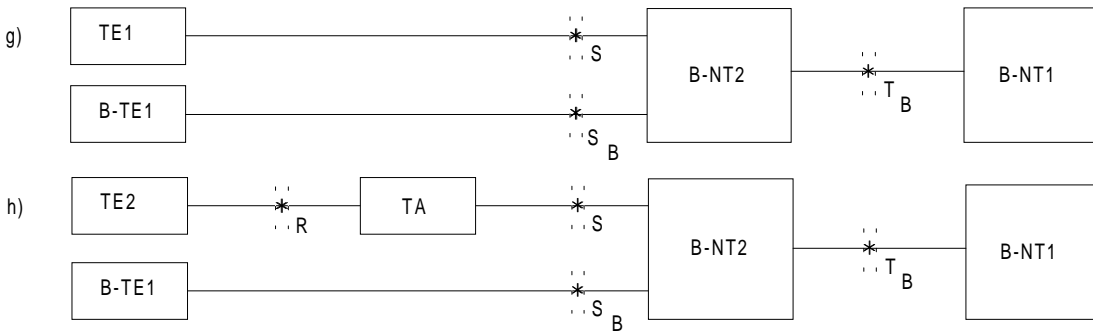

Configurations where B-ISDN and ISDN physical interfaces occur at reference points S, S_B and T_B.

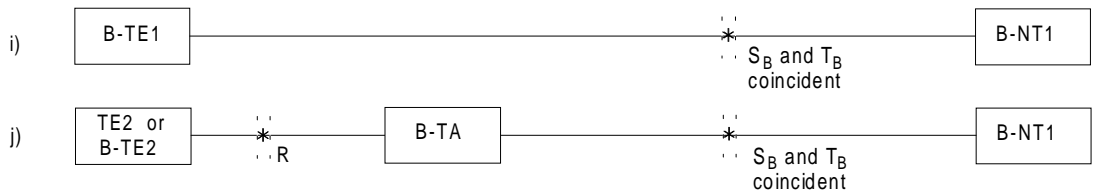

Configurations where a single B-ISDN physical interface occurs at a location where both reference points S_B and T_B coincide.



NOTE: The needed for an access to a T_B reference point "between B-NT1 and B-NT2" is for further study.

Figure 2: Examples of physical configurations for broadband user applications

a) centralised B-NT2 configuration:

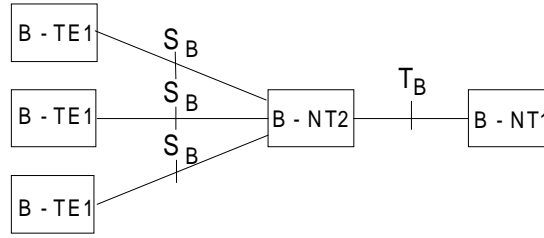

b) distributed B-NT2 configurations:

b1) generic configuration

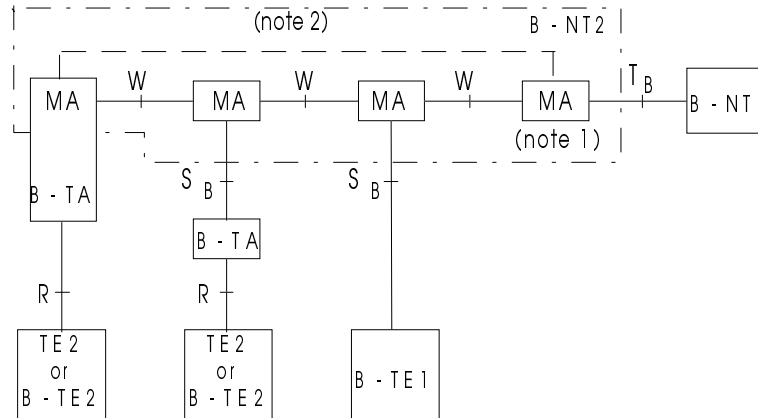

b2) physical configurations

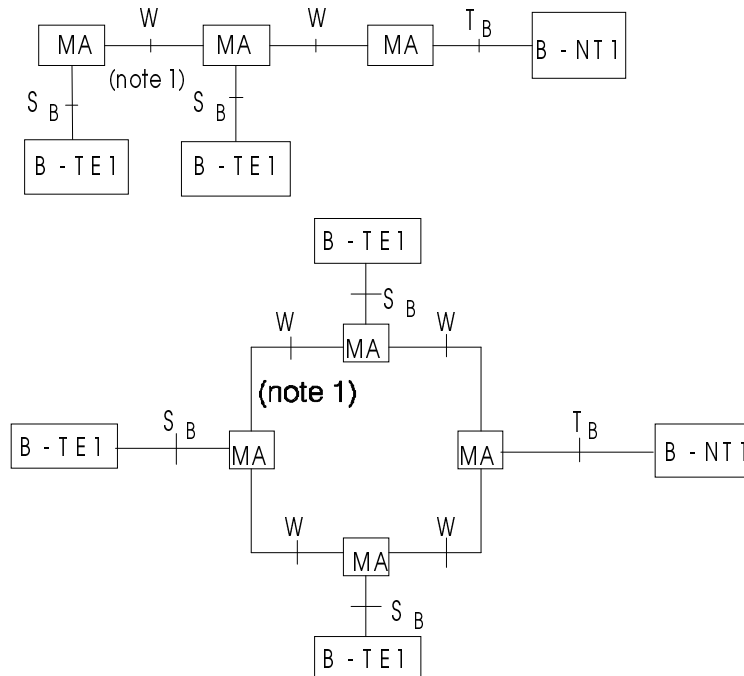
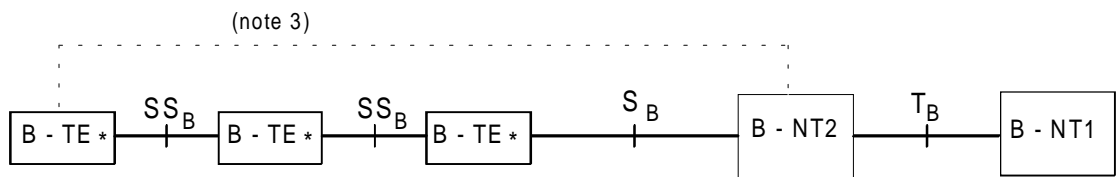

Figure 3: Examples of physical configurations for multipoint applications (continued)

c) multi-access B-TE configurations:

c1) generic configurations (note 7)



c2) physical configurations

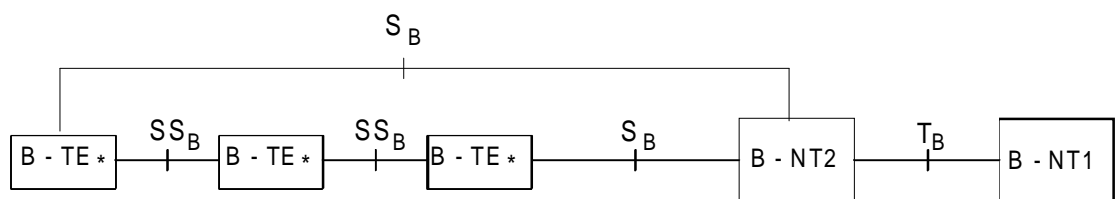
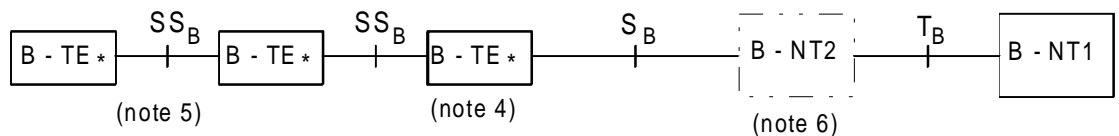
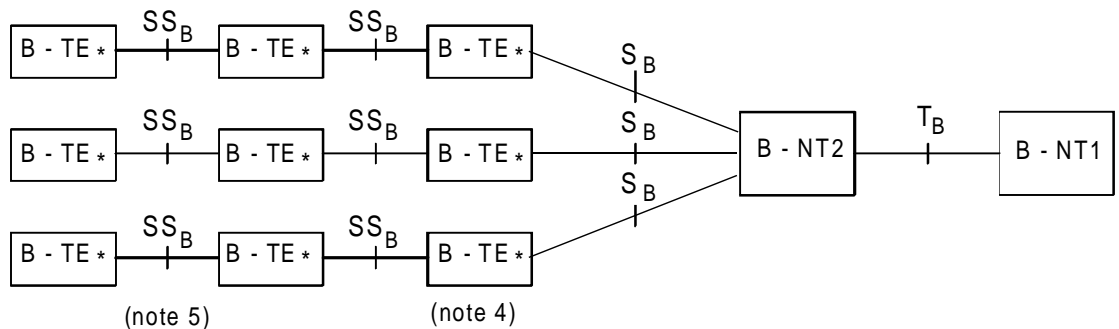

- NOTE 1: Medium Adaptor (MA): accommodates the specific topology of the distributed B-NT2. The interface at W may include topology dependant elements and may be a non-standardized interface.
- NOTE 2: There will be a physical link between these two MAs in the case of ring configurations.
- NOTE 3: There will be a physical link between B-TE* and B-NT2 in the case of ring configurations.
- NOTE 4: The B-TE* includes shared medium access functions.
- NOTE 5: The measurable physical characteristics of the SS_B interface are identical to those of the S_B interface. The functional characteristics of the interface, however, may be a superset of those at the S_B interface.
- NOTE 6: The B-NT2 may be null in the case of commonality between S_B and T_B .
- NOTE 7: Additional termination functions (e.g. for loopback in bus configuration) and OAM functions may be necessary for multi-access B-TE configurations. Requirements and implementations of these functions are for further study.

Figure 3 (concluded): Examples of physical configurations for multipoint applications

4.3 Basic characteristics of the interfaces at T_B and S_B reference points

4.3.1 Characteristics of the interfaces at 155 520 kbit/s

4.3.1.1 Interface at the T_B reference point

There is only one interface per B-NT1 at the T_B reference point. The operation of the physical medium is point-to-point in the sense that there is only one sink (receiver) in front of one source (transmitter).

Point-to-multipoint configurations at T_B at ATM and higher layers are for further study.

4.3.1.2 Interface at the S_B reference point

One or more S_B interfaces per B-NT2 are present. The interface at the S_B reference point is point-to-point at the physical layer in the sense that there is only one sink (receiver) in front of one source (transmitter) and may be point to multipoint at the other layers.

4.3.1.3 Relationship between interfaces at S_B and T_B

Configurations described in figures 2i) and 2j) require that the interface specifications at T_B and S_B should have a high degree of commonality, in order to ensure that a simple broadband terminal may be connected directly to the T_B interface.

The feasibility of achieving the needed commonality is for further study.

4.3.2 Characteristics of the interfaces at 622 080 kbit/s

4.3.2.1 Interface at T_B reference point

There is only one interface per B-NT1 at the T_B reference point. The operation of the physical medium is point-to-point in the sense that there is only one sink (receiver) in front of one source (transmitter).

Point-to-multipoint configurations at T_B at ATM and higher layers are for further study.

4.4 Relationship between ISDN interfaces

Figures 2g) and 2h) show configurations where B-ISDN and ISDN interfaces may occur at S_B and S respectively. In this case, B-NT2 functionalities have to ensure the interface capabilities for both S and S_B . Other configurations for supporting terminals at the interface at the S reference point may exist.

4.5 Functional groups characteristics

Lists of functions for each functional group are given below. Each particular function is not necessarily restricted to a single functional group. For example, "interface termination" functions are included in the function lists of B-NT1, B-NT2 and B-TE. The function lists for B-NT1, B-NT2, B-TE and B-TA are not exhaustive. Not all specific functions in a functional group need to be present in all implementations.

4.5.1 Network termination 1 for B-ISDN

This functional group includes functions broadly equivalent to layer 1 of the Open System Interconnection (OSI) reference model. Examples of B-NT1 functions are:

- line transmission termination;
- transmission interface handling;
- cell delineation;
- OAM functions.

4.5.2 Network termination 2 for B-ISDN

This functional group includes functions broadly equivalent to layer 1 and higher layers of the ITU-T Recommendation X.200 [10] reference model. B-NT2 can be null in the case of commonality between T_B and S_B .

Examples of B-NT2 functions are:

- adaptation functions for different media and topologies (MA functions);
- functions of a distributed B-NT2;
- cell delineation;
- concentration;
- buffering;
- multiplexing/demultiplexing;
- resource allocation;
- usage parameter control;
- adaptation layer functions for signalling (for internal traffic);
- interface handling (for the T_B and S_B interfaces);
- OAM functions;
- signalling protocol handling;
- switching of internal connections.

B-NT2 implementations may be concentrated or distributed. In a specific access arrangement, the B-NT2 may consist only of physical connections. When present, implementations of the B-NT2 are locally powered.

4.5.3 Terminal equipment for B-ISDN

This functional group includes functions broadly belonging to layer 1 and higher layers of the ITU-T Recommendation X.200 [10] reference model.

Examples of B-TE functions are:

- user/user and user/machine dialogue and protocol;
- interface termination and other layer 1 functions;
- protocol handling for signalling;
- connection handling to other equipments;
- OAM functions.

The possibility of powering the B-TE via the S_B interface is for further study.

4.5.3.1 Terminal equipment type 1 for B-ISDN

This functional group includes functions belonging to the B-TE functional group with an interface that complies with the B-ISDN S_B and/or T_B interface ETSSs.

4.5.3.2 Terminal equipment type 2 for B-ISDN

This functional group includes functions belonging to the functional group B-TE but with a broadband interface that complies with interface recommendations other than the B-ISDN interface recommendations or interfaces not included in ITU-T Recommendations.

4.5.4 Terminal adapter for B-ISDN

This functional group includes functions broadly belonging to layer 1 and higher layers of the ITU-T Recommendation X.200 [10] reference model that allow a TE2 or a B-TE2 terminal to be served by a B-ISDN user-network interface.

5 User network interface specifications

5.1 Interface location with respect to reference configuration

An interface point I_a is adjacent to the B-TE or the B-NT2 on their network side; interface point I_b is adjacent to the B-NT2 and to the B-NT1 on their user side (see figure 4).

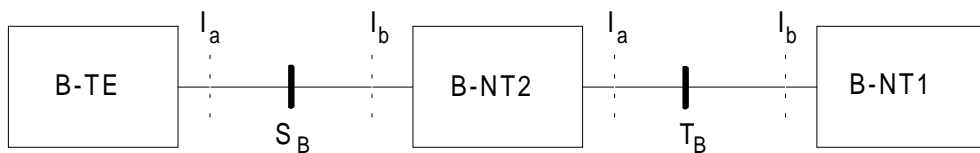
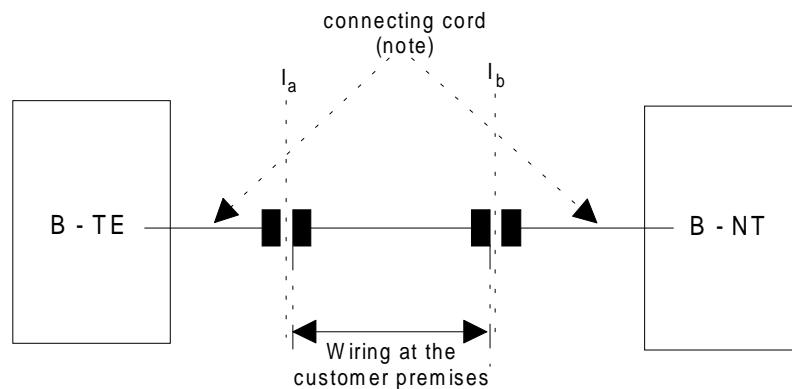

Figure 4: Reference configuration at reference points S_B and T_B

5.2 Interface location with respect to the wiring configuration

The interface points are located between the socket and the plug of the connector attached to the B-TE, B-NT2 or B-NT1. The location of the interface point is shown in figure 5.

In this ETS, the term "B-NT" is used to indicate network terminating layer 1 aspects of B-NT1 and B-NT2 functional groups, and the term "TE" is used to indicate terminal terminating layer 1 aspects of B-TE1, B-TA and B-NT2 functional groups, unless otherwise indicated.



NOTE: The length of the connecting cord can be zero.

Figure 5: Wiring configuration

6 Service and layering aspects of the physical layer

6.1 Services provided to the ATM-layer

The physical layer provides for the transparent transmission of ATM-PDUs between physical layer service access points (Ph-SAP). The ATM-PDU is called ATM cell. The ATM cell is defined in ITU-T Recommendation I.361 [6]. As no addressing is implemented in the physical layer only a single Ph-SAP can exist at the boundary between physical layer and ATM layer. The interarrival time between cells passed to the ATM layer is not defined (asynchronous transmission). The physical layer provides the ATM layer with timing information.

6.2 Service primitives exchanged with the ATM layer

The service primitives between physical layer and ATM layer are defined in ITU-T Recommendation I.361 [6], § 3.2.

6.3 Sublayering of the physical layer

The physical layer is subdivided into two sublayers:

- the Physical Medium (PM) sublayer;
- the Transmission Convergence (TC) sublayer.

No service access point and service primitives are defined between the PM and the TC sublayers. The functions of the individual sublayer are defined in ITU-T Recommendation I.321 [5].

7 Physical medium characteristics of the user network interface at 155 520 kbit/s

7.1 Characteristics of the interface at the T_B and S_B reference points

7.1.1 Bit rate and interface symmetry

The bit rate of the interface is 155 520 kbit/s. The interface is symmetric, i.e. it has the same bit rate in both transmission directions.

The nominal bit rate in free running clock mode shall be 155 520 kbit/s with a tolerance of ± 20 p.p.m.

7.1.2 Physical characteristics

Both optical and electrical interfaces are recommended. The implementation selected depends on the distance to be covered and user requirements arising from the details of the installation.

7.1.2.1 Electrical interface

7.1.2.1.1 Interface range

The maximum range of the interface depends on the specific attenuation of the transmission medium used. For example a maximum range of about 100 meters for microcoax (4 mm diameter) and 200 meters for Category 5 (CATV) type (7 mm diameter) can be achieved.

7.1.2.1.2 Transmission medium

Two coaxial cables, one for each direction, shall be used. The wiring configuration shall be point-to-point.

The impedance shall be 75Ω with a tolerance of $\pm 5 \%$ in the frequency range 50 MHz to 200 MHz.

The attenuation of the electrical path between the interface points I_a and I_b shall be assumed to follow an approximate \sqrt{f} law and to have a maximum insertion loss of 20 dB at a frequency of 155 520 kHz.

7.1.2.1.3 Electrical parameters at interface points I_a and I_b

The digital signal presented at the output port and the port impedance shall conform to ETS 300 166 [2] for the interface at 155,52 Mbit/s.

The digital signal presented at the input port and the port impedance shall conform to ETS 300 166 [2] for the interface at 155,52 Mbit/s, modified by the characteristics of the interconnecting coaxial pair.

7.1.2.1.4 Electrical connectors

The presentation of interface point I_b at B-NT1 or B-NT2 shall be via a socket.

The presentation of interface point I_a at B-TE or B-NT2 shall be using either:

- a) a socket, i.e. the connection shall be made to the equipment toward the network with a cable with plugs on both ends; or
- b) an integral connecting cord with plug on the free end.

7.1.2.1.5 Line coding

The line coding shall be Coded Mark Inversion (CMI), see ETS 300 166 [2].

7.1.2.1.6 EMC/EMI requirements

Shielding properties of connectors and cables are defined by the specification of the respective values for the Surface Transfer Impedance (STI). The template indicating the maximum STI values for category V cables is given in figure 6. For connectors, these template values shall be multiplied by 10 (20 dB).

The immunity of the interface against induced noise on the transmission medium should be specified by means of a Terminal Failure Voltage (TFV) which is overlaid to the digital signal at the output port. Figure 7 shows a possible measurement configuration.

The receiver should tolerate a sinusoidal TFV with the values defined in figure 8 and table 1 without degradation of the Bit Error Rate (BER) performance.

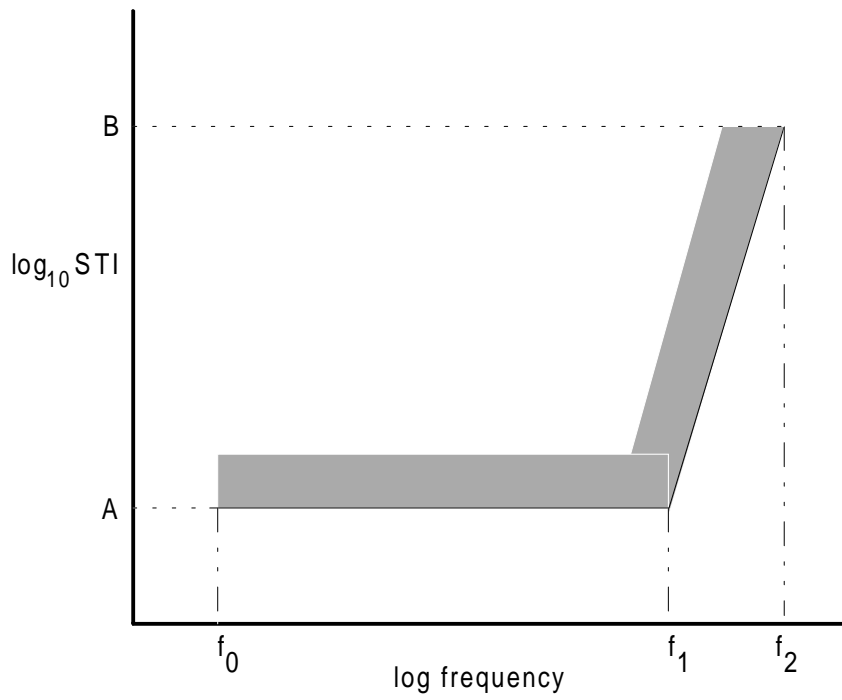

frequency (MHz):	STI value (W/m):
$f_0 = 0,1$	A = 0,01
$f_1 = 100$	
$f_2 = 1\ 000$	

The applicability of these values for microcoax cables is for further study.

Figure 6: Maximum STI values as a function of frequency

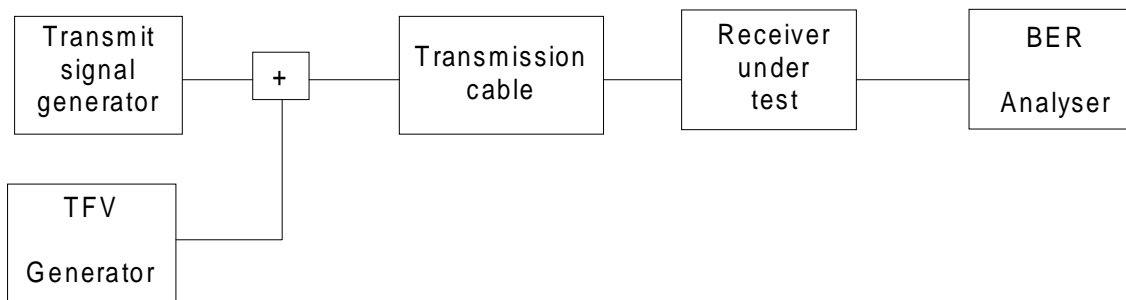

Figure 7: Measurement configuration

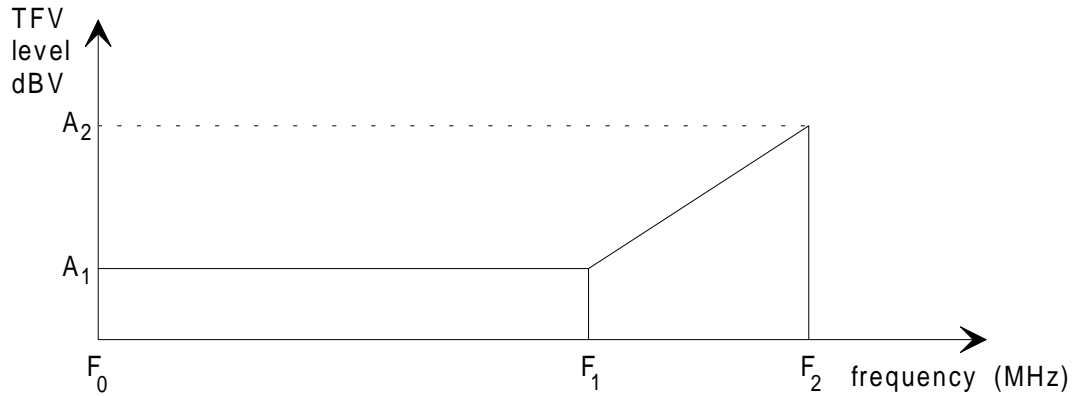

Figure 8: Terminal failure voltage frequency response

Table 1: Terminal failure voltage values

frequency (MHz)	TFV amplitude (dBV) (0 dBV = 1 V _{op})
F ₀ = 1	
F ₁ = 200	A1 ≥ -17
F ₂ = 400	A2 ≥ -11

7.1.2.2 Optical interface

7.1.2.2.1 Attenuation range

The attenuation of the optical path between the specification points S and R, as defined in ETS 300 232 [3], shall be in the range of 0 dB to 7 dB (see subclause 7.1.2.2.3.3).

7.1.2.2.2 Transmission medium

The transmission medium shall consist of two single mode fibres according to ITU-T Recommendation G.652 [1], one for each direction.

7.1.2.2.3 Optical parameters

7.1.2.2.3.1 Line coding

The line coding shall be binary Non Return to Zero (NRZ).

The convention used for optical logic level is:

- emission of light for a binary ONE;
- no emission of light for a binary ZERO.

The extinction ratio shall be in accordance with ETS 300 232 [3], application code I-1.

7.1.2.2.3.2 Operating wavelength

The operating wavelength shall be around 1 310 nm (second window).

7.1.2.2.3.3 Input and output port characteristics

The optical parameters shall be in accordance with ETS 300 232 [3], application code I-1. Some national application may use optical parameters for multi-mode fibres.

The specification points associated with interface points I_a and I_b correspond to measurement "reference points" S and R as defined in ETS 300 232 [3]. The optical parameters are specified for the transmitter and receiver at these specification points and for the optical path between these specification points, i.e. the connector at the interface is considered to be part of the equipment and not part of the fibre installation.

7.1.2.2.4 Optical connectors

The presentation of interface point I_b at B-NT1 or B-NT2 shall be via a socket.

The presentation of interface point I_a at B-TE or B-NT2 shall be using either:

- a) a socket, i.e. the connection shall be made to the equipment toward the network with a cable with plugs on both ends; or
- b) an integral connecting cord with plug on the free end.

7.1.2.2.5 Safety requirements

For safety reasons, the parameters for IEC Publication 825-1 [12], Class 1 devices shall not be exceeded, even under failure conditions.

7.1.2.3 Jitter and wander

For both electrical and optical B-UNI, the interface output jitter shall be in accordance with the appropriate limit given in ITU-T Recommendation G.825 [14] for the electrical and optical interface.

Equipments having an electrical or optical B-UNI (e.g. B-NT1, B-NT2, B-TE) and which meet the output jitter tolerance and the jitter transfer specifications given in ITU-T Recommendations G.825 [14] and G.958 [15] respectively, are assured of proper operation when the interface output jitter conforms to the limits in ITU-T Recommendation G.825 [14].

8 Physical medium characteristics of the UNI at 622 080 kbit/s

8.1 Characteristics of the interface at the T_B and S_B reference points

8.1.1 Bit rate and interface symmetry

The bit rate of the interface in at least one direction shall be 622 080 kbit/s. The following possible interfaces have been identified:

- a) an asymmetrical interface with 622 080 kbit/s in one direction and 155 520 kbit/s in the other direction;
- b) a symmetrical interface with 622 080 kbit/s in both directions.

If option a) is chosen, then the 155 520 kbit/s component should comply with the characteristics as given in clause 7.

The nominal bit rate in free running clock mode shall be 622 080 kbit/s with a tolerance of ± 20 p.p.m.

8.1.2 Physical characteristics

For the purposes of this ETS, only the optical interface is considered.

8.1.2.1 Attenuation range

The attenuation of the optical path between the specification points S and R shall be in the range of 0 dB to 7 dB (see subclause 7.1.2.2.3.3).

8.1.2.2 Transmission medium

The transmission medium shall consist of two single mode fibres according to ITU-T Recommendation G.652 [1], one for each direction.

8.1.2.3 Optical parameters

8.1.2.3.1 Line coding

The line coding shall be binary Non Return to Zero (NRZ).

The convention used for optical logic level is:

- emission of light for a binary ONE;
- no emission of light for a binary ZERO.

The extinction ratio shall be in accordance with ETS 300 232 [3], application code I-4.

8.1.2.3.2 Operating wavelength

The operating wavelength shall be around 1 310 nm (second window).

8.1.2.3.3 Input and output port characteristics

The optical parameters shall be in accordance with ETS 300 232 [3], application code I-4.

The specification points associated with interface points I_a and I_b correspond to measurement "reference points" S and R as defined in ETS 300 232 [3]. The optical parameters are specified for the transmitter and receiver at these specification points and for the optical path between these specification points, i.e. the connector at the interface is considered to be part of the equipment and not part of the fibre installation.

8.1.2.4 Optical connectors

The presentation of interface point I_b at B-NT1 or B-NT2 shall be via a socket.

The presentation of interface point I_a at B-TE or B-NT2 shall be using either:

- a) a socket, i.e. the connection shall be made to the equipment toward the network with a cable with plugs on both ends; or
- b) an integral connecting cord with plug on the free end.

8.1.2.5 Safety requirements

For safety reasons, the parameters for IEC Publication 825-1 [12], Class 1 devices shall not be exceeded even under failure conditions.

8.1.2.6 Jitter and wander

For both electrical and optical B-UNI, the interface output jitter shall be in accordance with the appropriate limit given in ITU-T Recommendation G.825 [14] for the electrical and optical interface.

Equipments having an electrical or optical B-UNI (e.g. B-NT1, B-NT2, B-TE) and which meet the output jitter tolerance and the jitter transfer specifications given in ITU-T Recommendations G.825 [14] and G.958 [15] respectively, are assured of proper operation when the interface output jitter conforms to the limits in ITU-T Recommendation G.825 [14].

9 Power feeding

9.1 Provision of power

The provision of power to the B-NT1 via the UNI network interface is optional. If the power is provided via the UNI, the following conditions shall apply:

- a separate pair of wires shall be used for the provision of power to the B-NT1 via the T_B reference point;
- the power sink shall be fed by either:
 - a source under the responsibility of the user when requested by the network provider;
 - a power supply unit under the responsibility of the network provider connected to the mains electric supply in the customer premises;
- the capability of the provision of power by the user side shall be available either:
 - as an integral part of the B-NT2/B-TE; and/or
 - physically separated from the B-NT2/B-TE as an individual power supply unit;
- a power source capable to feed more than one B-NT1 shall meet the requirements at each individual B-NT1 power feeding interface at the same point in time;
- a short-circuit or overload condition in any B-NT1 shall not affect the power feeding interface of the other B-NT1's.

9.2 Power available at B-NT1

The power available at the B-NT1 via the UNI shall be at least 15 W.

9.3 Feeding voltage

The feeding voltage at the B-NT1 shall be in the range of -20 V to -57 V relative to ground.

9.4 Safety requirements

In order to harmonize power source and sink requirements the following is required:

- a) the power source shall be protected against short-circuits and overload;
- b) the power sink of B-NT1 shall not be damaged by an interchange of wires.

With respect to the feeding interface of the power source, which is regarded as a touchable part in the sense of IEC Publication 950 [13], the protection methods against electric shock specified in IEC Publication 950 [13] may be applied.

10 Functions provided by the transmission convergence sublayer

10.1 Transfer capability

10.1.1 Interface at 155 520 kbit/s

The interface bit rate at the T_B and S_B reference points shall be 155 520 kbit/s. The bit rate available for the ATM cells (user information cells, signalling cells, OAM cells, unassigned cells and cells used for cell rate decoupling) excluding physical layer overhead cells (physical OAM cells and idle cells) shall be 149 760 kbit/s.

10.1.2 Interface at 622 080 kbit/s

The interface bit rate at the T_B and S_B reference points shall be 622 080 kbit/s. The bit rate available for the ATM cells (user information cells, signalling cells, OAM cells, unassigned cells and cells used for cell rate decoupling) excluding physical layer overhead cells (physical OAM cells and idle cells) shall be 599 040 kbit/s.

10.2 Physical layer aspects

The ATM cell shall be defined as in ITU-T Recommendation I.361 [6].

10.2.1 Timing

At the customer side of the interface at the T_B and S_B reference points the physical layer may derive its timing from the signal received across the interface or provide it locally by the clock of the customer equipment.

10.2.2 Interface structure for 155 520 kbit/s and 622 080 kbit/s

The interface structure consists of a continuous stream of cells. Each cell contains 53 octets. The maximum spacing between successive physical layer cells is 26 ATM layer cells, i.e. after 26 contiguous ATM layer cells have been transmitted, a physical layer cell is inserted in order to adapt the transfer capability to the interface rate. Physical layer cells are also inserted when no ATM layer cells are available.

The physical layer cells which are inserted can be either "idle cells" (see subclause 10.4) or physical layer OAM cells (see subclause 11.2), depending on the OAM requirements.

10.3 Header Error Control

10.3.1 Header Error Control functions

The Header Error Control (HEC) covers the entire cell header. The code used for this function is capable of either:

- single bit error correction; or
- multiple bit error detection.

The detailed description of the HEC procedure is given in subclause 10.3.2. Briefly, the transmitting side computes the HEC field value. The receiver has two modes of operation as shown in figure 9. The default mode provides for single-bit error correction. Each cell header is examined and, if an error is detected, one of two actions takes place. The action taken depends on the state of the receiver. In "correction mode" only single bit errors can be corrected and the receiver then switches to "detection mode". In "detection mode", all cells with detected header errors are discarded. When a header is examined and found not to be in error, the receiver switches to "correction mode". The term "no action" in figure 9 means no correction is performed and no cell is discarded.

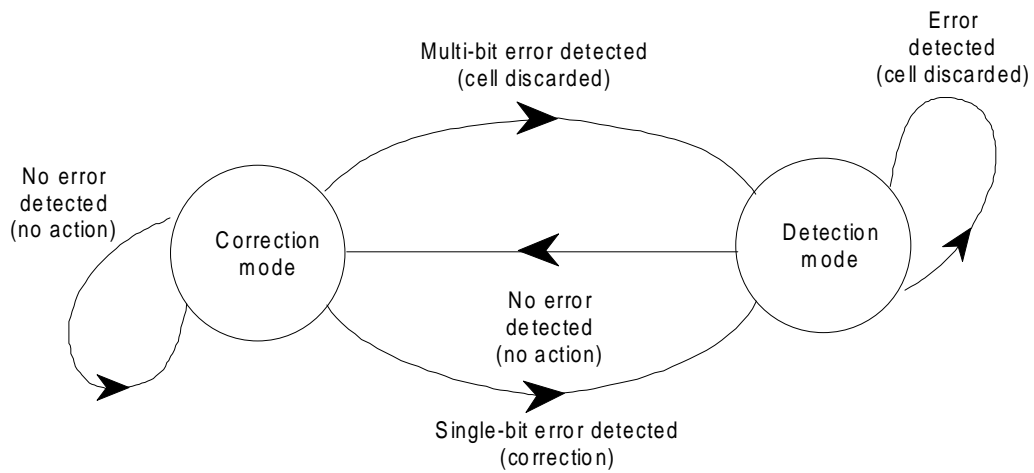
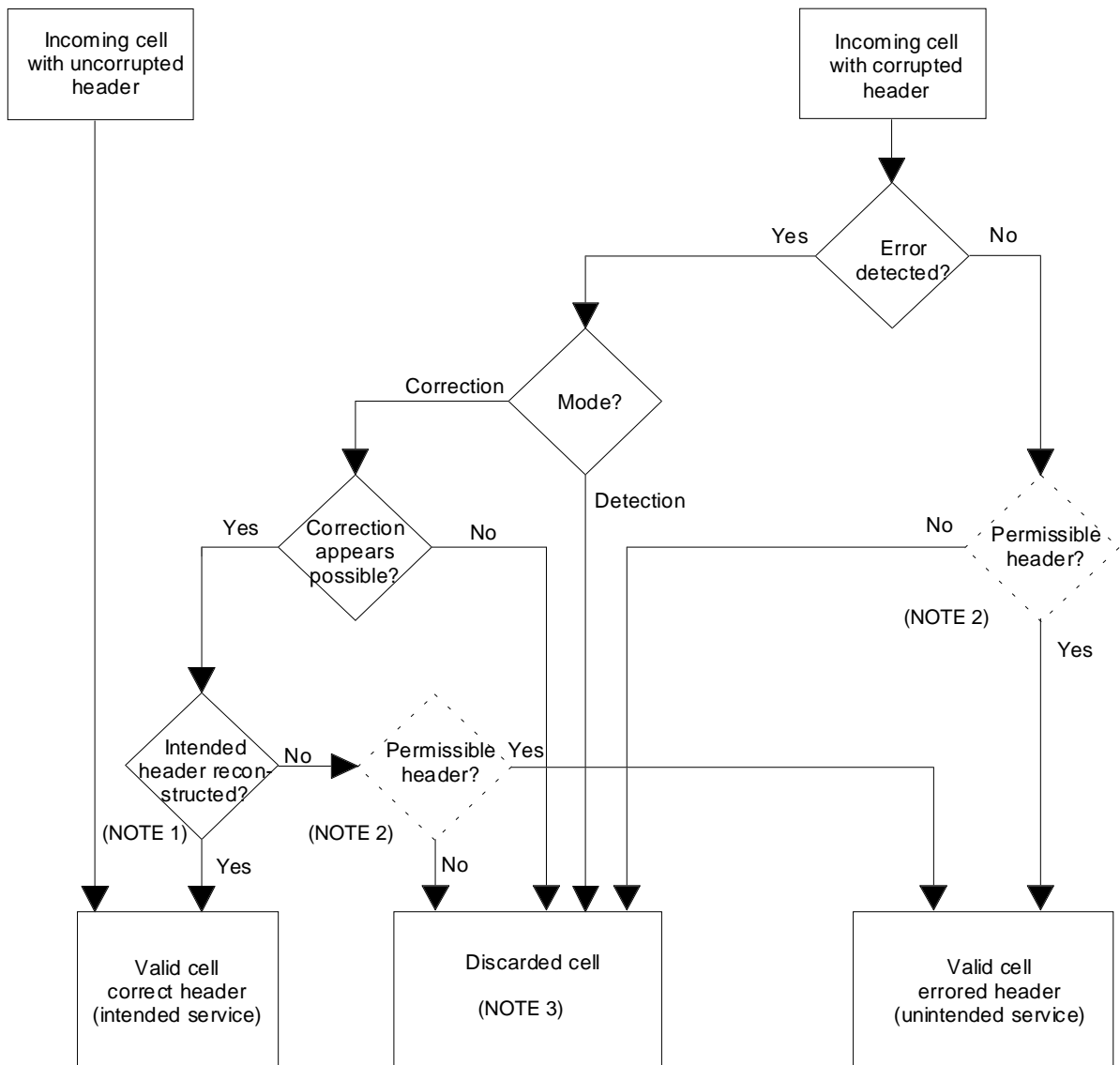



Figure 9: HEC - receiver modes of operation

The flow chart given in figure 10 shows the consequence of errors in the ATM cell header. The error protection function provided by the HEC provides both recovery from single bit header errors, and a low probability of the delivery of cells with errored headers under bursty error conditions. The error characteristics of fibre based transmission systems appear to be a mix of single-bit errors and relatively large burst errors. For some transmission systems, the error correction capability may not be invoked.



 Functions usually performed by the ATM layer

- NOTE 1: Intended service means the service requested by the originator, while unintended service means a possible service, but not that required by the originator. Definition of "valid cell": a cell where the header is declared by the header error control process to be free errors (ITU-T Recommendation I.113).
- NOTE 2: An example of an impermissible header is a header whose VPI/VCI is neither allocated to a connection nor pre-assigned to a particular function (idle cell, OAM cell, etc...). In many instances, the ATM layer will decide if the cell header is permissible.
- NOTE 3: A cell is discarded if its header is declared to be invalid, or if the header is declared to be valid and the resulting header is impermissible.

Figure 10: Consequences of errors in ATM cell header

10.3.2 Header Error Control (HEC) sequence generation

The transmitter calculates the HEC value across the entire ATM cell header and inserts the result in the appropriate header field. The notation used to describe the HEC is based on the property of cyclic codes. (For example code vectors such as "1000000100001" can be represented by a polynomial $P(x) = x^{12} + x^5 + 1$). The elements of a n-element code word are, therefore, the coefficients of a polynomial of order n-1. In this application, these coefficients can have the value 0 or 1 and the polynomial operations are performed using modulo 2 operations. The polynomial representing the content of a header excluding the HEC field is generated using the first bit of a header as the coefficient of the highest order term.

The HEC field shall be an 8-bit sequence. It shall be the remainder of the division (modulo 2) by the generator polynomial $G(x) = x^8 + x^2 + x + 1$ of the product x^8 , multiplied by the content of the header excluding the HEC field.

At the transmitter, the initial content of the register of the device computing the remainder of the division is pre-set to all 0s and is then modified by division of the header excluding the HEC field by the generator polynomial (as described above); the resulting remainder is transmitted as the 8-bit HEC.

To significantly improve the cell delineation performance in the case of bit-slips the following is recommended:

- the check bits calculated by the use of the check polynomial are added (modulo 2) to an 8-bit pattern before being inserted in the last octet of the header;
- the recommended pattern is "01010101" (the left bit is the most significant bit);
- the receiver shall subtract (which is equal to add modulo 2) the same pattern from the 8 HEC bits before calculating the syndrome of the header.

This operation in no way affects the error detection/correction capabilities of the HEC. As an example if the first 4 octets of the header were all zeros the generated header before scrambling would be "00000000 00000000 00000000 01010101". The starting value for the polynomial check is all zeroes.

10.4 Idle cells

Idle cells cause no action at a receiving node except for cell delineation including HEC verification. They are inserted and discarded for cell rate decoupling.

Idle cells are identified by the standardized pattern for the cell header shown in table 2.

Table 2: Header pattern for idle cell identification

	Octet 1	Octet 2	Octet 3	Octet 4	Octet 5
Header pattern	00000000	00000000	00000000	00000001	HEC = Valid code = 01010010

There is no significance to any of these individual fields from the point of view of the ATM layer, as physical layer OAM cells are not passed to the ATM layer.

The content of the information field is "01101010" repeated 48 times.

10.5 Cell delineation and scrambling

10.5.1 Cell delineation and scrambling objectives

Cell delineation is the process which allows identification of the cell boundaries. The ATM cell header contains a HEC field which is used to achieve cell delineation. The ATM signal is required to be self-supporting in the sense that it has to be transparently transported on every network interface without any constraints from the transmission systems used. Scrambling shall be used to improve the security and robustness of the HEC cell delineation mechanism as described in subclause 10.5.3. In addition it helps randomising the data in the information field for possible improvement of the transmission performance.

10.5.1.1 Cell delineation algorithm

Cell delineation shall be performed by using the correlation between the header bits to be protected (32 bits) and the relevant control bits (8 bits) introduced in the header by the HEC using a shortened cyclic code with generating polynomial $G(x) = x^8 + x^2 + x + 1$.

Figure 11 shows the state diagram of the HEC cell delineation method.

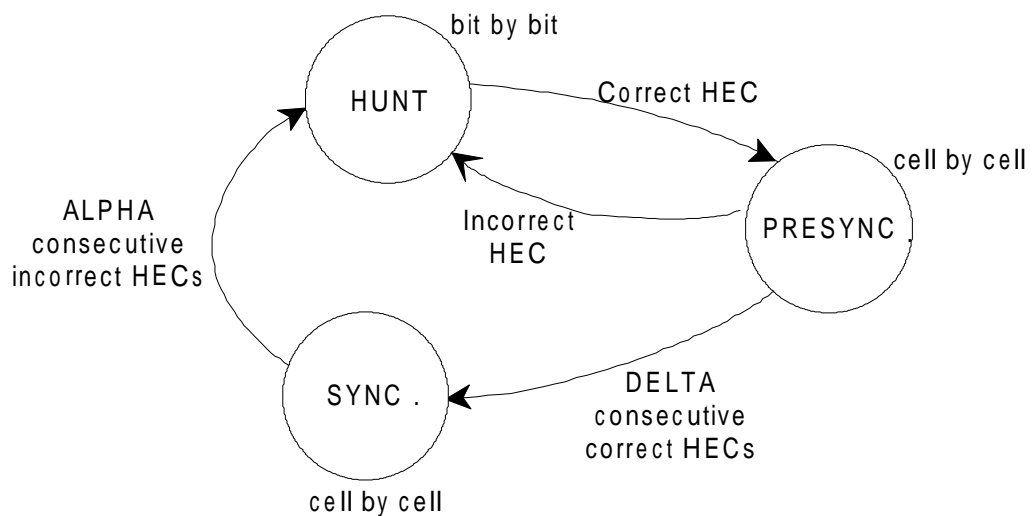

NOTE: The "correct HEC" means the header has no bit errors (syndrome is zero) and has not been corrected.

Figure 11: Cell delineation state diagram

The details of the state diagram are described below:

- 1) in the HUNT state, the delineation process is performed by checking bit by bit for the correct HEC (i.e. syndrome equals zero) for the assumed header field. For the cell based physical layer, prior to scrambler synchronization, only the last six bits of the HEC are to be used for cell delineation checking. Once such an agreement is found, it is assumed that one header has been found, and the process enters the PRESYNC state. When octet boundaries are available within the receiving physical layer prior to cell delineation, the cell delineation process may be performed octet by octet;
- 2) in the PRESYNC state, the delineation process is performed by checking cell by cell for the correct HEC. The process repeats until the correct HEC has been confirmed DELTA times consecutively at which point the process moves to the SYNC state. If an incorrect HEC is found, the process returns to the HUNT state. The total number of consecutive correct HEC required to move from the HUNT state to the SYNC state is therefore DELTA + 1;
- 3) in the SYNC state the cell delineation will be assumed to be lost if an incorrect HEC is obtained ALPHA times consecutively;

- 4) cells with correct HECs (or cell headers with single bit errors which are corrected) that are processed while the SYNC state shall be passed to the ATM layer. Cells with correct HECs that are checked while in the PRESYNC state may optionally be passed to the ATM layer, but only when they are part of the DELTA consecutive correct HECs necessary for transition to the SYNC state. The cell associated with the first correct HEC (in the HUNT state) may also optionally be passed to the ATM layer in conjunction with the DELTA cells just mentioned. In any case, idle cells and Physical Layer OAM cells are not passed to the ATM layer.

The parameters ALPHA and DELTA shall be chosen to make the cell delineation process as robust and secure as possible, while satisfying the performance specified in subclause 10.5.2. Robustness against false misalignments due to bit errors depends on ALPHA. Robustness against false delineation in the resynchronization process depends on the value of DELTA.

The values of ALPHA and DELTA shall be ALPHA = 7 and DELTA = 8.

10.5.2 Cell delineation performance

Figures A.1 and A.2 of annex A give provisional information on the performance of the cell delineation algorithm described in subclause 10.5.1.1 in the presence of random bit errors, for various values of ALPHA and DELTA.

10.5.3 Scrambler operation

The distributed sample scrambler is used for the cell based UNI.

10.5.3.1 Distributed sample scrambler (31st order)

The distributed sample scrambler is an example of a class of scrambler in which randomization of the transmitted data stream is achieved by modulo addition of a pseudo random sequence. Descrambling at the receiver is achieved by modulo addition of an identical locally generated pseudo-random sequence having phase synchronization with the first in respect of the transmitted cells. The scrambler does not affect the performance of the 8 bit HEC mechanism during steady state operation.

Phase synchronization of a receiver Pseudo Random Binary Sequence (PRBS) with polynomial generator order r is achieved by sending r linearly independent source PRBS samples through the transmission channel as conveyed data samples. When received without error these r samples are sufficient to synchronize the phase of the PRBS generator at the receiver to that of the transmitter PRBS generator.

A simple timing skew between the source PRBS samples and the conveyed PRBS samples serves as a means of decoupling the sample times of the source PRBS samples from the conveyed PRBS samples. This enables linear independence of PRBS samples to be simply achieved by taking samples at equal intervals of half an ATM cell from the source PRBS generator.

10.5.3.2 Transmitter operation

The transmitter pseudo random binary sequence is added (modulo-2) to the complete cell bit by bit excepting the HEC field. The pseudo random sequence polynomial is:

$$x^{31} + x^{28} + 1.$$

The Cyclic Redundancy Check (CRC) octet for each cell is then modified by modulo-2 addition of the CRC calculated on the 32 bit of the scrambler sequence coincident with the first 32 header bits. This is equivalent to calculation of the CRC on the first 32 bits of the scrambled header. The first two bits of the HEC field are then modified, as follows, by two bits from the PRBS generator. The two bits from the PRBS generator will be referred to as the PRBS source bits and the two bits of the CRC onto which they are mapped will be referred to as the PRBS transport bits.

To the first HEC bit (HEC_8) is added (modulo-2) the value of PRBS generator that was added (modulo-2) 211 bits earlier to the previous cell payload. To the second bit of the HEC field is added (modulo-2) the current value of the PRBS generator. These samples are exactly half a cell apart and the first (U_{t-211}) is delayed by 211 bits before conveyance (requiring one D-type latch for storage) (211 bits is 1 bit less than half a cell).

PRBS phase (as added to payload and all header except HEC).

U_{t-1}	U_t	U_{t+1}	U_{t+2}	U_{t+3}	U_{t+4}	U_{t+5}	U_{t+6}	U_{t+7}	U_{t+8}	U_{t+9}
-----------	-------	-----------	-----------	-----------	-----------	-----------	-----------	-----------	-----------	-----------

Resultant transmitted data element:

CLP	HEC ₈	HEC ₇							1st payload bit	2nd payload bit
+	+	+	HEC ₆	HEC ₅	HEC ₄	HEC ₃	HEC ₂	HEC ₁	+	+
U_{t-1}	U_{t-211}	U_{t+1}							U_{t+8}	U_{t+9}

10.5.3.3 Receiver operation

Three basic states of receiver operation are defined (see figure 12):

- 1) acquisition of scrambler synchronization (following cell delineation);
- 2) verification of scrambler synchronization;
- 3) steady state operation.

Receiver state 1): acquisition of scrambler synchronization (following cell delineation).

The principle of operation is as follows.

Cell delineation

The cell delineation mechanism is independent from the scrambler synchronization acquisition mechanism. Cell delineation is determined using the last six bits of the HEC field (only). The first two bits have been modified by the modulo addition of the conveyed data samples and cannot therefore be used for delineation or CRC evaluation until the scrambler is synchronized.

Acquisition of scrambler synchronization

The conveyed bits are extracted by modulo addition of the predicted values for HEC₈ and HEC₇ from the received values. Scrambler synchronization may for example be achieved by applying the conveyed samples at half cell intervals to a recursive descrambler (figure B.1). In order to ensure the samples are added into the recursive descrambler at the same interval they were extracted from the source PRBS, the second sample U_{t+1} (derived from HEC₇) is stored for 211 bits before it is used.

Additionally, because both samples are applied to the recursive descrambler 211 bits behind their point of modulo addition to the transmitted data sequence, the recursive descrambler feed-forward taps are chosen to generate a sequence that is advanced by 211 samples. Similarly, the verification comparison made in the recursive descrambler between the conveyed bits and their prediction is delay equalized using one bit stores as illustrated in figure B.1.

Time to achieve scrambler synchronization

2 bits of information are conveyed per cell which are linearly independent. The number of consecutive error free conveyed samples needed to synchronize the descrambler will be equal to the length of the scrambler, therefore, 16 cells provide the 31 samples necessary to synchronize the scrambler.

The scrambler synchronization process is not disabled during cell delineation, however, the descrambler will not begin to converge until the cell delineation mechanism has located the true position of the HEC sequence in the header and is no longer in its hunt state. Therefore, the start of scrambler synchronization acquisition convergence will be coincident with the final transition from the hunt state to the presync state of the cell delineation mechanism.

Receiver state 2): verification of scrambler synchronization

The verification state differs from the acquisition state in that the recursive descrambler is no longer modified with synchronising samples. Verification is needed because undetectable errors in the conveyed bits may have occurred during the acquisition phase. Verification tests the predicted PRBS in the receiver against the remote reference sequence given by the conveyed samples. To verify scrambler acquisition phase overall such that the probability of false synchronization is less than 10^{-6} , requires 16 verifications where the transmission error ratio is better than 10^{-3} .

Receiver State 3): steady state operation (synchronized scrambler)

In this state the HEC₈ and HEC₇ bits can both be returned to normal use following their descrambling. Properties of error detection and correction are not affected by this process. Both cell delineation and scrambler synchronization are reliably monitored in this state by the existing cell delineation state machine.

HEC regeneration and header scrambling

The HEC bits in the transmitted cell were modified prior to transmission to correspond to the HEC for the scrambled header. To reverse this process where required and regenerate an HEC that corresponds to the unscrambled header, the HEC bits may be modified by modulo-2 addition of the CRC calculated on the 32 bits of the descrambler sequence coincident with the first 32 header bits.

Automatic scrambling detection

If scrambling is not used, then the conveyed PRBS samples derived from the corresponding HEC₇ and HEC₈ bits will have the value zero. Therefore, these bits used to derive the phase of the descrambler, will seed the descrambler with zeroes inhibiting the PRBS of the descrambler automatically. Therefore, the absence of scrambling by the transmitter can be detected automatically by the receiver and correctly handled.

10.5.3.4 State transition diagram and mechanism

The three states of the scrambler are acquisition, verification and steady state.

The transition between these states may be determined by reference to the value of a single confidence counter (C) as follows:

initial state = acquisition, confidence counter initial value = 0.

State 1: acquisition: confidence counter range 0 to X-1

For every cell received correctly with no errors detected in HEC bits 1 to 6 the confidence counter is incremented by one and the two conveyed bits used to drive the recursive descrambler into synchronization.

Any error detected in the cell header results in a return to the initial state (the confidence counter being reset to zero).

Transition to the verification state occurs when the confidence counter reaches X (proposed value of X = 16).

State 2: verification: confidence counter range X to Y-1

For every cell received without detected errors, the two conveyed bits are compared to their predicted values. For each cell with two correct predictions received, the confidence counter is incremented. If one or two incorrect predictions are made then the counter is decremented. If the counter falls below V (proposed value of V = 8) the system returns to the acquisition initial state 1 and the confidence counter is reset.

Transition to the steady state occurs when the counter reaches Y (proposed value of Y = 24).

State 3: steady state: confidence counter range Y to Z

The rules for incrementing and decrementing the confidence counter are as for state 2. The acquisition state is returned to automatically should the counter drop below $W (= 16)$. The confidence counter has an upper limit of Z (proposed value 24).

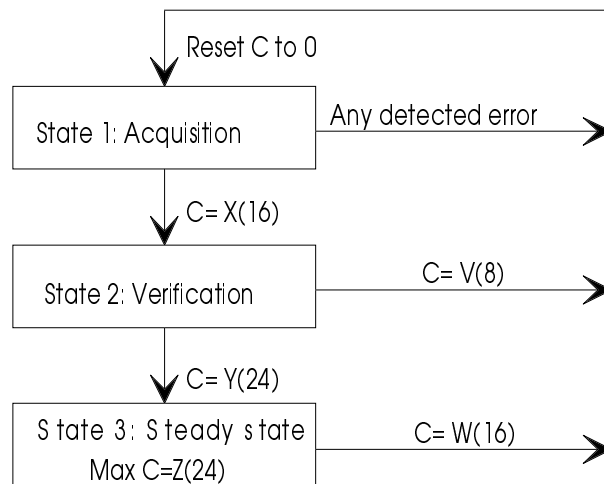

Figure 12: State transition diagram

11 UNI related OAM functions

The following OAM functions associated with the UNI have been identified and are described in ITU-T Recommendation I.610 [9] (with the amendments detailed in I-ETS 300 404 [11]):

- 1) transmission and reception of maintenance signals (e.g. Alarm Indication Signal (AIS) and Remote Defect Indication (RDI) signal);
- 2) performance monitoring;
- 3) control communications provisions.

Some overhead capacity needs to be allocated to these functions.

11.1 Transmission overhead allocation

Physical layer OAM cells are used for the conveyance of the physical layer OAM information. How often OAM cells are inserted should be determined by OAM requirements. However there can be no more than one physical layer OAM cell every 27 cells and not be less than one physical layer OAM cell every 513 cells per flow in operational status. It is recognized that during some phases, for example start up, it would be desirable to increase the insertion rate of the physical layer OAM cell for improving the system response. These spacings would apply only when the flow is actually implemented; it is recognized that not all applications will require implementations of all flows.

11.2 OAM cell identification

ITU-T Recommendation I.610 [9] identifies three types of physical layer OAM flows carried by maintenance cells using a specific pattern in the header:

- F1: regenerator level;
- F2: digital section level;
- F3: transmission path level.

The F1 cell carries the OAM functions for the regenerator level.

These physical layer OAM cells are inserted in the cell flow on a recurrent basis. If these physical layer OAM cells have to take priority over an ATM cell, this has to be done without restricting ATM layer transfer capability. The minimum periodicity of the cell is defined by the requirements on availability of the section as one F1 cell in 513 cells for the 622 080 kbit/s bit rate and as one F1 cell in 377 cells for the 155 520 kbit/s bit rate.

The OAM flow F2 is not used and the corresponding functions are supported by the F3 OAM flow because there is no frame multiplexing in the cell based physical layer and consequently, only two flows are needed, but the numbering is made with reference to the corresponding OAM flows for the SDH physical layer.

The F3 cell carries the OAM functions for the transmission path level. These physical layer OAM cells are inserted in the cell flow on a recurrent basis. If these physical layer OAM cells have to take priority over an ATM cell, this has to be done without restricting ATM layer transfer capability. The minimum periodicity of the cell is defined by the requirements on availability of the path as one F3 cell in 513 cells for the 622 080 kbit/s bit rate and as one F1 cell in 377 cells for the 155 520 kbit/s bit rate.

The physical layer OAM cells shall have a unique header so that they can be properly identified by the physical layer at the receiver. The patterns to be used are shown in table 3 (see note). The header patterns shown are given prior to scrambling.

Table 3: Header pattern for OAM cell identification

Flow	Octet 1	Octet 2	Octet 3	Octet 4	Octet 5
F1	00000000	00000000	00000000	00000011	HEC = valid code 01011100
F3	00000000	00000000	00000000	00001001	HEC = valid code 01101010
NOTE: There is no significance to any of these individual fields from the point of view of the ATM layer, as physical layer OAM cells are not passed to the ATM layer.					

11.3 Allocation of OAM functions in information field

The octet allocation for the F1 physical layer OAM and F3 physical layer OAM cells is shown in figure 13.

NOTE: Value in parentheses indicates the number of bits used.

	MSB	LSB
1	R	
2	AIS	
3	PSN	
4	0	0 0 0 0 0 0
5	NIC(10) (note 1)	
6	MSB	
7	NMB-EDC	
8	EDC B1	
9	EDC B2	
10	EDC B3	
11	EDC B4	
12	EDC B5	
13	EDC B6	
14	EDC B7	
15	EDC B8	
16	R	
17	R	
18	R	
19	R	
20	R	
21	R	
22	R	
23	R	
24	R	

	MSB	LSB
25	R	
26	R	
27	R	
28	R	
29	R	
30	0 0 0 0	RDI (note 2)
31	NMB-EB	
32	EB2	EB1
33	EB4	EB3
34	EB6	EB5
35	EB8	EB7
36	R	
37	R	
38	R	
39	R	
40	R	
41	R	
42	R	
43	R	
44	R	
45	R	
46	TEB (note 3)	
47	0 0 0 0 0 0	
48	CEC(10) (note 4)	

NOTE 1: MSB is bit 2 of byte 4 and LSB is bit 1 of byte 5.

NOTE 2: RDI is bit 1 of byte 30.

Bits 2 to 8 are encoded as follow:
 00000011 : RDI is triggered by AIS,
 00000101 : RDI is triggered by LOS,
 00000111 : RDI is triggered by LOM,
 00001001 : RDI is triggered by LCD,
 bits 5 to 8 are for future used.

NOTE 3: When not used, this byte is encoded 6A hexa.

NOTE 4: MSB is bit 2 of byte 47 and LSB is bit 1 of byte 48.

Figure 13: Allocation of OAM functions in information field

The following fields are identified for the F3 flow:

- **Physical layer OAM Sequence Number (PSN):** Is designed to have a sufficiently large cycle compared with the duration of cell loss and insertion. 8 bits are allocated to the PSN. The counting is then done modulo 256;
- **Number of Included Cells (NIC):** Gives the number of cells included between the previous and the present F3 physical layer OAM cell. It includes the number of ATM cells and idle cells but not the physical layer OAM cells. The maximum value will be 375 cells for the 155 520 kbit/s bit rate and 511 cells for the 622 080 kbit/s bit rate;
- **transmission path error monitoring and reporting:** Includes the fields defined below:
 - **Monitoring Block Size (MBS):** The MBS is selected by balancing efficiency and monitoring accuracy. MBS should be fixed within the range (15-47) cells for the 155 520 kbit/s interface and within the range (36-64) cells for the 622 080 kbit/s interface;

- **Number of Monitored Blocks (NMB-EDC):** Gives the number of blocks included between this cell and the previous F3 OAM cell. This means the number of blocks for which error detection codes are contained in the following octets **NMB-EDC = 8** is proposed as an upper limit. The entire octet shall be allocated;
- **Error Detection Code (EDC):** This code is a BIP-8 calculated on a block of MBS cells repeated for each monitored block. An octet shall be allocated for each block;
- **Number of Monitored Blocks at the far end (NMB-EB):** Gives the number of TP-FEBEs carried in the following octets, **NMB-EB = 8** is proposed as an upper limit. The entire octet shall be allocated;
- **Path Remote Error Indication (P-REI), (EB1, EB2, ..., EB8):** This reports the number of parity violations in each block. Four bits are necessary to indicate the number of parity violations in a Bit Interleaved Parity 8 (BIP8). With **NMB-EB = 8**, a total of 4 octets is necessary;
- **Path Far End Total Errored Blocks (TEB):** gives the total number of errored blocks between two consecutive F3 OAM cells in accordance with anomalies a1 to a4 defined in Annex 4 of ITU-T Recommendation G.826 [16]. When this field is not used, the coding is 6A hexa;
- **Path Alarm Indication Signal (P-AIS):** One octet is allocated (the coding to indicate the presence of P-AIS is binary "1111 1111");
- **Path Remote Defect Indication (P-RDI):** One bit shall be allocated. This bit shall be set when one of the defects LCD, LOM, LOS or AIS (see subclause 11.4) is detected;
- **Cell Error Control (CEC):** CEC is used to detect errors in the cell payload. A CRC 10 is used:
$$G(x) = x^{10} + x^9 + x^5 + x^4 + x + 1;$$
- **Reserved field (R):** Contains the octet pattern of "0110 1010", which is the same as that of the idle cells.

The following fields are identified for the F1 flow:

- **Physical layer-OAM Sequence Number (PSN):** Is designed to have a sufficiently large cycle compared with the duration of cell loss and insertion. 8 bits are allocated to the PSN. The counting is then done modulo 256;
- **Number of Included Cells (NIC):** Gives the number of cells included between the previous and the present F1 physical layer OAM cell. It includes the number of ATM cells and idle cells, but not the physical layer OAM F3 cells. The maximum value will be 375 cells for the 155 520 kbit/s bit rate and 511 cells for the 62 080 kbit/s bit rate;
- **section error monitoring and reporting:** Includes the fields defined below:
 - **Monitoring Block Size (MBS):** The MBS is selected by balancing efficiency and monitoring accuracy. MBS should be fixed within the range (15-47) cells for the 155 520 kbit/s interface and within the range (36-64) cells for the 622 080 kbit/s interface;
 - **Number of Monitored Blocks (NMB-EDC):** Gives the number of blocks included between this cell and the previous F1 OAM cell. This means the number of blocks for which error detection codes are contained in the following octets **NMB-EDC = 8** as an upper limit. The entire octet shall be allocated;
 - **Error Detection Code (EDC):** This code is a BIP-8 calculated on a block of MBS cells repeated for each monitored block. An octet shall be allocated for each block;

- **Number of Monitored Blocks at the far end (NMB-EB):** Gives the number of transmission S-FEBEs carried in the following octets, NMB-EB = 8 is proposed as an upper limit. The entire octet shall be allocated;
- **Section Remote Error Indication (S-REI):** (EB1, EB2, ..., EB8): This reports the number of parity violations in each block. Four bits are necessary to indicate the number of parity violations in a BIP8. With NMB-EB = 8, a total of 4 octets is necessary;
- **Section Far End Total Errored Blocks (TEB):** gives the total number of errored blocks between two consecutive F1 OAM cells in accordance with anomalies a1 to a4 defined in Annex 4 of ITU-T Recommendation G.826 [16]. When this field is not used, the coding is 6A hexa;
- **Section Alarm Indication Signal (S-AIS):** One octet is allocated (the coding to indicate the presence of S-AIS is binary "1111 1111");
- **Section Remote Defect Indication (S-RDI):** One bit shall be allocated. This bit shall be set when one of the defects: Loss Of Cell delineation (LCD), Loss Of OAM cell delineation (LOM), Loss Of Signal (LOS) or unacceptable error performance, is detected;
- **Cell Error Control (CEC):** Is used to detect errors in the cell payload. A CRC 10 is used:
$$G(x) = x^{10} + x^9 + x^5 + x^4 + x + 1;$$
- **Reserved field (R):** Contains the octet pattern of "0110 1010", which is the same as that of the idle cells.

11.4 Maintenance signals

The following maintenance signals are defined:

- **Path Alarm Indication Signal (P-AIS):** This is used to alert the associated termination point in the direction of transmission that a failure has been detected and alarmed;
- **Path Remote Defect Indication (P-RDI):** This is provided to alert the equipment in the opposite direction of transmission that a defect has been detected along the path. It is set when a LCD, LOM, LOS or AIS signal has been detected at the path level. The time to set this signal needs to be as short as possible, but long enough to filter intermittent defect information. This time is to be defined. LCD is provided by the cell delineation algorithm. The time to indicate this state is to be defined. Loss of one OAM cell is detected when no F3 OAM cell is received when the maximum space between two F3 OAM cells is exceeded. A loss of maintenance flow (LOM) is detected when two successive anomalies loss of one F3 OAM cell are detected. The method of detection of the AIS condition is for further study;
- **Section Alarm Indication Signal (S-AIS):** This is used to alert the equipment in the direction of transmission that a failure has been detected and alarmed;
- **Section Remote Defect Indication (S-RDI):** This is provided to alert the equipment in the opposite direction of transmission that a defect has been detected along the path. It is set when a LCD, LOM, LOS or unacceptable error performance has been detected at the regenerator section level. The time to set this signal needs to be as short as possible but long enough to filter intermittent defect information. This time is to be defined. LCD is provided by the cell delineation algorithm. The time to indicate this state is to be defined. Loss of one OAM cell is detected when no F1 OAM cell is received when the maximum space between two F1 OAM cells is exceeded. A loss of maintenance flow (LOM) is detected when two successive anomalies Loss of One F1 OAM cell are detected. The method of detection of unacceptable error performance requires further study.

11.5 Transmission performance monitoring

Transmission performance monitoring across the UNI is performed to detect and report transmission errors. At the transmission path (F3) level, this function is performed on the ATM layer cells and idle cells. At the regenerator section (F1) level this function is performed on ATM layer cells, idle cells and higher level PL-OAM cells. The PL-OAM cell carries the result for the monitoring of a certain number of blocks:

- **Error Performance reporting:** This function reports to the equipment in the opposite direction of transmission, the results of the path error monitoring carried out (REI). For a BIP, it gives the number of parity violations in each block, calculated at the receiving end by comparison with the result carried by the cell.

11.6 Control communication

The provision of a data communication channel is for further study.

12 Operational functions

12.1 Description of signals at the interface

12.1.1 Signals defined in Recommendation I.610

The following signals related to maintenance are defined below:

- indication of LOS and LCD are generated within the functional equipment;
- section-AIS, path-AIS, section-RDI, path-RDI are signals transmitted/received across the B-UNI.

Loss of signal (LOS): LOS is considered to have occurred when the amplitude of the relevant signal has dropped below prescribed limits for a prescribed period.

Loss of Maintenance flow (LOM): Loss of one OAM cell is detected when no F3 or F1 OAM cell is received when the maximum space between two F3 or F1 OAM cells is exceeded. The defect LOM is declared when two successive anomalies Loss of One F3 or F1 OAM cell are detected.

SECTION Alarm Indication Signal (S-AIS): SECTION AIS is the 8 bits of the octet 2 of the F1 physical layer OAM cell payload set to all ones. On detecting LOS, LCD or LOM on the incoming signal, SECTION AIS is generated within a time to be defined (typically some microseconds) by sending a F1 physical layer OAM cell with octet 2 set to binary "1111 1111".

PATH Alarm Indication Signal (P-AIS): PATH AIS is sent to alert equipment in the direction of transmission that a failure has been detected. PATH-AIS is the 8 bits of the octet 2 of the F3 physical layer OAM cell payload set to all ones. On detecting a failure or SECTION AIS, PATH AIS is generated within a time to be defined (typically some microseconds) by sending a F3 physical layer OAM cell with octet 2 set to binary "1111 1111".

SECTION Remote Defect Indication (S-RDI): SECTION RDI alerts equipment in the opposite direction of transmission that a failure has been detected. On detecting LOS, LCD, LOM, or a SECTION AIS on the incoming signal, SECTION RDI is sent within a time to be defined (typically some microseconds) by inserting the code "1" in bit 1 octet 30 of the F1 physical layer OAM cell payload.

PATH Remote Defect Indication (P-RDI): PATH RDI alerts the associated path terminating equipment that a failure in the direction of transmission has been declared along the Path. Declaration occurs if the LOS, LCD, LOM, SECTION AIS or PATH AIS persists for typically a time to be defined (typically some seconds) by inserting the code "1" in bit 1 octet 30 of the F3 physical layer OAM cell payload.

12.1.2 Cell Delineation signals

Out of Cell Delineation (OCD): an OCD anomaly occurs when the cell delineation process changes from SYNC to HUNT state while in working state (refer to figure 11). An OCD anomaly terminates when the PRESYNC to SYNC state transition occurs (refer to figure 11) or when the OCD anomaly persists and the LCD maintenance state is entered (see below).

Loss of Cell Delineation (LCD): an LCD defect occurs when an OCD anomaly (see above) has persisted for x milliseconds. An LCD defect terminates when the cell delineation process (refer to figure 11) enters and remains in the SYNC state for x continuous milliseconds. The value of x is for further study.

NOTE: For implementations where the value of x is zero, the conditions for existing OCD and LCD signal states are identical, and equivalent to the signal LOC (Loss Of Cell Delineation) used in this ETS.

12.2 Definitions of state tables at network and user sides

The user side and network side of the interface have to inform each other of the layer 1 states in relation to the different defects that could be detected.

For the purpose, two state tables are defined, one at the user side and one at the network side. States at the user side (F states) are defined in subclause 12.2.1 and states at the network side (G states) are defined in subclause 12.2.2. The state tables are defined in subclause 12.2.4.

Fault conditions FC1 to FC4 that could occur at the network side or between the network side and user side are defined in figure 14. These fault conditions directly affect the F and G states. Information on these fault conditions is exchanged between the user and network sides in the form of signals defined in subclause 12.1.

NOTE 1: Only stable states needed for OAM of the user and the network side of the interface (system reactions, user and network relevant information) are defined. The transient states relative to the detections of the error information are not taken into account, except for power on/off states F6 and G13.

NOTE 2: The user does not need to know where a failure is located in the network. The user should be informed on the availability and the continuity of the layer 1 service.

NOTE 3: The user has all information relative to the performance associated with each direction of its adjacent section. The supervision of the quality of this section is the user's responsibility.

12.2.1 Layer 1 states on the user side of the interface

FO state: loss of power on the user side:

- in general, the TE can neither transmit nor receive signals.

F1 state: operational state:

- network timing and layer 1 service is available;
- the user side transmits and receives operational cells.

F2 state: fault condition No. 1:

- this fault state corresponds to the fault condition FC1;
- network timing is available at the user side;
- the user side transmits operational cells;
- the user side receives physical layer OAM cells containing P-RDI indication and not S-RDI.

F3 state: fault condition No. 2:

- this fault state corresponds to any combination of FC2 with FC1, FC3 and FC4;
- network timing may no longer be available through the link;
- the user side detects LOS, LCD;
- the user side transmits physical layer OAM cells with associated S-RDI and P-RDI.

F4 state:

- this fault state corresponds to fault condition FC3, or FC1 and FC3, or FC3 and FC4;
- network timing may no longer be available through the link;
- the user side detects P-AIS, or LCD;
- the user side transmits physical layer OAM cells containing P-RDI indication.

F5 state: Fault condition No. 4:

- this fault state corresponds to the fault condition FC4 or FC1 and FC4;
- network timing is available at the user side;
- the user side transmits operational cells;
- the user side receives physical layer OAM cells containing S-RDI and P-RDI indications.

F6 state:

- this fault corresponds to fault conditions FC3 + FC4 or FC3 + FC4 + FC1;
- network timing may no longer be available through the link;
- the user side receives physical layer OAM cells containing S-RDI, P-RDI and P-AIS;
- the user side transmits physical layer OAM cells containing P-RDI.

F7 state: power on state:

- this is a transient state and the user side may change the state after detection of the signal received.

12.2.2 Layer 1 states at the network side of the interface

GO state: loss of power on the network side:

- in general, the B-NT1 can neither transmit nor receive any signal.

G1 state: operational state:

- the network timing and layer 1 service is available;
- the network side transmits and receives operational cells.

G2 state: fault condition No. 1:

- this fault state corresponds to the fault condition FC1;
- network timing is provided to the user side;
- the path terminating equipment within the access network detects LOS, LCD, or receives S-AIS;
- the network side transmits physical layer OAM cells containing P-RDI indication and not S-RDI.

G3 state: fault condition No. 2:

- this fault state corresponds to the fault condition FC2;
- network timing may no longer be available through the link;
- the network side transmits operational cells;
- the network side receives physical layer OAM cells containing S-RDI and P-RDI indications.

G4 state: fault condition No. 3:

- this fault state corresponds to the fault condition FC3;
- network timing is not provided to the user side;
- the B-NT1 detects LOS or S-AIS from the access network;
- the network side transmits P-AIS;
- the network side receives physical layer OAM cells containing P-RDI indication.

G5 state:

- this fault state corresponds to the fault condition FC4 or FC2 and FC4;
- The network side detects LOS, LCD or LOM;
- the network side transmits physical layer OAM cells containing S-RDI and P-RDI indication to the user side.

G6 state:

- this fault state corresponds to fault conditions FC1 and FC2;
- network timing may no longer be available through the link;
- the network side transmits physical layer OAM cells containing P-RDI indication;
- the B-NT1 receives S-RDI and P-RDI indications from the user side and the PATH terminating equipment detects LOS, LCD or receives S-AIS.

G7 state:

- this fault state corresponds to fault conditions FC1 and FC3;
- network timing may no longer be available through the link;
- the network side transmits physical layer OAM cells containing P-AIS indication;
- the network side receives physical layer OAM cells containing P-RDI.

G8 state:

- this fault state corresponds to fault conditions FC1 and FC4 or FC1 and FC2 and FC4;
- the network side transmits physical layer OAM cells containing S-RDI and P-RDI indications to the user side.

G9 state:

- this fault state corresponds to fault conditions FC2 and FC3;
- network timing may no longer be available through the link;
- the network side transmits physical layer OAM cells containing P-AIS;
- the network side receives physical layer OAM cells containing S-RDI and P-RDI indications.

G10 state:

- this fault state corresponds to fault conditions FC3 and FC4 or FC2 and FC3 and FC4;
- network timing is not provided to the user side;
- the network side transmits physical layer OAM cells containing P-AIS and S-RDI indication to the user side.

G11 state:

- this fault state corresponds to fault conditions FC1 and FC2 and FC3;
- network timing may no longer be available through the link;
- the network side transmits P-AIS to the user side;
- the network side receives physical layer OAM cells containing S-RDI and P-RDI indications.

G12 state:

- this fault state corresponds to fault conditions FC1 and FC3 and FC4 or FC1 and FC2 and FC3 and FC4;
- network timing may no longer be available through the link;
- the network side transmits physical layer OAM cells containing P-AIS, P-RDI and S-RDI to the user side.

G13 state: Power on state:

- this is a transient state and the network side may change the state after detection of the signal received.

12.2.3 Definition of primitives

The following primitives should be used between the physical media dependent layer and the management entity (Management Physical Header (MPH) primitives):

MPH-AI	MPH ACTIVATE INDICATION (is used as error recovery and initialization information);
MPH-DI	MPH DEACTIVATE INDICATION;
MPH-EIn	MPH ERROR INDICATION with parameter n (n defines the failure condition relevant to the reported error);
MPH-CIn	MPH CORRECTION INDICATION with parameter n (n defines the failure condition relevant to the reported recovery);
PH-AI	PH ACTIVE INDICATION;
PH-DI	PH DEACTIVE INDICATION.

12.2.4 State tables

Operational functions are defined in table 4 for the layer 1 states at the user side of the interface and in table 5 for the network side.

General information for the state table matrix consideration.

Explanations of the symbols used in the table:

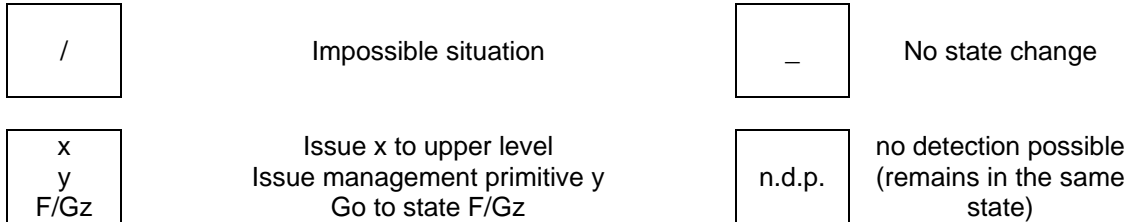

Location of fault conditions:

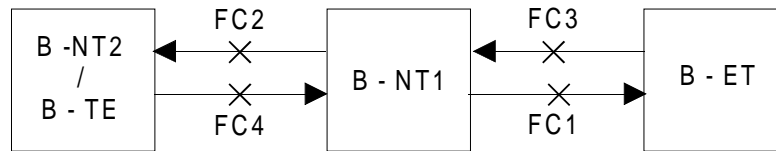

Fault condition	Definition
FC4	Fault in the upstream direction of the interface.
FC2	Fault in the downstream direction of the interface.
FC3	Fault in the downstream direction in access digital section.
FC1	Fault in the upstream direction in access digital section.

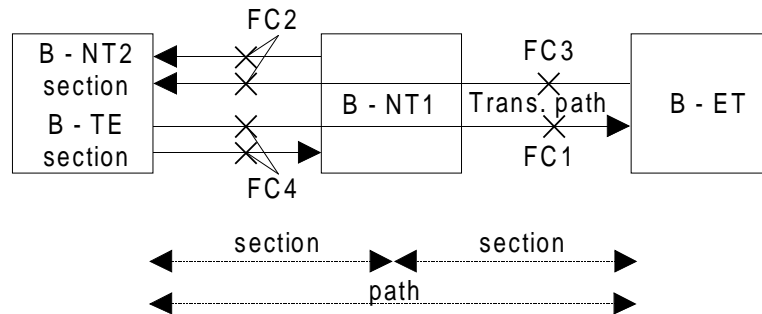

Figure 14: Fault conditions and operational span of section path maintenance signals

Table 4: F-State table: physical layer 1 state matrix at the user side (note 1)

	Initial state	F0	F1	F2	F3	F4	F5	F6	F7
Definition of the states	Operational condition or fault condition	Power off at user side	Operational	FC1	FC2 fault conditions - (note 2)	FC3 or FC1 & FC3	FC4 or FC4 & FC1	FC3 & FC4 or FC3 & FC4 & FC1	Power on at user side
	Signal transmitted by user towards interface	No signal	Normal operational cells	Normal operational cells	physical layer OAM cells with S-RDI & P-RDI	physical layer OAM cells with P-RDI	Normal operational cells	physical layer OAM cells with P-RDI	No signal
New event detected at receiving side	Loss of power at user side	/	PH-DI MPH-EI0 F0	MPH-EI0 F0	MPH-EI0 F0	MPH-EI0 F0	MPH-EI0 F0	MPH-EI0 F0	MPH-EI0 F0
	Return of power to user side	F7	/	/	/	/	/	/	/
	Normal operational cells from network side	/	-	PH-AI MPH-AI F1	PH-AI MPH-AI F1	PH-AI MPH-AI F1	PH-AI MPH-AI F1	PH-AI MPH-AI F1	PH-AI MPH-AI F1
	P-RDI (FC1)	/	PH-DI MPH-EI1 F2	-	ndp	-	-	-	MPH-EI1 F2
	LOS or LCD (FC2) (note 3)	/	PH-DI MPH-EI2 F3	MPH-EI2 F3	-	MPH-EI2 F3	MPH-EI2 F3	MPH-EI2 F3	MPH-EI2 F3
	P-AIS (FC3) or (FC1&FC3) (note 4)	/	PH-DI MPH-EI3 F4	MPH-EI3 F4	ndp	-	MPH-EI3 F4	-	MPH-EI3 F4
	P-RDI and S-RDI (FC4)	/	PH-DI MPH-EI4 F5	MPH-EI4 F5	ndp	MPH-EI4 F5	-	-	MPH-EI4 F5
	P-AIS & S-RDI & P-RDI	/	PH-DI MPH-EI3 MPH-EI4 F6	MPH-EI3 MPH-EI4 F6	ndp	MPH-EI4 F6	MPH-EI3 F6	-	MPH-EI3 & 4 F6

- NOTE 1: If the path trace is used, the path trace mismatch related failure as LCD. In this table "LCD" will be substitute by "LCD or path trace mismatch".
- NOTE 2: The user side cannot distinguish among FC2, FC2+FC1, FC2+FC3, FC2+FC4, FC2+FC1+FC3, FC2+FC1+FC4, FC2+FC3+FC4 or FC2+FC1+FC3+FC4.
- NOTE 3: When FC2 occurs, other fault conditions (FC1 or FC3 or FC4) can not be detected but they may occur simultaneously.
- NOTE 4: When FC3 occurs, FC1 (P-RDI) cannot be detected but it may occur simultaneously.

Table 5: G-state table: physical layer 1 state matrix at the network side

	Initial state	G0	G1	G2	G3	G4	G5	G6	G7	G8	G9	G10	G11	G12	G13
Definition of the states	Operation condition or failure condition	Power off at NT1	Operational	FC1	FC2	FC3	FC4 or FC2 & FC4	FC1 & FC2	FC1 & FC3	FC1 & FC4 or FC1 & FC2 & FC4	FC2 & FC3	FC3 & FC4 or FC2 & FC3 & FC4	FC1 & FC2 & FC3	FC1 & FC3 & FC4 or FC1 & FC2 & FC3 & FC4	Power on at NT1
	Signal transmitted towards interface	No signal	Normal operational signal	Signal with P-RDI	Normal operational signal	Signal with P-AIS	Signal with S-RDI & P-RDI	Signal with P-RDI	Signal with P-AIS	Signal with S-RDI & P-RDI	Signal with P-AIS	Signal with P-AIS & S-RDI	Signal with P-AIS	Signal with P-AIS & S-RDI & P-RDI	No signal
New detected event	Loss of power or powerdown mode at NT1	-	PH-DI MPH-EI0 G0	MPH-EI0 G0	MPH-EI0 G0	MPH-EI0 G0	MPH-EI0 G0	MPH-EI0 G0	MPH-EI0 G0	MPH-EI0 G0	MPH-EI0 G0	MPH-EI0 G0	MPH-EI0 G0	MPH-EI0 G0	MPH-EI0 G0
	Return of power at NT1	MPH-CI0 G13	/	/	/	/	/	/	/	/	/	/	/	/	/
	Normal operational cells	/	-	PH-AI MPH-AI G1	PH-AI MPH-AI G1	PH-AI MPH-AI G1	PH-AI MPH-AI G1	PH-AI MPH-AI G1	PH-AI MPH-AI G1	PH-AI MPH-AI G1	PH-AI MPH-AI G1	PH-AI MPH-AI G1	PH-AI MPH-AI G1	PH-AI MPH-AI G1	PH-AI MPH-AI G1
New appearing event	Internal network failure FC1	/	PH-DI MPH-EI1 G2	-	MPH-EI1 G6	MPH-EI1 G7	MPH-EI1 G8	-	-	-	MPH-EI1 G11	MPH-EI1 G12	-	-	MPH-EI1 G2
	Reception of S-DR _I & P-RDI _I (FC2)	/	PH-DI MPH-EI2 G3	MPH-EI2 G6	-	MPH-EI2 G9	n.d.p.	-	MPH-EI2 G11	n.d.p.	-	n.d.p.	-	n.d.p.	MPH-EI2 G3
	Internal network failure FC3 (note)	/	PH-DI MPH-EI3 G4	MPH-EI3 G7	MPH-EI3 G9	-	MPH-EI3 G10	MPH-EI3 G11	-	MPH-EI3 G12	-	-	-	-	MPH-EI3 G4
	LOS, LCD or LOM (FC4)	/	PH-DI MPH-EI4 G5	MPH-EI4 G8	MPH-EI4 G5	MPH-EI4 G10	-	MPH-EI4 G8	MPH-EI4 G12	-	MPH-EI4 G10	-	MPH-EI4 G12	-	MPH-EI4 G5
Dis-appearing FC	FC1	/	/	MPH-CI1 G1	/	/	/	MPH-CI1 G3	MPH-CI1 G4	MPH-CI1 G5	/	/	MPH-CI1 G9	MPH-CI1 G10	/
	FC2	/	/	/	MPH-CI2 G1	/	-	MPH-CI2 G2	/	-	MPH-CI2 G4	-	MPH-CI2 G7	-	/
	FC3	/	/	/	/	MPH-CI3 G1	/	/	MPH-CI3 G2	/	MPH-CI3 G3	MPH-CI3 G5	MPH-CI3 G6	MPH-CI3 G8	/
	FC4	/	/	/	/	/	MPH-CI4 G3	/	/	MPH-CI4 G6	/	MPH-CI4 G9	/	MPH-CI4 G11	/

NOTE: If FC3 represents a path related fault condition (e.g. LCD), the consequent reaction is not applicable for the state table, because this failure can not be recognized at the network side. Therefore, no state change will occur.

Annex A (informative): Impact of random bit errors on cell delineation performance

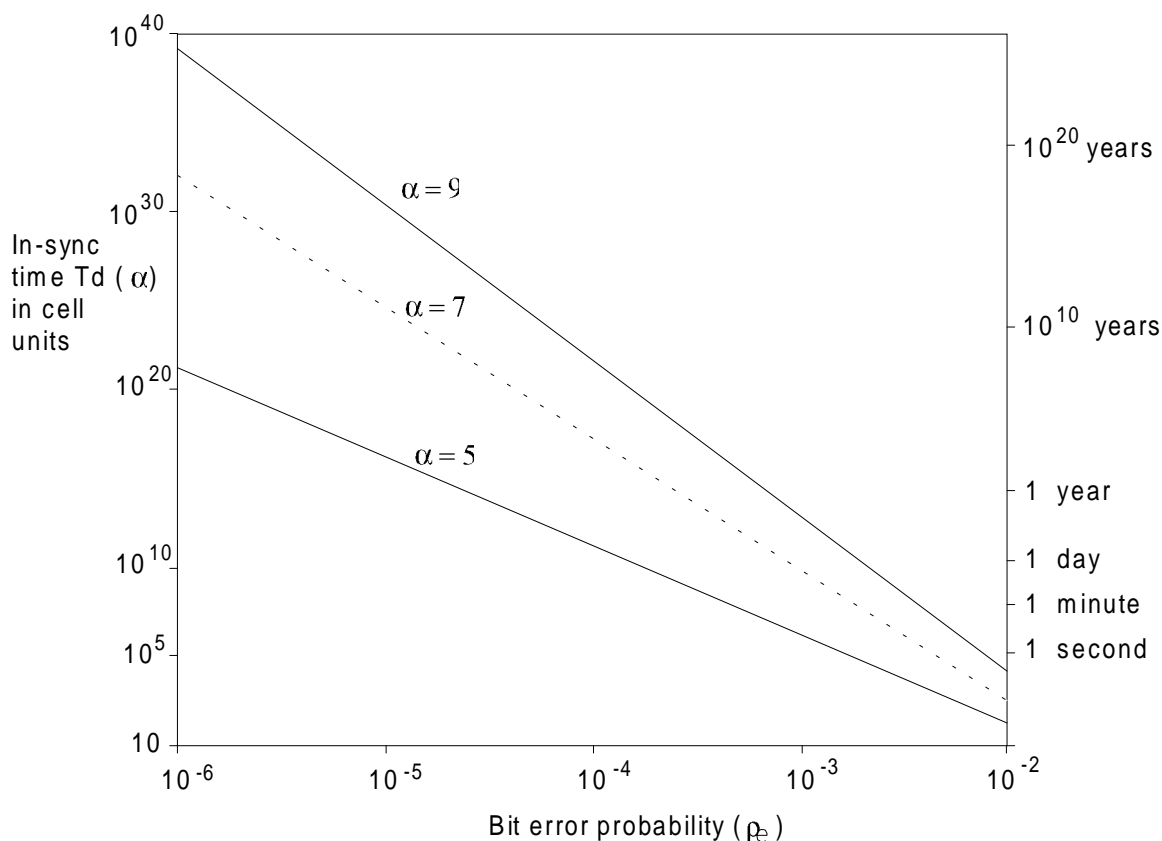

Figure A.1: In-sync time vs. bit error probability ($T_d(\alpha)$ vs. r_e)

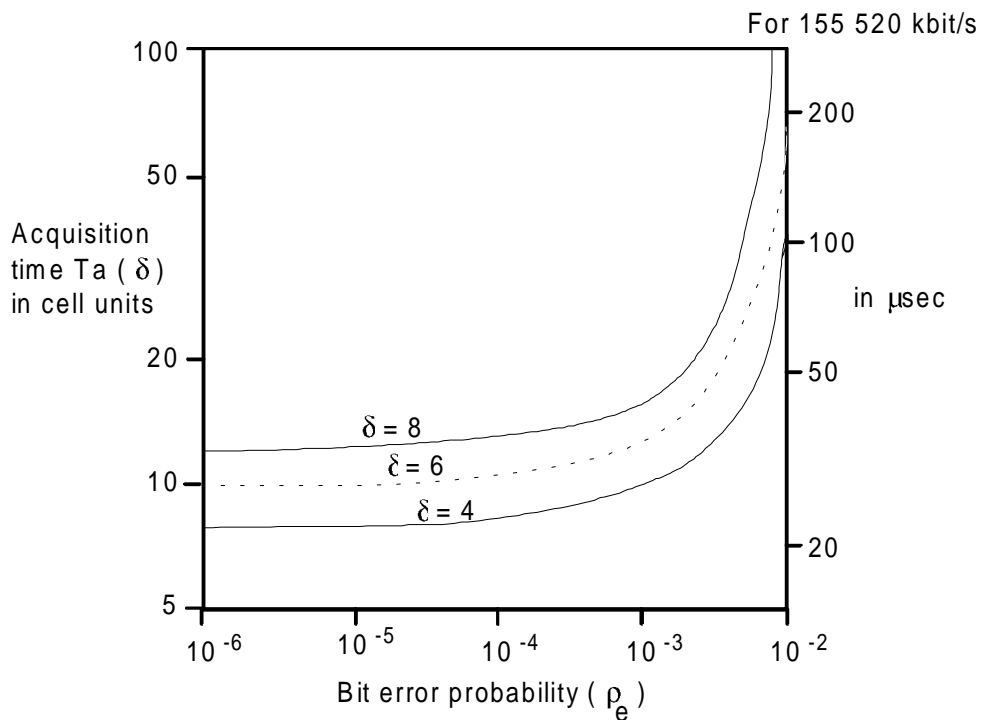

Figure A.2: Acquisition time vs. bit error probability ($T_a(\delta)$ vs. r_e)

Annex B (informative): Distributed sample scrambler descrambler implementation example

Acquisition of scrambler synchronization

The conveyed bits are extracted by modulo addition of the predicted values for HEC₈ and HEC₇ from the received values. Scrambler synchronization may, for example, be achieved by applying the conveyed samples at half cell intervals to a recursive descrambler (figure B.1). In order to ensure the samples are added into the recursive descrambler at the same interval they were extracted from the source Pseudo-Random Binary Sequence (PRBS), the second sample U_(t+1) (derived from HEC₇) is stored for 211 bits before it is used.

Additionally, because both samples are applied to the recursive descrambler 211 bits behind their point of modulo addition to the transmitted data sequence, the recursive descrambler feed-forward taps are chosen to generate a sequence that is advanced by 211 samples. Similarly, the verification comparison made in the recursive descrambler between the conveyed bits and their prediction is delay equalized using one bit stores as illustrated in figure B.1.

Example: Implementation: the recursive descrambler.

Figure B.1 illustrates the recursive descrambler implementation. Notation of sample values indicates the important sample values in each cell, time being referenced to the conveyed PRBS sample being received with HEC₈.

At time t:

- the receiver PRBS generator sample V_t is at the input to the lower D-type D₂;
- the source PRBS sample S_t = U_{t-211} conveyed via HEC₈ is at input D₁;
- the sample previously stored at the output of the lower D-type is D₂ = V_{t-211}

$$\text{EXOR}_2 = S_t + D_2 = U_{t-211} + V_{t-211}.$$

The multiplexer selects this output and it is applied to the feed-forward taps of the recursive descrambler.

At time t+1:

- the receiver sample V_{t+1} is at the input to D₂;
- the sample S_{t+1} = U_{t+1} is at the input to D₁.

These values are latched on the following clock edge such that:

at time t+2 through until t+212:

- EXOR₁ = V_{t+1} + U_{t+1} which is applied via MUX at time t+212 to the feed-forward taps;

at time t+213 = L+t-211 (L being the duration of a cell):

- D₂ = V_{t+213} = V_{t-211+L} (held until the next cell cycle).

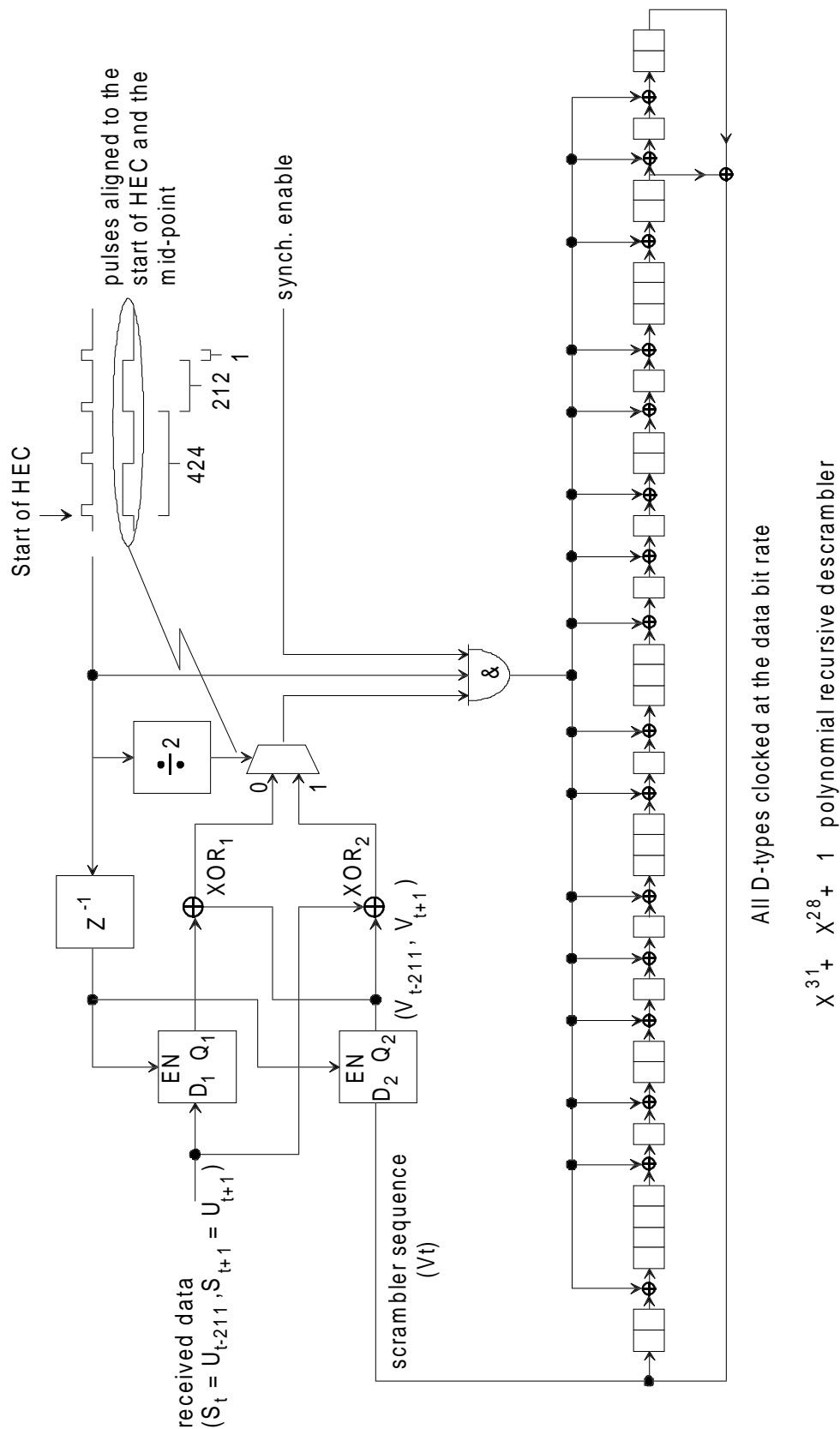

Figure B.1: Recursive descrambler implementation

History

Document history	
February 1995	Second Edition
June 1996	Public Enquiry PE 107: 1996-06-03 to 1996-09-27