



**E**UROPEAN  
**T**ELECOMMUNICATION  
**S**TANDARD

**DRAFT**  
pr **ETS 300 267-4**

April 1997

---

Source: ETSI TC-SPS

Reference: DE/SPS-05048-4

ICS: 33.020

**Key words:** ISDN, DSS1, teleservice, 7 kHz, video, telephony, testing, ATS, PIXIT, user

**Integrated Services Digital Network (ISDN);  
Telephony 7 kHz and videotelephony teleservices;  
Digital Subscriber Signalling System No. one (DSS1) protocol;  
Part 4: Abstract Test Suite (ATS) and partial Protocol  
Implementation eXtra Information for Testing (PIXIT) proforma  
specification for the user**

**ETSI**

European Telecommunications Standards Institute

**ETSI Secretariat**

**Postal address:** F-06921 Sophia Antipolis CEDEX - FRANCE

**Office address:** 650 Route des Lucioles - Sophia Antipolis - Valbonne - FRANCE

**X.400:** c=fr, a=atlas, p=etsi, s=secretariat - **Internet:** secretariat@etsi.fr

Tel.: +33 4 92 94 42 00 - Fax: +33 4 93 65 47 16

---

**Copyright Notification:** No part may be reproduced except as authorized by written permission. The copyright and the foregoing restriction extend to reproduction in all media.

© European Telecommunications Standards Institute 1997. All rights reserved.



## Contents

|   |    |
|---|----|
| Foreword .....                                      | 7  |
| 1 Scope .....                                       | 9  |
| 2 Normative references .....                        | 9  |
| 3 Definitions and abbreviations .....               | 10 |
| 3.1 Definitions .....                               | 10 |
| 3.2 Abbreviations .....                             | 10 |
| 4 Introduction.....                                 | 11 |
| 5 Abstract Test Method (ATM) .....                  | 11 |
| 5.1 Description of ATM used .....                   | 11 |
| 5.2 Conventions for test components and PCOs.....   | 11 |
| 5.3 Description of PCOs .....                       | 12 |
| 5.3.1 D-channel PCO .....                           | 12 |
| 5.3.2 B-channels PCOs.....                          | 13 |
| 5.4 Naming conventions .....                        | 13 |
| 5.4.1 Test cases.....                               | 13 |
| 5.4.2 Variables and parameters .....                | 14 |
| 5.4.3 Trees and subtrees .....                      | 14 |
| 6 Untestable test purposes.....                     | 14 |
| 7 ATS conventions .....                             | 14 |
| 7.1 Declarations part.....                          | 14 |
| 7.1.1 Type definitions .....                        | 14 |
| 7.1.1.1 Simple type definitions.....                | 14 |
| 7.1.1.2 Structured type definitions .....           | 14 |
| 7.1.1.2.1 TTCN structured type definitions .....    | 14 |
| 7.1.1.2.2 ASN.1 structured type definitions.....    | 15 |
| 7.1.1.3 ASP type definitions.....                   | 15 |
| 7.1.1.3.1 TTCN ASP type definitions .....           | 15 |
| 7.1.1.3.2 ASN.1 ASP type definitions .....          | 15 |
| 7.1.1.4 PDU type definitions .....                  | 15 |
| 7.1.1.4.1 TTCN PDU type definitions.....            | 15 |
| 7.1.1.4.2 ASN.1 PDU type definitions .....          | 16 |
| 7.1.2 Test suite constants .....                    | 16 |
| 7.1.3 Test suite parameters .....                   | 16 |
| 7.1.4 Variables .....                               | 16 |
| 7.1.4.1 Test suite variables.....                   | 16 |
| 7.1.4.2 Test case variables.....                    | 16 |
| 7.1.5 Test suite operation definitions.....         | 16 |
| 7.2 Constraints part.....                           | 17 |
| 7.2.1 Structured type constraint declaration.....   | 17 |
| 7.2.2 ASN.1 type constraint declaration .....       | 17 |
| 7.2.3 ASP type constraint declaration .....         | 17 |
| 7.2.3.1 ASN.1 ASP type constraint declaration ..... | 17 |
| 7.2.3.2 TTCN ASP type constraint declaration.....   | 17 |
| 7.2.4 PDU type constraint declaration.....          | 17 |
| 7.2.4.1 ASN.1 PDU type constraint declaration.....  | 17 |
| 7.2.4.2 TTCN PDU type constraint declaration .....  | 17 |
| 7.2.5 Derived constraints.....                      | 17 |
| 7.2.6 Parameterized constraints.....                | 18 |

|   |   |    |
|---|---|----|
| 7.2.7   | Value assignment .....                  | 18 |
| 7.2.7.1   | Specific values .....                   | 18 |
| 7.2.7.2   | Matching values .....                   | 18 |
| 7.3   | Dynamic part .....                      | 18 |
| 7.3.1   | Test cases .....                        | 18 |
| 7.3.2   | Test steps .....                        | 18 |
| 7.3.3   | Defaults .....                          | 18 |
| 7.3.4   | Synchronization .....                   | 18 |
| 8   | ATS to TP map .....                     | 20 |
| 9   | PCTR conformance .....                  | 20 |
| 10  | PIXIT conformance .....                 | 20 |
| 11  | ATS conformance .....                   | 20 |
| Annex A (normative): Protocol Conformance Test Report (PCTR) proforma ..... |   | 21 |
| A.1   | Identification summary .....            | 21 |
| A.1.1   | Protocol conformance test report .....  | 21 |
| A.1.2   | IUT identification .....                | 21 |
| A.1.3   | Testing environment .....               | 21 |
| A.1.4   | Limits and reservations .....           | 22 |
| A.1.5   | Comments .....                          | 22 |
| A.2   | IUT Conformance status .....            | 22 |
| A.3   | Static conformance summary .....        | 22 |
| A.4   | Dynamic conformance summary .....       | 22 |
| A.5   | Static conformance review report .....  | 23 |
| A.6   | Test campaign report .....              | 23 |
| A.7   | Observations .....                      | 24 |
| Annex B (normative): Partial PIXIT proforma .....                           |   | 25 |
| B.1   | Identification summary .....            | 25 |
| B.2   | Abstract test suite summary .....       | 25 |
| B.3   | Test laboratory .....                   | 25 |
| B.4   | Client (of the test laboratory) .....   | 26 |
| B.5   | System Under Test (SUT) .....           | 26 |
| B.6   | Protocol information .....              | 27 |
| B.6.1   | Protocol identification .....           | 27 |
| B.6.2   | Configuration to be tested .....        | 27 |
| B.6.3   | Actions required to stimulate IUT ..... | 28 |
| B.6.4   | Test management timers .....            | 28 |
| B.6.5   | Parameter values .....                  | 29 |

Annex C (normative):    Abstract Test Suite (ATS).....30

C.1    The TTCN Graphical form (TTCN.GR) .....30

C.2    The TTCN Machine Processable form (TTCN.MP) .....30

Annex D (informative):    General structure of ATS.....31

History.....32

Blank page

## Foreword

This draft European Telecommunication Standard (ETS) has been produced by the Signalling Protocols and Switching (SPS) Technical Committee of the European Telecommunications Standards Institute (ETSI), and is now submitted for the Public Enquiry phase of the ETSI standards approval procedure.

This ETS is part 4 of a multi-part standard covering the Digital Subscriber Signalling System No. one (DSS1) protocol specification for the Integrated Services Digital Network (ISDN) telephony 7 kHz and videotelephony teleservices, as described below:

- Part 1: "Protocol specification";
- Part 2: "Protocol Implementation Conformance Statement (PICS) proforma specification";
- Part 3: "Test Suite Structure and Test Purposes (TSS&TP) specification for the user";
- Part 4: "Abstract Test Suite (ATS) and partial Protocol Implementation eXtra Information for Testing (PIXIT) proforma specification for the user";**
- Part 5: "TSS&TP specification for the network";
- Part 6: "ATS and partial PIXIT proforma specification for the network".

| <b>Proposed transposition dates</b>   |                                 |
|---|---------------------------------|
| Date of latest announcement of this ETS (doa):  | 3 months after ETSI publication |
| Date of latest publication of new National Standard or endorsement of this ETS (dop/e): | 6 months after doa              |
| Date of withdrawal of any conflicting National Standard (dow):                          | 6 months after doa              |

Blank page



## 1 Scope

This fourth part of ETS 300 267 specifies the Abstract Test Suite (ATS) and partial Protocol Implementation eXtra Information for Testing (PIXIT) proforma for the User side of the T reference point or coincident S and T reference point (as defined in ITU-T Recommendation I.411 [17]) of implementations conforming to the stage three standard of the telephony 7 kHz and videotelephony teleservices for the pan-European Integrated Services Digital Network (ISDN) by means of the Digital Subscriber Signalling System No. one (DSS1) protocol, ETS 300 267-1 [6].

ETS 300 267-3 [8] specifies the Test Suite Structure and Test Purposes (TSS&TP) related to this ATS and partial PIXIT proforma specification. Other parts specify the TSS&TP and the ATS and partial PIXIT proforma for the Network side of the T reference point or coincident S and T reference point of implementations conforming to ETS 300 267-1 [6].

## 2 Normative references

This ETS incorporates by dated and undated reference, provisions from other publications. These normative references are cited at the appropriate places in the text and the publications are listed hereafter. For dated references, subsequent amendments to or revisions of any of these publications apply to this ETS only when incorporated in it by amendment or revision. For undated references the latest edition of the publication referred to applies.

- [1] ETS 300 102-1: "Integrated Services Digital Network (ISDN); User-network interface layer 3; Specifications for basic call control".
- [2] ETS 300 143: "Integrated Services Digital Network (ISDN); Audiovisual services; Inband signalling procedures for audiovisual terminals using digital channels up to 2 048 kbit/s".
- [3] ETS 300 144: "Integrated Services Digital Network (ISDN); Audiovisual services; Frame structure for a 64 kbit/s to 1 920 kbit/s channel and associated syntax for inband signalling" (equivalent to ITU-T Recommendation H.221).
- [4] ETS 300 145: "Integrated Services Digital Network (ISDN); Audiovisual services; Videotelephone systems and terminal equipment operating on one or two 64 kbit/s channels".
- [5] ETS 300 196-1: "Integrated Services Digital Network (ISDN); Generic functional protocol for the support of supplementary services; Digital Subscriber Signalling System No. one (DSS1) protocol; Part 1: Protocol specification".
- [6] ETS 300 267-1 (1994) including A1 (1996): "Integrated Services Digital Network (ISDN); Telephony 7 kHz and videotelephony teleservices; Digital Subscriber Signalling System No. one (DSS1) protocol; Part 1: Protocol specification".
- [7] ETS 300 267-2 (1996): "Integrated Services Digital Network (ISDN); Telephony 7 kHz and videotelephony teleservices; Digital Subscriber Signalling System No. one (DSS1) protocol; Part 2: Protocol Implementation Conformance Statement (PICS) proforma specification".
- [8] ETS 300 267-3: "Integrated Services Digital Network (ISDN); Telephony 7 kHz and videotelephony teleservices; Digital Subscriber Signalling System No. one (DSS1) protocol; Part 3: Test Suite Structure and Test Purposes (TSS&TP) specification for the user".
- [9] ETS 300 403-1 (1995): "Integrated Services Digital Network (ISDN); Digital Subscriber Signalling System No. one (DSS1) protocol; Signalling network layer for circuit-mode basic call control; Part 1: Protocol specification [ITU-T Recommendation Q.931 (1993), modified]".

- [10] ETS 300 403-5: "Integrated Services Digital Network (ISDN); Digital Subscriber Signalling System No. one (DSS1) protocol; Signalling network layer for circuit-mode basic call control; Part 5: Abstract Test Suite (ATS) and partial Protocol Implementation eXtra Information for Testing (PIXIT) proforma specification for the user".
- [11] I-ETS 300 763-2: "Integrated Services Digital Network (ISDN); Audiovisual services in-band signalling testing; Part 2: Abstract Test Suite (ATS) and partial Protocol Implementation eXtra Information for Testing (PIXIT) proforma".
- [12] ISO/IEC 9646-1: "Information technology - OSI Conformance Testing Methodology and Framework; Part 1: General Concepts".
- [13] ISO/IEC 9646-2: "Information technology - OSI Conformance Testing Methodology and Framework; Part 2: Abstract Test Suite Specification".
- [14] ISO/IEC 9646-3: "Information technology - OSI Conformance Testing Methodology and Framework; Part 3: The Tree and Tabular Combined Notation".
- [15] ISO/IEC 9646-4: "Information technology - OSI Conformance Testing Methodology and Framework; Part 4: Test realization".
- [16] ISO/IEC 9646-5: "Information technology - OSI Conformance Testing Methodology and Framework; Part 5: Requirements on test laboratories and clients for the conformance assessment process".
- [17] ITU-T Recommendation I.411 (1993): "ISDN user-network interfaces - Reference configurations".

### 3 Definitions and abbreviations

#### 3.1 Definitions

For the purposes of this ETS, the definitions given in ETS 300 267-1 [6] and ISO/IEC 9646, parts 1 [12] to 5 [16] and the following definitions apply:

**additional B-channel:** The second or subsequent B-channel established in a videotelephony call.

**initial B-channel:** The first channel established in a videotelephony call.

#### 3.2 Abbreviations

For the purposes of this ETS, the following abbreviations apply:

|      |                            |
|------|----------------------------|
| ASP  | Abstract Service Primitive |
| ATM  | Abstract Test Method       |
| ATS  | Abstract Test Suite        |
| BAS  | Bit rate Allocation Signal |
| CES  | Connection Endpoint Suffix |
| CM   | Co-ordination Message      |
| CP   | Co-ordination Point        |
| CRC  | Cyclic Redundancy Check    |
| ExTS | Executable Test Suite      |
| FAW  | Frame Alignment Word       |
| IUT  | Implementation Under Test  |
| LT   | Lower Tester               |

|       |   |
|-------|---|
| MOT   | Means Of Testing                                      |
| MTC   | Main Test Component                                   |
| PCO   | Point of Control and Observation                      |
| PCTR  | Protocol Conformance Test Report                      |
| PDU   | Protocol Data Unit                                    |
| PICS  | Protocol Implementation Conformance Statement         |
| PIXIT | Protocol Implementation eXtra Information for Testing |
| PTC   | Parallel Test Component                               |
| SUT   | System Under Test                                     |
| TP    | Test Purpose  |
| TSS   | Test Suite Structure                                  |
| TTCN  | Tree and Tabular Combined Notation                    |
| UT    | Upper Tester  |

## 4 Introduction

Implementations Under Test (IUTs) which are to be tested using this ATS are required to have previously been tested for conformity against and passed the test suites for ETS 300 102-1 [1] or ETS 300 403-1 [9], and the ATS related to ETS 300 143 [2], ETS 300 144 [3] and ETS 300 145 [4] which is contained in I-ETS 300 763-2 [11].

Any messages or fields within messages which are introduced by ETS 300 403-1 [9] are included in this ATS. Behaviours in test cases have been described in such a way to be able to take into account both ETS 300 102-1 [1] and ETS 300 403-1 [9] basic call standards. This ATS also takes into account messages defined for the supplementary services, in particular ETS 300 196-1 [5]. When such messages are received, they are ignored by the ATS as this is not within the scope of this ETS.

## 5 Abstract Test Method (ATM)

### 5.1 Description of ATM used

This ATS describes the testing specification of the protocol procedures and switching functions needed to support the videotelephony and telephony 7 kHz teleservices at T or coincident S and T reference points for the user.

Testing activity will take place on the D-channel and on one or two B-channels depending on which teleservice is supported and where the service is provided. The videotelephony teleservice can imply up to two B-channels and telephony 7 kHz teleservice up to one B-channel. Only S and T reference point has an associated in-band protocol entity and has to follow requirements on B-channels.

As a consequence of testing multiple channels simultaneously, the concurrent testing method is used. A test configuration includes at least a master test component, a Parallel Test Component (PTC) for the D-channel and eventually one or two PTCs for each involved B-channel. No actual testing is performed by the Main Test Component (MTC), as all Points of Control and Observation (PCOs) are on the PTCs. The remote test method as defined in ISO/IEC 9646-2 [13] is applied in each PTC.

### 5.2 Conventions for test components and PCOs

Figure 1 shows a logical view of the complete configuration of the MTC, PTCs, and PCOs. The Co-ordination Point (CP) relationships between the various components are also indicated. The test method used is very close to the test method used in I-ETS 300 763-2 [11].

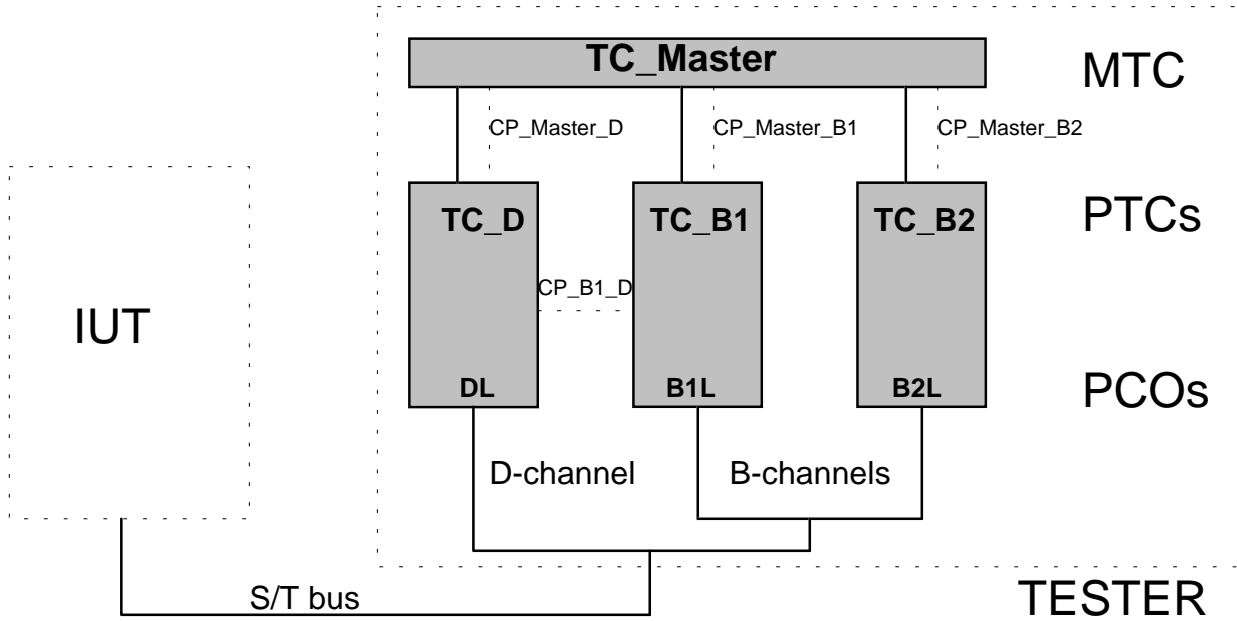

Figure 1: Multi-party test method

In a master/slave arrangement, the MTC is considered to be the master while the PTCs are the slaves.

There are communication paths or CPs between the MTC and each PTC, and also between D-channel PTC and the initial B-channel PTC. The MTC handles all scheduling of test components and exchanges messages with PTCs to start or to stop the running of their associated tree. Messages between TC\_D and TC\_B1 concern more functional synchronization like advising the initial B-channel that it can expand the mode on two B-channels when the additional B-channel is set up by the TC\_D.

5.3 Description of PCOs

The PCOs are used to control and observe the behaviour of the IUT. Preliminary test case verdicts are assigned depending on the behaviour observed at those points. The final verdict is set by the MTC at the end of the test.

5.3.1 D-channel PCO

For the D-channel, the PCO resides at the service access point between layers 2 and 3. This PCO is named "DL" (L for Lower). The same Abstract Service Primitives (ASPs) as defined in ETS 300 403-5 [10] are used.

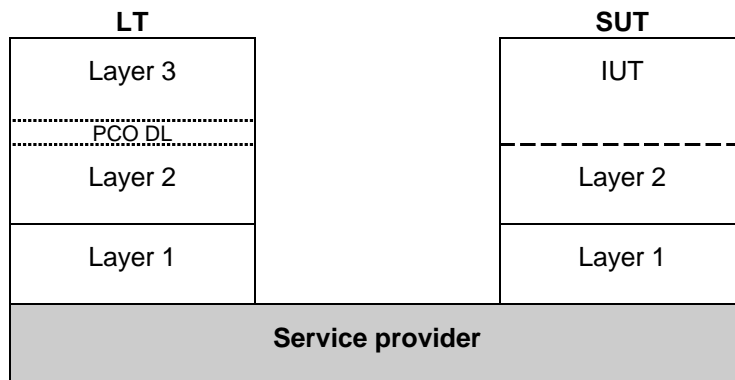

Figure 2: Remote test method

### 5.3.2 B-channels PCOs

For the in-band signalling protocol there is no explicit layered structure. However, there is an implicitly defined structure: a lower layer dealing with frame and multiframe structure, bit encoding of BAS codes and their corresponding CRC codes, FAW etc., and a higher layer dealing with the various sequences and procedures which make use of BAS codes to control the communication.

Lower layer PCOs and the corresponding declarations have been reused from the ATS specified in I-ETS 300 763-2 [11]. When a test case needs description behaviour at a higher layer which cannot be easily expressed at a lower layer, e.g. a complete initialization procedure, and because it is not the purpose of this ATS to check in-band signalling, references to the test step included in the ATS specified in I-ETS 300 763-2 [11] are made instead of importing all of the ASN.1 descriptions.

The audio and video signal contents in the frames and multiframes are ignored. Audio encoding/decoding is out of scope of this ETS and requires specific test tools. As it is not possible to analyse the unframed mode, this is not described in this ETS.

In the B-channel, frames or multiframes are required to be sent and received continuously to maintain frame alignment and this is achieved by looping until the expected frame or multiframe is received or the timer expires.

A procedure for the detection of incorrect CRC4 is described in this ATS. This depends on the detection of an ASP which is generated when the tester implements CRC4 and detects incorrect bit values in bits C1-C4.

## 5.4 Naming conventions

### 5.4.1 Test cases

Test cases have exactly the same reference as the corresponding combined test purpose, see ETS 300 267-3 [8].

The structure of a test case identifier is as follows:

|  |   |
|--|---|
| CT<digit><digit><digit>_<digit><digit> | test case covering a telephony 7 kHz requirement; |
| CV<digit><digit><digit>_<digit><digit> | test case covering a videotelephony requirement.  |

The digits correspond to the digits of the first Test Purpose (TP) included in the combined TP. The TPs are ordered:

- a) by type of requirement (i.e. generic, telephony 7 kHz or videotelephony);
- b) by a three digit number which specifies the relevant position in the Test Suite Structure (TSS):
  - the first digit refers to the second test group level:
    - 1 for Calling user interface (ORIG);
    - 2 for Called user interface (DEST);
  - the second digit refers to the third test group level:
    - 1 Valid behaviour (BV);
    - 2 Invalid behaviour (BI);
    - 3 Inopportune behaviour (BO);
  - the third digit refers to the fifth test group level:
    - 1 Fallback allowed (FBA);
    - 2 Fallback not allowed (FBN);
    - 3 Connection management (CMN);
- c) by a two digit sequence number:

the sequence number follows the order in which the TPs appear in the third level of the TSS.

## 5.4.2 Variables and parameters

Variables used in PTCs associated to B-channels are prefixed by the letter B.

TC\_D

---

|                |        |  |
|----------------|--------|--|
| call reference | CREF   |  |
| channel nr     | B_CHN1 |  |
| call reference | CREF2  |  |
| channel nr     | B_CHN2 |  |

## 5.4.3 Trees and subtrees

Test case trees and subtrees are prefixed by "d\_" when they describe the behaviour at PTC TC\_D, by "b1\_" for PTC TC\_B1 and "b2\_" for PTC TC\_B2.

Test step names use upper case letters and local subtrees use lower case letters.

Preamble subtrees are prefixed by "PR\_" and postamble subtrees by "PO\_".

## 6 Untestable test purposes

Combined TPs correspond only to testable TPs and are all covered by the ATS.

TPs for generic protocol requirements do not correspond to specific protocol behaviour and only describe parts of ETS 300 267-1 [6] which support the telephony 7 kHz and videotelephony teleservices. These TPs have been considered as untestable. Furthermore, TPs which test an unframed mode in the B-channel or an internal behaviour of the IUT have also been considered as untestable.

## 7 ATS conventions

This clause is structured similarly to the structure of a TTCN ATS. However, the names of the subclauses are arranged in a way more suitable to this ETS.

### 7.1 Declarations part

#### 7.1.1 Type definitions

##### 7.1.1.1 Simple type definitions

Where appropriate, simple types have a length, a value list or a range restriction attached.

Simple types defined as being of some string type (e.g. BITSTRING, OCTETSTRING), have a length restriction or a value list attached.

Simple types, defined as being of INTEGER type, have a value list or a range restriction attached.

##### 7.1.1.2 Structured type definitions

###### 7.1.1.2.1 TTCN structured type definitions

All structured type definitions are provided with a full name.

All elements in every structured type definition, defined as being of some string type (e.g. BITSTRING, OCTETSTRING), have a length restriction attached.

If an element in a structured type definition is defined as being of a referenced type, the (possible) restriction is defined in that referenced type.

For information elements, the identifier which is unique for each element, has its type defined as a simple type where the value list is restricted to the single value which is the identifier itself. This has the advantage that it allows a test system derived from this ATS to easily identify information elements embedded in messages. An ATS where information element identifiers are represented as unrestricted types can present difficulties for a derived test system in the case where it needs to find one information element embedded in a number of others and the constraints for the other elements have the any-or-omit value. In such a case the test system cannot easily find the beginning of each information element.

#### 7.1.1.2.2 ASN.1 structured type definitions

There are no ASN.1 structured type definitions in the ATS.

#### 7.1.1.3 ASP type definitions

##### 7.1.1.3.1 TTCN ASP type definitions

TTCN ASP type definitions only contain one PDU or no PDU at all.

All TTCN ASP type definitions are provided with a full identifier.

Some ASPs are not parameterized as shown in the example in table 1. Such ASPs are only used for requesting or receiving service from the B-channel lower layer.

**Table 1: TTCN ASP type definition SEND\_UNFRAMED**

| TTCN ASP Type Definition  |                |          |
|---|----------------|----------|
| ASP NAME : SEND_UNFRAMED  |                |          |
| PCO Type : BSAP   |                |          |
| Comments : Tester will send in unframed mode continuously until another send event occurs |                |          |
| Parameter Name  | Parameter Type | Comments |
| Detailed Comments :   |                |          |

Table 2 shows an example of a parameterized ASP. All ASPs containing PDUs contain only that PDU and no other parameters.

**Table 2: TTCN ASP type definition DL\_DATA\_RQ**

| TTCN ASP Type Definition                  |                |          |
|---|----------------|----------|
| ASP NAME : DL_DAT_RQ<br>(DL_DATA_REQUEST) |                |          |
| PCO Type : DSAP                           |                |          |
| Comments :                                |                |          |
| Parameter Name                            | Parameter Type | Comments |
| mun (MessageUnit)                         | PDU            |          |
| Detailed Comments :                       |                |          |

To make TTCN more readable, aliases have been defined for ASPs.

#### 7.1.1.3.2 ASN.1 ASP type definitions

There are no ASN.1 ASP type definitions in the ATS.

#### 7.1.1.4 PDU type definitions

##### 7.1.1.4.1 TTCN PDU type definitions

The TTCN PDU type reflects the actual data being transferred or received. All PDUs for the D-channel are embedded in ASPs. For the B-channel, because no ASP has been defined for the in-band signalling protocol, frames or multiframes are sent and received on their own.

A meta-type ASP has been defined for all messages which do not require the fields inside to be referenced. This meta-type ASP carries the parameter type PDU. There is one meta-type ASP for send events and one for receive events, named DL\_DAT\_RQ and DL\_DAT\_IN, respectively. If certain fields of a PDU have to be referenced, then a particular ASP type has been defined for that message. For

example, the call reference of an outgoing SETUP message needs to be read by the tester and therefore the ASP type DL\_DAT\_IN\_SETUP has been defined for this event.

**7.1.1.4.2 ASN.1 PDU type definitions**

There are no ASN.1 PDU type definitions in the ATS.

**7.1.2 Test suite constants**

Each test suite constant is defined in terms of a predefined type. The values given in the value column will remain unchanged throughout the ATS.

**7.1.3 Test suite parameters**

Each test suite parameter is defined in terms of a predefined type or a referenced type. A referenced type is used when it is necessary to attach restrictions to these type definitions (it is not allowed to include restrictions directly in the test suite parameter table). The referenced type can have a length or value restriction attached to it in its declaration table.

**7.1.4 Variables**

**7.1.4.1 Test suite variables**

In concurrent TTCN these kind of variables can be used only by the MTC. To check that the IUT can achieve synchronization in a two B-channel communication, a shared counter is needed in order to send multiframes with the same numbering in both B-channels. PTCs TC\_B1 and TC\_B2, corresponding to each B-channel, are located on the same machine. Therefore, the test suite variables B\_SEMAPHORE, B\_SMF\_COUNTER and B\_SMF\_ADDC\_COUNTER can be accessed by both PTCs. The B\_SEMAPHORE variable is used to prevent that the two PTCs update the B\_SMF\_ADDC\_COUNTER simultaneously. B\_SMF\_COUNTER and B\_SMF\_ADDC\_COUNTER correspond to the counters for sub-multiframes sent in the initial and the additional B-channels, respectively.

**7.1.4.2 Test case variables**

Each test case variable is defined in terms of a predefined type or a referenced type. A referenced type is used when it is necessary to attach restrictions to these type definitions (it is not allowed to include restrictions directly in the test case variable table). The referenced type can have a length or value restriction attached to it in its declaration table.

Where test case variables are used in constraints, they are passed as formal parameters.

**7.1.5 Test suite operation definitions**

The description part of a test suite operation definition uses either natural language or meta C.

**Table 3: Test suite operation definition ASSIGN\_CHI**

| Test Suite Operation Definition  |   |
|--|---|
| <b>Operation Name</b>  | ASSIGN_CHI(basic, primary : CHI; basic_flag : BOOLEAN)  |
| <b>Result Type</b>   | CHI   |
| <b>Comments</b>  | This operation is used to assign a correct Channel identification information element to PDUs dependent on the type of access that is tested. |
| Description  |   |
| CHI ASSIGN_CHI(basic,primary,basic_flag)   |   |
| If the value of the basic_flag is set to TRUE, the result of the operation ASSIGN_CHI will be the value represented by the parameter basic which is of type CHI. Else the operation results in the value represented by the parameter primary. |   |
| Examples:<br>ASSIGN_CHI(CHI1b_R1, CHI1p_R1, TRUE) = CHI1b_R1<br>ASSIGN_CHI(CHI1b_R1, CHI1p_R1, FALSE) = CHI1p_R1   |   |
| <b>Detailed comments</b> :   |   |

The Test Suite Operation Definition shown in table 3 is used in the Constraints Part when assigning an element of type CHI a value. The CHI type can be defined in two ways depending on whether the ATS is



testing Basic or Primary-rate access. To avoid duplicate types and thereby duplicate test cases this operation is used to assign a value to an element of CHI type. It takes three parameters:

```
primary:      a constraint of type CHI valid for primary rate access;
basic:       a constraint of type CHI valid for basic access;
basic_flag:  a Boolean value: TRUE if basic access is applicable, FALSE otherwise.
```

This operation returns the correct constraint according to the Boolean flag basic\_flag. That constraint will then be assigned to the specific element of type CHI.

## 7.2 Constraints part

### 7.2.1 Structured type constraint declaration

For every structured type definition there exists one or more structured type constraint.

### 7.2.2 ASN.1 type constraint declaration

There are no ASN.1 type constraint declarations in the ATS.

### 7.2.3 ASP type constraint declaration

#### 7.2.3.1 ASN.1 ASP type constraint declaration

There are no ASN.1 ASP type constraint declarations in the ATS.

#### 7.2.3.2 TTCN ASP type constraint declaration

The PDUs to be sent or received are passed to the TTCN ASP constraint declarations Ms and Mr as parameters of meta type PDU. Only if values inside a specific PDU have to be referenced, the use of the meta type PDU is not allowed according to ISO/IEC 9646-3 [14]. In such cases different TTCN ASP constraint declarations are used, which are defined to carry only a specific type of PDU (e.g. SETUP). Table 4 shows an example of such a TTCN ASP constraint declaration.

**Table 4: TTCN ASP constraint declaration Sr**

| TTCN ASP Constraint Declaration                           |                 |          |
|---|-----------------|----------|
| Constraint Name : Sr(PARAM: SETUP_PDU)                    |                 |          |
| ASP Type : DL_DAT_IN_SETUP                                |                 |          |
| Derivation Path :   |                 |          |
| Comments : ASP to indicate the receipt of SETUP messages. |                 |          |
| Parameter Name  | Parameter Value | Comments |
| mun   | PARAM           |          |
| Detailed Comments :                                       |                 |          |

All ASP constraints have a specific value for its parameter. No matching symbols are used in ASP constraints.

### 7.2.4 PDU type constraint declaration

#### 7.2.4.1 ASN.1 PDU type constraint declaration

There are no ASN.1 PDU type constraint declarations in the ATS.

#### 7.2.4.2 TTCN PDU type constraint declaration

PDU constraints are used for assigning values or patterns to the data being sent or received.

### 7.2.5 Derived constraints

Derived constraints are used in the ATS for PDUs only.

## 7.2.6 Parameterized constraints

Parameterized constraints are used in the ATS.

## 7.2.7 Value assignment

### 7.2.7.1 Specific values

For specific value assignment both explicit values and references to explicit values are used.

### 7.2.7.2 Matching values

As matching values the following mechanisms are used:

Instead of value:

|           |          |
|-----------|----------|
| AnyOrOmit | "**"     |
| AnyValue  | "?"      |
| SuperSet  | SUPERSET |
| Omit      | "_"      |

Inside value:

|           |      |
|-----------|------|
| AnyOne    | "?"  |
| AnyOrNone | "**" |

## 7.3 Dynamic part

### 7.3.1 Test cases

Each test case contains:

- as purpose, the references to the included test purposes in the corresponding combined test purpose from ETS 300 267-3 [8];
- as comment, a united text of the test purposes;
- as description, the relevant references to ETS 300 267-1 [6];
- as behaviour description, at least a main tree for the MTC and a subtree to describe the behaviour in the D-channel. Depending on the reference point which is tested and the purpose of the test, one or two subtrees specify the behaviour in the B-channels. Subtrees that describe B-channel behaviours are started only to check requirements at the S/T reference point and are created only for an IUT that supports requirements at this reference point.

### 7.3.2 Test steps

Much use has been made of test steps to avoid needless repetition of dynamic behaviour. The MTC behaviour is specified in three test steps which correspond to the three potential test configurations.

Behaviour description for the B-channel always employs test steps so that if the tester does not implement B-channel testing, those test steps could easily be ignored.

### 7.3.3 Defaults

Note the use of the RETURN statement which is defined in DAM1 of ISO/IEC 9646-3 [14]. This allows valid background behaviour to be handled in the default tree with a possibility to return to the original set of alternatives in the test case.

### 7.3.4 Synchronization

If a PTC does not finish after an extra long timer, the MTC stops all active PTCs by sending a Halt message. These co-ordination messages are captured by the PTCs in their default trees and by TC\_D in its postambles.

The MTC waits for co-ordination messages from TC\_D to create TC\_B1's tree and from TC\_B1 to create TC\_B2's tree. On the opposite, TC\_B1 expects, before starting its postamble in a two B-channel communication call, a co-ordination message from the MTC to tell it that TC\_B2 has ended. TC\_D expects, before starting its postamble to free channel(s), a co-ordination message from the MTC to tell it that TC\_B1 has ended.

The PTCs need to exchange co-ordination messages for functional reasons. TC\_B1 cannot expand the communication on both channel until TC\_D has not established the call for the additional channel.

Figure 3 shows which and how co-ordination messages are exchanged in a test case where a two B-channel communication call is established.

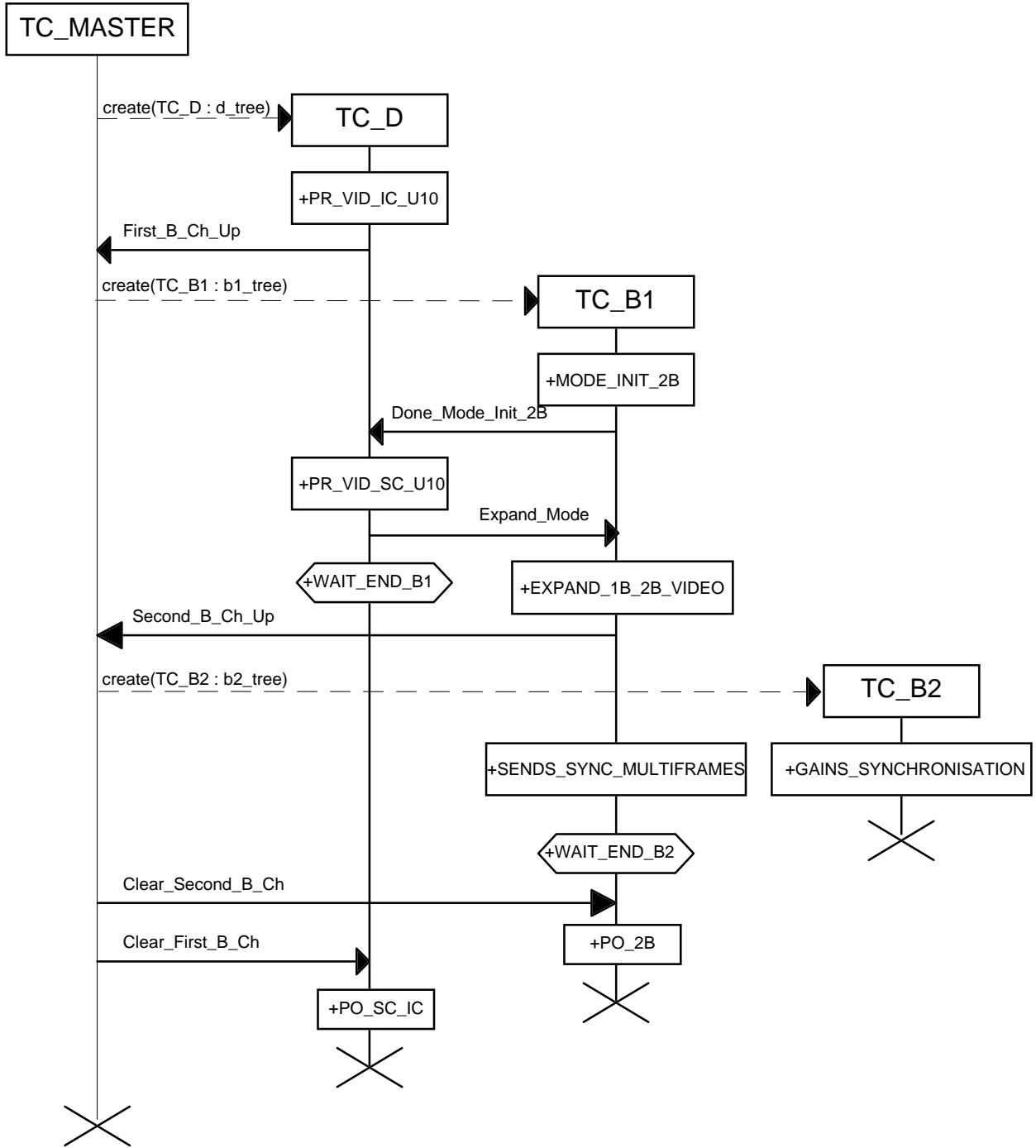

Figure 3: Example of an exchange of co-ordination messages

## 8 ATS to TP map

The identifiers used for the combined TPs are reused as test case names. Thus there is a straightforward one-to-one mapping.

## 9 PCTR conformance

A test laboratory, when requested by a client to produce a PCTR, is required, as specified in ISO/IEC 9646-5 [16], to produce a PCTR conformant with the PCTR template given in annex B of ISO/IEC 9646-5 [16].

Furthermore, a test laboratory, offering testing for the ATS specification contained in annex C, when requested by a client to produce a PCTR, is required to produce a PCTR conformant with the PCTR proforma contained in annex A of this ETS.

A PCTR which conforms to this PCTR proforma specification shall preserve the content and ordering of the clauses contained in annex A. Clause A.6 of the PCTR may contain additional columns. If included, these shall be placed to the right of the existing columns. Text in italics may be retained by the test laboratory.

## 10 PIXIT conformance

A test realizer, producing an executable test suite for the ATS specification contained in annex C, is required, as specified in ISO/IEC 9646-4 [15], to produce an augmented partial PIXIT proforma conformant with this partial PIXIT proforma specification.

An augmented partial PIXIT proforma which conforms to this partial PIXIT proforma specification shall, as a minimum, have contents which are technically equivalent to annex B. The augmented partial PIXIT proforma may contain additional questions that need to be answered in order to prepare the Means Of Testing (MOT) for a particular IUT.

A test laboratory, offering testing for the ATS specification contained in annex C, is required, as specified in ISO/IEC 9646-5 [16], to further augment the augmented partial PIXIT proforma to produce a PIXIT proforma conformant with this partial PIXIT proforma specification.

A PIXIT proforma which conforms to this partial PIXIT proforma specification shall, as a minimum, have contents which are technically equivalent to annex B. The PIXIT proforma may contain additional questions that need to be answered in order to prepare the test laboratory for a particular IUT.

## 11 ATS conformance

The test realizer, producing MOT and ExTS for this ATS specification, shall comply with the requirements of ISO/IEC 9646-4 [15]. In particular, these concern the realization of an ExTS based on each ATS. The test realizer shall provide a statement of conformance of the MOT to this ATS specification.

An ExTS which conforms to this ATS specification shall contain test groups and test cases which are technically equivalent to those contained in the ATS in annex C. All sequences of test events comprising an abstract test case shall be capable of being realized in the executable test case. Any further checking which the test system might be capable of performing is outside the scope of this ATS specification and shall not contribute to the verdict assignment for each test case.

Test laboratories running conformance test services using this ATS shall comply with ISO/IEC 9646-5 [16].

A test laboratory which claims to conform to this ATS specification shall use an MOT which conforms to this ATS.

## Annex A (normative): Protocol Conformance Test Report (PCTR) proforma

Notwithstanding the provisions of the copyright clause related to the text of this ETS, ETSI grants that users of this ETS may freely reproduce the PCTR proforma in this annex so that it can be used for its intended purposes and may further publish the completed PCTR.

### A.1 Identification summary

#### A.1.1 Protocol conformance test report

|                                 |  |
|---------------------------------|--|
| PCTR number:                    |  |
| PCTR date:                      |  |
| Corresponding SCTR number:      |  |
| Corresponding SCTR date:        |  |
| Test laboratory identification: |  |
| Test laboratory manager:        |  |
| Signature:                      |  |

#### A.1.2 IUT identification

|                          |               |
|--------------------------|---------------|
| Name:                    |               |
| Version:                 |               |
| Protocol specification:  | ETS 300 267-1 |
| PICS:                    |               |
| Previous PCTRs (if any): |               |

#### A.1.3 Testing environment

|                                      |   |
|--------------------------------------|---|
| PIXIT reference number:              |   |
| ATS specification:                   | ETS 300 267-4                                       |
| Abstract test method:                | Remote multi-party test method (see ISO/IEC 9646-2) |
| Means of testing identification:     |   |
| Dates of testing:                    |   |
| Conformance log reference(s):        |   |
| Retention date for log reference(s): |   |

**A.1.4 Limits and reservations**

*Additional information relevant to the technical contents or further use of the test report, or to the rights and obligations of the test laboratory and the client, may be given here. Such information may include restriction on the publication of the report.*

.....  
.....  
.....  
.....

**A.1.5 Comments**

*Additional comments may be given by either the client or the test laboratory on any of the contents of the PCTR, for example, to note disagreement between the two parties.*

.....  
.....  
.....  
.....

**A.2 IUT Conformance status**

This IUT has / has not been shown by conformance assessment to be non-conforming to the specified protocol specification.

*Strike the appropriate words in this sentence. If the PICS for this IUT is consistent with the static conformance requirements (as specified in clause A.3 of this report) and there are no "FAIL" verdicts to be recorded (in clause A.6) strike the words "has", otherwise strike the words "has not".*

**A.3 Static conformance summary**

The PICS for this IUT is / is not consistent with the static conformance requirements in the specified protocol.

*Strike the appropriate words in this sentence.*

**A.4 Dynamic conformance summary**

The test campaign did / did not reveal errors in the IUT.

*Strike the appropriate words in this sentence. If there are no "FAIL" verdicts to be recorded (in clause A.6 of this report) strike the word "did", otherwise strike the words "did not".*

Summary of the results of groups of tests:

.....  
.....  
.....  
.....  
.....

**A.5 Static conformance review report**

*If clause A.3 indicates non-conformance, this clause itemizes the mismatches between the PICS and the static conformance requirements of the specified protocol specification.*

.....

.....

.....

.....

.....

.....

.....

.....

**A.6 Test campaign report**

| ATS reference | Selected?<br>(Y/N) | Run?<br>(Y/N) | Verdict | Observations |
|---------------|--------------------|---------------|---------|--------------|
| CT111_01      |                    |               |         |              |
| CT111_02      |                    |               |         |              |
| CT111_03      |                    |               |         |              |
| CT111_04      |                    |               |         |              |
| CT111_05      |                    |               |         |              |
| CT111_06      |                    |               |         |              |
| CT111_07      |                    |               |         |              |
| CT111_08      |                    |               |         |              |
| CT112_01      |                    |               |         |              |
| CT112_02      |                    |               |         |              |
| CT112_03      |                    |               |         |              |
| CT113_01      |                    |               |         |              |
| CT113_02      |                    |               |         |              |
| CV111_01      |                    |               |         |              |
| CV111_02      |                    |               |         |              |
| CV111_03      |                    |               |         |              |
| CV111_04      |                    |               |         |              |
| CV111_05      |                    |               |         |              |
| CV111_06      |                    |               |         |              |
| CV111_07      |                    |               |         |              |
| CV111_08      |                    |               |         |              |
| CV111_09      |                    |               |         |              |
| CV111_10      |                    |               |         |              |
| CV111_11      |                    |               |         |              |
| CV112_01      |                    |               |         |              |
| CV112_02      |                    |               |         |              |
| CV112_03      |                    |               |         |              |
| CV113_01      |                    |               |         |              |
| CV113_02      |                    |               |         |              |
| CV113_03      |                    |               |         |              |
| CV113_04      |                    |               |         |              |
| CV113_05      |                    |               |         |              |
| CV113_07      |                    |               |         |              |
| CV113_08      |                    |               |         |              |

(continued)





**Annex B (normative): Partial PIXIT proforma**

Notwithstanding the provisions of the copyright clause related to the text of this ETS, ETSI grants that users of this ETS may freely reproduce the partial PIXIT proforma in this annex so that it can be used for its intended purposes and may further publish the completed PIXIT.

**B.1 Identification summary**

PIXIT number:

.....

Test laboratory name:

.....

Date of issue:

.....

Issued to:

.....

**B.2 Abstract test suite summary**

Protocol specification: ETS 300 267-1

ATS specification: ETS 300 267-4

Abstract test method: Remote multi-party test method (see ISO/IEC 9646-2)

**B.3 Test laboratory**

Test laboratory identification:

.....

Accreditation status of the test service:

.....

Accreditation reference:

.....

Test laboratory manager:

.....

Test laboratory contact:

.....

Means of testing:

.....

Test laboratory instructions for completion:

.....

## B.4 Client (of the test laboratory)

Client identification:

.....

Client test manager:

.....

Client contact:

.....

Test facilities required:

.....

## B.5 System Under Test (SUT)

Name:

.....

Version:

.....

SCS reference:

.....

Machine configuration:

.....

Operating system identification:

.....

IUT identification:

.....

PICS (all layers):

.....

.....

Limitations of the SUT:

.....

Environmental conditions:

.....

## B.6 Protocol information

### B.6.1 Protocol identification

Specification reference: ETS 300 267-1

Protocol version:

PICS reference:

NOTE: The PICS references should reference a completed PICS which is conformant with the PICS proforma contained in ETS 300 267-2 and the PICS proforma contained in either I-ETS 300 314/I-ETS 300 315 or ETS 300 403-3.

### B.6.2 Configuration to be tested

**Table B.1: Configuration to be tested**

| <b>Item</b> | <b>Configuration</b>  | <b>Supported)<br/>(Y/N)</b> |
|-------------|---|-----------------------------|
| 1.1         | Is the IUT configured for Basic access?<br>(otherwise it is Primary rate access)  |                             |
| 1.2         | If it is a basic access, is the IUT configured<br>in a point-to-point configuration? (otherwise<br>it is a point-to-multipoint configuration) |                             |
| 1.3         | Does the IUT send a RESTART message<br>after the establishment of the multiple frame<br>operation ?   |                             |

**B.6.3 Actions required to stimulate IUT**

**Table B.2: Configuration options**

| <b>Item</b> | <b>Configuration:<br/>What actions, if possible, have to be taken to configure the IUT to ...</b>   | <b>Supported?<br/>(Y/N)</b> | <b>Stimulus (action taken)</b> |
|-------------|---|-----------------------------|--------------------------------|
| 2.1         | send a fallback not allowed SETUP message?  |                             |                                |
| 2.2         | fallback to 3,1 kHz teleservice at S/T reference point on receipt of a 7 kHz fallback allowed SETUP message (this point will correspond to an outside point for a private ISDN)?          |                             |                                |
| 2.3         | fallback to 3,1 kHz teleservice at S/T reference point on receipt of a videotelephony fallback allowed SETUP message (this point will correspond to an outside point for a private ISDN)? |                             |                                |
| 2.4         | fallback to 3,1 kHz teleservice at S/T reference point on receipt of a videotelephony fallback allowed SETUP message (this point will correspond to an outside point for a private ISDN)? |                             |                                |
| 2.5         | fallback to 3,1 kHz teleservice inside itself (N/A for non private ISDN) on receipt of a 7 kHz fallback allowed SETUP message?  |                             |                                |
| 2.6         | fallback to 3,1 kHz teleservice inside itself (N/A for non private ISDN) on receipt of a videotelephony fallback allowed SETUP message?   |                             |                                |
| 2.7         | fallback to 7 kHz teleservice inside itself (N/A for non private ISDN) on receipt of a videotelephony fallback allowed SETUP message?   |                             |                                |

**B.6.4 Test management timers**

**Table B.3: Timer values**

| <b>Item</b> | <b>Timer values:<br/>Give a value for the timer that is used to ...</b>                             | <b>Value<br/>(in seconds)</b> |
|-------------|---|-------------------------------|
| 3.1         | control test events initiated by the test operator  |                               |
| 3.2         | control test events initiated by stimuli sent by the tester   |                               |
| 3.3         | control the inactivity of the IUT   |                               |
| 3.4         | wait for RESTART messages after establishment of the multiple frame operation (if 1.3 is supported) |                               |

**B.6.5 Parameter values**

**Table B.4: Parameter values**

| Item | Parameter values:<br>Give a ...  | Allowed values         | Value |
|------|--|------------------------|-------|
| 4.1  | value for the supported length of the call reference value   | BA: 1<br>PRA: 2        |       |
| 4.2  | coding of a Called party number information element, which the IUT is compatible with  | N/A                    |       |
| 4.3  | value for the preferred channel number (used in Channel identification information element) to be used for incoming calls  | BA: 1..2<br>PRA: 1..30 |       |
| 4.4  | value for the preferred channel number (used in Channel identification information element) to be used for a second incoming call on the same CES when two B-channel call is supported | BA: 1..2<br>PRA: 1..30 |       |

## **Annex C (normative):      Abstract Test Suite (ATS)**

This ATS has been produced using the Tree and Tabular Combined Notation (TTCN) according to ISO/IEC 9646-3 [14].

The ATS was developed on a separate TTCN software tool and therefore the TTCN tables are not completely referenced in the contents table. The ATS itself contains a test suite overview part which provides additional information and references (see also annex D).

### **C.1    The TTCN Graphical form (TTCN.GR)**

The TTCN.GR representation of this ATS is contained in a Postscript file (UT7v06.PS<sup>1)</sup>) which accompanies this ETS.

### **C.2    The TTCN Machine Processable form (TTCN.MP)**

The TTCN.MP representation corresponding to this ATS is contained in an ASCII file (UT7v06.MP<sup>1)</sup>) which accompanies this ETS.

NOTE:      According to ISO/IEC 9646-3 [14], in case of a conflict in interpretation of the operational semantics of TTCN.GR and TTCN.MP, the operational semantics of the TTCN.GR representation takes precedence.

---

<sup>1)</sup> This file is located in an archive file named 2674\_EP.LZH. Other file formats are available on request.

## **Annex D (informative): General structure of ATS**

This annex gives a simple listing of the order of types of tables which appear in a typical supplementary service ATS. This is intended as an aid in helping readers find particular sections quickly.

### **Test Suite Overview**

Test Suite Structure

Test Case Index

Test Step Index

Default Index

### **Declarations Part**

Simple Type Definitions

Structured Type Definitions

ASN.1 Type Definitions

Test Suite Operation Definitions

Test Suite Parameter Declarations

Test Case Selection Expression Definitions

Test Suite Constant Declarations

Test Case Variable Declarations

PCO Declarations

Co-ordination Point Declarations

Timer Declarations

Test Component Declarations

Test Components Configuration Declarations

TTCN ASP Type Definition

TTCN PDU Type Definition

TTCN CM Type Definition

Alias Definitions

### **Constraints Part**

Structured Type Constraint Declarations

ASN.1 Type Constraint Declarations

TTCN ASP Constraint Declarations

TTCN PDU Constraint Declarations

TTCN CM Constraint Declarations

### **Dynamic Part**

Test Case Dynamic Behaviour

Test Step Dynamic Behaviour

Default Dynamic Behaviour

## History

| Document history |  |
|------------------|--|
| April 1997       | Public Enquiry PE 9731: 1997-04-04 to 1997-08-01 |
|                  |  |
|                  |  |
|                  |  |
|                  |  |