



EUROPEAN
TELECOMMUNICATION
STANDARD

ETS 300 253

January 1995

Source: ETSI TC-EE

Reference: DE/EE-02002

ICS: 33.080

Key words: Equipment, earthing, bonding

**Equipment Engineering (EE);
Earthing and bonding of telecommunication equipment
in telecommunication centres**

ETSI

European Telecommunications Standards Institute

ETSI Secretariat

Postal address: F-06921 Sophia Antipolis CEDEX - FRANCE

Office address: 650 Route des Lucioles - Sophia Antipolis - Valbonne - FRANCE

X.400: c=fr, a=atlas, p=etsi, s=secretariat - **Internet:** secretariat@etsi.fr

Tel.: +33 92 94 42 00 - Fax: +33 93 65 47 16

Copyright Notification: No part may be reproduced except as authorized by written permission. The copyright and the foregoing restriction extend to reproduction in all media.

© European Telecommunications Standards Institute 1995. All rights reserved.

Contents

Foreword5

Introduction5

1 Scope7

2 Normative references7

3 Abbreviations and definitions8

 3.1 Abbreviations8

 3.2 Definitions8

 3.2.1 IEC definitions (by IEC 50 numbers)8

 3.2.2 Telecommunication definitions9

4 General requirements 10

 4.1 Safety from electrical hazards10

 4.2 Signal reference10

 4.3 EMC performance 10

5 Requirements on bonding networks 10

 5.1 Bonding configurations 10

 5.2 CBN within a telecommunication building 11

 5.3 BN within a telecommunication system 11

 5.4 Merging of CBN and MESH-BNs 14

 5.5 Cabling within and between BNs 14

6 Requirements for power distribution 14

 6.1 DC power distribution of secondary supply 14

 6.2 DC power distribution of tertiary supplies 14

 6.3 AC mains distribution and bonding of the protective conductor 15

 6.4 AC power distribution from tertiary power supply 15

Annex A (normative): Rationale about CBN co-ordination 18

Annex B (informative): Rationale about the integration of the DC return conductor into the merged CBN/MESH-BN 20

Annex C (informative): Bibliography 21

History 22

Blank page

Foreword

This European Telecommunication Standard (ETS) has been produced by the Equipment Engineering (EE) Technical Committee of the European Telecommunications Standards Institute (ETSI).

This ETS has been produced within the framework of the following considerations:

- a) centralized telecommunication equipment is generally installed in telecommunication centres and held in racks, cabinets or other mechanical structures;
- b) the existing CCITT and CCIR Recommendations and CENELEC standards in such matters do not ensure the required standardization at the equipment level;
- c) network operators and equipment providers agreed to standardize on a bonding configuration that facilitates:
 - compliance with functional requirements including Electromagnetic Compatibility (EMC) aspects of emission and immunity;
 - compatible building and equipment provisions;
 - installation of new telecommunication centres as well as expansion or replacement of installations in existing telecommunication centres with equipment coming from different suppliers;
 - a structured installation practice;
 - simple maintenance rules;
 - contracting on a common basis;
 - cost effectiveness in development, manufacturing, installation and operation.

Transposition dates	
Date of latest announcement of this ETS (doa):	30 April 1995
Date of latest publication of new National Standard or endorsement of this ETS (dop/e):	31 October 1995
Date of withdrawal of any conflicting National Standard (dow):	31 October 1995

Introduction

This ETS addresses earthing and bonding of telecommunication equipment in telecommunication centres in relation to safety, functional performance and EMC.

Information regarding the general principles on earthing for telecommunication sites has been published by the CCITT in the handbook on "Earthing of telecommunication installations" (see annex C). CCITT Recommendation K.27 deals with bonding configurations and earthing inside a telecommunication building. One bonding configuration only is selected from CCITT Recommendation K.27 and tailored to this ETS.

Blank page

1 Scope

This European Telecommunication Standard (ETS) applies in telecommunication centres and similar installations to the bonding network of the building, the bonding network of the equipment, and the interconnection between these two networks. It contributes to the standardization of telecommunication equipment and co-ordinates with the pre-requirements of installation conditions to achieve the following targets:

- safety from electrical hazards;
- reliable signal reference;
- satisfactory Electromagnetic Compatibility (EMC) performance.

A defined bonding configuration down to the equipment level shall facilitate the installation, operation and maintenance of telecommunication centres in telecommunication buildings or similar installations independent of the equipment supplier.

The specification of telecommunication equipment and of the pre-requirements of installation are subject to agreement of the parties (e.g. the supplier and the purchaser). Annex A can be used in the procedure to achieve agreement.

This ETS does not apply to telecommunication equipment not intended to be installed inside telecommunication centres, e.g.:

- smaller telecommunication equipment inside a subscriber's building;
- subscriber line terminal equipment.

NOTE: A separate ETS about earthing and bonding of telecommunication equipment inside a subscriber's building is under consideration.

2 Normative references

This ETS incorporates by dated and undated reference, provisions from other publications. These normative references are cited at the appropriate places in the text and the publications are listed hereafter. For dated references, subsequent amendments to or revisions of any of these publications apply to this ETS only when incorporated in it by amendment or revision. For undated references the latest edition of the publication referred to applies.

- | | |
|-----|---|
| [1] | CENELEC HD 384.4.41: "Electrical installation of buildings; Part 4: Protection for safety; Chapter 41: Protection against electric shock". |
| [2] | CENELEC HD 384.5.54: "Electrical installation of buildings; Part 5: Selection and erection of electrical equipment; Chapter 54: Earthing arrangements and protective conductors". |
| [3] | CENELEC EN 60950: "Safety of information technology equipment including electrical business equipment" (as correspondent to IEC 950). |
| [4] | CENELEC EN 41003: "Particular safety requirements for equipment to be connected to telecommunication networks". |
| [5] | IEC 50: "International Electrotechnical Vocabulary". |
| [6] | IEC 50 (604): "International Electrotechnical Vocabulary; Chapter 604: Generation, transmission and distribution of electricity - Operation". |
| [7] | IEC 50 (826): "International Electrotechnical Vocabulary; Chapter 826: Electrical installations of buildings". |

3 Abbreviations and definitions

3.1 Abbreviations

For the purposes of this ETS, the following abbreviations apply:

AC	Alternating Current
BN	Bonding Network
CBN	Common Bonding Network
DC	Direct Current
EMC	Electromagnetic Compatibility
LPS	Lightning Protection System
MESH-BN	Meshed Bonding Network
MESH-IBN	Meshed Isolated Bonding Network
N	Neutral conductor
PE	Protective conductor
PEN	combined Protective conductor and Neutral conductor
RF	Radio Frequency
SRPP	System Reference Potential Plane

3.2 Definitions

The following definitions with respect to earthing and bonding are introduced by the IEC 50 [5] and are used within this ETS to maintain conformity.

3.2.1 IEC definitions (by IEC 50 numbers)

NOTE: IEC 50 [5] references are given in parentheses (see IEC 50 (604) [6] and IEC 50 (826) [7]).

earth (826-04-01): The conductive mass of earth, whose electric potential at any point is conventionally taken as equal to zero.

earth electrode (826-04-02): A conductive part or a group of conductive parts in intimate contact with and providing an electrical connection with earth.

earthing network (604-04-07): The part of an earthing installation that is restricted to the earth electrodes and their interconnections.

earthing conductor (826-04-07): A protective conductor connecting the main earthing terminal or bar to the earth electrode.

main earthing terminal (826-04-08): A terminal or bar provided for the connection of protective conductors, including equipotential bonding conductors and conductors for functional earthing if any, to the means of earthing.

equipotential bonding (826-04-09): Electrical connection putting various exposed conductive parts and extraneous conductive parts at a substantially equal potential.

equipotential bonding conductor (826-04-10): A protective conductor for ensuring equipotential bonding.

Protective conductor (PE) (826-04-05): A conductor required by some measures for protection against electric shock by electrically connecting any of the following parts:

- exposed conductive parts;
- extraneous conductive parts;
- main earthing terminal;
- earth electrode;

- earthed point of the source or artificial neutral.

Neutral conductor (N) (826-01-03): A conductor connected to the neutral point of a system and capable of contributing to the transmission of electrical energy.

PEN conductor (826-04-06): An earthed conductor combining the functions of both protective conductor and neutral conductor.

IT: See IEC Standard 364-3.

TN-C: See IEC Standard 364-3.

TN-S: See IEC Standard 364-3.

TT: See IEC Standard 364-3.

3.2.2 Telecommunication definitions

The following definitions, specific to telecommunication installations and not covered by the IEC 50 [5], are used within this ETS. Correspondence to CCITT Recommendation K.27 (see annex C) is indicated as appropriate.

Bonding Network (BN), (CCITT Recommendation K.27): A set of interconnected conductive structures that provides an "electromagnetic shield" for electronic systems and personnel at frequencies from Direct Current (DC) to low Radio Frequency (RF). The term "electromagnetic shield" denotes any structure used to divert, block or impede the passage of electromagnetic energy. In general, a BN need not be connected to earth but all BNs considered in this ETS will have an earth connection.

Common Bonding Network (CBN), (CCITT Recommendation K.27): The CBN is the principal means for effective bonding and earthing inside a telecommunication building. It is the set of metallic components that are intentionally or incidentally interconnected to form the principal BN in a building. These components include: structural steel or reinforcing rods, metallic plumbing, Alternating Current (AC) power conduit, PE conductors, cable racks and bonding conductors. The CBN always has a mesh topology and is connected to the earthing network.

Meshed Bonding Network (MESH-BN), (CCITT Recommendation K.27): A bonding network in which all associated equipment frames, racks and cabinets and usually the DC power return conductor, are bonded together as well as at multiple points to the CBN. Consequently, the MESH-BN augments the CBN (see figure 1).

Meshed Isolated Bonding Network (MESH-IBN), (CCITT Recommendation K.27): A type of IBN in which the components of the IBN (e.g. equipment frames) are interconnected to form a mesh-like structure. This may, for example, be achieved by multiple interconnections between cabinet rows, or by connecting all equipment frames to a metallic grid (a "bonding mat") extending beneath the equipment. The bonding mat is, of course, insulated from the adjacent CBN. If necessary the bonding mat could include vertical extensions, resulting in an approximation to a Faraday cage. The spacing of the grid is chosen according to the frequency range of the electromagnetic environment.

system: A regularly interacting or interdependent group of items forming a unified whole.

system block: A functional group of equipment depending in its operation and performance on its connection to the same system reference potential plane, inherent to a MESH-BN.

System Reference Potential Plane (SRPP): A conductive solid plane, as an ideal goal in potential equalising, is approached in practice by horizontal or vertical meshes. The mesh width thereof is adapted to the frequency range to be considered. Horizontal and vertical meshes may be interconnected to form a grid structure approximating to a Faraday cage.

The SRPP facilitates signalling with reference to a common potential.

bonding mat: Essential means to provide a SRPP by a discernible, nearly regular mesh structure. The bonding mat may be located either below or above a collection of equipment constituting a system block.

power supply:

- **primary supply:** The public mains or, under emergency conditions, a locally generated AC supply;
- **secondary supply:** The supply to the telecommunication equipment, racks or system block, derived from the primary supply;
- **tertiary supplies:** The supplies to the telecommunication equipment, derived from the secondary supply.

DC return conductor: The (+) conductor of the -48 V or -60 V secondary DC supply.

4 General requirements

4.1 Safety from electrical hazards

To achieve safety it is required to design equipment to the standards EN 60950 [3], EN 41003 [4] and CENELEC HD 384.4.41 [1] and to perform the installation of PEs and equipotential bonding conductors, according to CENELEC HD 384.5.54 [2].

The conductors involved shall provide sufficiently high current conducting capability and low impedance according to the relevant safety standards to avoid electric shock, risk of fire, or damage to the equipment under normal or faulty operating conditions within an equipment or the distribution network, or due to the impact of induced voltage and current, e.g. by lightning.

4.2 Signal reference

Reliable signal reference shall be provided by a SRPP dedicated at least to a functional unit or a system block. To avoid undue functional distortion or risk of component failure, the SRPP shall provide sufficiently low impedance up to the highest frequency to be regarded by using a metal plane or a meshed configuration having adequate mesh dimensions, e.g. a bonding mat. The frequency band to be covered shall include the spectral components of transients caused by switching, short circuits and atmospheric discharges.

NOTE: Signal reference to the SRPP does not always imply signal return via the SRPP.

4.3 EMC performance

Measures to gain a satisfactory EMC performance shall be assisted by a SRPP. The SRPP shall provide sufficiently low impedance for efficient connection of filters, cabinets and cable shields. The requirement to avoid undue emission of, or susceptibility to electromagnetic energy under normal operating conditions may govern the properties of the SRPP ahead of what is required in subclause 4.2. The EMC requirements addressed include the discharge of electrostatic energy.

5 Requirements on bonding networks

5.1 Bonding configurations

Bonding configurations can be addressed at a building level (i.e. CBN), at an installation level (i.e. merging of CBN and Meshed Bonding Network (MESH-BN)) and at an equipment level (i.e. MESH-BN).

CCITT Recommendation K.27 deals with bonding configurations of telecommunication equipment at a building and installation level. Regarding the bonding configuration at an equipment level a MESH-BN is explicitly distinguished in this ETS.

5.2 CBN within a telecommunication building

Each telecommunication building shall be provided with a CBN having sufficiently low impedance and high current conducting capability to meet the general requirements of clause 4. Equipotential bonding conductors shall be used (see IEC publication 364-5-54, section 547.1.2).

The earthing conductor and the equipotential bonding conductors should be coloured in accordance to international and national regulations.

The main earthing terminal of the CBN shall be extended by a bonding ring conductor along the inside perimeter of the building, or a ring conductor, as a basic element of the CBN, shall at least comprise a system block by its outer perimeter. A growth by extension of the telecommunication installation inside a building requires such a minimum CBN version to be augmented into a three dimensional grid structure, approximating a Faraday cage (see figure 1). The impact of interfering energy in an exposed location or the need for information security enforces the provision of shielded rooms as a maximum requirement to the CBN.

Annex A gives information about the implementation principles for the CBN, thereby following CCITT Recommendation K.27, § 4.2.1.

5.3 BN within a telecommunication system

Within a telecommunication system, especially a system block, the BN shall be of the mesh type. The MESH-BN shall provide sufficiently low impedance and high current conducting capability to meet the general requirements in clause 4.

The MESH-BN shall interconnect shelves, cabinets, rack rows, cable racks, ducts, troughs, distribution frames, cable shields and bonding mat to constitute the required SRPP.

All metallic parts of the MESH-BN shall form an electrically continuous whole. This does not necessarily require bonding by additional bonding straps, but that improvements should be taken into account when determining the finishes and fastening methods to be used. The mechanical structure comprised by the MESH-BN shall form part of the SRPP.

As an example, figure 2 addresses interconnections within a system block, essential to a MESH-BN. This example follows the implementation principles for the MESH-BN outlined in CCITT Recommendation K.27 § 4.2.2.

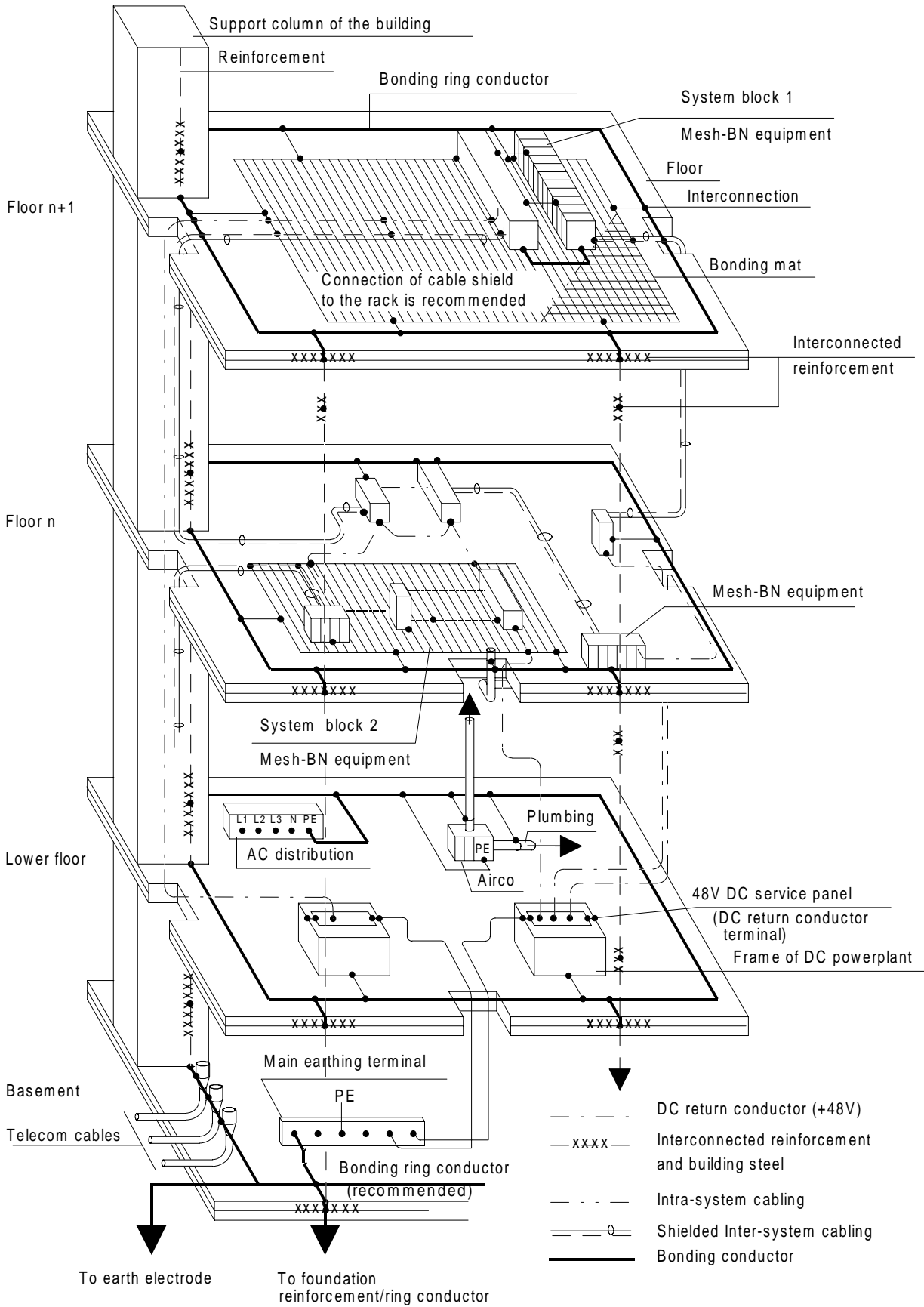

Figure 1: CBN/MESH-BN installation inside a telecommunication building

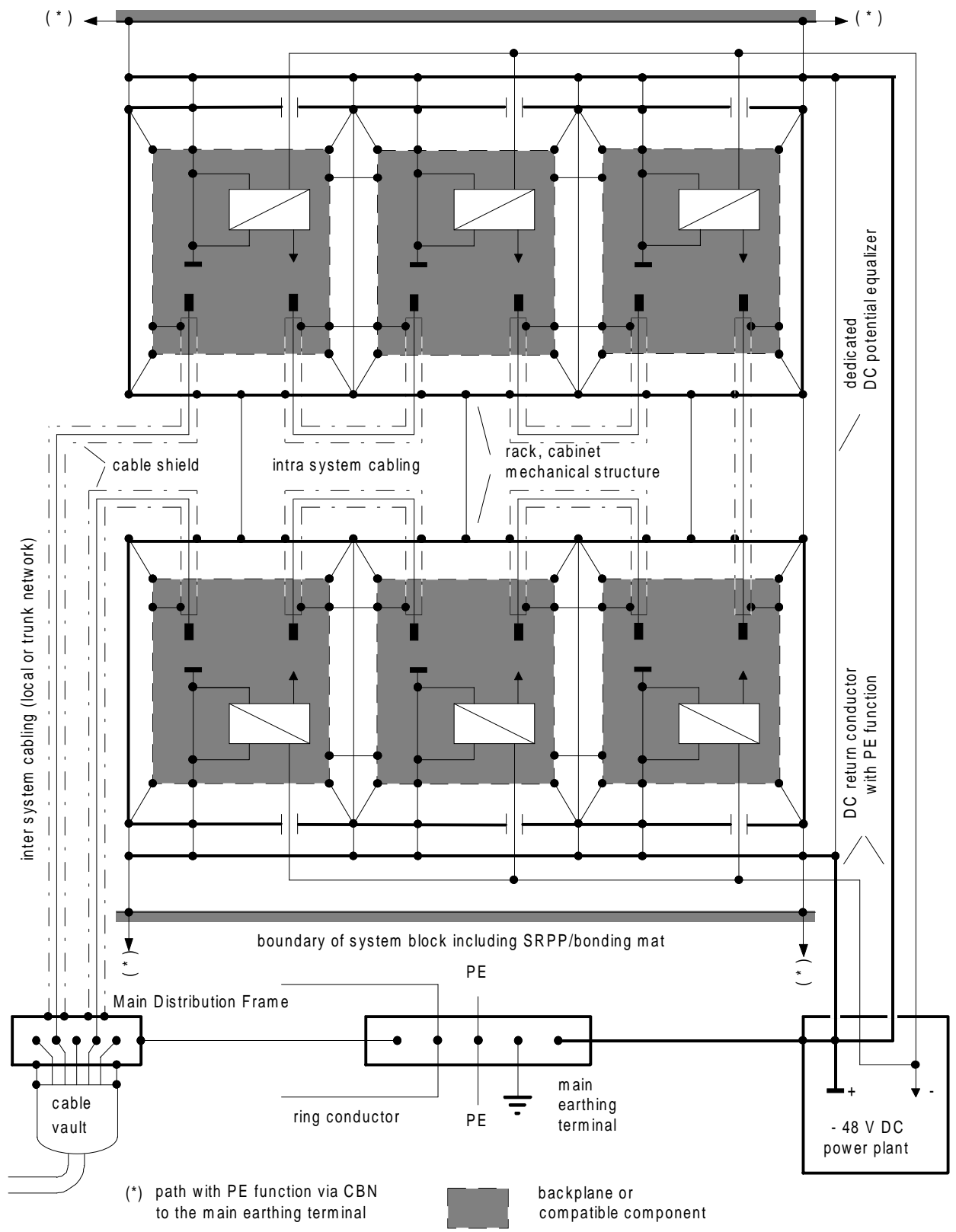

Figure 2: Example of a system block installation with an overall CBN/MESH-BN configuration

5.4 Merging of CBN and MESH-BNs

All BNs of telecommunication systems and their associated DC return conductors shall be connected to the CBN.

The MESH-BN shall augment the CBN including the main earthing terminal by multiple interconnections to the CBN (see figures 1 and 2).

5.5 Cabling within and between BNs

Power distribution cables and signal cables within and between MESH-BNs shall be run tightly along the members of the augmented CBN.

There shall be a separation distance of at least 100 mm between cable tracks of AC mains cables and signal cables, unless adequate shielding is provided.

Cable shields shall be bonded directly to racks, cabinets or to the dedicated SRPP at least at each end. Circumferential connections are most effective and therefore are recommended.

NOTE: It is recognized that where a new system has to be cabled to existing equipment, it has previously been considered feasible to avoid the connection of cable shields at the existing equipment end. However, the consequent solution of this ETS is to provide a lower impedance path via improved bonding between the equipment locations, thereby enabling connection of cable shields at least at each end.

6 Requirements for power distribution

6.1 DC power distribution of secondary supply

The DC power distribution shall use (+) and (-) conductors routed close together. Each DC return conductor serving a telecommunication system shall be bonded to the CBN at least at the main earthing terminal, at the service panel of the DC power plant and to the MESH-BN to at least one point of the SRPP.

The maximum DC voltage drop along each dedicated DC power return conductor shall be designed to be less than 1 V. The calculation shall take into account the maximum load current on the associated supply conductor at maximum or minimum source voltage respectively under normal operating conditions.

NOTE: One concern of this requirement is to avoid electrochemical corrosion by stray currents.

The DC return path in its entire length shall be capable of carrying over-currents in the case of a fault between a negative power conductor of the secondary supply and the MESH-BN.

The DC return terminal of a power plant powering the telecommunication system(s) shall be earthed at its DC service panel by a solid connection to the main earthing terminal.

Annex B gives information about necessary agreements if, under exceptional conditions, DC return conductors of a single equipment group cannot be integrated into the merged CBN/MESH-BN.

6.2 DC power distribution of tertiary supplies

The reference potential terminal of tertiary power supplies shall be connected to the MESH-BN.

6.3 AC mains distribution and bonding of the protective conductor

The definitions used in this subclause are based on IEC 364-3.

The AC power distribution inside a telecommunication building shall conform to the requirements of the TN-S system. This requires that there shall be no PEN conductor within the building, i.e. the option in IEC 364, section 546.2.1, shall not be used. This is a pre-condition to the requirements in clause 5 of this ETS.

Depending on the outdoor mains distribution network serving a telecommunication building, one of the following requirements shall apply:

- a) service by a TN-S section of the outdoor distribution network:

solely the protective conductor (PE) shall be connected to the main earthing terminal (see figure 3, structure 1 and figure 4, mode 1);
- b) service by a TN-C section of the outdoor distribution network:
 - 1) the PEN conductor shall be connected to the main earthing terminal only;
 - 2) from the main earthing terminal to and within the consumer locations inside the building the Neutral conductor (N) shall be treated as a live conductor;
 - 3) a dedicated PE shall be provided (see figure 3, structure 2 and figure 4, mode 2).
- c) service by a TT section of the outdoor distribution network:
 - 1) the PE shall be derived via the main earthing terminal from the earthing network (see figure 3, structure 3 and figure 4, mode 3);
 - 2) the dimensioning of the PE shall follow the rules of the TN-S system.
- d) service by an IT section of the outdoor distribution network:

indoor installation related to earthing and bonding shall follow the instructions set up for the service by a TT section of the outdoor distribution network.

NOTE: Public service by an IT section of the outdoor distribution network is known as a special national condition. As the IT system is liable to deteriorate into a TT system, reference is given in this ETS to that related section. For information regarding unacceptable interference by an IT system, see annex A.

6.4 AC power distribution from tertiary power supply

The neutral point of a tertiary AC power supply shall be derived by bonding the terminal of the star point, or of an outer conductor respectively, to the MESH-BN at the source only. The distribution to the assigned loads shall follow the rules of the TN-S system.

If different configurations resembling an IT system have to be used (e.g. to provide remote feeding or the uninterruptible power supply of a subarrangement), the appropriate safety precautions shall be implemented without degrading the effectiveness of the general requirements in clause 4.

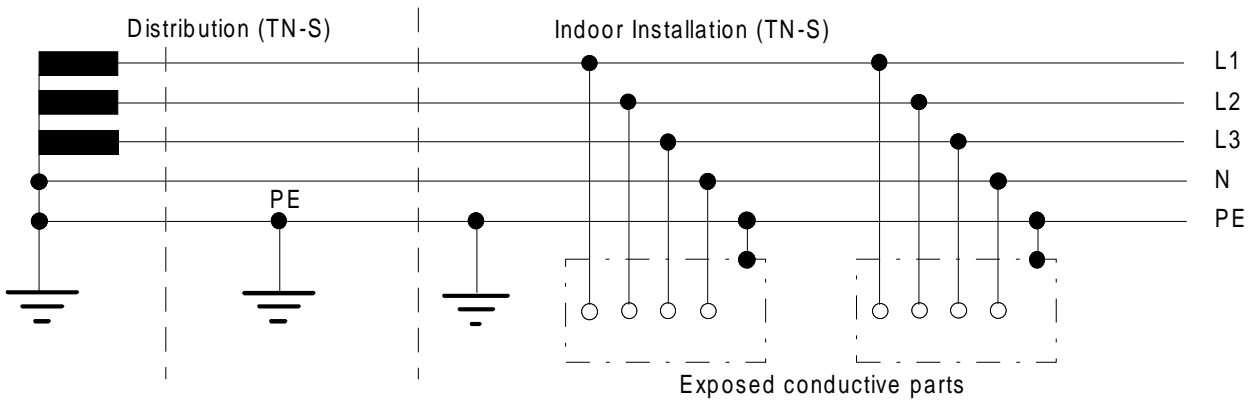

- origin of PE at the main earthing terminal of the power source;
- PE is intentionally earthed intermediately in the distribution and at each main earthing terminal;
- N and PE are separated throughout the distribution, the indoor installation and within each equipment.

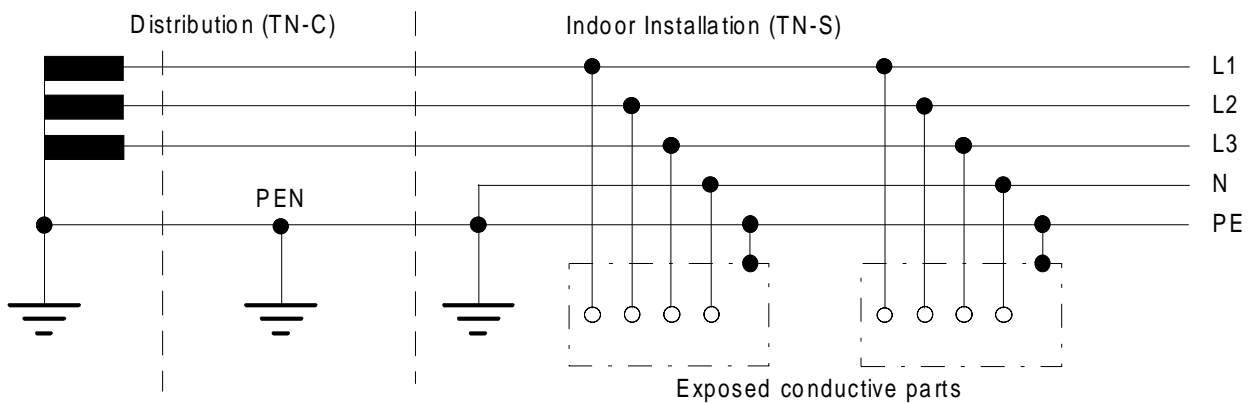

- origin of PEN at the main earthing terminal of the power source;
- PEN is intentionally earthed intermediately in the distribution and at each main earthing terminal;
- origin of N and PE at the main earthing terminal of the indoor installation;
- N and PE are separated throughout the indoor installation and within each equipment.

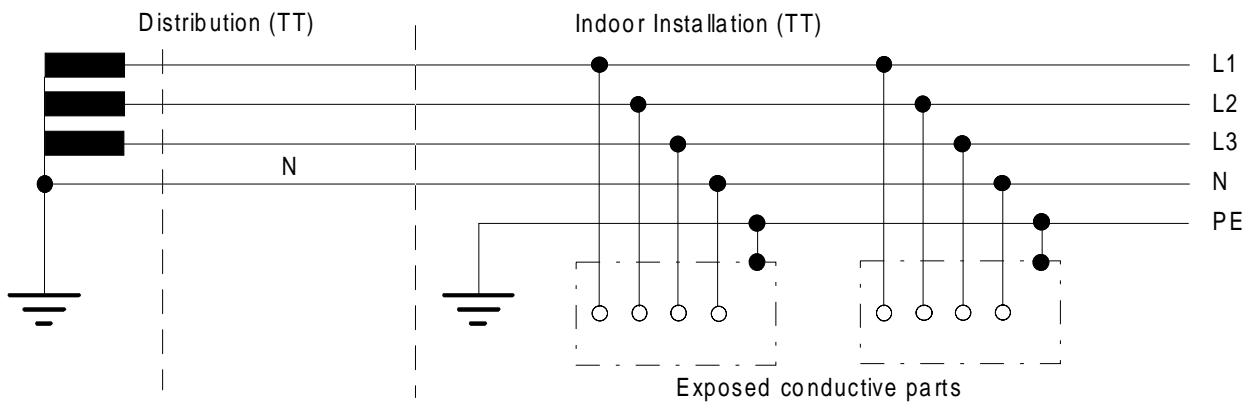

- origin of PE at the local main earthing terminal of the indoor installation;
- N and PE are separated throughout the indoor installation and within each equipment.

Figure 3: Conventional mains supply systems (based on IEC Publication 364, section 312.2)

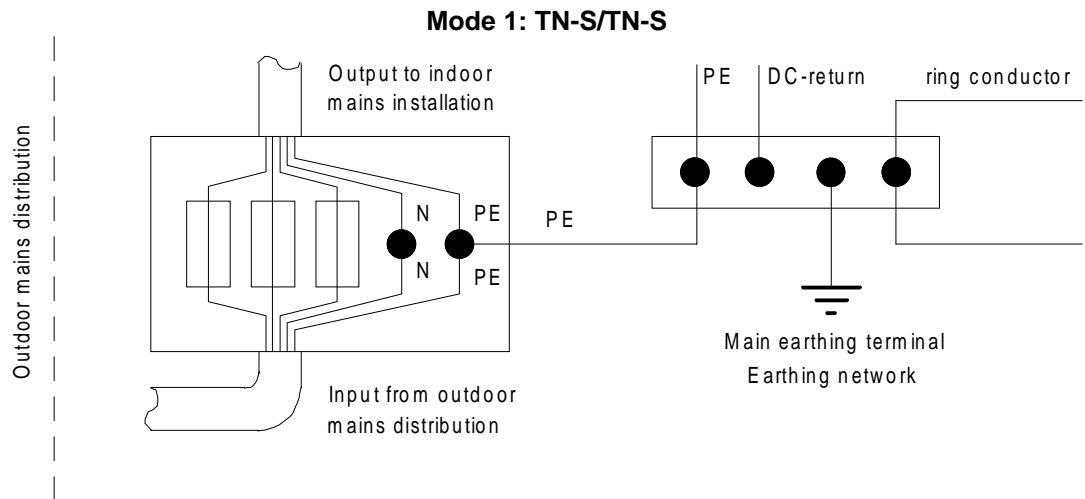

NOTE: Mode 1 is obligatory if a separation transformer is dedicated to the building and the TN-S System consequently originates at the transformer load side.

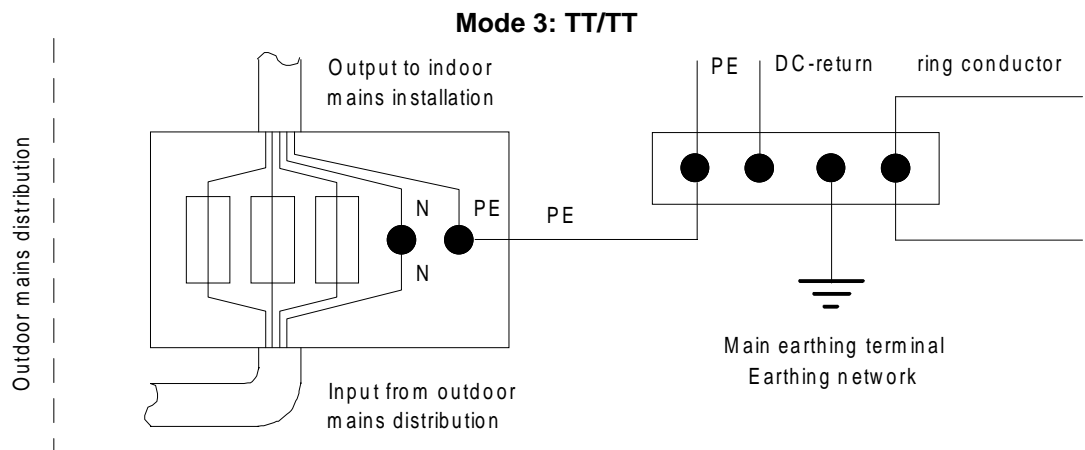
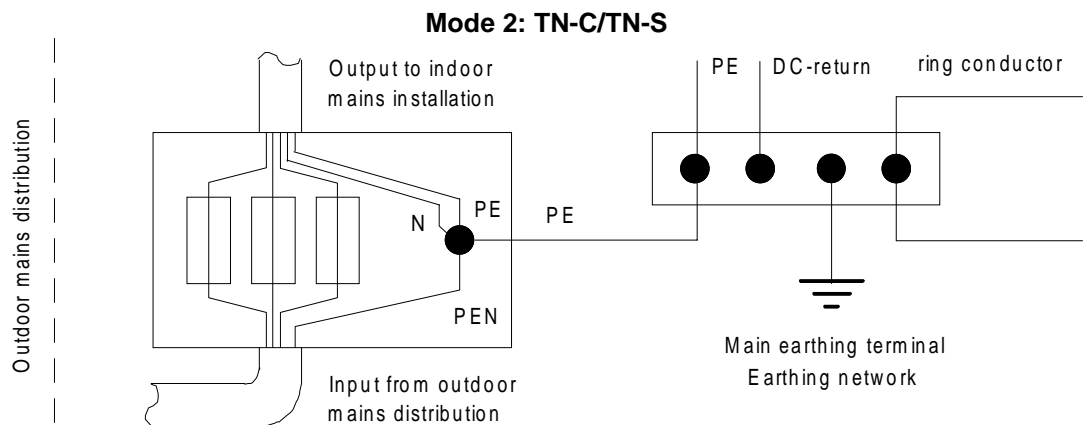

Figure 4: Arrangements for the transition from the outdoor mains distribution network to the indoor mains installation

Annex A (normative): Rationale about CBN co-ordination

In the case of a telecommunication centre there are two main subjects needing co-ordination with respect to EMC:

- the building and its related ordinary installations;
- the telecommunication equipment and its interconnection.

New buildings shall provide adequate preconditions constituting a CBN by:

- a reliable foundation earth electrode system, i.e. a ring conductor immediately beneath the first concrete bed (see references [A.1] and [A.2]);

NOTE: This electrode system qualifies prior to a ring conductor along the outer perimeter of a building.

- welded joints of building steel or concrete reinforcement rods (see DIN 4099 [A.3] and IEC 1024-1 [A.4]) and a sufficient number of access terminals to these highly conductive elements;
- an enhanced outdoor Lightning Protection System (LPS) co-ordinated with the building structure (see IEC 1024-1 [A.4]);
- service pipes and air-conditioning ducts interconnected according to the CBN strategy, including potential equalization in excess of safety regulations;
- mains power supply installation as required for the TN-S principle, i.e. without any PEN section downstream from the main earthing terminal and regardless of the principle applied to the mains distribution section upstream. The option in IEC 364 section 546.2.1 permitting for a PEN conductor with a minimum cross sectional area shall not be used.

Telecommunication equipment which is designed to this ETS can be installed and interconnected to the CBN outlined above. The resulting MESH-BN (e.g. see figure 1) should easily conform to EMC requirements.

Some existing buildings of telecommunication centres do not provide a CBN sufficient to meet the operational requirements. When a decision is made to extend or replace existing telecommunication installations in such buildings, the objective should be to move towards a CBN by enhancements.

Besides the fact that such enhancements require consultation on the spot, two subjects can be addressed in general:

- outdoor lightning protection may be installed at first according to IEC 1024 [A.4] including a ring conductor as an essential member of the earthing network. The LPS may be improved with conductive roof layers, closely spaced down conductors or application of metallic facades;
- unacceptable interference from the outdoor power distribution section can be mitigated by a separation transformer dedicated to the building or by an equivalent measure. An indoor installation according to the rules of the IT system or TT system can be upgraded by additional PE conductors and dedicated equipotential bonding conductors, thereby reducing the mesh width. A residual current protection may also be adapted if necessary.

An existing CBN can be augmented by the telecommunication installation regarding dedicated ring conductors per room and floor, cable ducts/troughs/racks and any other supporting metal work. In contrast to the traditional practice to indulge into a restricted number of conductors with enlarged cross sectional area, it is recommended to aim at a large conductive surface, e.g. by providing bonding at both side bars, at joints within the run of a ladder type cable rack.

As outlined above, co-ordination resulting in an overall CBN/MESH-BN is recommended even in existing telecommunication centres. Installation of new equipment with deviation into the Meshed Isolated Bonding Network (MESH-IBN), as defined in CCITT Recommendation K.27 and depicted in figure B-2 of CCITT Recommendation K.27, is considered appropriate in exceptional situations only, such as a deficiency of an

adequate lightning protection of the building, or a CBN with an interfering PEN section, or incompatibility with already installed telecommunication equipment.

Nevertheless, a MESH-IBN type installation according to CCITT Recommendation K.27 needs co-ordination concerning the routing of cables and the bonding of their shields. In addition, maintenance procedures have to be extended to isolation inspection or monitoring.

References:

- [A.1] Vereinigung Deutscher Elektrizitätswerke - VDEW - e.V. Richtlinien für das Einbetten von Fundamenterdern in Gebäudefundamenten. Ausgabe 1987 Verlags und Wirtschaftsgesellschaft der Elektrizitätswerke m.b.H - VDEW Stresemannallee 23, D6000 Frankfurt/Main 70 ISBN 3-8022-0076-4.

- [A.2] F. Wyss: Fundamenterder und Armierungen als Erder (SEV 3569-1, SEV 3569-2, SEV 3569-3) Referat 4 der ETG - Informationstagungen Erdungen, Januar 1987 in der Reihe ETG: Band 1d Schweizerischer Elektrotechnischer Verein, Vereinsverwaltung Postfach, CH 8034 Zürich.

- [A.3] DIN 4099, November 1985 Schweißen von Betonstahl, Ausführung und Prüfung. Welding of reinforcing steel, procedure and test. Beuth Verlag GmbH, Burggrafstraße 4-10, D1000 Berlin 30.

- [A.4] IEC 1024-1, March 1990 Protection of structures against lightning. Part 1: General principles.

Annex B (informative): Rationale about the integration of the DC return conductor into the merged CBN/MESH-BN

The integration of the DC return conductor is addressed in subclauses 5.4 and 6.1. When existing equipment requires replacement, it is essential that equipment design and installation conforms to a single standard without ambiguity. Agreement to this aim is stated in the Foreword of this ETS.

It is recognized that in existing installations groups of equipment may be operated with "isolated" DC return conductors, whereby "isolated" denotes the application of the DC-I version addressed in CCITT Recommendation K.27.

If the design of such equipment allows for operation with integrated DC return conductors, the existing installation should be adapted to this ETS.

If the operation of such equipment requires the existing installation to be unchanged, precautions have to be taken to facilitate appropriate inter system signal exchange and compliance to other EMC requirements.

Selection of such precautions shall take into account:

- inter system signal exchange by isolated and symmetrically operated circuitry;
- routing of cables with shields via a common bonding point, located as near as possible to the main earthing terminal, e.g. the main distribution frame, if transmission parameters allow for an additional length of the transmission path;
- appropriate conductor arrangements in parallel to the inter system cabling route with minimized length dictated by transmission requirements, i.e. provision of shielding and potential equalization simultaneously;
- upgrading of the current conducting capability of the drain path for short circuit currents, i.e. provision of dedicated conductors without the steady state DC return function.

If the outlined adaptation of the existing installation is impossible due to an additional insufficiency of the CBN, installation of a new system block may follow the rules of the MESH-IBN (see annex A).

Annex C (informative): Bibliography

The following references are used for information purposes within this ETS.

- 1) CCITT handbook: "Earthing of telecommunication installations" (Geneva 1976).
- 2) CCITT Recommendation K.27 (1991): "Bonding Configurations and Earthing inside a Telecommunication Building".
- 3) ETS 300 132-1: "Equipment Engineering (EE); Power supply interface at the input to telecommunications equipment interface; Part 1: Interface operated by Alternating Current (AC)".
- 4) ETS 300 132-2: "Equipment Engineering (EE); Power supply interface at the input to telecommunications equipment interface; Part 2: Interface operated by Direct Current (DC)".
- 5) IEC Standard 364: "Electrical installation of buildings".
- 6) IEC Standard 364-1 (1972): "Electrical installation of buildings; Part 1: Scope, object and definitions".
- 7) IEC Standard 364-3: "Electrical installation of buildings; Part 3: Assessment of general characteristics".
- 8) IEC Standard 364-4-41 (1982): "Electrical installation of buildings; Part 4: Protection and safety. Chapter 41: Protection against electric shock".
- 9) IEC Standard 364-5-54 (1980): "Electrical installation of buildings; (Amendment of 1982) Part 5: Selection and erection of electrical equipment. Chapter 54: Earthing arrangements and protective conductors".
- 10) IEC Standard 950 (1986): "Safety of information technology equipment, (Amendment of 1988) including Electrical business equipment".

History

Document history	
January 1995	First Edition
January 1996	Converted into Adobe Acrobat Portable Document Format (PDF)