



EUROPEAN
TELECOMMUNICATION
STANDARD

ETS 300 204

December 1994

Source: ETSI TC-SPS

Reference: T/S 22-06,1

ICS: 33.080

Key words: ISDN, supplementary service.

**Integrated Services Digital Network (ISDN);
Call Forwarding Unconditional (CFU) supplementary service
Functional capabilities and information flows**

ETSI

European Telecommunications Standards Institute

ETSI Secretariat

Postal address: F-06921 Sophia Antipolis CEDEX - FRANCE

Office address: 650 Route des Lucioles - Sophia Antipolis - Valbonne - FRANCE

X.400: c=fr, a=atlas, p=etsi, s=secretariat - **Internet:** secretariat@etsi.fr

Tel.: +33 92 94 42 00 - Fax: +33 93 65 47 16

Copyright Notification: No part may be reproduced except as authorized by written permission. The copyright and the foregoing restriction extend to reproduction in all media.

© European Telecommunications Standards Institute 1994. All rights reserved.

Contents

Foreword.....	5
1 Scope	7
2 Normative references	7
3 Definitions.....	8
4 Abbreviations	9
5 Description	9
6 Derivation of the functional model	9
6.1 Functional model description	9
6.2 Description of the FEs	10
6.3 Relationship with a basic service	10
7 Information flows.....	10
7.1 Information flow diagrams.....	10
7.2 Definition of individual information flows.....	13
7.2.1 Relationship ra	13
7.2.1.1 Contents of INFORM2	13
7.2.1.2 Contents of INFORM7	13
7.2.2 Relationship rb	13
7.2.2.1 Contents of INFORM1	13
7.2.2.2 Contents of INFORM6	14
7.2.3 Relationship rc	14
7.2.3.1 Contents of INFORM10 (rerouteing request).....	14
7.2.4 Relationship rd	15
7.2.4.1 Contents of INFORM3	15
7.2.5 Relationship re	15
7.2.5.1 Contents of INFORM4	15
7.2.5.2 Contents of INFORM6	16
7.2.6 Relationship rf	16
7.2.6.1 Contents of INFORM4	16
7.2.6.2 Contents of INFORM6	16
7.2.7 Relationship rg	17
7.2.7.1 Contents of INFORM5	17
8 SDL diagrams for FEs	17
8.1 FE1.....	18
8.2 FE2.....	19
8.3 FE3.....	23
8.4 FE4.....	27
8.5 FE5.....	31
8.6 FE6.....	32
8.7 FE7.....	36
8.8 FE8.....	39
9 Functional Entity Actions (FEAs).....	40
9.1 FEAs of FE1	40
9.2 FEAs of FE2.....	40
9.3 FEAs of FE3.....	40
9.4 FEAs of FE4.....	40

9.5	FEAs of FE5.....	41
9.6	FEAs of FE6.....	41
9.7	FEAs of FE7.....	41
9.8	FEAs of FE8.....	41
10	Allocation of FEs to physical locations.....	42
Annex A (informative):	Explanatory model for multiple diversion.....	43
Annex B (normative):	Activation, deactivation, registration and interrogation.....	44
B.1	Definitions.....	44
B.2	Description.....	44
B.3	Derivation of the functional model.....	45
B.3.1	Functional model description.....	45
B.3.2	Description of the FEs.....	45
B.3.3	Relationship with a basic service.....	46
B.3.4	Relationship of the user's Service Control Model (SCM) to the CFU supplementary service FE model.....	46
B.4	Information flows.....	47
B.4.1	Information flow diagram for the SSC.....	47
B.4.2	Definition of individual information flows.....	48
B.4.2.1	Relationship rx.....	48
B.4.2.1.1	Contents of ACTIVATION.....	48
B.4.2.1.2	Contents of DEACTIVATION.....	49
B.4.2.2	Relationship ry.....	49
B.4.2.2.1	Contents of INFORM1.....	49
B.4.2.2.2	Contents of INFORM2.....	50
B.4.2.2.3	Contents of INTERROGATION.....	50
B.4.2.2.4	Contents of NUMBER INTERROGATION.....	51
B.5	SDL diagrams for SCEs.....	51
B.5.1	SCE1.....	52
B.5.2	SCE2.....	53
B.5.3	SCE3.....	56
B.6	SCE actions.....	57
B.6.1	SCE1.....	57
B.6.2	SCE2.....	57
B.6.3	SCE3.....	57
B.7	Allocation of SCEs to physical locations.....	57
History	58

Foreword

This European Telecommunication Standard (ETS) has been produced by the Signalling Protocols and Switching (SPS) Technical Committee of the European Telecommunications Standards Institute (ETSI).

In accordance with CCITT Recommendation I.130, the following three level structure is used to describe the supplementary telecommunication services as provided by European public telecommunications operators under the pan-European Integrated Services Digital Network (ISDN):

- Stage 1: is an overall service description, from the user's standpoint;
- Stage 2: identifies the functional capabilities and information flows needed to support the service described in stage 1; and
- Stage 3: defines the signalling system protocols and switching functions needed to implement the service described in stage 1.

This ETS details the stage 2 aspects (functional capabilities and information flows) needed to support the Call Forwarding Unconditional (CFU) supplementary service. The stage 1 and stage 3 aspects are detailed in ETS 300 200 (1994) and ETS 300 207-1 (1994), respectively.

Proposed transposition dates	
Date of latest announcement of this ETS (doa):	31 March 1995
Date of latest publication of new National Standard or endorsement of this ETS (dop/e):	30 September 1995
Date of withdrawal of any conflicting National Standard (dow):	30 September 1995

Blank page

1 Scope

This European Telecommunication Standard (ETS) defines the stage two of the Call Forwarding Unconditional (CFU) supplementary service for the pan-European Integrated Services Digital Network (ISDN) as provided by European public telecommunications operators. Stage two identifies the functional capabilities and the information flows needed to support the stage one service description. The stage two description also identifies user operations not directly associated with a call (see CCITT Recommendation I.130 [3]).

This ETS is specified according to the methodology defined in CCITT Recommendation Q.65 [6].

This ETS does not formally describe the relationship between this supplementary service and the basic call, but where possible this information is included for guidance.

In addition this ETS does not specify the requirements where the service is provided to the user via a private ISDN. This ETS does not specify the requirements for the allocation of defined Functional Entities (FEs) within a private ISDN; it does, however, define which FEs may be allocated to a private ISDN.

This ETS does not specify the additional requirements where the service is provided to the user via a telecommunications network that is not an ISDN.

The CFU supplementary service enables a served user to have the network redirect to another user calls which are addressed to the served user's ISDN number. The CFU supplementary service may operate on all calls, or just those associated with specified basic services. The served user's ability to originate calls is unaffected by the CFU supplementary service. After the CFU supplementary service has been activated, calls are forwarded independent of the status of the served user.

The CFU supplementary service is applicable to all circuit-switched telecommunication services.

This ETS is applicable to the stage three standards for the ISDN CFU supplementary service. The term "stage three" is also defined in CCITT Recommendation I.130 [3]. Where the text indicates the status of a requirement, i.e. as strict command or prohibition, as authorization leaving freedom, as a capability or possibility, this shall be reflected in the text of the relevant stage three standards.

Furthermore, conformance to this ETS is met by conforming to the stage three standards with the field of application appropriate to the equipment being implemented. Therefore, no method of testing is provided for this ETS.

2 Normative references

This ETS incorporates by dated or undated reference, provisions from other publications. These normative references are cited at the appropriate places in the text and the publications are listed hereafter. For dated references, subsequent amendments to or revisions of any of these publications apply to this ETS only when incorporated in it by amendment or revision. For undated references the latest edition of the publication referred to applies.

- [1] CCITT Recommendation E.164 (1991): "Numbering plan for the ISDN era".
- [2] ITU-T Recommendation I.112 (1993): "Vocabulary of terms for ISDNs".
- [3] CCITT Recommendation I.130 (1988): "Method for the characterization of telecommunication services supported by an ISDN and network capabilities of an ISDN".
- [4] ITU-T Recommendation I.210 (1993): "Principles of telecommunication services supported by an ISDN and the means to describe them".

- [5] CCITT Recommendation Q.9 (1988): "Vocabulary of switching and signalling terms".
- [6] CCITT Recommendation Q.65 (1988): "Stage 2 of the method for the characterization of services supported by an ISDN".
- [7] CCITT Recommendation Q.71 (1988): "ISDN 64 kbit/s circuit mode switched bearer service".
- [8] CCITT Recommendation Z.100 (1988): "Specification and Description Language (SDL)".
- [9] ETS 300 200: "Integrated Services Digital Network (ISDN); Call Forwarding Unconditional (CFU) supplementary service; Service description".

3 Definitions

For the purposes of this ETS, the following definitions apply:

address: See CCITT Recommendation E.164 [1], clause 12.

basic service: See CCITT Recommendation Q.9 [5], definition 7018.

connected number: The ISDN number of the final destination (user C).

forwarded-to address: The address to which a call has been forwarded.

Forwarded-To Number (FTN): The ISDN number to which a call has been forwarded.

forwarded-to user: A user to whom the call is redirected as a result of forwarding.

forwarding cause: Parameter which contains the reason for the forwarding, e.g. due to the Call Forwarding Busy (CFB) supplementary service, the CFU supplementary service, the Call Forwarding No Reply (CFNR) supplementary service, or the Call Deflection (CD) supplementary service.

forwarding indicator: Indicator showing that call has been forwarded and indicating whether this information should be given to calling user.

forwarding number: The ISDN number of the served user.

Integrated Services Digital Network (ISDN): See ITU-T Recommendation I.112 [2], definition 308.

ISDN number: A number conforming to the numbering plan and structure specified in CCITT Recommendation E.164 [1].

originally called number: The ISDN number of user B.

Presentation Indicator (PI): Indicator showing whether the FTN should be presented to the calling user, as derived from the Connected Line Identification Restriction (COLR) supplementary service of user C.

served user: The user to whom the CFU supplementary service is provided.

service; telecommunication service: See ITU-T Recommendation I.112 [2], definition 201.

supplementary service: See ITU-T Recommendation I.210 [4], subclause 2.4.

user A: The calling user in a call which is subject to diversion.

user B: The served user when a call (from user A) is subject to the CFU supplementary service.

user C: The forwarded-to user in a call which is subject to the CFU supplementary service. In the case of a call which is subject to multiple diversions, user C is the forwarded-to user with respect to the final call forwarding.

4 Abbreviations

For the purposes of this ETS, the following abbreviations apply:

CC	Call Control
CCA	Call Control Agent
CD	Call Deflection
CFB	Call Forwarding Busy
CFNR	Call Forwarding No Reply
CFU	Call Forwarding Unconditional
COLR	Connected Line Identification Restriction
FE	Functional Entity
FEA	Functional Entity Action
FTN	Forwarded-To Number
ISDN	Integrated Services Digital Network
LE	Local Exchange
NSO	Notification Subscription Option
PI	Presentation Indicator
PTNX	Private Telecommunication Network eXchange
SCE	Service Control Entity
SCM	Service Control Model
SDL	Specification and Description Language
SSC	Supplementary Service Control
TE	Terminal Equipment

5 Description

The general description of the CFU supplementary service is specified in ETS 300 200 [9], clause 5.

6 Derivation of the functional model

6.1 Functional model description

The functional model for the CFU supplementary service is shown in figure 1.

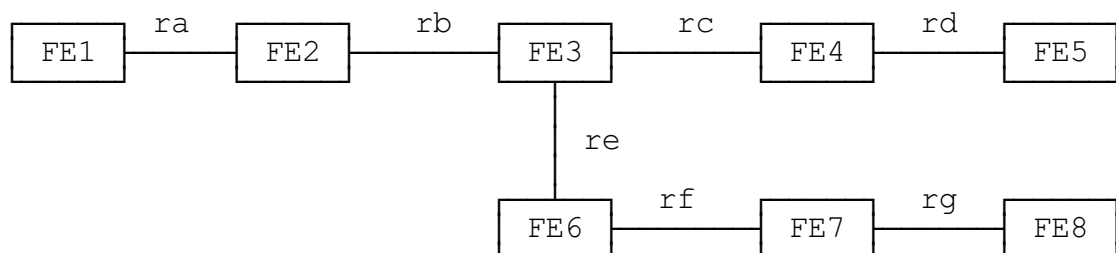

Figure 1: Functional model

6.2 Description of the FEs

The FEs required by the CFU supplementary service in addition to those of the basic call are as follows:

- FE1: Calling user's service agent;
- FE2: Calling user's Service Control Entity (SCE);
- FE3: Call forwarding execution entity;
- FE4: Call forwarding detection and control entity;
- FE5: Served user's service agent;
- FE6: Interface controlling entity;
- FE7: Forwarded-to user's SCE;
- FE8: Forwarded-to user's service agent.

6.3 Relationship with a basic service

Relationship with a basic service is shown in figure 2.

NOTE: The basic call model is defined in CCITT Recommendation Q.71 [7], § 2.1, with the exception that r1 represents an outgoing call relationship from a Call Control Agent (CCA) and r3 represents an incoming call relationship to a CCA.

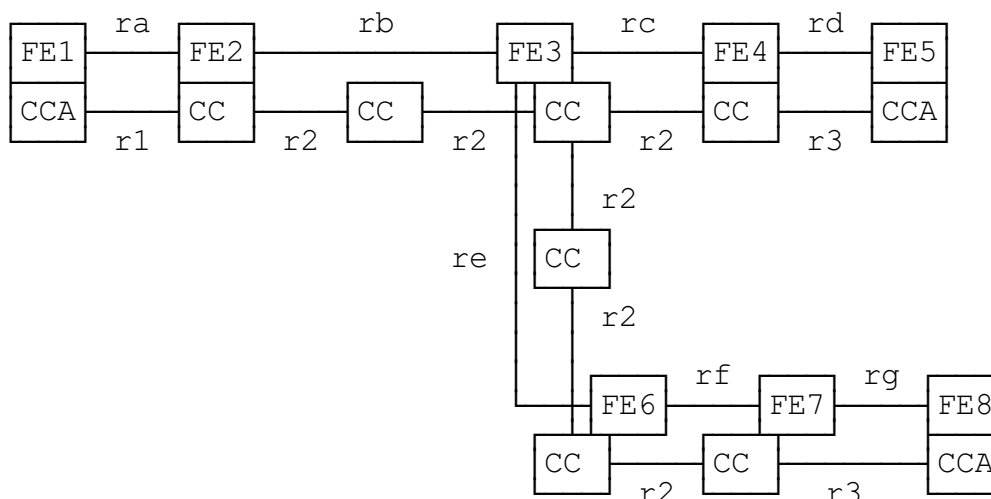

Figure 2: Relationship with a basic service

7 Information flows

7.1 Information flow diagrams

Figures 3 and 4 contain the information flows for the CFU supplementary service.

The following notes are related to figures 3 and 4.

NOTE 1: The INFORM5 req.ind is not later presented to FE8 than the associated SETUP req.ind.

NOTE 2: In case of:

- temporary mode of the COLR supplementary service activated at user C; or
- immediately responding terminal at user C,

the value of PI is determined on receipt of SETUP resp.conf from FE8.

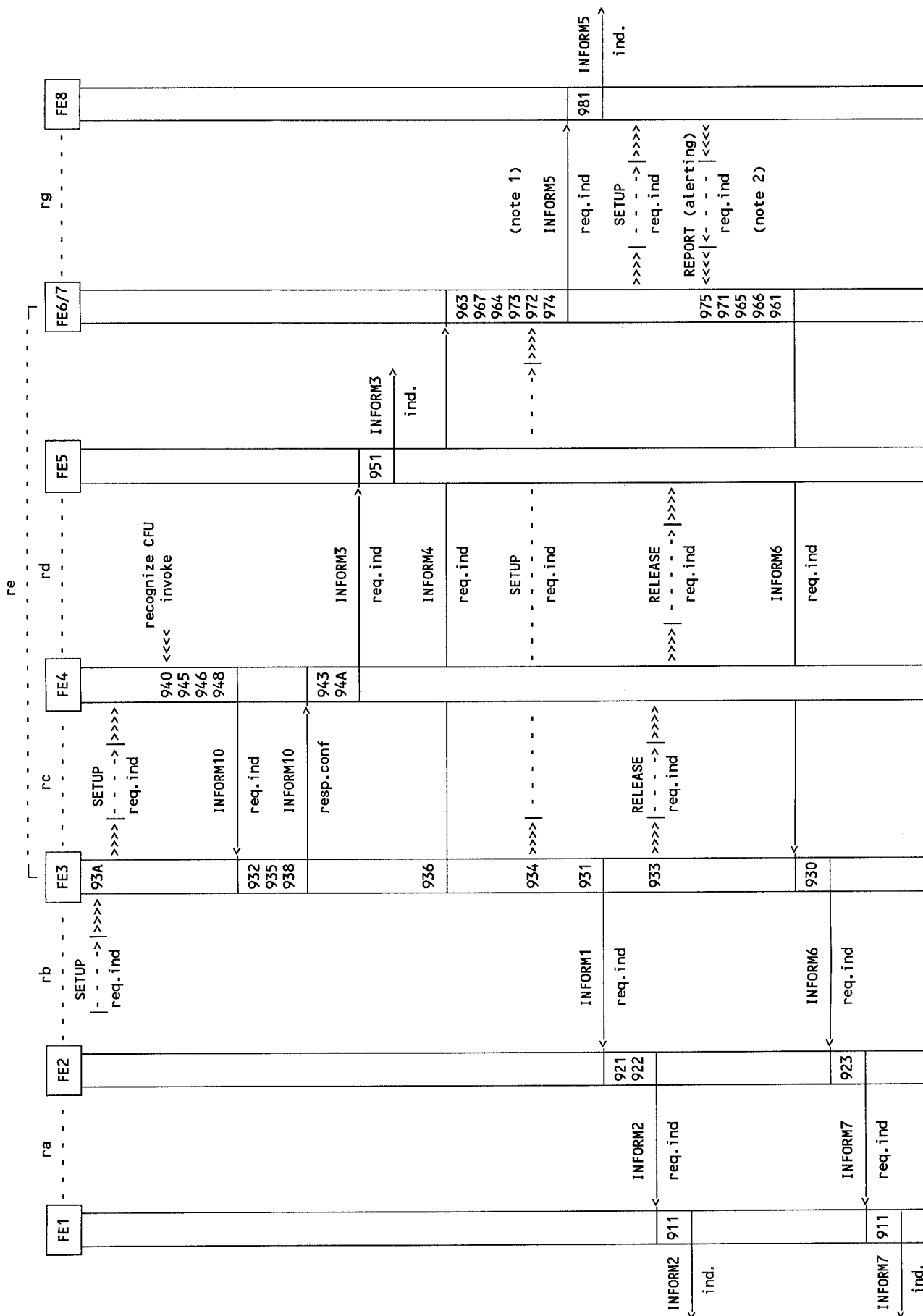

Figure 3: CFU supplementary service

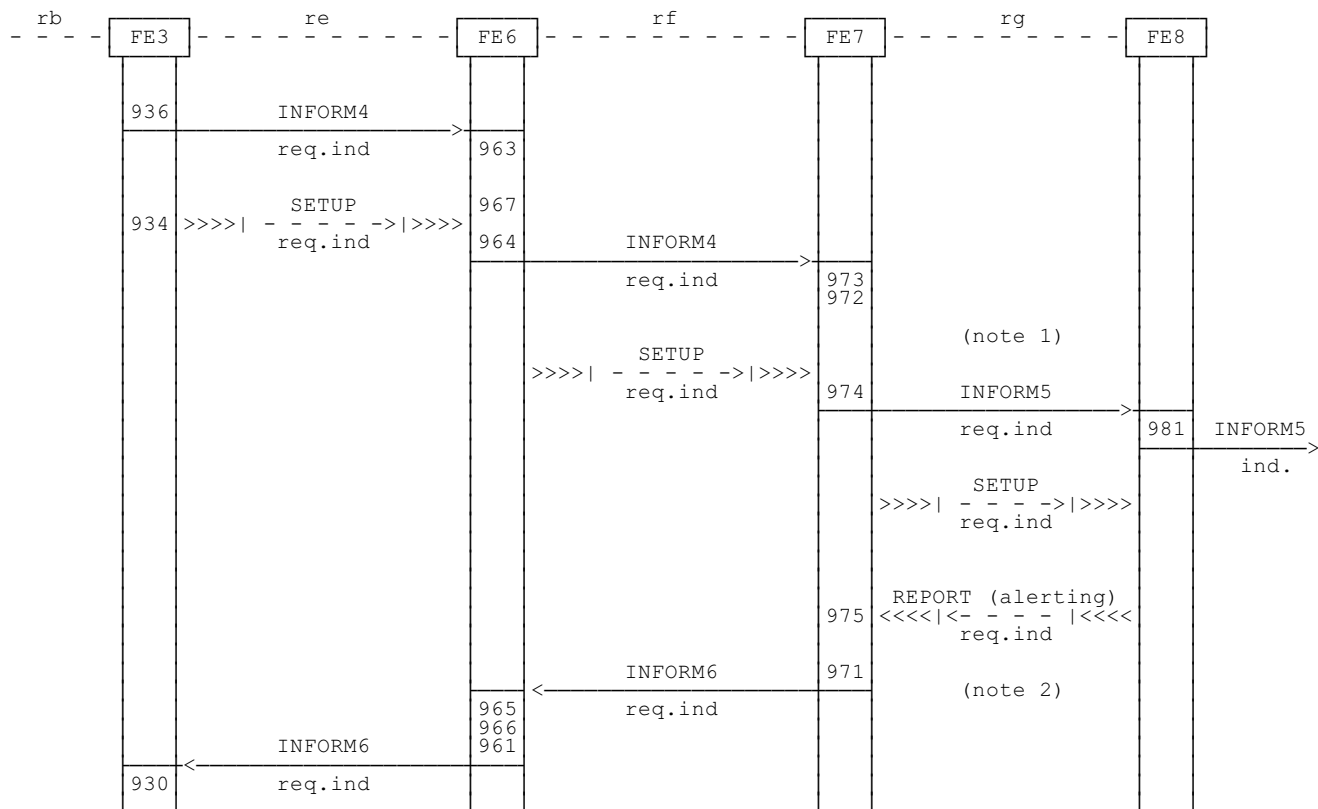

Figure 4: Flows across the public/private network interface at user C

7.2 Definition of individual information flows

7.2.1 Relationship ra

7.2.1.1 Contents of INFORM2

The content of INFORM2 is shown in table 1.

Table 1

Parameter	Allowed value	req.ind
forwarding indicator		M

7.2.1.2 Contents of INFORM7

The content of INFORM7 is shown in table 2.

Table 2

Parameter	Allowed value	req.ind
FTN FTN PI	ISDN number - number restricted - number not available - number allowed	M (note) M
NOTE: Only present if PI = number allowed.		

7.2.2 Relationship rb

7.2.2.1 Contents of INFORM1

The content of INFORM1 is shown in table 3.

Table 3

Parameter	Allowed value	req.ind
forwarding indicator including Notification Subscription Option (NSO)	- No - Yes, without FTN - Yes, with FTN	M
forwarding cause FTN (note)	CFU	M O
NOTE: This option refers to the situation in which the FTN is withheld on the basis of a network-provider decision.		

7.2.2.2 Contents of INFORM6

The content of INFORM6 is shown in table 4.

Table 4

Parameter	Allowed value	req.ind
PI	- presentation allowed - presentation not allowed	M

7.2.3 Relationship rc

7.2.3.1 Contents of INFORM10 (rerouteing request)

NOTE: All the information necessary to FE3 to launch the forwarded call is included in the INFORM10.

The content of INFORM10 is shown in table 5.

Table 5

Parameter	Allowed value	req.ind	resp.conf
cause for forwarding	CFU	M	
forwarded-to address		M	
forwarding indicator		M	
forwarding number		O	
restriction indicator for forwarding number		M	
telecommunications service information		M	
user-to-user information		O	
forwarding counter		M	
calling party subaddress		O	
forwarding invocation result	positive/negative acknowledgement		M
reason for rejection	(note)		O
NOTE:	Possible reasons are: "service not subscribed", "service not available", "service not implemented", "resource unavailable", "invalid FTN", "FTN is operator access", "FTN is special service ISDN number", "FTN is served user's ISDN number", "number of diversions exceeded".		

7.2.4 Relationship rd

7.2.4.1 Contents of INFORM3

The content of INFORM3 is shown in table 6.

NOTE: The sending of INFORM3 depends on the subscription options of the served user. It contains all information necessary to identify the served user, e.g. the served user's number including all direct dialling in digits.

Table 6

Parameter	Allowed value	req.ind
served user's address		M
user-to-user information (if available)		M
forwarding cause	CFU	M
telecommunications service information		M
calling party address (note 2)	- address	O
	- number restricted	
	- number not available	
last forwarding number (note 3)	- ISDN number	M (note 1)
	- number restricted	
	- number not available	
cause for last forwarding		M (note 1)
originally called number (note 3)	- ISDN number	M (note 1)
	- number restricted	
	- number not available	
NOTE 1: Only applicable in case of multiple forwarding.		
NOTE 2: The calling party address shall be included if required by the calling line identification presentation supplementary service, if not restricted.		
NOTE 3: This ISDN number shall only be included if no restrictions exist.		

7.2.5 Relationship re

7.2.5.1 Contents of INFORM4

The content of INFORM4 is shown in table 7.

Table 7

Parameter	Allowed value	req.ind
forwarding cause	CFU	M
forwarding number (note)		M
forwarding counter		M
originally called number (note)		M
NOTE: This ISDN number shall always be transferred in the network together with a "restriction indicator" whose value is set according to the subscription options of the user. On boundaries between different networks or to private networks the ISDN number need not be passed depending on a network-provider decision.		

7.2.5.2 Contents of INFORM6

The content of INFORM6 is shown in table 8.

Table 8

Parameter	Allowed value	req.ind
PI for FTN	- presentation allowed - presentation not allowed	M

7.2.6 Relationship rf

7.2.6.1 Contents of INFORM4

The content of INFORM4 is shown in table 9.

Table 9

Parameter	Allowed value	req.ind
forwarding cause	CFU	M
forwarding number (note)		M
forwarding counter		M
originally called number (note)		M
NOTE:	This ISDN number shall always be transferred in the network together with a "restriction indicator" whose value is set according to the subscription options of the user. On boundaries between different networks or to private networks the ISDN number need not be passed depending on a network-provider decision.	

7.2.6.2 Contents of INFORM6

The content of INFORM6 is shown in table 10.

Table 10

Parameter	Allowed value	req.ind
PI for FTN	- presentation allowed - presentation not allowed	M

7.2.7 Relationship rg

7.2.7.1 Contents of INFORM5

The content of INFORM5 is shown in table 11.

Table 11

Parameter	Allowed value	req.ind
last forwarding cause		M
last forwarding number (note 1)	- ISDN number - number restricted - number not available	O
originally called number (note 1)	- ISDN number - number restricted - number not available	O
calling party address (note 2)	- address - number restricted - number not available	O
NOTE 1: This ISDN number shall only be included if no restrictions exist. NOTE 2: The calling party address shall be included if required by the calling line identification presentation supplementary service, if not restricted.		

8 SDL diagrams for FEs

All Specification and Description Language (SDL) diagrams for FEs are described according to CCITT Recommendation Z.100 [8].

NOTE: The notes to the figures within this clause refer to a basic call model defined in CCITT Recommendation Q.71 [7] with the exception that r1 represents only an outgoing call relationship from a CCA and r3 represents an incoming call relationship to a CCA.

8.1 FE1

The SDL diagram for FE1 is shown in figure 5.

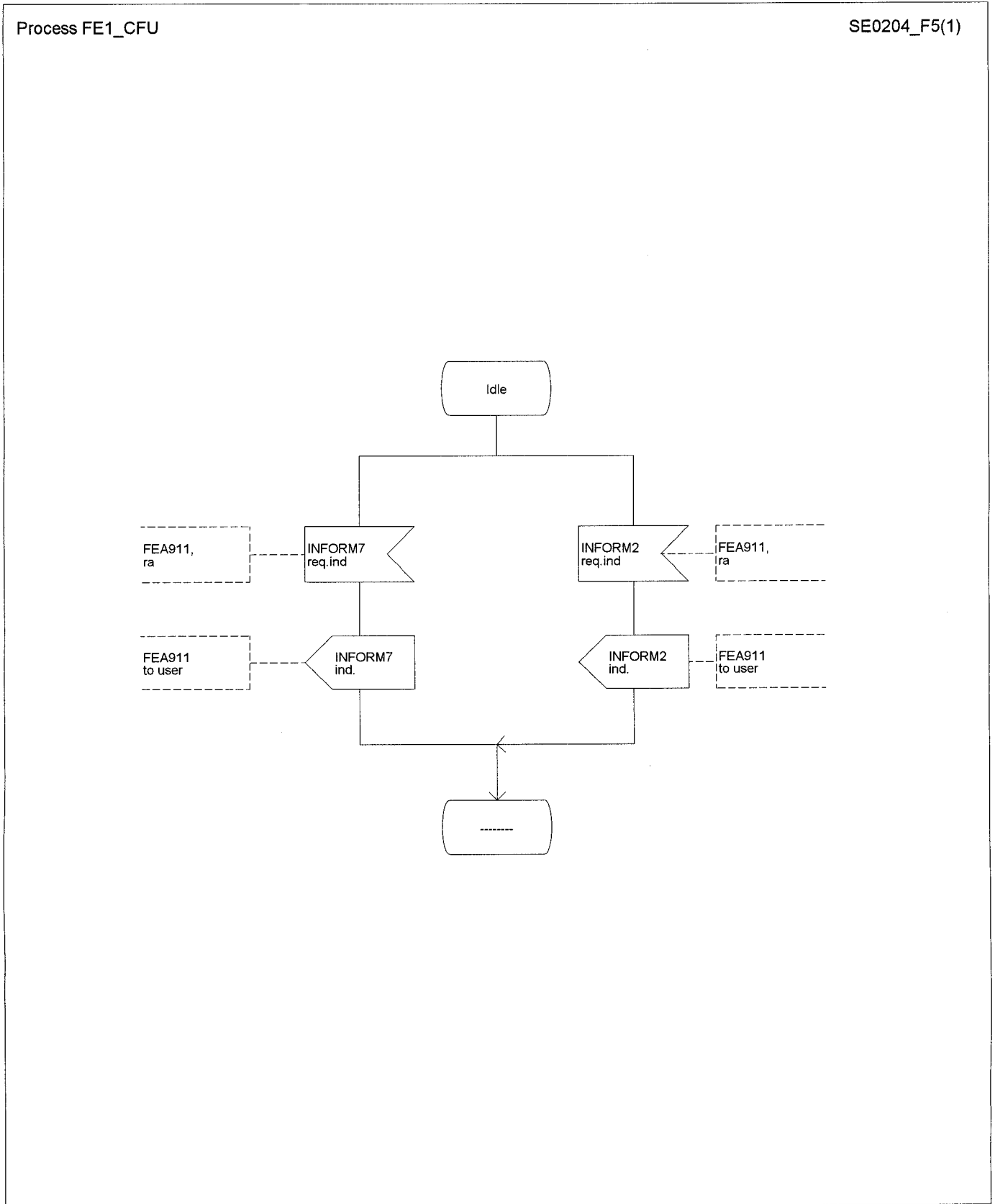

Figure 5

8.2 FE2

The SDL diagrams for FE2 are shown in figures 6 and 7.

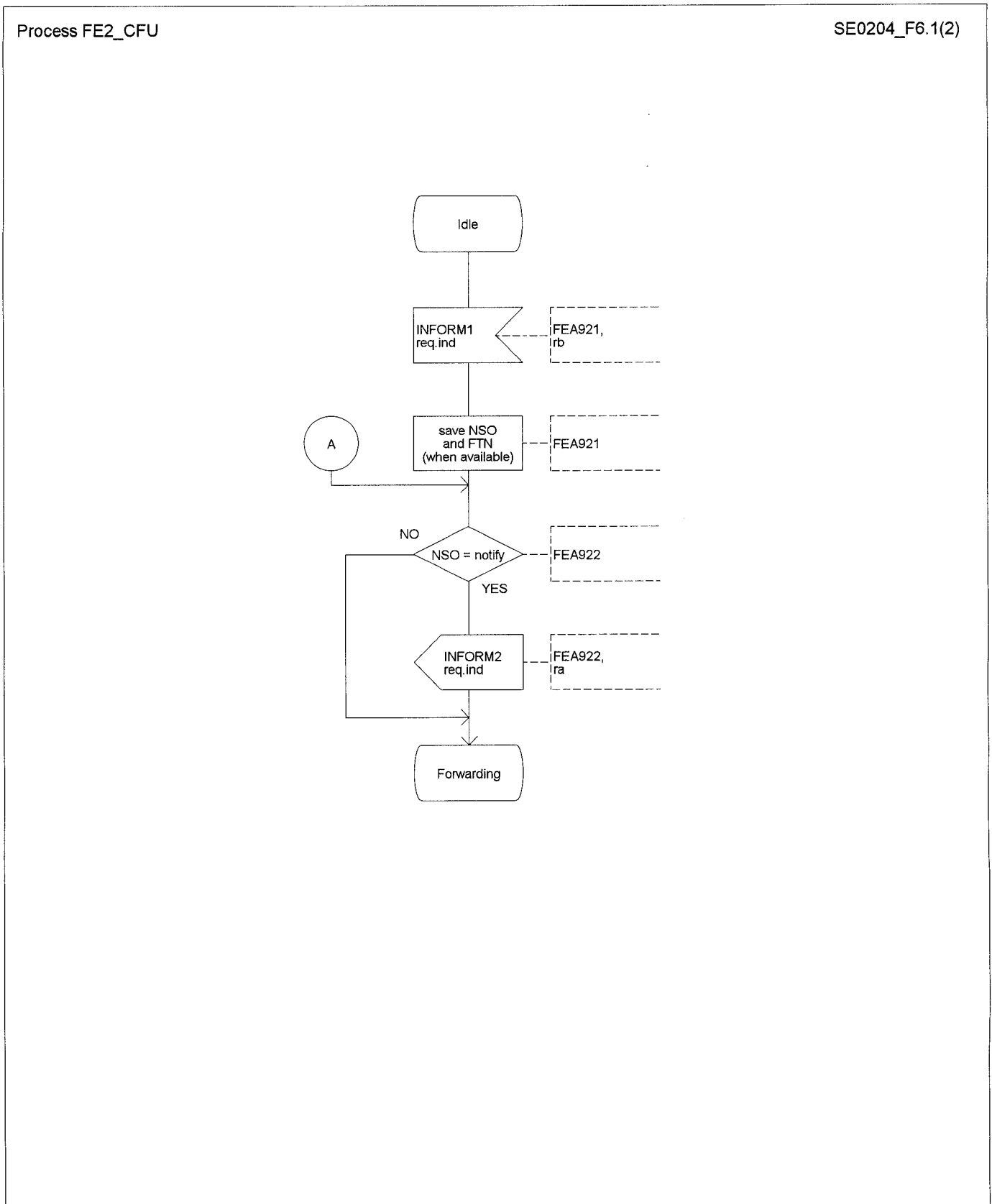

Figure 6 (sheet 1 of 2)

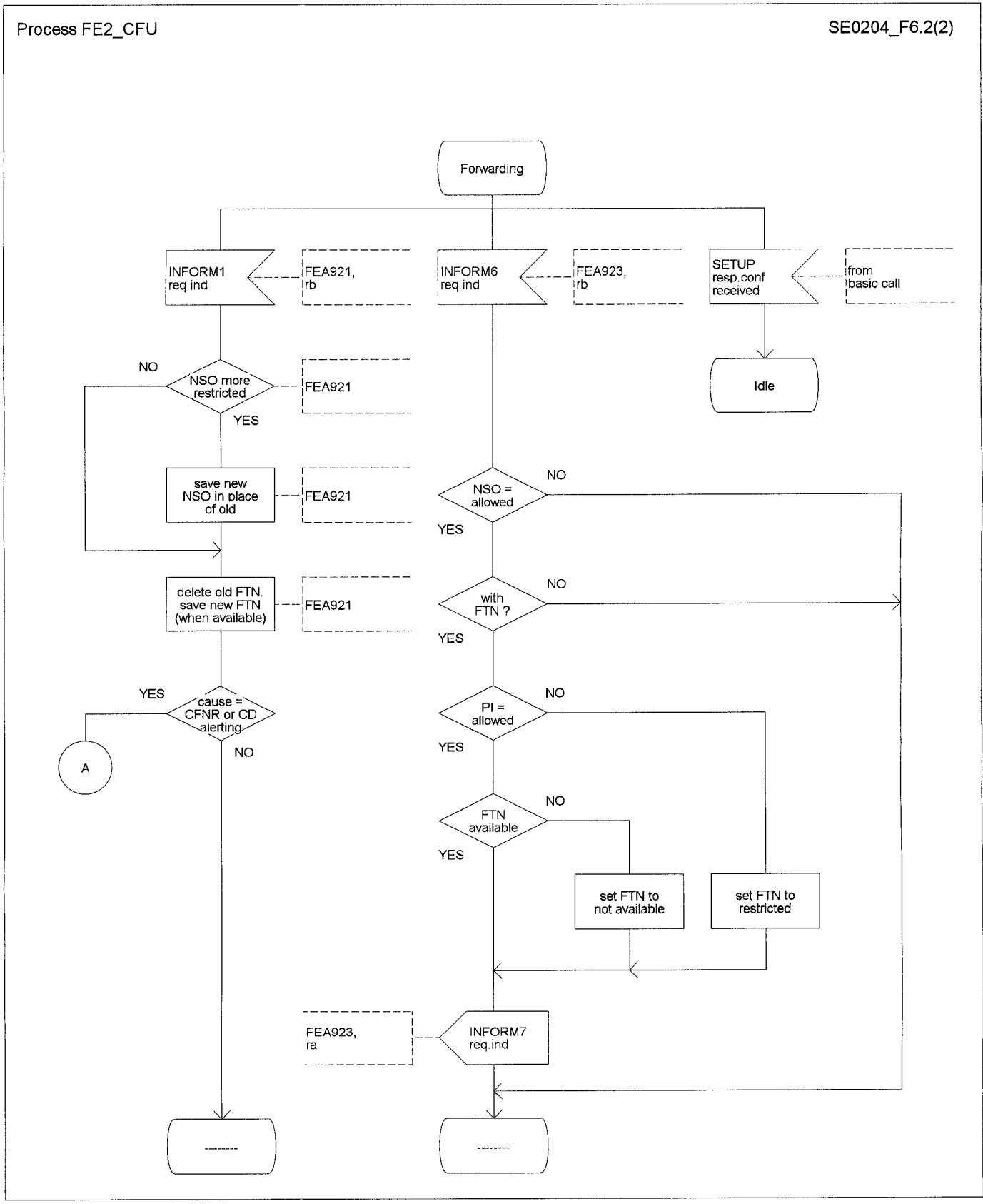

Figure 6 (sheet 2 of 2)

Process basic_call_CC

SE0204_F7(7)

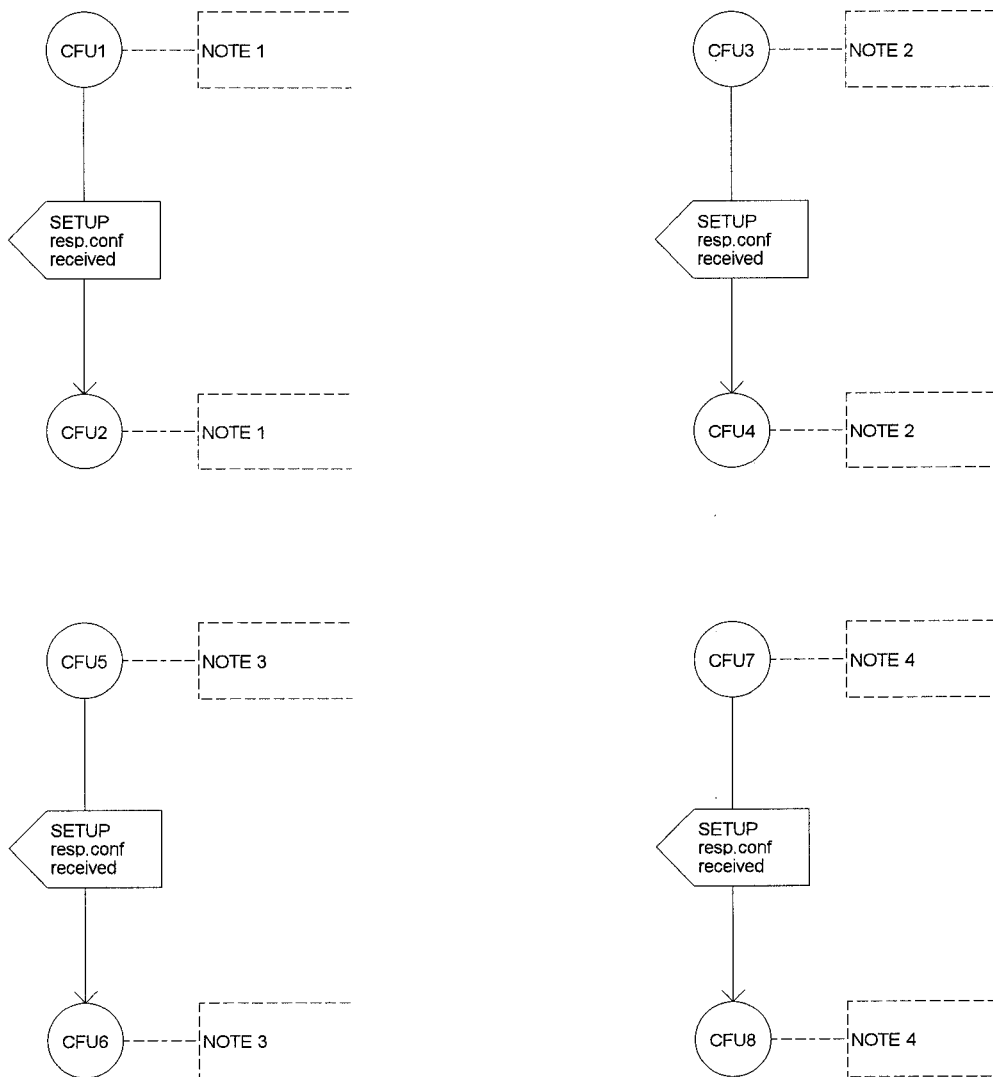

Figure 7

Notes to figure 7:

- NOTE 1: CFU1 and CFU2 break the basic call transition after receiving "SETUP resp.conf" (see figure 2-9 (sheet 3 of 19) of CCITT Recommendation Q.71 [7]). CFU2 reconnects at the same point.
- NOTE 2: CFU3 and CFU4 break the basic call transition after receiving "SETUP resp.conf" (see figure 2-9 (sheet 4 of 19) of CCITT Recommendation Q.71 [7]). CFU4 reconnects at the same point.
- NOTE 3: CFU5 and CFU6 break the basic call transition after receiving "SETUP resp.conf" (see figure 2-9 (sheet 15 of 19) of CCITT Recommendation Q.71 [7]). CFU6 reconnects at the same point.
- NOTE 4: CFU7 and CFU8 break the basic call transition after receiving "SETUP resp.conf" (see figure 2-9 (sheet 16 of 19) of CCITT Recommendation Q.71 [7]). CFU8 reconnects at the same point.

8.3 FE3

The SDL diagrams for FE3 are shown in figures 8 and 9.

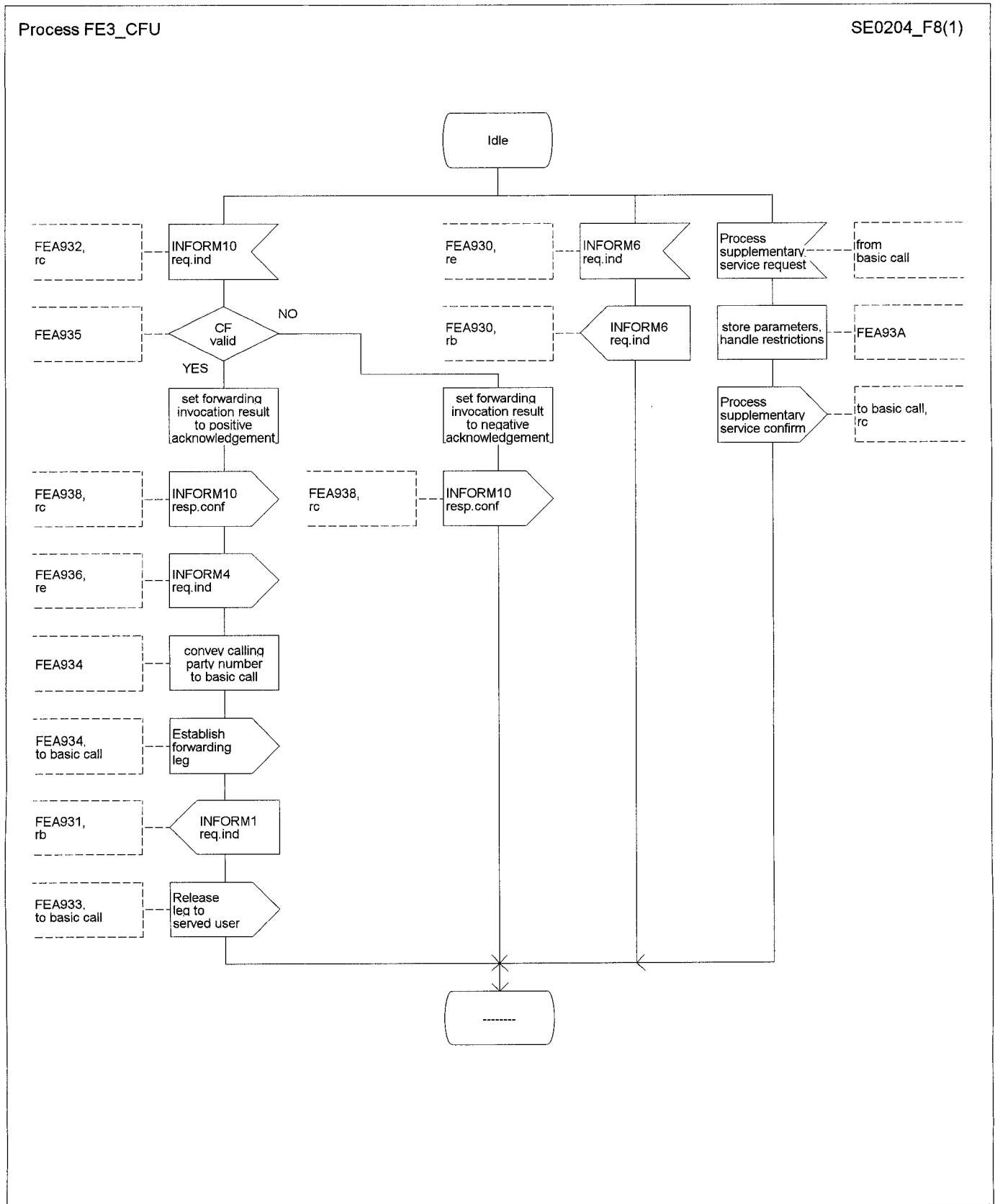

Figure 8

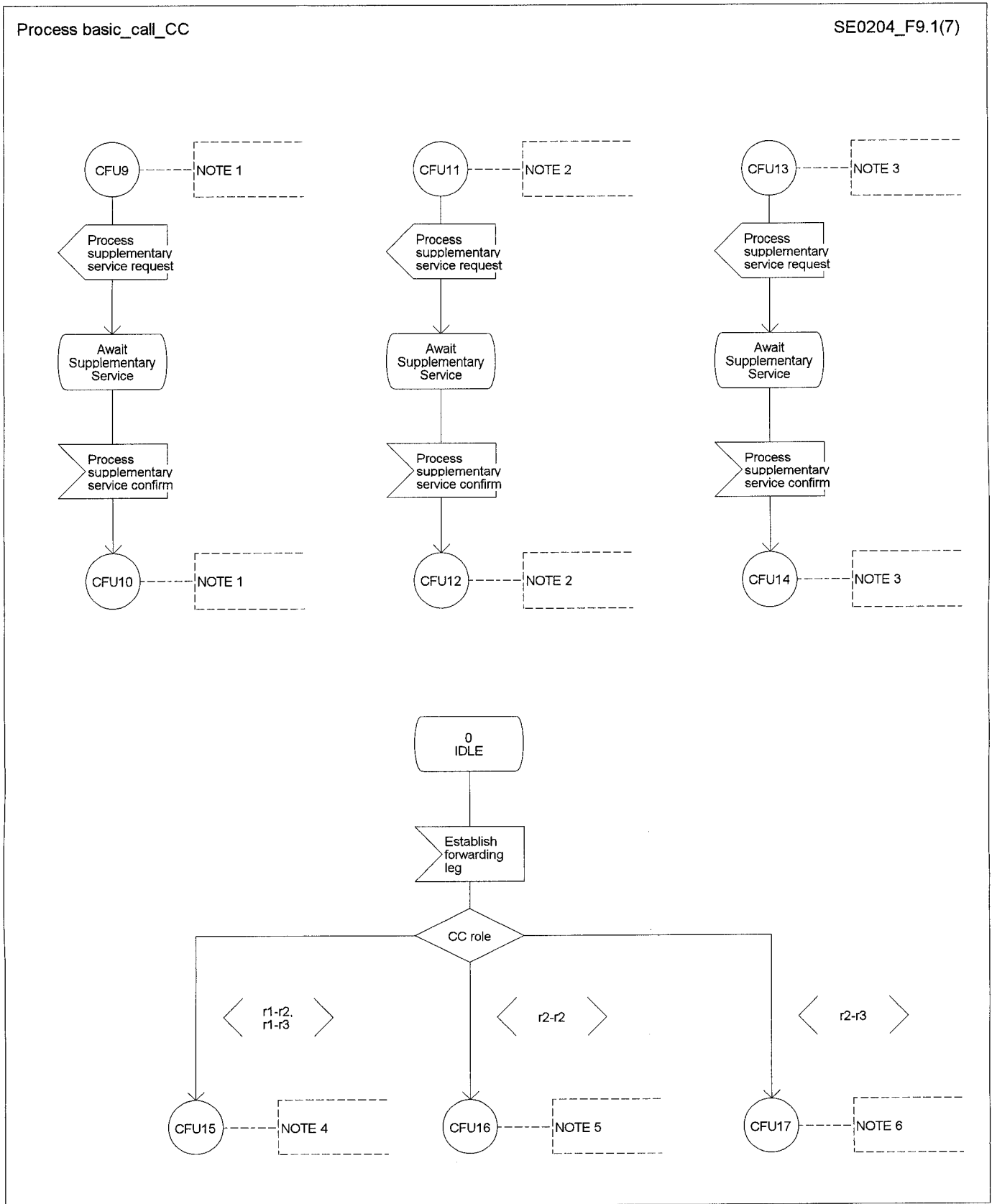

Figure 9 (sheet 1 of 2)

Process basic_call_CC

SE0204_F9.2(7)

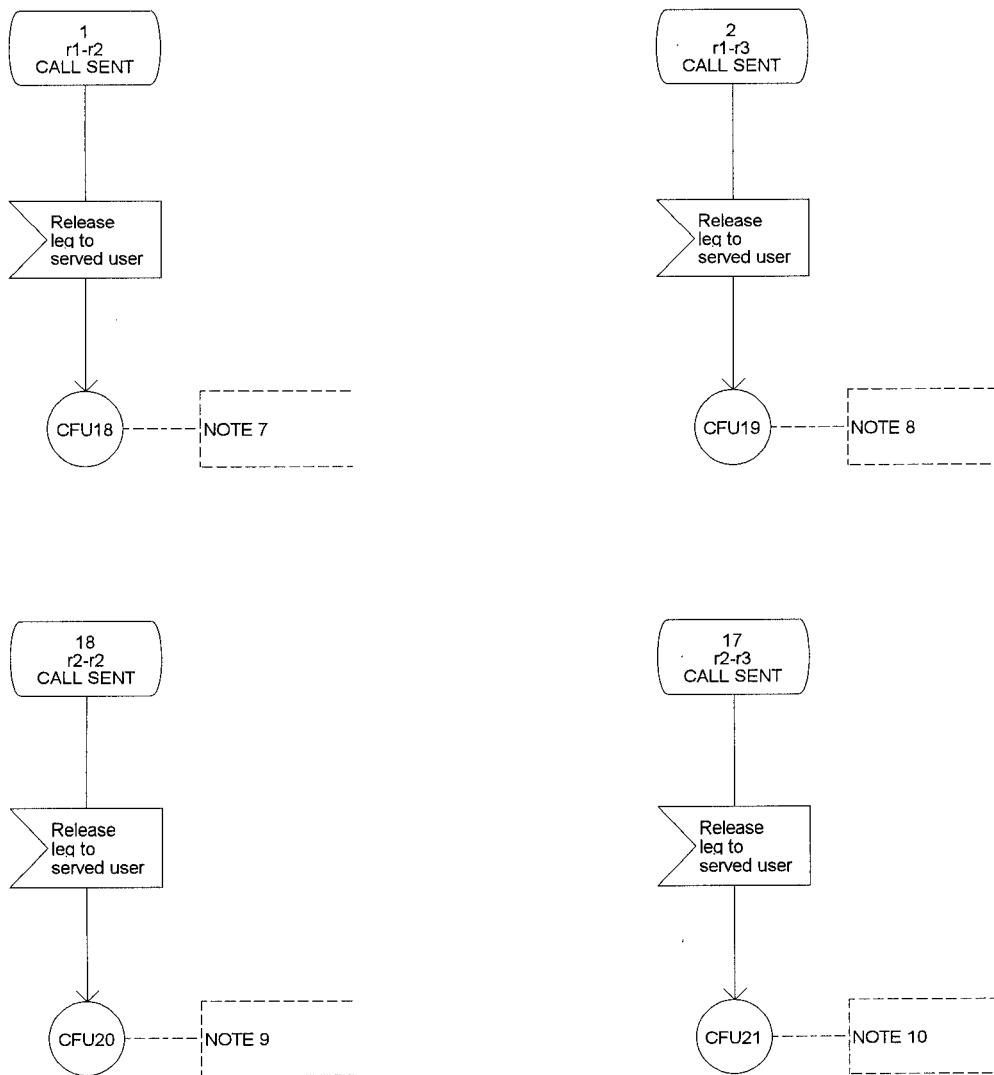

Figure 9 (sheet 2 of 2)

Notes to figure 9:

- NOTE 1: CFU9 and CFU10 break the basic call transition on the "Yes" branch of the decision "Successful?" following the task "Term. Screen. Process attempt" (see figure 2-9 (sheet 7 of 19) of CCITT Recommendation Q.71 [7]). CFU10 reconnects at the same point.
- NOTE 2: CFU11 and CFU12 break the basic call transition on the "Yes" branch of the decision "Successful?" following the task "Process attempt" (see figure 2-9 (sheet 7 of 19) of CCITT Recommendation Q.71 [7]). CFU12 reconnects at the same point.
- NOTE 3: CFU13 and CFU14 break the basic call transition following the output signal "PROCEEDING req.ind" (see figure 2-9 (sheet 1 of 19) of CCITT Recommendation Q.71 [7]). CFU14 reconnects at the same point.
- NOTE 4: CFU15 joins the basic call transition immediately following the task "Orig. screen. Process attempt" (see figure 2-9 (sheet 1 of 19) of CCITT Recommendation Q.71 [7]). Subsequent output signals "PROCEEDING req.ind" to the originating side (r1) are not sent.
- NOTE 5: CFU16 joins the basic call transition immediately following the "r2-r2" branch of the decision "CC role" (see figure 2-9 (sheet 7 of 19) of CCITT Recommendation Q.71 [7]). Elements of the task "Process attempt" relating to the originating side (r1) are not performed.
- NOTE 6: CFU17 joins the basic call transition immediately following the "r2-r3" branch of the decision "CC role" (see figure 2-9 (sheet 7 of 19) of CCITT Recommendation Q.71 [7]). Elements of the task "Term. Screen. Process attempt" relating to the originating side (r1) are not performed.
- NOTE 7: CFU18 joins the basic call transition immediately following the input signal "DISCONNECT req.ind" from the originating side (r1) (see figure 2-9 (sheet 3 of 19) of CCITT Recommendation Q.71 [7]). Subsequent output signals relating to the originating side (r1) are not sent.
- NOTE 8: CFU19 joins the basic call transition immediately following the input signal "DISCONNECT req.ind" from the originating side (r1) (see figure 2-9 (sheet 14 of 19) of CCITT Recommendation Q.71 [7]). Subsequent output signals relating to the originating side (r1) are not sent.
- NOTE 9: CFU20 joins the basic call transition immediately following the input signal "RELEASE req.ind" from the originating side (r2) (see figure 2-9 (sheet 11 of 19) of CCITT Recommendation Q.71 [7]). Subsequent output signals relating to the originating side (r2) are not sent.
- NOTE 10: CFU21 joins the basic call transition immediately following the input signal "RELEASE req.ind" from the originating side (r2) (see figures 2-9 (sheet 8 of 19) of CCITT Recommendation Q.71 [7]). Subsequent output signals relating to the originating side (r2) are not sent.

8.4 FE4

The SDL for FE4 are shown in figures 10 and 11.

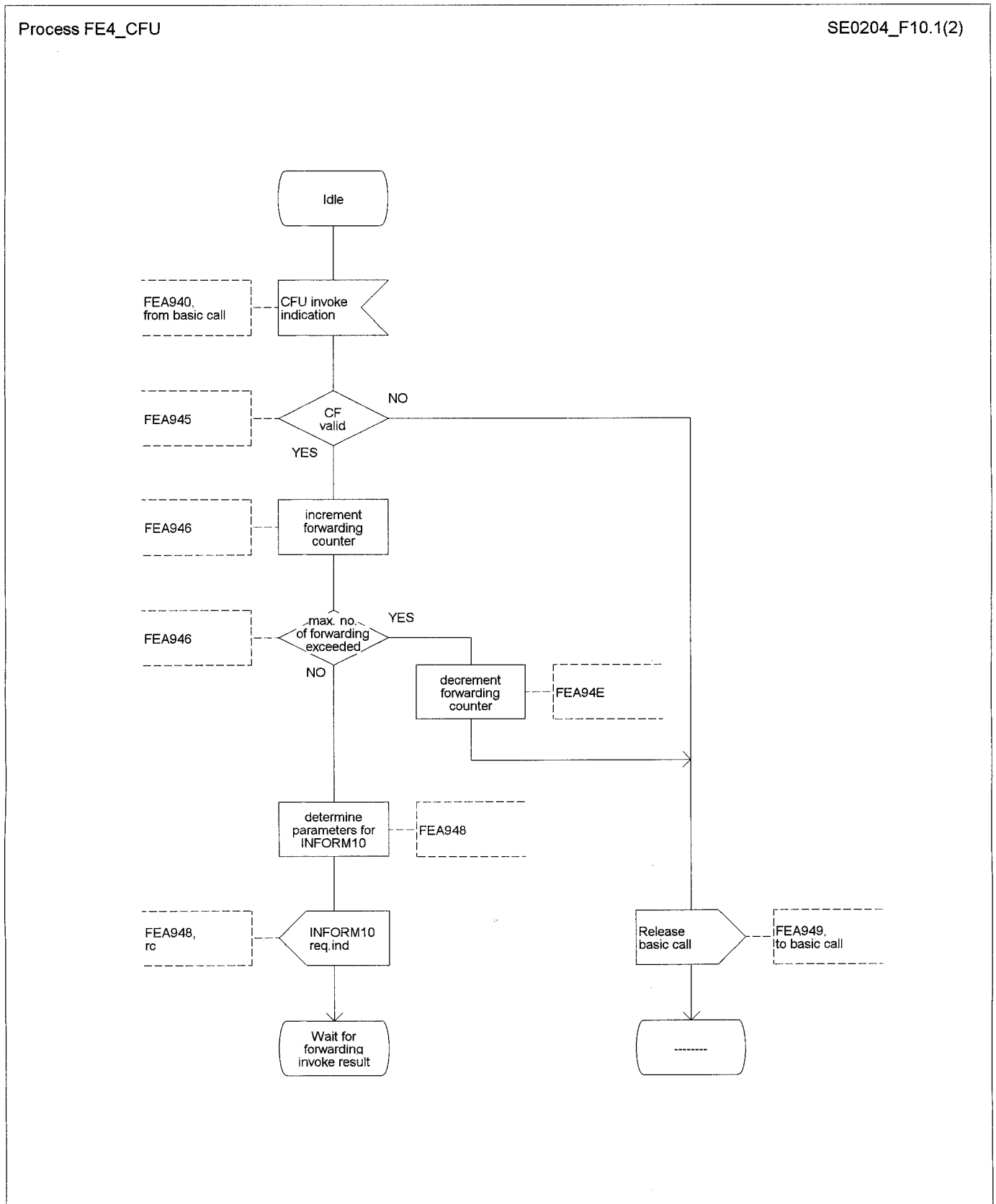

Figure 10 (sheet 1 of 2)

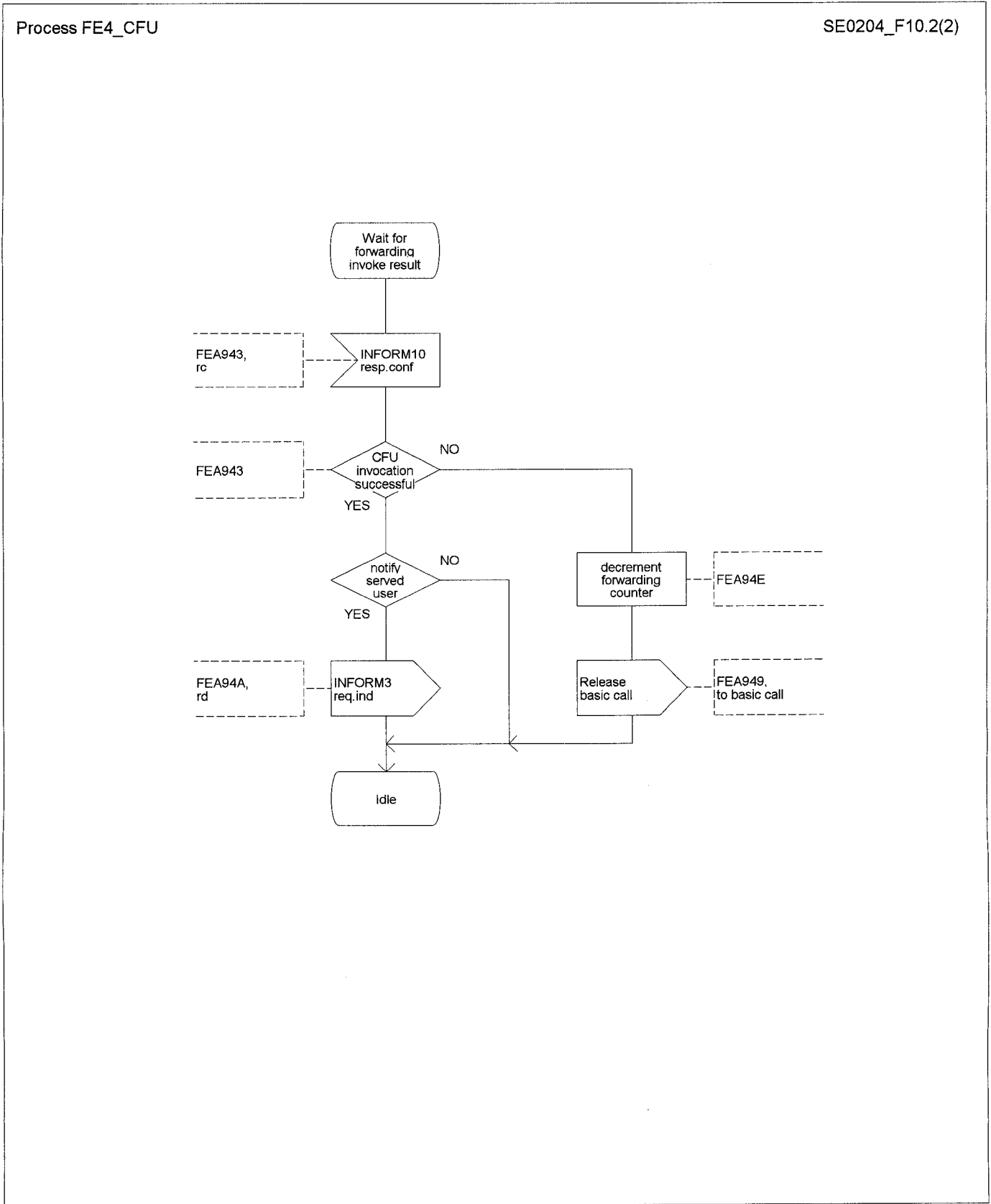

Figure 10 (sheet 2 of 2)

Process basic_call_CC

SE0204_F11(7)

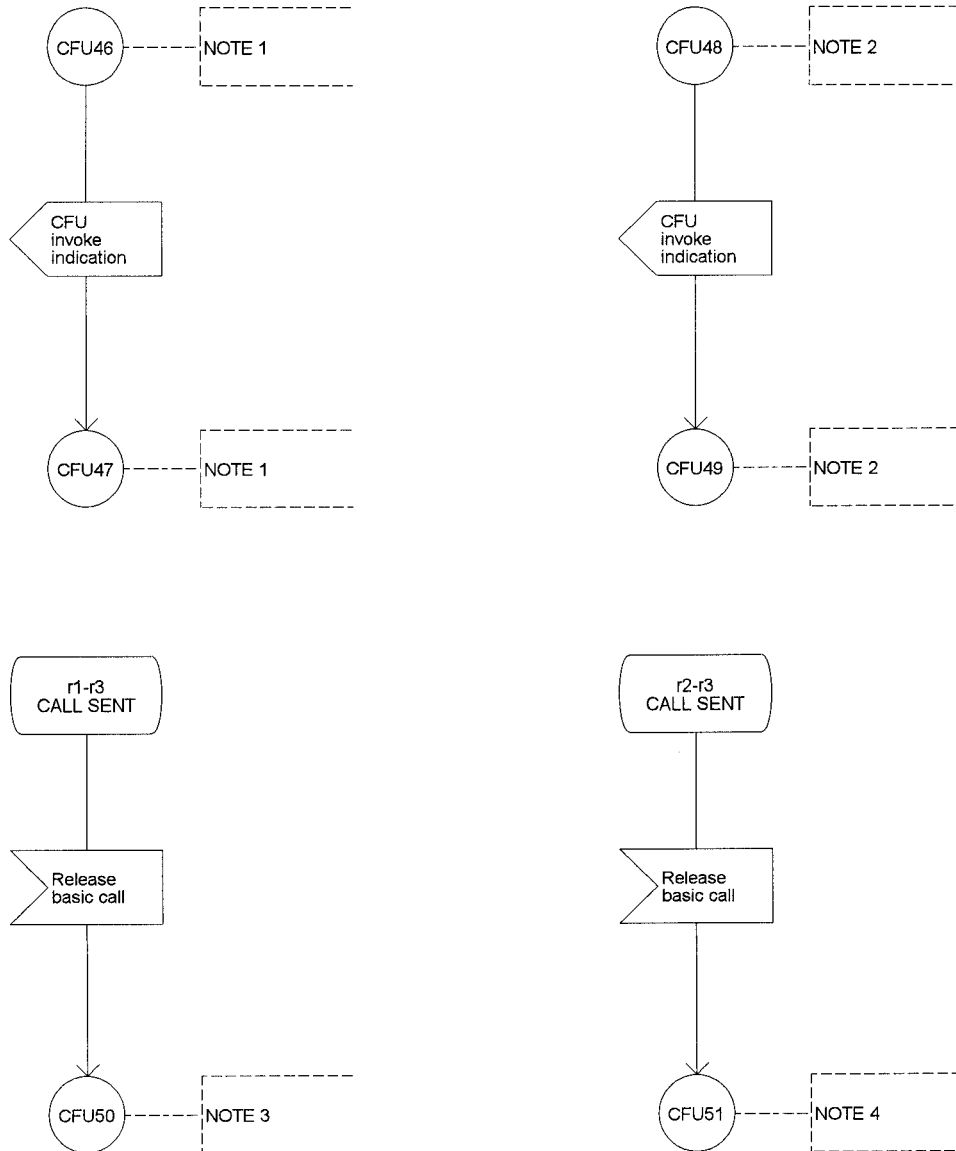

Figure 11

Notes to figure 11:

- NOTE 1: CFU46 and CFU47 break the basic call transition immediately following the "No" branch of the decision "Successful?" (see figure 2-9 (sheet 13 of 19) of CCITT Recommendation Q.71 [7]). CFU47 reconnects at the same point.
- NOTE 2: CFU48 and CFU49 break the basic call transition immediately following the "No" branch of the decision "Successful?" after task "Term. Screen. Process attempt" (see figure 2-9 (sheet 7 of 19) of CCITT Recommendation Q.71 [7]). CFU49 reconnects at the same point.
- NOTE 3: CFU50 joins the basic call transition immediately following the input signal "DISCONNECT req.ind" from the destination side (r3) (see figure 2-9 (sheet 14 of 19) of CCITT Recommendation Q.71 [7]). Subsequent signals are not sent to the destination side (r3).
- NOTE 4: CFU51 joins the basic call transition immediately following the input signal "DISCONNECT req.ind" from the destination side (r3) (see figure 2-9 (sheet 14 of 19) of CCITT Recommendation Q.71 [7]). Subsequent signals are not sent to the destination side (r3).

8.5 FE5

The SDL diagram for FE5 is shown in figure 12.

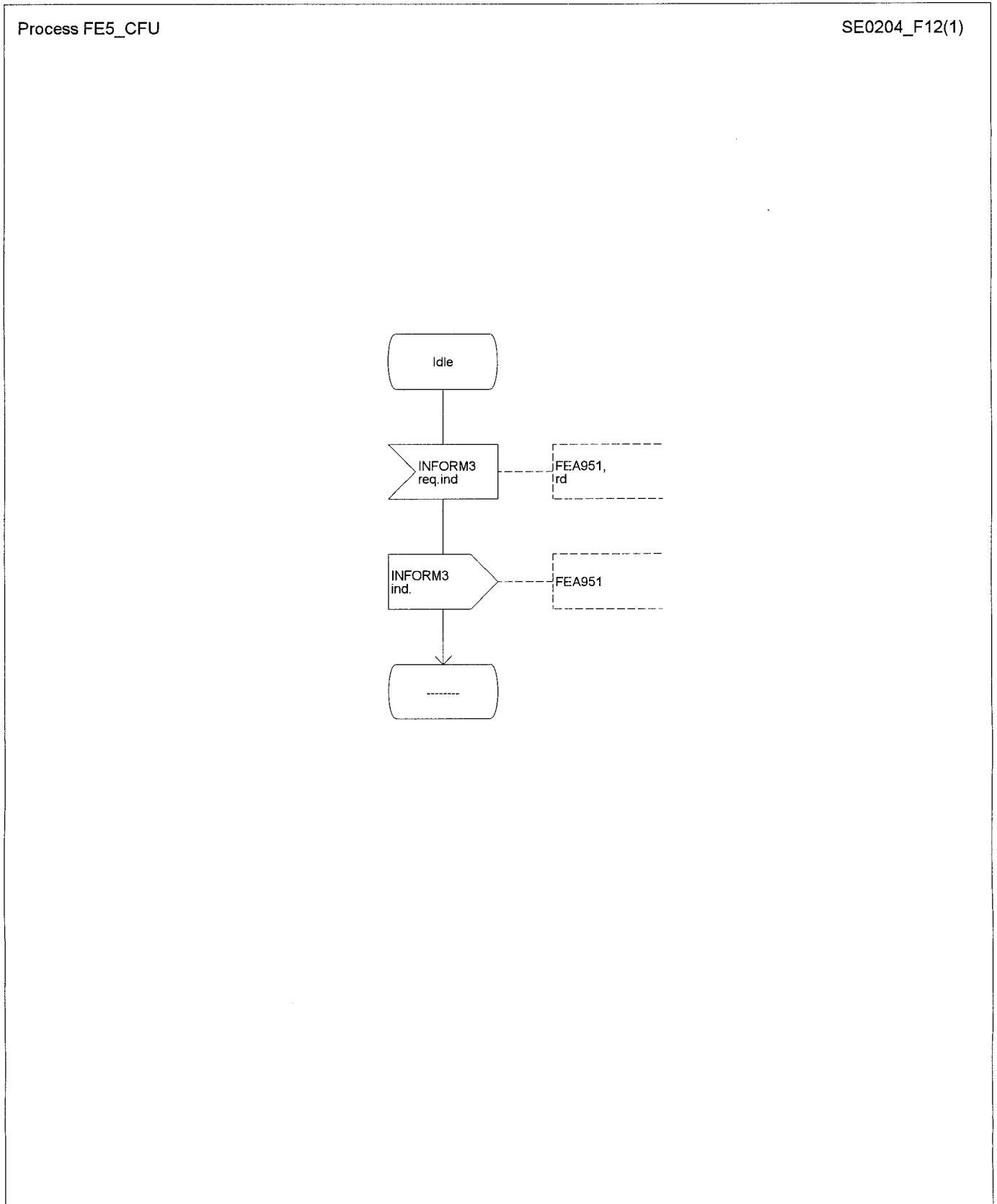

Figure 12

8.6 FE6

The SDL diagrams for FE6 are shown in figures 13 and 14.

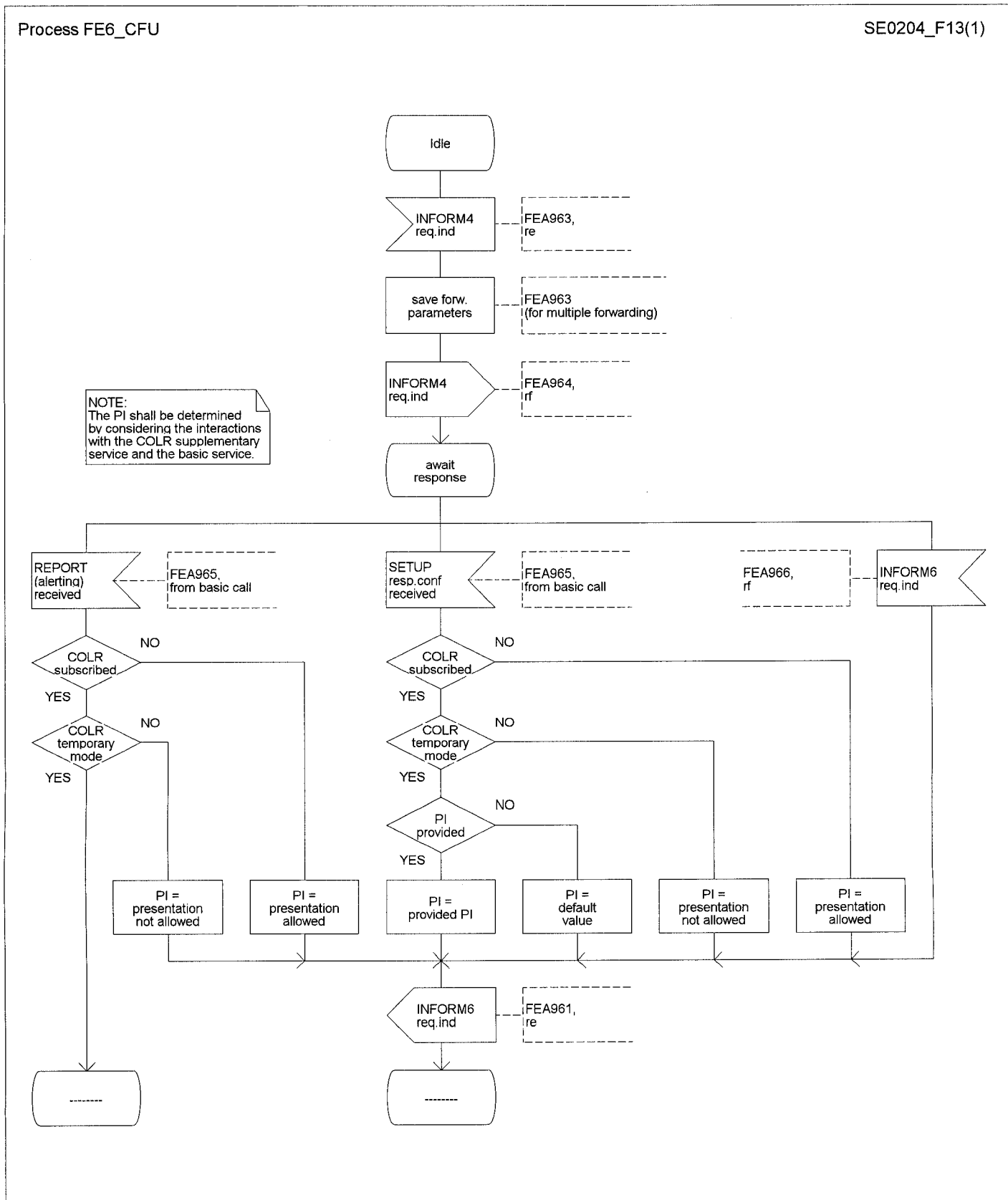

Figure 13

Process basic_call_CC

SE0204_F14.1(7)

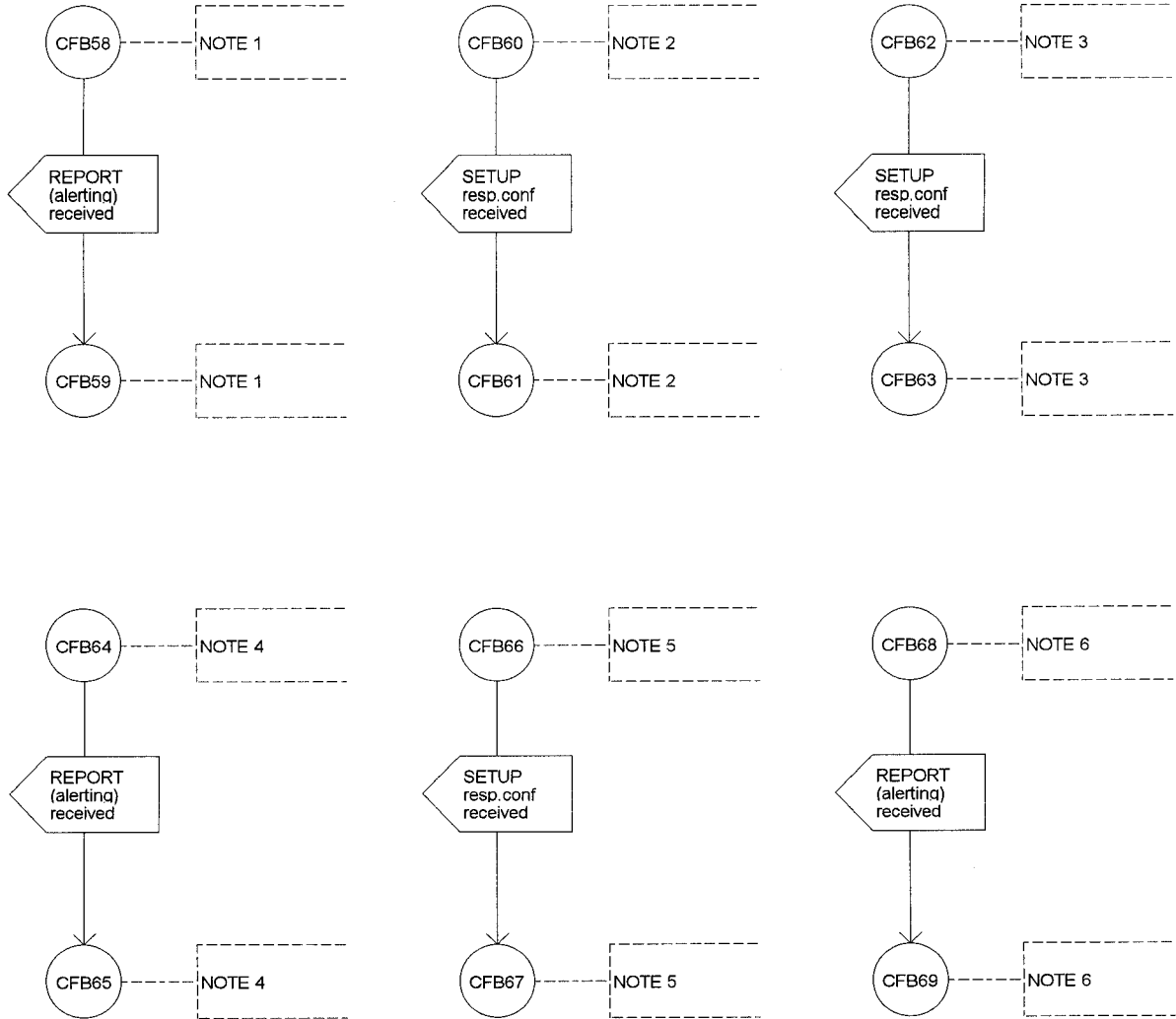

Figure 14 (sheet 1 of 2)

Process basic_call_CC

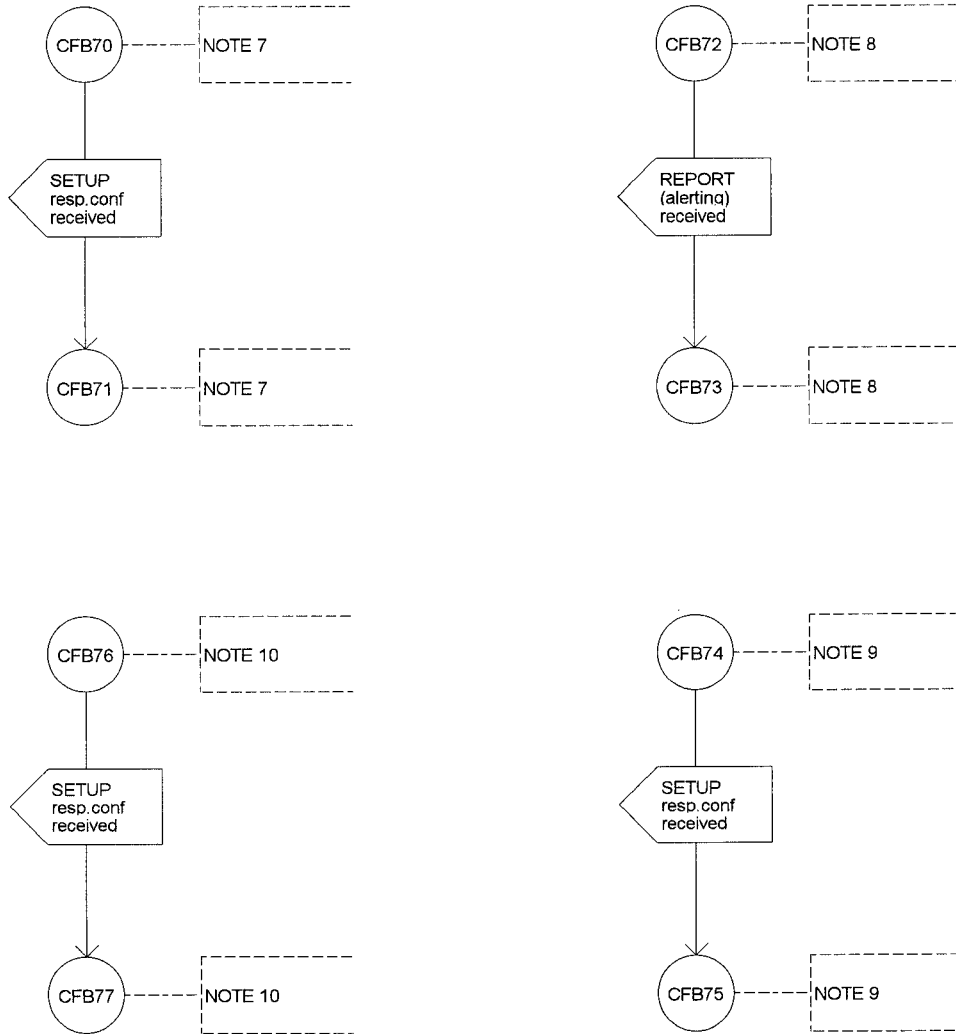

Figure 14 (sheet 2 of 2)

Notes to figure 14:

- NOTE 1: CFU58 and CFU59 break the basic call transition following the receipt of input signal "REPORT (alerting) req.ind" (see figure 2-9 (sheet 3 of 19) of CCITT Recommendation Q.71 [7]). CFU59 reconnects at the same point.
- NOTE 2: CFU60 and CFU61 break the basic call transition following the receipt of input signal "SETUP resp.conf" (see figure 2-9 (sheet 3 of 19) of CCITT Recommendation Q.71 [7]). CFU61 reconnects at the same point.
- NOTE 3: CFU62 and CFU63 break the basic call transition following the receipt of input signal "SETUP resp.conf" (see figure 2-9 (sheet 4 of 19) of CCITT Recommendation Q.71 [7]). CFU63 reconnects at the same point.
- NOTE 4: CFU64 and CFU65 break the basic call transition following the receipt of input signal "REPORT (alerting) req.ind" (see figure 2-9 (sheet 8 of 19) of CCITT Recommendation Q.71 [7]). CFU65 reconnects at the same point.
- NOTE 5: CFU66 and CFU67 break the basic call transition following the receipt of input signal "SETUP resp.conf" (see figure 2-9 (sheet 8 of 19) of CCITT Recommendation Q.71 [7]). CFU67 reconnects at the same point.
- NOTE 6: CFU68 and CFU69 break the basic call transition following the receipt of input signal "REPORT (alerting) req.ind" (see figure 2-9 (sheet 11 of 19) of CCITT Recommendation Q.71 [7]). CFU69 reconnects at the same point.
- NOTE 7: CFU70 and CFU71 break the basic call transition following the receipt of input signal "SETUP resp.conf" (see figure 2-9 (sheet 11 of 19) of CCITT Recommendation Q.71 [7]). CFU71 reconnects at the same point.
- NOTE 8: CFU72 and CFU73 break the basic call transition following the receipt of input signal "REPORT (alerting) req.ind" (see figure 2-9 (sheet 14 of 19) of CCITT Recommendation Q.71 [7]). CFU73 reconnects at the same point.
- NOTE 9: CFU74 and CFU75 break the basic call transition following the receipt of input signal "SETUP resp.conf" (see figure 2-9 (sheet 15 of 19) of CCITT Recommendation Q.71 [7]). CFU75 reconnects at the same point.
- NOTE 10: CFU76 and CFU77 break the basic call transition following the receipt of input signal "SETUP resp.conf" (see figure 2-9 (sheet 16 of 19) of CCITT Recommendation Q.71 [7]). CFU77 reconnects at the same point.

8.7 FE7

The SDL diagrams for FE7 are shown in figures 15 and 16.

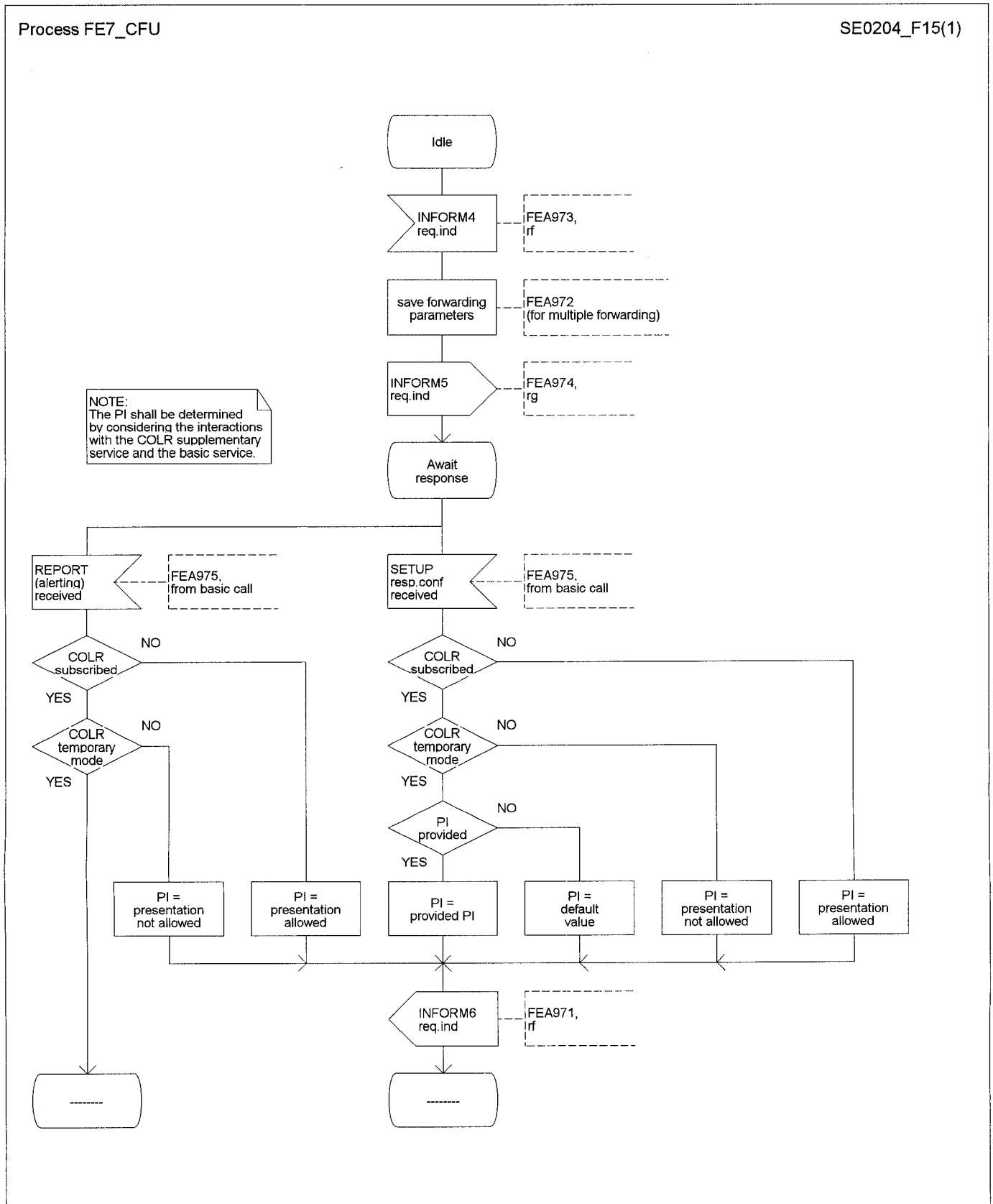

Figure 15

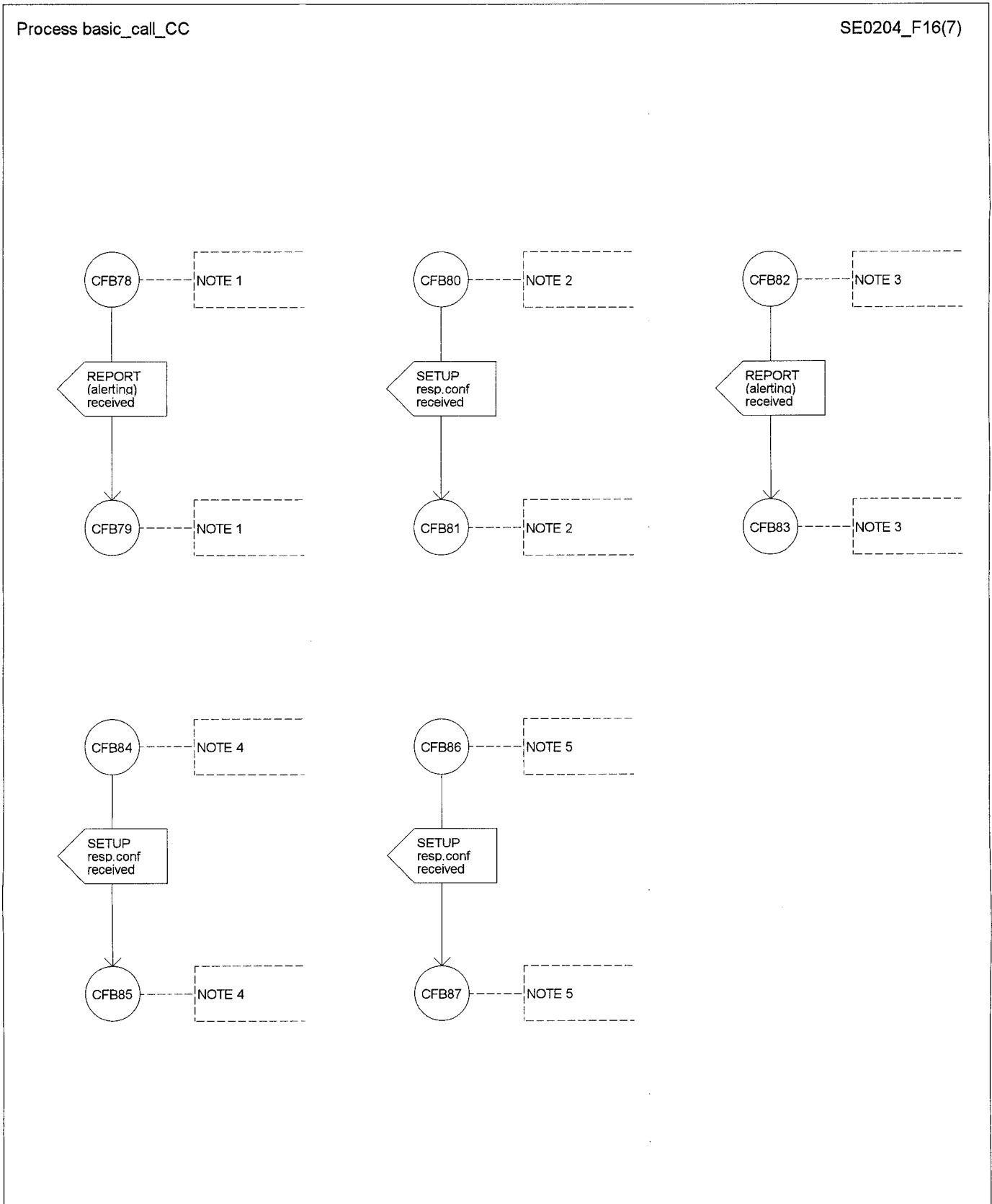

Figure 16

Notes to figure 16:

- NOTE 1: CFU78 and CFU79 break the basic call transition following the receipt of input signal "REPORT (alerting) req.ind" (see figure 2-9 (sheet 8 of 19) of CCITT Recommendation Q.71 [7]). CFU79 reconnects at the same point.
- NOTE 2: CFU80 and CFU81 break the basic call transition following the receipt of input signal "SETUP resp.conf" (see figure 2-9 (sheet 8 of 19) of CCITT Recommendation Q.71 [7]). CFU81 reconnects at the same point.
- NOTE 3: CFU82 and CFU83 break the basic call transition following the receipt of input signal "REPORT (alerting) req.ind" (see figure 2-9 (sheet 14 of 19) of CCITT Recommendation Q.71 [7]). CFU83 reconnects at the same point.
- NOTE 4: CFU84 and CFU85 break the basic call transition following the receipt of input signal "SETUP resp.conf" (see figure 2-9 (sheet 15 of 19) of CCITT Recommendation Q.71 [7]). CFU85 reconnects at the same point.
- NOTE 5: CFU86 and CFU87 break the basic call transition following the receipt of input signal "SETUP resp.conf" (see figure 2-9 (sheet 16 of 19) of CCITT Recommendation Q.71 [7]). CFU87 reconnects at the same point.

8.7 FE8

The SDL diagram for FE8 is shown in figure 17.

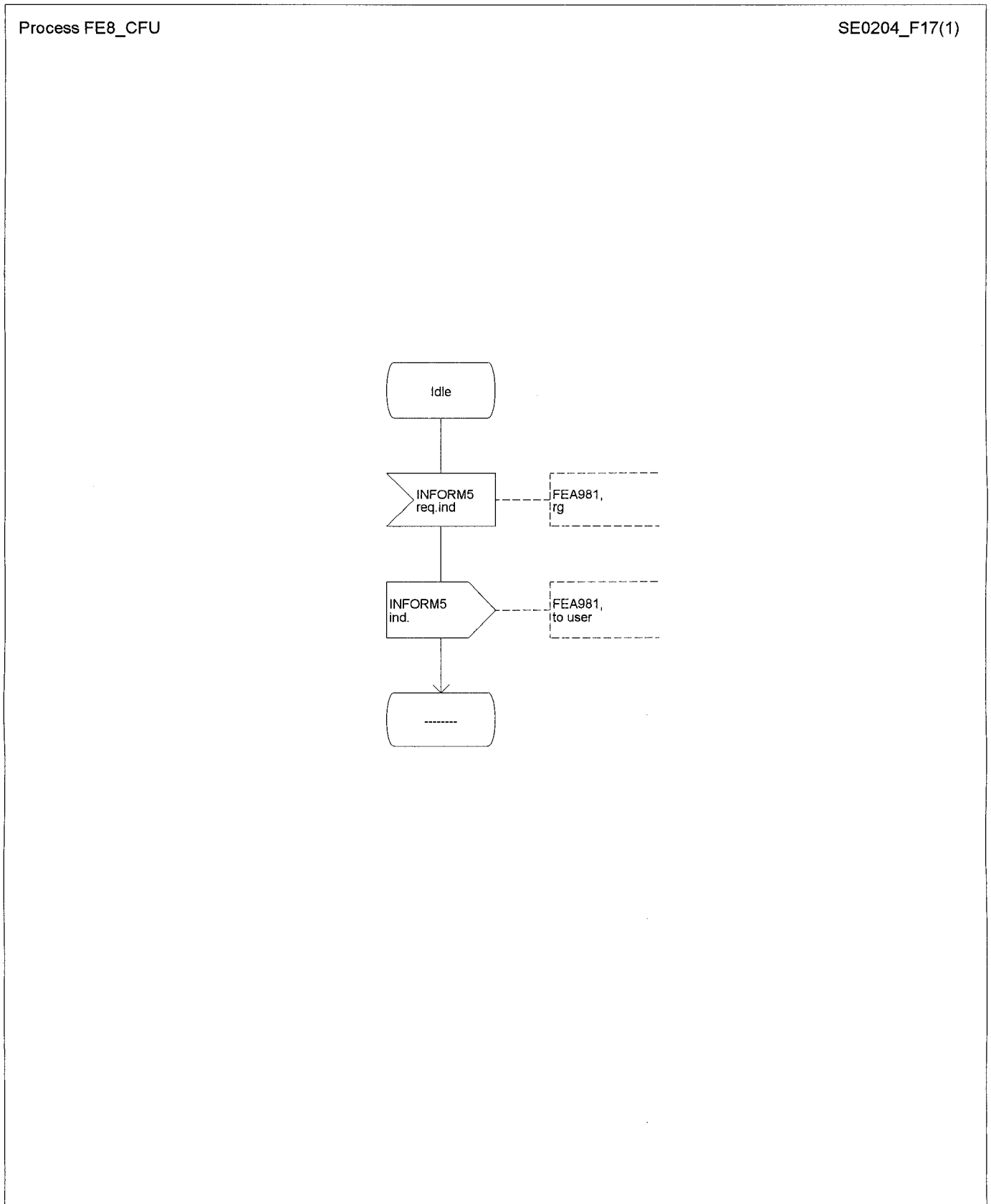

Figure 17

9 Functional Entity Actions (FEAs)

9.1 FEAs of FE1

911: Receive indications related to the service from FE2 and present them to the calling user.

9.2 FEAs of FE2

921: Receive INFORM1 req.ind, delete old FTN if already saved, save new FTN (when available), save NSO if it is the first or a subsequent more restrictive NSO.

922: Send INFORM2 req.ind to FE1 if allowed.

923: Receive INFORM6 req.ind and send INFORM7 req.ind to FE1 if allowed.

9.3 FEAs of FE3

931: Send INFORM1 req.ind to FE2.

932: Receive INFORM10 req.ind (forwarding request) including all necessary parameters from FE4.

933: Stimulate release procedures for the leg towards the served user.

934: Stimulate basic call set-up towards the forwarded-to user.

935: Decide whether forwarding is allowed and valid.

936: Insert stored parameters (FEA 93A and FEA 932) into SETUP req.ind and INFORM4 req.ind and send INFORM4 req.ind with all necessary information to FE6.

938: Send INFORM10 resp.conf (result of forwarding request) to FE4.

930: Receive INFORM6 req.ind from FE6 and send it to FE2.

93A: Receive indication of SETUP req.ind from basic call and store calling party number and restriction indicator.

9.4 FEAs of FE4

943: Receive INFORM10 resp.conf and determine the success or failure of the forwarding request.

945: Validation of call forwarding request.

946: Increment forwarding counter and determine whether the call count limit is exceeded.

948: Determine parameters for INFORM10 req.ind and send INFORM10 req.ind to FE3.

949: Stimulate release procedure with the reason "supplementary service incompatibility".

- 940: Recognize CFU supplementary service invoked from basic call and retrieve necessary parameters in case of multiple forwarding.
- 94A: Send INFORM3 req.ind to FE5 if required.
- 94E: Decrement forwarding counter.

9.5 FEAs of FE5

- 951: Receive indications related to the served user from FE4 and present them to the served user.

9.6 FEAs of FE6

- 961: Send INFORM6 req.ind to FE3.

NOTE: This FEA is only required when the PI is determined in FE6.

- 963: Receive INFORM4 req.ind from FE3, store:
- last forwarding number + restriction indicators;
- originally called number + restriction indicator.
- 964: Send INFORM4 req.ind to FE7, restrict, if required, originally called number and/or last forwarding number.
- 965: Receive indication from the basic call of receipt of REPORT (alerting) req.ind or SETUP resp.conf and determine PI by interaction between the basic service, the CFU supplementary service and the COLR supplementary service.
- 966: Relay any received INFORM6 req.ind.
- 967: Pass stored parameters to new FE3 (internal) when multiple forwarding occurs (not fully described in the SDL diagrams).

9.7 FEAs of FE7

- 971: Send INFORM6 req.ind to FE6.
- 972: Save forwarding parameters for use in next FE4 (internal) when multiple forwardings apply (not described in the SDL diagrams).
- 973: Receive INFORM4 req.ind from FE6.
- 974: Send INFORM5 req.ind to FE8.
- 975: Receive indication from the basic call of receipt of REPORT (alerting) req.ind or SETUP resp.conf and determine PI by interaction between the basic service, the CFU supplementary service and the COLR supplementary service.

9.8 FEAs of FE8

- 981: Receive indications related to the service from FE7 and present them to the called user.

10 Allocation of FEs to physical locations

The possible physical locations of FEs are shown in table 12.

Table 12: Scenarios for the CFU supplementary service

Scenario	A Party		B Party			C Party		
	FE1	FE2	FE3	FE4	FE5	FE6	FE7	FE8
1	TE	LE	LE		TE	LE		TE
2	PTNX	LE	LE		TE	LE		TE
3	TE	LE	PTNX		TE	LE		TE
4	TE	LE	LE		TE	LE	PTNX	TE
5	PTNX	LE	LE		TE	LE	PTNX	TE
6	TE	LE	PTNX		TE	LE	PTNX	TE
7 (note 2)	TE	LE	LE		PTNX	LE		TE
8 (note 2)	TE	LE	LE		PTNX	LE	PTNX	TE
9 (note 3)	TE	LE	LE	PTNX	TE	LE		TE
10 (note 3)	PTNX	LE	LE	PTNX	TE	LE		TE
11 (note 3)	TE	LE	LE	PTNX	TE	LE	PTNX	TE
12 (note 3)	PTNX	LE	LE	PTNX	TE	LE	PTNX	TE
NOTE 1:	The network provider may limit the number of calls simultaneously diverted from a particular access.							
NOTE 2:	All calls to the Public Telecommunication Network Exchange (PTNX) FE5 are diverted to the same FTN.							
NOTE 3:	The provision of partial rerouteing is a public network provider option. In networks which provide partial rerouteing, Private Telecommunications Network Exchange (PTNXs) may operate scenarios 9, 10, 11 and 12.							

Annex A (informative): Explanatory model for multiple diversion

Figure A.1 contains an explanatory model for multiple diversions in the case of call forwarding by forward switching.

In figure A.1 the functional model is mapped on a model for a basic call. When the call forwarding supplementary service is implemented by forward switching, FE3 and FE4 are always collocated at the same Call Control (CC).

The different hops of a call encountering several diversions are linked at the level of the basic call.

In the nodes (CCs) where new hops occur, both the FE6 of the last hop and FE3 of the new hop need to be collocated.

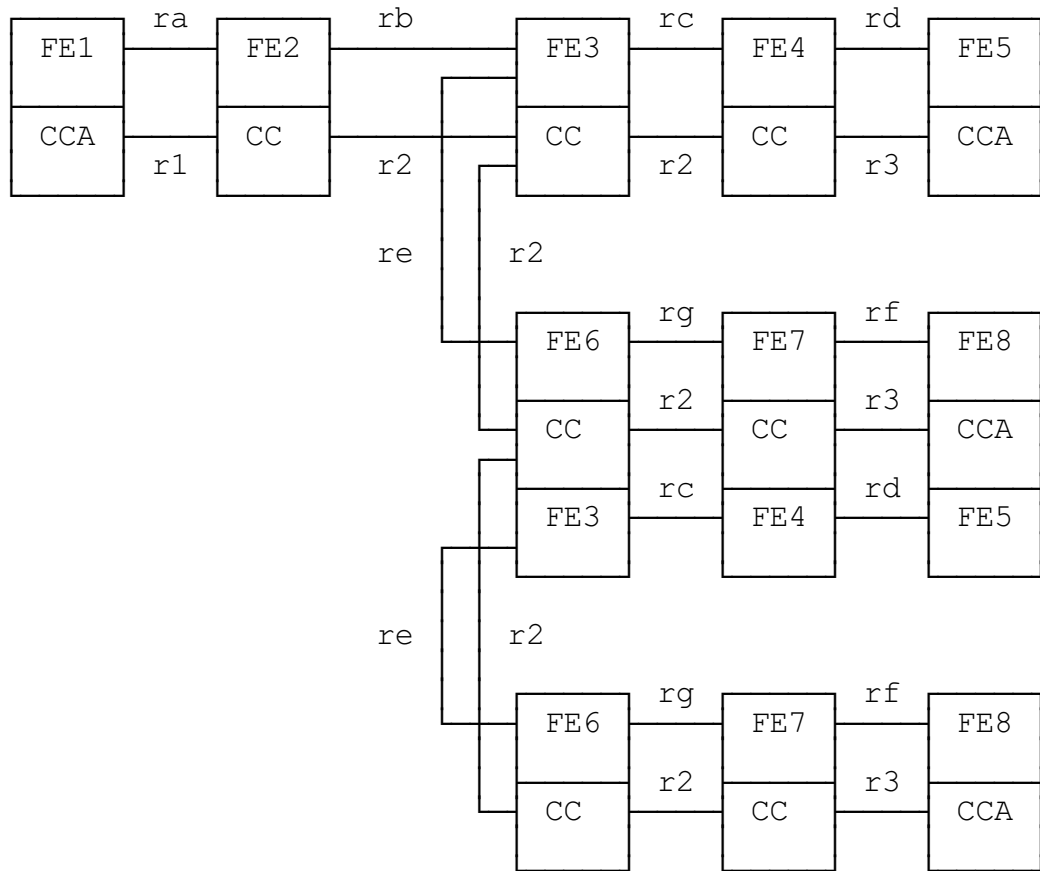

Figure A.1: Explanatory model for multiple diversion

Annex B (normative): Activation, deactivation, registration and interrogation

B.1 Definitions

The following additional definitions apply:

Supplementary Service Control (SSC): the SSC is responsible for the activation, deactivation and interrogation of the supplementary service. The SSC consists of the following SCEs:

SCE1, service controller's agent: This entity provides the functionality enabling the controller to activate and deactivate the supplementary service;

SCE2, profile control and service: This entity acts under the instructions from SCE1, making modifications to the global data associated with the Service Profile. It also supplies information to SCE3 about changes to the service, and responds to interrogation requests from SCE3;

SCE3, service user's agent: This entity provides the functionality enabling the user to interrogate the supplementary service, and receives notification of changes to the service.

global data: This is data which is available to the Service Profile process in order for it to determine the states of the controlled supplementary service, and service specific details such as the FTN. The global data can be modified only via SCE2.

B.2 Description

To activate call forwarding, the served user shall supply:

- the FTN, which may be accompanied by a forwarded-to subaddress;
- information as to whether all calls or all calls of a specified basic service should be forwarded;
- possibly the ISDN number for which call forwarding should apply (e.g. multiple subscriber number).

Deactivation is possible in either of two ways:

- the user can specifically deactivate the call forwarding activation, whereupon the network shall discard the FTN;
- the user can activate call forwarding for the specified basic service to another number, thus causing the previous invocation of call forwarding to be overridden.

Interrogation should be possible by means of an appropriate request. The network response to such a request should provide the relevant information for the user.

B.3 Derivation of the functional model

B.3.1 Functional model description

The functional model is shown in figure B.1.

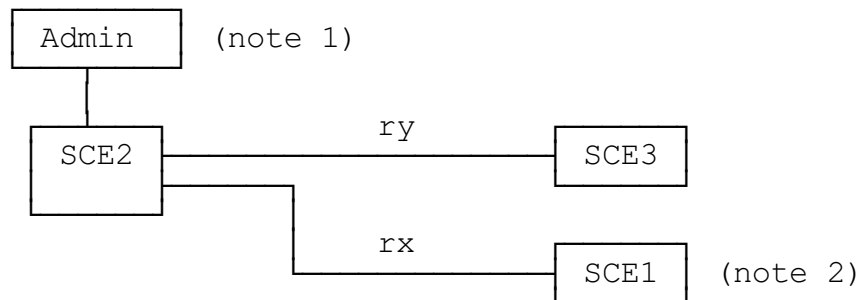

NOTE 1: Outside the scope of this ETS.

NOTE 2: SCE1 provides only the additional functionality required to activate and deactivate the service. As a result every SCE1 shall have an associated SCE3, although SCE3 can stand alone.

Figure B.1: Functional model

B.3.2 Description of the FEs

The FEs required for activation, deactivation, registration and interrogation above those of the basic call are as follows:

- SCE1: service controller's agent;
- SCE2: profile control and service;
- SCE3: service user's agent.

B.3.3 Relationship with a basic service

The relationship with a basic service is shown in figure B.2.

NOTE: The basic call model is defined in CCITT Recommendation Q.71 [7], § 2.1, with the exception that r1 represents an outgoing call relationship from a CCA and r3 represents an incoming call relationship to a CCA.

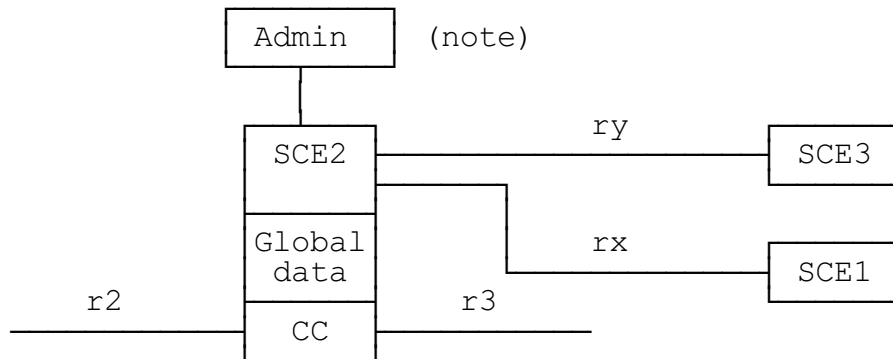

NOTE: Outside the scope of this ETS.

Figure B.2: Relationship with a basic service

B.3.4 Relationship of the user's Service Control Model (SCM) to the CFU supplementary service FE model

The relationship of the user's SCM to the call forwarding functional model is shown in figure B.3.

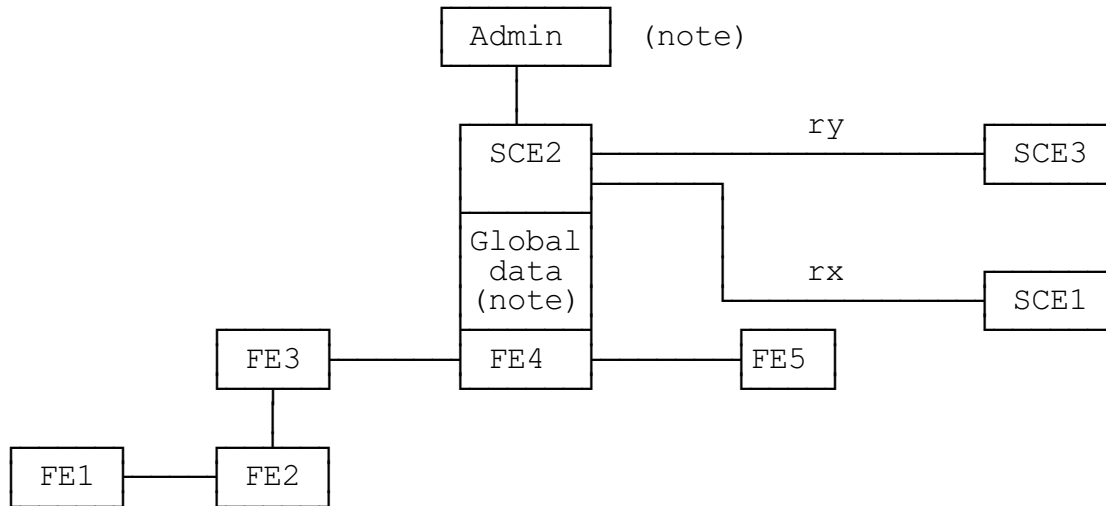

NOTE: Outside the scope of this ETS.

Figure B.3: Relationship to functional model

B.4 Information flows

B.4.1 Information flow diagram for the SSC

Figure B.4 shows the information flows for the SSC.

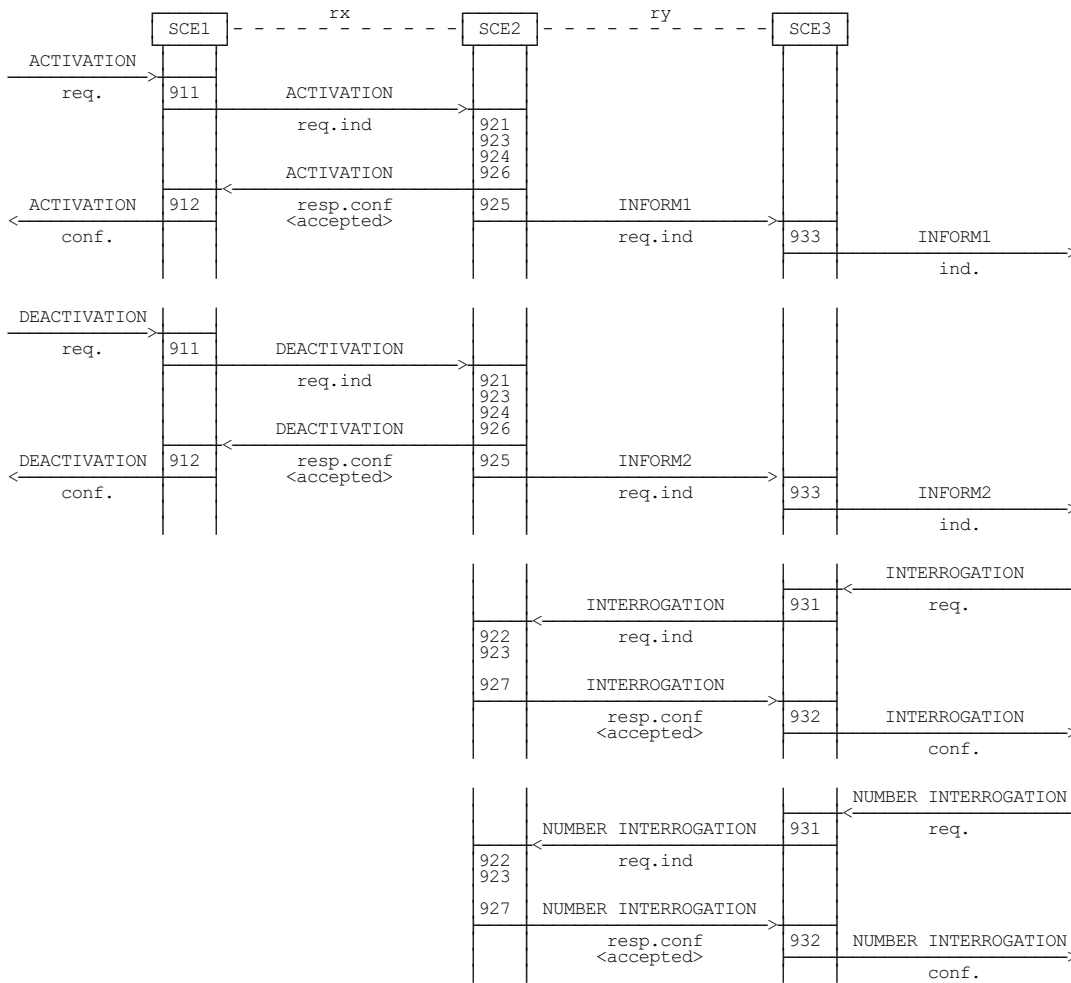

Figure B.4: Information flow

B.4.2 Definition of individual information flows**B.4.2.1 Relationship rx****B.4.2.1.1 Contents of ACTIVATION**

The content of ACTIVATION is shown in table B.1.

Table B.1

Parameter	Allowed value	req.ind	resp.conf
forwarding required basic service for forwarding	CFU - identified service - all services	M M (note 1)	
forwarded-to address forwarding number	- identified number - all	M M (note 2)	
activation result	positive/negative acknowledgement		M
reason for rejection	(note 3)		O
NOTE 1:	This parameter is ignored by SCE2 if forwarding is not provided for each basic service. A basic service need not be identified if forwarding is only subscribed for one basic service.		
NOTE 2:	This parameter is ignored by SCE2 if forwarding is not provided on a per number basis, or if forwarding is provided on a per number basis but the multiple subscriber number service is not supported/subscribed.		
NOTE 3:	Possible reasons are: "service not subscribed", "service not available", "service not implemented", "resource unavailable", "invalid FTN", "FTN is operator access", "FTN is special service ISDN number", "FTN is served user's ISDN number", "basic service not provided", "invalid served user number".		

B.4.2.1.2 Contents of DEACTIVATION

The content of DEACTIVATION is shown in table B.2.

Table B.2

Parameter	Allowed value	req.ind	resp.conf
forwarding required basic service for forwarding	CFU - identified service - all services	M M (note 1)	
forwarding number	- identified number - all	M (note 2)	
deactivation result	positive/negative acknowledgement		M
reason for rejection	(note 3)		O
NOTE 1: This parameter is ignored by SCE2 if forwarding is not provided for each basic service. A basic service need not be identified if forwarding is only subscribed for one basic service.			
NOTE 2: This parameter is ignored by SCE2 if forwarding is not provided on a per number basis, or if forwarding is provided on a per number basis but the multiple subscriber number service is not supported/subscribed.			
NOTE 3: Possible reasons are: "service not subscribed", "service not available", "invalid served user number", "not activated".			

B.4.2.2 Relationship ry

B.4.2.2.1 Contents of INFORM1

The content of INFORM1 is shown in table B.3.

Table B.3

Parameter	Allowed value	req.ind
forwarding type basic service for forwarding	CFU - identified service - all services	M M
forwarded-to address forwarding number	- identified number - all	M M

B.4.2.2.2 Contents of INFORM2

The content of INFORM2 is shown in table B.4.

Table B.4

Parameter	Allowed value	req.ind
forwarding type	CFU	M
basic service for forwarding	- identified service	M
	- all services	
forwarding number	- identified number	M
	- all	

B.4.2.2.3 Contents of INTERROGATION

The content of INTERROGATION is shown in table B.5.

Table B.5

Parameter	Allowed value	req.ind	resp.conf
forwarding required	CFU	M	
basic service for forwarding	- identified service	M	
	- all services		
forwarding number	- identified number	M	
	- all		
interrogation result	positive/negative acknowledgement		M
forwarding list for each forwarding			
- forwarding type	CFU		O (note 1)
- basic service for forwarding	- identified service		O (note 1)
	- all services		
- forwarded-to address			O (note 1)
- forwarding number	- identified number		O (note 1)
	- all		
reason for rejection	(note 2)		O
NOTE 1: If the interrogation result is positive, then all parameters shall be included.			
NOTE 2: Possible reasons are: "service not subscribed", "service not available", "service not implemented", "invalid served user number".			

B.4.2.2.4 Contents of NUMBER INTERROGATION

The content of NUMBER INTERROGATION is shown in table B.6.

Table B.6

Parameter	Allowed value	req.ind	resp.conf
interrogation result	positive/negative acknowledgement		M
forwarding list for each forwarding - forwarding number reason for rejection	identified number (note)		O O
NOTE: Possible reasons are: "service not subscribed", "service not available", "service not implemented".			

B.5 SDL diagrams for SCEs

The SDL diagrams are provided according to CCITT Recommendation Z.100 [8].

B.5.1 SCE1

The SDL diagram for SCE1 is shown in figure B.5.

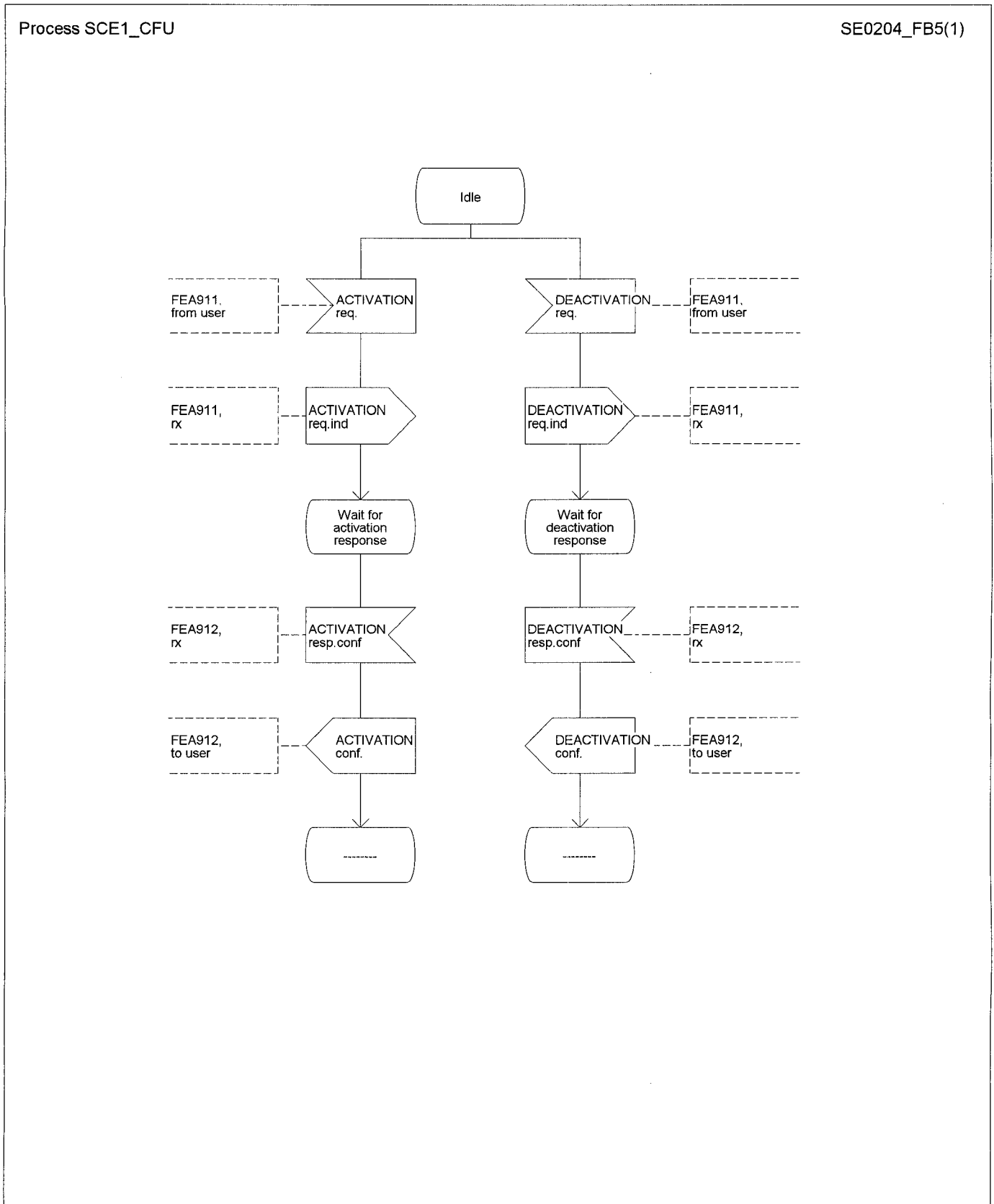

Figure B.5

B.5.2 SCE2

The SDL diagram for SCE2 is shown in figure B.6.

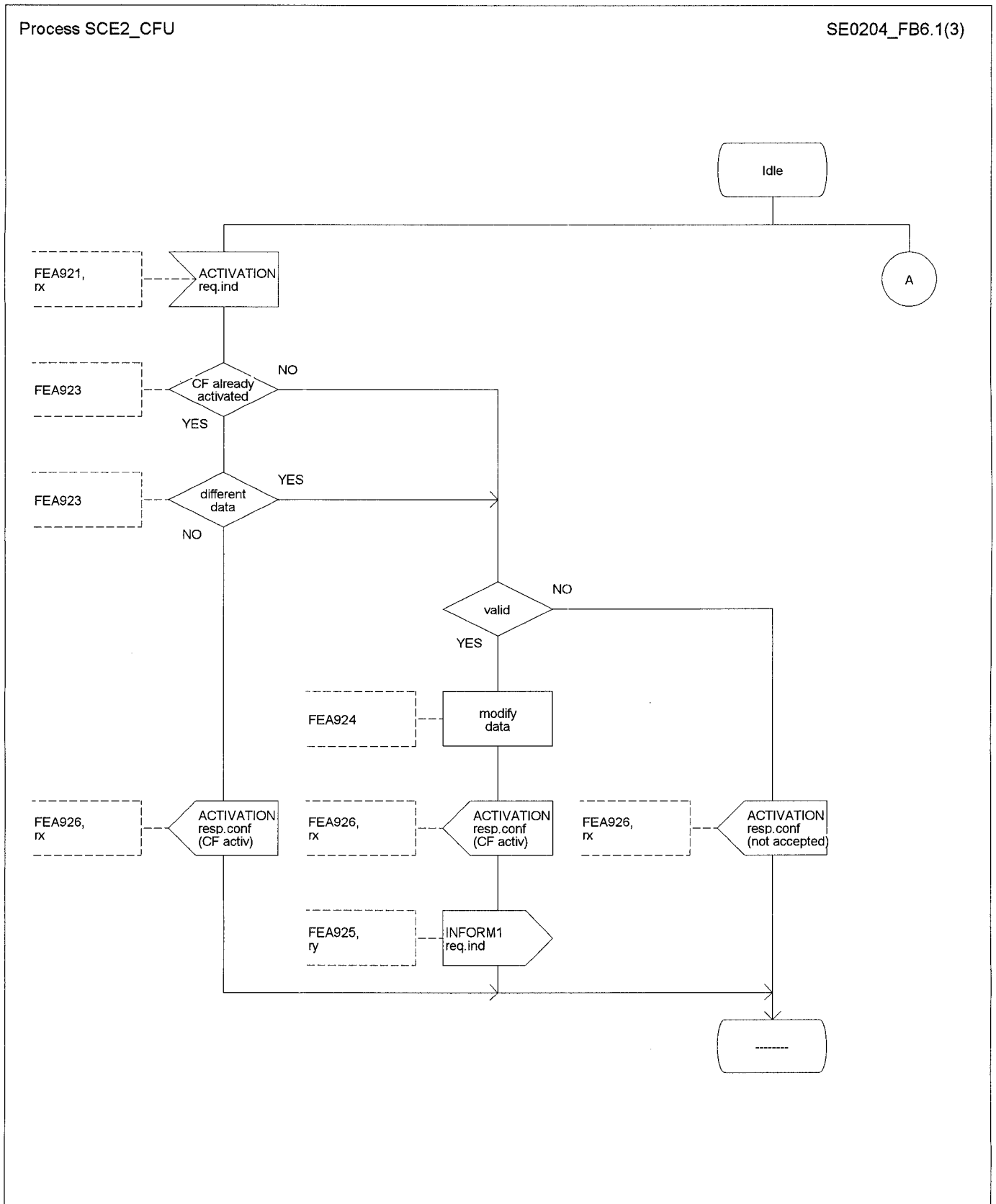

Figure B.6 (sheet 1 of 3)

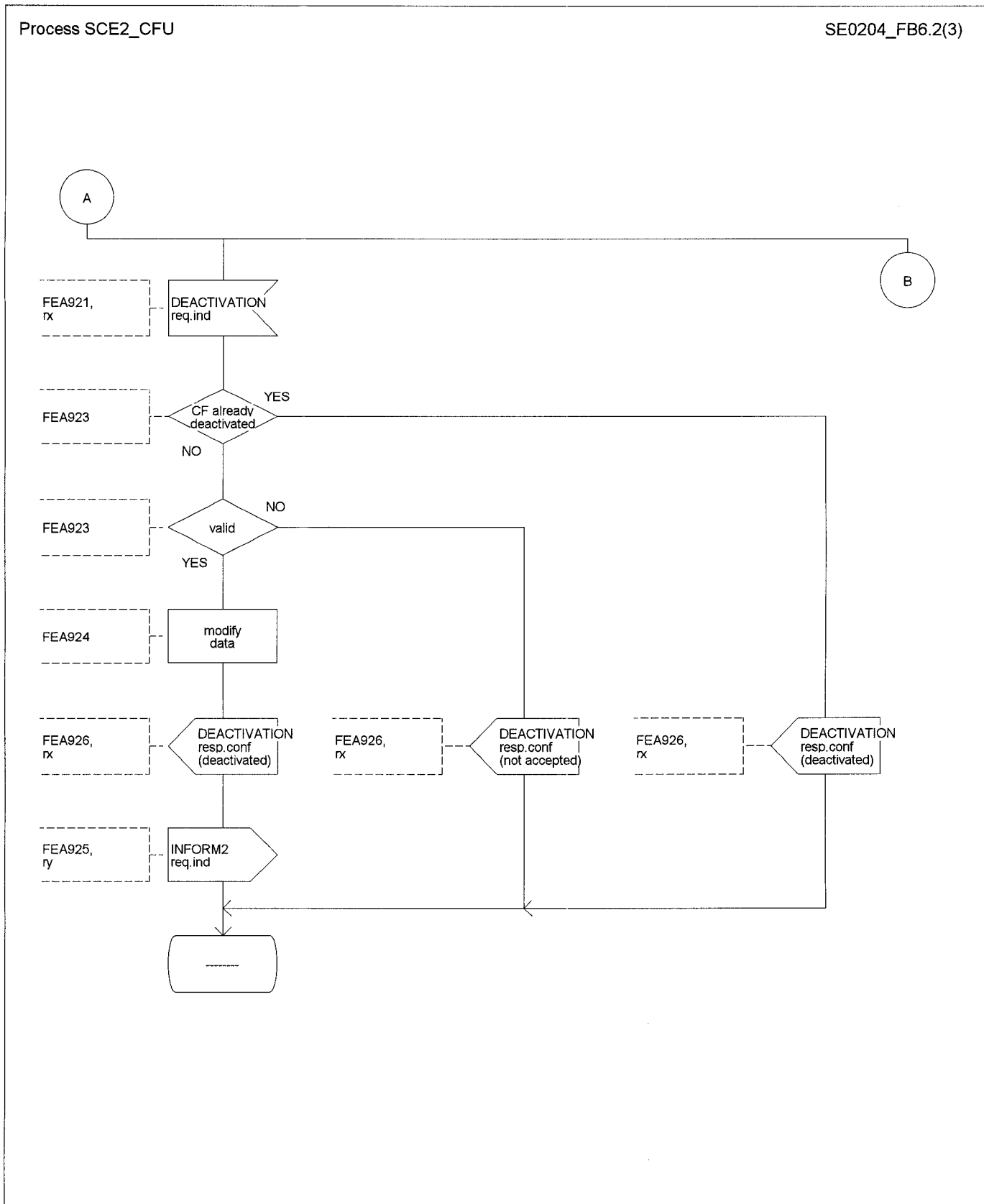

Figure B.6 (sheet 2 of 3)

Process SCE2_CFU

SE0204_FB6.3(3)

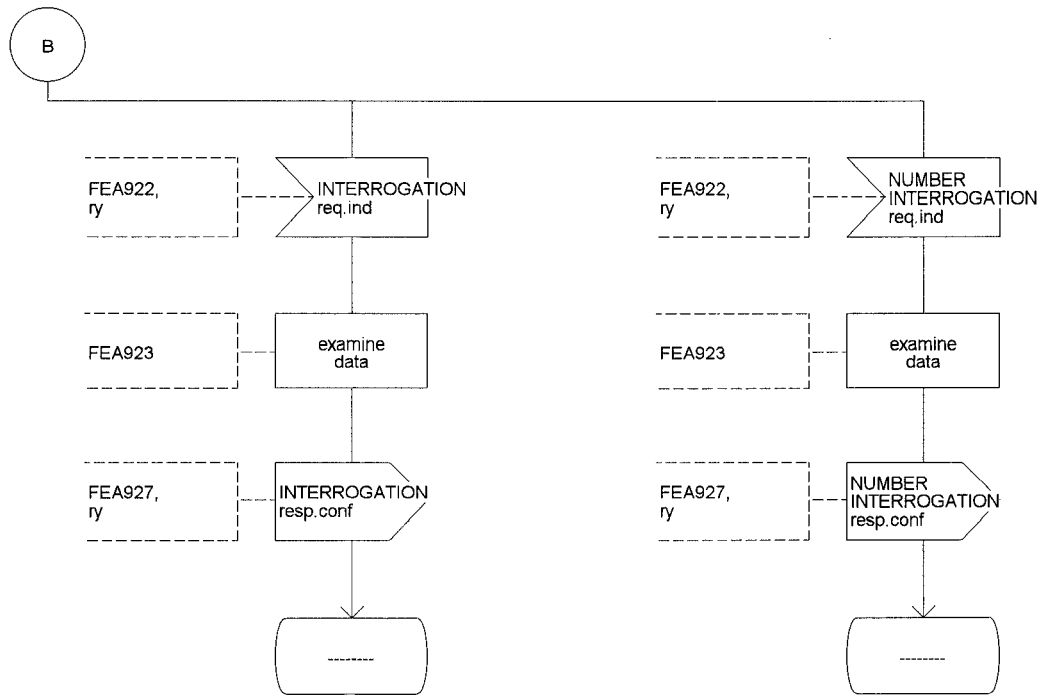

Figure B.6 (sheet 3 of 3)

B.5.3 SCE3

The SDL diagram for SCE3 is shown in figure B.7.

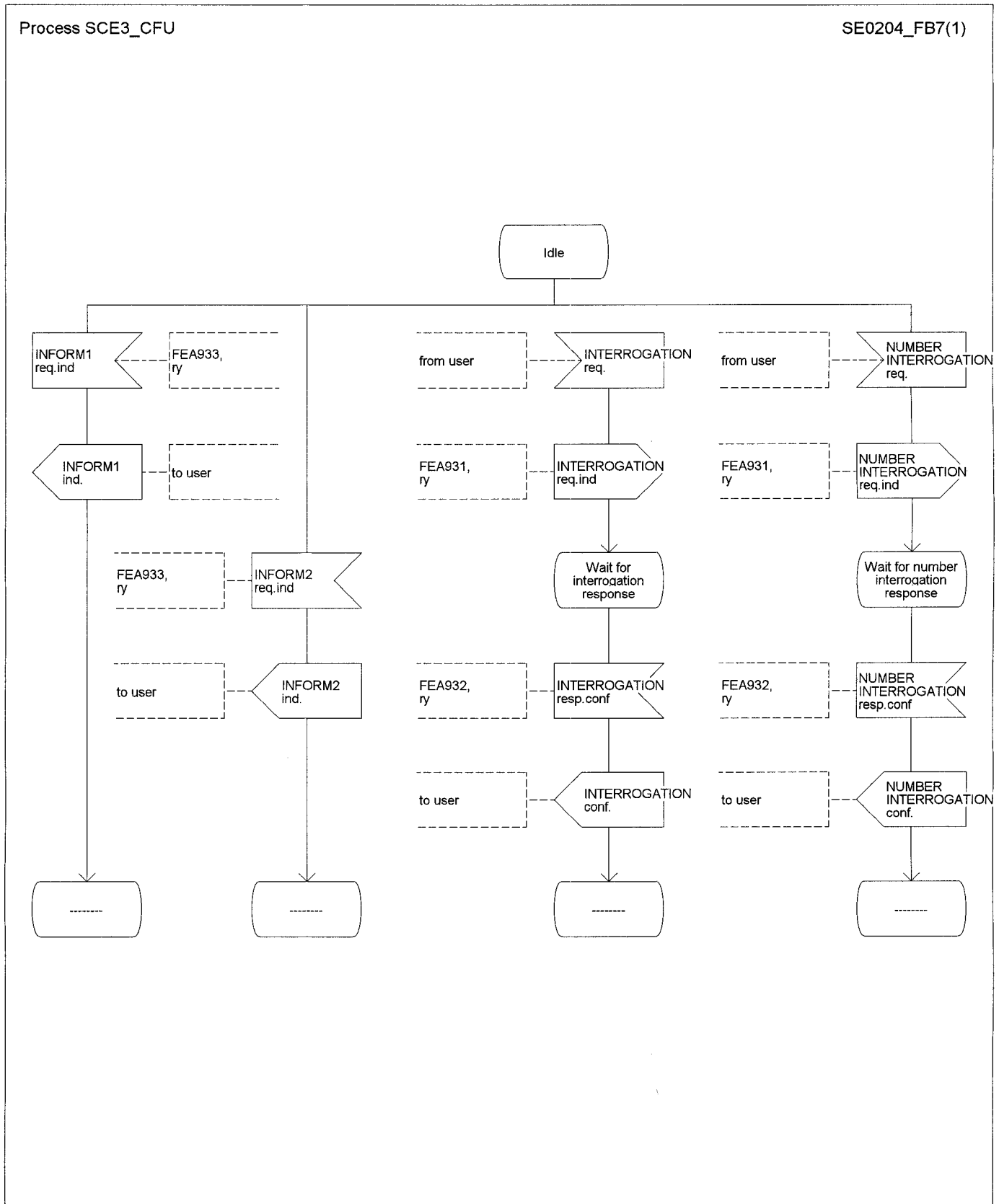

Figure B.7

B.6 SCE actions

B.6.1 SCE1

911: Formulate and forward activation and deactivation requests received from the controller to SCE2.

912: Receive responses relating to the success or failure of the requested action.

B.6.2 SCE2

921: Receive requests for activation and deactivation from SCE1.

922: Receive requests for interrogation from SCE3.

923: Validate requests on the basis of correct information content and user authority.

924: Update relevant global data on receipts on valid activation and deactivation requests.

925: Inform all SCE3s of successful modifications to services.

926: Inform the requesting SCE of the success or failure of requests.

927: Respond to valid requests for interrogation from SCE3 by formulating the response and forwarding it to the requesting SCE3.

B.6.3 SCE3

931: Formulate and forward interrogation received from the user to SCE2.

932: Receive responses to interrogation requests.

933: Receive notification from SCE2 of successful activations and deactivations made by any SCE1.

B.7 Allocation of SCEs to physical locations

The possible physical locations of SCEs are shown in table B.7.

Table B.7

Scenarios	B Party		
	SCE1	SCE2	SCE3
1	TE	LE	TE
2	TE	PTNX	TE
3	PTNX	LE	PTNX

History

Document history	
December 1994	First Edition
May 1996	Converted into Adobe Acrobat Portable Document Format (PDF)