



EUROPEAN
TELECOMMUNICATION
STANDARD

FINAL DRAFT
pr **ETS 300 176-1**

August 1996

Second Edition

Source: ETSI TC-RES

Reference: RE/RES-03028-1

ICS: 33.020, 33.060.50

Key words: DECT, radio, testing, type approval

**Radio Equipment and Systems (RES);
Digital Enhanced Cordless Telecommunications (DECT);
Approval test specification;
Part 1: Radio**

ETSI

European Telecommunications Standards Institute

ETSI Secretariat

Postal address: F-06921 Sophia Antipolis CEDEX - FRANCE

Office address: 650 Route des Lucioles - Sophia Antipolis - Valbonne - FRANCE

X.400: c=fr, a=atlas, p=etsi, s=secretariat - **Internet:** secretariat@etsi.fr

Tel.: +33 92 94 42 00 - Fax: +33 93 65 47 16

Copyright Notification: No part may be reproduced except as authorized by written permission. The copyright and the foregoing restriction extend to reproduction in all media.

© European Telecommunications Standards Institute 1996. All rights reserved.

Contents

Foreword	9
1 Scope	11
2 Normative references	12
3 Definitions and abbreviations	13
3.1 Definitions	13
3.2 Abbreviations	15
4 General	16
4.1 Document layout	16
4.1.1 Test suites	16
4.1.2 Test groups	16
4.1.3 Test cases	17
4.2 Presentation of equipment for testing purposes	17
4.2.1 Choice of model for type examination	17
4.2.2 Description of equipment	18
4.2.2.1 Protocol Implementation Conformance Statement (PICS) ..	18
4.2.2.2 Protocol Implementation eXtra Information for Testing (PIXIT)	18
4.2.2.3 Environmental test conditions	18
4.2.3 Host connected equipment	18
4.2.4 Applicant's declaration	18
4.3 Applicability of type tests	18
4.3.1 Equipment that includes only a DECT RF receiver	18
4.3.2 Equipment that includes a radio transmitter	19
4.3.3 Equipment that is equipped with an analogue port	19
4.3.4 Equipment with a synchronization port	19
4.3.5 Equipment incorporating the IPEI (PPs only)	19
4.3.6 All FP equipment	19
4.3.7 PPs with direct PP to PP communication option	19
4.3.8 Installation related issues	19
4.3.9 Wireless relay stations	19
4.4 Interpretation of the measurement results	20
5 General test requirements	20
5.1 Test philosophy	20
5.2 Test site	21
5.2.1 Open air test site	21
5.2.1.1 Description	21
5.2.1.2 Calibration	22
5.2.2 Anechoic chamber	23
5.2.2.1 General	23
5.2.2.2 Description	23
5.2.2.3 Influence of parasitic reflections	25
5.2.2.4 Calibration and mode of use	25
5.2.3 Stripline coupler	25
5.2.3.1 Description	25
5.2.3.2 Calibration	25
5.2.3.3 Mode of use	26
5.3 Standard position	26
5.4 Test antenna of the LT	26
5.5 Substitution antenna	26
5.6 Test fixture	27
5.6.1 Description	27
5.6.1.1 Calibration of the test fixture for the measurement of transmitter characteristics	27

	5.6.1.2	Calibration of the test fixture for the measurement of receiver characteristics	28
	5.6.1.3	Mode of use	28
	5.6.2	Equipment with a temporary or internal permanent antenna connector	29
	5.6.2.1	Equipment with a temporary antenna connector	29
5.7		Indoor test site	29
	5.7.1	Description	29
	5.7.2	Test for parasitic reflections	30
	5.7.3	Calibration and mode of use	30
5.8		Lower Tester (LT)	31
	5.8.1	Description	31
	5.8.2	Connections between the EUT and the LT	31
	5.8.3	Functions and abilities	32
	5.8.4	Signal generation uncertainty	32
	5.8.4.1	Modulated DECT-like carrier	32
	5.8.4.2	CW interferers	32
	5.8.4.3	DECT RF Signal	32
	5.8.4.4	Test modulation signals	32
	5.8.5	Measurement uncertainty	33
5.9		Upper Tester (UT)	33
	5.9.1	Description of the UT	33
	5.9.2	The test standby mode	33
	5.9.3	Test messages	34
5.10		Description of the lower tester FT and PT	34
5.11		General test methods	34
	5.11.1	General	34
	5.11.2	Sampling the RF signal	35
	5.11.2.1	Introduction	35
	5.11.2.2	Sampling method	35
	5.11.3	Determining the reference position	35
	5.11.3.1	Case 1: EUTs that cannot transmit	35
	5.11.3.2	Case 2: EUTs that can transmit	35
	5.11.4	Bit error rate (BER) measurements	35
5.12		Test set-up	36
	5.12.1	Test set-up 1	36
	5.12.2	Test set-up 2	36
	5.12.3	Test set-up 3	37
	5.12.4	Test set-up 4	37
	5.12.5	Test set-up 5	38
5.13		Test arrangements for intermodulation measurements	38
	5.13.1	PT to PT arrangement	38
	5.13.2	FT to FT arrangement	39
	5.13.3	FT to PT arrangement	39
6		Test conditions, power sources and ambient temperatures	40
	6.1	General	40
	6.2	Nominal test conditions	40
	6.3	Extreme test conditions	41
	6.4	Test power source - general requirements	42
	6.5	Nominal test power source	42
	6.5.1	Mains voltage	42
	6.5.2	Regulated lead acid battery power sources	42
	6.5.3	Nickel cadmium battery	42
	6.5.4	Other power sources	42
	6.6	Extreme test power source	42
	6.6.1	Mains voltage	42
	6.6.2	Regulated lead acid battery power sources	42
	6.6.3	Nickel cadmium battery	42
	6.6.4	Other power sources	43
	6.7	Testing of host connected equipment and plug-in cards	43
	6.7.1	Alternative A: composite equipment	43
	6.7.2	Alternative B: use of a test jig and three hosts	43

7	Accuracy and stability of RF carriers.....	44
7.1	Definition	44
7.2	Test environment	44
7.3	Method of measurement.....	44
7.4	Verdict criteria when the EUT is a RFP	45
7.5	Verdict criteria when the EUT is a PP.....	45
	7.5.1 Case 1: When the measurement is made during the first 1 s of the EUT going into a transmit mode from a non-transmitting mode.....	45
	7.5.2 Case 2: When the measurement is made at any other time.....	45
8	Accuracy and stability of timing parameters.....	45
8.1	Slot structure definitions.....	45
8.2	Definition of the position of p0.....	46
8.3	Measurement of packet timing jitter.....	46
	8.3.1 Test environment.....	46
	8.3.2 Method of measurement	47
	8.3.3 Verdict criteria	47
8.4	Measurement of the reference timing accuracy of a RFP	47
	8.4.1 Test environment.....	47
	8.4.2 Method of measurement	47
	8.4.3 Verdict criteria	48
8.5	Measurement of packet transmission accuracy of a PP.....	48
	8.5.1 Test environment.....	48
	8.5.2 Method of measurement	48
	8.5.3 Verdict criteria	49
9	Transmission burst.....	49
9.1	Definitions	49
	9.1.1 Physical packets.....	49
	9.1.2 Transmitted power.....	49
	9.1.3 Normal Transmitted Power (NTP).....	49
	9.1.4 Transmitter attack time.....	49
	9.1.5 Transmitter release time	49
	9.1.6 Minimum power.....	50
	9.1.7 Maximum power.....	50
	9.1.8 Maintenance of transmission after packet end.....	50
	9.1.9 Transmitter idle power output.....	50
9.2	Test environment	50
9.3	Method of measurement.....	50
9.4	Verdict criteria	51
10	Transmitted power	51
10.1	Definitions	51
	10.1.1 PP and RFP with an integral antenna	51
	10.1.2 PP and RFP with external connections for all antennas	51
	10.1.3 PP and RFP with both integral and external antennas.....	52
10.2	PP and RFP with an integral antenna.....	52
	10.2.1 Test environment.....	52
	10.2.2 Method of measurement	52
	10.2.2.1 Measurement of NTP	52
	10.2.2.2 Measurement of antenna gain.....	53
	10.2.3 Verdict criteria for all EUTs.....	53
10.3	PP and RFP with external antenna connection(s)	54
	10.3.1 Test environment.....	54
	10.3.2 Method of measurement	54
	10.3.3 Verdict criteria for all EUTs.....	54
11	RF carrier modulation.....	54
11.1	Test environment	54
11.2	Method of measurement, Parts 1 and 2	55
	11.2.1 Part 1	55
	11.2.2 Part 2.....	55
11.3	Method of measurement, Parts 3 and 4	56

	11.3.1	Part 3	56
	11.3.2	Part 4	56
11.4		Verdict criteria for Part 1	56
11.5		Verdict criteria for Part 2	56
11.6		Verdict criteria for Part 3	57
11.7		Verdict criteria for Part 4	57
12		Unwanted RF power radiation	58
12.1		General test conditions.....	58
12.2		Emissions due to modulation	58
	12.2.1	Definition.....	58
	12.2.2	Test environment.....	58
	12.2.3	Method of measurement.....	58
	12.2.4	Verdict criteria.....	59
12.3		Emissions due to transmitter transients	60
	12.3.1	Definition.....	60
	12.3.2	Test environment.....	60
	12.3.3	Method of measurement.....	60
	12.3.4	Verdict criteria.....	61
12.4		Emissions due to intermodulation	61
	12.4.1	Definition.....	61
	12.4.2	Test environment.....	61
	12.4.3	Method of measurement.....	61
	12.4.4	Verdict criteria.....	62
12.5		Spurious emissions when allocated a transmit channel.....	62
	12.5.1	Definition.....	62
	12.5.2	Radiated emissions	63
		12.5.2.1 Test environment	63
		12.5.2.2 Method of measurement.....	63
		12.5.2.3 Verdict criteria	64
	12.5.3	Conducted spurious emissions.....	64
		12.5.3.1 Test environment	64
		12.5.3.2 Method of measurement.....	64
		12.5.3.3 Verdict criteria	65
13		Radio receiver testing	65
13.1		Radio receiver sensitivity.....	65
	13.1.1	Definition.....	65
	13.1.2	Test environment.....	65
	13.1.3	Method of measurement.....	65
	13.1.4	Verdict criteria.....	66
13.2		Radio receiver reference BER	66
	13.2.1	Definition.....	66
	13.2.2	Test environment.....	66
	13.2.3	Method of measurement.....	66
	13.2.4	Verdict criteria.....	66
13.3		Radio receiver interference performance.....	67
	13.3.1	Definition.....	67
	13.3.2	Test environment.....	67
	13.3.3	Method of measurement.....	67
	13.3.4	Verdict criteria.....	67
13.4		Radio receiver blocking case 1: owing to signals occurring at the same time but on other frequencies	68
	13.4.1	Definition.....	68
	13.4.2	Test environment.....	68
	13.4.3	Method of measurement.....	68
	13.4.4	Verdict criteria.....	69
13.5		Radio receiver blocking case 2: owing to signals occurring at a different time.....	69
	13.5.1	Definition.....	69
	13.5.2	Test environment.....	69
	13.5.3	Method of measurement.....	70
	13.5.4	Verdict criteria.....	70
13.6		Receiver intermodulation performance	70

13.6.1	Definition	70
13.6.2	Test environment.....	70
13.6.3	Method of measurement	71
13.6.4	Verdict criteria	71
13.7	Spurious emissions when the PP has no allocated transmit channel.....	71
13.7.1	Definition	71
13.7.2	Test environment.....	71
13.7.3	Method of measurement	72
13.7.4	Verdict criteria (outside the DECT band).....	72
13.7.5	Verdict criteria (inside the DECT band).....	72
14	Synchronization port (FP only)	72
14.1	Description	72
14.2	Test environment	73
14.3	FP as a master	73
14.3.1	Method of measurement	73
14.3.2	Verdict criteria	73
14.4	FP as a slave	74
14.4.1	Method of measurement	74
14.4.2	Verdict criteria	74
14.5	FP with integrated Global Positioning System (GPS) synchronization	74
14.5.1	Method of measurement	74
14.5.2	Verdict criteria	75
14.6	External GPS synchronization device	75
14.6.1	Method of measurement	75
14.6.2	Verdict criteria	75
15	EMC	75
16	Equipment identity testing	76
16.1	PP	76
16.2	FP	76
17	Efficient use of the radio spectrum.....	76
17.1	Channel selection	76
17.2	Channel confirmation.....	76
17.2.1	For the PT	76
17.2.2	For the FT.....	76
17.3	Channel release.....	77
17.4	General	77
Annex A (informative):	Bibliography.....	78
Annex B (normative):	Procedures for test fixture calibration and for measurement of radiated spurious emissions.....	79
B.1	Calibration of test fixture for receiver measurements	79
B.1.1	Method of measurement.....	79
B.2	Radiated measurements	81
B.2.1	General	81
B.2.2	Radiated spurious emissions.....	81
B.2.2.1	Definition	81
B.2.2.2	Method of measurement	82
B.2.3	Cabinet radiation.....	84
B.2.3.1	Definition	84
B.2.3.2	Method of measurement	84
Annex C (normative):	Procedure for measurement of conducted spurious emissions	85
C.1	Conducted spurious emissions	85
C.1.1	Definition	85
C.1.2	Method of measurement.....	85

Annex D (normative):	Test Support Profile (TSP).....	86
D.1	Introduction.....	86
D.2	Standardized symbols for the status column.....	86
D.3	Capabilities of PP (EUT) under test.....	87
D.3.1	Services.....	87
D.3.2	Messages.....	87
D.3.3	Message parameters.....	89
D.3.4	Procedure support.....	91
D.3.5	CSF multiplexing functions.....	92
D.3.6	Timer and counter support.....	92
D.4	Capabilities of FP (EUT) under test.....	93
D.4.1	Services.....	93
D.4.2	Messages.....	93
D.4.3	Message parameters.....	95
D.4.4	Procedure support.....	97
D.4.5	CSF multiplexing functions.....	98
D.4.6	Timer and counter support.....	98
Annex E (normative):	Measurement of BER.....	99
Annex F (informative):	Procedures for the measurement of synchronization loss at the EUT by the LT.....	100
F.1	Description.....	100
F.2	Method.....	100
Annex G (normative):	Requirements for PPs with direct PP to PP communication mode.....	101
G.1	Description of operation in direct PP to PP communication mode.....	101
G.2	Requirements.....	101
G.2.1	Setting the PP in direct communications mode.....	101
G.2.2	When the EUT has initiated a call.....	102
G.2.3	When the EUT has not initiated a call.....	102
Annex H (normative):	Requirements for installation related issues.....	103
H.1	Spectrum efficiency for speech transmission.....	103
H.2	Antennas with directivity.....	103
H.3	DECT frame synchronization.....	103
H.3.1	Guidance for installation of frame synchronized DECT systems.....	105
H.3.1.1	GPS synchronization.....	105
H.3.1.2	Wired synch port synchronization.....	105
H.3.1.3	Requirements for DECT air synchronization.....	105
Annex I (informative):	Essential requirements justification.....	106
Annex J (normative):	Additions to ETS 300 175-2.....	107
J.1	Additional text on GPS synchronization.....	107
History	111

Foreword

This final draft 2nd edition European Telecommunication Standard (ETS) has been produced by the Radio Equipment and Systems (RES) Technical Committee of the European Telecommunications Standards Institute (ETSI), and is now submitted for the Voting phase of the ETSI standards approval procedure.

This ETS contains text pertaining to approval testing of the Digital Enhanced Cordless Telecommunications (DECT) Common Interface. Such text should be considered as guidance to approval (or licensing) authorities.

Details of the DECT Common Interface may be found in ETS 300 175 parts 1 to 7 [1] to [7]. Further details of the DECT system may be found in the ETSI Technical Reports, ETR 015, ETR 043, and ETR 056 (see annex A).

This ETS consists of 2 parts as follows:

Part 1: "Radio";

Part 2: "Speech".

Proposed transposition dates	
Date of latest announcement of this ETS (doa):	3 months after ETSI publication
Date of latest publication of new National Standard or endorsement of this ETS (dop/e):	6 months after doa
Date of withdrawal of any conflicting National Standard (dow):	6 months after doa

Blank page

1 Scope

This European Telecommunications Standard (ETS) specifies the approval tests applicable to all Digital Enhanced Cordless Telecommunications (DECT) equipment accessing the DECT frequency band 1 880 MHz to 1 900 MHz (including provisions for testing other or extended frequency bands) and the approval tests applicable to DECT speech transmission using CCITT Recommendation G.726 [14] ADPCM speech codec at 32 kbit/s.

The aims of this ETS are to ensure:

- efficient use of frequency spectrum;
- no harm done to any connected network and its services;
- no harm done to other radio networks and services;
- no harm done to other DECT equipment or its services;
- interworking of terminal equipment via the public network,

through testing those provisions of ETS 300 175, parts 1 to 7 [1] to [7] which are relevant to these aims.

The tests of this ETS split into two parts:

- this part covers testing of radio frequency parameters, security elements and those DECT protocols that facilitate the radio frequency tests and efficient use of frequency spectrum;
- part 2 describes testing of DECT 32 kbit/s ADPCM speech requirements between network interface and DECT PT, or between a DECT CI air interface and alternatively a DECT PT or FT. Part 2 is not applicable to terminal equipment specially designed for the disabled (e.g. with amplification of received speech as an aid for the hard-of-hearing).

DECT comprises two equipment elements, referred to as a Fixed Part (FP) and a Portable Part (PP). Part 2 of this ETS is structured to allow type approval of either:

- a) the FP and PP together; or
- b) the FP and PP as separate items.

Where the DECT FP is connected to a PSTN, and there are any national peculiarities in the requirements for voice telephony, these shall be accommodated within the FP.

Additional tests apply for equipment implementing ETSI defined profiles (e.g. GAP, DECT-GSM, DECT-ISDN). These tests are found in related ETSs and may supersede the requirements of this ETS.

2 Normative references

This ETS incorporates, by dated or undated reference, provisions from other publications. These normative references are cited at the appropriate places in the text and the publications are listed hereafter. For dated references, subsequent amendments to, or revisions of any of these publications apply to this ETS only when incorporated in it by amendment or revision. For undated references the latest edition of the publication referred to applies.

- [1] prETS 300 175-1 (1996): "Radio Equipment and Systems (RES); Digital European Cordless Telecommunications (DECT); Common Interface (CI); Part 1: Overview".
- [2] prETS 300 175-2 (1996): "Radio Equipment and Systems (RES); Digital European Cordless Telecommunications (DECT); Common Interface (CI); Part 2: Physical Layer".
- [3] prETS 300 175-3 (1996): "Radio Equipment and Systems (RES); Digital European Cordless Telecommunications (DECT); Common Interface (CI); Part 3: Medium Access Control (MAC) layer".
- [4] prETS 300 175-4 (1996): "Radio Equipment and Systems (RES); Digital European Cordless Telecommunications (DECT); Common Interface (CI); Part 4: Data Link Control (DLC) layer".
- [5] prETS 300 175-5 (1996): "Radio Equipment and Systems (RES); Digital European Cordless Telecommunications (DECT); Common Interface (CI); Part 5: Network (NWK) layer".
- [6] prETS 300 175-6 (1996): "Radio Equipment and Systems (RES); Digital European Cordless Telecommunications (DECT); Common Interface (CI); Part 6: Identities and addressing".
- [7] prETS 300 175-7 (1996): "Radio Equipment and Systems (RES); Digital European Cordless Telecommunications (DECT); Common Interface (CI); Part 7: Security features".
- [8] prETS 300 175-8: "Radio Equipment and Systems (RES); Digital European Cordless Telecommunications (DECT); Common Interface (CI); Part 8: Speech coding and transmission".
- [9] ISO/IEC 9646-1 (1991): "Information technology - Open Systems Interconnection - Conformance testing methodology and framework - Part 1: General concepts". (See also CCITT Recommendation X.290 (1991)).
- [10] CCITT Recommendation V.11 (1988): "Electrical characteristics for balanced double-current interchange circuits operating at data signalling rates up to 10 Mbit/s".
- [11] CCITT Recommendation O.153 (1988): "Basic parameters for the measurement of error performance at bit rates below the primary rate".
- [12] 91/263/EEC: "Council Directive of 29 April 1991 on the approximation of the laws of the Member States concerning telecommunications terminal equipment, including the mutual recognition of their conformity" (Terminal Directive).
- [13] EN 55022: "Limits and methods of measurements of radio interferers characteristics of information technology equipment".
- [14] CCITT Recommendation G.726: "40, 32, 24, 16 kbit/s adaptive differential pulse code modulation (ADPCM)".

- [15] 89/336/EEC: "Council Directive of 3rd May 1989 on the approximation of the laws of the Member States relating to Electromagnetic Compatibility" (EMC Directive).

3 Definitions and abbreviations

3.1 Definitions

For the purposes of this ETS, the following definitions apply:

antenna diversity: Antenna diversity implies that the Radio Fixed Part (RFP) for each bearer independently can select different antenna properties such as gain, polarization, coverage patterns, and other features that may effect the practical coverage. A typical example is space diversity, provided by two vertically polarized antennas separated by 10 - 20 cm.

bearer handover: The internal handover process provided by the Medium Access Control (MAC) layer, whereby one MAC connection can modify its underlying bearers while maintaining the service provided to the Data Link Control (DLC) layer.

NOTE 1: Bearer handover is slot based.

cell: The domain served by a single antenna system (including a leaky feeder) of one FP.

NOTE 2: A cell may include more than one source of radiated Radio Frequency energy (i.e. more than one Radio End Point).

Central Control Fixed Part (CCFP): A physical grouping that contains the central elements of a FP. A FP shall contain a maximum of one CCFP.

NOTE 3: A CCFP controls one or more RFPs.

conducted measurements: Measurements which are made using a direct connection to the equipment under test.

DECT-like carrier: A modulated RF DECT carrier used for interference testing which conforms to the requirements in ETS 300 175-2 [2] in terms of frequency and timing and uses a pseudo-random sequence for modulation.

Double Slot (SLOT): One 12th of a Time Division Multiple Access (TDMA) frame which is used to support one high capacity physical channel.

duplex bearer: The use of two simplex bearers operating in opposite directions on two physical channels. These pairs of channels always use the same RF carrier and always use evenly spaced slots (i.e. separated by 0,5 TDMA frame).

Equipment Under Test (EUT): The equipment submitted to the test laboratory for type examination.

Fixed Part (DECT Fixed Part) (FP): A physical grouping that contains all of the elements in the DECT network between the local network and the DECT air interface.

NOTE 4: A DECT FP contains the logical elements of at least one Fixed radio Termination (FT), plus additional implementation specific elements.

Fixed radio Termination (FT): A logical group of functions that contains all of the DECT processes and procedures on the fixed side of the DECT air interface.

NOTE 5: A FT only includes elements that are defined in the DECT CI standard. This includes radio transmission elements (layer 1) together with a selection of layer 2 and layer 3 elements.

full slot (slot): One 24th of a TDMA frame which is used to support one physical channel.

half slot: One 48th of a TDMA frame which is used to support one physical channel.

handover: The process of switching a call in progress from one physical channel to another physical channel. These processes can be internal or external.

NOTE 6: There are two physical forms of handover: intra-cell handover and inter-cell handover. Intra-cell handover is always internal. Inter-cell handover can be internal or external.

host equipment: Is any equipment which has a complete user functionality when not connected to the DECT radio equipment, and to which the DECT radio equipment provides additional functionality, and to which connection is necessary for the DECT radio equipment to offer functionality.

inter-cell handover: The switching of a call in progress from one cell to another cell.

NOTE 7: This only defines the form of handover, it does not define a specific process.

intra-cell handover: The switching of a call in progress from one physical channel of one cell to another physical channel of the same cell.

NOTE 8: This only defines the form of handover, it does not define a specific process.

Lower Tester (LT): A logical grouping that contains the test equipment, a functionally equivalent DECT PT, a functionally equivalent DECT FT and a test controller.

multiframe: A repeating sequence of 16 successive TDMA frames, that allows low rate or sporadic information to be multiplexed (e.g. basic system information or paging).

physical channel (channel): The simplex channel that is created by transmitting in one particular slot on one particular RF channel in successive TDMA frames (see also simplex bearer).

NOTE 9: One physical channel provides a simplex service. Two physical channels are required to provide a duplex service.

Portable Handset (PHS): A single physical grouping that contains all of the portable elements that are needed to provide a teleservice to the user.

NOTE 10: PHS is a subset of all possible PPs. This subset includes all physical groupings that combine one PT plus at least one portable application in a single physical box.

Portable Part (PP): A physical grouping that contains all elements between the user and the DECT air interface. PP is a generic term that may describe one or several physical pieces.

NOTE 11: A PP is logically divided into one PT plus one or more portable applications.

Portable radio Termination (PT): A logical group of functions that contains all of the DECT processes and procedures on the portable side of the DECT air interface.

NOTE 12: A PT only includes elements that are defined in the DECT CI standard. This includes radio transmission elements together with a selection of layer 2 and layer 3 elements.

radiated measurements: Measurements which involve the absolute measurement of a radiated field.

Radio End Point (REP): A physical grouping that contains one radio transmitter/receiver, fixed or portable.

NOTE 13: A REP may operate only as a receiver or only as a transmitter.

Radio Fixed Part (RFP): One physical sub-group of a FP that contains all the REPs (one or more) that are connected to a single system of antennas.

simplex bearer: The MAC layer service that is created using one physical channel.

TDMA frame: A time-division multiplex of 10 ms duration, containing 24 successive full slots. A TDMA frame starts with the first bit period of full slot 0 and ends with the last bit period of full slot 23.

test laboratory: A body which performs conformance testing. This laboratory is accredited to perform 3rd party testing.

test load: The test load is a substantially non-reactive, non-radiating power attenuator which is capable of safely dissipating the power from the transmitter(s).

Upper Tester (UT): A logical grouping that controls the EUT when under test.

NOTE 14: Commands are sent from the LT to the UT to place the EUT in the appropriate test mode.

3.2 Abbreviations

For the purposes of this ETS, the following abbreviations apply:

ARI	Access Rights Identity
BER	Bit Error Ratio
CCFP	Call Control Fixed Part
CI	Common Interface
CTA	Cordless Terminal Adapter
CTM	Cordless Terminal Mobility
CTR	Common Technical Regulation
CW	Continuous Wave
dBm	dB relative to 1 mW
EIRP	Equivalent Isotropically Radiated Power
EMC	Electro-Magnetic Compatibility
emf	electro-motive force
ERP	Effective Radiated Power
EUT	Equipment Under Test
FP	Fixed Part
FT	Fixed radio Termination
GPS	Global Positioning System
IPEI	International Portable part Equipment Identity
ISDN	Integrated Services Digital Network
ISS	Internal System Synchronization
ITE	Information Technology Equipment
LT	Lower Tester
NTP	Normal Transmitted Power
OA&M	Operation, Administration and Maintenance
PHL	Physical
PICS	Protocol Implementation Conformance Statement
PIXIT	Protocol Implementation eXtra Information for Testing
PP	Portable Part
ppm	parts per million
PSCN	Primary receiver Scan Carrier Number
PSN	Portable equipment Serial Number
PSTN	Public Switched Telephone Network
PT	Portable radio Termination
RFP	Radio Fixed Part
RFPI	Radio Fixed Part Identity
RH	Relative Humidity
TBC	Traffic Bearer Controller (refer to ETS 300 175-3 [3])
TDMA	Time Division Multiple Access
TSM	Test Standby Mode
TSP	Test Support Profile
UT	Upper Tester
UTC	Universal Time Co-ordinated
VSWR	Voltage Standing Wave Ratio
WRS	Wireless Relay Station

4 General

4.1 Document layout

The test cases described in these subclauses are intended to follow the ISO/IEC 9646-1 [9] recommendations as closely as possible. However, for practical reasons it is not always possible to follow the guide-lines exactly and the following paragraphs describe the relationship of this ETS to ISO/IEC 9646-1 [9].

4.1.1 Test suites

The term "test suite" is defined in ISO/IEC 9646-1 [9].

Table 1 lists the test suite that is described in this ETS and the test groups that are associated with it.

Table 1: Test suite

Test suite	Test groups
DECT Physical (PHL) layer	PHL layer services Transmission of physical packets Reception of physical packets Synchronization Equipment identities Efficient use of radio spectrum

4.1.2 Test groups

The term "test group" is defined in ISO/IEC 9646-1 [9].

Table 2 lists the test groups that are described in this ETS and the test cases that are associated with them.

Table 2: Test groups

Test group	Test cases
Physical layer services	1 2 4
Transmission of physical packets	5 6 7 8 9 10 11 12
Reception of physical packets	14 15 16 17 18 19 20
Synchronization	21
Equipment identities	23
Efficient use of radio spectrum	24

4.1.3 Test cases

The term "test case" is defined in ISO/IEC 9646-1 [9].

Table 3 lists the test cases that are described in this ETS.

Table 3: Test cases

Test Case	Test case	Clause / subclause Number
1	Accuracy and stability of RF carriers	7
2	Timing jitter: slot-slot on the same channel	8.3
3	no longer required	
4	Reference timing accuracy of a RFP	8.4
4b	Measurement of packet timing accuracy	8.5
5	Transmission Burst	9
6	Transmitted power: PP and RFP with an integral antenna	10.2
7	Transmitted power: PP and RFP with an external antenna connector	10.3
8	RF carrier modulation	11
9	Emissions due to modulation	12.2
10	Emissions due to transmitter transients	12.3
11	Emissions due to intermodulation	12.4
12	Spurious emissions when allocated a transmit channel	12.5
13	no longer required	
14	Radio receiver sensitivity	13.1
15	Radio receiver reference bit error ratio	13.2
16	Radio receiver interference performance	13.3
17	Radio receiver blocking case 1	13.4
18	Radio receiver blocking case 2	13.5
19	Receiver intermodulation performance	13.6
20	Spurious emissions when the radio endpoint has no allocated transmit channel	13.7
21	Synchronization port	14
22	EMC	15
23	Equipment identity verification/safeguards	16
24	Efficient use of radio spectrum	17

Annex I provides a summary of the essential requirement articles of the Terminal Directive, 91/263/EEC [12] justifying the test cases of this ETS.

4.2 Presentation of equipment for testing purposes

Each equipment submitted for type examination shall fulfil the requirements of this ETS on all DECT RF channels.

4.2.1 Choice of model for type examination

The applicant shall provide one or more preliminary or production model(s) of the equipment, as appropriate, for type examination.

If approval is given on the basis of tests on a preliminary model, then the corresponding production models shall be identical in all respects with the preliminary model tested.

4.2.2 Description of equipment

The applicant shall provide the information in the following subclauses to the test laboratory.

4.2.2.1 Protocol Implementation Conformance Statement (PICS)

A statement made by the applicant stating which capabilities and options have been implemented.

4.2.2.2 Protocol Implementation eXtra Information for Testing (PIXIT)

A statement made by the applicant which contains or references all of the information (in addition to that given in the PICS) related to the EUT and its testing environment, which will enable the test laboratory to run an appropriate test suite against the EUT.

This shall include:

- the method by which the equipment can be switched into the test standby mode. This mode is described in subclause 5.9.2;
- whether the equipment has one or more internal or external antennas;
- whether the equipment has antenna diversity.

4.2.2.3 Environmental test conditions

The applicant shall supply for FPs, RFPs, and Call Control Fixed Parts (CCFPs), a statement indicating the class of use for the EUT, i.e. "Class E1 Use" or "Class E2 Use".

4.2.3 Host connected equipment

The applicant shall supply a statement indicating which of the test configurations detailed in subclause 6.7 shall be used for approval of DECT equipment for which connection to, or integration with, host equipment is required to offer functionality.

4.2.4 Applicant's declaration

Where parameters, capabilities, etc., are subject to applicant's declaration and not a specific test, it shall be the applicant's responsibility to:

- a) supply a declaration of implementation, in which the applicant explicitly affirms the implementation in the equipment of certain parameters and capabilities;
- b) be prepared to submit upon request supporting design information, including circuit designs and software source code, demonstrating the implementation of said capabilities;
- c) be prepared to supply upon request such test results as are practicable, including the test methods, which support the declaration.

4.3 Applicability of type tests

The applicability of the individual type tests in this ETS is dependent on the type of equipment submitted for approval. The following subclauses list the applicable type tests. Equipment may contain one or more of the features listed in the following subclauses. It is assumed that all equipment contains a radio receiver. The type tests described in this ETS shall only be applied to the equipment physically containing a DECT RF receiver and/or transceiver. Control lines to the EUT necessary for its operation shall be permitted.

4.3.1 Equipment that includes only a DECT RF receiver

The type test specified in subclause 13.7 shall be applied.

4.3.2 Equipment that includes a radio transmitter

The type tests contained in clauses 7, 8, 9, 10, 11, 12, 13 and 17 shall be applied. For equipment continuously transmitting (e.g. FP with dummy bearer) the type test specified in subclause 13.7 shall not apply.

4.3.3 Equipment that is equipped with an analogue port

Additional national type tests may be applied to equipment that are equipped with an analogue port.

4.3.4 Equipment with a synchronization port

The type tests contained in clause 14 shall be applied.

4.3.5 Equipment incorporating the IPEI (PPs only)

The type test contained in subclause 16.1 shall be applied.

4.3.6 All FP equipment

The type test contained in subclause 16.2 shall be applied.

4.3.7 PPs with direct PP to PP communication option

Direct PP to PP communication is supported. In this mode of operation, a PP sets up a call directly to another PP, and there is no requirement or need to being locked to an RFP. Since no RFP is involved in the communication link, direct PP to PP communication only uses half the spectrum compared to normal calls routed via RFPs.

The requirements for type test of PPs with direct PP to PP communication option are defined in annex G.

4.3.8 Installation related issues

DECT provides dynamic spectrum sharing between licensed and unlicensed uncoordinated system installations with a varying selection of speech, data and image services. The efficient use of the spectrum aspect of TBR 6 (see annex A) applies to all DECT equipment; mobiles (PP), base stations (RFP), Wireless Relay Stations (WRSs) and Cordless Terminal Adapters (CTAs). Thus there are installation related issues that are essential for the efficient use of the spectrum, that need to be defined.

Annex H contains requirements on installation related issues. These requirements may have impact on the type testing of specific EUT, but will by its nature normally not be confined to type tests. They may be referred to in the conditions for licensed and unlicensed DECT installations. The annex H will be updated and expanded based on experience and evolving DECT applications.

4.3.9 Wireless relay stations

WRSs shall be type approved to this ETS.

For European approval, no more than one hop is allowed. On a national basis, multi-hop architectures may be allowed with agreement of the national authority.

Each DECT profile shall use only one of the WRS concepts. In multi-hop architectures, the interface between WRSs are not subject to profile approval

4.4 Interpretation of the measurement results

The interpretation of the results recorded in a test report for the measurements described in this ETS shall be as follows:

- a) the measured value related to the corresponding limit shall be used to decide whether an equipment meets the minimum requirements of the standard. Allowance for uncertainty of the measurement shall only be given if this is permitted by the corresponding subclause on verdict criteria;
- b) the actual measurement uncertainty of the test laboratory carrying out the measurement, for each particular measurement, shall be included in the test report;
- c) the values of the actual measurement uncertainty shall be, for each measurement, equal to or lower than the figures given in subclause 5.8.5.

5 General test requirements

5.1 Test philosophy

All the tests in this ETS are based upon a common philosophy. This philosophy assumes that test equipment is capable of emulating a PT or FT that conforms to the DECT CI specification. Consequently, each test set-up consists of the test equipment being connected to the EUT, either by a radio link or via an antenna connector. Figures 1 and 2 show the possible test configurations.

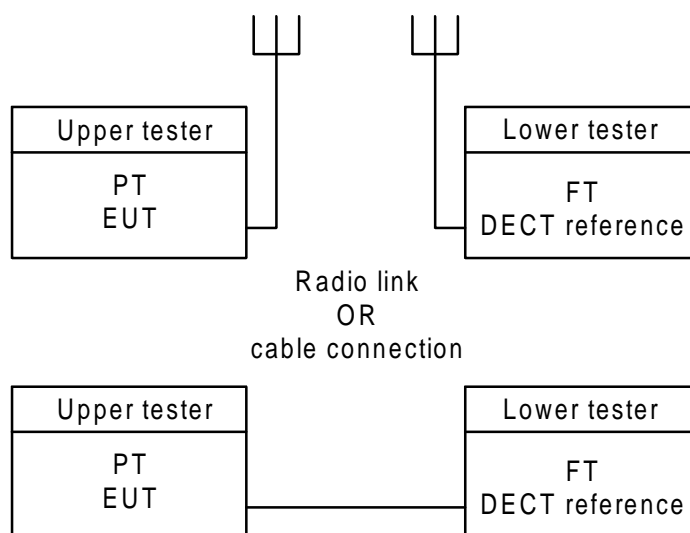

Figure 1: The EUT is a PT

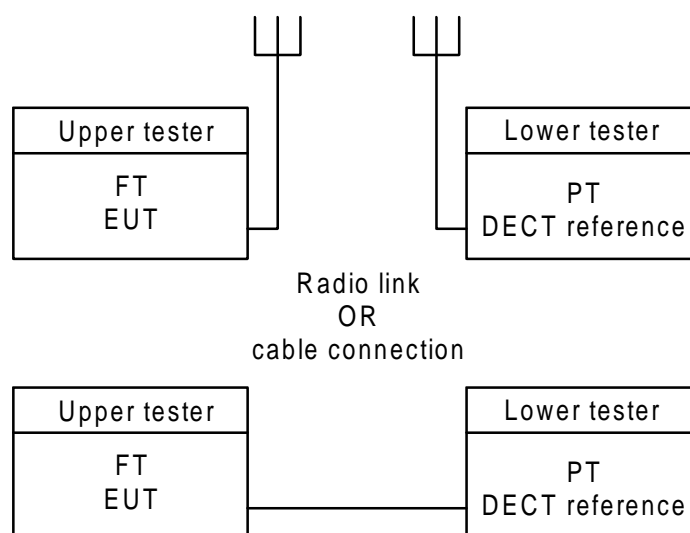

Figure 2: The EUT is an FT

Figures 1 and 2 also show that, if available, the EUT can sometimes be connected to the LT by an antenna connector. This is normally preferred in order to minimise the measurement uncertainties, however, in some test cases this is not permitted and is stated as such in each test case.

The LT shall consist of the general test equipment with the functionality as described in subclause 5.8. It shall also include an RF interface which can emulate a DECT PT, or FT. The emulated DECT PT and FT (see subclause 5.10) is an implementation of the DECT CI specification including all the mandatory services and facilities and some provision optional, process mandatory elements as well.

The UT is contained within the EUT and operates in response to test commands which are sent by the LT over the air interface. This enables the LT to place the EUT in a variety of test modes. These are described in subclause 5.9.

5.2 Test site

5.2.1 Open air test site

5.2.1.1 Description

The term "open air" shall be understood from an electromagnetic point of view. Such a test site may be really in open air or, alternatively, with walls and ceiling transparent to the radio waves at the frequencies considered.

An open air test site may be used to perform the measurements using the radiated measurement methods described in annex B in the frequency range over which the site may be calibrated. Absolute or relative measurements may be performed on transmitters or receivers; absolute measurements require a calibration of the test site.

The distance between the equipment under test or substitution antenna and the test antenna shall be in accordance with current testing practice. Measuring distances of 3 m, 5 m, 10 m, and 30 m are in common use in European test laboratories. A measurement distance of 1 m may be used for frequencies above 1 GHz if the dimensions of the test antenna is less than $[1 \text{ m} \times \lambda/2]^{1/2}$.

The test site shall be large enough to allow the erection of a measuring or transmitting antenna at a distance of $\lambda/2$ at the frequency of measurement or 3 m (1 m above 1 GHz), whichever is the greater. The height of the equipment or of the substitution antenna shall be 1,5 m; the height of the test antenna (transmit or receive) shall be variable between 1 and 4 m. The support for the equipment or substitution antenna shall be capable of 360° rotation and be made of a non-conductive material. The overall size of the open air test site shall be approximately 2 x D m by 3 x D m, where D is the measuring distance.

To eliminate errors caused by reflection coefficient variation from one measurement geometry to another, the standard ground plane should be substantially flat and horizontal; it should be made from a highly conductive metal. It shall be large enough (at least 5 m in diameter) to provide consistent ground reflections. The support for the equipment or substitution antenna shall be positioned in the middle of the ground plane. Sufficient precautions shall be taken to ensure that reflections from extraneous objects adjacent to the site do not degrade the measurement results, in particular:

- no extraneous conducting objects having any dimension in excess of a quarter wavelength of the highest frequency tested shall be in the immediate vicinity of the site;
- all cables shall be as short as possible; as much of the cables as possible shall be on the ground plane or preferably below and the low impedance cables shall be screened.

5.2.1.2 Calibration

The calibration allows the creation, in a given place, of a known field strength by the means of a signal generator connected to a substitution antenna. The calibration is valid only at a given frequency for a given polarization and for the exact position of the test antenna.

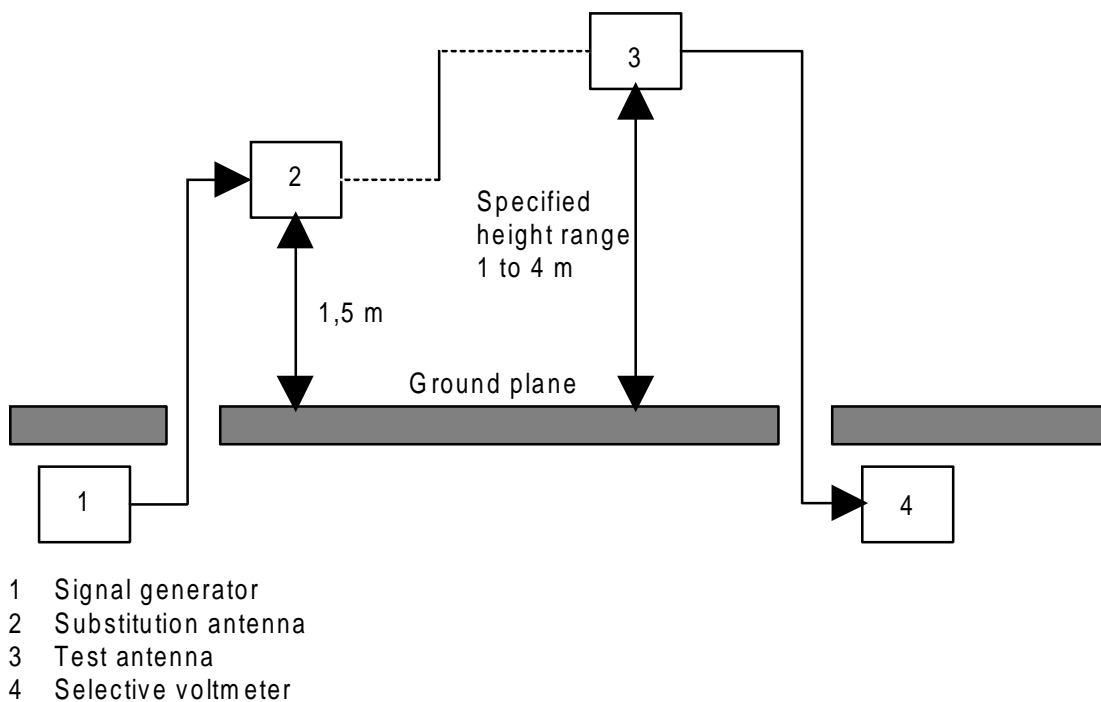

Figure 3: Measuring arrangement for calibration

All the equipment shall be adjusted to the frequency at which the calibration is to be performed.

The test antenna and the substitution antenna shall have the same polarization.

The test antenna connected to the selective voltmeter constitutes a calibrated field strength meter:

- a) the signal generator level shall be adjusted to produce the required field strength as measured on the selective voltmeter;
- b) the test antenna shall be raised or lowered through the specified range until the maximum signal level is detected on the selective voltmeter;
- c) the signal generator level shall be readjusted to produce the required field strength as measured on the selective voltmeter. Thus a relationship has been established between the signal generator level and the field strength.

5.2.2 Anechoic chamber

5.2.2.1 General

An anechoic chamber is a well shielded chamber covered inside with RF absorbing material and simulating a free space environment. It is an alternative site on which to perform the measurements using the radiated measurement methods described in annex B in the frequency range over which it may be calibrated. Absolute or relative measurements may be performed on transmitters or on receivers. Absolute measurements require a calibration of the anechoic chamber. The test antenna, equipment under test and substitution antenna are used in a way similar to that at the open air test site, but are all located at the same fixed height above the floor.

5.2.2.2 Description

An anechoic chamber should meet the requirements for shielding loss and wall return loss as shown in figure 4. Figure 5 shows an example of the construction of an anechoic chamber having a base area of 5 m by 10 m and a height of 5 m.

The ceiling and walls are coated with pyramidal absorbers approximately 1 metre high. The base is covered with special absorbers which form the floor. The available internal dimensions of the chamber are 3 m x 8 m x 3 m, so that a maximum measuring distance of 5 m in the middle axis of this chamber is available (for more information, see ZVEI AK-R 90/20, annex A). The floor absorbers reject floor reflections so that the antenna height need not be changed. Anechoic chambers of other dimensions may be used.

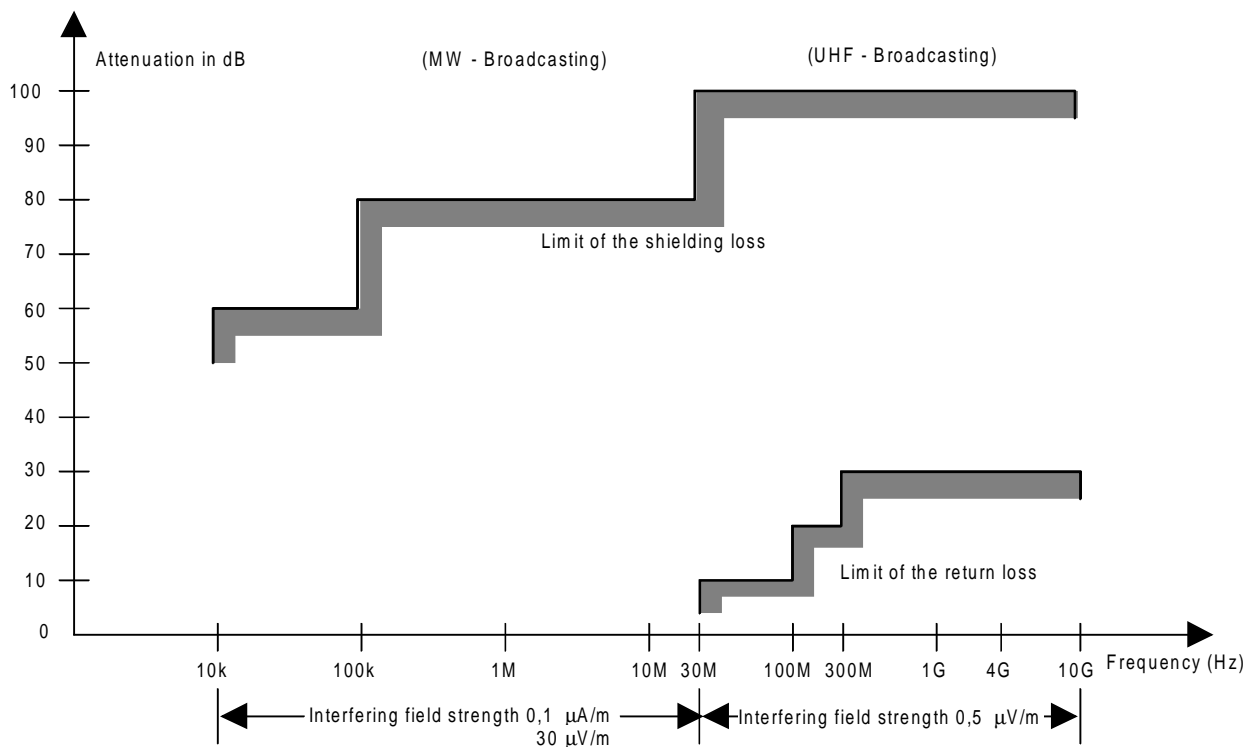

Figure 4

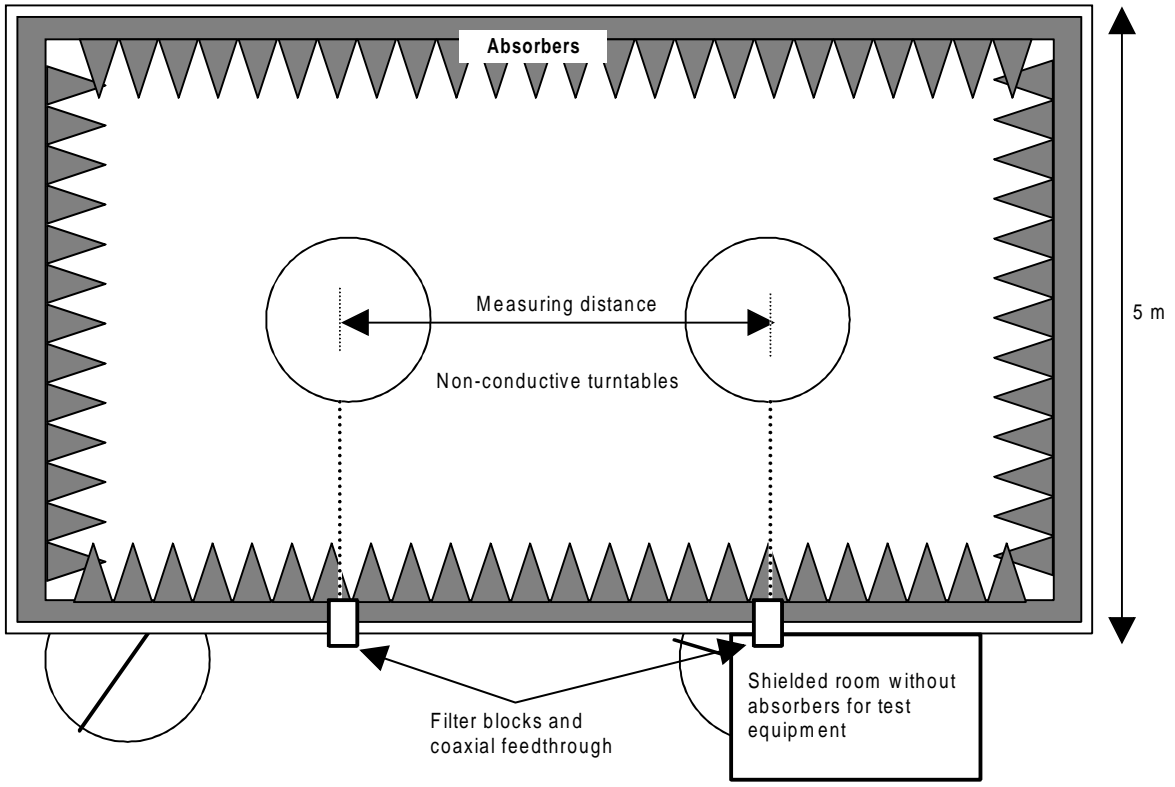
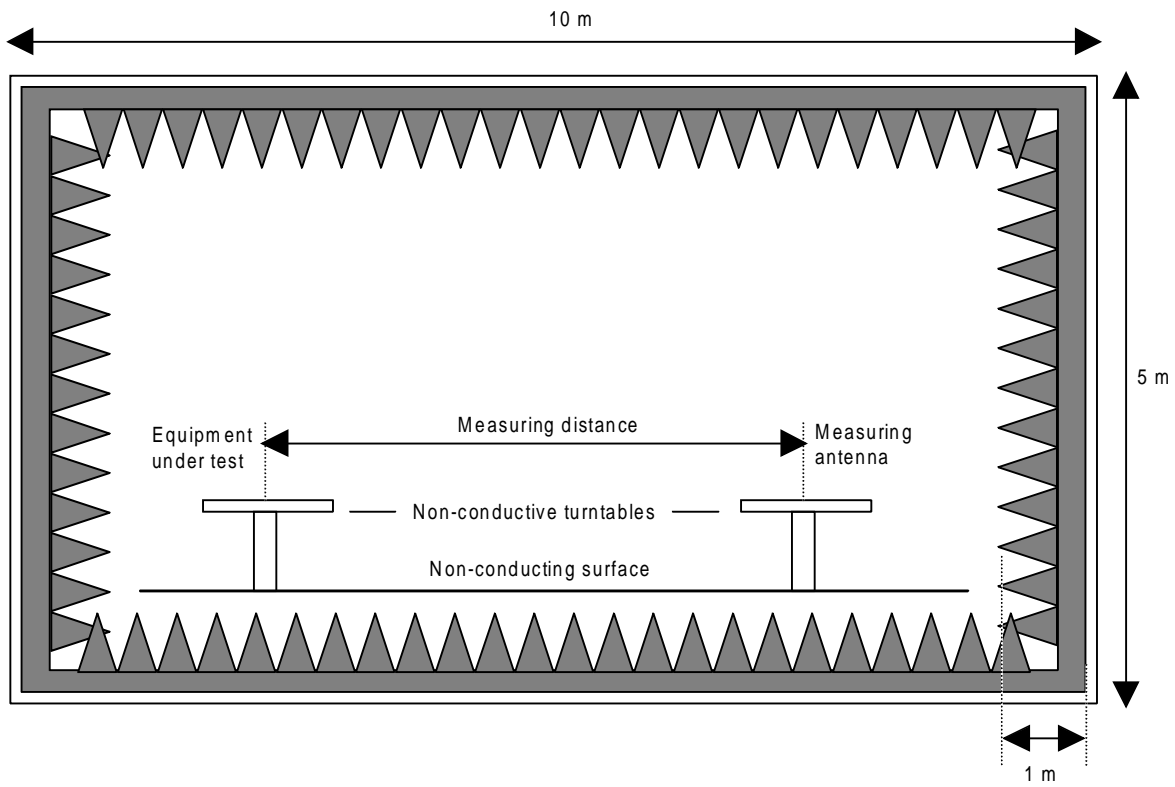

Figure 5

5.2.2.3 Influence of parasitic reflections

For free-space propagation in the far field the relationship of the field strength X and the distance R is given by:

$$X = X_0 \times (R_0/R) \quad (1)$$

where X_0 is the reference field strength and R_0 is the reference distance. This relationship allows relative measurements to be made as all constants are eliminated within the ratio and neither cable attenuation nor antenna mismatch or antenna dimensions are of importance.

If the logarithm of above equation (1) is used, the deviation from the ideal curve can be easily seen because the ideal correlation of field strength and distance appears as a straight line. The deviations occurring in practice are then clearly visible. This indirect method shows quickly and easily any disturbances due to reflections and is far less difficult than the direct measurement of reflection attenuation.

With an anechoic chamber of the dimensions given above at low frequencies below 100 MHz there are no far field conditions, but the wall reflections are stronger, so that careful calibration is necessary. In the medium frequency range from 100 MHz to 1 GHz the dependence of the field strength to the distance meets the expectations very well. Above 1 GHz, because more reflections will occur, the dependence of the field strength to the distance will not correlate so closely.

5.2.2.4 Calibration and mode of use

The calibration and mode of use is the same as for an open air test site, the only difference being that the test antenna does not need to be raised and lowered whilst searching for a maximum, which simplifies the method of measurement.

5.2.3 Stripline coupler

The stripline arrangement is a RF coupling device for coupling the integral antenna of an equipment to a 50 Ω radio frequency terminal. This allows the radiated measurements described in clause 5 to be performed without an open air test site but in a restricted frequency range. Absolute or relative measurements may be performed; absolute measurements require a calibration of the stripline arrangement.

5.2.3.1 Description

The stripline is made of three highly conductive sheets forming part of a transmission line which allows the equipment under test to be placed within a known electric field. They shall be sufficiently rigid to support the equipment under test.

An example of stripline characteristics is given below:

- Useful frequency range:		0,1 MHz to 4 000 MHz
- Equipment size limits	length	1 200 mm
- (antenna included):	width	1 200 mm
- height:		400 mm

See report FTZ N° 512 TB 9, (see annex A) for more information.

5.2.3.2 Calibration

The aim of calibration is to establish at any frequency a relationship between the voltage applied by the signal generator and the field strength at the designated test area inside the stripline.

5.2.3.3 Mode of use

The stripline arrangement may be used for all radiated measurements within its calibrated frequency range.

The method of measurement shall be the same as the method using a open air test site with the following change. The stripline arrangement input socket shall be used instead of the test antenna.

5.3 Standard position

The standard position in all test sites, except the stripline arrangement, for equipment which is not intended to be worn on a person, including hand-held equipment, shall be on a non-conducting support, height 1,5 m, capable of rotating about a vertical axis through the equipment. The standard position of the equipment shall be the following:

- a) for equipment with an integral antenna, it shall stand so that the axis of the equipment which in its normal use is closest to the vertical shall be vertical;
- b) for equipment with a rigid external antenna, the antenna shall be vertical;
- c) for equipment with a non-rigid external antenna, the antenna shall be extended vertically upwards by a non-conducting support.

In the stripline arrangement the equipment under test or the substitution antenna is placed in the designated test area in the normal operational position, relative to the applied field, on a pedestal made of a low dielectric material (dielectric constant less than 2).

5.4 Test antenna of the LT

When the test site is used for radiation measurements the test antenna shall be used for reception of the field from both the test sample and the substitution antenna. When the test site is used for the measurement of receiver characteristics the antenna shall be used as a transmitting antenna. This antenna shall be mounted on a support capable of allowing the antenna to be used in either a horizontal or vertical polarization and for the height of its centre above the ground to be varied over the specified range. Preferably test antennas with pronounced directivity should be used. The size of the test antenna along the measurement axis shall not exceed 20 % of the measuring distance.

5.5 Substitution antenna

The substitution antenna shall be used to replace the equipment under test. For measurements below 1 GHz the substitution antenna shall be a half wavelength dipole resonant at the frequency under consideration, or a shortened dipole, calibrated to the half wavelength dipole. For measurements between 1 and 4 GHz either a half wavelength dipole or a horn radiator may be used.

For measurements above 4 GHz a horn radiator shall be used. The centre of this antenna shall coincide with the reference point of the test sample it has replaced. This reference point shall be the volume centre of the sample when its antenna is mounted inside the cabinet, or the point where an outside antenna is connected to the cabinet.

Above 1 GHz the gain of the substitution antenna shall be relative to an isotropic radiator.

Below 1 GHz where a dipole is used as the substitution antenna no gain correction is needed.

The distance between the lower extremity of the dipole and the ground shall be at least 30 cm.

NOTE: The gain of a horn antenna is generally expressed relative to an isotropic radiator.

5.6 Test fixture

5.6.1 Description

The test fixture is a radio frequency coupling device associated with an integral antenna equipment for coupling the integral antenna to a 50 Ω radio frequency terminal at the working frequencies of the equipment under test. This allows certain measurements to be performed using the conducted measurement methods. Measurements may only be performed at or near frequencies for which the test fixture has been calibrated.

In addition, the test fixture shall provide:

- 1) a connection to an external power supply; and
- 2) interfaces to other relevant inputs and outputs.

The test fixture shall normally be provided by the applicant.

The performance characteristics of the test fixture shall be approved by the test laboratory and shall conform to the following basic parameters:

- a) the coupling loss shall not be greater than 20 dB;
- b) a coupling loss variation over the frequency range used in the measurement which does not exceed 2 dB;
- c) circuitry associated with the RF coupling shall contain no active or non linear devices;
- d) the Voltage Standing Wave Ratio (VSWR) at the 50 Ω socket shall not be greater than 1,5 over the frequency range of the measurements;
- e) the coupling loss shall be independent of the position of the test fixture and be unaffected by the proximity of surrounding objects or people. The coupling loss shall be reproducible when the equipment under test is removed and replaced;
- f) the coupling loss shall remain substantially constant when the environmental conditions are varied.

The characteristics and calibration shall be included in the test report.

5.6.1.1 Calibration of the test fixture for the measurement of transmitter characteristics

The calibration of the test fixture establishes a relationship between the output of the test fixture and the output of the equipment inside the test fixture.

The calibration is valid only at a given frequency or range of frequencies and for a given polarization of the reference field.

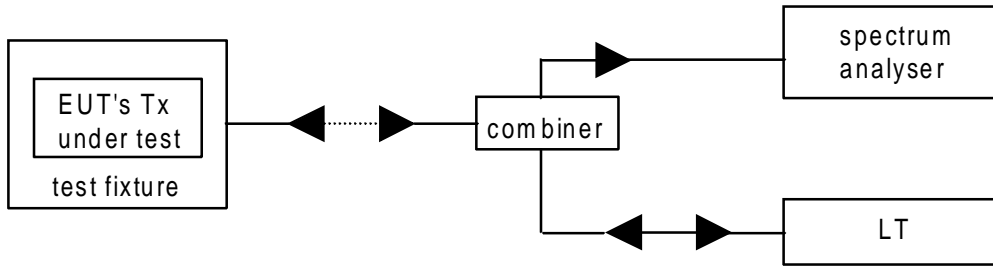

Figure 6: Measuring arrangement for calibration

- a) Using the appropriate method described in subclauses 10.2 and 10.3 (transmitted power) measure the NTP and note the value of this power and the polarization used.
- b) The transmitter shall be placed in the test fixture which is connected to the spectrum analyser. The measured level in dBm shall be noted.
- c) The calibration for the test fixture is the linear relationship between the measured power in dBm according to clause 10 (transmitted power) and the measured power in dBm in this calibration set-up.

5.6.1.2 Calibration of the test fixture for the measurement of receiver characteristics

The calibration of the test fixture establishes a relationship between the level of the signal connected to the test fixture and the field strength applied to the equipment inside the test fixture.

The calibration is valid only at a given frequency and for a given polarization of the reference field.

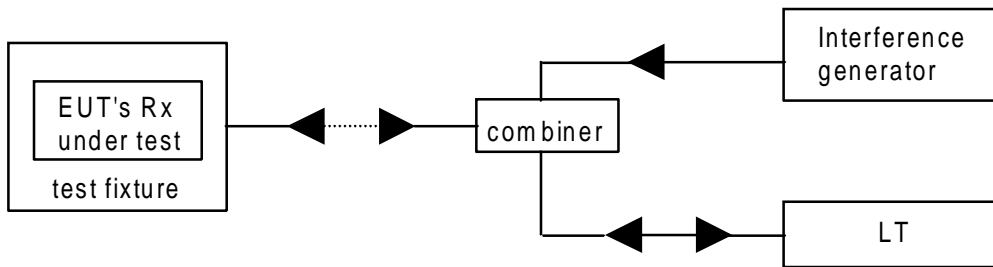

Figure 7: Measuring arrangement for calibration

- a) Using the method described in annex B, measure the sensitivity expressed as field strength for a Bit Error Ratio (BER) of 0,001 or less and note the value of this field strength in dB μ V/m and the polarization used.
- b) The receiver shall be placed in the test fixture which is connected to the LT (with BER measuring test facilities). The level of the signal connected to the test fixture producing the same BER measured according to the method used in step a) shall be noted.
- c) The calibration of the test fixture is thus the linear relationship between field strength in dB μ V/m and the signal generator level in dB μ V emf.

5.6.1.3 Mode of use

A test fixture may be used for tests under extreme temperatures and for transmitter and receiver measurements that can be carried out with an uncalibrated test fixture.

If the calibrated test fixture is used as an alternative for the test site then its use, the characteristics and the calibration shall be recorded in the test report.

5.6.2 Equipment with a temporary or internal permanent antenna connector

The means to access and/or implement the internal permanent or temporary antenna connector shall be stated by the applicant with the aid of a diagram.

The fact that use has been made of the internal antenna connection to facilitate measurements shall be recorded in the test report.

All references in this ETS to antenna connector, external antenna connector and temporary connectors shall be understood to be identical and to mean an external antenna connector and/or temporary and/or internal permanent connector.

5.6.2.1 Equipment with a temporary antenna connector

The applicant, or an authorized representative, may submit one set of equipment with the normal antenna connected, to enable the radiated measurements to be made.

The applicant, or an authorized representative, shall attend the test laboratory at conclusion of the radiated measurements, to disconnect the antenna and fit the temporary connector.

The test laboratory staff shall not connect or disconnect any temporary antenna connector.

Alternatively the applicant, or an authorized representative, may submit two sets of equipment to the test laboratory, one fitted with a temporary antenna connector with the antenna disconnected and the other with the antenna connected.

Each equipment shall be used for the appropriate tests.

5.7 Indoor test site

An indoor test site may be used instead of an open air test site or an anechoic room. However, the open air test site or the anechoic room are preferred. Each test case lists the allowed test sites.

5.7.1 Description

An indoor test site is a partially screened site, where the wall located behind the test sample is covered with a radio frequency absorbing material and a corner reflector is used with the test antenna. It may be used when the frequency of the signals being measured is greater than 80 MHz.

The measurement site may be a laboratory room with a minimum area of 6 m by 7 m and at least 2,7 m in height.

Apart from the measuring apparatus and the operator, the room shall be as free as possible from reflecting objects other than the walls, floor and ceiling.

The site arrangement is shown in figure 8 for horizontal polarization.

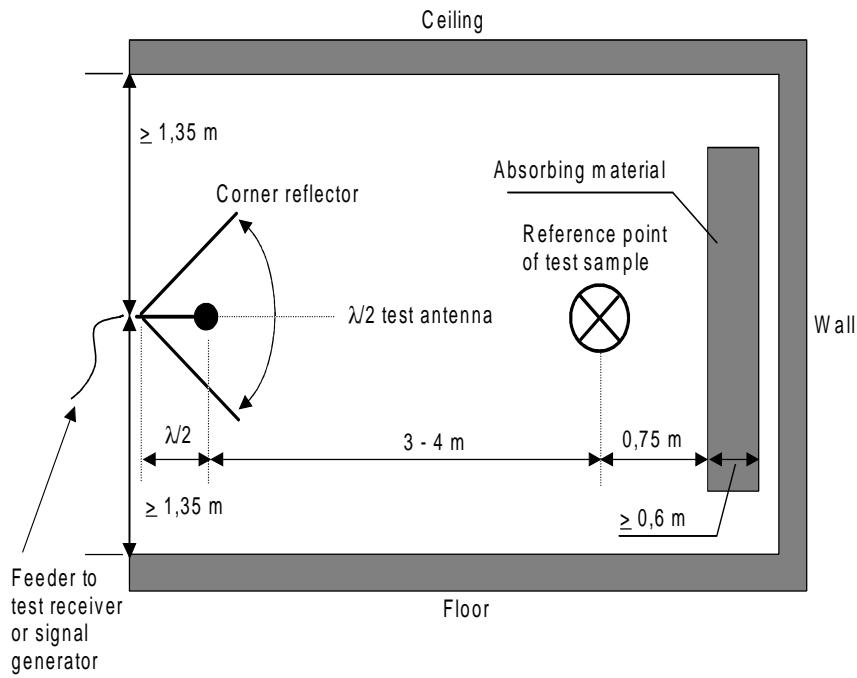

Figure 8: Indoor test site arrangement (shown for horizontal position)

The potential reflections from the wall behind the equipment under test shall be reduced by placing a barrier of absorbent material in front of the wall. The corner reflector around the test antenna shall be used to reduce the effect of reflections from the opposite wall and from the floor and ceiling in the case of horizontally polarized measurements. Similarly, the corner reflector reduces the effects of reflections from the side walls for vertically polarized measurements. For the lower part of the frequency range (below approximately 175 MHz) no corner reflector or absorbent barrier is needed. For practical reasons, the half wavelength antenna in figure 8 may be replaced by an antenna of constant length, provided that this length is between a quarter wavelength and one wavelength at the frequency of measurement and the sensitivity of the measuring system is sufficient. In the same way the distance of half wavelength to the apex may be varied.

5.7.2 Test for parasitic reflections

To ensure that errors are not caused by the propagation path approaching the point at which phase cancellation between direct and the remaining reflected signals occurs, the substitution antenna shall be moved through a distance of ± 10 cm in the direction of the test antenna as well as in the two directions perpendicular to this first direction.

If these changes of distance cause a signal change of greater than 2 dB, the test sample should be repositioned until a change of less than 2 dB is obtained.

5.7.3 Calibration and mode of use

The calibration and mode of use is the same as for an open air test site, the only difference being that the test antenna does not need to be raised and lowered whilst searching for a maximum, which simplifies the method of measurement.

5.8 Lower Tester (LT)

5.8.1 Description

The lower tester is a logical grouping that contains a DECT PT, DECT FT, the measurement equipment and the controller of the DECT testing system. The LT has the job of sending testing commands, performing calculations (e.g. signal processing) and interacting with the EUT for the various tests. The LT may implement the Test Support Profile (TSP) described in annex D in order to support the test messages and procedures in a fully standardized manner. This unit is also involved with DECT RF carrier generation, reception, and demodulation. In addition, the LT has wideband RF requirements for emissions and interference testing.

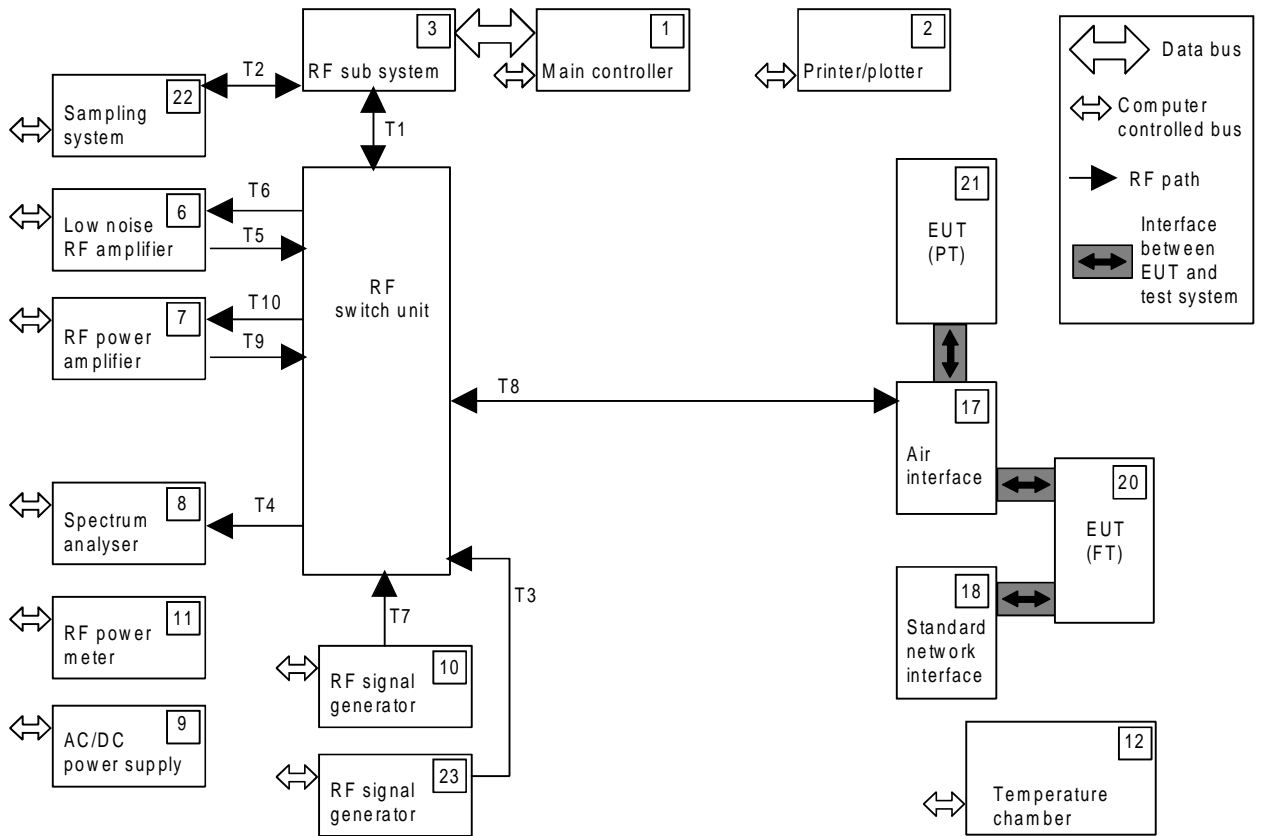

Figure 9: Functional contents of the LT

5.8.2 Connections between the EUT and the LT

This is specified in each test case.

5.8.3 Functions and abilities

The LT shall include all the functions necessary to perform the tests described in this ETS.

These include the ability to:

- generate one actual DECT RF signal;
- generate one Modulated DECT-like carrier;
- generate Continuous Wave (CW) interferer(s);
- sample and store an accurate representation of the EUT's RF signal;
- transmit a variety of test data sequences in the B-field;
- transmit on more than one slot per frame;
- make measurements as described in this ETS according to the uncertainties described in subclause 5.8.5;
- emulate a DECT FT, with the possibility to programme all DECT identity codes;
- emulate a DECT PT, with the possibility to programme all DECT identity codes.

5.8.4 Signal generation uncertainty

Carrier frequency: ± 5 kHz.

5.8.4.1 Modulated DECT-like carrier

This is a RF carrier using Gaussian shaped frequency-shift keying ($BT = 0,5$) modulated with a 1 152 kbit/s pseudo-random sequence with minimum length 2^9-1 . If the signal is bursted, it is required that the burst is synchronized to the DECT test signal generated by the LT.

5.8.4.2 CW interferers

The uncertainty shall be determined by the overall BER measurement uncertainty of a test case. This is specified in subclause 5.8.5.

5.8.4.3 DECT RF Signal

The carrier is defined using the method of subclause 7.3 and it shall meet the requirements needed to fulfil measurement uncertainties of subclause 5.8.5.

5.8.4.4 Test modulation signals

The test modulating signal is a baseband signal which modulates a carrier and is dependent upon the type of equipment under test and also the measurement to be performed.

Signals for data (bit stream):

D-M2: A signal representing a pseudo-random bit sequence of at least 511 bits in accordance with CCITT Recommendation O.153 [11]. This sequence shall be continuously repeated. This signal shall be used as a wanted signal.

5.8.5 Measurement uncertainty

The following values of measurement uncertainty associated with each measurement parameter apply to all of the test cases described in this ETS.

Relative drift radio frequency	± 2 kHz
Absolute radio frequency:	± 10 kHz
Conducted emissions:	± 1 dB
Radiated emissions:	± 3 dB
Absolute RF power (via an antenna connector):	± 1 dB
Absolute RF power (for unwanted emissions in the DECT band):	± 4 dB
Absolute RF power (for unwanted emissions outside the DECT band):	
	conducted: ± 4 dB
	radiated: ± 6 dB
Relative RF power:	± 1 dB
Absolute RF power (radiated):	± 3 dB
Relative Packet timing:	$\pm 0,1$ μ s
Absolute Packet timing:	± 1 μ s
Timing stability of FT:	1 ppm
Transmitter burst transient time:	± 20 % (of the measured value)
Peak frequency deviation	± 10 kHz

NOTE: All figures reflect a 95 % confidence level.

5.9 Upper Tester (UT)

5.9.1 Description of the UT

The UT is part of, but not necessarily restricted to, the EUT. For the purpose of testing, an EUT capable of transmitting shall recognize a mandatory set of test commands sent by the LT. The ability to recognize and implement these commands is contained in the UT which is resident in the medium access control layer as described in ETS 300 175-3 [3], and as refined by clause 18. All DECT equipment shall be capable of recognizing these commands. An EUT which is declared as implementing the TSP shall implement the provisions of the TSP described in annex D. The implementation of the TSP is not mandatory.

5.9.2 The test standby mode

Accessibility to these messages is controlled by some means of mechanical interlocking method or manual switching (e.g. dip-switch, jumper, prom, or key-pad code as designated by the applicant) to prevent accidental execution of these messages in a DECT user environment.

When the EUT has been switched into a mode whereby the test messages are accessible, the EUT is said to be in the test standby mode.

5.9.3 Test messages

The MAC layer test messages provide the following functions:

- a) instruct the EUT to transmit on a LT-specified physical channel. The test message also determines whether the handover function of the EUT (if so equipped) is disabled and if previous bearers are to be maintained (see ETS 300 175-3 [3], subclauses 7.2.5.4.2 and 12.3);
- b) instruct the EUT to perform the loopback function in which a test data pattern transmitted by the LT is replicated in the reply transmission of the EUT. The test data pattern is a bit sequence located in the D-fields of the LT and EUT. The bits of the D-field that are affected by the loopback function depends on the equipment type and are as follows:

Equipment type	Loopback Bits
Transmits only A-field	a_{16} to a_{47}
Transmits half-slots	b_0 to b_{79}
Transmits full-slots	b_0 to b_{319}
Transmits double-slots	b_0 to b_{799}

Equipment capable of transmitting more than one slot type shall use the longest slot type for this test message, (see ETS 300 175-3 [3], subclauses 7.2.5.4.3 and 12.4);

- c) defeat antenna diversity and select the specified antenna for operation in those EUTs possessing antenna diversity (see ETS 300 175-3 [3], subclauses 7.2.5.4.4 and 12.5);
- d) initiate the bearer handover procedure resident in an EUT that is declared by the applicant as possessing bearer handover capability (see ETS 300 175-3 [3], subclauses 7.2.5.4.5 and 12.6);
- e) permit inclusion of proprietary test messages by means of the "escape" code (see ETS 300 175-3 [3], subclauses 7.2.5.4.6 and 12.8);
- f) pass test messages (when applicable) to the network layer of the EUT, see ETS 300 175-3 [3], subclauses 7.2.5.4.7 and 12.7);
- g) provide for a means to reset the test state of the EUT by means of the "clear test modes" message (see ETS 300 175-3 [3], subclauses 7.2.5.4.8 and 12.9).

5.10 Description of the lower tester FT and PT

The lower tester FT and PT are systems consisting of the RF equipment, controller(s), software, and other related components necessary to be capable of implementing all the functions defined in the DECT specification documents.

5.11 General test methods

5.11.1 General

It is recognized that for some parameters alternative test methods may exist. It is the responsibility of the test laboratory to ensure that any alternative test method used yields results identical to those described in this ETS.

5.11.2 Sampling the RF signal

5.11.2.1 Introduction

A number of tests in this ETS require the RF signal to be sampled and demodulated. The following text describes the sampling method that should be performed in the LT.

5.11.2.2 Sampling method

The equipment under test shall be connected to the LT. This connection shall be direct for an EUT having an antenna connector or via an antenna coupling device for an EUT with an integral antenna and not having means of connecting an external antenna, unless otherwise specified in this ETS.

Handover (if available) shall be disabled in the EUT while the sampling takes place (see subclause 5.9.3 for the appropriate test message reference).

Antenna diversity (if available) shall be disabled in the EUT while the sampling takes place see subclause 5.9.3 for the appropriate test message reference).

Using a sampling measurement method, capture a representation of the EUT's transmitted RF signal. The position in a physical packet shall be calculated using the samples from the physical packet, knowing the received bit pattern. These calculated bit positions shall be used as the time reference when making measurements of RF frequency, phase and power.

NOTE: When reference is made to p_0 in this ETS, for example, it is intended that its position is calculated using many samples of a physical packet. The frequency, power or phase at this theoretical position of p_0 can then be measured.

5.11.3 Determining the reference position

During many tests the EUT is required to be oriented specifically in relation to the test antenna connected to the LT.

This position is called the reference position and is defined in the following subclauses.

5.11.3.1 Case 1: EUTs that cannot transmit

If the EUT has only an integral antenna then the applicant shall inform the test laboratory of the orientation of the integral antenna.

5.11.3.2 Case 2: EUTs that can transmit

The EUT shall be placed in a mode whereby it is transmitting.

NOTE: For most tests the EUT will have already been placed in a transmission mode.

The EUT shall be rotated in both horizontal and vertical planes in order to locate the direction of maximum field strength that is detected by the test antenna. This orientation shall be called the reference position.

5.11.4 Bit error rate (BER) measurements

BER measurements are carried out by comparing data in the loop back field transmitted by the LT with data in the loop back field received from the EUT (which is in loop back mode).

If the EUT does not recognize the sync word of the frame transmitted by the LT and therefore is unable to loop back any data, this frame shall be disregarded from the BER measurement.

Refer to annex E and annex F for further information.

5.12 Test set-up

Test set-ups have been defined according to ISO/IEC 9646-1 [9]. The test cases listed in table 3 have an associated test set-up.

The numbers inside the figures shown in subclauses 5.12.1 to 5.12.5 refer to functional blocks inside the LT. These are shown in figure 9 in subclause 5.8.1.

5.12.1 Test set-up 1

For the test set-up depicted in figure 10, the following test cases apply:

Test Case: 1, 2, 3, 4, 5, 6, 7, 8, 14, and 15.

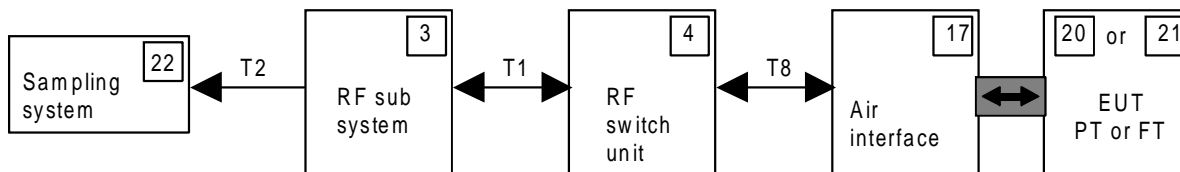

Figure 10: Test set-up 1

5.12.2 Test set-up 2

For the test set-up depicted in figure 11, the following test cases apply:

Test Case: 16 and 18.

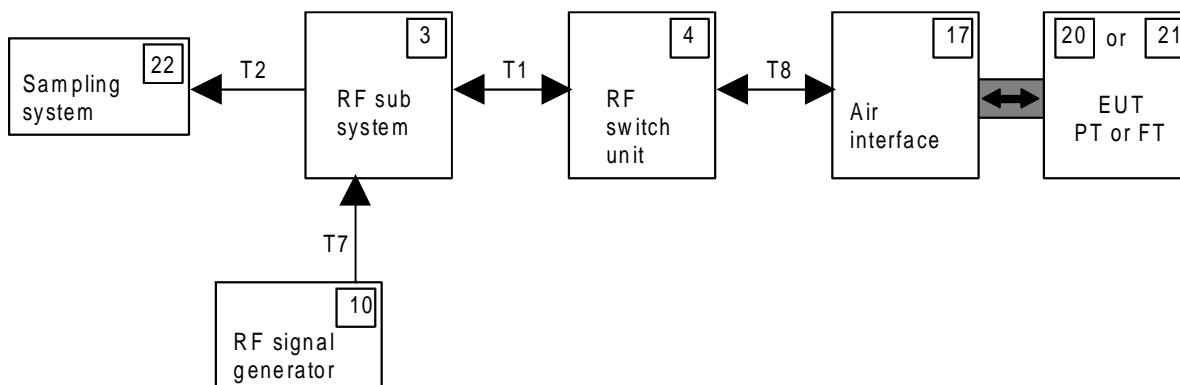

Figure 11: Test set-up 2

5.12.3 Test set-up 3

For the test set-up depicted in figure 12, the following test case applies:

Test Case: 19.

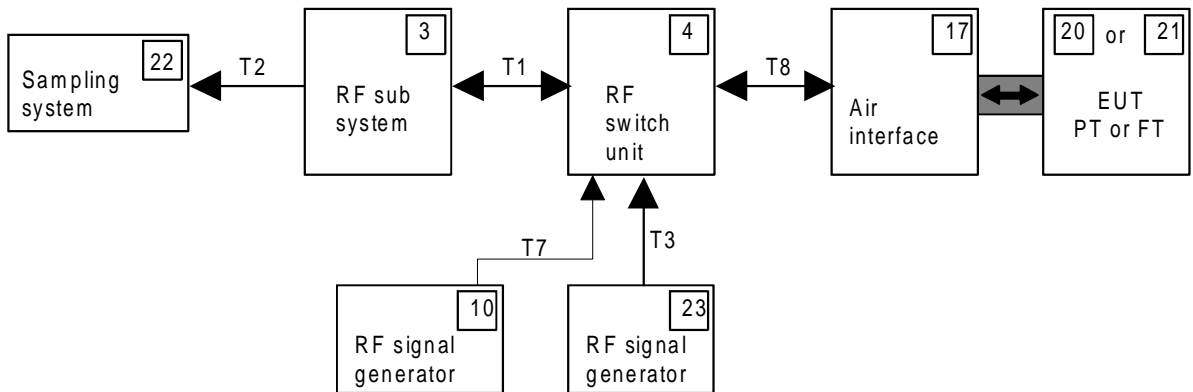

Figure 12: Test set-up 3

5.12.4 Test set-up 4

For the test set-up depicted in figure 13, the following test cases apply:

Test Case: 9, 10, 11, 12, 13, and 20.

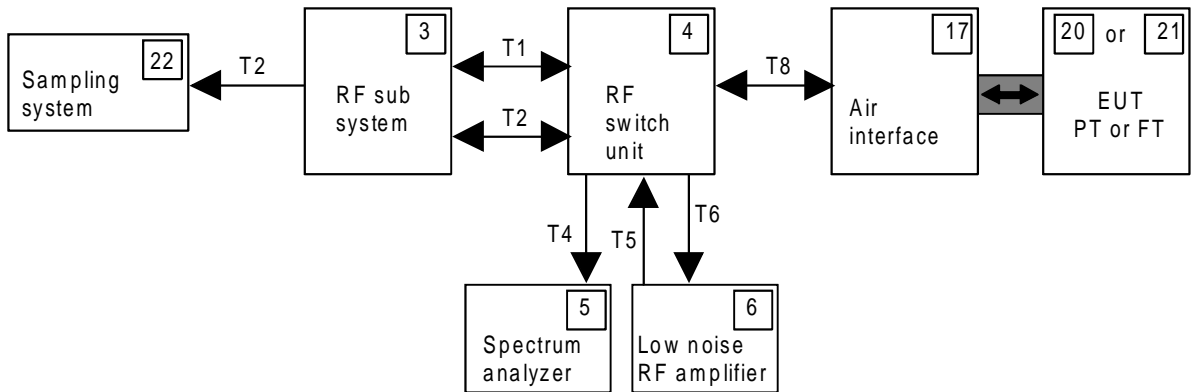

Figure 13: Test set-up 4

5.12.5 Test set-up 5

For the test set-up depicted in figure 14, the following test case applies:

Test Case: 17.

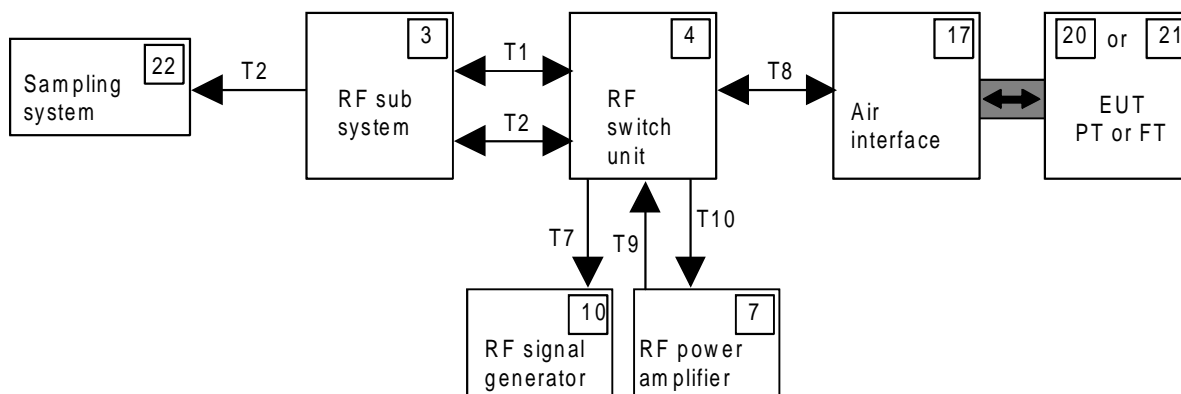

Figure 14: Test set-up 5

5.13 Test arrangements for intermodulation measurements

5.13.1 PT to PT arrangement

In the PT to PT situation, the minimum distance for non-interference operation is specified as being 0,5 metres. Figure 15 shows the testing arrangement:

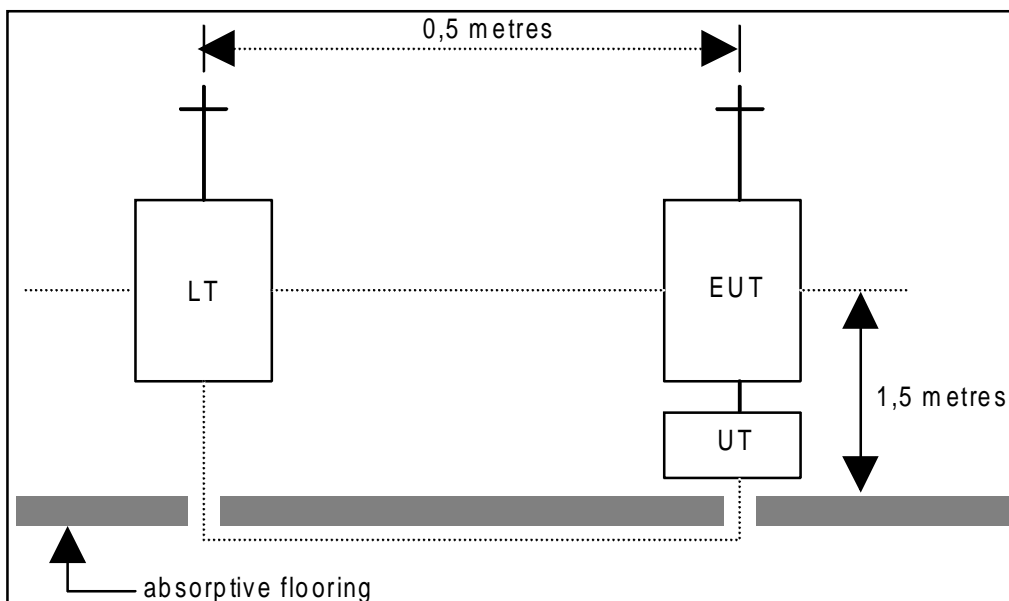

Figure 15

The elevation of the antennas are the same. Absorptive flooring is used to minimise reflection effects. The link between the UT and the EUT indicates the control of the EUT via the DECT air interface.

5.13.2 FT to FT arrangement

In the FT to FT situation, the minimum distance for non-interference operation is specified as being 1 m. Figure 16 shows the testing arrangement:

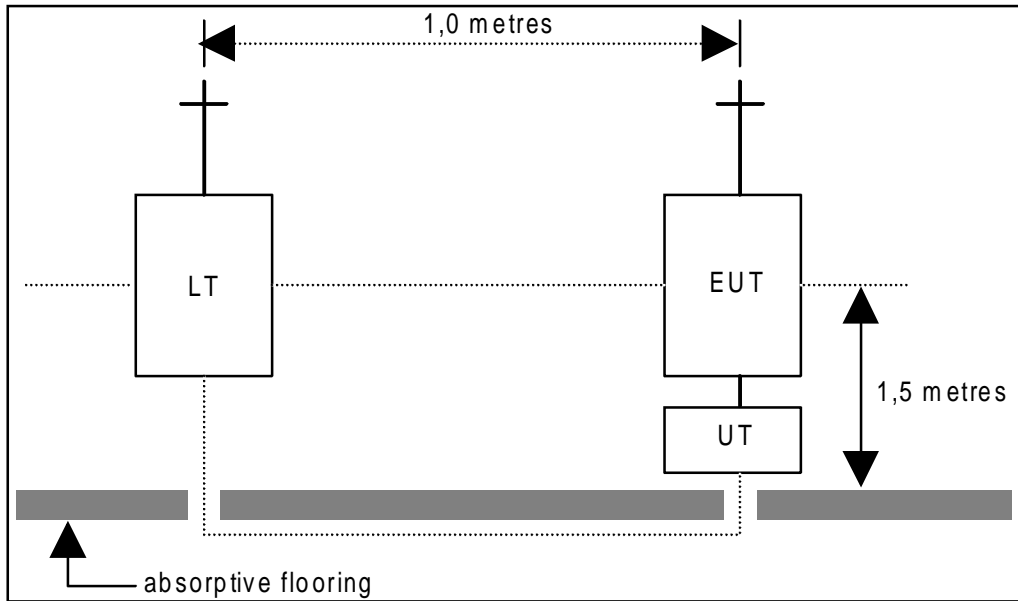

Figure 16

The elevation of the antennas are the same. Absorptive flooring is used to minimise reflection effects. The link between the UT and the EUT indicates the control of the EUT via the DECT air interface.

5.13.3 FT to PT arrangement

In the FT to PT situation, the minimum distance for non-interference operation is specified as being 1 m. Figure 17 shows the testing arrangement:

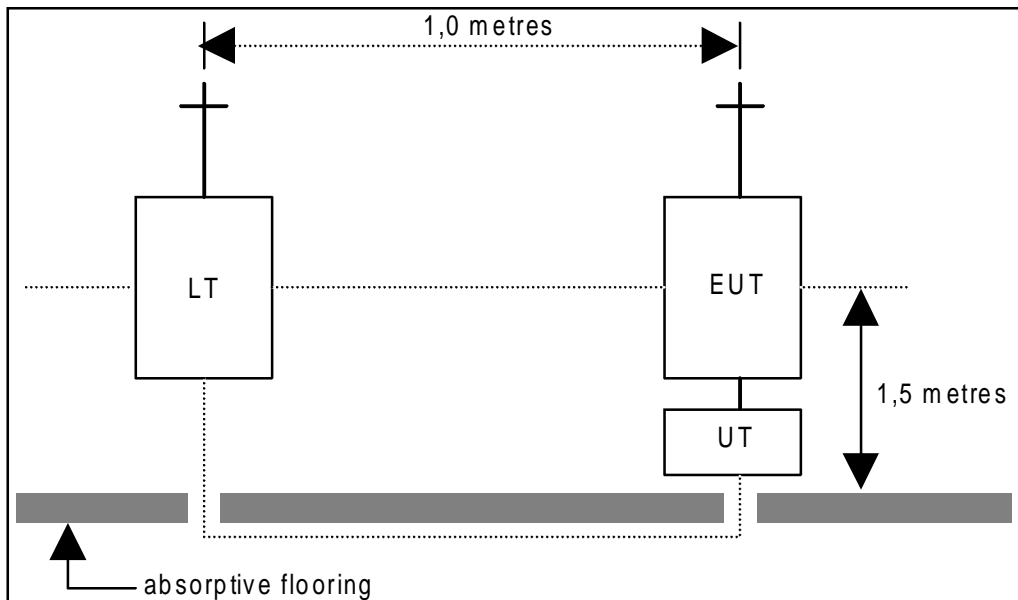

Figure 17

The elevation of the antennas are the same. Absorptive flooring is used to minimise reflection effects. The link between the UT and the EUT indicates the control of the EUT via the DECT air interface.

6 Test conditions, power sources and ambient temperatures

6.1 General

The following conditions shall apply during all tests:

atmospheric pressure: 86 to 106 kPa;
 Relative Humidity (RH): 5 % to 75 % non-condensing;

The temperature conditions and voltage supply applied in each test are specified as either nominal or extreme. The definitions of nominal and extreme are contained in subclauses 6.2 and 6.3. Each test case defines whether nominal or extreme conditions apply. In some test cases only extreme temperature conditions apply and this is stated in the appropriate test case.

Before measurements are made, the equipment shall have reached thermal equilibrium in the test chamber. The equipment shall be switched off during the temperature stabilizing period. If the thermal equilibrium is not checked by measurements, a temperature stabilizing period of at least one hour, or such period as may be decided by the test laboratory, shall be allowed.

Before the start of a test, but after reaching thermal equilibrium in the test chamber, the equipment shall be powered up. For RFPs, the time between power-up and the start of testing shall be greater than 15 minutes. For PPs, testing may commence any time after 1 minute after power-up.

The sequence of measurements shall be chosen, and the humidity content in the test chamber shall be controlled, so that condensation does not occur.

It is not necessary to control the atmospheric pressure during testing.

When it is impractical to carry out the tests under these conditions, a statement giving the actual temperature and relative humidity during the tests shall be recorded in the test report.

6.2 Nominal test conditions

These are identical for all types and classes of equipment. This is clarified by figures 18, 19 and 20.

PP:

	VOLTAGE		
	MIN	NOM	MAX
0°			
+ 15 - 35°			
+ 40°			

Figure 18

FP, RFP, CCFP for Class E1 use:

	VOLTAGE		
	MIN	NOM	MAX
+ 10°			
+ 15 - 35°			
+ 40°			

Figure 19

FP, RFP, CCFP for Class E2 use:

	VOLTAGE		
	MIN	NOM	MAX
- 10°			
+ 15 - 35°		■	
+ 55°			

Figure 20

For nominal temperature, each measurement is made at the temperature of the test site, which shall be within + 15 to + 35 °C.

6.3 Extreme test conditions

The extreme test conditions are determined by the type of equipment under test. Figures 21, 22 and 23 class the EUT as either PP, FP, RFP or CCFP (see subclause 3.2 for definitions).

In addition, FPs, RFPs and CCFPs shall be classed as either for Class E1 use or Class E2 use. Class E1 use refers to indoor areas allowing for personal comfort, for example, homes, offices, laboratories or workshops. Class E2 use refers to all other areas.

For the extreme temperature ranges of -10, 0, 10 and 40°C, measurements shall be made at the specified temperature with a tolerance of ± 1°C.

The definitions of minimum, nominal and maximum applied voltage are contained in subclauses 6.5 and 6.6.

PP:

	VOLTAGE		
	MIN	NOM	MAX
0°	■		■
+ 15 - 35°		■	
+ 40°	■		■

Figure 21

FP, RFP, CCFP for Class E1 use:

	VOLTAGE		
	MIN	NOM	MAX
+ 10°	■		■
+ 15 - 35°		■	
+ 40°	■		■

Figure 22

FP, RFP, CCFP for Class E2 use:

	VOLTAGE		
	MIN	NOM	MAX
- 10°	■		■
+ 15 - 35°		■	
+ 55°	■		■

Figure 23

6.4 Test power source - general requirements

During the type tests, the power source of the equipment shall be replaced by a test power source, capable of producing normal and extreme test voltages as specified in subclauses 6.5 and 6.6. The internal impedance of the test power source shall be low enough for its effect on the test results to be negligible. For the test purposes, the voltage of the power source shall be measured at the input terminals of the equipment.

If the equipment is provided with a permanently connected power cable, the test voltage shall be measured at the point of connection of the power cable to the equipment.

In equipment with incorporated batteries, the test power source shall be applied as close to the battery terminals as is practical. In each case connections shall be made readily available by the applicant.

During tests, the power source voltages shall be maintained within a tolerance of $\pm 3\%$ relative to the voltage at the beginning of each test.

6.5 Nominal test power source

6.5.1 Mains voltage

The normal test voltage for equipment to be connected to the mains shall be the nominal mains voltage. For the purpose of this ETS, the nominal voltage shall be the voltage or voltages for which the equipment was designed as declared by the applicant. The frequency of the test power source corresponding to the ac mains shall be between 49 and 51 Hz.

6.5.2 Regulated lead acid battery power sources

When the radio equipment is intended for operation from a lead-acid chemistry battery source, the source voltage used during testing shall be 1,1 times the nominal voltage of the battery (i.e. $1,1 \times \text{number of cells} \times 2 \text{ V/cell}$).

6.5.3 Nickel cadmium battery

When the equipment is intended for operation from a nickel-cadmium chemistry battery source, the source voltage used during testing shall be the nominal voltage of the battery ($1,2 \text{ V/cell}$).

6.5.4 Other power sources

For operation from other power sources or types of battery, either primary or secondary, the normal test source voltage shall be that declared by the applicant.

6.6 Extreme test power source

6.6.1 Mains voltage

The extreme test source voltages for equipment to be connected to an ac mains source shall be the nominal mains voltage $\pm 10\%$. The frequency of the test power source shall be between 49 and 51 Hz.

6.6.2 Regulated lead acid battery power sources

When the equipment is intended for operation from the usual type of regulated lead acid battery source, the extreme test voltages shall be 1,3 and 0,9 times the nominal voltage of the battery.

6.6.3 Nickel cadmium battery

When the equipment is intended for operation from the usual type of nickel cadmium battery, the extreme test voltages shall be 1,25 and 0,9 times the nominal voltage of the battery.

6.6.4 Other power sources

The lower extreme test voltage for equipment with power sources using primary batteries shall be as follows:

- a) for Leclanché type of battery: 0,85 times the nominal voltage;
- b) for other types of primary battery: the end point voltage declared by the applicant.

The upper extreme test voltage shall be the nominal voltage of the battery.

For equipment using other power sources, or capable of being operated from a variety of power sources, or designed for operation within extreme voltage limits not in accordance with those quoted above the extreme test voltages shall be those agreed between the applicant and the test laboratory and shall be recorded with the test results.

6.7 Testing of host connected equipment and plug-in cards

For equipment for which connection to or integration with host equipment is required to offer functionality, two alternative approaches are permitted. The applicant shall declare which alternative shall be used.

6.7.1 Alternative A: composite equipment

A combination of a DECT radio equipment part and a specific type of host equipment may be used for testing according to this ETS.

Where more than one such a combination is intended, each combination shall be tested separately.

In case a specific combination of host and DECT radio equipment part is tested as a composite system for type approval, it is expected that testing shall not be repeated for those other combinations of hosts and DECT radio equipment parts which are based on substantially similar host models on the condition that the variations in mechanical and electrical properties between such host models are unlikely to have any significantly different influence on the radio characteristics of the DECT radio equipment part and providing that the radio module cannot be used without electrical, mechanical or software modifications in variations of hosts different from those represented by the units used for the type examination.

6.7.2 Alternative B: use of a test jig and three hosts

Where the DECT radio equipment part is intended for use with a variety of host systems, the applicant shall supply a suitable test jig. The test jig shall be designed such that alteration of the DECT radio equipment's intrinsic emissions is minimized. Where connection between the DECT radio equipment part and the host is by means of cables, optical fibres or similar means between control and/or power ports, the connection to the host shall be considered a suitable test jig.

The test jig shall allow the DECT radio equipment part to be powered and stimulated in a way similar to the way it would be powered and stimulated when connected to or inserted into host equipment.

In addition to tests on the test jig, the DECT radio equipment part shall be tested according to subclauses 10.2, 12.2, 12.5.2 and 13.7 if the equipment is provided with an integral antenna, or subclauses 10.3, 12.2, 12.5.3 and 13.7 if the equipment is provided with an antenna connector; when connected to or inserted into three different hosts. These hosts shall be provided by the applicant and shall be selected from the list of compatible hosts as published by the applicant as part of the user documentation supplied with the radio equipment part. The selection of hosts shall be agreed to by the applicable authority. National regulatory administrations shall have the discretion to require the applicant to inform them of each deletion from or addition to the list of compatible hosts as published in the user documentation.

For those tests required by the previous paragraph, with the DECT radio equipment part to be connected to or inserted in host equipment, the combination shall be tested against the requirements except for cabinet radiation from the enclosure which only in these specific tests shall be measured according to the requirements that apply to the host equipment. When the host equipment is Information Technology Equipment (ITE), the requirements of EN 55022 [13], class B apply.

7 Accuracy and stability of RF carriers

The requirements are given in ETS 300 175-2 [2], subclause 4.1.2.

7.1 Definition

Ten RF carriers shall be placed into the frequency band 1 880 - 1 900 MHz with centre frequencies F_C given by:

$$F_C = F_0 - c \times 1,728 \text{ MHz};$$

where $F_0 = 1\,897,344 \text{ MHz}$
and $c = 0, 1, \dots, 9$.

Above this band, additional carriers are defined with centre frequencies F_C given by:

$$F_C = F_9 + c \times 1,728 \text{ MHz};$$

and $c \geq 10$ and RF band = 00001 (see ETS 300 175-3, subclause 7.2.3.3.1)

The frequency band between $F_C - 1,728/2 \text{ MHz}$ and $F_C + 1,728/2 \text{ MHz}$ shall be designated RF channel c .

NOTE: A nominal DECT RF carrier is one whose centre frequency is generated by the formula:

$$F_g = F_0 - g \times 1,728 \text{ MHz},$$

where g is any integer.

All DECT equipment shall be capable of working on all 10 RF channels, $c = 0, 1, \dots, 9$.

7.2 Test environment

The test shall take place at a test site or in a test fixture.

If the EUT has an antenna connector then it shall be used to connect the EUT to the LT.

The test shall take place under extreme test conditions.

7.3 Method of measurement

- a) The LT shall place the EUT in a mode whereby the EUT is positioned in a LT specified slot and RF channel $c = 5$. If so equipped, the handover function in the EUT shall be disabled (see subclause 5.9.3 for the appropriate test message reference).
- b) The EUT shall be placed in a test mode whereby it performs the loopback function as referenced in subclause 5.9.3.
- c) The LT shall transmit a packet with a test sequence in the loopback field of the packet. This test sequence shall be such that the sequence 0000 1111 0000 1111 is transmitted at the antenna of the EUT in the loopback field of the reply packet.
- d) Using the sampling method described in subclause 5.11.2.2, capture a representation of the EUT's transmitted RF signal after allowing the EUT to be in an active-locked state (see ETS 300 175-3 [3]) for more than 1 s.
- e) The EUT's carrier frequency for d) shall be assumed to be the average of the measured absolute frequencies of the loopback bits.

- f) Steps c) to e) shall be repeated until the following number of measurements have been made:

Equipment type	Number of measurements
A-field only transmit	100
Half-slot transmit	40
Full-slot transmit	10
Double-slot transmit	5

The centre frequency of the EUT is taken to be the mean value of the measurements.

- g) Steps c) to f) shall be repeated for all combinations of temperatures and power supply voltages allowed under extreme test conditions.
- h) Steps c) to g) shall be repeated for RF channels $c = 0$ and 9.
- i) When the EUT is a PP, then c) to h) shall be repeated, with the addition that the RF signal is sampled (in d)) during the first 1 s of the EUT going into a transmit mode from a non-transmitting mode. If necessary a) and b) may be repeated as required in order to make the number of measurements specified in f).

7.4 Verdict criteria when the EUT is a RFP

The carrier frequencies as measured shall be within ± 50 kHz of the appropriate nominal DECT carrier frequency F_C .

7.5 Verdict criteria when the EUT is a PP

7.5.1 Case 1: When the measurement is made during the first 1 s of the EUT going into a transmit mode from a non-transmitting mode

The carrier frequencies as measured either relative to an absolute frequency reference or relative to the received carrier, shall be within ± 100 kHz of the nominal DECT carrier frequency F_C .

7.5.2 Case 2: When the measurement is made at any other time

The carrier frequencies as measured either relative to an absolute frequency reference or relative to the received carrier, shall be within ± 50 kHz of the nominal DECT carrier frequency F_C .

8 Accuracy and stability of timing parameters

The requirements are given in ETS 300 175-2 [2], subclauses 4.2.2, 4.2.3 and 4.2.4.

8.1 Slot structure definitions

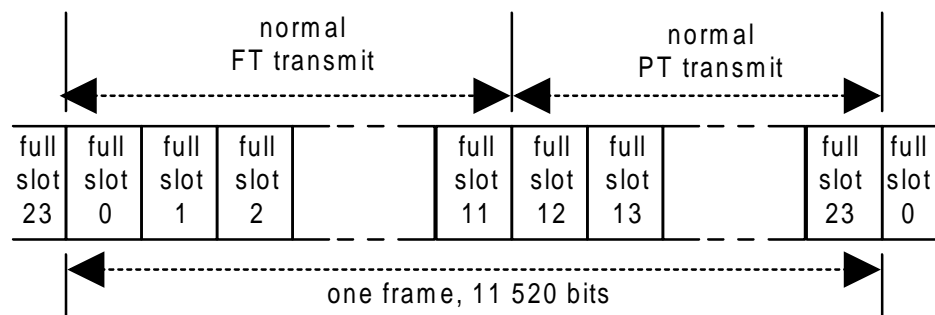

Figure 24: Frame and full-slot structure

Full-slots "K" are numbered from 0 to 23, and half-slots "L" are numbered 0 or 1, where half-slot 0 occurs earlier than half-slot 1. Normally full-slots $K = 0$ to 11 are used in the FT to PT direction, while full-slots $K = 12$ to 23 are normally used in the PT to FT direction.

Each full-slot has a duration of 480 bit intervals. Bit intervals within a full-slot are denoted f_0 to f_{479} where interval f_0 occurs earlier than interval f_1 . Each half-slot has a duration of 240 bit intervals. Half-slots commence at f_0 or f_{240} . See figure 25.

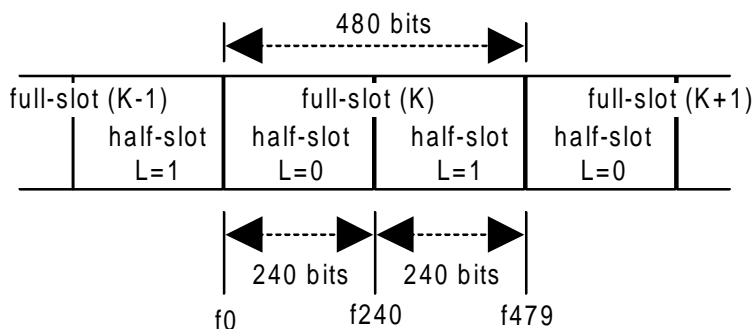

Figure 25: Half-slot format

Each double-slot has a duration of 960 bit intervals. Bit intervals within a double-slot are denoted f_0 to f_{959} . Bits f_0 to f_{479} coincide with the same notation for full-slots with even K , $K(e)$.

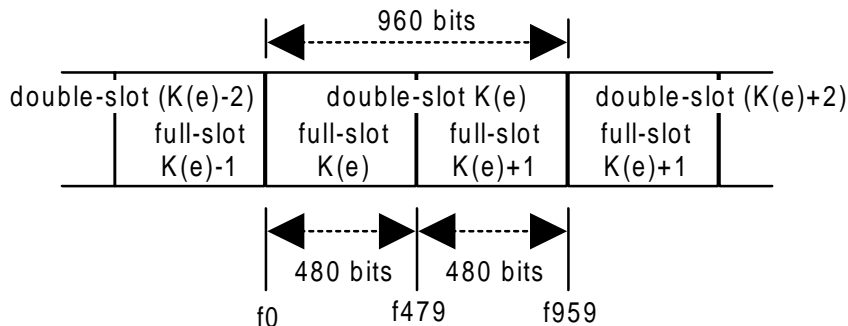

Figure 26: Double-slot format

8.2 Definition of the position of p_0

The start of bit p_0 is defined to occur at the point in time 16 bit periods before the instant at which the modulated carrier passes through the nominal channel frequency immediately prior to the deviation corresponding to the first bit of the packet synchronization word for the EUT as defined in ETS 300 175-2 [2], subclause 4.6, of for a PT or FT. A method shall be used for the determination of the position of the packet synchronization word which meets the measurement uncertainty stated in subclause 5.8.5. It is not the point at which a receiver determines the presence of p_0 .

8.3 Measurement of packet timing jitter

8.3.1 Test environment

The test shall take place at a test site in a test fixture. If the EUT is equipped with a temporary connector, the temporary connector may be used in place of the test fixture for this test.

If the EUT has an antenna connector then it shall be used to connect the EUT to the LT.

The test shall take place under extreme test conditions.

8.3.2 Method of measurement

- a) The LT shall place the EUT in a mode whereby the EUT is positioned in a LT specified slot and frequency. If so equipped, the handover function in the EUT shall be disabled (see subclause 5.9.3 for the appropriate test message reference).

The applicant shall declare to the testing laboratory the time required for system synchronization by the EUT.

- b) Using a sampling method, capture a representation of the RF signal transmitted by the EUT on the same slot position in 2 consecutive frames.
- c) The LT shall determine the positions of p0 in the slots that were sampled in part c) above.
- d) Steps b) and c) shall be repeated 1 000 times;
- e) The reference time is the mean of the values measured in c) through e). The deviation of the maximum and minimum values from the mean is the packet timing jitter.

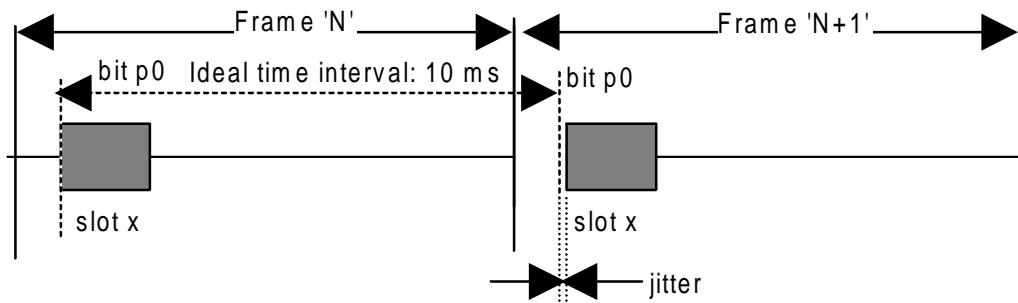

Figure 27

8.3.3 Verdict criteria

The packet timing jitter, as measured, shall be less than $\pm 1 \mu\text{s}$ for the duration of this test.

8.4 Measurement of the reference timing accuracy of a RFP

8.4.1 Test environment

The test shall take place at a test site or in a test fixture. If the EUT is equipped with a temporary connector, the temporary connector may be used in place of the test fixture for this test.

If the EUT has an antenna connector then it shall be used to connect the EUT to the LT.

The test shall take place under extreme test conditions.

8.4.2 Method of measurement

- a) A minimum of one duplex bearer shall be set-up between the LT and the EUT.
- b) Using a sampling method, measure the time, t_{long} , between the transmission of 1 000 frames using the same bit in each slot as the point of reference in each frame.

8.4.3 Verdict criteria

The EUT is required to conform to the following timing accuracy's and stability's at all the applied voltage conditions:

Table 4: Reference timing accuracy's and stability's

Type of EUT	Temperature	
	Nominal	Extreme
Multiple Channel RFP	5 ppm	10 ppm
Single Channel RFP	No test	10 ppm

t_{long} , as measured, shall be within the range of values given in table 5.

Table 5: Allowable timing variations

Timing Accuracy and Stability (ppm)	Ranges of t_{long} Constituting a Pass (seconds)
5	$9,99995 < t_{long} < 10,00005$
10	$9,99990 < t_{long} < 10,00010$

RFPs that can work with more than one duplex pair of physical channels per frame are known as multi-channel RFPs. Single channel RFPs can only work with one duplex pair of physical channels per frame (excluding handover situations).

8.5 Measurement of packet transmission accuracy of a PP

8.5.1 Test environment

The test shall take place at a test site or in a test fixture. If the EUT is equipped with a temporary connector, the temporary connector may be used in place of the test fixture for this test.

If the EUT has an antenna connector then it shall be used to connect the EUT to the LT.

If the EUT has the facilities for advancing the transmission timing from the nominal then this shall be disabled for the duration of this test.

The test shall take place under extreme test conditions.

8.5.2 Method of measurement

- a) The LT shall place the EUT in a mode whereby the EUT is positioned in a LT specified slot and channel number $c = 5$. If so equipped, the handover function in the EUT shall be disabled. See subclause 9.5.3 for the appropriate test message reference. The applicant shall declare to the testing laboratory the time required for a system synchronization by the EUT.
- b) Using a sampling method, capture a representation of the RF signal transmitted by the LT and EUT 12 slots apart in the same frame.
- c) The LT shall determine the positions at the EUT of p_0 in the slots that were sampled in part b) above.
- d) The delay shall be calculated as the difference in time between the p_0 of the LT and the p_0 of the EUT.
- e) Steps b) through to d) shall be repeated 100 times;
- f) Steps b) through to e) shall be repeated for RF channels $c = 0$ and 9.
- g) The minimum and maximum delays shall be found over all measurements.

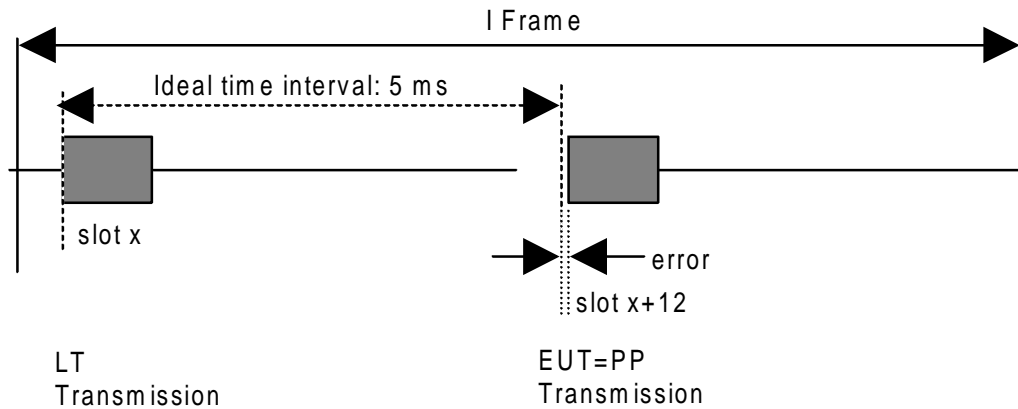

Figure 28

8.5.3 Verdict criteria

The packet timing delay minimum, as measured, shall be greater than $5\text{ ms} - 2\text{ }\mu\text{s}$, the maximum, as measured, shall be less than $5\text{ ms} + 2\text{ }\mu\text{s}$.

9 Transmission burst

The requirements are given in subclause 5.2 of ETS 300 175-2 [2].

9.1 Definitions

9.1.1 Physical packets

The term "physical packet" used in this ETS refers to all the bits transmitted by the DECT REP in one slot time. The timing of the physical packet relative to the power-time template shall be conditioned by the absolute packet timing measurement uncertainty in subclause 5.8.5.

9.1.2 Transmitted power

This is the mean power delivered over one radio frequency cycle.

9.1.3 Normal Transmitted Power (NTP)

The NTP is the transmitted power averaged from the start of bit p0 of the physical packet to the end of the physical packet.

9.1.4 Transmitter attack time

This is the time taken for the transmitted power to increase from $25\text{ }\mu\text{W}$ to the time that the first bit of the physical packet, p0, starts transmission.

The transmitter attack time shall be less than $10\text{ }\mu\text{s}$.

9.1.5 Transmitter release time

This is the time, taken from the end of the physical packet, for the transmitted power to decrease to $25\text{ }\mu\text{W}$.

The transmitter release time shall be less than $10\text{ }\mu\text{s}$.

9.1.6 Minimum power

From the first bit of the packet, p0, to the end of the physical packet, the transmitted power as measured shall be greater than (NTP - 1 dB).

9.1.7 Maximum power

From 10 μ s after the start of bit p0 to 10 μ s after the end of the physical packet the transmitted power as measured shall be less than (NTP + 1 dB).

From 10 μ s before the start of bit p0 to 10 μ s after the start of bit p0 the transmitted power as measured shall be less than (NTP + 4 dB), and shall be less than 315 mW plus the maximum allowed measurement uncertainty as described in subclause 5.8.5.

9.1.8 Maintenance of transmission after packet end

The transmitted power as measured shall be maintained greater than (NTP - 6 dB) for 0,5 μ s after the end of the physical packet.

9.1.9 Transmitter idle power output

For the time period starting 27 μ s after the end of the physical packet, and finishing 27 μ s before the next transmission of data bit p0, the transmitter idle power shall be less than 20 nW plus the maximum allowed measurement uncertainty as described in subclause 5.8.5. This requirement shall apply except when p0 of the next transmitted packet occurs less than 54 μ s after the end of the transmitted physical packet.

9.2 Test environment

If the EUT has an antenna connector then it shall be used to connect the EUT to the LT.

The test shall take place under nominal and extreme temperature conditions at the nominal supply voltage.

This test shall take place either at a test site, in an anechoic chamber, or in a test fixture for the nominal temperature condition. The extreme temperature testing shall take place inside a temperature chamber with the EUT mounted in a test fixture.

9.3 Method of measurement

- a) The LT shall place the EUT in a mode whereby the EUT is transmitting at a LT specified slot and RF channel $c = 5$. If so equipped, the handover function in the EUT shall be disabled (see subclause 5.9.3 for the appropriate test message reference).
- b) Using a sampling measurement method, capture a representation of the EUT's transmit burst's amplitude and modulation. The measurement bandwidth for RF power shall be 1 MHz for the measurement of transmitter idle power (see subclause 9.1.9) and ≥ 3 MHz for all other.
- c) From the array of samples the LT shall calculate the position of bit p0 and the end of the physical packet in each sample to an accuracy of 0,1 μ s;
- d) Steps b) and c) are repeated 60 times with intervals of 1 s or longer;
- e) Steps a) to d) shall be repeated for RF channels $c = 0$ and 9.

9.4 Verdict criteria

The array of power samples shall be compared for a fit within the power-time template as shown in figure 29 and shall comply with the requirements in subclauses 9.1.4, 9.1.5, 9.1.6, 9.1.7, 9.1.8 and 9.1.9.

The sampled bursts, as measured, shall conform to the power-time template.

NOTE: As described in subclause 9.1.9, the 20 nW power envelope shown in figure 29 is only applicable when the time between the end of a physical packet and the transmission of p0 of the next physical packet is greater than 54 μs.

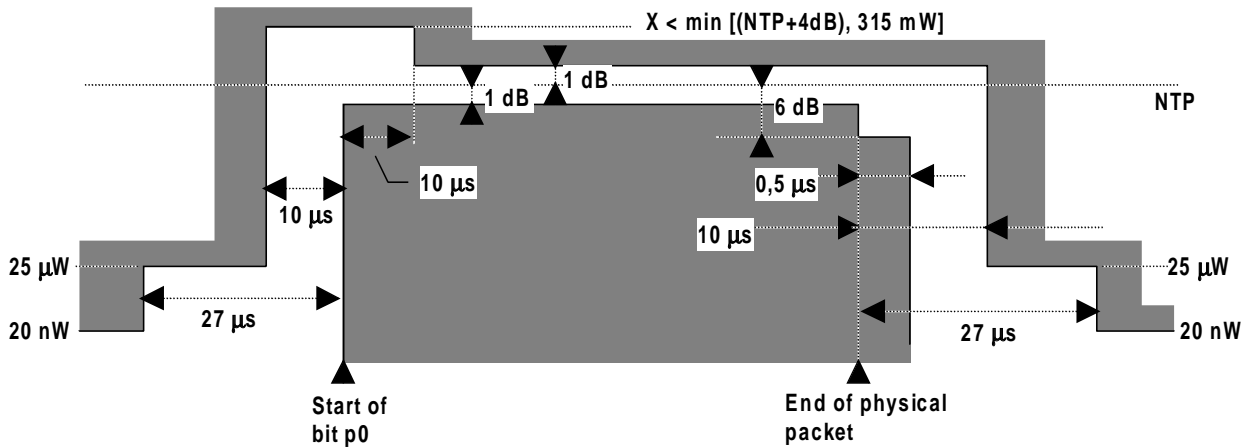

Figure 29: Power-time template

For packets with prolonged preamble, the verdict criteria apply with the notation p0 generally changed to p-16 and the applicant shall declare that the procedure defined in ETS 300 175-2 [2], clause D.3 has been implemented.

10 Transmitted power

The requirements are given in ETS 300 175-2 [2], subclause 5.3.

10.1 Definitions

10.1.1 PP and RFP with an integral antenna

The NTP shall be less than P_{NTP} per simultaneously active transceiver at nominal conditions.

The transmitter power P_{NTP} is defined in subclause 5.3 of ETS 300 175-2 [2].

10.1.2 PP and RFP with external connections for all antennas

For a radio end point with more than one antenna port, the instantaneous power from each antenna port shall be added together to give the NTP.

The NTP shall be less than P_{NTP} per simultaneously active transceiver.

The transmitter power P_{NTP} is defined in table 6.

Table 6

Power Level	P_{NTP} (mW)
Level 1	2,5
Level 2	250

The maximum transmitter power P_{NTP} shall be no higher than Level 2.

All equipment shall be capable of working at power level 2. The default power level for the PP shall be level 2. It is recommended that the RFP indicates to the PP a power level to match the RFP operation.

If the PP is capable of operating at levels other than level 2, then it shall be capable of interpreting the P_T MAC information message "recommended PP power level" (See ETS 300 175-3: "Medium access control layer", section 7.2.4.3.11) and shall operate at the recommended power level if it is capable of doing so. Otherwise the PP should operate at the default power level.

10.1.3 PP and RFP with both integral and external antennas

If the integral and external antennas are not transmitting simultaneously then the test cases described in subclauses 10.2 and 10.3 shall be applied independently. The appropriate antenna is selected using the test message referenced in subclause 5.9.3.

If the integral and external antennas are transmitting simultaneously then both subclauses 10.2 and 10.3 shall be applied and the results shall be added to give the NTP.

10.2 PP and RFP with an integral antenna

10.2.1 Test environment

The test shall take place under nominal temperature conditions and at a nominal supply voltage.

This test shall take place either at a test site or in an anechoic chamber for the nominal temperature condition.

10.2.2 Method of measurement

The test consists of both a conducted and a radiated power measurement. For the conducted power measurement, the EUT shall be equipped with a temporary antenna connector. The radiated measurement is performed on a EUT with its own integral antenna.

10.2.2.1 Measurement of NTP

The test described in 10.3.2 shall be performed on the EUT with the temporary connector.

The measured result is the NTP.

10.2.2.2 Measurement of antenna gain

The following measurement is done on the EUT with its own integral antenna:

- a) if the EUT incorporates antenna diversity, then the LT shall command the EUT to operate on a single antenna (see subclause 5.9.3 for the appropriate test message reference);
- b) the LT shall place the EUT in a mode whereby the EUT is positioned in a LT specified slot and frequency. If so equipped, the handover function in the EUT shall be disabled (see subclause 5.9.3 for the appropriate test message reference);
- c) a test antenna with a good directivity to limit reflections is connected to a calibrated receiver. The applicant shall indicate the polarization of the integral antenna so that the test antenna can be set to the same polarization as the integral antenna of the EUT throughout this test. The test antenna shall be raised or lowered until a maximum received signal is obtained, except when using a fully anechoic chamber.

The EUT shall be orientated in the reference position using the procedure described in subclause 5.11.3;

- d) at this position, the LT shall:
 - 1) use the sampling method described in subclause 5.11.2.2 to capture a representation of a physical packet transmitted by the EUT;
 - 2) determine the position of p0 in the physical packet and the end of the physical packet;
 - 3) make a measurement of the received power over the 1 MHz bandwidth centred on the DECT RF channel. This power shall be averaged from the start of bit p0 to the end of the physical packet. This measurement shall be called P_R ;
- e) the substitution antenna shall replace the EUT's transmitter antenna in the same position and polarization. The frequency of the signal generator shall be adjusted to the EUT's nominal channel frequency on which it was transmitting. The test antenna shall be raised or lowered as necessary to ensure that the maximum signal level is received, except when using a fully anechoic chamber. The input signal level to the substitution antenna shall be adjusted until an equal or a known related level to P_R is obtained in the test receiver.

P_T is equal to the power supplied by the signal generator, increased by the known related level if necessary and after corrections due to the gain of the substitution antenna and the cable loss between the signal generator and the substitution antenna;

- f) the antenna gain is the ratio (in dB) between the radiated power P_T and the NTP;
- g) steps b) to f) shall be performed for RF channels $c = 0, 5, \text{ and } 9$.

10.2.3 Verdict criteria for all EUTs

The NTP per simultaneously active transceiver, as measured, shall be less than P_{NTP} plus the maximum allowable measurement uncertainty for absolute RF power (via an antenna connector) as given in subclause 5.8.5.

The antenna gain as measured shall be less than ± 12 dB plus the maximum allowable measurement uncertainty for absolute RF power (radiated) as given in subclause 5.8.5.



10.3 PP and RFP with external antenna connection(s)

10.3.1 Test environment

The test shall take place under extreme temperature conditions and at a nominal supply voltage.

This test shall take place either at a test site or in an anechoic chamber for the nominal temperature condition. The extreme temperature testing shall take place inside a temperature chamber.

The EUT shall be connected to the LT via the antenna connector(s).

10.3.2 Method of measurement

- a) If the EUT incorporates antenna diversity, then the LT shall command the EUT to operate on a single external antenna (see subclause 5.9.3 for the appropriate test message reference).
- b) The LT shall place the EUT in a mode whereby the EUT is positioned in a LT specified slot and frequency. If so equipped, the handover function in the EUT shall be disabled (see subclause 5.9.3 for the appropriate test message reference).
- c) A test load shall be connected to each antenna connector.
- d) The LT shall:
 - 1) use the sampling method described in subclause 5.11.2.2 to capture a representation of a physical packet transmitted by one of the antenna connectors of the EUT into the test load;
 - 2) determine the position of p0 in the physical packet and the end of the physical packet;
 - 3) make a measurement of the power over the 1 MHz bandwidth centred on the DECT RF channel. This power shall be the power delivered to each load simultaneously, averaging from the start of bit p0 of the physical packet, to the end of the physical packet that was sampled in 1).
- e) Steps b) to d) shall be performed for RF channels $c = 0, 5, \text{ and } 9$.

When there is more than one antenna port, the instantaneous power from each antenna port shall be added together. The sum shall be called the NTP.

10.3.3 Verdict criteria for all EUTs

The NTP per simultaneously active transceiver, as measured, shall be less than P_{NTP} plus the maximum allowable measurement uncertainty as given in subclause 5.8.5.

11 RF carrier modulation

The requirements are given in ETS 300 175-2 [2], subclause 5.4.

11.1 Test environment

The test should preferably take place at a test site, otherwise a test fixture or temporary connector shall be used.

If the EUT has an antenna connector then it shall be used to connect the EUT to the LT.

The test shall take place under nominal supply voltage conditions and at a nominal temperature.

11.2 Method of measurement, Parts 1 and 2

The measurement period of a single positive or negative deviation measurement shall begin one bit time after a 0 to 1 or a 1 to 0 transition in the test data pattern. The measurement period shall end one bit time before the next 0 to 1 or 1 to 0 transition.

11.2.1 Part 1

- a) Repeat parts a) to d) of subclause 7.3.
- b) Using the samples that were obtained from a), the LT shall calculate the peak frequency deviation within each bit period defined in subclause 11.2 in the loopback field of the transmit burst of the EUT, relative to the measured carrier frequency that was calculated in clause 7. The measurement bandwidth shall be ≥ 3 MHz.
- c) Steps a) to b) shall be repeated until the following number of measurements have been made:

Equipment type	Number of measurements
A-field only transmit	100
Half-slot transmit	40
Full-slot transmit	10
Double-slot transmit	5

11.2.2 Part 2

- a) Steps a) to d) of subclause 7.3 shall then be repeated using the appropriate sequence listed below:

Equipment type	Test pattern
A-field only transmit	Figure 30
Half-slot transmit	Figure 31
Full-slot transmit	Figure 32
Double-slot	Figure 33

- b) Using the samples that were obtained from part (a) above, the LT shall calculate the peak frequency deviation within each bit period defined in subclause 11.2 in the loopback field of the transmit burst of the EUT, relative to the measured carrier frequency that was calculated in clause 7. The measurement bandwidth shall be ≥ 3 MHz.
- c) Steps a) to b) shall be repeated until the following number of measurements have been made:

Equipment type	Number of measurements
A-field only transmit	100
Half-slot transmit	40
Full-slot transmit	10
Double-slot transmit	5

11.3 Method of measurement, Parts 3 and 4

The measurement period for the deviation measurement shall begin one bit time after the first 0 to 1 or 1 to 0 transition. The measurement period shall end one bit time before the last 0 to 1 or 1 to 0 transition.

11.3.1 Part 3

- a) Steps a) to d) of subclause 7.3 shall be repeated with the sequence "0101 0101 0101 0101".
- b) using the samples that were obtained from part a) above, the LT shall calculate the peak frequency deviation within each bit period in the first 16 bits of the synchronization field (preamble) and the loopback field of the transmit burst of the EUT, relative to the measured carrier frequency that was calculated in clause 7. The measurement bandwidth shall be ≥ 3 MHz.
- c) Steps a) to b) shall be repeated until the following number of measurements have been made:

Equipment type	Number of measurements
A-field only transmit	100
Half-slot transmit	40
Full-slot transmit	10
Double-slot transmit	5

11.3.2 Part 4

- a) The LT shall place the EUT in a mode whereby the EUT is positioned in a LT specified slot and frequency. If so equipped, the handover function in the EUT shall be disabled (see subclause 5.9.3 for the appropriate test message reference).
- b) The EUT shall be placed in a test mode whereby it performs the loopback function as referenced in subclause 5.9.3.
- c) The LT shall transmit a packet with a test sequence in the loopback field of the packet. This test sequence shall be such that the sequence 0101 0101 0101 0101 is transmitted at the antenna of the EUT in the loopback field of the reply packet.
- d) Using the sampling method described in subclause 5.11.2.2 capture a representation of the EUT's transmitted RF signal after allowing the EUT to be in an Active-locked state (see ETS 300 175-3 [3]) for more than 1 s. The measurement bandwidth shall be ≥ 3 MHz.
- e) Using the samples that were obtained from d) above, the LT shall calculate the average frequency of the last 14 bits of the first 16 bits of the synchronization field.
- f) Using the samples that were obtained from d) above, the LT shall calculate the average frequency of the first 14 bits of the last 16 bits of the loopback field.
- g) Steps c) to f) shall be repeated until 200 measurements have been made. The frequency drift is the difference between the mean of the measurements taken in e) and the mean of the measurements taken in f).

11.4 Verdict criteria for Part 1

The peak frequency deviation as measured in Part 1 shall be greater than ± 259 kHz and less than ± 403 kHz.

11.5 Verdict criteria for Part 2

The peak frequency deviation as measured in Part 2 shall be greater than ± 202 kHz and less than ± 403 kHz.

11.6 Verdict criteria for Part 3

The peak frequency deviation as measured in Part 3 shall be greater than ± 202 kHz and less than ± 403 kHz.

11.7 Verdict criteria for Part 4

The rate of change as measured in Part 4 shall not be greater than 15 kHz per slot plus the maximum measurement uncertainty calculated from the allowable uncertainty in the relative drift radio frequency measurements involved (see subclause 5.8.5). This implies that the drift in slot shall be between -17 kHz per slot and +17 kHz per slot, as measured.

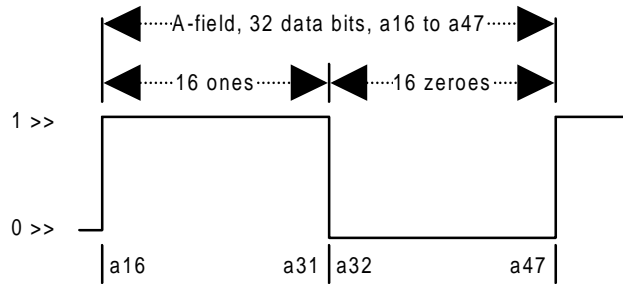
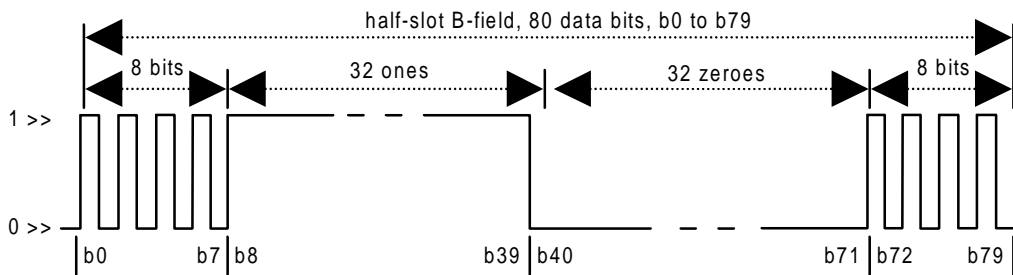
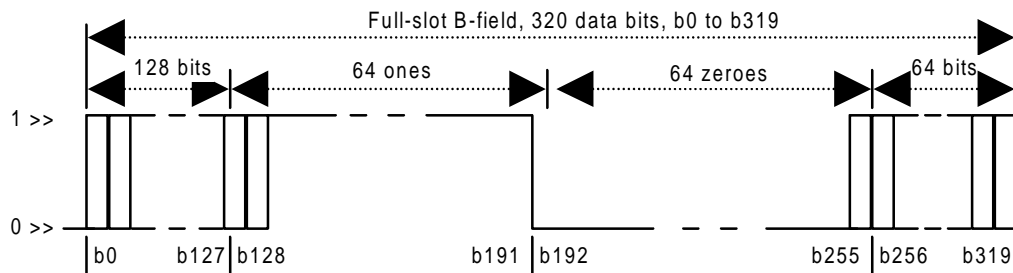

Figure 30: Test packet structure for Case 2, A-field



NOTE 1: Bits b_0 to b_7 and b_{72} to b_{79} are alternating 1s and 0s with the even order bits (b_0, b_2, b_4, \dots) set to '1' and the odd-order bits (b_1, b_3, b_5, \dots) set to '0'.

Figure 31: Test packet structure for case 2, half-slot



NOTE 2: Bits b_0 to b_{127} and b_{256} to b_{319} are alternating 1s and 0s.

Figure 32: Test packet transmission for case 2, full-slot

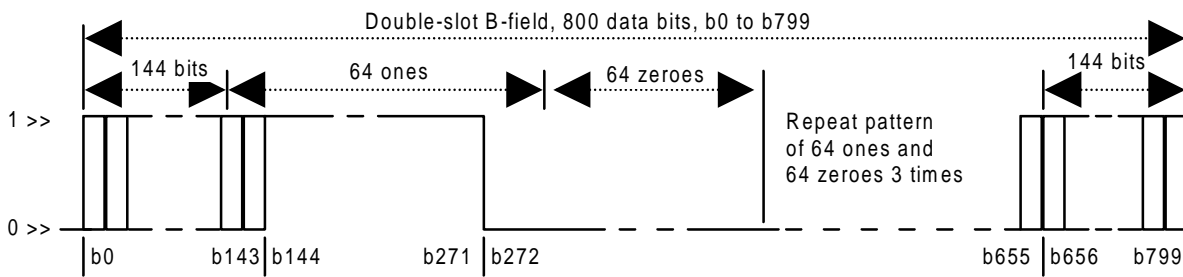

NOTE 3: Bits b_0 to b_{143} and b_{656} to b_{799} are alternating 1s and 0s.

Figure 33: Test packet transmission for case 2, double-slot

NOTE 4: The above fields, (A-field for figure 30, half-slot for figure 31, full-slot for figure 32, and double-slot for figure 33) are defined in ETS 300 175-3 [3]. The X-field portions of the half-slot, full-slot, and double-slot B-fields depicted in figures 31, 32, and 33 are not shown.

12 Unwanted RF power radiation

12.1 General test conditions

If the EUT is equipped with antenna diversity, the EUT shall have the diversity operation defeated for the following tests, (see subclause 5.9.3 for the appropriate test message reference).

12.2 Emissions due to modulation

The requirements are given in ETS 300 175-2 [2], subclause 5.5.1.

12.2.1 Definition

The unwanted emission(s) due to modulation is the power measured in any DECT RF channel other than the one in which the EUT is transmitting, integrated over a bandwidth of 1 MHz.

12.2.2 Test environment

The test shall take place at a test site or using a test fixture for equipment with integral antenna.

The test shall take place under nominal supply voltage conditions and at a nominal temperature.

12.2.3 Method of measurement

- a) If the EUT has an external antenna connector then this shall be used to connect the EUT to the LT. Otherwise, the transmitted signal shall be applied to the LT via a coupling device which provides the appropriate signal level to the system. The analysing system in the LT shall be operated under the following conditions:

frequency sweep:	1 MHz;
resolution bandwidth:	100 kHz;
video bandwidth:	greater than resolution bandwidth;
integration:	across the frequency sweep;
peak hold:	on;
sweep time:	greater than 12 seconds;
filtering type:	synchronously tuned.

The centre frequencies of the DECT RF channels are defined in subclause 7.1.

The total sample time used for measurement is 60 % to 80 % of the duration of the physical packet, starting before 25 % of the slot time has expired but after the transmission of the synchronization word. The LT shall determine the start of the physical packet (bit p_0) transmitted by the EUT.

- b) The LT shall place the EUT in a mode whereby the EUT is positioned in a LT specified slot and frequency. If so equipped, the handover function in the EUT shall be disabled. See subclause 5.9.3 for the appropriate test message reference.
- c) The EUT shall be placed in a test mode whereby it performs the loopback function as referenced in subclause 5.9.3.
- d) A test modulation signal D-M2 (see subclause 5.8.4.4) is generated by the LT.
- e) Using the analysing system, a measurement of the EUT's transmitted power on channel M is made during the sampling time. This power measurement shall be called P_{ref} .

NOTE: This measurement becomes the reference power for the power measurements of the other channels.

- f) Using the method described in e), a measurement on all the other DECT channels shall be made and recorded in dB as a value relative to P_{ref} . These shall be called P_{rm-2} , P_{rm-1} , P_{rm+1} , P_{rm+2} , etc., corresponding to the measurements made on channels $Y = M-2$, $Y = M-1$, $Y = M+1$ and $Y = M+2$.
- g) Using the measured value of transmitted power, NTP, from clause 10 for channel $Y = M$, the LT shall calculate the power emissions on each channel.

EXAMPLE: Emissions on channel $Y = M + 1$:

$$= NTP(\text{dBm}) + P_{rm+1}(\text{dB}).$$

- h) The value calculated in g) shall be converted from dBm to Watts.
- i) Steps b) through h) shall be performed with the EUT's transmitter placed on DECT RF channels $c = 0, 5, \text{ and } 9$.

12.2.4 Verdict criteria

The unwanted emissions, as measured, shall not be greater than the power levels stated in table 7.

Table 7

Emissions on RF Channel "Y"	Maximum Power Level
$Y = M \pm 1$	160 μW
$Y = M \pm 2$	1 μW
$Y = M \pm 3$	40 nW
Y = any other DECT channel	20 nW

For $Y = \text{"any other DECT channel"}$, the maximum power level shall be less than 40 nW except for one instance per M of a 500 nW signal.

"M" is the EUT transmit channel and "Y" is a legal DECT channel other than the EUT transmit channel.

12.3 Emissions due to transmitter transients

The requirements are given in ETS 300 175-2 [2], subclause 5.5.2.

12.3.1 Definition

The power level of all modulation products (including AM components due to the switching on or off of the modulated RF carrier) in a DECT RF channel as a result of a transmission on another DECT RF channel.

12.3.2 Test environment

The test shall take place at a test site or using a test fixture for equipment with integral antenna.

The test shall take place under nominal supply voltage conditions and at a nominal temperature.

12.3.3 Method of measurement

- a) If the EUT has an external antenna connector then this shall be used to connect the EUT to the LT. Otherwise, the transmitted signal shall be applied to the LT via a coupling device which provides the appropriate signal level to the system. The analysing system in the LT shall be operated under the following conditions:

frequency sweep:	1 MHz;
resolution bandwidth:	100 kHz;
video bandwidth:	greater than resolution bandwidth;
averaging:	none;
peak hold:	on;
filtering type:	4 or 5 pole synchronously tuned.

The centre frequencies of the DECT RF channels are defined in subclause 7.1.

- b) The LT shall place the EUT in a mode whereby the EUT is positioned in a LT specified slot and frequency. If so equipped, the handover function in the EUT shall be disabled (see subclause 5.9.3 for the appropriate test message reference).
- c) The EUT shall be placed in a test mode whereby it performs the loopback function as referenced in subclause 5.9.3.
- d) A test modulation signal D-M2 (see subclause 5.8.4.4) generated by the LT.
- e) The analysing system centre frequency is positioned at the centre of the DECT RF channel being measured.
- f) The analysing system shall initiate a power measurement procedure conforming to the limits specified in subclause 5.8.5.
- g) Using the measured values obtained from e) to f), the LT shall select the highest recorded value within the sweep. This value shall be compared with the verdict criteria.
- h) Steps e) to g) are repeated for all DECT RF channels other than the one on which the EUT is transmitting;
- i) Steps b) to h) shall then be repeated until measurements have been made with the EUT's transmitter placed on all 10 DECT RF channels.

12.3.4 Verdict criteria

The unwanted emissions, as measured, shall not be greater than the power levels stated in table 8.

Table 8

Emissions on RF Channel "Y"	maximum peak power Level
Y = M ± 1	250 μW
Y = M ± 2	40 μW
Y = M ± 3	4 μW
Y = any other DECT channel	1 μW

"M" is the EUT transmit channel and "Y" is a legal DECT channel other than the EUT transmit channel.

12.4 Emissions due to intermodulation

The requirements are given in ETS 300 175-2 [2], subclause 5.5.3.

12.4.1 Definition

The power level of intermodulation products that are on any DECT physical channel when any combination of the transmitters at a radio FP or portable part are in calls on the same slot on different frequencies.

12.4.2 Test environment

If the EUT is a PP equipped with an integral antenna, the EUT and the test antenna shall be mounted in the reference test arrangement as specified in subclause 5.13.1.

If the EUT is a RFP with an integral antenna, the EUT and the test antenna shall be mounted in the reference testing arrangement as specified in subclause 5.13.2.

If the EUT has an external antenna connector then this test shall preferably take place at a test site, otherwise a test fixture may be used.

The test shall take place under nominal supply voltage conditions and at a nominal temperature.

12.4.3 Method of measurement

- a) If the EUT has an external antenna connector then this shall be used to connect the EUT to the LT. Otherwise, the transmitted signal shall be applied to the LT via a coupling device which provides the appropriate signal level to the system. The analysing system in the LT shall be operated under the following conditions:
- frequency sweep: 1 MHz;
 - resolution bandwidth: 100 kHz;
 - video bandwidth: greater than resolution bandwidth;
 - integration: across the frequency sweep;
 - peak hold: on;
 - sweep time: greater than 12 seconds;
 - filtering type: synchronously tuned.

The centre frequencies of the DECT RF channels are defined in subclause 7.1.

The total sample time used for measurement is 60 % to 80 % of the duration of the physical packet, starting before 25 % of the slot time has expired but after the transmission of the synchronization word. The LT shall determine the start of the physical packet (bit p0) transmitted by the EUT.

- b) The EUT shall be placed in a mode whereby two of the transceivers shall be made to operate on the same slot in the frame but on different DECT RF channels. The RF channels shall be $c = 0$ and $c = 9$. If so equipped, the handover function in the EUT shall be disabled (see subclause 5.9.3 for the appropriate test message reference).
- c) The EUT shall be placed in a test mode whereby it performs the loopback function for both transceivers as referenced in subclause 5.9.3.
- d) A test modulation signal D-M2 (see subclause 5.8.4.4) is generated by the LT.
- e) Using the analysing system, a measurement of the transmitted powers on channels $M = 0$ and $M = 9$ shall be made during the sample time for a transmitter in the EUT. These measurements shall be called P_{ref0} and P_{ref9} .
- f) The EUT shall be placed in a mode whereby two of the transmitters shall be made to operate on the same slot in the frame but on different DECT RF channels. The RF channels shall be $M = 3$ and $M = 6$. If so equipped, the handover function in the EUT shall be disabled (see subclause 5.9.3 for the appropriate test message reference).
- g) Using the analysing system, a measurement of the power levels on channels $c = 0$ and $c = 9$ shall be made during the sample time for a transmitter in the EUT. These power measurements shall be called P_{m0} and P_{m9} .
- h) Using the NTPs for $c = 0$ and $c = 9$ (as defined in clause 10), the LT shall calculate the power emissions on channels $c = 0$ and $c = 9$. The calculation shall be performed as follows:
- 1) emissions on channel 0:

$$= NTP_0(\text{dBm}) - P_{ref0}(\text{dBm}) + P_{m0}(\text{dBm});$$
 - 2) emissions on channel 9:

$$= NTP_9(\text{dBm}) - P_{ref9}(\text{dBm}) + P_{m9}(\text{dBm}).$$
- i) Steps b) to h) shall be repeated until measurements have been made with all combinations of the EUT's transmitters.

12.4.4 Verdict criteria

The unwanted emissions due to intermodulation as measured shall not be greater than $1 \mu\text{W}$ in the measurement channels.

12.5 Spurious emissions when allocated a transmit channel

The requirements are given in ETS 300 175-2 [2], subclause 5.5.4.

12.5.1 Definition

The peak power level of any RF emissions outside the radio frequency band allocated to DECT when a radio endpoint has been allocated a transmit channel. If a REP has more than one transceiver, any out of band transmitter intermodulation products shall also be included.

12.5.2 Radiated emissions

12.5.2.1 Test environment

The test shall take place at a test site.

For EUTs with external antenna connectors, test loads shall be attached to each connector.

The test shall take place under nominal supply voltage conditions and at a nominal temperature.

12.5.2.2 Method of measurement

a) The analysing system in the LT shall be operated under the following conditions:

- frequency sweep: as required for frequency range;
- resolution bandwidth: refer to table 9;
- display bandwidth: greater than resolution bandwidth;
- averaging: refer to table 9;
- peak hold: refer to table 9;
- filtering type: synchronously tuned.

The sweep time shall be chosen to be slow enough to ensure that the LT is capable of capturing at least one burst spurious signal for every measurement point.

NOTE: This may be achieved by using the following formula:

$$\text{sweep time} > \frac{2 \times (\text{PRI} \times \text{frequency span})}{\text{resolution bandwidth}} \quad (2)$$

where PRI = pulse repetition interval = 10 ms.

Table 9

Frequency offset from edge of band	Resolution Bandwidth	Peak Hold	Averaging
0 to 2 MHz	30 kHz	on	none
2 to 5 MHz	30 kHz	on	none
5 to 10 MHz	100 kHz	on	none
10 to 20 MHz	300 kHz	on	none
20 to 30 MHz	1 MHz	on	none
30 to 4000 MHz	3 MHz	on	none

NOTE: The highest frequency of measurement should not exceed 4 GHz for radiated measurements.

Measurements shall not be made for transmissions on the RF channel closest to the nearest band edge for frequency offsets of up to 2 MHz.

The centre frequencies of the DECT RF channels are defined in subclause 7.1.

- b) The LT shall place the EUT in a mode whereby the EUT is positioned in a LT specified slot and frequency. If so equipped, the handover function in the EUT shall be disabled (see subclause 5.9.3 for the appropriate test message reference).
- c) The EUT shall be placed in a test mode whereby it performs the loopback function as referenced in subclause 5.9.3.
- d) A test modulation signal D-M2 (see subclause 5.8.4.4) is generated by the LT.

- e) The LT shall initiate a power measurement procedure conforming to the limits specified in subclause 5.8.5 using the methods described in annex B.
- f) The test shall be carried out over the RF ranges from 30 MHz to 4 GHz and the power measurements shall be performed using the resolution bandwidth as indicated in table 9.

12.5.2.3 Verdict criteria

The spurious emissions, as measured, shall not be greater than 250 nW at frequencies below 1 GHz and 1 μ W at frequencies above 1 GHz.

In addition, not regarding up to 2 instances of a continuous-wave spurious signal for PPs for which the total peak power level shall be less than 250 nW as measured in a 3 MHz measurement bandwidth, the peak power level shall be less than 20 nW in a 100 kHz measuring bandwidth for the following broadcast bands:

47 - 74 MHz;
87,5 - 108 MHz;
108 - 118 MHz;
174 - 230 MHz;
470 - 862 MHz.

12.5.3 Conducted spurious emissions

12.5.3.1 Test environment

The test shall take place under nominal supply voltage conditions and at a nominal temperature.

12.5.3.2 Method of measurement

- a) The EUT shall be connected to the LT via the external antenna connector. The external antenna connector may either be temporary or permanent.

Table 10

Frequency offset from edge of band	Resolution Bandwidth	Peak Hold	Averaging
0 to 2 MHz	30 kHz	on	none
2 to 5 MHz	30 kHz	on	none
5 to 10 MHz	100 kHz	on	none
10 to 20 MHz	300 kHz	on	none
20 to 30 MHz	1 MHz	on	none
30 to 12 750 MHz	3 MHz	on	none

- b) Carry out the test a) to f) in subclause 12.5.2.2 except, in test e), use the methods described in annex C (conducted spurious emissions). The test shall be carried out over the RF ranges from 30 MHz to 12,75 GHz and the power measurements shall be performed using the resolution bandwidth as indicated in table 10.

12.5.3.3 Verdict criteria

The spurious emissions, as measured, shall not be greater than 250 nW at frequencies below 1 GHz and 1 μ W at frequencies above 1 GHz.

In addition, not regarding up to 2 instances of a continuous-wave spurious signal for PPs for which the total peak power level shall be less than 250 nW as measured in a 3 MHz measurement bandwidth, the peak power level shall be less than 20 nW in a 100 kHz measuring bandwidth for the following broadcast bands:

47 - 74 MHz;
87,5 - 108 MHz;
108 - 118 MHz;
174 - 230 MHz;
470 - 862 MHz.

13 Radio receiver testing

13.1 Radio receiver sensitivity

The requirements are given in ETS 300 175-2 [2], subclause 6.2.

13.1.1 Definition

The radio receiver sensitivity is defined as the power level at the receiver input at which the Bit Error Ratio (BER) is 0,001. The radio receiver sensitivity shall be 60 dB μ V/m (-83 dBm) or better.

13.1.2 Test environment

The test should preferably take place at a test site, otherwise a test fixture or temporary connector shall be used.

If the EUT has an antenna connector then it shall be used to connect the EUT to the LT.

The test shall take place under nominal supply voltage conditions and at a nominal temperature.

13.1.3 Method of measurement

- a) The EUT shall be oriented in the reference position as determined in subclause 5.11.3 if no antenna connector is available.
- b) The LT shall be programmed to set its RF transmission to a power level such that 60 dB μ V/m (-83 dBm) shall be present at the input of the EUT receiver.
- c) The LT shall place the EUT in a mode whereby the EUT is positioned in a LT specified slot and RF channel $c = 5$. If so equipped, the handover function in the EUT shall be disabled (see subclause 5.9.3 for the appropriate test message reference).
- d) The EUT shall be placed in a test mode whereby it performs the loopback function as referenced in subclause 5.9.3.
- e) A test modulation signal D-M2 (see subclause 5.8.4.4) is generated by the LT.
- f) The LT shall calculate the BER of the EUT as determined in subclause 5.11.4 and annexes E and F.
- g) The LT shall offset the frequency of the test signal by 50 kHz and repeat parts b) to f). This sequence of steps shall be repeated twice to include both positive and negative frequency offsets.
- h) Steps b) to f) shall be repeated for RF channels $c = 0$ and 9.

13.1.4 Verdict criteria

The BER of the EUT, as measured, shall be less than or equal to 0,001 for the duration of this test.

13.2 Radio receiver reference BER

The requirements are given in subclause 6.3 of ETS 300 175-2 [2].

13.2.1 Definition

The radio receiver reference BER is the maximum allowed BER for a power level at the receiver input of -73 dBm or greater (i.e. 70 dB μ V/m).

13.2.2 Test environment

The test shall take place at a test site or using a test fixture for equipment with integral antenna.

If the EUT has an antenna connector then it shall be used to connect the EUT to the LT.

The test shall take place under nominal supply voltage conditions and at a nominal temperature.

13.2.3 Method of measurement

- a) The EUT shall be oriented in the reference position as determined in subclause 5.11.3 if no antenna connector is available.
- b) The LT shall be programmed to set its RF transmission to a power level of 70 dB μ V/m (-73 dBm) at the input of the EUT receiver.
- c) The LT shall place the EUT in a mode whereby the EUT is positioned in a LT specified slot and RF channel $c = 5$ with handover disabled (see subclause 5.9.3 for the appropriate test message reference).
- d) The EUT shall be placed in a test mode whereby it performs the loopback function as referenced in subclause 5.9.3;
- e) A test modulation signal D-M2 (see subclause 5.8.4.4) is generated by the LT.
- f) The LT shall calculate the BER of the EUT as determined in subclause 5.11.4 and annexes E and F.
- g) Steps b) to f) shall be repeated for RF channels $c = 0$ and 9.

13.2.4 Verdict criteria

The BER of the EUT, as measured, shall be 0,00001 or less.

13.3 Radio receiver interference performance

The requirements are given in ETS 300 175-2 [2], subclause 6.4.

13.3.1 Definition

The ability of DECT equipment to continue receiving in the presence of an interfering signal on the same or different DECT RF channel.

13.3.2 Test environment

The test shall take place at a test site or using a test fixture for equipment with integral antenna.

If the EUT has an antenna connector then it shall be used to connect the EUT to the LT.

The test shall take place under nominal supply voltage conditions and at a nominal temperature.

13.3.3 Method of measurement

- a) The EUT shall be oriented in the reference position as determined in subclause 5.11.3 if no antenna connector is available.
- b) The LT shall be programmed to set its RF transmission to a power level of 70 dB μ V/m (-73 dBm) at the input of the EUT receiver.
- c) The LT shall place the EUT in a mode whereby the EUT is positioned in a LT specified slot and RF channel $c = 5$. If so equipped, the handover function in the EUT shall be disabled (see subclause 5.9.3 for the appropriate test message reference).
- d) The EUT shall be placed in a test mode whereby it performs the loopback function as referenced in subclause 5.9.3.
- e) A test modulation signal D-M2 (see subclause 5.8.4.4) is generated by the LT.
- f) The LT shall transmit in addition to the D-M2 data test pattern, a modulated DECT-like carrier (see subclause 5.8.4.1) on channel "Y" whose level is determined by table 11.

Table 11

Interferer on RF Channel "Y"	Interferer signal strength	
	(dB μ V/m)	(dBm)
Y = M	60	-83
Y = M \pm 1	83	-60
Y = M \pm 2	104	-39
Y = any other DECT channel	110	-33

The RF carriers "Y" shall include the three nominal DECT RF carrier positions immediately outside each edge of the DECT band.

- g) The LT shall calculate the BER of the EUT as determined in subclause 5.11.4 and annexes E and F.
- h) Steps b) to g) shall be repeated so that the single interfering DECT-like carrier has been placed on all the remaining DECT channels. Table 11 indicates the amplitude of the interferer;
- i) Steps b) to h) shall be repeated for RF channels $c = 0$ and 9.

13.3.4 Verdict criteria

The BER of the EUT, as measured, shall be 0,001 or less.

13.4 Radio receiver blocking case 1: owing to signals occurring at the same time but on other frequencies

The requirements are given in ETS 300 175-2 [2], subclause 6.5.1.

13.4.1 Definition

The receiver should work in the presence of strong signals on other frequencies. These interferers may be modulated carriers or single continuous-wave carriers.

13.4.2 Test environment

The test shall take place at a test site or using a test fixture for equipment with integral antenna.

If the EUT has an antenna connector then it shall be used to connect the EUT to the LT.

The test shall take place under nominal supply voltage conditions and at a nominal temperature.

13.4.3 Method of measurement

- a) The EUT shall be oriented in the reference position as determined in subclause 5.11.3 if no antenna connector is available.
- b) The power level of the RF transmission from the LT shall be set to -80 dBm.
- c) The LT shall place the EUT in a mode whereby the EUT is positioned in a LT specified slot and frequency (F_C). The frequency chosen shall be RF channel $c = 5$ of the DECT RF channels. If so equipped, the handover function in the EUT shall be disabled (see subclause 5.9.3 for the appropriate test message reference).
- d) The EUT shall be placed in a test mode whereby it performs the loopback function as referenced in subclause 5.9.3.
- e) A test modulation signal D-M2 (see subclause 5.8.4.4) is generated by the LT.
- f) The LT shall transmit in addition to the D-M2 signal a single continuous-wave interferer with an equivalent frequency change rate not exceeding the following:

Equipment type	Frequency change rate
A-field only	1 MHz/s
half-slot	2,5 MHz/s
full-slot	10 MHz/s
double-slot	20 MHz/s

The frequency (f) and levels are determined by table 12. If discrete frequency steps are used, the step shall not exceed 1 MHz.

Table 12

Frequency (f)	Continuous wave interferer level	
	For radiated measurements dB μ V/m	For conducted measurements dBm
$25 \text{ MHz} \leq f < 1 \text{ 780 MHz}$	120	-23
$1 \text{ 780 MHz} \leq f < 1 \text{ 875 MHz}$	110	-33
$ f - F_C > 6 \text{ MHz}$	100	-43
$1 \text{ 905 MHz} < f \leq 2 \text{ 000 MHz}$	110	-33
$2 \text{ 000 MHz} < f \leq 12,75 \text{ GHz}$	120	-23

- g) The LT shall for frequencies and conditions defined under part f) monitor bit errors with time intervals not exceeding 1 s.

- h) at frequencies where 1 or more errors are found, the LT shall calculate the BER of the EUT as determined in subclause 5.11.4 and annexes E and F. If the measured BER exceeds 0,001 the frequency shall be recorded.
- i) For all frequencies recorded under h) the measurement and recording procedure shall be repeated, but with the interferer level decreased to 100 dB μ V/m for radiated measurements or -43 dBm for conducted measurements.
- j) For all frequencies recorded under i), the measurement and recording procedure shall be repeated, but with the interferer level decreased to 80 dB μ V/m for radiated measurements or -63 dBm for conducted measurements.

13.4.4 Verdict criteria

A spurious response frequency is defined as the nominal DECT carrier frequency F_g closest to a frequency recorded under part g).

NOTE: F_g is defined in ETS 300 175-2 [2], subclause 4.1.1 as the nominal DECT RF carrier whose centre frequency is generated by the formula:

$$F_g = F_0 - g \times 1\,728 \text{ kHz};$$

where $F_0 = 1\,897,344 \text{ MHz}$ and g is any integer.

An occurrence is defined as a group of up to 3 spurious response frequencies with consecutive values of g . Two occurrences are defined as separate if between these occurrences there is at least one nominal DECT carrier frequency that is not a spurious response frequency.

Every recorded frequency is defined to be related to the closest spurious response frequency.

Every recorded frequency is defined to be related to the occurrence which contains the related spurious response frequency.

All frequencies recorded under g) shall only relate to a maximum of 8 separated occurrences.

All frequencies recorded under h) shall only relate to a maximum of 4 separated occurrences.

No frequency shall have been recorded under i).

13.5 Radio receiver blocking case 2: owing to signals occurring at a different time

The requirements are given in ETS 300 175-2 [2], subclause 6.5.2.

13.5.1 Definition

When a high level interferer is present in a physical channel other than the one the receiver is on, the receiver is able to continue receiving the desired signal.

13.5.2 Test environment

The test shall take place at a test site or using a test fixture for equipment with integral antenna.

If the EUT has an antenna connector then it shall be used to connect the EUT to the LT.

The test shall take place under nominal supply voltage conditions and at a nominal temperature.

13.5.3 Method of measurement

- a) The EUT shall be orientated in the reference position as determined in subclause 5.11.3 if no antenna connector is available.
- b) The LT shall be programmed to set its RF transmission to a power level of 70 dB μ V/m (-73 dBm) at the input of the EUT receiver.
- c) The LT shall place the EUT in a mode whereby the EUT is positioned in RF channel $c = 5$ and slot-pair N (i.e. slot N and slot $N + 12$ with $N \geq 2$). If so equipped, the handover function in the EUT shall be disabled (see subclause 5.9.3 for the appropriate test message reference).
- d) The EUT shall be placed in a test mode whereby it performs the loopback function as referenced in subclause 5.9.3.
- e) A test modulation signal D-M2 (see subclause 5.8.4.4) is generated by the LT.
- f) The LT shall transmit at the same time a DECT-like physical packet interferer at a level of -14 dBm (129 dB μ V/m) in slot $N - 2$ for measuring a PT and slot $(N + 12) - 2$ for measuring an FT (see subclause 5.8.4.1 for a description of this interferer).

The power level of any emissions by the LT shall be less than -93 (50 dB μ V/m) dBm on slot $N-1$ for measuring a PT and on slot $(N + 12) - 1$ for measuring an FT.

- g) The LT shall be programmed to set its RF transmission to a power level of 60 dB μ V/m (-83 dBm) at the input of the EUT receiver in slot N for measuring a PT and in slot $N + 12$ for measuring an FT.
- h) The LT shall calculate the BER of the EUT as determined in subclause 5.11.4 and annexes E and F.
- i) Steps b) to h) shall be repeated with the EUTs receiver placed on RF channels $c = 0$ and 9.

13.5.4 Verdict criteria

The BER of the EUT as measured shall be 0,001 or less for the duration of this test.

13.6 Receiver intermodulation performance

The requirements are given in ETS 300 175-2 [2], subclause 6.6.

13.6.1 Definition

With a call set up on a particular physical channel, two interferers are introduced so that they can produce an intermodulation product on the physical channel already in use.

13.6.2 Test environment

The test should preferably take place at a test site, otherwise a test fixture shall be used.

If the EUT has an antenna connector then it shall be used to connect the EUT to the LT.

The test shall take place under nominal supply voltage conditions and at a nominal temperature.

13.6.3 Method of measurement

- a) The EUT shall be oriented in the reference position as determined in subclause 5.11.3 if no antenna connector is available.
- b) The LT shall be programmed to set its RF transmission level to a power level of 63 dB μ V/m (-80 dBm) at the input of the EUT receiver.
- c) The EUT's RF channel is recorded as channel "M".
- d) The LT shall place the EUT in a mode whereby the EUT is positioned in a LT specified slot and frequency. If so equipped, the handover function in the EUT shall be disabled (see subclause 5.9.3 for the appropriate test message reference).
- e) The EUT shall be placed in a test mode whereby it performs the loopback function as referenced in subclause 5.9.3.
- f) A test modulation signal D-M2 (see subclause 5.8.4.4) is generated by the LT.
- g) The LT shall then transmit in addition to the D-M2 test signal, a modulated DECT-like carrier "B" and a continuous-wave carrier "A" whose intermodulation product is present within the DECT channel "M" of the EUT. The level of these carriers shall be set to -47 dBm (96 dB μ V/m) at the receiver input of the EUT. The LT shall calculate the BER of the EUT as determined in subclause 5.11.4 and annexes E and F. The measurement shall be performed 4 times with the interfering carriers and the EUT receive channel positioned on the DECT RF channels as given in table 13.

Table 13

M	A	B
5	7	9
5	3	1
0	2	4
9	7	5

13.6.4 Verdict criteria

The BER of the EUT, as measured, shall be less than 0,001 for the duration of this test.

13.7 Spurious emissions when the PP has no allocated transmit channel

The requirements are given in ETS 300 175-2 [2], subclause 6.7.

13.7.1 Definition

The power level of any spurious emission when the PP has not been allocated a transmit channel.

13.7.2 Test environment

The test shall take place at a test site.

Connection between the EUT and the LT shall be made by means of a test antenna.

The test shall take place under nominal supply voltage conditions and at a nominal temperature.

13.7.3 Method of measurement

a) The analyser controls shall be set to the following:

frequency span:	as required for frequency range;
resolution bandwidth:	1 MHz (in DECT band) 100 kHz (outside DECT band);
video bandwidth:	greater than resolution bandwidth;
averaging:	none;
peak hold:	on;
filtering type:	synchronously tuned for measurements in the DECT band.

b) The EUT shall be oriented in the reference position as determined in subclause 5.11.3.

c) The EUT shall be placed into a receive or idle mode for the duration of this test.

d) The test shall be carried out across the RF range of 30 MHz to 4 GHz and the power measurements shall be performed using the resolution bandwidths as indicated in a).

13.7.4 Verdict criteria (outside the DECT band)

The EUT shall conform to the following limits:

- the emissions as measured shall not be greater than 2 nW between 30 MHz and 1 GHz; and
- between 1 GHz and 4 GHz, the emissions as measured shall not exceed 20 nW.

13.7.5 Verdict criteria (inside the DECT band)

The EUT shall conform to the following limits:

- the power level as measured of any spurious emissions shall not exceed 2 nW in a 1 MHz bandwidth.

The following exceptions are allowed:

- a) in one 1 MHz, the maximum allowable Effective Radiated Power (ERP) shall be 20 nW;
- b) in up to two bands of 30 kHz, the maximum ERP shall be less than 250 nW.

14 Synchronization port (FP only)

The requirements are given in ETS 300 175-2 [2], annex C.

14.1 Description

The (optional) synchronization ports allow adjacent DECT FPs to achieve frame synchronization.

Two classes of synchronization are specified:

Class 1: guard band alignment, no handover between FPs;

Class 2: guard band alignment, handover between FPs.

The requirements of handover result in different timing tolerances between the two classes.

The synchronization pulse is positive (true) logic. The voltage levels of the pulse corresponds to those defined in CCITT Recommendation V.11 [10].

14.2 Test environment

The test shall take place at a test site or using a test fixture for equipment with integral antenna.

If the EUT has an antenna connector then it shall be used to connect the EUT to the LT.

The test shall take place under nominal supply voltage conditions and at a nominal temperature.

14.3 FP as a master

14.3.1 Method of measurement

The applicant shall declare to the testing laboratory the time required for system synchronization by the EUT:

- a) the EUTs' synchronization port shall be connected to the LT's input port;
- b) a bearer shall be set-up between the EUT and the LT;
- c) the LT shall:
 - 1) use the sampling method described in subclause 5.11.2.2 to capture a representation a physical packet transmitted by the EUT;
 - 2) determine the position of bit p0 in the physical packet. If the bearer is not in slots 0 and 12 of the DECT frame the position of bit p0 in slot 0 shall be calculated;
 - 3) at the same time, sample the synchronization pulse coming out of the EUT. The frame number in which the pulse is sampled shall be recorded;
- d) step c) shall be repeated for 50 frames;
- e) the LT shall calculate the widths of the synchronization pulses. The calculated widths shall be recorded along with the frame numbers;
- f) the LT shall calculate the time delay, T_d , between the falling edge of each synchronization pulse to bit p0 of slot 0 (calculated or measured) to that pulse's sampled RF packet;
- g) the synchronization port of the EUT shall be tested as specified in CCITT Recommendation V.11 [10] subclauses 5.2.1, 5.2.2, and 5.3.

14.3.2 Verdict criteria

The time delay T_d , pulse widths, and output port characteristics shall meet the following limits:

- a) the width of the synchronization pulse as measured shall be between 2 and 5 ms for frame 0 and between 5 μ s and 1 ms for all other frames
- b) T_d as measured shall be 15 μ s \pm 5 μ s for class 1 FPs;
- c) T_d as measured shall be 15 μ s \pm 2 μ s for class 2 FPs;
- d) The synchronization port characteristics as measured in g) shall not exceed the limits stated in CCITT Recommendation V.11 [10] clause 5.2.1, 5.2.2, and 5.3.

14.4 FP as a slave

14.4.1 Method of measurement

- a) The EUT's synchronization input port shall be connected to the LT's output port.
- b) A bearer shall be set up between the LT and the EUT.
- c) The LT shall:
 - 1) generate a synchronization pulse in conformance with the limits specified for master FPs in ETS 300 175-2 [2], annex C.
 - 2) use the sampling method described in subclause 5.11.2.2 to capture a representation a physical packet transmitted by the EUT;
 - 3) determine the position of bit p0 in the physical packet. If the bearer is not in slots 0 and 12 of the DECT frame the position of bit p0 in slot 0 shall be calculated.
- d) c) shall be repeated for 50 frames.
- f) The LT shall calculate the time delay, T_d , between the falling edge of each synchronization pulse it generated to bit p0 of slot 0 (calculated or measured) to that pulse's sampled RF packet.
- g) If the EUT is declared as being a class 2 FP, then the test laboratory shall verify that the time delay T_d can be set to 0 μ s, 15 μ s, and 20 μ s. The method of adjustment is applicant specific and shall be declared to the test laboratory.
- h) The input synchronization port of the EUT shall be tested as specified in CCITT Recommendation V.11 [10] subclauses 6.2, 6.3 and 6.4.

14.4.2 Verdict criteria

The time T_d delay as measured shall be within 15 μ s \pm 5 μ s.

The input port characteristics as measured shall not exceed the limits specified in CCITT Recommendation V.11 [10] subclauses 6.2, 6.3 and 6.4.

14.5 FP with integrated Global Positioning System (GPS) synchronization

14.5.1 Method of measurement

This test is applicable if the FP is declared by the applicant to have integrated GPS synchronization:

- a) a bearer shall be set up between the EUT and the LT;
- b) the LT shall:
 - 1) use the sampling method described in subclause 5.11.2.2 to capture a representation a physical packet transmitted by the EUT;
 - 2) determine the position of bit p0 in the physical packet. If the bearer is not in slots 0 and 12 of the DECT frame the position of bit p0 in slot 0 shall be calculated. The frame number of the sampled packet shall be recorded.
 - 3) by means of it's integrated GPS receiver generate a reference synchronization pulse. The falling edge of the frame 0 synchronization pulse shall coincide with $T_{GPS} \bmod 4 = 0$. (T_{GPS} is the GPS time);

- c) step b) shall be repeated 50 times;
- d) the LT shall calculate the time delay, T_d , between the falling edge of each reference synchronization pulse generated by the LT to bit p0 of slot 0 (calculated or measured) to that pulse's sampled RF packet.

14.5.2 Verdict criteria

The frame numbers and the time delay T_d shall meet the following limits:

The frame numbers shall conform to the GPS timing as described in 14.5.1 b) part 3).

- a) T_d as measured shall be $15 \mu\text{s} \pm 5 \mu\text{s}$ for class 1 FPs;
- b) T_d as measured shall be $15 \mu\text{s} \pm 2 \mu\text{s}$ for class 2 FPs;
- c) If the EUT at the same time is a master it shall also fulfil the requirements of subclause 14.3.

14.6 External GPS synchronization device

14.6.1 Method of measurement

- a) The EUT's synchronization port shall be connected to the LT's input port.
- b) The LT shall by means of its integrated GPS receiver generate a reference synchronization pulse related to the GPS timing as described in 14.5.1 b) part 3).
- c) The LT shall measure the time difference T_e between the falling edge of the pulse generated by the EUT and the falling edge of the reference pulse generated by the LT.
- d) The lower tester shall measure the width of the synchronization pulse generated by the EUT and at the same time record whether the reference synchronization pulse was a frame 0 pulse or not.
- e) Steps c) to d) shall be repeated 50 times.
- f) The synchronization rate of the EUT shall be tested as specified in CCITT Recommendation V.11 [10] subclauses 5.2.1, 5.2.2, and 5.3.

14.6.2 Verdict criteria

The timing accuracy T_e , pulse widths, and output port characteristics shall meet the following limits:

- a) the timing accuracy T_e , as measured, shall be within $\pm 5 \mu\text{s}$ for class 1 FPs;
- b) the timing accuracy T_e , as measured, shall be within $\pm 2 \mu\text{s}$ for class 2 FPs;
- c) the width of the synchronization pulse as measured shall be between 2 and 5 ms for frame 0 and between $5 \mu\text{s}$ and 1 ms for all other frames;
- d) the synchronization port characteristics as measured in f) shall not exceed the limits stated in CCITT Recommendation V.11 [10] clause 5.2.1, 5.2.2, and 5.3.

15 EMC

Technical requirements for EMC performance and testing of the equipment are covered by the relevant standards applicable to the EMC Directive, 89/336/EEC [15].

16 Equipment identity testing

16.1 PP

This clause describes the protection requirements of the mandatory IPEI (International Portable Equipment Identity) equipment code. For information on the procurement and coding of the IPEI, refer to ETS 300 175-6 [6].

The applicant shall declare that it is not possible for the user to alter the IPEI using any normally accessible procedure.

The applicant shall supply, in addition to the equipment, sufficient means in the equipment with instructions in the documentation to permit validation of the equipment manufacturer's code and verification of the existence of the Portable equipment Serial Number (PSN) code in the equipment.

16.2 FP

The applicant shall declare that:

- DECT FPs which do not transmit the TA escape message transmits the N_T message as defined in ETS 300 175-3 [3] at least once every 10 seconds on all active physical channels;
- these N_T identity messages are transmitted with the appropriate A-field header code as defined in ETS 300 175-3 [3] and the N_T message contains an ETSI distributed code as defined in ETS 300 175-6 [6].

17 Efficient use of the radio spectrum

17.1 Channel selection

The applicant shall declare that he conforms to all obligatory conditions in ETS 300 175-3 [3], subclauses 11.4 and 11.6.

17.2 Channel confirmation

17.2.1 For the PT

The applicant shall declare that for the PT:

- the first PT transmission on the newly selected channel shall be made in accordance with the scan sequence of the addressed RFP;
- to continue transmitting on the newly selected physical channel the PT shall receive an indication that the FT is receiving the PT transmissions within 2 frames of the first PT transmission.

17.2.2 For the FT

The applicant shall declare that for the FT:

- the RFP shall not transmit on more than 2 physical channels for which complementary physical channels do not exist;
- a complementary physical channel is a physical channel between the same two radio endpoints which occurs 5 ms before or after the physical channel to which it is complementary;
- when an FT is addressing a specific PT then the first FT transmission shall be made in accordance with the scan sequence of the addressed PT receiver;
- to continue transmitting on the selected physical channel the FT shall receive an indication that the PT is receiving the FT transmissions within 2 frames of the first FT transmission.

17.3 Channel release

The applicant shall declare that:

- a radio end point shall cease transmission on all physical channels if it has not received a valid indication of the other radio endpoint's identity within 10 seconds of the receipt of the last indication;
- a radio end point which transmits on both the physical channel and complementary physical channel shall cease to transmit on the channels if either:
 - a) the receiving endpoint indicates to the transmitting endpoint that transmission shall cease on both these physical channels; or
 - b) the transmitting FT or PT is no longer attempting to receive at least one physical channel from the FT or PT to which it is transmitting.

17.4 General

For an FT or PT the applicant shall declare that:

- multibearer connections shall only exist in full slot and double slot transmission mode;
- the EUT is capable of communicating on all 10 DECT RF channels.

Annex A (informative): Bibliography

- TBR 6: "Radio Equipment and Systems (RES); Digital Enhanced Cordless Telecommunications (DECT); General terminal attachment requirements".
- TBR 10: "Radio Equipment and Systems (RES); Digital European Cordless Telecommunications (DECT); General terminal attachment requirements: Telephony applications".
- ETS 300 001: "Attachments to Public Switched Telephone Network (PSTN); General technical requirements for equipment connected to an analogue subscriber interface in the PSTN".
- ETR 015: "Radio Equipment and Systems (RES); Digital European Cordless Telecommunications (DECT); Reference document".
- ETR 043: "Radio Equipment and Systems (RES); Digital European Cordless Telecommunications (DECT); Common interface Services and Facilities requirements specification".
- ETR 056: "Radio Equipment and Systems (RES); Digital European Cordless Telecommunications (DECT); System description document".
- IEC Publication 489-3 (1988), Appendix F, pages 130 to 133.
- Technical Report FTZ N° 512 TB 9: "Construction of a Stripline".
- Technical Report ZVEI AK-R 90/20: "Construction of an Anechoic Chamber".

Annex B (normative): Procedures for test fixture calibration and for measurement of radiated spurious emissions

B.1 Calibration of test fixture for receiver measurements

The calibration procedure utilizes the average measured usable sensitivity of the receiver. The average measured usable sensitivity expressed as field strength for bit stream shall be the average of eight measurements of field strength, expressed in dB μ V/m, at the nominal frequency of the receiver and with specified test modulation which produces after demodulation a data signal with a bit error ratio of 10^{-3} , when the receiver is rotated in 45° increments, starting at the reference orientation.

B.1.1 Method of measurement

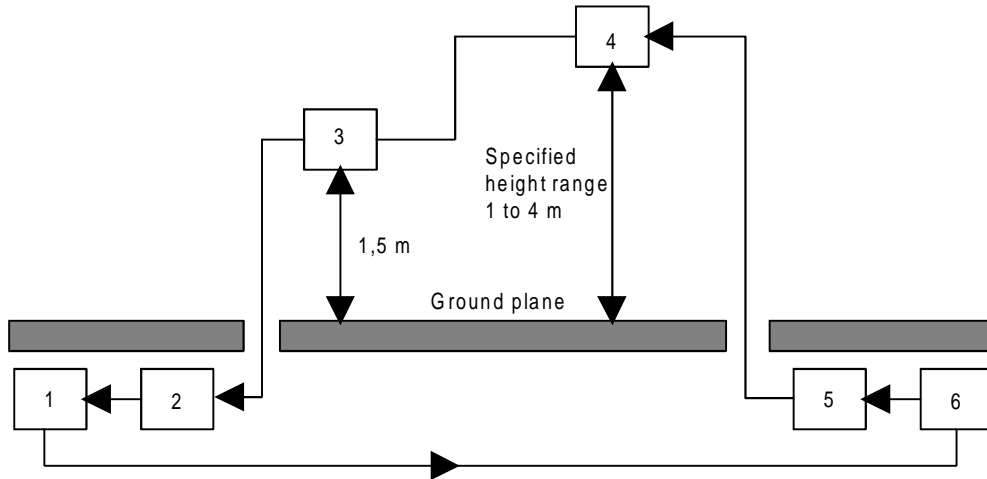

- 1) Bit error measuring test set;
- 2) Termination;
- 3) Receiver under test;
- 4) Test antenna;
- 5) DECT Signal generator;
- 6) Bit stream generator.

Figure B.1: Measurement arrangement N°1

- a) A test site which fulfils the requirements of the specified frequency range of this measurement shall be used. The test antenna shall be oriented initially for vertical polarization unless otherwise stated.

A signal generator capable of producing a DECT signal shall be connected to the test antenna. The signal generator shall be at the nominal frequency of the receiver and shall be modulated by the test modulation D-M2. The receiver under test shall be placed on the support in its standard position and oriented so that a face, specified by the applicant, is normal to the direction of the test antenna. This is the reference orientation for the measurement.

- b) The bit pattern of the modulating signal shall be compared to the bit pattern obtained from the receiver after demodulation.
- c) The output level of the signal generator shall be adjusted until a bit error ratio of 10^{-3} is obtained.
- d) The test antenna shall be raised or lowered again through the specified height range to find the lowest level of the test signal which produces the same bit error ratio.
- e) Record the minimum signal generator level from c) or d).

- f) Steps b) to e) shall be repeated for the eight positions 45° apart of the receiver and the corresponding values of the generator output which produces the same bit error ratio will be determined and recorded.
- g) Using the calibration of the test site, calculate the eight field strengths $X_i(\mu\text{V/m})$ corresponding to the output level above of the signal generator. The average measured usable sensitivity expressed as field strength X_{mean} (dB $\mu\text{V/m}$) is given by:

$$X_{\text{mean}} = 20 \log \left[\frac{8}{\sum_{i=1}^8 \left(\frac{1}{X_i^2} \right)} \right]^{1/2} \tag{3}$$

- h) Measurements b) to g) shall be repeated with the test antenna oriented in horizontal polarization.
- i) Record the lower value of the two recorded in steps g) and h) above.
- j) Using the test fixture in measuring arrangement N°2 the measurement may also be performed under extreme test conditions.

Additional uncertainties can occur under extreme test conditions due to the calibration of the test fixture.

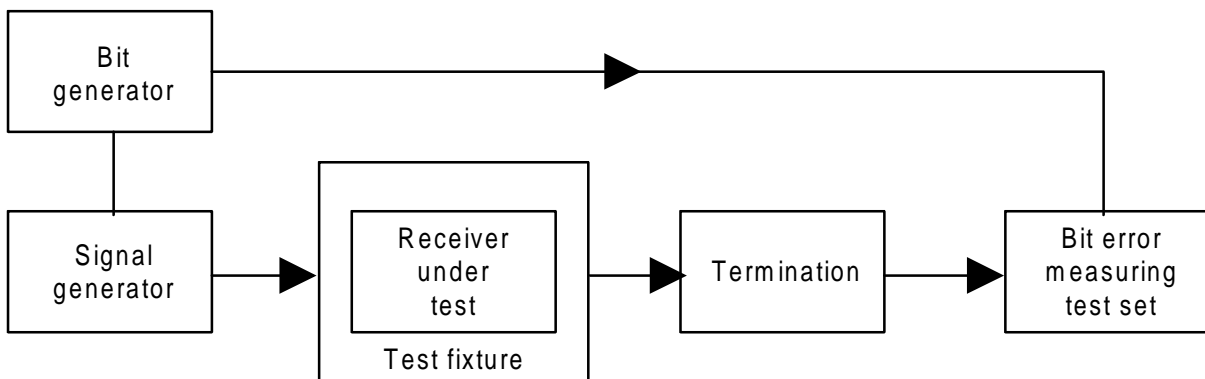

Figure B.2: Measurement arrangement N°2

- k) The test signal input level providing a BER of 10^{-3} shall be determined under normal and extreme test conditions and the difference in dB is noted. This difference shall be algebraically added to the average measured usable sensitivity to radiated fields for bit stream expressed in dB $\mu\text{V/m}$ under normal test conditions, to obtain the same quantity under extreme test conditions.

B.2 Radiated measurements

B.2.1 General

This clause contains all methods of measurements involving the absolute measurement of a radiated field. This field may be radiated by an integral antenna and/or by the cabinet of the equipment itself.

The standard test site shall be a calibrated open air test site, whose dimensions are appropriate to the frequency range of measurements.

In some cases operating on a test site may produce electromagnetic perturbation or, conversely, external radiation may disturb the measurement. For these reasons, and also in order to reduce the space required, other arrangements may be used, such as:

- stripline arrangements;
- anechoic chamber;
- indoor test site.

The methods of measurement described in this annex are based on an open air test site, unless otherwise stated. If a stripline arrangement, an anechoic chamber or an indoor test site are used, the changes which apply to the method of measurement are indicated in their corresponding descriptions. For each radiated measurement, the nature and the dimensions of the test arrangement used shall be recorded in the test report.

For extreme test conditions a test fixture shall also be required.

For equipment normally operated from internal batteries it may be necessary to operate it from an external power source. A RF filter may be required to avoid radiation to or from the power leads.

B.2.2 Radiated spurious emissions

B.2.2.1 Definition

Spurious emissions are emissions at frequencies, other than those of the carrier and sidebands associated with normal modulation, radiated by the antenna and by the cabinet of the transmitter.

They are specified as the radiated power of any discrete signal.

B.2.2.2 Method of measurement

This method of measurement applies to transmitters having an integral antenna.

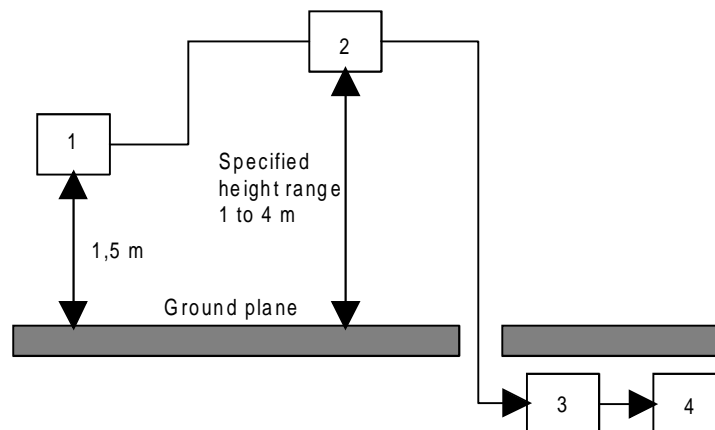

- 1) Transmitter under test;
- 2) Test antenna;
- 3) High "Q" (notch) or high pass filter;
- 4) Spectrum analyser or selective voltmeter.

Figure B.3: Measurement arrangement N°1

- a) A test site which fulfils the requirements of the specified frequency range of this measurement shall be used. The test antenna shall be oriented initially for vertical polarization and connected to a spectrum analyser or a selective voltmeter, through a suitable filter to avoid overloading of the spectrum analyser or selective voltmeter. The bandwidth of the spectrum analyser is set to a suitable value to correctly perform the measurement.

For the measurement of spurious emissions below the second harmonic of the carrier frequency the filter used shall be a high "Q" (notch) filter centred on the transmitter carrier frequency and attenuating this signal by at least 30 dB.

For the measurement of spurious emissions at and above the second harmonic of the carrier frequency the filter used shall be a high pass filter with a stop band rejection exceeding 40 dB. The cut-off frequency of the high pass filter shall be approximately 1,5 times the transmitter carrier frequency.

The transmitter under test shall be placed on the support in its standard position and shall be switched on.

- b) The radiation of any spurious emission shall be detected by the test antenna and spectrum analyser or selective voltmeter over the specified frequency range, except for the channel on which the transmitter is intended to operate and its adjacent channels. The frequency of each spurious emission detected shall be recorded. If the test site is disturbed by interference coming from outside, this qualitative search may be performed in a screened room, with a reduced distance between the transmitter and the test antenna.
- c) For each frequency at which a emission has been detected, the spectrum analyser or selective voltmeter shall be tuned and the test antenna shall be raised or lowered through the specified height range until a maximum signal level is detected on the spectrum analyser or selective voltmeter.
- d) The transmitter shall be rotated through 360° about a vertical axis, until the maximum signal is received.
- e) The test antenna shall be raised or lowered again through the specified height range until the maximum is obtained. This level shall be recorded.

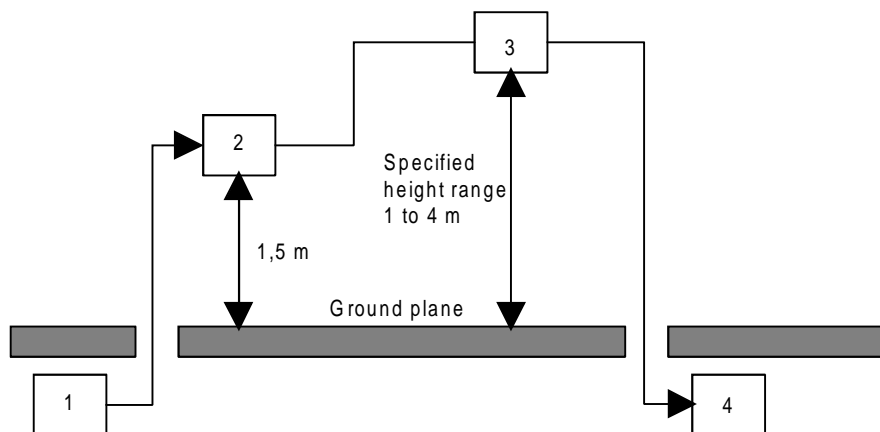

- 1) Signal generator;
- 2) Substitution antenna;
- 3) Test antenna;
- 4) Spectrum analyser or selective voltmeter.

Figure B.4: Measurement arrangement N°2

- f) Using measurement arrangement N°2 the substitution antenna shall replace the transmitter antenna in the same position and in vertical polarization. It shall be connected to the signal generator.
- g) For each frequency at which an emission has been detected, the signal generator, substitution antenna, and spectrum analyser or selective voltmeter shall be tuned. The test antenna shall be raised or lowered through the specified height range until the maximum signal level is detected on the spectrum analyser or selective voltmeter. The level of the signal generator shall be adjusted giving the same signal level on the spectrum analyser or selective voltmeter as in e) and this level shall be recorded.

This value, after corrections due to the gain of the substitution antenna, referred to a resonant half wavelength dipole below 1 GHz or to an isotropic radiator above 1 GHz and the cable loss between the signal generator and the substitution antenna, is the radiated spurious emission level of this frequency.

- h) Steps c) to g) shall be repeated with the test antenna oriented in horizontal polarization.
- i) Steps c) to h) shall be repeated with the transmitter in stand-by condition if this option is available.

B.2.3 Cabinet radiation

B.2.3.1 Definition

Cabinet radiation is radiation at frequencies, excluding the band containing the carrier and sidebands associated with normal modulation, coming from the cabinet of the transmitter.

It is specified as the radiated power of any discrete signal.

B.2.3.2 Method of measurement

This method of measurement applies to transmitters having an antenna socket.

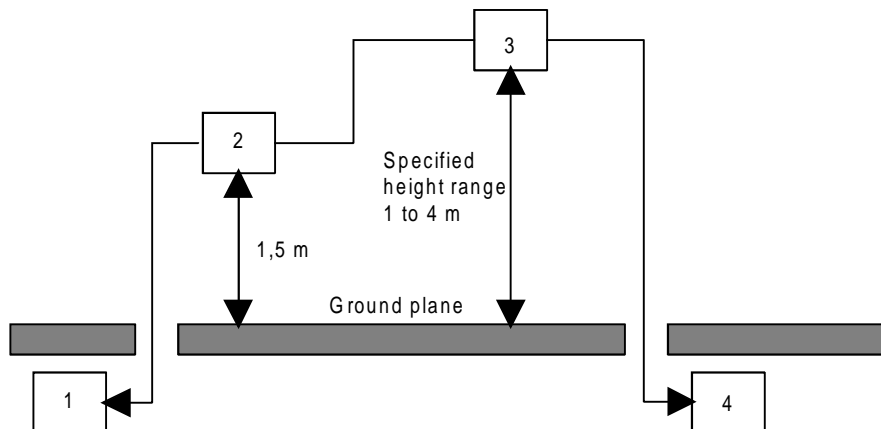

- 1) Test load;
- 2) Transmitter under test;
- 3) Test antenna;
- 4) Spectrum analyser or selective voltmeter.

Figure B.5: Measurement arrangement N°1

- a) A test site which fulfils the requirements of the specified frequency range of this measurement shall be used. The test antenna shall be oriented initially for vertical polarization and connected to a spectrum analyser or selective voltmeter. The bandwidth of the spectrum analyser or selective voltmeter shall be between 10 kHz and 100 kHz, set to a suitable value to correctly perform the measurement.

The transmitter under test shall be placed on the support in its standard position, connected to a test load and switched on.

- b) The same method of measurement as in b) to i) of subclause B.2.2 will be used.

Annex C (normative): Procedure for measurement of conducted spurious emissions

C.1 Conducted spurious emissions

C.1.1 Definition

Conducted spurious emissions are discrete signals whose power is conveyed by conduction to the test load at frequencies other than those of the carrier and sidebands resulting from the normal process of modulation.

They are specified as the power level of any discrete signal delivered into a test load.

C.1.2 Method of measurement

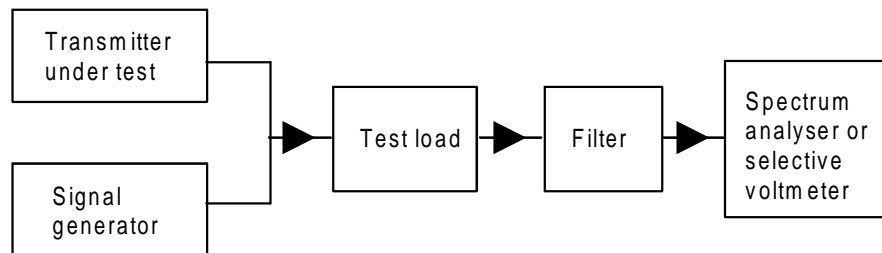

Figure C.1

- a) The transmitter shall be connected to a spectrum analyser or a selective voltmeter through a test load and an appropriate filter to avoid overloading of the spectrum analyser or selective voltmeter. The bandwidth of the spectrum analyser or selective voltmeter shall be between 10 kHz and 100 kHz. The equipment used shall have sufficient dynamic range and sensitivity to achieve the required measurement accuracy at the specified limit.

For the measurement of spurious emissions below the second harmonic of the carrier frequency the filter used shall be a high 'Q' (notch) filter centred on the transmitter carrier frequency and attenuating this signal by at least 30 dB.

For the measurement of spurious emissions at and above the second harmonic of the carrier frequency the filter used shall be a high pass filter with a stop band rejection exceeding 40 dB. The cut-off frequency of the high pass filter shall be approximately 1,5 times the transmitter carrier frequency.

Precautions may be required to ensure that the test load does not generate or that the high pass filter does not attenuate, the harmonics of the carrier.

- b) The transmitter shall be unmodulated and operating at the maximum limit of its specified power range.
- c) The frequency of the spectrum analyser or selective voltmeter shall be adjusted over the specified frequency range. The frequency and level of every spurious emission found shall be noted. The emissions within the channel occupied by the transmitter carrier and its adjacent channels shall not be recorded.
- d) If the spectrum analyser or selective voltmeter has not been calibrated in terms of power level at the transmitter output, the level of any detected components shall be determined by replacing the transmitter by the signal generator and adjusting it to reproduce the frequency and level of every spurious emission recorded in c).
- e) The absolute power level of each of the emissions noted shall be measured and recorded.
- f) The measurement shall be repeated with the transmitter in stand-by condition if this option is available.

Annex D (normative): Test Support Profile (TSP)

D.1 Introduction

This annex defines the provisions of the TSP for DECT equipment (EUT) capabilities in Test Standby Mode (TSM) and for the Lower Tester (LT) capabilities while performing the tests described in this ETS. When there exists a reference to "TSM" in this ETS, it shall be applied for both the test standby mode and the test mode(s) in operation as described in ETS 300 175-3 [3], subclause 12.2.

It specifies three different bearer set-up procedures, as described in ETS 300 175-3 [3], subclauses 10.5.1.1, 10.5.1.2 and 10.5.1.3 in order to transfer test messages described in clause 12 and subclause 7.2.5.4 of ETS 300 175-3 [3]. One of these 3 bearer set-up procedures shall be supported by the LT and EUT.

D.2 Standardized symbols for the status column

The standardized symbols for the status column are as follows:

- M for always mandatory (the capability is required to be implemented). M1, M2, M3 for mandatory in respective order for basic bearer set-up, A-field advanced single bearer set-up and B-field single bearer set-up procedures supported (if bearer set-up type n is not supported then Mn shall be understood to mean O);
- O for optional (Boolean) (the capability may be implemented, but can be ignored on receipt);
- X for prohibited or excluded (the capability is not allowed to be implemented);
- I for out of scope in the test standby mode (the capability is allowed to be implemented, but is irrelevant in the test standby mode);
- - (dash) for not applicable (the capability is not possible to implement);
- C for conditional (the capability depends on the selection of other optional and/or conditional items). C1, C2, C3 for conditional in respective order for basic bearer set-up, A-field advanced single bearer set-up and B-field single bearer set-up procedures supported (if bearer set-up type n is not supported then Cn shall be understood to mean O).

All other capabilities not shown in this annex shall be regarded as optional or out of scope. Tables D.1 and D.2 show the interpretation of these symbols in this annex.

Table D.1: Usage of symbols

Symbols\ Usage	Allowed to be implemented in the EUT	Possible in normal operation (ETS 300 175)	Possible in TSM (this ETS)	Out of scope of TSM
M	Yes	Yes	Yes	No
O	Yes	Yes	Yes	No
I	Yes	Yes	No	Yes
-	No	No	No	Yes
X	Yes	Yes	No	Yes

Table D.2: Symbols and their relation to transmit and receive events

Symbols\ TX, RX	Transmit	Receive
M	shall process and send	if received; shall process
O	allowed to be sent	if received; optionally processed
I	not possible to send (in TSM)	not possible to receive (in TSM)
-	not possible ever	not possible ever
X	not allowed to be sent in TSM	if received: not allowed to be processed in TSM

D.3 Capabilities of PP (EUT) under test

D.3.1 Services

Table D.3: Broadcast services

Broadcast services supported				
Item No.	Name of service	Ref.	PT Status	LT Status
1	Continuous broadcast	5.7.1.1	M	M
2	System identities	11.3.2	O	M
3	System information	11.3.2	M	M

D.3.2 Messages

Table D.4: Header-field messages

Header-field messages						
Item No.	Message	Ref.	Sending		Receipt	
			PT Status	LT Status	PT Status	LT Status
4	Identities information	7.1.2	M	M	O	O
5	Multiframe synchronization and system information	7.1.2	-	M	M	-
6	Escape	7.1.2	O	X	I	X
7	MAC layer control	7.1.2	M	M	M	M
9	First PP transmission	7.1.2	M	-	-	O
12	U-type, IN, SIN or IP packet number 0,1	7.1.4	M	M	M	M
16	E-type, not all CF or CLF; packet number 0	7.1.4	C3a	X	I	M3
17	E-type, not all CF; CF packet number 1	7.1.4	C3a	X	I	M3
18	E-type, all MAC control (unnumbered)	7.1.4	C3a	M3	M3	M3
19	No B-field	7.1.4	O	O	O	O

C3a: At least one of the set is mandatory for the EUT.
C3b: At least one of the set is mandatory for the LT.

Table D.5: Messages in the A-tail field

Messages in the A-tail field						
Item No.	Message	Ref.	Sending		Receipt	
			PT Status	LT Status	PT Status	LT Status
1	Identities information	7.2.2	O	M	O	O
2	Static system information	7.2.3.2	-	M	M	-
3	Extended RF carrier information	7.2.3.3	-	X	I	-
4	Fixed part capabilities	7.2.3.4	-	M	O	-
8	Q-channel escape	7.2.3.8	-	X	I	-
31	Basic CC access request	7.2.5.2.2	M1	-	-	M1
32	Basic CC bearer handover request	7.2.5.2.2	O	-	-	M1
33	Basic CC connection handover request	7.2.5.2.2	O	-	-	M1
35	Basic CC bearer confirm	7.2.5.2.2	-	M1	O	-
36	Basic CC bearer release	7.2.5.2.2	O	X	I	M1
37	Basic CC wait	7.2.5.2.3	-	X	I	-
38	Advanced CC access request	7.2.5.3.2	M2	X	I	M2
39	Advanced CC bearer handover request	7.2.5.3.3	O	X	I	M2
40	Advanced CC connection handover request	7.2.5.3.4	O	X	I	M2
41	Advanced CC unconfirmed access request	7.2.5.3.5	O	X	I	O
42	Advanced CC bearer confirm	7.2.5.3.6	O	M2	M2	O
43	Advanced CC wait	7.2.5.3.7	O	M2	O	M2
44	Advanced CC attributes_T, request	7.2.5.3.8	M2	X	I	M2
45	Advanced CC attributes_T, confirm	7.2.5.3.8	O	M2	O	O
46	Advanced CC bandwidth_T, request	7.2.5.3.9	O	X	I	O
47	Advanced CC bandwidth_T, confirm	7.2.5.3.9	O	O	O	O
51	Advanced CC release	7.2.5.3.13	O	X	I	M2
52	MAC test force transmit	7.2.5.4.2	-	M	M	-
53	MAC test loopback data	7.2.5.4.3	-	M	M	-
54	MAC test defeat antenna diversity	7.2.5.4.4	-	M	M	-
55	MAC test force bearer handover	7.2.5.4.5	-	I	I	-
56	MAC test escape	7.2.5.4.6	X	X	I	I
58	MAC test clear test modes	7.2.5.4.8	-	M	M	-
82	B-field setup, first PT transmission	7.2.5.8	O	-	-	M3
83	MAC control escape	7.2.5.9	O	X	I	O

Table D.6: Messages in the B-tail field

Messages in the B-tail field						
Item No.	Message	Ref.	Sending		Receipt	
			PT Status	LT Status	PT Status	LT Status
1	Advanced CC access request	7.3.3.2	M3	X	I	M3
2	Advanced CC bearer handover request	7.3.3.2	O	X	I	M3
3	Advanced CC connection handover request	7.3.3.2	O	X	I	M3
4	Advanced CC unconfirmed access request	7.3.3.2	O	X	I	O
5	Advanced CC bearer confirm	7.3.3.3	O	M3	M3	O
6	Advanced CC wait	7.3.3.4	O	X	O	O
9	B-field bandwidth-B request	7.3.3.6	O	X	O	O
14	Advanced CC release	7.3.3.10	O	X	O	M3
30	B-field escape	7.3.8	O	X	I	X

D.3.3 Message parameters

The slot type shall be set correctly in all message parameters.

The equipment supplier shall provide message parameter details for configuring the LT.

Table D.7: Parameters for A-field static system information message

Parameters for A-field static system information message						
Item No.	Name of Parameter	Ref.	PT Status	LT Status	Values	
					PT Allowed	LT Allowed
1	Normal-reverse	7.2.3.2.2	M	M	0,1	0
2	Slot number	7.2.3.2.3	M	M	0-11	0-11
3	Start position	7.2.3.2.4	M	M	0,2	0,2
4	QT escape bit	7.2.3.2.5	M	M	0,1	0,1
5	Number of transceivers	7.2.3.2.6	O	M	0-3	0
6	Extended RF carrier information available	7.2.3.2.7	O	M	0,1	0
7	RF carriers available	7.2.3.2.8	O	M	1-1023	1-1023
8	Carrier number	7.2.3.2.10	O	M	0-9	0-9
9	Primary receiver scan carrier number	7.2.3.2.12	O	M	0-9	0-9

Table D.8: Parameters for MAC FP capability message

Parameters for A-field MAC FP capability message						
Item No.	Name of parameter	Ref.	PT Status	LT Status	Values	
					PT Allowed	LT Allowed
1	Extended FP information	7.2.3.4.2	O	M	0,1	0
2	Double slot	7.2.3.4.2	O	M	0,1	0,1
3	Half slot	7.2.3.4.2	O	M	0,1	0,1
4	Full slot	7.2.3.4.2	O	M	0,1	0
5	Frequency control	7.2.3.4.2	O	M	0,1	0
6	Page repetition	7.2.3.4.2	O	M	0,1	0
7	C/O setup on dummy bearer allowed	7.2.3.4.2	O	M	0,1	0
8	C/L uplink	7.2.3.4.2	O	M	0,1	0
9	C/L downlink	7.2.3.4.2	O	M	0,1	0
10	Basic A-field setup	7.2.3.4.2	O	M	0,1	0,1
11	Advanced A-field setup	7.2.3.4.2	O	M	0,1	0,1
12	B-field setup	7.2.3.4.2	O	M	0,1	0,1
13	CF messages	7.2.3.4.2	O	M	0,1	0,1
14	IN minimum delay	7.2.3.4.2	O	M	0,1	0
15	IN normal delay	7.2.3.4.2	O	M	0,1	0,1
16	IP error detection	7.2.3.4.2	O	M	0,1	0,1
17	IP error correction	7.2.3.4.2	O	M	0,1	0,1
18	Multibearer connections	7.2.3.4.2	O	M	0,1	0,1

Table D.9: Parameters for higher layer information FP capability message
(ref. ETS 300 175-5 [5], annex F)

Parameters for A-field higher layer information FP capability message						
Item No.	Name of parameter	Ref.	PT Status	LT Status	Values	
					PT Allowed	LT Allowed
1	ADPCM/G.726 Voice service	a32	O	M	0,1	0,1
2	Public Access Profile (PAP) supported	a33	O	M	0,1	0,1
3	Non-voice circuit switched service	a34	O	M	0,1	0,1
4	Non-voice packet switched service	a35	O	M	0,1	0,1
5	Standard authentication required	a36	O	M	0,1	0,1
6	Standard ciphering supported	a37	I	M	0,1	0
7	Location registration supported	a38	O	M	0,1	0,1
8	SIM services available	a39	O	M	0,1	0,1
9	Non-static Fixed Part (FP)	a40	O	M	0,1	0,1
10	CISS services available	a41	O	M	0,1	0,1

(continued)

Table D.9 (concluded): Parameters for higher layer information FP capability message
(ref. ETS 300175-5 [5], annex F)

Parameters for A-field higher layer information FP capability message						
Item No.	Name of parameter	Ref.	PT Status	LT Status	Values	
					PT Allowed	LT Allowed
11	CLMS services available	a42	O	M	0,1	0,1
12	COMS services available	a43	O	M	0,1	0,1
13	Access rights requests supported	a44	O	M	0,1	0,1
14	External handover supported	a45	O	M	0,1	0,1
15	Connection handover supported	a46	O	M	0,1	0,1
16	Reserved	a47	O	M	0,1	0,1
G.726: CCITT Recommendation G.726 [14].						

D.3.4 Procedure support

Table D.10: Procedures supported

Procedure supported				
Item No.	Name of Procedure	Ref.	PT Status	LT Status
1	Downlink continuous broadcast	9.1.1	M	M
21a	Basic bearer setup	10.5.1.1	M1	M1
22	A-field advanced single bearer setup	10.5.1.3	M2	M2
23	B-field single bearer setup	10.5.1.3	M3	M3
27	Duplex bearer handover procedure	10.6.2	O	M
29	Unacknowledge bearer release	10.7.2.1	O	M
36	Idle lock state entering procedure	10.6.2	O	X
37	Idle lock state maintaining procedure	10.6.2	O	X
40	Duplex bearer physical channel selection	11.4.1	X	-
41	Double simplex bearer physical channel selection	11.4.1	X	-
45a	RFP idle receiver scan sequence	11.8	O	M
45b	PP fast setup receiver scan sequence	11.9	O	X
46	Test message	12.2	M	M

D.3.5 CSF multiplexing functions

Table D.11: CSF multiplexing functions

CSF multiplexing functions				
Item No.	Name of function	Ref.	PT Status	LT Status
1	D-field MAP D80	6.2.1.1	Ca	Cb
2	D-field MAP D32	6.2.1.1	Ca	Cb
3	D-field MAP D08	6.2.1.1	Ca	Cb
4	D-field MAP D00	6.2.1.1	Ca	Cb
5	A-field MAP	6.2.1.2	M	M
6	B-field MAP D80 unprotected	6.2.1.3	Cc	Cd
7	B-field MAP D32 unprotected	6.2.1.3	Cc	Cd
8	B-field MAP D08 unprotected	6.2.1.3	Cc	Cd
9	B-field MAP D80 protected	6.2.1.3	Cc	Cd
10	B-field MAP D32 protected	6.2.1.3	Cc	Cd
11	B-field MAP D08 protected	6.2.1.3	Cc	Cd
12	Tail multiplexer	6.2.2.1	M	M
13	E/U-mux E80	6.2.2.2	Ce	Cf
14	E/U-mux E32	6.2.2.2	Ce	Cf
15	E/U-mux E08	6.2.2.2	Ce	Cf
16	E/U-mux U80a	6.2.2.2	Ce	Cf
17	E/U-mux U32a	6.2.2.2	Ce	Cf
18	E/U-mux U08a	6.2.2.2	Ce	Cf
19	E/U-mux U80b	6.2.2.2	Ce	Cf
20	E/U-mux U32b	6.2.2.2	Ce	Cf
21	E/U-mux U08b	6.2.2.2	Ce	Cf
32	C-mux Double Slot mode 10	6.2.2.3.1	C3g	C3g
37	C-mux Full Slot mode 4	6.2.2.3.1	C3h	C3h
39	C-mux Half Slot mode 1	6.2.2.3.2	C3i	C3i
40	Encryption	6.2.3	O	O
41	Scrambling	6.2.4	M3	M3
42a	A-field R-CRC generation	6.2.5.2	M	M
42b	B-field R-CRC generation	6.2.5.2	M3	M3
43a	A field R-CRC checking	6.2.5.2	M	M
43a	B-field R-CRC checking	6.2.5.2	M3	M3
44	X-CRC generation	6.2.5.4	M	M
45	X-CRC checking	6.2.5.4	M	O
46	Broadcast control function	6.2.6	-	M
<p>For A-field setups (i.e. type 1 and 2): only A-field R-CRC is mandatory.</p> <p>Ca: At least one shall be supported by the EUT.</p> <p>Cb: At least one shall be supported by the LT.</p> <p>Cc: At least one shall be supported by the EUT.</p> <p>Cd: At least one shall be supported by the LT.</p> <p>Ce: At least one shall be supported by the EUT.</p> <p>Cf: At least one shall be supported by the LT.</p> <p>C3g: Mandatory if double slot supported.</p> <p>C3h: Mandatory if full slot supported.</p> <p>C3i: Mandatory if half slot supported.</p>				

D.3.6 Timer and counter support

Those timers and counters required by the mandatory procedures are classified as mandatory (see table D.10).

D.4 Capabilities of FP (EUT) under test

D.4.1 Services

Table D.12: Broadcast services

Broadcast services supported				
Item No.	Name of service	Ref.	FT Status	LT Status
1	Continuous broadcast	5.7.1.1	M	M
2	System identities	5.7.1.1	O	M
3	System information	5.7.1.1	M	M

D.4.2 Messages

Table D.13: Header field messages

Header-field messages						
Item No.	Message	Ref.	Sending		Receipt	
			FT Status	LT Status	FT Status	LT Status
3	Identities information on C/L bearer	7.1.2	O	-	-	M
4	Identities information	7.1.2	M	M	M	M
5	Multiframe synchronization and system information	7.1.2	M	-	-	M
6	Escape	7.1.2	X	X	I	-
7	MAC layer control	7.1.2	M	M	M	M
9	First PP transmission	7.1.2	-	M	M	-
12	U-type, IN, SIN or IP packet number 0	7.1.4	M	M	M	M
16	E-type, not all CF or CLF ; packet number 0	7.1.4	C3a	C3b	C3a	C3b
17	E-type, not all CF ; CF packet number 1	7.1.4	C3a	C3b	C3a	C3b
18	E-type, all MAC control (unnumbered)	7.1.4	C3a	C3b	C3a	C3b
19	No B-field	7.1.4	O	O	O	M
C3a: At least one of the set is mandatory for the EUT.						
C3b: At least one of the set is mandatory for the LT.						

Table D.14: Messages in the A-tail field

Messages in the A-tail field						
Item No.	Message	Ref.	Sending		Receipt	
			FT Status	LT Status	FT Status	LT Status
1	Identities information	7.2.2	O	M	O	M
2	Static system information	7.2.3.2	M	-	-	M
3	Extended RF carrier information	7.2.3.3	X	-	-	I
4	Fixed part capabilities	7.2.3.4	O	-	-	M
8	Q-channel escape	7.2.3.8	O	-	-	X
31	Basic CC access request	7.2.5.2.2	-	M1	M1	-
32	Basic CC bearer handover request	7.2.5.2.2	-	X	I	-
33	Basic CC connection handover request	7.2.5.2.2	-	X	I	-
34	Basic CC unconfirmed access request	7.2.5.2.2	-	X	I	-
35	Basic CC bearer confirm	7.2.5.2.2	M1	-	-	M1
36	Basic CC bearer release	7.2.5.2.2	O	M1	M1	M1
37	Basic CC wait	7.2.5.2.3	O	M1	O	M1
38	Advanced CC access request	7.2.5.3.2	O	M2	M2	O
39	Advanced CC bearer handover request	7.2.5.3.3	-	X	I	-
40	Advanced CC connection handover request	7.2.5.3.4	O	X	I	O
41	Advanced CC unconfirmed access request	7.2.5.3.5	O	X	I	O
42	Advanced CC bearer confirm	7.2.5.3.6	M2	O	O	M2
43	Advanced CC wait	7.2.5.3.7	O	M2	O	M2
44	Advanced CC attributes_T, request	7.2.5.3.8	O	M2	M2	O
45	Advanced CC attributes_T, confirm	7.2.5.3.8	M2	O	O	M2
46	Advanced CC bandwidth_T, request	7.2.5.3.9	O	X	O	O
51	Advanced CC release	7.2.5.3.13	O	M2	M2	M2
52	MAC test force transmit	7.2.5.4.2	-	X	-	-
53	MAC test loopback data	7.2.5.4.3	-	M	M	-
54	MAC test defeat antenna diversity	7.2.5.4.4	-	M	M	-
55	MAC test force bearer handover	7.2.5.4.5	X	X	I	I
56	MAC test escape	7.2.5.4.6	X	X	I	I
57	MAC test network test	7.2.5.4.7	X	I	I	I
58	MAC test clear test modes	7.2.5.4.8	-	M	M	-
79	Encryption request	7.2.5.7	-	O	O	-
80	Encryption confirm	7.2.5.7	O	-	-	O
81	Encryption grant	7.2.5.7	-	O	O	-
82	B-field setup, first PT transmission	7.2.5.8	-	M3	M3	-
83	MAC control escape	7.2.5.9	O	X	I	O

Table D.15: Messages in the B-tail field

Messages in the B-tail field						
Item No.	Message	Ref.	Sending		Receipt	
			FT Status	LT Status	FT Status	LT Status
1	Advanced CC access request	7.3.3.2	O	M3	M3	O
2	Advanced CC bearer handover request	7.3.3.2	-	X	O	-
3	Advanced CC connection handover request	7.3.3.2	O	X	O	O
4	Advanced CC unconfirmed access request	7.3.3.2	O	X	O	O
5	Advanced CC bearer confirm	7.3.3.3	M3	O	O	M3
6	Advanced CC wait	7.3.3.4	O	M3	O	M3
14	Advanced CC release	7.3.3.10	O	M3	M3	M3
30	B-field escape	7.3.8	O	X	I	X

D.4.3 Message parameters

The slot type shall be set correctly in all message parameters.

The equipment supplier shall provide message parameter details for configuring the LT.

Table D.16: Parameters for A-field static system information message

Parameters for A-field static system information message						
Item No.	Name of parameter	Ref.	FT Status	LT Status	Values	
					FT Allowed	LT Allowed
1	Normal-reverse	7.2.3.2.2	M	M	0,1	0,1
2	Slot number	7.2.3.2.3	M	M	0-11	0-11
3	Start position	7.2.3.2.4	M	M	0,2	0,2
4	QT escape bit	7.2.3.2.5	M	M	0,1	0,1
5	Number of transceivers	7.2.3.2.6	M	M	0-3	0-3
6	Extended RF carrier information available	7.2.3.2.7	M	M	0,1	0,1
7	RF carriers available	7.2.3.2.8	M	M	1-1023	1-1023
8	Carrier number	7.2.3.2.10	M	M	0-9	0-9
9	Primary receiver scan carrier number	7.2.3.2.12	M	M	0-9	0-9

NOTE: Slot number, carrier number and primary receive scan carrier number shall be dynamically set by the EUT.

Table D.17: Parameters for MAC FP capability message

Parameters for A-field MAC FP capability message						
Item No.	Name of parameter	Ref.	FT Status	LT Status	Values	
					FT Allowed	LT Allowed
1	Extended Fixed Part information	7.2.3.4.2	O	M	0,1	0
2	Double slot	7.2.3.4.2	O	M	0,1	0,1
3	Half slot	7.2.3.4.2	O	M	0,1	0,1
4	Full slot	7.2.3.4.2	O	M	0,1	0
5	Frequency control	7.2.3.4.2	O	M	0,1	0
6	Page repetition	7.2.3.4.2	O	M	0,1	0
7	C/O setup on dummy bearer allowed	7.2.3.4.2	O	M	0,1	0
8	C/L uplink	7.2.3.4.2	O	M	0,1	0
9	C/L downlink	7.2.3.4.2	O	M	0,1	0
10	Basic A-field setup	7.2.3.4.2	O	M1	0,1	0,1
11	Advanced A-field setup	7.2.3.4.2	O	M2	0,1	0,1
12	B-field setup	7.2.3.4.2	O	M3	0,1	0,1
13	CF messages	7.2.3.4.2	O	M	0,1	0,1
14	IN minimum delay	7.2.3.4.2	O	M	0,1	0
15	IN normal delay	7.2.3.4.2	O	M	0,1	0,1
16	IP error detection	7.2.3.4.2	O	M	0,1	0,1
17	IP error correction	7.2.3.4.2	O	M	0,1	0,1
18	Multibearer connections	7.2.3.4.2	O	M	0,1	0,1

Table D.18: Parameters for higher layer information FP capability message
(ref. ETS 300 175-5 [5], annex F)

Parameters for A-field higher layer information FP capability message						
Item No.	Name of Parameter	Ref.	FT Status	LT Status	Values	
					FT Allowed	LT Allowed
1	ADPCM/G.726 Voice service	a32	O	M	0,1	0,1
2	Public Access Profile (PAP) supported	a33	O	M	0,1	0,1
3	Non-voice circuit switched service	a34	O	M	0,1	0,1
4	Non-voice packet switched service	a35	O	M	0,1	0,1
5	Standard authentication required	a36	O	M	0,1	0,1
6	Standard ciphering supported	a37	O	M	0,1	0
7	Location registration supported	a38	O	M	0,1	0,1
8	SIM services available	a39	O	M	0,1	0,1
9	Non-static Fixed Part (FP)	a40	O	M	0,1	0,1
10	CISS services available	a41	O	M	0,1	0,1
11	CLMS services available	a42	O	M	0,1	0,1
12	COMS services available	a43	O	M	0,1	0,1
13	Access rights requests supported	a44	O	M	0,1	0,1
14	External handover supported	a45	O	M	0,1	0,1
15	Connection handover supported	a46	O	M	0,1	0,1
16	Reserved	a47	O	M	0,1	0,1

G.726: CCITT Recommendation G.726 [14].

D.4.4 Procedure support

Table D.19: Procedures supported

Procedure supported				
Item No.	Name of procedure	Ref.	FT Status	LT Status
1	Downlink continuous broadcast	9.1.1	M	M
21a	Basic bearer setup	10.5.1.1	M1	M1
22	A-field advanced single bearer setup	10.5.1.3	M2	M2
23	B-field single bearer setup	10.5.1.3	M3	M3
27	Duplex bearer handover procedure	10.6.2	I	X
29	Unacknowledge bearer release	10.7.2.1	M	M
40	Duplex bearer physical channel selection	11.4.1	-	X
41	Double simplex bearer physical channel selection	11.4.1	-	X
42	Simplex bearer physical channel selection	11.4.1	-	X
45	RFP idle receiver scan sequence	11.8	M	M
46	Test message	12	M	M

D.4.5 CSF multiplexing functions

Table D.20: CSF multiplexing functions

CSF multiplexing functions				
Item No.	Name of function	Ref.	FT Status	LT Status
1	D-field MAP D80	6.2.1.1	Ca	Cb
2	D-field MAP D32	6.2.1.1	Ca	Cb
3	D-field MAP D08	6.2.1.1	Ca	Cb
4	D-field MAP D00	6.2.1.1	Ca	Cb
5	A-field MAP	6.2.1.2	M	M
6	B-field MAP D80 unprotected	6.2.1.3	Cc	Cd
7	B-field MAP D32 unprotected	6.2.1.3	Cc	Cd
8	B-field MAP D08 unprotected	6.2.1.3	Cc	Cd
9	B-field MAP D80 protected	6.2.1.3	Cc	Cd
10	B-field MAP D32 protected	6.2.1.3	Cc	Cd
11	B-field MAP D08 protected	6.2.1.3	Cc	Cd
12	Tail multiplexer	6.2.2.1	M	M
13	E/U-mux E80	6.2.2.2	Ce	Cf
14	E/U-mux E32	6.2.2.2	Ce	Cf
15	E/U-mux E08	6.2.2.2	Ce	Cf
16	E/U-mux U80a	6.2.2.2	Ce	Cf
17	E/U-mux U32a	6.2.2.2	Ce	Cf
18	E/U-mux U08a	6.2.2.2	Ce	Cf
19	E/U-mux U08a	6.2.2.2	Ce	Cf
20	E/U-mux U32b	6.2.2.2	Ce	Cf
21	E/U-mux U08b	6.2.2.2	Ce	Cf
32	C-mux DS mode 10	6.2.2.3.1	C3g	C3g
37	C-mux FS mode 4	6.2.2.3.1	C3h	C3h
39	C-mux HS mode 1	6.2.2.3.2	C3i	C3i
40	Encryption	6.2.3	O	O
41	Scrambling	6.2.4	M3	M3
42a	A field R-CRC generation	6.2.5.2	M	M
42b	B-field R-CRC generation	6.2.5.2	M3	M3
43a	A-field R-CRC checking	6.2.5.2	M	M
43b	B-field R-CRC checking	6.2.5.2	M3	M3
44	X-CRC generation	6.2.5.4	M	M
45	X-CRC checking	6.2.5.4	O	O
46	Broadcast control function	6.2.6	M	-
<p>For A-field setups (i.e. type 1 and 2): only A-field R-CRC is mandatory.</p> <p>Ca: At least one shall be supported by the EUT.</p> <p>Cb: At least one shall be supported by the LT.</p> <p>Cc: At least one shall be supported by the EUT.</p> <p>Cd: At least one shall be supported by the LT.</p> <p>Ce: At least one shall be supported by the EUT.</p> <p>Cf: At least one shall be supported by the LT.</p> <p>C3g: Mandatory if double slot supported.</p> <p>C3h: Mandatory if full slot supported.</p> <p>C3i: Mandatory if half slot supported.</p>				

D.4.6 Timer and counter support

Those timers and counters required by the mandatory procedures are classified as mandatory, (see table D.19).

Annex E (normative): Measurement of BER

The LT shall use the following method for calculating BER:

- in frames counted for synchronization loss the bit errors for the frame shall be disregarded;
- only whole numbers of frames shall be tested;
- the threshold used in the EUT to detect synchronization shall be the same for BER measurements as for normal operation;
 - let the total number of frames transmitted by the LT be α ; and
 - let the number of frames counted with synchronization loss be β ; and
 - let the number of bits counted in error be γ ; and
 - Let the number of bits in a frame be ξ ;

then:

$$\text{BER} = \frac{\gamma}{\xi \times (\alpha - \beta)} \quad (4)$$

Over the measurement, β shall be less than 5 % of α .

For the calculation of the BER the following number N of transmitted bits shall be used:

$$N = (320 + 2\,016 \times (1 - e^{-\text{BER1}/\text{BERL}}))/\text{BERL}$$

where:

BERL - Limit value of BER measurement (depending on test case)

BER1 - BER measured during the first 320 000 bits (for BERL = 0,001) or 32 000 000 bits (for BERL = 0,00001) respectively. If BER1 is greater than BERL then BER1=BERL is used for the calculation.

Annex F (informative): Procedures for the measurement of synchronization loss at the EUT by the LT

F.1 Description

Clause 13 requires the synchronization loss to be measured within the LT. In order that this can be made possible this annex describes a method by which the EUT can inform the LT when a synchronization error has occurred.

F.2 Method

When a synchronization error occurs the EUT should either:

- 1) re-transmit the last received B-field; or
- 2) transmit all 0's in the B-field;

of the transmit half frame immediately following the loss of synchronization.

The LT should detect the synchronization error by using a threshold method on the bit error count for the frame. If the BER calculated for the frame is less than 25 % then the BER calculated should go towards the total bit error count for the measurement. If the BER calculated is greater than or equal to 25 % then the frame is counted as a synchronization error and the total bit error count is not incremented.

Annex G (normative): Requirements for PPs with direct PP to PP communication mode

PPs are not attached to a public network when operating in a direct PP to PP communication mode. Therefore only TBR 6 testing is mandatory for this mode of operation (see annex A). In addition it may be tested according to a specific interoperability profile (e.g. GAP).

G.1 Description of operation in direct PP to PP communication mode

Most PPs will be able to operate also in the normal non-direct communication mode. In this case the direct mode will be temporary, and all PPs in a group of PPs intended to communicate in direct communication mode have to be manually switched into this mode, since a PP in non-direct mode can only receive paging information from the system to which it is locked.

The access rights class E and related PARK E are reserved for direct communication only, see ETS 300 175-6 [6] second edition, subclauses 5.5, 6.1.5 and 6.3.2. The Access Rights Identity (ARI) class E requires a key pad entry of only 5 digits to provide all identity and subscription data required to form a group of PPs for direct communication. The use of class E identities is normally of temporary nature and does not contain an ETSI distributed code.

When there is no communication all PPs are active unlocked, no (dummy) bearer transmission exists, and all PPs are regularly, e.g. every 10 seconds, scanning all access channels with carrier numbers $c < 10$, for a (dummy) bearer transmission with proper Radio Fixed Part Identity (RFPI). When a PP wants to initiate a connection, it acts like an RFP, selects a channel within carriers $c < 10$ and starts transmitting a simplex (dummy) bearer with the relevant page message and Q_T information. Only the paged PP is allowed to enter idle locked mode, and shall respond with a normal bearer setup. If ARI class E is used, the initiating PP is not required to perform receiver scanning, and the paged PP shall make the bearer set-up attempt on the channel pair where it received the paging and intracell handover is not possible. The initiating PP shall cease transmitting and revert to PP active unlocked state, if a duplex bearer has not been established within 20 seconds. The initiating PP, when acting as an RFP, is allowed to apply PP timer stability requirements and PP channel selection rules for simplex bearers. A PP entering RFP mode is also allowed to derive over the air slot synchronization from a "non ARI E" DECT system, e.g. a large office system.

G.2 Requirements

PPs in direct communication mode shall meet the PP requirements for normal non-direct communication with the amendments defined below.

G.2.1 Setting the PP in direct communications mode

The EUT shall be set in direct communications mode provided with proper identities. Entering and leaving the direct communications mode shall be made by manual key pad entries.

The applicant shall inform the test laboratory about applied identities and the value of T, see below.

When not processing a call, the EUT shall be in active unlocked PP state. When initiating a call the number of the wanted subscriber shall be entered via the key pad, and the EUT shall at off-hook enter the RFP active idle state continuously sending the page message for the wanted subscriber. See ETS 300 175-3 [3], subclause 4.3.

G.2.2 When the EUT has initiated a call

The EUT shall meet the RFP requirements with the following amendments:

- **general:**
 - a) operation is only allowed on carriers with numbers 0 to 9. See ETS 300 175-1 [1], subclause 7.1;
 - b) the applicant shall declare if identities class E are used, in which case the N_T message will not contain an ETSI distributed code. See subclause 16.2. last paragraph;
 - c) the EUT shall use FP or PP simplex bearer channel selection rules for the RFP active idle state. See subclause 17.1;
 - d) the 25 ppm PP timer stability requirements apply. See subclause 8.4;
 - d) the EUT is not required to do receiver scanning for ARI class E. See ETS 300 175-6 [6], subclause 5.5;
- **when in RFP active idle state:**
 - a) the page message shall be transmitted in every frame for at least T seconds;
 - b) the short page format shall be used for ARI class E;
 - c) the EUT shall revert to PP active unlocked state, if a duplex bearer has not been established within 20 seconds.

G.2.3 When the EUT has not initiated a call

- a) The EUT shall scan all channels on carriers $c < 10$ at least every T seconds.
- b) The EUT is only allowed to stay in idle locked state if it is being paged.
- c) If ARI class E is used, the paged EUT shall make the bearer set-up attempt on the channel pair where the initiating PP transmits.

Annex H (normative): Requirements for installation related issues

This annex contains requirements on installation related issues. These requirements may have impact on the type testing of specific EUTs, but will by its nature normally not be conformed to by type tests. They may be referred to in the conditions for licensed and unlicensed DECT installations. This annex includes installation related requirements from the DECT base standard ETS 300 175, parts 1 to 8 [1] to [8], and will be updated and expanded based on experience and evolving DECT applications.

H.1 Spectrum efficiency for speech transmission

The applicant shall declare that all provisions within the equipment capable of the transport of 3,1 kHz audio band speech always code the speech at rates not exceeding 32 kbit/s for transmission over the DECT air interface when transporting such traffic.

H.2 Antennas with directivity

For equipment with an integrated antenna, the antenna gain as measured using the procedure specified in subclause 10.2, shall not exceed 12 dBi plus the maximum allowable measurement uncertainty for absolute RF power (radiated) as given in subclause 5.8.5.

For equipment with an external antenna connector, the applicant shall supply customer documentation which makes clear that attachment to antennas with gain greater than 12 dBi, and not exceeding 22 dBi, requires permission from the national radio regulatory authority, and that attachment to antennas with gain greater than 22 dBi is not permitted.

NOTE: The antenna gain notation is in this context an expression for directing the emitted power, but not to increase the total emitted power. The total emitted power is always limited to 250 mW, independent of the antenna used. In systems with instant dynamic channel selection, gain antennas direct the signal in the wanted direction and decreases interference in the other directions, and makes the infrastructure more cost efficient.

H.3 DECT frame synchronization

DECT is designed not to require frame or slot synchronization between base stations or systems to maintain a high radio link quality. Synchronization between nearby base stations does however in general decrease the local load on the spectrum. For high capacity indoor multi-cell systems the vast majority of the base stations normally belong to the one system, and synchronization is regarded essential by manufacturers both to provide efficient handover and to meet internal system capacity requirements.

Intersystem synchronization (to an absolute reference or mutual) is essential for above rooftop high capacity applications, and should be mandated for such applications. Intersystem synchronization (to an absolute reference or mutual) is also essential for "hot spot" public Cordless Terminal Mobility (CTM) applications. For other cases inter system synchronization is typically not critical, and should not be mandated.

The DECT frame synchronization means for which tests are defined in clause 14 are:

- a) the "Synchronization Port" with master and slave requirements. This enables mutual synchronization;
- b) the "Integrated GPS Synchronization" function (not dependent on available synchronization port). It defines "GPS air" to "RFP air" time requirements, and provides absolute time synchronization. Such FPs shall set the GPS broadcast bit to 1, see further on "Air Synchronization";
- c) the "External GPS Synchronization" device, which is to be interfaced with a Synchronization Port operating in slave mode. It delivers a synchronization signal that fits the Synchronization Port operating in slave mode (which provides line delay compensation when needed). When connected to the Synchronization Port, the delay compensation of this Port is adjusted so that the "GPS air" to "RFP air" time requirements from b) are met.

A fourth means for synchronization is the "DECT Air Synchronization". This method implies that RFPs regularly scan the air interface for other systems and can synchronize their reference timers to an other system. A detailed description of this method is not included in the standard, but the basic requirements are found in this annex.

Table H.1 shows an overview of the most important characteristics for the different types of frame synchronization.

Table H.1

Type of synchronization	GPS Synchronization	Synchronization Port (wired) (note 3)	DECT Air Synchronization (note 3)
Independent of other operators	Yes	No	No
Absolute reference	Yes	No (note 1)	No (note 1)
Without temporarily loss of synchronization	Yes	Yes	No (note 2)
NOTE 1: Will be absolute if the master is locked to an absolute time reference. NOTE 2: Temporary loss of synchronization may not cause slot drifts if both master and slave have a stable clock (< 0,1 ppm). NOTE 3: The system shall avoid guard band violation and shall prevent any possibility to form a closed loop. See below.			

It is recommended that all public systems, i.e. all systems needing a license, are required to be locally synchronized to each other, if an operator requires it in a specific area. This implies that the means for mutual synchronization must be included in public systems. **Such requirements should be incorporated in the interoperability profile standards for the CAP; the RAP and for the public FPs in the GAP.**

In addition, intrasystem synchronization, at least within local clusters, should be mandatory for these profiles. Most systems already have intrasystem synchronization in order to provide intercell handover.

This leads to the following simple rule:

Public systems should provide intrasystem cluster synchronization, and should have either GPS Synchronization and a Synchronization output Port or a complete Synchronization Port (both input and output). This will allow absolute time synchronization via GPS or wired mutual synchronization, if an operator requires local synchronization between operators. Such requirements can be tested according to requirements in a profile.

NOTE: For CTM street type systems (antennas lamp post, below rooftop, 1E per base), synchronization may improve the capacity, but is often not essential. GPS synchronization is feasible if several base stations are part of the same FP. It is not cost effective for single RFP FPs connected directly to a local exchange unless it is possible to transfer frame synchronization signals via the local exchange.

H.3.1 Guidance for installation of frame synchronized DECT systems

H.3.1.1 GPS synchronization

The absolute "GPS air" to "RFP air" time relationship is defined in subclause 14.

The FP synchronized to a GPS reference shall indicate this by setting the GPS bit in the extended fixed part capabilities field equal to 1.

H.3.1.2 Wired synch port synchronization

DECT wired synch port synchronization requires careful co-ordination between adjacent systems for proper functionality. Lack of co-ordination may result in violation of the TBR 6 reference timer stability requirements (see annex A), and may prevent seamless intra-cell handover escapes from sliding interferes.

The master FP in the system should be the one with the most accurate timing reference. This will generally be a system locked to GPS or ISDN. This minimises the bit slip rate of user data in systems with digital network connections.

A master-slave chain is not allowed to form a closed loop

Careful consideration of the physical layout of systems is required. If a number of systems are chained together in such a way that the FPs at both ends of the chain are still physically close together, the guard bands may not be aligned, due to excess propagation delays in the synchronization chain. The largest difference of transmission start times of mutually interfering RFPs belonging to the same synchronization chain, shall not exceed 36 μ s (equivalent, under worst case to two cascaded synchronization links connected to the same master, see note 1). Use of star, rather than chain configurations may reduce the total propagation delay.

NOTE 1: Class 1 synchronization ports will produce a $\pm 9 \mu$ s uncertainty ($\pm 5 \mu$ s in the synchronization port and a further $\pm 4 \mu$ s timing variation between RFPs on the same FP). There can therefore be a $\pm 18 \mu$ s delay between two wire synchronized systems.

NOTE 2: There are situations where transmission start time difference of less than 36 μ s is required, e.g. long distance links and prolonged preamble.

H.3.1.3 Requirements for DECT air synchronization

DECT air synchronization requires careful co-ordination between adjacent systems for proper functionality. Lack of co-ordination may result in violation of the TBR 6 reference timer stability requirements (see annex A), and may prevent seamless intra-cell handover escapes from sliding interferes.

Air synchronization between systems is only allowed between RFPs.

The master FP in the system should be the one with the most accurate timing reference. This will generally be a system locked to GPS or ISDN. This minimises the bit slip rate of user data in systems with digital network connections.

A master-slave chain is not allowed to form a closed loop. Two systems must not attempt to lock to each other. With the present specification, the reference timer stability of a slave is controllable only for a single master slave link.

Annex I (informative): Essential requirements justification

Table I.1 provides a summary of the essential requirement articles of the Terminal Directive, 91/263/EEC [12] justifying the tests in this ETS.

Table I.1

Test Case	Test Case	Clause/ subclause number	Article
1	Accuracy and stability of RF carriers	7	4e
2	Timing jitter: slot-slot on the same channel	8.3	4e
3	no longer required		
4	Reference timing accuracy of a RFP	8.4	4e
4b	Measurement of packet timing accuracy	8.5	4e
5	Transmission Burst	9	4e
6	Transmitted power: PP and RFP with an integral antenna	10.2	4e
7	Transmitted power: PP and RFP with an external antenna connector	10.3	4e
8	RF carrier modulation	11	4e
9	Emissions due to modulation	12.2	4e
10	Emissions due to transmitter transients	12.3	4e
11	Emissions due to intermodulation	12.4	4e
12	Spurious emissions when allocated a transmit channel	12.5	4e
13	no longer required		
14	Radio receiver sensitivity	13.1	4e
15	Radio receiver bit error ratio	13.2	4e
16	Radio receiver interference performance	13.3	4e
17	Radio receiver blocking case 1	13.4	4e
18	Radio receiver blocking case 2	13.5	4e
19	Receiver intermodulation performance	13.6	4e
20	Spurious emissions when the radio endpoint has no allocated transmit channel	13.7	4e
21	Synchronization port	14	4e
22	EMC	15	4e
23	Equipment identity verification/safeguards	16	4e
24	Efficient use of radio spectrum	17	4e

Annex J (normative): Additions to ETS 300 175-2

J.1 Additional text on GPS synchronization

The following text will replace the current text (2nd edition 1996) of ETS 300 175-2 [2], clause C.5.

C.5 Synchronization by a GPS receiver integrated in the FP

The signal transmitted by a Global Positioning System (GPS) satellites indicates the GPS time, which is related but not equal to the Universal Time Co-ordinated (UTC). The GPS time should be considered as the standard time of the GPS system. In contrast with the UTC, the GPS time is not subject to leaped seconds. The GPS time provides an absolute time reference. This makes the GPS receiver time suitable for multiframe synchronization of DECT systems. Also multiframe number synchronization and Primary receiver Scan Carrier Number (PSCN) synchronization is derivable. Network layer messages are available to provide information on the level of synchronization provided between two FPs (ETS 300 175-5).

DECT systems are synchronized to the GPS timing by relating the start of the first frame of a multiframe to the GPS time. Since the time duration of a DECT multiframe is 160 ms, this implies that once every 4 seconds the start of a DECT multiframe coincides with an integer GPS second. For convenience, this is called a DECT hyperframe. The DECT hyperframe has a duration of 4 seconds and contains 25 DECT multiframes.

The relation between the DECT Internal System Sync signal and the (logical) GPS second timing is indicated in figure C.3a.

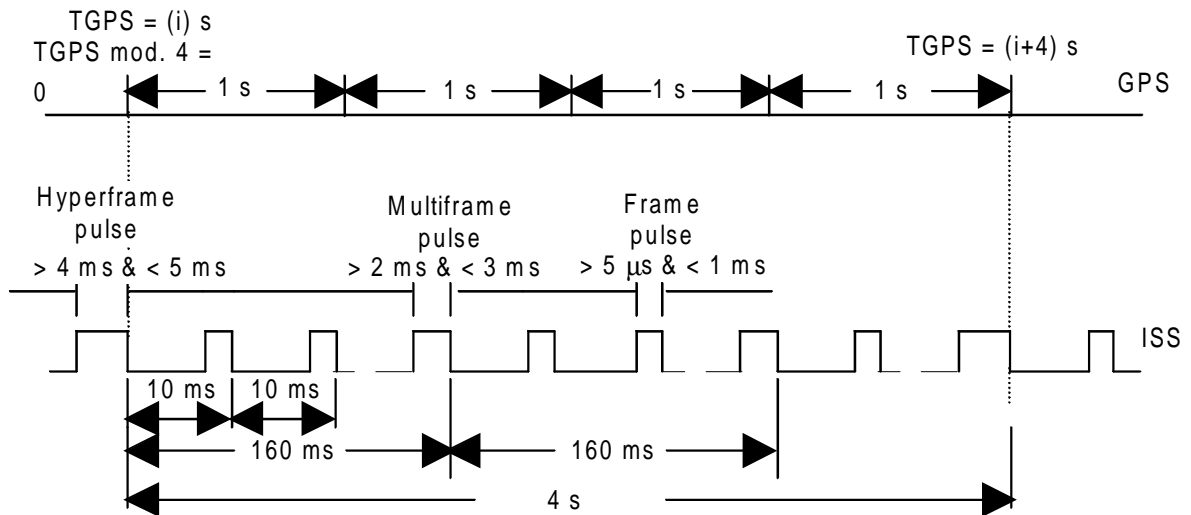

Figure C.3a: Relation between the GPS and the ISS timings

The random phase jitter on the falling edge of the Internal System Synchronization (ISS) signal shall not exceed 0,5 μs rms.

C.5.1 DECT multiframe time synchronization using GPS

The start of a DECT multiframe shall be related to the GPS time as follows:

$$T_{GPS} \bmod 4 = 0 ; \text{ This marks the start of a DECT hyperframe.}$$

A DECT FP synchronizing by means of a GPS receiver shall furthermore meet the timing requirements as specified for the DECT SYNC port (stated in clauses C.1 and C.2). The DECT Sync port interface requirements as specified in clauses C.1 and C.2 are only relevant if the FP provides a physical SYNC PORT output.

C.5.2 DECT multiframe-number synchronization using GPS

Multiframe number synchronization can only be established between two adjacent systems if they also have multiframe time synchronization. The Multi Frame Number of the first multiframe of a DECT hyperframe (starting at $T_{GPS} \bmod 4 = 0$) shall be related to the corresponding GPS time as follows:

$$MFN = \left(\frac{25}{4} T_{GPS} \right) \bmod 2^{24} \quad (5)$$

NOTE: The multiframe number consists of 24 bits in a MAC Q_T message (ETS 300 175-3, subclause 7.2.3.7).

C.5.3 DECT PSCN synchronization using GPS

The PSCN message (ETS 300 175-3, subclause 7.2.3.2.12) defines the RF carrier on which one receiver will be listening on the next frame when only one receiver is idle.

NOTE: PSCN synchronization is only possible if two systems use the same set of RF carriers and if the systems are at least multiframe time synchronized.

Assuming that N_C carriers are being used by both systems, this implies that all N_C carriers are scanned within a sequence of N_C frames (one carrier per frame). Since a hyperframe contains 400 frames, the minimum number of hyperframes at which the PSCN sequence repeats itself is given by:

$$N_H = \frac{N_C}{\text{LCD}(N_C, 400)} \quad (6)$$

where the notation $\text{LCD}(N_C, 400)$ denotes the Largest Common Denominator of N_C and 400.

When using GPS for synchronization of the PSCN, the PSCN of the first frame of the hyperframe starting at $T_{GPS} \bmod (4 \cdot N_H) = 0$ shall be equal to the RF carrier number corresponding with the lowest carrier frequency used by the system. Currently only 10 carriers in the frequency band 1 880-1 900 MHz are applied so $N_C = 10$ and $RF_L = 0$ (see ETS 300 175-3, subclause 7.2.3.2.12).

EXAMPLE 1: $N_C = 10$, Carrier no. 0 - 9 (current situation).

$N_H = 1$; In the first frame of each hyperframe at $T_{GPS} \bmod 4 = 0$, PSCN=0. It takes a maximum of 4 seconds before the PSCN can be synchronized.

EXAMPLE 2: $N_C=13$, Carrier no. 17-29 (fictitious future situation).

$N_H = 13$; In the first frame of each hyperframe at $T_{GPS} \bmod 52 = 0$. It takes a maximum of 52 seconds before the PSCN can be synchronized.

C.5.4 Envelope synchronization

For one RFP of the FP, the start of the DECT hyperframe on the air interface shall occur T_d μ s after the related logical GPS second. T_d defines the delay between the start of bit p0 in the first slot of the DECT frame at the RFP antenna, and the GPS timing.

- T_d is $15 \mu\text{s} \pm T_i \mu\text{s}$.
- T_i is $\pm 5 \mu\text{s}$ for Class 1.
- T_i is $\pm 2 \mu\text{s}$ for Class 2.

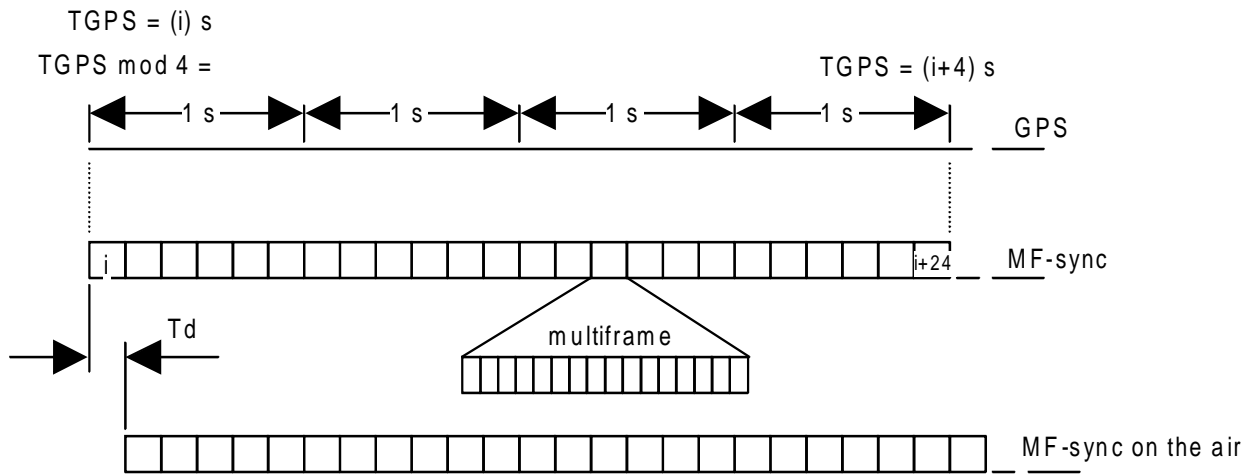

Figure C.3b: Relation between the GPS and the multiframe timings

C.6 External GPS synchronization device

The external GPS synchronization device is a device that retrieves DECT synchronization from the GPS system and provides a DECT SYNC PORT output signal that can be connected to a slave FP.

The timing and physical interface requirements for the SYNC PORT output of the device are reflected in subclauses C.1 and C.2, with the exception of the SYNC PORT output falling edge timing.

The falling edge of the SYNC PORT output of the device shall coincide within T_t μ s with the logical second pulse of the GPS timing (see figure C.3c.) enabling the device to be connected to a standard slave FP.

T_t is $\pm 5 \mu$ s for Class 1.

T_t is $\pm 2 \mu$ s for Class 2.

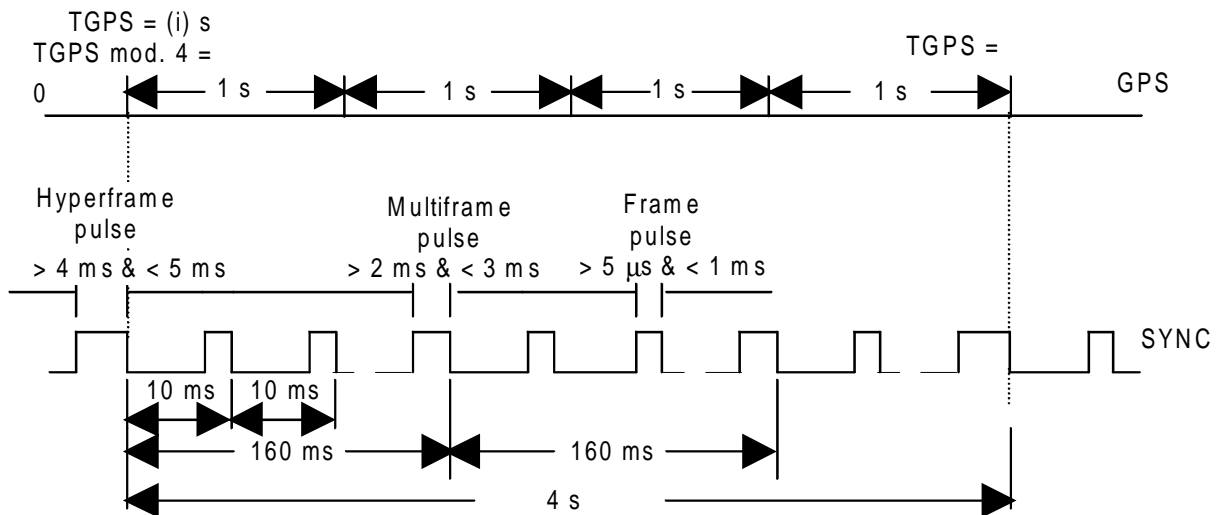

Figure C.3c: Relation between the GPS and the SYNC PORT output timing

C.7 DECT air synchronization

C.7.1 General

DECT air synchronization involves frame synchronizing to the bearer transmissions of other DECT systems.

DECT air synchronization requires careful co-ordination between adjacent systems for proper functionality. Lack of co-ordination may result in violation of the TBR 6 reference timer stability requirements (see annex A), and may prevent seamless intra-cell handover escapes from sliding interferes.

Co-ordination, via Operation, Administration and Maintenance (OA&M), is essential to ensure closed loops are not formed, and to ensure the FP acting as master, has the most accurate clock reference.

C.7.2 Specific requirements

Air synchronization between systems is only allowed between RFPs.

When lock is lost, the internal reference timer, meeting the TBR 6 requirements (see annex A), shall immediately act as reference timer. Lock will be regularly lost for short or longer time intervals due to bearer releases and blind slots.

When resynchronizing after a time interval of lost lock, the adjustment rate shall be less than 1 bit per 3 frames.

The transmissions of one RFP of the slave system shall have its slot and frame transmission time at the antenna adjusted within 5 μ s of the slot and frame timing of the DECT bearer to which it is trying to synchronize. The jitter shall be within $\pm 3 \mu$ s.

Equipment design shall ensure that the switchover between external synchronization source and internal reference timer (due to lost lock) does not disrupt the operation of the air interface.

Equipment design shall also ensure that disruption of the signal to which the equipment is attempting to synchronize, by any means (including loss of signal, non compliance with normal DECT frame structure etc.), does not disrupt the operation of the air interface. i.e. equipment shall be designed to ensure that an attempt to synchronize to an RFP which is not compliant to this ETS shall not cause the slave FP to be non-compliant.

NOTE: The above requirement is essential for proper operation of DECT systems, and may limit the use of air synchronization techniques.

History

Document history			
December 1993	First Edition		
October 1995	Public Enquiry	PE 94:	1995-10-23 to 1996-02-16
August 1996	Vote	V 109:	1996-08-12 to 1996-10-18