



EUROPEAN
TELECOMMUNICATION
STANDARD

ETS 300 175-9

September 1996

Second Edition

Source: ETSI TC-RES

Reference: RE/RES-03027-9

ICS: 33.060, 33.060.50

Key words: DECT, PAP, radio

**Radio Equipment and Systems (RES);
Digital Enhanced Cordless Telecommunications (DECT);
Common Interface (CI);
Part 9 : Public Access Profile (PAP)**

ETSI

European Telecommunications Standards Institute

ETSI Secretariat

Postal address: F-06921 Sophia Antipolis CEDEX - FRANCE

Office address: 650 Route des Lucioles - Sophia Antipolis - Valbonne - FRANCE

X.400: c=fr, a=atlas, p=etsi, s=secretariat - **Internet:** secretariat@etsi.fr

Tel.: +33 92 94 42 00 - Fax: +33 93 65 47 16

Copyright Notification: No part may be reproduced except as authorized by written permission. The copyright and the foregoing restriction extend to reproduction in all media.

© European Telecommunications Standards Institute 1996. All rights reserved.

Contents

Foreword	9
1 Scope.....	11
2 Normative references.....	11
3 Definitions and abbreviations	12
3.1 Definitions.....	12
3.2 Abbreviations	14
4 Features for the public access service.....	15
4.1 Description of the features	15
4.1.1 Speech	15
4.1.2 Bell on	15
4.1.3 Bell off	15
4.1.4 Off-hook	15
4.1.5 On-hook (full release)	15
4.1.6 Partial release.....	15
4.1.7 Dialed digits (basic).....	15
4.1.8 Dialed digits (additional)	16
4.1.9 Dialling delimiter	16
4.1.10 Dialling delimiter request	16
4.1.11 Register recall.....	16
4.1.12 Go to DTMF.....	16
4.1.13 Go to pulse	16
4.1.14 Pause (interdigit pause)	16
4.1.15 Specific trunk carrier selection	16
4.1.16 Incoming call	16
4.1.17 Hold call.....	16
4.1.18 Re-connection of a held call.....	16
4.1.19 Forced re-connection	16
4.1.20 Authentication of PP.....	17
4.1.21 Authentication of user.....	17
4.1.22 Authentication of FP.....	17
4.1.23 Silent polling.....	17
4.1.24 Class of service field indication	17
4.1.25 Inter-operator roaming registration.....	17
4.1.26 Control of supervisory tones	17
4.1.27 Regular security handshake.....	18
4.1.28 Signalling of display characters.....	18
4.1.29 Display control characters	18
4.1.30 ZAP suspend.....	18
4.1.31 ZAP terminate	18
4.1.32 Alphanumeric text messaging and radiopaging service	18
4.1.33 Voice and user data traffic encryption activation/deactivation	18
4.1.34 Signalling traffic encryption activation/deactivation	18
4.1.35 Debit public access service	18
4.1.36 Credit public access service	18
4.1.37 Credit agency public access service.....	19
4.1.38 On-demand (hot-bill) public access service	19
4.1.39 Advice of tariff request.....	19
4.1.40 Advice of charge request.....	19
4.1.41 Location registration for incoming calls, paging or messages.....	19
4.1.42 Location de-registration for incoming calls, paging or messages.....	19

4.1.43	Queue management.....	19
4.1.44	Queue entry request	19
4.1.45	Queue exit request.....	19
4.1.46	"Portable part inaccessible" indication.....	19
4.1.47	"In-range" indication	19
4.1.48	Emergency service access request	20
4.1.49	Indication of teleservices available request.....	20
4.1.50	Indication of teleservices available.....	20
4.1.51	Selection of service provider/network operator.....	20
4.1.52	Selection of required teleservice	20
4.1.53	Selection of bearer service	20
4.1.54	Validation of PP user.....	20
4.1.55	Validation of PP.....	20
4.1.56	Validation of identity module	20
4.1.57	User Personal Identification (UPI).....	20
4.1.58	Group address	20
4.1.59	Selection of additional character sets	21
4.1.60	Data capability.....	21
4.1.61	Keypad protocol for supplementary services.....	21
4.1.62	Feature key management protocol for supplementary services.....	21
4.1.63	Functional protocol for supplementary services	21
4.1.64	Dial tone detection indication.....	21
4.1.65	Request for indication of (temporary) subscriber number	21
4.1.66	PP capability/FP capability data exchange	21
4.1.67	Subscription registration user procedure (on-air)	21
4.1.68	Subscription registration user procedure (keypad).....	21
4.1.69	Subscription registration user procedure (DECT authentication module)	21
4.1.70	Subscription data exchange (on-air)	21
4.1.71	Multicell FP coverage.....	22
4.1.72	Handover	22
4.1.73	Multiple subscription registration	22
4.1.74	All-physical-channel capability	22
4.2	Summary of DECT public access service facilities.....	23
5	Effect of the services on the DECT layers.....	25
5.1	Overview of the affected DECT layers	25
5.2	Mapping of the features	27
5.2.1	Speech	27
5.2.2	Bell on	27
5.2.3	Bell off	27
5.2.4	Off-hook	28
5.2.5	On-hook (full release).....	28
5.2.6	Partial release	28
5.2.7	Dialled digits (basic).....	28
5.2.8	Dialled digits (additional).....	28
5.2.9	Dialling delimiter.....	28
5.2.10	Dialling delimiter request.....	28
5.2.11	Register recall	28
5.2.12	Go to DTMF.....	28
5.2.13	Go to pulse	29
5.2.14	Pause (interdigit pause).....	29
5.2.15	Specific trunk carrier selection	29
5.2.16	Incoming call	29
5.2.17	Hold call.....	29
5.2.18	Re-connection of a held call.....	29
5.2.19	Forced re-connection	29
5.2.20	Authentication of PP.....	29
5.2.21	Authentication of user.....	29
5.2.22	Authentication of FP.....	29
5.2.23	Silent polling	30

5.2.24	Class of service field indication	30
5.2.25	Inter-operator roaming registration.....	30
5.2.26	Control of supervisory tones	30
5.2.27	Regular security handshake.....	30
5.2.28	Signalling of display characters.....	30
5.2.29	Display control characters	30
5.2.30	ZAP suspend.....	30
5.2.31	ZAP terminate	30
5.2.32	Alphanumeric text messaging and radiopaging service.....	31
5.2.33	Voice and user data traffic encryption activation/deactivation	31
5.2.34	Signalling traffic encryption activation/deactivation	31
5.2.35	Debit public access service	31
5.2.36	Credit public access service	32
5.2.37	Credit agency public access service.....	32
5.2.38	On-demand (hot-bill) public access service	32
5.2.39	Advice of tariff request.....	32
5.2.40	Advice of charge request.....	32
5.2.41	Location registration for incoming calls, paging or messages.....	32
5.2.42	Location de-registration for incoming calls, paging or messages.....	32
5.2.43	Queue management.....	32
5.2.44	Queue entry request	33
5.2.45	Queue exit request	33
5.2.46	PP inaccessible indication.....	33
5.2.47	In-range indication	33
5.2.48	Emergency service access request.....	33
5.2.49	Indication of teleservices available request	33
5.2.50	Indication of teleservices available	33
5.2.51	Selection of service provider/network operator.....	33
5.2.52	Selection of required teleservice	33
5.2.53	Selection of bearer service	33
5.2.54	Validation of PP user	34
5.2.55	Validation of PP.....	34
5.2.56	Validation of identity module	34
5.2.57	User identification	34
5.2.58	Group address	34
5.2.59	Selection of additional character sets	34
5.2.60	Data capability	34
5.2.61	Keypad protocol for supplementary services.....	34
5.2.62	Feature key management protocol for supplementary services.....	34
5.2.63	Functional protocol for supplementary services	34
5.2.64	Dial tone detection indication	35
5.2.65	Request for indication of (temporary) subscriber number	35
5.2.66	Portable part capability/FP capability data exchange.....	35
5.2.67	Subscription registration user procedure (on-air)	35
5.2.68	Subscription registration user procedure (keypad).....	35
5.2.69	Subscription registration user procedure (DECT authentication module)	35
5.2.70	Subscription data exchange (on-air)	35
5.2.71	Multicell FP coverage.....	35
5.2.72	Handover	35
5.2.73	Multiple subscription registration	36
5.2.74	All-physical-channel capability.....	36
6	Requirements regarding the NWK layer.....	36
6.1	Required procedures	36
6.1.1	CC procedures.....	36
6.1.2	MM procedures	37
6.1.3	COMS procedures.....	37
6.1.4	CLMS procedures	37
6.1.5	LCE procedures	38
6.1.6	Supplementary service procedures	38

6.1.7	Management procedures.....	38
6.2	Required messages in the PT and FT.....	38
6.3	Required mandatory information elements	42
6.3.1	Information elements in CC messages.....	43
6.3.2	Information elements in CISS messages.....	47
6.3.3	Information elements in MM messages.....	48
6.4	Coding of information elements in CC messages.....	51
6.4.1	Coding of mandatory information elements in CC messages.....	51
6.4.2	Coding of optional information elements in CC messages.....	52
6.5	Coding of information elements in MM messages.....	53
7	Requirements regarding the DLC layer.....	53
7.1	Control plane.....	53
7.1.1	Minimum requirements	53
7.1.2	Incoming call (feature 16).....	53
7.1.3	Alphanumeric text messaging and radiopaging service (feature 32).....	54
7.2	User plane	54
8	Mandatory requirements regarding the MAC layer.....	54
8.1	MAC layer services.....	54
8.1.1	Connection oriented services	54
8.1.2	Broadcast services	54
8.2	MAC layer procedures.....	54
8.2.1	Connection oriented service procedures	54
8.2.1.1	General.....	54
8.2.1.2	Antenna diversity in connection oriented services	55
8.2.1.2.1	Q1 setting in direction PT to FT	55
8.2.1.2.2	Antenna change due to FT reception of Q1.....	55
8.2.1.2.3	Antenna change due to poor quality on slot received at FT	55
8.2.1.3	Information for handover.....	55
8.2.1.3.1	Q1 and Q2 setting in direction FT to PT.....	55
8.2.1.3.2	PT reception of Q1 and Q2	55
8.2.2	Broadcast procedures.....	56
8.3	Scrambling.....	56
8.4	Required messages.....	56
8.4.1	Header field.....	56
8.4.2	Messages in the tail field.....	57
8.4.2.1	Identities information (N_T tail).....	57
8.4.2.2	System information and multiframe marker (Q_T tail).....	57
8.4.2.3	Paging (P_T tail).....	57
8.4.2.4	MAC control (M_T tails)	57
8.4.3	Messages in the B-field.....	57
8.5	Monitoring of speech quality	57
9	MAC layer requirements for the optional features.....	58
9.1	Incoming call (feature 16).....	58
9.2	Alphanumeric text messaging and radiopaging service (feature 32).....	58
9.2.1	Alphanumeric service via the MAC broadcast service (case A)	58
9.2.2	Alphanumeric service via the MAC C/L downlink service (case B1)	59
9.2.3	Alphanumeric service via the MAC C/L downlink and uplink services (case B2)	59
9.3	Encryption (features 33 and 34).....	60
9.3.1	Connection oriented service procedures	60
9.3.2	System information and multiframe marker (Q_T tail)	60
9.3.3	MAC control (M_T tails)	60
9.4	Selection of bearer service (feature 53).....	60
9.5	TARI request.....	60
9.5.1	Non-continuous broadcast procedure.....	61

9.5.2	MAC control (M _T tails).....	61
10	Requirements regarding the Physical Layer (PHL).....	61
10.1	General	61
10.2	Minimum Normal Transmit Power (NTP).....	61
10.3	Radio receiver sensitivity.....	61
10.4	Z-field.....	61
10.5	Sliding collision detection.....	61
11	Requirements regarding the speech transmission.....	62
11.1	General	62
11.2	User controlled volume control.....	62
11.3	PP ambient noise rejection capability.....	62
Annex A (informative):	Message sequence diagrams.....	63
A.1	Outgoing call establishment.....	63
A.2	Incoming call establishment.....	64
A.3	Release initiated by the fixed termination.....	64
A.4	Release initiated by the portable termination.....	65
A.5	Location registration.....	65
Annex B (informative):	Set-up attributes codings.....	66
Annex C (informative):	DECT standard authentication algorithm.....	67
Annex D (informative):	DECT standard cipher.....	68
Annex E (informative):	Relationship to DECT Generic Access Profile (GAP).....	69
Annex F (informative):	Bibliography.....	70
History		71

Blank page

Foreword

This second edition European Telecommunication Standard (ETS) has been produced by the Radio Equipment and Systems (RES) Technical Committee of the European Telecommunications Standards Institute (ETSI).

This ETS forms part 9 of a series of 9 laying down the arrangements for the Digital Enhanced Cordless Telecommunications (DECT) Common Interface (CI).

- Part 1: "Overview".
- Part 2 "Physical layer (PHL)".
- Part 3 "Medium Access Control (MAC) layer".
- Part 4 "Data Link Control (DLC) layer".
- Part 5: "Network (NWK) layer".
- Part 6: "Identities and addressing".
- Part 7: "Security features".
- Part 8: "Speech coding and transmission".
- Part 9: "Public Access Profile (PAP)".**

Further details of the DECT system may be found in ETR 015, ETR 043, and ETR 056 (see annex F).

Transposition dates	
Date of adoption of this ETS:	6 September 1996
Date of latest announcement of this ETS (doa):	31 December 1996
Date of latest publication of new National Standard or endorsement of this ETS (dop/e):	30 June 1997
Date of withdrawal of any conflicting National Standard (dow):	30 June 1997

Blank page

1 Scope

This second edition European Telecommunication Standard (ETS) is part of the Digital Enhanced Cordless Telecommunications (DECT) Common Interface (CI) and specifies that set of technical requirements for DECT Fixed Parts (FPs) and Portable Parts (PPs) necessary for the support of the Public Access Service (PAS). It will also support other applications.

Apparatus for which DECT PAS capability is claimed has to comply with those technical requirements of this ETS which are identified as provision mandatory.

Apparatus claiming the provision of any optional service feature listed in this ETS has to fully comply with the corresponding process mandatory technical requirements.

2 Normative references

This ETS incorporates, by dated or undated reference, provisions from other publications. These normative references are cited at the appropriate places in the text and the publications are listed hereafter. For dated references, subsequent amendments to, or revisions of, any of these publications apply to this only when incorporated in it by amendment or revision. For undated references the latest edition of the publication referred to applies.

- [1] ETS 300 175-1 (1996): "Radio Equipment and Systems (RES); Digital Enhanced Cordless Telecommunications (DECT); Common Interface (CI); Part 1: Overview".
- [2] ETS 300 175-2 (1996): "Radio Equipment and Systems (RES); Digital Enhanced Cordless Telecommunications (DECT); Common Interface (CI); Part 2: Physical Layer (PHL)".
- [3] ETS 300 175-3 (1996): "Radio Equipment and Systems (RES); Digital Enhanced Cordless Telecommunications (DECT); Common Interface (CI); Part 3: Medium Access Control (MAC) layer".
- [4] ETS 300 175-4 (1996): "Radio Equipment and Systems (RES); Digital Enhanced Cordless Telecommunications (DECT); Common Interface (CI); Part 4: Data Link Control (DLC) layer".
- [5] ETS 300 175-5 (1996): "Radio Equipment and Systems (RES); Digital Enhanced Cordless Telecommunications (DECT); Common Interface (CI); Part 5: Network (NWK) layer".
- [6] ETS 300 175-6 (1996): "Radio Equipment and Systems (RES); Digital Enhanced Cordless Telecommunications (DECT); Common Interface (CI); Part 6: Identities and addressing".
- [7] ETS 300 175-7 (1996): "Radio Equipment and Systems (RES); Digital Enhanced Cordless Telecommunications (DECT); Common Interface (CI); Part 7: Security features".
- [8] ETS 300 175-8 (1996): "Radio Equipment and Systems (RES); Digital Enhanced Cordless Telecommunications (DECT); Common Interface (CI); Part 8: Speech coding and transmission".
- [9] I-ETS 300 176: "Radio Equipment and Systems (RES); Digital Enhanced Cordless Telecommunications (DECT) Approval test specification".
- [10] CCITT Recommendation G.721 (1988): "32 kbit/s adaptive differential pulse code modulation (ADPCM)".

3 Definitions and abbreviations

3.1 Definitions

For the purposes of this ETS, the following definitions apply:

antenna diversity: See ETS 300 175-1 [1].

attach: See ETS 300 175-1 [1].

authentication (of a subscriber): See ETS 300 175-1 [1].

bearer handover: See ETS 300 175-1 [1].

bearer service: See ETS 300 175-1 [1].

broadcast: See ETS 300 175-1 [1].

C-Plane: See ETS 300 175-1 [1].

call: See ETS 300 175-1 [1].

cell: See ETS 300 175-1 [1].

cluster: See ETS 300 175-1 [1].

connection handover: See ETS 300 175-1 [1].

Connectionless mode (C/L): See ETS 300 175-1 [1].

Connection Oriented mode (C/O): See ETS 300 175-1 [1].

Cordless Radio Fixed Part (CRFP): See ETS 300 175-1 [1].

coverage area: See ETS 300 175-1 [1].

DECT Network (DNW): See ETS 300 175-1 [1].

DLC data link (DLC link): See ETS 300 175-1 [1].

DLC frame: See ETS 300 175-1 [1].

double duplex bearer: See ETS 300 175-1 [1].

End System (ES): See ETS 300 175-1 [1].

external handover: See ETS 300 175-1 [1].

Fixed Part (DECT Fixed Part) (FP): See ETS 300 175-1 [1].

Fixed radio Termination (FT): See ETS 300 175-1 [1].

fragment: See ETS 300 175-1 [1].

fragmentation: See ETS 300 175-1 [1].

frame: See ETS 300 175-1 [1].

Global Network (GNW): See ETS 300 175-1 [1].

handover: See ETS 300 175-1 [1].

incoming call: See ETS 300 175-1 [1].

intercell handover: See ETS 300 175-1 [1].

internal handover: See ETS 300 175-1 [1].

interoperability: See ETS 300 175-1 [1].

interoperator roaming: See ETS 300 175-1 [1].

Interworking Unit (IWU): See ETS 300 175-1 [1].

intracell handover: See ETS 300 175-1 [1].

intraoperator roaming: See ETS 300 175-1 [1].

Local Network (LNW): See ETS 300 175-1 [1].

location area: See ETS 300 175-1 [1].

location registration: See ETS 300 175-1 [1].

logical channel: See ETS 300 175-1 [1].

Lower Layer Management Entity (LLME): See ETS 300 175-1 [1].

MAC bearer (bearer): See ETS 300 175-1 [1].

MAC connection (connection): See ETS 300 175-1 [1].

network (telecommunication network): See ETS 300 175-1 [1].

operator (DECT operator): See ETS 300 175-1 [1].

outgoing call: See ETS 300 175-1 [1].

paging: See ETS 300 175-1 [1].

paging area: See ETS 300 175-1 [1].

Portable Handset (PHS): See ETS 300 175-1 [1].

Portable Part (DECT Portable Part) (PP): See ETS 300 175-1 [1].

Portable radio Termination (PT): See ETS 300 175-1 [1].

private: See ETS 300 175-1 [1].

public: See ETS 300 175-1 [1].

Public Access Profile (PAP): See ETS 300 175-1 [1].

public access service: See ETS 300 175-1 [1].

radio end point: See ETS 300 175-1 [1].

Radio Fixed Part (RFP): See ETS 300 175-1 [1].

Repeater Part (REP): See ETS 300 175-1 [1].

roaming: See ETS 300 175-1 [1].

roaming service: See ETS 300 175-1 [1].

segment: See ETS 300 175-1 [1].

segmentation: See ETS 300 175-1 [1].

service provider (telecommunications service provider): See ETS 300 175-1 [1].

sequencing (sequence numbering): See ETS 300 175-1 [1].

Single Radio Fixed Part (SRFP): See ETS 300 175-1 [1].

subscriber (customer): See ETS 300 175-1 [1].

subscription registration: See ETS 300 175-1 [1].

Supplementary Service (SS): See ETS 300 175-1 [1].

TDMA frame: See ETS 300 175-1 [1].

telecommunication: See ETS 300 175-1 [1].

teleservice: See ETS 300 175-1 [1].

TPUI domain: See ETS 300 175-1 [1].

U-Plane: See ETS 300 175-1 [1].

user (of a telecommunication network): See ETS 300 175-1 [1].

Wireless Relay Station (WRS): See ETS 300 175-1 [1].

3.2 Abbreviations

For the purposes of this ETS the following abbreviations apply.

ADPCM	Adaptive Differential Pulse Code Modulation
ARI	Access Rights Identity
C/L	Connectionless mode
C/O	Connection Orientated mode
CC	Call Control
CI	Common Interface
CLMS	Connectionless Message Service
COMS	Connection Oriented Message Service
C-Plane	Control Plane
CRFP	Cordless Radio Fixed Part
DECT	Digital Enhanced Cordless Telecommunications
DLC	Data Link Control
DNW	DECT Network
DTMF	Dual Tone Multi-Frequency
ES	End System
FP	Fixed Part
FT	Fixed radio Termination
GNW	Global Network
IPUI	International Portable User Identity

IWU	Interworking Unit
LCE	Link Control Entity
LLME	Lower Layer Management Entity
LNW	Local Network
MM	Mobility Management
PAP	Public Access Profile
PARK	Portable Access Rights Key
PAS	Public Access Service
PHL	Physical, layer 1 of the DECT protocol stack
PHS	Portable Handset
PP	Portable Part
PT	Portable radio Termination
REP	Repeater Part
RFP	Radio Fixed Part
SRFP	Single Radio Fixed Part
SS	Supplementary Services
TDMA	Time Division Multiple Access
TM	Test Management
TPUI	Temporary Portable User Identity
UPI	User Personal Identification
U-Plane	User Plane
UT	Upper Tester
WRS	Wireless Relay Station

4 Features for the public access service

4.1 Description of the features

4.1.1 Speech

Circuit-mode 32 kbit/s unrestricted 8 kHz structured bearer service category suitable for speech information transfer (CCITT Recommendation G.721 (1988), [10]).

4.1.2 Bell on

Activates bell or other user indication controlling process at the target apparatus.

4.1.3 Bell off

Deactivates bell or other user indication controlling process at the target apparatus.

4.1.4 Off-hook

The ability to indicate the action of going off-hook, e.g. to start call set-up or accept a call.

4.1.5 On-hook (full release)

The ability to indicate the action of going on-hook (e.g. to terminate a call) and fully release the radio resource.

4.1.6 Partial release

The ability to release an established call whilst retaining the radio resource for the purpose of accessing further services.

4.1.7 Dialed digits (basic)

The capability to dial digits 0-9, *, #.

4.1.8 Dialed digits (additional)

The capability to dial digits A, B, C, D (in addition to the basic digits).

4.1.9 Dialling delimiter

A means to generate or otherwise to indicate "end-of-destination-address" when dialling or transmitting dialled digits.

4.1.10 Dialling delimiter request

The ability to advise that a dialling delimiter is required.

4.1.11 Register recall

To hold an existing call and seize a register (with dial tone) to permit input of further digits or other action.

4.1.12 Go to DTMF

Go to DTMF signalling, with optional indication of Dual Tone Multi-Frequency (DTMF) tone duration.

4.1.13 Go to pulse

Go to pulse (decadic) signalling.

4.1.14 Pause (interdigit pause)

The ability to generate or indicate an inter-digit pause, e.g. to await further dial tone.

4.1.15 Specific trunk carrier selection

The ability to select a specific trunk carrier for a call through a global network.

4.1.16 Incoming call

A call received at a DECT PP.

4.1.17 Hold call

The ability to hold calls while other services are accessed.

4.1.18 Re-connection of a held call

The re-connection of a previously held call.

4.1.19 Forced re-connection

The forced re-connection of a call which, e.g. has been left on hold for an excessive period of time.

4.1.20 Authentication of PP

The process by which the identity of a DECT PP is checked by the FP.

The standard (common) authentication algorithm shall be built-in to the cordless PP.

The standard (common) authentication algorithm shall be accepted for authentication of roaming public access service PP.

User authentication key and authentication code to be supported.

Time from initial request for service to completion of successful authentication process should not exceed 2 seconds.

4.1.21 Authentication of user

The process by which the identity of a DECT user is checked by the FP.

The User Personal Identification (UPI), a personal identification of 4 to 8 digits, manually entered by the user via the keypad, is used for user authentication.

4.1.22 Authentication of FP

The process by which the identity of a FP is checked by the PP.

It is optional to support the authentication of FT in both the PT and FT. If, however, ZAP, key management or PP data amendment is implemented in the FT then it is mandatory in the FT to support authentication of FT. The process is the same as that defined for authentication of PT.

User authentication key and authentication code to be supported.

NOTE: They are the same as those for PT, but different for each operator.

4.1.23 Silent polling

The ability of a DECT FP to establish whether a specific PP is within range without alerting the user of that PP.

4.1.24 Class of service field indication

Indication to the FP by the PP of the contents of its class-of-service field. The information passed across may vary depending on the system/network/service provider with whom communication is currently made, as class-of service may vary from one subscription to the other.

4.1.25 Inter-operator roaming registration

The ability to exchange inter-operator roaming data in real time over the air interface during the first call-attempt between the PP of a subscriber of a home DECT service provider A and the FP of a visited DECT service provider B, assuming A and B have agreed to offer inter-operator roaming to their respective subscribers.

4.1.26 Control of supervisory tones

Control of a variety of supervisory (call progress) tones, which may be generated in the PP.

For the public access service, network supervisory signals shall be made available in-band to the PP by the FP, either by relay from the global or extended services network, or by local generation at the PP.

The provision of a tone generator is optional for public access service PPs.

4.1.27 Regular security handshake

Regular interchange of information (link identifier) between PP and FP during the period between link initiation and link termination to maintain link in normal operation and to reject unauthorised attempts to seize link. Interchange at intervals of the order of 1 second is acceptable.

4.1.28 Signalling of display characters

The transmission to the PP of characters to be displayed on the user's PP display (if provided).

4.1.29 Display control characters

Characters sent to the PP to control the user's display in the PP (if provided). Such characters include cursor control, clear screen, home, flash, inverse video etc.

4.1.30 ZAP suspend

The ability to re-program the account data held in the PP so that access rights are suspended subject to the conditions set by the service provider being met, coupled with the ability to re-program the account data again to reinstate access rights once these conditions have been met. One ZAP field shall be provided per account field. The PP has the right to authenticate the FP prior to the execution of ZAP suspend.

4.1.31 ZAP terminate

The ability to re-program the account data held in the PP so that access rights are terminated and cannot be reinstated except by following a full re-registration procedure. Applications for this include the case where a PP requests access after a subscription has been cancelled or after the PP has been reported as lost or stolen. The PP has the right to authenticate the FP prior to the execution of ZAP terminate.

4.1.32 Alphanumeric text messaging and radiopaging service

The ability to send short messages consisting of up to 120 characters of the default or other character set or initiate tones when not in-call or when in-call, with or without acknowledgement.

4.1.33 Voice and user data traffic encryption activation/deactivation

The activation or deactivation of the encryption process applied to voice or user data on the traffic channel.

NOTE: This feature can be combined with signalling traffic encryption using a common encryption process.

4.1.34 Signalling traffic encryption activation/deactivation

The activation or deactivation of the encryption process on signalling information.

NOTE: This feature can be combined with voice and data traffic encryption using a common encryption process.

4.1.35 Debit public access service

A public access service system run on the basis of a PP being pre-loaded by some method with call-value for the system. A secure method of decrementing the call-value from the FP, under the control of the public access service operator, is required.

4.1.36 Credit public access service

A public access service system run on the basis of a PP being loaded by some means with identification data sufficient to enable the service provider to securely establish the account to which call charges are to be attributed.

4.1.37 Credit agency public access service

A public access service system run on the basis of a PP being loaded by some means with identification data sufficient to enable the service provider to securely establish the account with a credit agency to which call charges are to be attributed.

4.1.38 On-demand (hot-bill) public access service

A public access service system runs on the basis of a PP being loaded by some means with identification data sufficient to enable the service provider to securely establish the account to which call charges are to be attributed. At a billing point, the system has to be able to provide a bill for call charges accrued, on demand.

4.1.39 Advice of tariff request

The ability for the user to request an indication of the call tariff. The indication may be given by visual, audible or other means.

4.1.40 Advice of charge request

The ability for the user to request an indication of call charge for all or particular calls.

4.1.41 Location registration for incoming calls, paging or messages

A facility whereby a PP can be registered with a FP or a cluster of FPs such that incoming calls, radio pages or messages may be routed to it.

4.1.42 Location de-registration for incoming calls, paging or messages

A facility whereby a PP can be de-registered with a FP or a cluster of FPs.

4.1.43 Queue management

A facility to register in a queue, having been given a network congestion indication. Feed-back at regular intervals of information of how the queue is progressing may be provided by the alphanumeric messaging facility.

4.1.44 Queue entry request

Request to enter outgoing call queue.

4.1.45 Queue exit request

Request to exit the outgoing call queue.

4.1.46 "Portable part inaccessible" indication

An indication, based on information derived within the DECT FP to indicate that the called DECT PP cannot be contacted (not attached, not present, or powered down). This may be used to provide indication to the caller in some manner (e.g. by recorded message) that the call cannot be completed.

4.1.47 "In-range" indication

A means of indicating to a PP, without necessarily establishing a full two-way radio link, that it is within range of a FP to which it might wish to gain access.

4.1.48 Emergency service access request

A functional mode request for call set-up to the emergency service.

It shall be possible for the FP to discriminate an emergency service access request from non-emergency service access requests in order to ensure that it is possible to by-pass the normal call validation and establishment mechanisms if desired.

4.1.49 Indication of teleservices available request

Request to be given an indication of range of teleservices available at a given location.

4.1.50 Indication of teleservices available

Indication of the range of teleservices available at a given location.

4.1.51 Selection of service provider/network operator

The ability to signal the identity of the desired service provider or network operator with which it is desired to communicate when setting up a call at a particular moment in time.

4.1.52 Selection of required teleservice

The ability to select a particular teleservice which is required at a given moment.

4.1.53 Selection of bearer service

The ability to select a particular bearer service for a particular application for the duration or part of the duration of an individual call.

4.1.54 Validation of PP user

The process carried out by the DECT system/network to identify the class-of-service to be made available to an authenticated DECT user. This feature activates the class of service field indication.

4.1.55 Validation of PP

The process carried out by the DECT system/network to identify the class-of-service to be made available to an authenticated DECT PP. This feature activates the class of service field indication.

4.1.56 Validation of identity module

The process carried out by the DECT system/network to identify the class-of-service to be made available to an authenticated DECT authentication module. This feature activates the class of service field indication.

4.1.57 User Personal Identification (UPI)

The UPI, a personal identification of 4 to 8 digits, manually entered by the user via the keypad, used for user authentication only, which (having been operated on by the authentication key) generates an authentication result which is then passed over the radio interface and for example used to identify a user to a service provider. See authentication of user.

4.1.58 Group address

The ability to address a group of PPs for the purposes of simultaneous announcements e.g. through loudspeaking telephones.

4.1.59 Selection of additional character sets

The ability to select additional character sets.

4.1.60 Data capability

The ability to transmit and receive data traffic over a communications channel.

4.1.61 Keypad protocol for supplementary services

A protocol used to invoke supplementary services offered by the network to which DECT is interconnected.

4.1.62 Feature key management protocol for supplementary services

A protocol used to invoke supplementary services offered by the network to which DECT is interconnected.

4.1.63 Functional protocol for supplementary services

A protocol used to invoke supplementary services offered by the network to which DECT is interconnected.

4.1.64 Dial tone detection indication

The ability to indicate to the PP from the FP the detection of dial tone.

4.1.65 Request for indication of (temporary) subscriber number

A request to indicate (visually or audibly) to the user the temporary subscriber number allocated to the user during a temporary registration on (for example) a network, other than the usual or home network, to which the user has access rights.

4.1.66 PP capability/FP capability data exchange

The ability for a PP and a FP to exchange data on their respective capabilities so that each can establish the mutual subset which they have in common.

4.1.67 Subscription registration user procedure (on-air)

A standardised procedure for loading subscription registration data into a PP in real time over the air-interface.

4.1.68 Subscription registration user procedure (keypad)

A standardised procedure for loading subscription registration data into a PP using the keypad.

4.1.69 Subscription registration user procedure (DECT authentication module)

A standardised procedure for loading subscription registration data into a PP using the DECT authentication module.

4.1.70 Subscription data exchange (on-air)

The ability to exchange subscription data between a network and a PP in real-time over the air interface.

A secure subscription service shall be provided.

4.1.71 Multicell FP coverage

The ability of DECT to provide coverage using a FP comprising two or more cells with intercommunicating radio end points.

4.1.72 Handover

The action of switching a call in progress from one or more physical channels to other physical channel. There are two forms of handover, intracell handover and intercell handover:

- **intracell handover:** the switching of a call in progress from one or more physical channels of one cell to other physical channels of the same cell;
- **intercell handover:** the switching of a call in progress from one cell to another cell.

4.1.73 Multiple subscription registration

The ability for the PP to retain details of more than one subscription.

4.1.74 All-physical-channel capability

The capability of PPs and FPs to operate on all available DECT physical channels.

4.2 Summary of DECT public access service facilities

Those facilities listed below which are indicated as "provision mandatory" in either the PP, or FP, or both, represent the minimum public access service facility set.

- M mandatory;
- O optional;
- not applicable.

Table 1: Summary of DECT public access service facilities

		Provision		
		FP	PP	
0	Outgoing call	M	M	
1	Duplex speech - 32 kbit/s ADPC	M	M	
2	Bell on	O	O	(bell on/bell off shall be implemented as a pair)
3	Bell off	O	O	
4	Off hook	M	M	
5	On hook (full release)	M	M	
6	Partial release	M	O	
7	Dialled digits basic	M	M	
8	Dialled digits additional	O	O	
9	Dialling delimiter	O	O	
10	Dialling delimiter request	O	O	
11	Register recall	O	O	
12	Go to DTMF	M	O	
13	Go to pulse	O	O	
14	Pause	O	O	
15	Specific trunk carrier selection	O	O	
16	Incoming call	O	O	
17	Hold call	O	O	(hold call/re-connection of held call shall be implemented as a pair)
18	Re-connection of held call	O	O	
19	Forced re-connection of held call	O	O	
20	Authentication of portable part	M	M	
21	Authentication of user	O	M	Using UPI
22	Authentication of fixed part	M	O	Provision mandatory in FP if ZAP, key management or other PP data amendment feature implemented. Provision in PP recommended
23	Silent polling	O	O	
24	Class of service field indication	M	M	
25	Inter-operator roaming registration	O	M	
26	Control of supervisory tones	M	O	Provision mandatory only in fixed parts attached to networks offering out of band signalling
27	Regular security handshake	M	M	
28	Signalling of display characters	O	O	
29	Display control characters	O	O	
30	ZAP suspend	O	M	
31	ZAP terminate	O	M	
32	Alphanumeric text messaging and radiopaging service	O	O	
33	Voice/user data encryption activation/deactivation	O	O	
34	Signalling encryption activation/deactivation	O	O	
35	Debit public access service	O	O	
36	Credit public access service	O	O	
37	Credit agency public access service	O	O	
38	On-demand (hot-bill) public access service	O	O	
39	Advice of tariff request	O	O	

(continued)

Table 1 (concluded): Summary of DECT public access service facilities

		Provision		
		FP	PP	
40	Advice of charge request	O	O	
41	Location registration	O	O	
42	Location de-registration	O	O	Provision mandatory if, location registration for incoming calls is applied
43	Queue management	O	O	
44	Queue entry request	O	O	
45	Queue exit request	O	O	
46	Portable part inaccessible indication	O	-	Indicate to IWU that call cannot be connected.
47	In-range indication	O	O	
48	Emergency service access request	M	M	
49	Indication of teleservice available request	O	O	
50	Indication of teleservices available	O	O	
51	Selection of service provider/ network operator	M	M	
52	Selection of required teleservice	O	O	
53	Selection of bearer service	O	O	
54	Validation of portable part user	M	-	
55	Validation of portable part	M	-	
56	Validation of identity module	O	-	
57	User identification (UPI)	O	M	
58	Group address	O	O	
59	Selection of additional character sets	O	O	
60	Data capability	O	O	
61	Keypad protocol	M	M	
62	Feature key management protocol	O	O	
63	Functional protocol	O	O	
64	Dial tone detection indication	O	O	
65	Request for indication of temporary subscriber number	O	O	
66	Fixed part/portable part capability exchange	M	M	
67	Subscription registration user procedure on-air plus digit entry	M	M	
68	Subscription registration user procedures keypad (digit entry only)	O	O	
69	Subscription registration user procedure with DECT authentication module	O	O	
70	Subscription data exchange (on-air)	M	M	
71	Multicell fixed part coverage	O	M	
72	Handover (implicit in basic DECT)			
	- Intracell	M	M	
	- Intercell	O	M	
73	Multiple subscription registration	-	M	
74	All-physical-channel capability	M	M	

5 Effect of the services on the DECT layers

5.1 Overview of the affected DECT layers

Table 2: Overview of the affected DECT layers

	Features	MAC	DLC	Network Layer				ext app
				LCE	CC	CMS	MM	
0	Outgoing call	X	X	X	X	-	-	X
1	Duplex speech, ADPCM	u	u	-	-	-	-	X
2	Bell on	c	c	c	X	-	-	X
3	Bell off	c	c	c	X	-	-	X
4	Off hook	X	X	X	X	-	-	X
5	On hook (full release)	X	X	X	X	-	-	X
6	Partial release	c	c	X	X	-	-	X
7	Dialled digits basic	c	c	c	X	-	-	X
8	Dialled digits addit.	c	c	c	X	-	-	X
9	Dialling delimiter	c	c	c	X	-	-	X
10	Dialling delimiter request	c	c	c	X	-	-	X
11	Register recall	c	c	c	X	-	-	X
12	Go to DTMF	c	c	c	X	-	-	X
13	Go to pulse	c	c	c	X	-	-	X
14	Pause	c	c	c	X	-	-	X
15	Specific trunk carrier selection	c	c	c	X	-	-	X
16	Incoming call	X	X	X	X	-	X	X
17	Hold call	c	c	c	X	-	-	X
18	Reconnection of held call	c	c	c	X	-	-	X
19	Forced reconnection of held call	c	c	c	X	-	-	X
20	Authentication of portable part	c	c	c	-	-	X	-
21	Authentication of user	c	c	c	-	-	X	X
22	Authentication of fixed part	c	c	c	-	-	X	-
23	Silent polling	X	X	X	-	-	X	-
24	Class of service field indication	c	c	c	X	-	X	-
25	Inter-operator roaming registration	c	c	c	-	-	X	X
26	Control of supervisory tones	c	c	c	X	-	-	(X)
27	Regular security handshake	X	-	-	-	-	-	-
28	Signalling of display characters	c	c	c	X	-	-	X
29	Display control characters	c	c	c	X	-	-	X
30	ZAP suspend	c	c	c	-	-	X	(X)
31	ZAP terminate	c	c	c	-	-	X	(X)
32	Alphanumeric text messaging and radiopaging service	X	X	X	-	X	X	X
33	Voice/user data encryp. activation/deactivation	X	c	c	-	-	X	(X)
34	Signalling encryption activation/deactivation	X	c	c	-	-	X	(X)
35	Debit public access service	c	c	c	X	-	X	X
36	Credit public access service	-	-	-	-	-	-	X
37	Credit agency public access service	-	-	-	-	-	-	X
38	On-demand (hot-bill) public access service	c	c	c	X	-	-	X
39	Advice of tariff requ.	c	c	c	X	-	-	X
40	Advice of charge requ.	c	c	c	X	-	-	X
41	Location registration	c	c	c	-	-	X	(X)
42	Location deregistration	c	c	c	-	-	X	(X)

(continued)

Table 2 (concluded): Overview of the affected DECT layers

Features	MAC	DLC	Network Layer				ext app
			LCE	CC	CMS	MM	
43 Queue management	c	c	c	X	-	-	X
44 Queue entry request	c	c	c	X	-	-	X
45 Queue exit request	c	c	c	X	-	-	X
46 Portable part inaccessible indication	c	c	X	-	-	-	-
47 In-range indication	X	-	-	-	-	-	X
48 Emergency service access request	c	c	c	X	-	-	(X)
49 Indication of teleservice available req.	-	-	-	-	-	-	X
50 Indication of teleservice available	X	-	-	-	-	-	X
51 Selection of service provider/network oper.	X	-	-	-	-	-	X
52 Selection of required teleservice	c	c	c	X	-	-	X
53 Selection of bearer service	c	c	c	X	-	-	X
54 Validation of portable part user	-	-	-	-	-	-	X
55 Validation of portable part	-	-	-	-	-	-	X
56 Validation of identity module	-	-	-	-	-	-	X
57 User identification	c	c	c	-	-	X	X
58 Group address	c	c	X	-	X	-	-
59 Selection of additional character sets	c	c	c	X	-	-	X
60 Data capability	u	u	-	-	-	-	X
61 Keypad protocol	c	c	c	X	-	-	X
62 Feature key management protocol	c	c	c	X	-	-	X
63 Functional protocol	c	c	c	X	-	-	(X)
64 Dial tone detection indication	c	c	c	X	-	-	X
65 Request for indication of temporary subscriber number	c	c	c	X	-	-	X
66 Fixed part/port. part capability exchange	X	c	c	X	-	-	-
67 Subscription registr. user procedure on-air plus digit entry	-	-	-	-	-	-	X
68 Subscription registr. user procedure keypad (digit entry only)	-	-	-	-	-	-	X
69 Subscription registr. user procedure with DECT authent. module	-	-	-	-	-	-	X
70 On-air subscription Data Exchange	c	c	c	-	-	X	X
71 Multicell fixed part	-	-	-	-	-	-	X
72 Handover:							
b: bearer handover	X	-	-	-	-	-	-
c: connection handover	X	X	-	-	-	-	-
e: external handover	X	X	X	X	-	X	X
73 Multiple subscription registration	-	-	-	-	-	-	X
74 All-physical-channel capability	X	-	-	-	-	-	-
							X

MAC:

- X MAC layer is affected;
- c transmission of control plane data;
- u transmission of user plane data;
- no effect.

DLC:

- X DLC layer is affected;
- c transmission of control plane data;
- u transmission of user plane data;
- no effect.

LCE:

- X Link Control Entity (LCE) in the network layer is affected;
- c transmission of control plane data;
- u transmission of user plane data;
- no effect.

CC:

- X Call Control (CC) in the NWK layer is affected;
- Call Control (CC) in the NWK layer is not affected.

CMS:

- X Connectionless or Connection Oriented Message Service (COMS) in the NWK layer is affected;
- Connectionless or Connection Oriented Message Service (COMS) in the NWK layer is not affected.

MM:

- X Mobility Management (MM) in the NWK layer is affected;
- Mobility Management (MM) in the NWK layer is not affected.

ext app:

- X eXternal application is affected;
- (X) eXternal application may be affected;
- eXternal application is not affected.

NOTE: The external application includes all elements outside of the ETS 300 175 [1] to [8]. For example, this includes procedures in the Fixed Interworking unit the Portable application and the User interface.

5.2 Mapping of the features

This subclause describes how the features that are defined in clause 4 are mapped on to protocol elements and procedures. The provision of the feature itself can be optional or mandatory (as defined in clause 4) but whenever a feature is provided, the mapping shall be as defined in this subclause.

5.2.1 Speech

This feature is fully supported by the minimum set of public access protocol elements.

NOTE: The feature outgoing call (feature 0) is also fully supported by the minimum set of public access protocol elements.

5.2.2 Bell on

This feature shall be implemented by the minimum set of public access protocol elements plus the FT shall be able to send the <<signal>> information element with the coding "Alerting on - continuous" as specified in ETS 300 175-5 [5] and the PT shall be able to understand and react upon this information element.

5.2.3 Bell off

This feature shall be implemented by the minimum set of public access protocol elements plus the FT shall be able to send the <<signal>> information element with the coding "alerting off" as specified in ETS 300 175-5 [5] and the PT shall be able to understand and react upon this information element.

5.2.4 Off-hook

This feature is fully supported by the minimum set of public access protocol elements.

NOTE: This feature is implicitly supported by the CC-procedures.

5.2.5 On-hook (full release)

This feature is fully supported by the minimum set of public access protocol elements.

NOTE: This feature is implicitly supported by the CC-procedures.

5.2.6 Partial release

This feature shall be implemented by the minimum set of public access protocol elements plus a PT shall request partial release by using the appropriate coding of the "release reason" element when releasing the call. It should then maintain the link.

A FT shall respond to a request for partial release by maintaining the link for the maximum time allowed.

NOTE 1: The maximum link maintain time is defined by timer <LCE.02>. See ETS 300 175-5 subclause 14.2.7 [5].

NOTE 2: The PT may release the link before the expiry of <LCE.02>.

5.2.7 Dialed digits (basic)

This feature is fully supported by the minimum set of public access protocol elements.

5.2.8 Dialed digits (additional)

This feature shall be implemented by the minimum set of public access protocol elements plus the PT shall be able to send the <<single-keypad>> or <<multi-keypad>> information elements containing the DECT standard 8-bit character codings "a", "b", "c" and "d" and the FT shall be able to understand them.

NOTE: Additional dialed digits shall only use the lower-case letters "a", "b", "c" and "d".

5.2.9 Dialling delimiter

This feature shall be implemented by the minimum set of public access protocol elements plus the PT shall be able to send the <<sending complete>> information element as specified in ETS 300 175-5 [5] and the FT shall be able to understand this information element.

5.2.10 Dialling delimiter request

This feature shall be implemented by the minimum set of public access protocol elements plus the FT shall be able to send the <<delimiter request>> information element as specified in ETS 300 175-5 [5] and the PT shall be able to understand this information element.

5.2.11 Register recall

This feature shall be implemented by the minimum set of public access protocol elements plus the FT and PT shall support the CRSS feature key management protocol as specified in ETS 300 175-5 [5]. The PT and FT shall support the feature coding "register recall".

5.2.12 Go to DTMF

This feature shall be implemented by the minimum set of public access protocol elements plus the PT shall be able to send the <<single-keypad>> or <<multi-keypad>> information elements containing the DECT

standard 8-bit character codings "go to DTMF; defined tone length", "go to DTMF; infinite tone length" and "null" and the FT shall be able to understand them.

5.2.13 Go to pulse

This feature shall be implemented by the minimum set of public access protocol elements plus the PT shall be able to send the <<single-keypad>> or <<multi-keypad>> information elements containing the DECT standard 8-bit character coding "go to pulse" and the FT shall be able to understand them.

5.2.14 Pause (interdigit pause)

This feature shall be implemented by the minimum set of public access protocol elements plus the PT shall be able to send the <<single-keypad>> or <<multi-keypad>> information elements containing the DECT standard 8-bit character coding "dialling pause" and the FT shall be able to understand them.

5.2.15 Specific trunk carrier selection

This feature shall be implemented by the minimum set of public access protocol elements plus the FT and PT shall support the CRSS feature key management protocol (feature 15a) or CISS feature key management protocol (feature 15b) as specified in ETS 300 175-5 [5]. The PT and FT shall support the feature coding "specific trunk carrier selection".

5.2.16 Incoming call

This feature shall be implemented by the minimum set of public access protocol elements plus the elements of procedure which are indicated in clauses 6, 7 and 9 for this feature number 16 shall be fulfilled.

5.2.17 Hold call

This feature shall be implemented by the minimum set of public access protocol elements plus the FT and PT shall support the CRSS hold procedures as specified in ETS 300 175-5 [5].

5.2.18 Re-connection of a held call

This feature shall be implemented by the minimum set of public access protocol elements plus the FT and PT shall support the CRSS retrieve procedures as specified in ETS 300 175-5 [5].

5.2.19 Forced re-connection

This feature shall be implemented by the minimum set of public access protocol elements plus the FT and PT shall support the CRSS retrieve procedures as specified in ETS 300 175-5 [5].

5.2.20 Authentication of PP

This feature is fully supported by the minimum set of public access protocol elements.

NOTE: The necessary elements of procedure for this feature are indicated in clause 6.

5.2.21 Authentication of user

This feature shall be implemented by the minimum set of public access protocol elements plus the elements of procedure which are indicated in clause 6 for this feature number shall be fulfilled.

5.2.22 Authentication of FP

This feature shall be implemented by the minimum set of public access protocol elements plus the elements of procedure which are indicated in clause 6 for this feature number 22 shall be fulfilled.

5.2.23 Silent polling

This feature shall be implemented by the minimum set of public access protocol elements plus the elements of procedure which are indicated in clause 6 for this feature number 23 shall be fulfilled.

5.2.24 Class of service field indication

This feature shall be implemented by the minimum set of public access protocol elements plus the elements of procedure which are indicated in clause 6 for this feature number 24 shall be fulfilled.

5.2.25 Inter-operator roaming registration

This feature shall be implemented by the minimum set of public access protocol elements plus the elements of procedure which are indicated in clause 6 for this feature number 25 shall be fulfilled.

5.2.26 Control of supervisory tones

This feature shall be implemented by the minimum set of public access protocol elements plus the FT shall be able to send the <<signal>> information element as specified in ETS 300 175-5 [5] and the PT shall be able to understand and react upon this information element.

NOTE 1: Control of the dial tone is covered by the minimum requirements.

NOTE 2: The FT is only required to interwork equivalent message into <<signal>> information elements. Interworking of in-band tones into <<signal>> information elements is not required (but is allowed).

5.2.27 Regular security handshake

This feature is fully supported by the minimum set of public access protocol elements.

5.2.28 Signalling of display characters

This feature shall be implemented by the minimum set of public access protocol elements plus the FT shall be able to send <<single-display>> and <<multi-display>> information elements as specified in ETS 300 175-5 [5] and the PT shall be able to understand and react upon these information elements.

5.2.29 Display control characters

This feature shall be implemented by the minimum set of public access protocol elements plus the FT shall be able to send <<single-display>> and <<multi-display>> information elements as specified in ETS 300 175-5 [5] and the PT shall be able to understand and react upon these information elements.

5.2.30 ZAP suspend

This feature shall be implemented by the minimum set of public access protocol elements plus the elements of procedure which are indicated in clause 6 for this feature number 30 shall be fulfilled.

5.2.31 ZAP terminate

This feature shall be implemented by the minimum set of public access protocol elements plus the elements of procedure which are indicated in clause 6 for this feature number 31 shall be fulfilled.

For an extension of the feature where the procedure is initiated by the PT the elements of procedure which are indicated in clause 6 shall be fulfilled. In this case the feature is identified by the number "31p".

5.2.32 Alphanumeric text messaging and radiopaging service

Enhancement feature for further evolution of the ETS.

Depending on the required service (length of message, acknowledged or unacknowledged) three provisions are available, as shown in table 3.

Table 3

Network layer		Mac layer
Case A:	Connectionless message service	Broadcast (BS channel)
Case B:	Connectionless message service	Connectionless (CLF channel)
Case C:	Connection oriented message service	Connection (CS channel)

Case A can only support downlink messages;

Case B can support either downlink messages only (case B1) or downlink plus uplink messages (case B2);

Case C can support downlink and uplink messages.

NOTE: Case B2 can be used to provide an acknowledged service if acknowledgements are generated by the application (i.e. outside the DECT network service boundary).

In summary, the service requirements given in subclause 4.1.32 shall be mapped as follows:

Message Length:	≤ 20 chars	≤ 160 chars
Unacknowledged Point-multipoint	A (CLMS + BMC)	B1/B2 (CLMS + CBC)
Acknowledged Point-point	C (COMS + MBC)	C (COMS + MBC)

Downlink service mapping

NOTE: Location registration is necessary for services B1, B2 or C.

Message Length:	≤ 20 chars	≤ 160 chars
Unacknowledged Point-point	B2 (CLMS + BMC)	B2 (CLMS + CBC)
Acknowledged Point-point	C (COMS + MBC)	C (COMS + MBC)

Uplink Service mapping

5.2.33 Voice and user data traffic encryption activation/deactivation

This feature shall be implemented by the minimum set of public access protocol elements plus the elements of procedure which are indicated in clauses 6 and 9 for this feature number 33 shall be fulfilled.

5.2.34 Signalling traffic encryption activation/deactivation

This feature shall be implemented by the minimum set of public access protocol elements plus the elements of procedure which are indicated in clauses 6 and 9 for this feature number 33 shall be fulfilled.

5.2.35 Debit public access service

Enhancement feature for further evolution of the ETS.

NOTE: For the data transfer the parameter retrieval procedure can be used. To send information to the user the "cost information" supplementary service can be used.

5.2.36 Credit public access service

This feature is fully supported by the minimum set of public access protocol elements.

NOTE: For this service the IPU class "P" is used.

5.2.37 Credit agency public access service

This feature is fully supported by the minimum set of public access protocol elements.

NOTE: For this service the IPU class "Q" is used.

5.2.38 On-demand (hot-bill) public access service

This feature shall be implemented by the minimum set of public access protocol elements plus the FT and PT shall support the CRSS feature key management protocol (feature 38a) or the CISS feature key management protocol (feature 38b) as specified in ETS 300 175-5 [5]. The PT and FT shall support the feature coding "cost information".

The provision of the bill itself is a local application and does not affect the DECT layers.

5.2.39 Advice of tariff request

This feature shall be implemented by the minimum set of public access protocol elements plus the FT and PT shall support the CRSS feature key management protocol (feature 39a) or the CISS feature key management protocol (feature 39b) as specified in ETS 300 175-5 [5]. The PT and FT shall support the feature coding "cost information".

NOTE: The DECT specific supplementary service "cost information" is used to obtain information about the costs of either the DECT link alone or the combined costs of the DECT link plus the DECT external costs. The DECT standard supplementary service "advice of charge" is used to obtain information about the DECT external costs.

5.2.40 Advice of charge request

This feature shall be implemented by the minimum set of public access protocol elements plus the FT and PT shall support the CRSS feature key management protocol (feature 40a) or the CISS feature key management protocol (feature 40b) as specified in ETS 300 175-5 [5]. The PT and FT shall support the feature coding "cost information".

NOTE: The DECT specific supplementary service "cost information" is used to obtain information about the costs of either the DECT link alone or the combined costs of the DECT link plus the DECT external costs. The DECT standard supplementary service "advice of charge" is used to obtain information about the DECT external costs.

5.2.41 Location registration for incoming calls, paging or messages

This feature shall be implemented by the minimum set of public access protocol elements plus the elements of procedure which are indicated in clause 6 for this feature number 41 shall be fulfilled.

5.2.42 Location de-registration for incoming calls, paging or messages

This feature shall be implemented by the minimum set of public access protocol elements plus the elements of procedure which are indicated in clause 6 for this feature number 42 shall be fulfilled.

5.2.43 Queue management

This feature shall be implemented by the minimum set of public access protocol elements plus the FT and PT shall support the CRSS queue management procedure as specified in ETS 300 175-5 [5].

5.2.44 Queue entry request

This feature shall be implemented by the minimum set of public access protocol elements plus the FT and PT shall support the CRSS feature key management protocol as specified in ETS 300 175-5 [5]. The PT and FT shall support the feature coding "queue entry request".

5.2.45 Queue exit request

This feature shall be implemented by the minimum set of public access protocol elements plus the FT and PT shall support the CRSS queue management procedure as specified in ETS 300 175-5 [5].

5.2.46 PP inaccessible indication

This feature is fully supported by the minimum set of public access protocol elements.

5.2.47 In-range indication

This feature is fully supported by the minimum set of public access protocol elements.

5.2.48 Emergency service access request

This feature is fully supported by the minimum set of public access protocol elements.

5.2.49 Indication of teleservices available request

This feature is fully supported by the minimum set of public access protocol elements.

NOTE: The information is contained in the broadcast system information as "higher layer capabilities". It is an external application (terminal application) to give the information to the user.

5.2.50 Indication of teleservices available

This feature is fully supported by the minimum set of public access protocol elements.

NOTE: The information is contained in the broadcast system information as "higher layer capabilities".

5.2.51 Selection of service provider/network operator

This feature is fully supported by the minimum set of public access protocol elements.

NOTE: Implementation of this feature requires the means to enable the user to select a PARK so as to choose from available broadcast ARI's.

5.2.52 Selection of required teleservice

This feature is fully supported by the minimum set of public access protocol elements.

NOTE: The selection is done during the NWK layer CC call establishment. It is defined by sending the <<IWU attributes>> information element.

5.2.53 Selection of bearer service

This feature is fully supported by the minimum set of public access protocol elements.

NOTE: The selection is done during the NWK layer CC call establishment.

5.2.54 Validation of PP user

This feature is a local implementation and does not effect the DECT layers.

5.2.55 Validation of PP

This feature is a local implementation and does not effect the DECT layers.

5.2.56 Validation of identity module

This feature is a local implementation and does not effect the DECT layers.

5.2.57 User identification

This feature shall be implemented by the minimum set of public access protocol elements plus the elements of procedure which are indicated in clause 6 for this feature number 57 shall be fulfilled.

5.2.58 Group address

Enhancement feature for further evolution of the ETS.

NOTE: For group paging TPUI class D is defined.

5.2.59 Selection of additional character sets

This feature shall be implemented by the minimum set of public access protocol elements plus the FT shall be able to send <<alphanumeric>> information element as specified in ETS 300 175-5 [5] and the PT shall be able to understand and react upon this information element.

5.2.60 Data capability

The most basic data service can be provided using voice band modems over the standard speech channel (i.e. via the ADPCM codec). Data rates up to 4,8 kbit/s are possible. This feature is fully supported by the minimum set of public access protocol elements.

Profiles for more powerful data services will be subject to future standardisation.

5.2.61 Keypad protocol for supplementary services

The CRSS keypad protocol for supplementary services (feature 61a) is fully supported by the minimum set of public access protocol elements.

The CISS keypad protocol for supplementary services (feature 61b) shall be implemented by the minimum set of public access protocol elements plus the following:

The FT and PT shall support the CISS keypad protocol as specified in ETS 300 175-5 [5].

5.2.62 Feature key management protocol for supplementary services

This feature shall be implemented by the minimum set of public access protocol elements plus the FT and PT shall support the CRSS feature key management protocol (feature 62a) or the CISS feature key management protocol (feature 62b) as specified in ETS 300 175-5 [5].

5.2.63 Functional protocol for supplementary services

This feature shall be implemented by the minimum set of public access protocol elements plus the FT and PT shall support the CRSS functional protocol (feature 63a) or the CISS functional protocol (feature 63b) as specified in ETS 300 175-5 [5]. Any supplementary service may be implemented independently of any other.

5.2.64 Dial tone detection indication

This feature shall be implemented by the minimum set of public access protocol elements plus the FT shall be able to send the <<signal>> information element with the coding "dial tone on" as specified in ETS 300 175-5 [5] and the PT shall be able to understand this information element.

5.2.65 Request for indication of (temporary) subscriber number

This feature shall be implemented by the minimum set of public access protocol elements plus the FT and PT shall support the CRSS feature key management protocol (feature 65a) or the CISS feature key management protocol (feature 65b) as specified in ETS 300 175-5 [5]. The PT and FT shall support the feature coding "indication of subscriber number".

5.2.66 Portable part capability/FP capability data exchange

This feature is fully supported by the minimum set of public access protocol elements.

5.2.67 Subscription registration user procedure (on-air)

This feature is a local implementation and does not effect the DECT layers.

NOTE: For on-air subscription data exchange see the feature subscription data exchange.

5.2.68 Subscription registration user procedure (keypad)

This feature is a local implementation and does not effect the DECT layers.

5.2.69 Subscription registration user procedure (DECT authentication module)

This feature is a local implementation and does not effect the DECT layers.

5.2.70 Subscription data exchange (on-air)

This feature is fully supported by the minimum set of public access protocol elements.

NOTE: The necessary elements of procedure for this feature number 70 are indicated in clause 6.

5.2.71 Multicell FP coverage

This feature is a local implementation and does not effect the DECT layers.

5.2.72 Handover

This feature is fully supported by the minimum set of public access protocol elements.

The FT shall provide intracell handover by supporting bearer handover (feature 72b) or connection handover (feature 72c).

The FT may provide intercell handover in which case the FT shall support bearer handover (feature 72b) or connection handover (feature 72c) or external handover (feature 72e).

The PT shall support bearer handover (feature 72b) and connection handover (feature 72c) and may optionally support external handover (feature 72e).

These requirements are summarised in table 4.

Table 4

		FT	PT
Intracell	Bearer handover	(note)	M
	Connection handover	(note)	M
Intercell	Bearer handover	0	M
	Connection handover	0	M
	External handover	0	0

NOTE : The FP shall provide either bearer handover or connection handover for the intracell case.

M: mandatory;

O: optional.

5.2.73 Multiple subscription registration

This feature is fully supported by the minimum set of public access protocol elements, see also ETS 300 175-6 [6].

This feature affects the local implementation in the terminal.

5.2.74 All-physical-channel capability

This feature is fully supported by the minimum set of public access protocol elements.

This feature affects the local implementation in the terminal.

6 Requirements regarding the NWK layer

Refer to ETS 300 175-5 [5].

The minimum service shall only require the provision of a single instance of CC (one independent call) together with support of two MM procedures as detailed in ETS 300 175-5 [5].

The minimum public access service shall not require the use of extended transaction identifiers (refer to ETS 300 175-5 [5], subclause 7.3). Extended transaction identifiers should not be used (even by equipment that supports their use).

NOTE: Extended transaction identifiers may nonetheless be supported. If they are supported, the use of an extended transaction identifier by the peer entity should not of itself constitute an error.

6.1 Required procedures

6.1.1 CC procedures

The complete state machine of CC as defined in ETS 300 175-5 [5] shall be implemented in both the PT and FT. The following procedures listed below which are indicated as mandatory shall be provided for the minimum public access service.

Table 5

CC procedure	FT	PT	Feature number
PT initiated call establishment	M	M	0
FT initiated call establishment	0	0	16
Call information procedures	M	M	0
Call release procedures	M	M	0,16

M: mandatory;
O: optional.

6.1.2 MM procedures

Those MM procedures listed below which are indicated as mandatory shall be provided for the minimum public access service. The "feature number" indicates for which feature of clause 5 the procedure is necessary.

Table 6

MM procedure	FT	PT	Feature number
Identification of PT	0	M	23,24,25
Temporary identity assignment	0	M	25
Authentication of PT	M	M	20,24,25,30
Authentication of user	0	M	21,24,25,30,57
Authentication of FT	M	0	22
Location registration	0	0	16,41
Detach	0	0	16,42
Location update	0	0	16,41
Obtaining access rights	M	M	25,70
Terminating access rights	0	M	31,31p
Key allocation	M	M	70
Parameter retrieval	0	0	72e
Ciphering	0	0	33,34

M: mandatory;
O: optional.

NOTE: Provision of "authentication of FT" is mandatory in the FT, because provision of on-air subscription data exchange (feature 70) is mandatory.

6.1.3 COMS procedures

No COMS procedures are required for the minimum public access service.

For alphanumeric messaging (feature 32) COMS procedures are required for case C only. This shall provide messages based on the <<alphanumeric>> information element. Provision of this feature requires equipment to be capable of sending or receiving messages containing 3 complete message segments.

6.1.4 CLMS procedures

No CLMS procedures are required for the minimum public access service.

For alphanumeric messaging (feature 32) CLMS procedures are required for cases A and B only. This shall provide messages based on the <<alphanumeric>> information element. Provision of this feature requires equipment to be capable of sending or receiving messages containing 3 complete message segments.

6.1.5 LCE procedures

"Direct PT initiated link establishment" and "link release" shall be provided. For partial release (feature 6) the delayed release shall be implemented (timer <LCE.02>).

For incoming calls (feature 16) the "indirect (paged) FT initiated link establishment" shall also be provided.

For alphanumeric messaging (feature 32) in case B the connectionless link procedures shall also be provided.

6.1.6 Supplementary service procedures

Those supplementary service procedures listed below which are indicated as mandatory shall be provided for the minimum public access service. The "feature number" indicates for which feature of clause 5 the procedure is necessary.

Table 7

Supplementary service procedure	FT & PT	Feature number
Keypad protocol	M	12, 13, 14, 61
Feature key management protocol	O	11, 15, 38, 39, 40, 43, 44, 62, 65
Functional protocol	O	63
Hold procedures	O	17
Retrieve procedures	O	18, 19

M: mandatory;
 O: optional.

6.1.7 Management procedures

The Test Management (TM) procedures shall be provided for minimum public access service. The Upper Tester (UT) procedure shall be implemented in the case where the MM procedures can not be invoked by other means at the test house (as declared by the manufacturer).

For supported MM procedures, management of MM procedures shall be implemented.

For voice and user data traffic encryption activation/deactivation (feature 33) and signalling traffic encryption activation/deactivation (feature 34); call ciphering management procedures shall be provided.

For intercell external handover (feature 72e), the external handover management procedure shall be provided.

6.2 Required messages in the PT and FT

The following tables show which messages the PT and FT shall be able to send/receive for minimum public access service; marked with mandatory.

The tables also show the features requiring the implementation of specific optional messages; marked with optional and feature number. All other features may be implemented using the optional information elements in the mandatory set of messages.

M: mandatory;
 O: optional;
 -: not applicable.

Table 8: PT Send

CC Messages	send	Feature number
{CC-ALERTING}	O	16
{CC-CALL-PROC}	-	-
{CC-CONNECT}	O	16
{CC-CONNECT-ACK}	-	-
{CC-INFO}	M	-
{CC-NOTIFY}	-	-
{CC-RELEASE}	M	-
{CC-RELEASE-COM}	M	-
{CC-SETUP}	M	-
{CC-SETUP-ACK}	-	-
{HOLD}	O	17
{HOLD-ACK}	O	17
{HOLD-REJECT}	O	17
{RETRIEVE}	O	18,19
{RETRIEVE-ACK}	O	18,19
{RETRIEVE-REJECT}	O	18,19
CISS Messages		
{CISS-REGISTER}	O	15b, 38b, 39b, 40b, 65b
{FACILITY}	O	15b, 38b, 39b, 40b, 65b
{CISS-RELEASE-COM}	O	15b, 38b, 39b, 40b, 65b
MM Messages		
{ACCESS-RIGHTS-ACCEPT}	-	-
{ACCESS-RIGHTS-REJECT}	-	-
{ACCESS-RIGHTS-REQUEST}	M	-
{ACCESS-RIGHTS-TERMINATE-ACCEPT}	M	-
{ACCESS-RIGHTS-TERMINATE-REJECT}	M	-
{ACCESS-RIGHTS-TERMINATE-REQUEST}	O	31p
{AUTHENTICATION-REJECT}	M	-
{AUTHENTICATION-REPLY}	M	-
{AUTHENTICATION-REQUEST}	M	-
{CIPHER-REJECT}	O	33, 34
{CIPHER-REQUEST}	-	-
{CIPHER-SUGGEST}	O	33, 34
{DETACH}	O	16, 42
{IDENTITY-REQUEST}	-	-
{IDENTITY-REPLY}	M	-
{KEY-ALLOCATE}	-	-
{LOCATE-ACCEPT}	-	-
{LOCATE-REJECT}	-	-
{LOCATE-REQUEST}	O	16, 41
{MM-INFO-ACCEPT}	-	-
{MM-INFO-REJECT}	-	-
{MM-INFO-REQUEST}	O	72e
{MM-INFO-SUGGEST}	-	-
{TEMPORARY-IDENTITY-ASSIGN}	-	-
{TEMPORARY-IDENTITY-ASSIGN-REJ}	M	-
{TEMPORARY-IDENTITY-ASSIGN-ACK}	M	-
CLMS Messages		
{CLMS-FIXED}	-	-
{CLMS-VARIABLE}	O	32; case B
COMS Messages		
{COMS-SETUP}	O	32; case C
{COMS-CONNECT}	O	32; case C
{COMS-INFO}	O	32; case C
{COMS-ACK}	O	32; case C
{COMS-RELEASE}	O	32; case C
{COMS-RELEASE-COM}	O	32; case C
LCE Messages		
{LCE-PAGE-RESPONSE}	M	16
{LCE-PAGE-REJECT}	-	-
{LCE-REQUEST-PAGE}	-	-

Table 9: PT Receive

CC Messages	receive	Feature number
{CC-ALERTING}	M	
{CC-CALL-PROC}	M	
{CC-CONNECT}	M	
{CC-CONNECT-ACK}	O	16
{CC-INFO}	M	
{CC-NOTIFY}	M	
{CC-RELEASE}	M	
{CC-RELEASE-COM}	M	
{CC-SETUP}	O	16
{CC-SETUP-ACK}	M	
{HOLD}	O	17
{HOLD-ACK}	O	17
{HOLD-REJECT}	O	17
{RETRIEVE}	O	18,19
{RETRIEVE-ACK}	O	18,19
{RETRIEVE-REJECT}	O	18,19
CISS Messages		
{CISS-REGISTER}	O	15b, 38b, 39b, 40b, 65b
{FACILITY}	O	15b, 38b, 39b, 40b, 65b
{CISS-RELEASE-COM}	O	15b, 38b, 39b, 40b, 65b
MM Messages		
{ACCESS-RIGHTS-ACCEPT}	M	
{ACCESS-RIGHTS-REJECT}	M	
{ACCESS-RIGHTS-REQUEST}	-	-
{ACCESS-RIGHTS-TERMINATE-ACCEPT}	O	31p
{ACCESS-RIGHTS-TERMINATE-REJECT}	O	31p
{ACCESS-RIGHTS-TERMINATE-REQUEST}	M	
{AUTHENTICATION-REJECT}	M	
{AUTHENTICATION-REPLY}	M	
{AUTHENTICATION-REQUEST}	M	
{CIPHER-REJECT}	O	33, 34
{CIPHER-REQUEST}	O	33, 34
{CIPHER-SUGGEST}	-	-
{DETACH}	-	-
{IDENTITY-REQUEST}	M	
{IDENTITY-REPLY}	-	-
{KEY-ALLOCATE}	M	
{LOCATE-ACCEPT}	O	16, 41
{LOCATE-REJECT}	O	16, 41
{LOCATE-REQUEST}	-	-
{MM-INFO-ACCEPT}	O	72e
{MM-INFO-REJECT}	O	72e
{MM-INFO-REQUEST}	-	-
{MM-INFO-SUGGEST}	O	16, 41
{TEMPORARY-IDENTITY-ASSIGN}	M	
{TEMPORARY-IDENTITY-ASSIGN-REJ}	-	-
{TEMPORARY-IDENTITY-ASSIGN-ACK}	-	-
CLMS Messages		
{CLMS-FIXED}	O	32; CASE A
{CLMS-VARIABLE}	O	32; case B
COMS Messages		
{COMS-SETUP}	O	32; CASE C
{COMS-CONNECT}	O	32; CASE C
{COMS-INFO}	O	32; CASE C
{COMS-ACK}	O	32; CASE C
{COMS-RELEASE}	O	32; CASE C
{COMS-RELEASE-COM}	O	32; case C
LCE Messages		
{LCE-PAGE-RESPONSE}	-	-
{LCE-PAGE-REJECT}	M	16
{LCE-REQUEST-PAGE}	M	16

Table 10: FT Send

CC Messages	send	Feature number
{CC-ALERTING}	O	
{CC-CALL-PROC}	O	
{CC-CONNECT}	M	
{CC-CONNECT-ACK}	O	16
{CC-INFO}	M	
{CC-NOTIFY}	M	
{CC-RELEASE}	M	
{CC-RELEASE-COM}	M	
{CC-SETUP}	O	16
{CC-SETUP-ACK}	O	
{HOLD}	O	17
{HOLD-ACK}	O	17
{HOLD-REJECT}	O	17
{RETRIEVE}	O	18,19
{RETRIEVE-ACK}	O	18,19
{RETRIEVE-REJECT}	O	18,19
CISS Messages		
{CISS-REGISTER}	O	15b, 38b, 39b, 40b, 65b
{FACILITY}	O	15b, 38b, 39b, 40b, 65b
{CISS-RELEASE-COM}	O	15b, 38b, 39b, 40b, 65b
MM Messages		
{ACCESS-RIGHTS-ACCEPT}	M	
{ACCESS-RIGHTS-REJECT}	M	
{ACCESS-RIGHTS-REQUEST}	-	-
{ACCESS-RIGHTS-TERMINATE-ACCEPT}	O	31p
{ACCESS-RIGHTS-TERMINATE-REJECT}	O	31p
{ACCESS-RIGHTS-TERMINATE-REQUEST}	O	31
{AUTHENTICATION-REJECT}	M	
{AUTHENTICATION-REPLY}	M	
{AUTHENTICATION-REQUEST}	M	
{CIPHER-REJECT}	O	33, 34
{CIPHER-REQUEST}	O	33, 34
{CIPHER-SUGGEST}	-	-
{DETACH}	-	-
{IDENTITY-REQUEST}	O	23, 24, 25
{IDENTITY-REPLY}	-	-
{KEY-ALLOCATE}	M	
{LOCATE-ACCEPT}	O	16, 41
{LOCATE-REJECT}	O	16, 41
{LOCATE-REQUEST}	-	-
{MM-INFO-ACCEPT}	O	72e
{MM-INFO-REJECT}	O	72e
{MM-INFO-REQUEST}	-	-
{MM-INFO-SUGGEST}	O	16, 41
{TEMPORARY-IDENTITY-ASSIGN}	O	25
{TEMPORARY-IDENTITY-ASSIGN-REJ}	-	-
{TEMPORARY-IDENTITY-ASSIGN-ACK}	-	-
CLMS Messages		
{CLMS-FIXED}	O	32; CASE A
{CLMS-VARIABLE}	O	32; case B
COMS Messages		
{COMS-SETUP}	O	32; CASE C
{COMS-CONNECT}	O	32; CASE C
{COMS-INFO}	O	32; CASE C
{COMS-ACK}	O	32; CASE C
{COMS-RELEASE}	O	32; CASE C
{COMS-RELEASE COM}	O	32; case C
LCE Messages		
{LCE-PAGE-RESPONSE}	-	-
{LCE-PAGE-REJECT}	O	16
{LCE-REQUEST-PAGE}	O	16

Table 11: FT Receive

CC Messages	receive	Feature number
{CC-ALERTING}	O	16
{CC-CALL-PROC}	-	-
{CC-CONNECT}	O	16
{CC-CONNECT-ACK}	-	-
{CC-INFO}	M	-
{CC-NOTIFY}	-	-
{CC-RELEASE}	M	-
{CC-RELEASE-COM}	M	-
{CC-SETUP}	M	-
{CC-SETUP-ACK}	-	-
{HOLD}	O	17
{HOLD-ACK}	O	17
{HOLD-REJECT}	O	17
{RETRIEVE}	O	18, 19
{RETRIEVE-ACK}	O	18, 19
{RETRIEVE-REJECT}	O	18, 19
CISS Messages		
{CISS-REGISTER}	O	15b, 38b, 39b, 40b, 65b
{FACILITY}	O	15b, 38b, 39b, 40b, 65b
{CISS-RELEASE-COMplete}	O	15b, 38b, 39b, 40b, 65b
MM Messages		
{ACCESS-RIGHTS-ACCEPT}	-	-
{ACCESS-RIGHTS-REJECT}	-	-
{ACCESS-RIGHTS-REQUEST}	M	-
{ACCESS-RIGHTS-TERMINATE-ACCEPT}	O	31
{ACCESS-RIGHTS-TERMINATE-REJECT}	O	31
{ACCESS-RIGHTS-TERMINATE-REQUEST}	O	31p
{AUTHENTICATION-REJECT}	M	-
{AUTHENTICATION-REPLY}	M	-
{AUTHENTICATION-REQUEST}	M	-
{CIPHER-REJECT}	O	33, 34
{CIPHER-REQUEST}	-	-
{CIPHER-SUGGEST}	O	33, 34
{DETACH}	O	16, 42
{IDENTITY-REQUEST}	-	-
{IDENTITY-REPLY}	O	23, 24, 25
{KEY-ALLOCATE}	-	-
{LOCATE-ACCEPT}	-	-
{LOCATE-REJECT}	-	-
{LOCATE-REQUEST}	O	16, 41
{MM-INFO-ACCEPT}	-	-
{MM-INFO-REJECT}	-	-
{MM-INFO-REQUEST}	O	72e
{MM-INFO-SUGGEST}	-	-
{TEMPORARY-IDENTITY-ASSIGN}	-	-
{TEMPORARY-IDENTITY-ASSIGN-REJ}	O	25
{TEMPORARY-IDENTITY-ASSIGN-ACK}	O	25
CLMS Messages		
{CLMS-FIXED}	-	-
{CLMS-VARIABLE}	O	32; case B
COMS Messages		
{COMS-SETUP}	O	32; CASE C
{COMS-CONNECT}	O	32; CASE C
{COMS-INFO}	O	32; CASE C
{COMS-ACK}	O	32; CASE C
{COMS-RELEASE}	O	32; CASE C
{COMS-RELEASE-COM}	O	32; case C
LCE Messages		
{LCE-PAGE-RESPONSE}	O	16
{LCE-PAGE-REJECT}	-	-
{LCE-REQUEST-PAGE}	-	-

6.3 Required mandatory information elements

The minimum required information elements are as specified for each message in ETS 300 175-5 [5]. Note that repeated information elements are only allowed where explicitly indicated by a repeat indicator element in this section.

6.3.1 Information elements in CC messages

This subclause defines the contents of messages that are mandatory or are optional for the minimum service or are required for a specific feature:

PTX means: the PT must transmit;
 PRX means: the PT must be able to receive/manage;
 FTX means: the FT must transmit;
 FRX means: the FT must be able to receive/manage.

M: mandatory;
 I: required for the implementation of feature 16 (incoming calls) only;
 N: not allowed;
 O: optional;
 -: not applicable;
 (x): note x.

To simplify these tables, some information elements relating to the provision of data services have been omitted. Any missing elements shall be understood to be "not applicable".

{CC-SETUP}	PTX	FRX	FTX	PRX
Portable Identity	M	M	I	I
Fixed Identity	M	M	I	I
Basic Service (NOTE 10)	M	M	I	I
IWU attributes	(11)	(11)	I (11)	I (11)
Call attributes	(11)	(11)	I (11)	I (11)
Connection attributes	(4)	(4)	I (4)	I (4)
Cipher Info	O	O	O	O
Connection identity	(4)	(4)	I (4)	I (4)
Facility	O	O	O	O
Progress indicator	N	N	O	O
Display	N	N	O	O
Keypad	O	O	N	N
Signal	N	N	I (12)	I (12)
Feature Activate	O	O	N	N
Feature Indicate	N	N	O	O
Network parameter	(13)	(13)	N	N
Terminal capability	(7)	M	N	N
Calling party number	O	O	O	O
Called party number	(1)	M	O	O
Called party subaddress	O	O	O	O
Sending complete	O	O	O	O
IWU-TO-IWU	O	O	O	O
IWU-PACKET	O	O	O	O

{CC-SETUP-ACK}	PTX	FRX	FTX	PRX
Info Type	-	-	(13)	(13)
Portable Identity	-	-	O	M
Fixed Identity	-	-	O	M
Location area	-	-	(13)	(13)
Call attributes	-	-	-	-
Connection Identity	-	-	(4)	(4)
Facility	-	-	O	O
Progress Indicator	-	-	(5, 8)	(8)
Display	-	-	O	O
Signal	-	-	(9)	O
Feature indicate	-	-	(6)	O
Delimiter request	-	-	O	O
IWU-TO-IWU	-	-	O	O
IWU-PACKET	-	-	O	O

{CC-INFO} during establishment	PTX	FRX	FTX	PRX
Location area	(13)	(13)	N	N
NWK assigned identity	(13)	(13)	N	N
Facility	O	O	N	N
Progress indicator	N	N	O	O
Display	N	N	O	O
Keypad	(3)	M	N	N
Signal	N	N	I (12)	I (12)
Feature activate	O	O	N	N
Feature indicate	N	N	O	O
Network parameter	(13)	(13)	N	N
Called party number	(2)	M	N	N
Called party subaddress	O	O	N	N
Sending complete	O	O	N	N
Test hook control	N	N	N	M(16)
IWU-TO-IWU	O	O	O	O
IWU-PACKET	O	O	O	O

{CC-RELEASE}	PTX	FRX	FTX	PRX
Release Reason	(14)	(14)	O	O
Facility	N	N	O	O
Display	N	N	O	O
Feature indicate	N	N	(6)	O
IWU-TO-IWU	O	O	O	O
IWU-PACKET	O	O	O	O

{CC-RELEASE-COM}	PTX	FRX	FTX	PRX
Release Reason	(17)	O	(17)	O
Identity type	-	-	(13)	(13)
Location area	-	-	(13)	(13)
IWU attributes	-	-	-	-
Facility	N	N	O	O
Display	N	N	O	O
Feature indicate	N	N	(6)	O
Network parameter	-	-	(13)	(13)
IWU-TO-IWU	O	O	O	O
IWU-PACKET	O	O	O	O

{CC-CALL-PROC}	PTX	FRX	FTX	PRX
Call attributes	-	-	-	-
Connection Identity	-	-	(4)	(4)
Facility	-	-	O	O
Progress Indicator	-	-	(5, 8)	(8)
Display	-	-	O	O
Signal	-	-	(9)	O
Feature indicate	-	-	(6)	O
IWU-TO-IWU	-	-	O	O
IWU-PACKET	-	-	O	O

{CC-ALERTING}	PTX	FRX	FTX	PRX
Call attributes	-	-	-	-
Connection Identity	I (4)	I (4)	(4)	(4)
Facility	N	N	O	O
Progress indicator	N	N	(5, 8)	(8)
Display	N	N	O	O
Signal	N	N	(9)	O
Feature indicate	N	N	(6)	O
Terminal capability	I (15)	I (15)	-	-
IWU-TO-IWU	O	O	O	O
IWU-PACKET	O	O	O	O

{CC-CONNECT}	PTX	FRX	FTX	PRX
Call attributes	-	-	-	-
Connection Identity	I (4)	I (4)	(4)	(4)
Facility	O	O	O	O
Progress Indicator	N	N	(5)	O
Display	N	N	O	O
Signal	N	N	(9)	O
Feature indicate	N	N	(6)	O
Terminal capability	I (15)	I (15)	-	-
IWU-TO-IWU	O	O	O	O
IWU-PACKET	O	O	O	O

{CC-CONNECT-ACK}	PTX	FRX	FTX	PRX
Display	-	-	O	O
Feature indicate	-	-	(6)	O
IWU-TO-IWU	-	-	O	O
IWU-PACKET	-	-	O	O

{CC-INFO} during connection	PTX PTX	FRX FRX	FTX FTX	PRX PRX
Location area	N	N	N	N
NWK assigned identity	N	N	N	N
Facility	O	O	O	O
Progress indicator	N	N	O	O
Display	N	N	O	O
Keypad	M	M	N	N
Signal	N	N	(9)	O
Feature activate	O	O	N	N
Feature indicate	N	N	(6)	O
Network parameter	N	N	N	N
Called party number	N	N	N	N
Called party subaddress	N	N	N	N
Sending complete	O	O	O	O
Test hook control	N	N	N	M(16)
IWU-TO-IWU	O	O	O	O
IWU-PACKET	O	O	O	O

{CC-NOTIFY}	PTX	FRX	FTX	PRX
Timer restart	-	-	O	M

{HOLD}	PTX	FRX	FTX	PRX
Display	N	N	O	O

{HOLD-ACK}	PTX	FRX	FTX	PRX
Display	N	N	O	O

{HOLD-REJECT}	PTX	FRX	FTX	PRX
Display	N	N	O	O
Reject Reason	O	O	O	O

{RETRIEVE}	PTX	FRX	FTX	PRX
Display	N	N	O	O

{RETRIEVE-ACK}	PTX	FRX	FTX	PRX
Display	N	N	O	O

{RETRIEVE-REJECT}	PTX	FRX	FTX	PRX
Display	N	N	O	O
Reject Reason	O	O	O	O

- NOTE 1: En-block sending case into the {CC-SETUP} message. The PP should use the coding defined in subclause 6.4.2, and the FP may assume this value in all cases.
- NOTE 2: En-block sending case into a {CC-INFO} message. The PP should use the coding defined in subclause 6.4.2, and the FP may assume this value in all cases.
- NOTE 3: Keypad is optional method of dialling during CC call establishment. Keypad is mandatory in the active state for support of non-DECT specific supplementary services.
- NOTE 4: The connection attributes and connection identity elements may be used to indicate an advanced connection, but their use is not recommended. acceptance by the peer is not certain: only basic connections are mandated and these elements shall not be used for basic connections.
- NOTE 5: Progress indicator shall be sent by FP if a corresponding (out-of-band) signal is received from the local network. Understanding of codes by PP is optional except as given in note 8.
- NOTE 6: Feature indicate is mandatory only in response to a previous received and understood "feature activate".
- NOTE 7: Terminal capability may optionally be included in the {CC-SETUP} message for outgoing calls. If absent, the default codings given in subclause 6.4.1, shall be assumed by the FP.
- NOTE 8: Progress indicator may be used at any time to carry cause 8 (In band information or appropriate pattern now available). PPs shall understand this coding and shall connect their U-plane.
- NOTE 9: Signal shall be sent by FP if a corresponding (out-of-band) signal is received from the local network. Understanding of codes by PP is optional, except as given in note 12.
- NOTE 10: The basic service element shall use the codings defined in subclause 6.4.1.
- NOTE 11: The call attributes and IWU attributes elements are mandatory if the basic service element indicates the value "other". They shall only be used if the service is not basic as given by the default codings given in annex E of ETS 300 175-5 [5] (reproduced here as annex B).
- NOTE 12: (*Incoming calls option*) Signal may be sent at any time to initiate alerting at PP. FP shall only use one of the codings given in subclause 6.4.2. PP shall alert user in response to any alerting pattern.
- NOTE 13: These elements apply to external handover.
- NOTE 14: For partial release the FP shall understand the release reason value "partial release". Transmission of this value by the PP is optional.
- NOTE 15: The use of the Terminal Capabilities (TC) for incoming calls is optional. If used it shall be sent in the first response message. If not used, the default values given in subclause 6.4.1, shall be assumed.
- NOTE 16: The test hook control information element shall only be supported during test standby mode.
- NOTE 17: Release reason shall be used and indicate "timer expiry" upon expiry of <CC.03>.

6.3.2 Information elements in CISS messages

This subclause defines the contents of messages that are mandatory or are optional for the minimum service or are required for a specific feature:

PTX means: the PT must transmit;
 PRX means: the PT must be able to receive/manage;
 FTX means: the FT must transmit;
 FRX means: the FT must be able to receive/manage.

M: mandatory;
 N: not allowed;
 O: optional;
 -: not applicable;
 (x): note x.

{CISS-REGISTER}	PTX	FRX	FTX	PRX
Facility	O	O	O	O
Display	N	N	O	O
Keypad	O	O	N	N
Feature Activate	O	O	N	N
Feature Indicate	N	N	O	O

{FACILITY}	PTX	FRX	FTX	PRX
Facility	O	O	O	O
Display	N	N	O	O
Keypad	O	O	N	N
Feature Activate	O	O	N	N
Feature Indicate	N	N	O	O

{CISS-RELEASE-COM}	PTX	FRX	FTX	PRX
Release Reason	O	O	O	O
Facility	O	O	O	O
Display	N	N	O	O
Keypad	O	O	N	N
Feature Activate	O	O	N	N
Feature Indicate	N	N	O	O

6.3.3 Information elements in MM messages

Only MM messages which can contain at least one information element are listed below. This subclause defines the contents of messages that are mandatory or are optional for the minimum service or are required for a specific feature. The provision of the messages is indicated in subclauses 6.2 and 6.3 and cannot be seen from this subclause. If however a specific MM message is used, then the required information elements are listed in the following tables:

PTX means: the PT shall transmit;
PRX means: the PT shall be able to receive/manage;
FTX means: the FT shall transmit;
FRX means: the FT shall be able to receive/manage.

M: mandatory;
O: optional;
N: not allowed;
-: not applicable;
(x): note x.

{ACCESS-RIGHTS-ACCEPT}	PTX	FRX	FTX	PRX
Portable identity	-	-	M	M
Fixed identity	-	-	M	M
Location area	-	-	O	O
AUTH TYPE	-	-	O	O
Cipher info	-	-	O	O
ZAP field	-	-	O	M
Service class	-	-	O	M
IWU-TO-IWU	-	-	O	O

{ACCESS-RIGHTS-REJECT}	PTX	FRX	FTX	PRX
Reject reason	-	-	O	O
Duration	-	-	O	O

{ACCESS-RIGHTS-REQUEST}	PTX	FRX	FTX	PRX
Portable identity	M	M	-	-
AUTH TYPE	O	O	-	-
Cipher info	O	O	-	-
Terminal capability	O	O	-	-
IWU-to-IWU	O	O	-	-

{ACCESS-RIGHTS-TERMINATE-REJECT}	PTX	FRX	FTX	PRX
Reject reason	O	O	O	O
Duration	N	N	O	O

{ACCESS-RIGHTS-TERM-REQUEST}	PTX	FRX	FTX	PRX
Portable identity	M	M	M	M
Fixed identity	O	M	O	M
IWU-to-IWU	O	O	O	O

{AUTHENTICATION-REJECT}	PTX	FRX	FTX	PRX
AUTH-TYPE	O	O	O	O
Reject reason	O	O	O	O

{AUTHENTICATION-REPLY}	PTX	FRX	FTX	PRX
RES	M	M	M	M
RS	N	N	(1)	(1)
ZAP field	(2)	O	N	N
Service class	(2)	O	N	N
Key	(3)	O	N	N
IWU-to-IWU	O	O	O	O

- NOTE 1: If a DECT standard authentication algorithm is used, then the <<RS>> information element is mandatory.
- NOTE 2: If the information element had been received and stored earlier, then it is mandatory to include it.
- NOTE 3: If the TXC bit in the <<auth-type>> information element in the corresponding {AUTHENTICATION-REQUEST} message had been set, then it is mandatory to include the <<key>> information element.

{AUTHENTICATION-REQUEST}	PTX	FRX	FTX	PRX
AUTH-TYPE	M	M	M	M
RAND	M	M	M	M
RES	(2)	(2)	N	N
RS	N	N	(1)	(1)
Cipher info	O	O	O	O
IWU-to-IWU	O	O	O	O

- NOTE 4: If a DECT standard authentication algorithm is used, then the <<RS>> information element is mandatory.
- NOTE 5: If the {AUTHENTICATION-REQUEST} is used inside the key allocation procedure, then the <<RES>> information element is mandatory.

{CIPHER-REJECT}	PTX	FRX	FTX	PRX
Cipher info	O	O	O	O
Reject reason	O	O	O	O

{CIPHER-REQUEST}	PTX	FRX	FTX	PRX
Cipher info	-	-	M	M
Call identity	-	-	O	O
Connection identity	-	-	O	O
IWU-to-IWU	-	-	O	O

{CIPHER-SUGGEST}	PTX	FRX	FTX	PRX
Cipher info	M	M	-	-
Call identity	O	O	-	-
Connection identity	O	O	-	-
IWU-to-IWU	O	O	-	-

{DETACH}	PTX	FRX	FTX	PRX
Portable identity	M	M	-	-
NWK assigned identity	(1)	O	-	-
IWU-to-IWU	O	O	-	-

- NOTE 6: If the network assigned identity had been received and stored earlier, then it is mandatory to include it.

{IDENTITY-REPLY}	PTX	FRX	FTX	PRX
Repeat indicator	0	0	-	-
Portable identity	(1)	0	-	-
Repeat indicator	0	0	-	-
Fixed identity	(1)	0	-	-
Repeat indicator	0	0	-	-
NWK assigned identity	(1)	0	-	-
IWU-to-IWU	0	0	-	-

NOTE 7: The included information elements depend on the identity-request.

{IDENTITY-REQUEST}	PTX	FRX	FTX	PRX
Identity type	-	-	M	M
IWU-to-IWU	-	-	0	0

{KEY-ALLOCATE}	PTX	FRX	FTX	PRX
Allocation Type	-	-	M	M
RAND	-	-	M	M
RS	-	-	M	M

{LOCATE-ACCEPT}	PTX	FRX	FTX	PRX
Portable identity	-	-	0	M
Location area	-	-	M	M
NWK assigned identity	-	-	0	M
Duration	-	-	0	M
IWU-to-IWU	-	-	0	0

{LOCATE-REJECT}	PTX	FRX	FTX	PRX
Reject reason	-	-	0	0
Duration	-	-	0	0

{LOCATE-REQUEST}	PTX	FRX	FTX	PRX
Portable identity	M	M	-	-
Fixed identity	(2)	0	-	-
Location area	(2)	0	-	-
NWK assigned identity	(1)	0	-	-
Cipher info	0	0	-	-
Set-up capabilities	0	0	-	-
Terminal capability	0	0	-	-
IWU-to-IWU	0	0	-	-

NOTE 8: If the network assigned identity had been received and stored earlier, then it is mandatory to include it.

NOTE 9: If the location area has changed, then it is mandatory to include the <<fixed identity>> and <<location area>> information elements identifying the previous location area.

{MM-INFO-ACCEPT}	PTX	FRX	FTX	PRX
Info type	-	-	0	0
Fixed identity	-	-	0	0
Location area	-	-	0	0
NWK assigned identity	-	-	0	0
Network parameter	-	-	0	0
Duration	-	-	0	0
IWU-to-IWU	-	-	0	0

{MM-INFO-REJECT}	PTX	FRX	FTX	PRX
Reject reason	-	-	0	0

{MM-INFO-REQUEST}	PTX	FRX	FTX	PRX
Info type	M	M	-	-
Portable identity	O	O	-	-
Fixed identity	O	O	-	-
Location area	O	O	-	-
NWK assigned identity	O	O	-	-
Network parameter	O	O	-	-
IWU-to-IWU	O	O	-	-

{MM-INFO-SUGGEST}	PTX	FRX	FTX	PRX
Info type	-	-	M	M
Fixed identity	-	-	O	O
Location area	-	-	O	O
NWK assigned identity	-	-	O	O
Network parameter	-	-	O	O
IWU-to-IWU	-	-	O	O

{TEMPORARY-IDENTITY-ASSIGN}	PTX	FRX	FTX	PRX
Portable identity	-	-	(1)	M
NWK assigned identity	-	-	(1)	M
Duration	-	-	O	O
IWU-to-IWU	-	-	O	O

NOTE 10: At least one identity information element shall be included.

{TEMPORARY-IDENTITY-ASSIGN-REJECT}	PTX	FRX	FTX	PRX
Reject reason	O	O	-	-

6.4 Coding of information elements in CC messages

6.4.1 Coding of mandatory information elements in CC messages

These represent the common set of codings which shall always be supported by both the PT and FT. Other codings compatible with this specification shall be permissible subject to on-air negotiation.

Octet	Information element field	Field value
2	Call class	Normal OR Emergency
	Basic service	Default set-up atts

PAP coding for <<basic service>> information element

Octet	Information element field	Field value
3	Type	"ARI"
4	Length indicator	contains ARI length
≥ 5	ARC, ARD	contains ARI value

PAP coding for <<fixed identity>> information element

Octet	Information element field	Field value
3	Type	"IPUI"
4	Length of identity value	contains IPUI length
≥ 5	Identity value	contains IPUI value

PAP coding for <<portable identity>> information element

Octet	Information element field	Field value
3	Display capability	No display
	Tone capability	No tone capability
	Echo parameters	Minimum TCLw
	Ambient noise rejection	No
	Adaptive volume control	No
	Slot type	Full slot

Default PAP coding for <<terminal capability>> information element

NOTE: If the PT implements the default settings shown above, <<terminal capability>> is not required to be sent by the PT.

Keypad coding: both <<single-keypad>> and <<multi-keypad>> shall be supported. The minimum characters supported shall be:

0, 1, 2, 3, 4, 5, 6, 7, 8, 9, *, #

Display coding: both <<single-display>> and <<multi-display>> shall be supported if a display capability is declared in the <<terminal capability>> information element. The minimum characters supported shall be:

0, 1, 2, 3, 4, 5, 6, 7, 8, 9, *, #

Plus the control code "Clear display" (code value 0C hex).

6.4.2 Coding of optional information elements in CC messages

Octet	Information element field	Field value
3	Number Type	Unknown
	Number Plan	Unknown
4 - N	Called party number	DECT characters

PAP coding for <<called party number>> information element

Octet	Information element field	Field value
2	Signal value	Alerting on - cont Alerting off

Features 2 & 3: coding for <<signal>> information element

Octet	Information element field	Field value
2	Signal value	Alerting on - Patt 0

Feature 16: coding for <<signal>> information element

Octet	Information element field	Field Value
3	Symmetry	Symmetric connection
	Connection Identity	Unknown or NNN
4	Target number of bearers P>F (also defines minimum number)	1
5	Slot size	Full slot
	MAC service	IN minimum_delay
6	CF channel attributes	CF never
	MAC packet lifetime	Not applicable

PAP coding for <<connection attributes>> information element

Keypad coding: if an option is provided, it shall be supported in both <<single-keypad>> and <<multi-keypad>> information elements. Additional characters are required to support the following features:

- Feature 8: additional characters as defined in subclause 5.2.8;
- Feature 12: additional characters as defined in subclause 5.2.12;
- Feature 13: additional characters as defined in subclause 5.2.13;
- Feature 14: additional characters as defined in subclause 5.2.14.

6.5 Coding of information elements in MM messages

As specified in ETS 300 175-5 [5].

Auth-type coding: the DECT standard authentication algorithm 1 shall be supported.

Cipher information coding: for the feature ciphering (feature 33 and feature 34), the DECT standard cipher algorithm 1 shall be supported.

Location area: the PT shall be able to receive, store and send back "extended location information".

Network assigned identity: the PT shall be able to receive, store and send back a network assigned identity.

7 Requirements regarding the DLC layer

As specified in ETS 300 175-4 [4].

7.1 Control plane

7.1.1 Minimum requirements

The following types of operation shall be supported.

Class A acknowledged transfer operation over a connection oriented MAC service.

Frames shall be fragmented to use the C_S logical channel.

The PT shall support both the bearer handover procedure and the connection handover procedure.

The FT shall support the connection handover procedure as defined in subclause 5.2.72 for intracell handovers if bearer handover is not supported.

7.1.2 Incoming call (feature 16)

Short format and long format broadcast frames shall be supported.

7.1.3 Alphanumeric text messaging and radiopaging service (feature 32)

Case A: extended format broadcast frames shall be supported;

Case B: class U operation over a connectionless MAC service. The UI frames shall be fragmented to use the CL_F logical channel;

Case C: class U operation over a connection oriented MAC service. The UI frames shall be fragmented to use the C_S logical channel.

7.2 User plane

The LU1 transparent unprotected service shall be supported.

The FU1 frame structure shall be supported.

8 Mandatory requirements regarding the MAC layer

This clause refers to elements specified in ETS 300 175-3 [3]. Public access equipment shall provide at least all of the elements stated below.

8.1 MAC layer services

8.1.1 Connection oriented services

The FT and PT shall support basic connections, these are from service type 1f ($I_{N_minimum_delay}$). At least the B-field multiplex type U32a shall be supported.

8.1.2 Broadcast services

The FT shall support the continuous broadcast service.

8.2 MAC layer procedures

8.2.1 Connection oriented service procedures

8.2.1.1 General

The FT and PT shall support the basic connection set-up procedure and the A-field connection release procedure.

NOTE: The basic set-up procedure creates a basic connection.

The PT shall support the duplex bearer handover procedure and the connection handover procedure. If the FT does not support the connection handover procedure for intracell handover, the FT shall support the duplex bearer handover procedure.

NOTE: Support of the connection handover procedure requires the MAC to support additional messages as defined in subclause 8.4.2.4.

8.2.1.2 Antenna diversity in connection oriented services

8.2.1.2.1 Q1 setting in direction PT to FT

The PT shall set $Q1 = 1$ in the next associated transmission when the quality of the received burst is determined to be poor. The determination of the received quality may be based on the following:

- a) results of the A and X-CRCs;
- b) conditions of the S and Z fields;
- c) radio signal strength;
- d) other appropriate parameters.

The Q1 bit is defined in the A-field header message, refer to ETS 300 175-3 [3].

S- and Z-field failure are defined as in ETS 300 175-2 [2]. A-CRC and X-CRC are defined in ETS 300 175-3 [3].

8.2.1.2.2 Antenna change due to FT reception of Q1

If antenna diversity is implemented, the RFP shall, on reception of $Q1 = 1$, change antenna for next associated RFP transmission unless the RFP has knowledge of the optimum downlink transmission antenna obtained from simultaneous measurements of the last PT transmission as per subclause 8.3 of ETS 300 175-2 [2] on all provided antennas.

If $Q1 = 0$ is received by the RFP in the next associated slot, the antenna should also be changed for the associated receive direction.

8.2.1.2.3 Antenna change due to poor quality on slot received at FT

If antenna diversity is implemented, the RFP shall, when the quality of the received burst is poor, change antenna. The determination of the received quality may be based on the following:

- a) results of the A and X-CRCs;
- b) conditions of the S and Z fields;
- c) radio signal strength;
- d) other appropriate parameters.

S- and Z-field failure are defined as in ETS 300 175-2 [2]. A-CRC and X-CRC are defined in ETS 300 175-3 [3].

If the next associated slot is received error free by the RFP, the antenna should also be changed for the associated transmit direction.

8.2.1.3 Information for handover

8.2.1.3.1 Q1 and Q2 setting in direction FT to PT

Q1 and Q2 shall be used in accordance with ETS 300 175-3 [3]. The Q2 bit shall be set according to A-field and B-field acceptance. The minimum criteria for B-field rejection as defined in ETS 300 175-3 [3] is X-CRC field failure. It is also mandated to set Q1 on sliding collision information if $Q2 = 1$, and on A-CRC information if $Q2 = 0$. Sliding collision is defined in ETS 300 175-2 [2], annex B.

The Q1 bit and the Q2 bit are defined in the A-field header message, refer to ETS 300 175-3 [3].

8.2.1.3.2 PT reception of Q1 and Q2

The PT should use Q1 and Q2 information for making the handover decision.

8.2.2 Broadcast procedures

At least the following downlink broadcast procedures shall be supported by the FT:

- broadcast of N_T messages (see subclause 8.4.2.1);
- broadcast of mandatory Q_T messages (see subclause 8.4.2.2).

8.3 Scrambling

Scrambling of the B field as specified in ETS 300 175-3 [3] is mandatory.

8.4 Required messages

8.4.1 Header field

The FT and PT shall understand all tail identifications.

The FT and PT shall be able to send at least the following tail identifications codes:

Table 12

a0	a1	a2	Tail contents	Restrictions
0	0	0	C_T data packet number 0	
0	0	1	C_T data packet number 1	
0	1	1	identities information (N_T)	
1	0	0	multiframe synchronisation and system information (Q_T)	RFP only
1	1	0	MAC layer control (M_T)	
1	1	1	first CPP transmission (M_T)	PP only

"RFP only": means RFP transmissions only;

"PP only": means PP transmissions only.

The FT shall react correctly to the B field identification for "U type, I_N " and shall be able to send the B field identifications for "U type, I_N " and "no B-field".

The PT shall react correctly to the B field identifications for "U type, I_N " and "no B-field" and shall be able to send the B field identification for "U type, I_N ".

The FT and PT shall be able to send and shall react correctly to the Q1 and Q2 bits using the procedures defined in subclauses 8.2.1.2 and 8.2.1.3.

8.4.2 Messages in the tail field

8.4.2.1 Identities information (N_T tail)

PT and FT shall be able to send, and shall react correctly to the N_T tail.

8.4.2.2 System information and multiframe marker (Q_T tail)

The FT shall be able to send and the PT shall understand at least the following Q_T messages:

Table 13

QH	System Information	Man	Freq
000X	static system info	Yes	8
0010	extended RF carriers	note	8
0011	fixed part capabilities	Yes	8
0101	SARI list contents	No	8

where :

MAN: mandatory transmission (Yes/No);
FREQ: maximum repeat interval in multiframes, if implemented.

NOTE: Transmission of the "extended RF carriers" message is only mandated for FPs that support extended RF carrier operation.

8.4.2.3 Paging (P_T tail)

The transmission and understanding of paging messages is not required for the minimum public access profile.

8.4.2.4 MAC control (M_T tails)

PT and FT shall be able to send and shall react correctly to the following groups of messages:

- the basic connection control messages;
- MAC test messages.

The "unconfirmed_access_request" message shall not be used for a basic connection.

Equipment shall only respond to MAC test messages when operating in the "Test-Standby-Mode". Refer to I-ETS 300 176 [9].

8.4.3 Messages in the B-field

No operations that require transmission or response to B-field messages is required for the minimum public access profile.

Equipment shall understand the tail code associated with B-field messages as defined in subclause 8.4.1. Received B-field messages should be discarded if they cannot be understood.

8.5 Monitoring of speech quality

The X-CRC information from received slot with I_N data should be used to support monitoring of received speech quality.

9 MAC layer requirements for the optional features

This clause defines the MAC provisions required to support the optional functionality specified in clause 5.

9.1 Incoming call (feature 16)

The following additional facilities shall be provided:

The FT shall be able to send and the PT shall understand the following additional tail identification code:

Table 14

a0 a1 a2	Tail contents	Restrictions
1 1 1	paging tail (P_T)	RFP only

"RFP only": means RFP transmissions only.

The FT shall be able to send at least one of the following PT type tail messages:

- short page message;
- full page message.

The PT shall understand both of the above listed PT type tail messages.

The FT shall page PT in normal paging mode by using only full page messages or short page messages or both. Normal paging mode is defined in the RFP paging procedure of ETS 300 175-3 [3].

The low duty cycle idle_locked mode paging service is permitted.

The PT shall react correctly to both full page and short page messages. Detection and processing of paging messages is defined in the paging procedure of ETS 300 175-3 [3].

9.2 Alphanumeric text messaging and radiopaging service (feature 32)

9.2.1 Alphanumeric service via the MAC broadcast service (case A)

The FT shall be able to send and the PT shall understand the following additional tail identification (TA) code:

Table 15

a0 a1 a2	Tail contents	Restrictions
1 1 1	paging tail (P_T)	RFP only

"RFP only": means RFP transmissions only.

The FT shall be able to send and the PT shall understand long page messages (P_T type tail messages).

For the alphanumeric service the FT shall only use long page messages in normal paging mode. This paging mode is defined in the RFP paging procedure of ETS 300 175-3 [3].

The PT shall react correctly to long page messages. Detection and processing of paging messages is defined in the paging procedure of ETS 300 175-3 [3].

9.2.2 Alphanumeric service via the MAC C/L downlink service (case B1)

FT and PT shall support the requirements for incoming calls as defined in subclause 9.1.

FT and PT shall support the CL_F channel. To transmit or receive CL_F channel data the multiplex E32 shall be supported.

The FT shall be able to transmit, and the PT shall understand the following coding of the TA field of the A-field header:

Table 16

a0 a1 a2	Tail contents	Restrictions
0 1 0	identities information (N_T) on connectionless bearer	RFP only

"RFP only": means RFP transmissions only.

Following additional B-field identification codes in the A-field header are used for the C/L downlink service:

Table 17

a4, a5, a6	B Field Contents
0 1 0	E type, all CL_F
1 0 0	E type, not all CL_F
1 1 0	E type, all MAC control (unnumbered)

The FT shall be able to transmit and the PT shall understand these additional BA codes.

The FT shall be able to transmit and the PT shall understand the MAC B-field "null" message.

The FT and PT shall support the downlink connectionless procedure as defined in ETS 300 175-3 [3].

9.2.3 Alphanumeric service via the MAC C/L downlink and uplink services (case B2)

FT and PT shall support the requirements for the alphanumeric service via the MAC C/L downlink service as defined in subclause 9.2.2.

The FT shall support the CL_F channel.

NOTE: Even though this channel is not used by basic connections the PT decides on the C_F capability indication in the FP capabilities message (see subclause 8.4.2.2) if the CL_F channel is available (see C/L uplink procedure in ETS 300 175-3 [3]).

The PT shall be able to transmit and the FT shall understand the additional B-field identification codes defined in subclause 9.2.2.

The PT shall be able to transmit and the FT shall understand following subset of the broadcast and connectionless service M_T tail messages:

Table 18

a	b	c	d	meaning
0	0	0	0	CLF, first of 2 transmissions, half slot
0	0	0	1	CLF, first of 2 transmissions, full slot
0	0	1	0	reserved
0	0	1	0	CLF, first of 2 transmissions, double slot
0	0	1	1	reserved
0	1	0	0	CLF, last transmission, half slot
0	1	0	1	CLF, last transmission, full slot
0	1	1	1	reserved
0	1	1	0	CLF, last transmission, double slot
0	1	1	1	reserved
1	0	0	0	C/L single transmission, no CLF or CLS service
1	0	0	1	CLS service, first transmission
1	0	1	0	reserved
1	0	1	1	reserved

The PT shall be able to transmit and the FT shall understand the MAC B-field "null" message.

The FT and PT shall support the uplink connectionless procedure as defined in ETS 300 175-3 [3].

9.3 Encryption (features 33 and 34)

To provide encryption, in addition to the requirements stated in clause 8, also the ones in the following subclauses shall be fulfilled.

9.3.1 Connection oriented service procedures

The FT and PT shall support the MAC layer encryption procedure as specified in ETS 300 175-7 [7].

9.3.2 System information and multiframe marker (Q_T tail)

The FT shall be able to send and the PT shall understand also the following Q_T message (in addition to those identified in subclause 8.4.2.2):

Table 19

Q _H	System Information	Man	Freq
0110	multi-frame number	Yes	8

where :

MAN: mandatory transmission (Yes/No);
 FREQ: maximum repeat interval in multiframe, if implemented.

9.3.3 MAC control (M_T tails)

PT and FT shall understand and be able to send all of the encryption control messages as specified in ETS 300 175-3 [3].

9.4 Selection of bearer service (feature 53)

For connection oriented services only one bearer service is currently fully supported, MAC service type 1f without CF capability. The selection of bearer services requiring other MAC services are subject to further standardisation.

9.5 TARI request

To provide the means for TARI requests, the following requirements shall be fulfilled in addition to those stated in clause 8.

9.5.1 Non-continuous broadcast procedure

The FT and the PT shall support the A-field procedures for the non-continuous broadcast service as specified in ETS 300 175-3 [3].

9.5.2 MAC control (M_T tails)

PT and FT shall be able to transmit and shall understand following A-field tail messages:

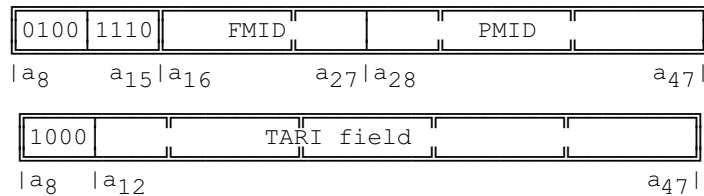

The first message belongs to the message set for broadcast and connectionless services and identifies the service.

The second message is used to carry the identity information. For the coding of the TARI field, refer to ETS 300 175-6 [6].

10 Requirements regarding the Physical Layer (PHL)

10.1 General

As specified in ETS 300 175-2 [2].

To carry the speech information, full slots shall be used.

10.2 Minimum Normal Transmit Power (NTP)

The nominal NTP shall be greater than 80 mW per simultaneously active transmitter as shown by the test verdict criteria and declaration of I-ETS 300 176 [9], subclauses 10.2.3, 10.2.4, and 10.2.5.

10.3 Radio receiver sensitivity

The RFP radio receiver sensitivity shall be - 86 dBm, or better.

10.4 Z-field

The Z-field shall be transmitted and received by RFPs and PTs.

10.5 Sliding collision detection

PT and FT shall be able to detect sliding collision on received packets.

Minimum criteria for sliding collision is defined as S- or Z-field failure. Early sliding collision detection may be supported by other means, e.g. signal strength measurements in the guard band.

The Z-field is defined to have failed if the received X- and Z-fields are not identical.

S-field failure is defined with some tolerance in order not to restrict the physical implementation of the word synchronization detector.

S-field failure may be indicated if there are 1 or more bit errors in bits s12 to s31 (errors in bits s0 to s11 shall be ignored). In all cases, S-field failure shall be indicated if 3 or more bit errors occur in bits s16 to s31.

11 Requirements regarding the speech transmission

11.1 General

The applicable requirements specified in ETS 300 175-8 [8] shall be applied.

11.2 User controlled volume control

A user-controlled volume control shall be provided in all PAP PP equipment, except where that equipment incorporates an adaptive volume control in the PP.

When adjusting the volume control from nominal to maximum setting, the decrease in RLR_H shall not be less than 6 dB.

11.3 PP ambient noise rejection capability feature

If PP ambient noise rejection capability is provided, the LSTR shall not be less than 15 dB.

Annex A (informative): Message sequence diagrams

The following diagrams show one valid interpretation of the public access profile protocols. Alternative interpretations are also possible.

A.1 Outgoing call establishment

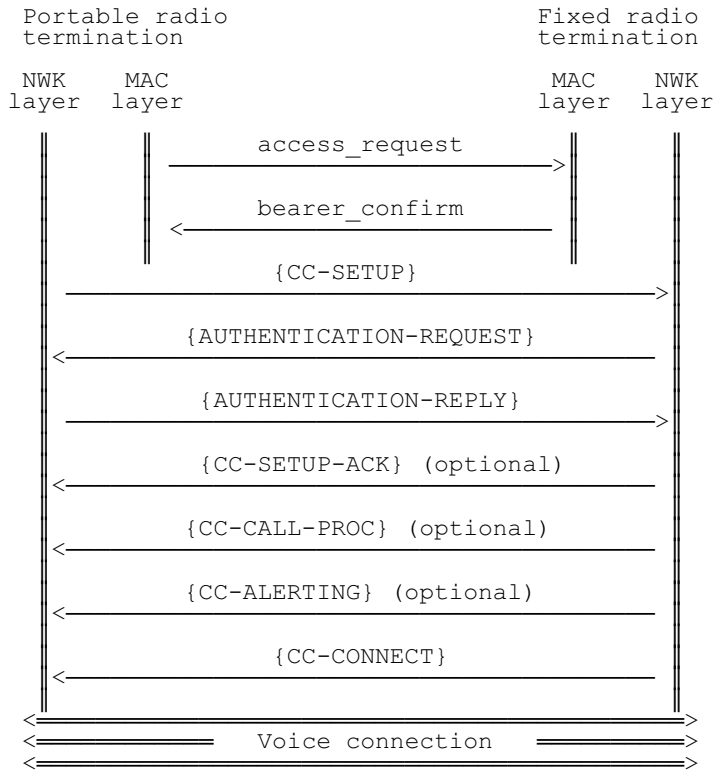

Figure A.1: Network layer messages are within { }

A.2 Incoming call establishment

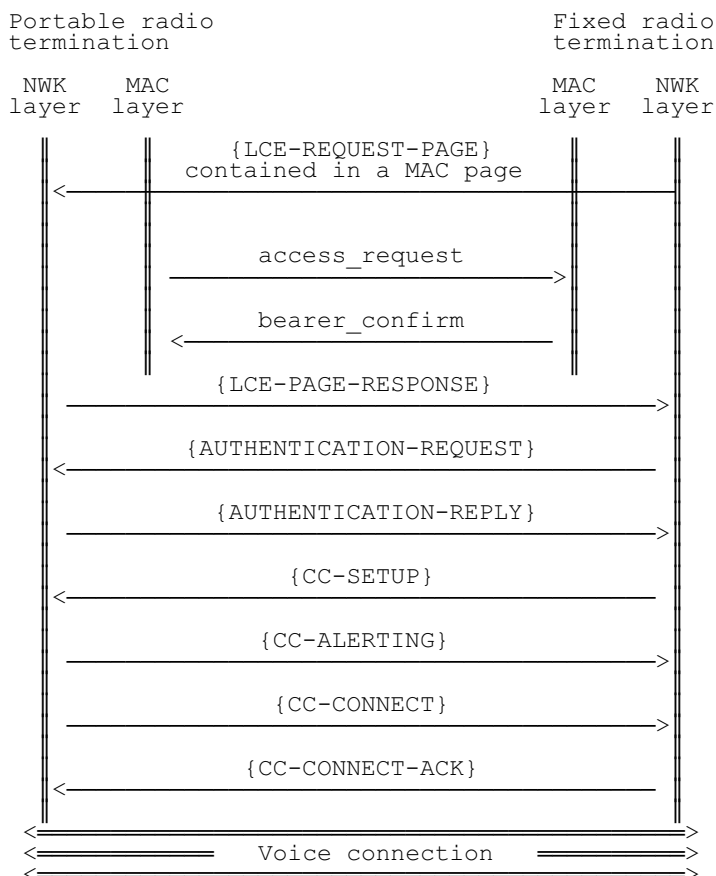

Figure A.2: Network layer messages are within { }

A.3 Release initiated by the fixed termination

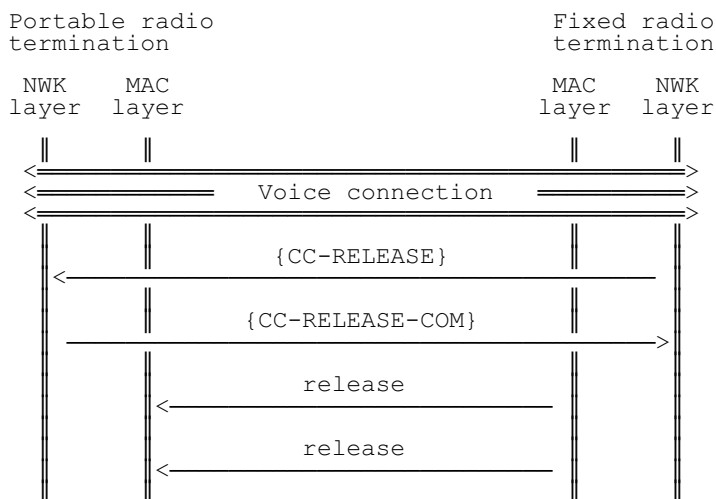

Figure A.3: Network layer messages are within { }

A.4 Release initiated by the portable termination

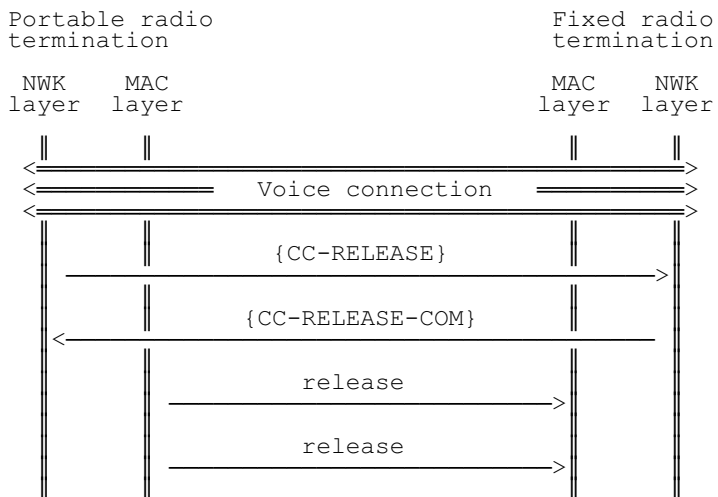

Figure A.4: Network layer messages are within { }

A.5 Location registration

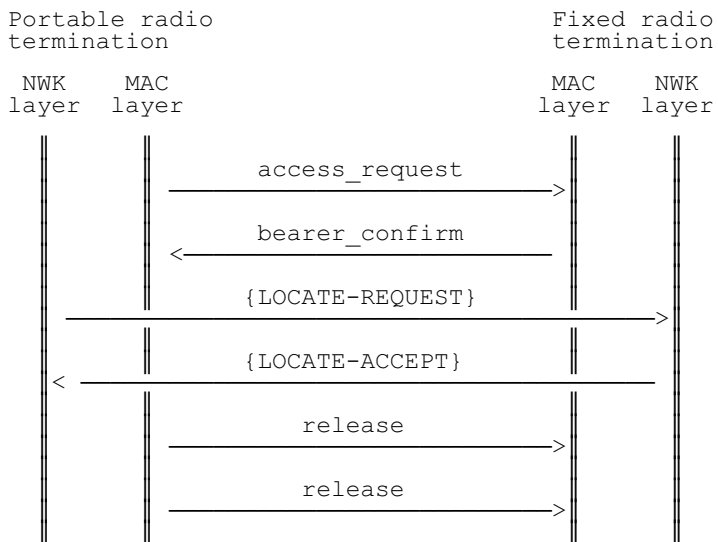

Figure A.5: Network layer messages are within { }

Annex B (informative): Set-up attributes codings

This annex is copied from annex E of ETS 300 175 [5], and is included here for ease of reference. In the event of any discrepancy, annex E of ETS 300 175-5 [5] shall define the normative codings.

Table B.1: PAP coding for <<call attributes>> information element

Octet	Information element field	Field value
3	Coding standard	DECT standard
	Network Layer Attributes	Public Access Profile
4	C-plane class	Class A; shared
	C-plane transfer rate	CS only
5	U-plane symmetry	Symmetric
	LU identification	LU1
6	U-plane class	Class 0 min_delay
	U-plane frame type	FU1

Table B.2: PAP coding for <<IWU attributes>> information element

Octet	Information element field	Field value
3	Coding standard	DECT standard
	Info. Transfer capability	Speech
4	Negotiation indicator	Not possible
	External connection type	Connection oriented
5	Transfer mode	Circuit mode
	Info. Transfer rate	32 kbps
6	Protocol identifier	User protocol ID
	User protocol ID	G.721 ADPCM

Annex C (informative): DECT standard authentication algorithm

The DECT standard authentication algorithm is only available on a restricted basis. For further information please contact ETSI.

Annex D (informative): DECT standard cipher

The DECT standard cipher is only available on a restricted basis. For further information please contact ETSI.

Annex E (informative): Relationship to DECT Generic Access Profile (GAP)

It is expected that ETS 300 175-9 will be withdrawn following publication of CTR22 (CTR for GAP), and subsequent withdrawal of CTR11 (CTR for PAP).

Annex F (informative): Bibliography

- ETR 043: "Radio Equipment and Systems (RES); Digital Enhanced Cordless Telecommunications (DECT); Common interface Services and facilities requirements specification".
- ETR 015: "Radio Equipment and Systems (RES); Digital Enhanced Cordless Telecommunications (DECT); Reference document".
- ETR 056: " Radio Equipment and Systems (RES); Digital Enhanced Cordless Telecommunications (DECT); System description document".
- ETR 042: "Radio Equipment and Systems (RES); Digital Enhanced Cordless Telecommunications (DECT); A guide to the DECT features that influence the traffic capacity and the maintenance of high radio link transmission quality, including the results of simulations".

History

Document history	
October 1992	First Edition
August 1995	Public Enquiry PE 90: 1995-08-21 to 1995-12-15
June 1996	Vote V 106: 1996-06-24 to 1996-08-30
September 1996	Second Edition