



EUROPEAN
TELECOMMUNICATION
STANDARD

ETS 300 175-8

September 1996

Second Edition

Source: ETSI TC-RES

Reference: RE/RES-03027-8

ICS: 33.060, 33.060.50

Key words: DECT, radio

**Radio Equipment and Systems (RES);
Digital Enhanced Cordless Telecommunications (DECT);
Common Interface (CI);
Part 8: Speech coding and transmission**

ETSI

European Telecommunications Standards Institute

ETSI Secretariat

Postal address: F-06921 Sophia Antipolis CEDEX - FRANCE

Office address: 650 Route des Lucioles - Sophia Antipolis - Valbonne - FRANCE

X.400: c=fr, a=atlas, p=etsi, s=secretariat - **Internet:** secretariat@etsi.fr

Tel.: +33 92 94 42 00 - Fax: +33 93 65 47 16

Copyright Notification: No part may be reproduced except as authorized by written permission. The copyright and the foregoing restriction extend to reproduction in all media.

© European Telecommunications Standards Institute 1996. All rights reserved.

Contents

Foreword		7
1	Scope	9
2	Normative references	9
3	Definitions and abbreviations	11
	3.1 Definitions	11
	3.2 Abbreviations	12
4	Configurations	13
	4.1 Reference configuration	13
	4.1.1 Basic configuration	13
	4.1.2 Portable Part (PP)	14
	4.1.2.1 Functional organization	14
	4.1.2.2 Volume control	15
	4.1.3 Fixed Part (FP)	15
	4.1.3.1 Digital interface	15
	4.1.3.2 Analogue interface	16
	4.1.3.3 FP adaptive volume control	16
	4.2 Test configurations	16
5	Encoding	17
	5.1 32 kbit/s full term (ADPCM)	17
	5.1.1 Algorithm	17
	5.1.2 Bit sequence	17
	5.2 Other codings	17
6	Transmission aspects	17
	6.1 Relative level	17
	6.2 Acoustic reference level	17
	6.3 Volume control	17
7	Speech performance characteristics	18
	7.1 PP frequency responses	18
	7.1.1 Sending	18
	7.1.2 Receiving	18
	7.2 PP sending and receiving loudness ratings	18
	7.2.1 Nominal values	18
	7.2.2 User-controlled volume control in PP	19
	7.2.3 PP adaptive volume control	19
	7.2.4 FP adaptive volume control	20
	7.3 Sidetone	20
	7.3.1 Talker sidetone	20
	7.3.2 Listener sidetone	20
	7.4 Terminal coupling loss	21
	7.4.1 Weighted Terminal Coupling Loss (TLCw)	21
	7.4.1.1 PP for the 3,1 kHz service (PSTN or ISDN)	21
	7.4.1.2 FP with 4-wire interface	21
	7.4.1.3 FP with analogue 2-wire interface	22
	7.4.1.4 PP for unrestricted 64 kbit/s service	22
	7.4.2 Stability loss	22
	7.4.2.1 Requirement	22
	7.4.2.2 Test conditions	22

	7.4.2.3	Fixed geometry PP.....	22	
	7.4.2.4	Variable geometry PP	22	
7.5		Distortion	23	
	7.5.1	Sending.....	23	
	7.5.2	Receiving	23	
	7.5.3	Sidetone	23	
	7.5.4	Recommended value for network planning	23	
7.6		Out of band signals.....	23	
	7.6.1	Sending (discrimination against out of band input signals).....	23	
	7.6.2	Receiving (spurious out of band signals)	23	
7.7		Noise.....	24	
	7.7.1	Sending.....	24	
	7.7.2	Narrow-band noise.....	24	
	7.7.3	Receiving	24	
	7.7.4	Level of sampling frequency (receiving)	24	
7.8		Acoustic shock	24	
	7.8.1	Continuous signal.....	24	
	7.8.2	Peak signal	24	
7.9		Delay.....	24	
	7.9.1	DECT network.....	24	
	7.9.2	PP.....	24	
	7.9.3	FP.....	24	
7.10		Network echo control	25	
7.11		PP ambient noise rejection	25	
8		Additional features	26	
8.1		Loudspeaking and hand-free facilities.....	26	
8.2		Tandem with mobile radio network.....	26	
	8.2.1	Tandem with GSM.....	26	
		8.2.1.1 Network echo control.....	26	
		8.2.1.2 Terminal coupling loss	26	
		8.2.1.3 The GSM mobile transmitter operates in continuous mode	26	
		8.2.1.4 The GSM mobile transmitter operates in discontinuous mode, DTX.....	26	
8.3		DECT connected to the GSM fixed network.....	27	
	8.3.1	Network echo control	27	
	8.3.2	Terminal coupling loss	27	
8.4		Wireless Relay Stations (WRS)	27	
	8.4.1	Modified FP network echo control requirements for implementation of 2 and 3 CRFP links in cascade	28	
		Annex A (informative): Description of "reference" echo control devices.....	29	
A.1		Handset echo	29	
	A.1.1	Overview	29	
		A.1.1.1 Connection to the PSTN/ISDN.....	29	
			A.1.1.1.1 Local and national calls.....	29
			A.1.1.1.2 Long distance connections with echo control devices in the PSTN/ISDN, e.g. calls via satellites	29
		A.1.1.2 Connection to the GSM network	30	
A.1.2		Implementation of the FP echo control function subclause 7.4.1.2 b.....	30	
	A.1.2.1	Suppression threshold.....	30	
	A.1.2.2	Static characteristics of activation control	31	
	A.1.2.3	Dynamic characteristics of activation control	31	
A.2		Network echo	31	
	A.2.1	Soft suppressor implementation of requirement 2 of subclause 7.10.....	32	
		A.2.1.1 Static characteristics.....	32	
		A.2.1.2 Dynamic characteristics.....	32	
	A.2.2	Additional echo control for a 2-wire interface of requirement 1 of subclause 7.10.....	32	

A.2.3	Echo canceller used for both requirements 1 and 2	33
Annex B (informative):	Local loop application	34
B.1	DECT tethered local loop replacement with 2-wire PP end system	34
B.1.1	TCLw requirements	34
B.1.2	Network echo.....	35
B.2	Quantization distortion considerations.....	35
Annex C (informative):	GSM Discontinuous Transmission (DTX), and Voice Activity Detection (VAD) ..	36
Annex D (informative):	Speech levels in relation to ambient room noise and examples of adaptive volume control settings	37
Annex E (informative):	Bibliography	38
History	39

Blank page

Foreword

This second edition European Telecommunication Standard (ETS) has been produced by the Radio Equipment and Systems (RES) Technical Committee of the European Telecommunications Standards Institute (ETSI).

This ETS forms part 8 of a series of 9 laying down the arrangements for the Digital Enhanced Cordless Telecommunications (DECT) Common Interface (CI).

- Part 1: "Overview".
- Part 2 "Physical layer (PHL)".
- Part 3 "Medium Access Control (MAC) layer".
- Part 4 "Data Link Control (DLC) layer".
- Part 5: "Network (NWK) layer".
- Part 6: "Identities and addressing".
- Part 7: "Security features".
- Part 8: "Speech coding and transmission".**
- Part 9: "Public Access Profile (PAP)".

Further details of the DECT system may be found in ETR 015, ETR 043, and ETR 056 (see annex E).

Transposition dates	
Date of adoption of this ETS:	6 September 1996
Date of latest announcement of this ETS (doa):	31 December 1996
Date of latest publication of new National Standard or endorsement of this ETS (dop/e):	30 June 1997
Date of withdrawal of any conflicting National Standard (dow):	30 June 1997

Blank page

1 Scope

This second edition European Telecommunication Standard (ETS) is part of the Digital Enhanced Cordless Telecommunications (DECT) Common Interface (CI) and specifies the speech coding and transmission requirements.

In order to ensure satisfactory interworking of different portable and fixed units, it is necessary to specify the transmission performance of the analogue information over the digital link. This requires not only use of a common speech algorithm, but also standardization of frequency responses, reference speech levels (or loudness) at the air interface and various other parameters.

This ETS applies to DECT equipment which includes all the necessary functions to provide real-time two-way speech conversation. A 3,1 kHz telephony teleservice conveyed over a DECT link (including Fixed Part (FP) and Portable Part (PP)) which is capable of being connected (directly or indirectly) to the public network access point has to comply with the requirements in this ETS.

Tethered fixed point local loop applications are not required to comply with the requirements of this part.

The speech performance characteristics defined in this ETS typically conform to ETS 300 085 [19], which specifies the overall performance between the handset acoustic interface and a 64 kbit/s A-law Pulse Code Modulated (PCM) digital network interface. The deviations from ETS 300 085 [19] are mainly due to the consequences of non-PCM coding and transmission delay.

The additional features described in clause 8 are those which are not included in ETS 300 085 [19], but which are likely to occur in a DECT system: analogue interface, loudspeaking and hand-free facilities, tandeming with a mobile radio network. Headsets are not covered by the present specifications.

For the DECT systems which connect to the Public Switched Telephone Network (PSTN) via an analogue interface, this ETS includes the basics on which the national specifications can be built, referring to ETS 300 001 [20] (which specifies the connection of terminal equipments to the PSTN via a 2-wire analogue interface) and the appropriate national standard.

ETSI/STC TM5 has prepared a technical report, ETR 041, to be used as a guide for network planning.

A summary of the control and the use of the DECT echo control functions, to guide on need for options to manufacturers and installers, is found in the supplementary services clause of ETR 056.

Information concerning test methods can be found in I-ETS 300 176 [9]. The test methods take into account that DECT is a digital system.

2 Normative references

This ETS incorporates, by dated or undated reference, provisions from other publications. These normative references are cited at the appropriate places in the text and the publications are listed hereafter. For dated references, subsequent amendments to or revisions of any of these publications apply to this ETS only when incorporated in it by amendment or revision. For undated references the latest edition of the publication referred to applies.

- [1] ETS 300 175-1 (1996): "Radio Equipment and Systems (RES); Digital European Cordless Telecommunications (DECT); Common Interface (CI); Part 1: Overview".
- [2] ETS 300 175-2 (1996): "Radio Equipment and Systems (RES); Digital European Cordless Telecommunications (DECT); Common Interface (CI); Part 2: Physical Layer (PHL)".
- [3] ETS 300 175-3 (1996): "Radio Equipment and Systems (RES); Digital European Cordless Telecommunications (DECT); Common Interface (CI); Part 3: Medium Access Control (MAC) layer".

- [4] ETS 300 175-4 (1996): "Radio Equipment and Systems (RES); Digital European Cordless Telecommunications (DECT); Common Interface (CI); Part 4: Data Link Control (DLC) layer".
- [5] ETS 300 175-5 (1996): "Radio Equipment and Systems (RES); Digital European Cordless Telecommunications (DECT); Common Interface (CI); Part 5: Network (NWK) layer".
- [6] ETS 300 175-6 (1996): "Radio Equipment and Systems (RES); Digital European Cordless Telecommunications (DECT); Common Interface (CI); Part 6: Identities and addressing".
- [7] ETS 300 175-7 (1996): "Radio Equipment and Systems (RES); Digital European Cordless Telecommunications (DECT); Common Interface (CI); Part 7: Security features".
- [8] ETS 300 444: "Radio Equipment and Systems (RES); Digital European Cordless Telecommunications (DECT): Generic Access Profile (GAP)".
- [9] I-ETS 300 176: "Radio Systems and Equipment (RES); Digital European Cordless Telecommunications (DECT) Approval test specification".
- [10] CCITT Recommendation G.101 (1988): "The transmission plan".
- [11] CCITT Recommendation G.131 (1988): "Stability and echo".
- [12] CCITT Recommendation G.164 (1988): "Echo suppressors".
- [13] CCITT Recommendation G.165 (1988): "Echo cancellers".
- [14] CCITT Recommendation G.701 (1988): "Vocabulary of digital transmission and multiplexing, and pulse code modulation (PCM) terms".
- [15] CCITT Recommendation G.726 (1991): "40, 32, 24, 16 kbit/s adaptive differential pulse code modulation (ADPCM)".
- [16] CCITT Recommendation I.241 (1988): "Teleservices supported by an ISDN".
- [17] CCITT Recommendation P.10 (1988): "Vocabulary of terms on telephone transmission quality and telephone sets".
- [18] CCITT Recommendation P.34 (1988): "Transmission characteristics of hands-free telephones".
- [19] ETS 300 085: "Integrated Services Digital Network (ISDN): 3,1 kHz telephony teleservice; Attachment requirements for handset terminals" (text relevant for NET 33).
- [20] ETS 300 001: "Attachments to Public Switched Telephone Network (PSTN); General technical requirements for equipment connected to an analogue subscriber interface in the PSTN" (Candidate NET 4).
- [21] CCITT Recommendation G.113 (1988): "Transmission impairments".
- [22] CCITT Recommendation G.111 (1988): "Loudness ratings (LRs) in an international connection".
- [23] ETS 300 540: "Digital cellular telecommunications system (Phase 2); Transmission planning aspects of the speech service in the GSM Public Land Mobile Network (PLMN) system (GSM 03.50)".

3 Definitions and abbreviations

3.1 Definitions

For the purposes of this ETS, the following definitions apply:

Central Control Fixed Part (CCFP): See ETS 300 175-1 [1].

Cordless Radio Fixed Part (CRFP): See ETS 300 175-1 [1].

DECT Network (DNW): See ETS 300 175-1 [1].

double duplex bearer : See ETS 300 175-1 [1].

End System (ES): See ETS 300 175-1 [1].

fixed geometry Portable Part (PP): A PP in which the electro-acoustic transducers and their associated acoustic components are held in fixed relative positions and/or orientations during all on-line conditions and test conditions of the PP.

Fixed Part (DECT Fixed Part) (FP): See ETS 300 175-1 [1].

Fixed radio Termination (FT): See ETS 300 175-1 [1].

Generic Access Profile (GAP): A standard in addition to the DECT CI that ensures interoperability between FPs and PPs from different manufacturers.

handset echo: The echo, perceptible by the far-end user, resulting from the coupling between the receiving and sending directions of the handset, mostly due to acoustic coupling between transducers. It is particularly objectionable in communications including a satellite and an echo canceller, as the DECT handset echo may be out of range of the echo canceller.

network (telecommunication network): See ETS 300 175-1 [1].

network echo: The echo, perceptible by the DECT user, resulting from reflections in the network. It is mostly due to hybrid impairments at both ends of the communication.

operator (DECT operator): See ETS 300 175-1 [1].

Portable Handset (PHS): See ETS 300 175-1 [1].

Portable Part (DECT Portable Part) (PP): See ETS 300 175-1 [1].

Portable radio Termination (PT): See ETS 300 175-1 [1].

public: See ETS 300 175-1 [1].

public access service: See ETS 300 175-1 [1].

Radio Fixed Part (RFP): See ETS 300 175-1 [1].

Repeater Part (REP) : See ETS 300 175-1 [1].

service provider (telecommunications service provider): See ETS 300 175-1 [1].

telephony service: See CCITT Recommendation I.241 [16].

user (of a telecommunication network): See ETS 300 175-1 [1].

variable geometry PP: A PP that allows the position and/or orientation of its electro-acoustic transducers and their associated acoustic components to be changed during all on-line conditions of the PP.

Wireless Relay Station (WRS): See ETS 300 175-1 [1].

3.2 Abbreviations

For the purposes of this ETS, relevant definitions and abbreviations in CCITT Recommendations P.10 [17] and G.701 [14] apply. In addition the following abbreviations apply:

ADPCM	Adaptive Differential Pulse Code Modulation
ARL	Acoustic Reference Level
CCFP	Central Control Fixed Part
CI	Common Interface
CFRP	Cordless Radio Fixed Part
CLRR	Circuit Loudness Rating, Receiving
CLRS	Circuit Loudness Rating, Sending
CODEC	Coder-Decoder
CRFP	Cordless Radio Fixed Part
CSPDN	Circuit Switched Public Data Network
dBm	dB relative to 1 milliwatt
dBm0	The absolute power level in decibels referred to a point of zero relative level
dBr	The relative power level in decibels
DECT	Digital Enhanced Cordless Telecommunications
DNW	DECT Network
ERP	Ear Reference Point
ES	End System
FP	Fixed Part
FT	Fixed radio Termination
GAP	Generic Access Profile
ISDN	Integrated Services Digital Network
LE	Local Echo
LSTR	Listener Sidetone Rating
MRP	Mouth Reference Point
NLP	Non-Linear Processor
NWK	Network
OLR	Overall Loudness Rating
P(A)BX	Private (Automatic) Branch Exchange
PAP	Public Access Profile
PHS	Portable Handset
PP	Portable Part
PSPDN	Packet Switched Public Data Network
PSTN	Public Switched Telephone Network
PT	Portable radio Termination
PTN	Private Telecommunication Network
ReFP	Reference Fixed Part
RePP	Reference Portable Part
REP	REpeater Part
RFP	Radio Fixed Part
RLR _H	Receiving Loudness Rating of the Handset
SLR _H	Sending Loudness Rating of the Handset
TCL _w	weighted Terminal Coupling Loss
TELR	Talker's Echo Loudness Rating
STMR	Sidetone Masking Rating
QDU	Quantization Distortion Unit
WRS	Wireless Relay Station

4 Configurations

4.1 Reference configuration

4.1.1 Basic configuration

The basic reference configuration for voice transmission over DECT is shown in figure 1.

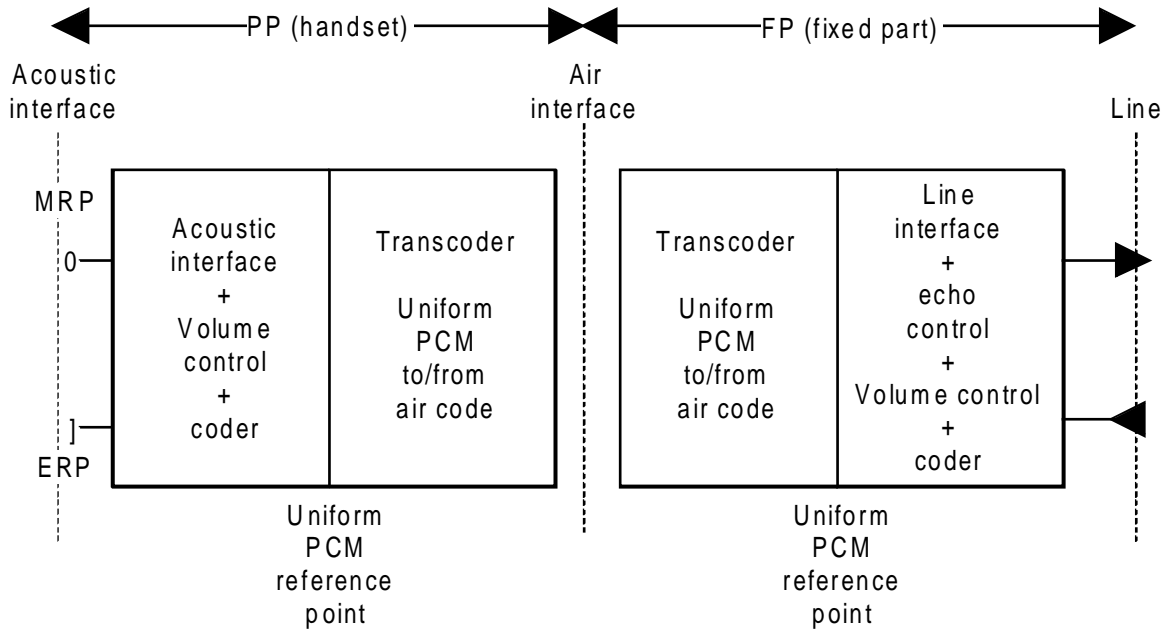

Figure 1: Basic reference configuration

The PP and the FP are delimited by physical interfaces:

- Acoustic:
 - from the PP towards the speaker-listener, with the Ear and Mouth Reference Points (ERP and MRP).
- Air(RF):
 - the interface between PP and FP.
- Line:
 - the interface from the FP towards the network.

Uniform PCM reference points shall be introduced in both the PP and the FP to materialize the limits of the transmission segment which is affected by the air interface coding scheme. This allows the transmission requirements to be specified independently from the coding at the air interface. The various transcoding algorithms are level-transparent, i.e. with an encoder and decoder connected in tandem, the "levels" of the digital signals at the uniform PCM input of the encoder and output from the decoder are identical. In a particular implementation, the reference points may be embedded within an IC, and thus will not physically accessible.

Each of the three sections thus delimited deals with distinct functions:

- a) the PP electro-acoustic section (between acoustic interface and PP uniform PCM reference point) which includes the acoustic interface, the volume control and the analogue to digital conversion;
- b) the air-code section (between PP and FP uniform PCM reference points) considers the transcoding between uniform PCM and the air-code, as well as the transmission over the air interface;
- c) the FP line interface section (between FP uniform PCM reference point and line interface) comprises the interface to the line, digital or analogue, and the FP voice processing, e.g. echo control.

Typically, the transmission features shall conform to ETS 300 085 [19] for the PP electro-acoustic section, and the line interface section in the case of digital interface. In the case of analogue interface, the line interface section realises the adaptation to ETS 300 001 [20] and to national standards.

4.1.2 Portable Part (PP)

4.1.2.1 Functional organization

Figure 2 represents the basic functional organization of a PP from the voice transmission point of view:

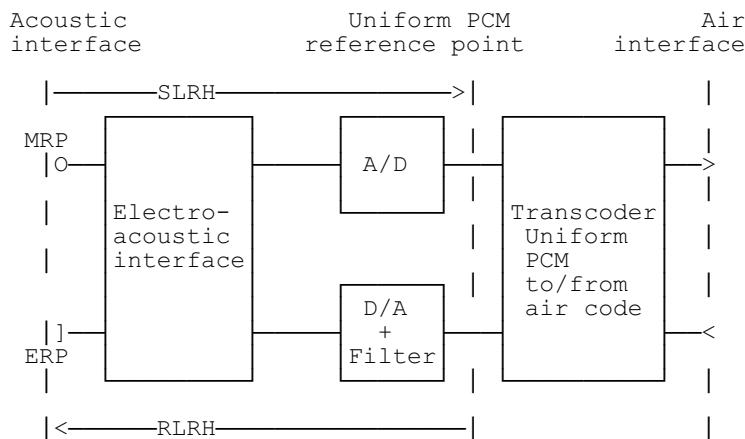

Figure 2: PP functional organization

The various functions represented in figure 2 are:

- a) the electro-acoustic function, which performs the interface to the transducers and the volume control. The Handset Loudness Ratings (SLR_H) and (RLR_H) are defined between the acoustic interface and the uniform PCM reference point;
- b) the analogue to digital and digital to analogue coding to the uniform PCM reference point;
- c) the transcoder between uniform PCM and air-code.

4.1.2.2 Volume control

The volume control facility is optional, and can be implemented in a number of different ways:

- 1) in the simplest implementation, it affects only the receiving level and is under the manual control of the PP user;
- 2) the volume adjustment may also be adaptive, e.g. taking into account the average level of ambient noise at the MRP;
- 3) the volume control may affect both receiving and sending levels in opposite directions. This has the advantage of reducing the effect on the terminal coupling loss. Such an implementation would fit a noisy environment, as the need for an increased receiving volume is likely to come from a loud ambient noise, and it is then combined with a loud speech level.

4.1.3 Fixed Part (FP)

4.1.3.1 Digital interface

Figure 3 shows the functional organization of a FP with a digital interface:

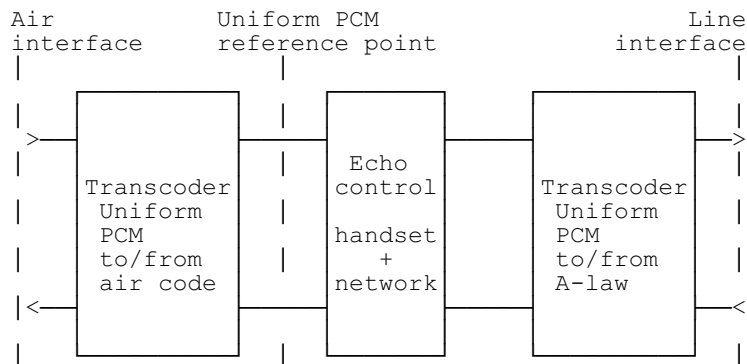

Figure 3: FP functional organization

The various functions represented in figure 3 are:

- a) a transcoder between air-code and uniform PCM;
- b) an echo control function which processes echoes coming back from both the handset and the network. It provides additional losses that compensate for the increased length of the echo path due to the DECT transmission delay over the air interface;
- c) a transcoder from uniform PCM to A-law PCM towards the line interface.

4.1.3.2 Analogue interface

The organization of a FP with an analogue interface is shown in figure 4.

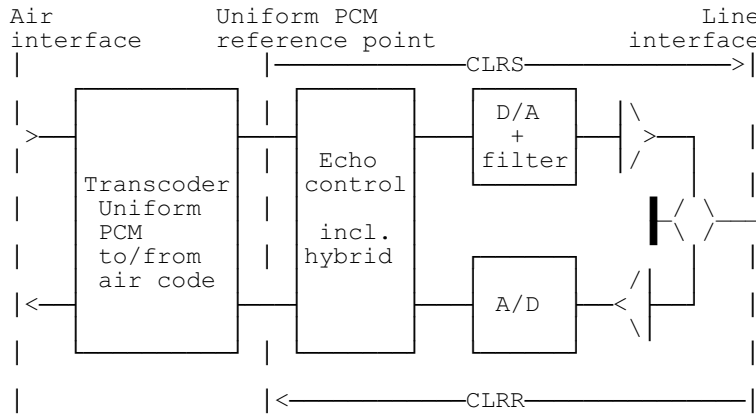

Figure 4: FP with an analogue interface

The various functions represented in figure 4 are:

- a) the line interface comprises the digital to analogue coder-decoder and the adaptation to the line, that can be either 2- or 4-wire. The Circuit Loudness Ratings (CLRR and CLRS) are defined between uniform PCM reference point and the line interface;
- b) in the case of a 2-wire line, the network echo controller deals with the local hybrid echo, which is superimposed on the network echo in a manner similar to the digital line interface.

NOTE: Due to different transmission characteristics of the 2-wire local access in European countries, it is recommended that careful attention is paid to the transmission specification of the 2-wire FP interface, particularly in respect of transmission loss and impedance.

4.1.3.3 FP adaptive volume control

An adaptive dual volume adjustment, as described in subclause 4.1.2.2, may optionally be implemented into the FP, for base stations where the associated PPs may be used in a noisy environment (e.g. public access).

4.2 Test configurations

A DECT system comprises a FP and a PP. As these parts are not always purchased together, it is a requirement that either the complete system or each of the two separate parts shall be capable of being tested (see I-ETS 300 176 [9]).

5 Encoding

5.1 32 kbit/s full term (ADPCM)

5.1.1 Algorithm

The speech coding algorithm shall conform to CCITT Recommendation G.726 [15] for 32 kbit/s Adaptive Differential Pulse Code Modulation (ADPCM).

The A-law companding and synchronous tandem adjustment may be omitted in FPs with an analogue line interface and in PPs.

NOTE: CCITT Recommendation G.726 [15] 32 kbit/s ADPCM codecs support the use of the voice channel for telefax of group 2 and group 3. For group 3 the data speed, which is automatically negotiated, is limited to 4,8 kbit/s.

5.1.2 Bit sequence

The ADPCM words comprised in each burst shall be transmitted in chronological order, and with the most significant bit transmitted first within each word.

5.2 Other codings

No other coding scheme is permitted at this time. When introducing a new coding the following speech performance characteristics shall be reviewed:

- frequency response;
- distortion;
- delay; and
- if the latter is widely affected, terminal coupling loss and network echo control.

6 Transmission aspects

6.1 Relative level

The digital line interface is a 0 dBr point according to CCITT Recommendation G.101 [10]. As the various digital transcoding algorithms are essentially loss-less, the relative level is constant over the whole digital path in the PP and the FP.

6.2 Acoustic reference level

The acoustic reference level is defined as the acoustic level which corresponds to a level of -10 dBm₀ at the digital interface.

6.3 Volume control

Unless stated otherwise, if a user-controlled volume control is provided at the PP, the requirements apply for all positions of the volume control, and the compliance tests shall be carried out at the maximum setting of this volume control.

NOTE: The testing of a PP with a dual or an adaptive volume control requires further study.

7 Speech performance characteristics

7.1 PP frequency responses

7.1.1 Sending

The sending sensitivity-frequency response (from MRP to the digital interface) shall be within a mask as defined in table 1.

Table 1: Sending sensitivity-frequency mask

Frequency (Hz)	Upper limit (dB)	Lower limit (dB)
100	- 12	
200	0	
300	0	- 12
1 000	0	- 6
2 000	4	- 6
3 000	4	- 6
3 400	4	- 9
4 000	0	

NOTE: All dB levels are on an arbitrary scale.

7.1.2 Receiving

The receiving sensitivity-frequency response (from the digital interface to the ERP) shall be within a mask as defined in table 2.

Table 2: Receiving sensitivity-frequency mask

Frequency (Hz)	Upper limit (dB)	Lower limit (dB)
100	- 12	
200	0	
300	2	- 7
500	NOTE 1	- 5
1 000	0	- 5
3 000	2	- 5
3 400	2	- 10
4 000	2	

NOTE 1: The limit at intermediate frequencies lies on a straight line drawn between the given values on a log (frequency) - linear (dB) scale.

NOTE 2: All dB levels are on an arbitrary scale.

7.2 PP sending and receiving loudness ratings

7.2.1 Nominal values

The nominal values are:

- Sending Loudness Rating (SLR_H) = 7 dB; and
- Receiving Loudness Rating (RLR_H) = 3 dB.

There is a manufacturing tolerance of $\pm 3,5$ dB on both RLR_H and SLR_H.

NOTE: CCITT/ITU-T test methods on loudness ratings are valid only for codecs that can transmit sinusoids without excessive distortion.

7.2.2 User-controlled volume control in PP

Two types of user-controlled volume control shall be permitted.

A user-controlled volume control shall be provided in all PP equipment, except where an adaptive volume control is incorporated in the PP.

When adjusting the volume control from nominal to maximum setting, the decrease in RLR_H shall be not less than 6dB.

Where user controlled volume control is provided instead of an adaptive volume control, adjust the volume control to the setting (nominal) where the RLR is closest to its nominal value. At this setting the RLR_H and SLR_H shall simultaneously meet the values given in subclause 7.2.1, including the tolerances. A "joint acting" volume control is where the PP can simultaneously change the values of SLR and RLR in opposite directions.

The RLR_H and SLR_H shall not exceed the limits given in tables 5 and 6.

Table 3: Absolute limits for "joint-acting" volume control

Volume setting	Maximum	Minimum
RLR_H	- 13 dB	19 dB
SLR_H	17 dB	3 dB

Table 4: Absolute limits for a receiving volume control

Volume setting	Maximum	Minimum
RLR_H	- 13 dB	19 dB

NOTE 1: Minimum setting: The setting where the RLR has its maximum value

Maximum setting: The setting where the RLR has its minimum value

NOTE 2: A user-controlled volume control should include an automatic reset function that ensures that the default setting for each new call is no higher than the nominal setting.

NOTE3: Analogue networks generally require higher receive levels (lower RLR) than digital networks (ISDN). This is to compensate for old long lossy analogue lines that still exist in many PSTNs. This gives an interworking problem between analogue networks and terminals that use digital codecs as in DECT systems and ISDN terminals. Most of the calls do not have lossy lines, and then the receive signal becomes very high, which could cause distortion in the A/D converters and also lower the margin for the wanted terminal echo loss. The best solution is to adjust the general national requirements for analogue terminals, so that 4 to 6 dB higher RLR is allowed when a DECT system is the terminal of an analogue connection to the PSTN. This would not violate any national planning rules, since each DECT PP has at least + 6 dB volume control to compensate for any lossy connection. Some national administrations have already implemented this principle.

7.2.3 PP adaptive volume control

The PP shall inform the FP if an adaptive volume control is implemented in the PP. Subclause 7.7.41 in ETS 300 175-5 [5] describes how this shall be done.

This function is for further study and may follow GSM, or other, specifications when available.

7.2.4 FP adaptive volume control

An adaptive volume control, depending on the level of environmental noise at the PP, may be implemented into the FP. The gain variation shall be symmetrical, i.e. the increase in the receiving direction shall be equal to the decrease in the sending direction.

If the PP adaptive volume control feature is implemented then the FP adaptive volume control feature shall be disabled.

NOTE 1: The PP ambient noise level is calculated in the FP based upon the minimum ambient noise rejection requirement as specified in subclause 7.11.

NOTE 2: For an FP with an analogue interface, problems of saturation may occur depending on national RLR values.

See annex D for further information.

7.3 Sidetone

7.3.1 Talker sidetone

The sidetone path shall be implemented in the PP.

The nominal value of the Sidetone Masking Rating (STMR) shall be 13 dB. There is a manufacturing tolerance of - 3 dB to + 5 dB. The requirement shall be met with SLR_H and RLR_H corrected to the nominal values of SLR_H and RLR_H .

NOTE: It is recommended that the sidetone level is independent of the receiving volume control.

7.3.2 Listener sidetone

The value of the LSTR shall not be less than 10 dB referred to the nominal values of SLR_H and RLR_H .

For PPs with noise rejection capability as declared by the applicant, the value of the LSTR shall not be less than 15 dB referred to the nominal values of SLR_H and RLR_H .

Alternatively the value of the weighted average D of the difference of the send sensitivities between diffuse and direct sound shall be measured and shall not be less than -5 dB and with noise rejection the weighted average D shall not be less than +0 dB. One of both alternatives shall be declared by the applicant.

NOTE: The noise rejection capability option is recommended for PPs used in noisy environments.

PPs with declared noise rejection capability option shall indicate this to the FP before or at call set-up by including this information in the <<TERMINAL CAPABILITY>> information element. See ETS 300 175-5 [5] subclause 7.7.41.

7.4 Terminal coupling loss

The PP shall be suspended in free air.

7.4.1 Weighted Terminal Coupling Loss (TLCw)

7.4.1.1 PP for the 3,1 kHz service (PSTN or ISDN)

For a PP that is designed to provide the 3,1 kHz service, either on ISDN or PSTN, the weighted Terminal Coupling Loss (TCLw) defined from the PP digital input to the PP digital output shall meet one of the following options:

- a) $TCLw > 46$ dB at nominal setting of the volume control corrected to the nominal values of $RLRH$ and $SLRH$. For all positions of volume control the $TCLw$ shall not be less than 35 dB.

NOTE This is the recommended option.

- b) $TCLw > 34$ dB.

If the PP is of type a) then it shall send this information "Full TCL" to the FP as defined in ETS 300 175-5 [5], subclause 7.7.41 before or at call set-up.

If the FP receives no information concerning the $TCLw$ value of the PP, the FP shall default to the assumption that the PP is of type b).

7.4.1.2 FP with 4-wire interface

The FP echo control functions described below shall be connected or disabled depending on a message from the PP or depending on call routing information and on type of service. It is recommended to disable them when it is known that the one-way delay of the connection is less than 25 ms excluding the DECT delay (e.g. internal Private Automatic Branch eXchange (PABX) connections). They may be disabled if the PP has $TCLw > 46$ dB.

A FP with a 4-wire interface (analogue or digital) shall meet at least one of the two following requirements:

- a) artificial echo loss:
 - an artificial echo path shall be implemented into the FP between the line input and the line output, as shown in figure 5. The loss of that echo path shall be $24 \text{ dB} \pm 2 \text{ dB}$.

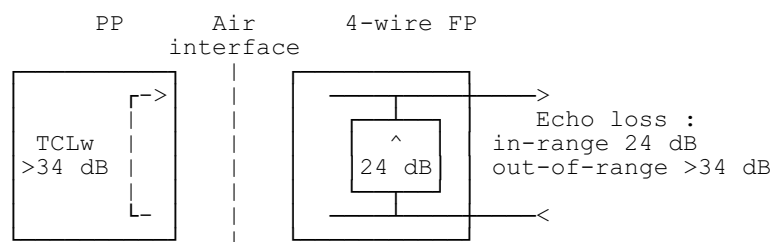

NOTE 1: The artificial echo simulates the echo from a very good analog 2-wire telephone. When a public network operator uses an echo canceller in the network (e.g. for a satellite link), the artificial echo loss path provides an in-range echo to ensure that the echo canceller and its Non-Linear Processor (NLP) is active. The NLP cancels the 34 dB DECT handset echo. See annex A, subclause A.1.1.

In some countries the echo cancellers in the public network do not depend on the artificial echo path to activate the NLP. Installations in such countries could have the artificial echo path permanently disabled.

Figure 5: Artificial echo path in a 4-wire FP

b) echo control device:

- an echo control device shall be implemented into the FP. The weighted Terminal Coupling Loss (TCLw) of the DECT system, defined from the FP line input to the FP line output, shall be at least 46 dB.

NOTE 2: Option a) is the option normally used for connections to the PSTN/ISDN. Option b) is needed, e.g. for tandem connection with GSM, subclauses 8.2.1 and 8.3.2. Annex A, subclause A.1.2 provides, for guidance and illustration, the description of a NLP implementation of option b). The control range for an echo canceller and hangover time for an NLP should be greater than or equal to 40 ms. A soft suppressor implementation is not recommended.

NOTE 3: The connect/disable function for options a) and b) is required for approval testing under I-ETS 300 176 [9]. Messages from the PP with control information are defined in ETS 300 175-5 [5] subclause 7.7.16.

7.4.1.3 FP with analogue 2-wire interface

There is no specific requirement on a FP with an analogue 2-wire interface to the PSTN/ISDN.

7.4.1.4 PP for unrestricted 64 kbit/s service

The unrestricted 64 kbit/s service is outside the scope of this ETS.

7.4.2 Stability loss

7.4.2.1 Requirement

In the test conditions described below the attenuation from the digital input to the digital output shall be at least 6 dB at all frequencies in the range of 200 Hz to 4 000 Hz.

7.4.2.2 Test conditions

7.4.2.3 Fixed geometry PP

The handset shall be lying on, and the transducers facing, a hard surface.

7.4.2.4 Variable geometry PP

The equipment shall be capable of meeting the requirement in at least one of the two following conditions:

- a) if it is possible to position the earpiece in front of the mouthpiece with a distance of 150 mm between the front planes of each, the requirement shall be met in this relative position and in the just off-hook position;
- b) if the relative movement and orientation of the acoustic and electro-magnetic elements are limited by means of a hinge or similar mechanism, the requirement shall be met in any relative position and orientation that can be achieved whilst the PP is in active condition, i.e. a communication is established over the air interface.

7.5 Distortion

7.5.1 Sending

The ratio of signal to total distortion (harmonic and quantizing) measured at the line interface shall not be less than 35 dB.

7.5.2 Receiving

The ratio of signal to total distortion (harmonic and quantizing) measured at the ERP shall not be less than 33 dB.

7.5.3 Sidetone

The third harmonic distortion generated by the PP shall not be greater than 10 %.

7.5.4 Recommended value for network planning

According to CCITT Recommendation G.113 [21], the PCM-to-ADPCM-to-PCM transcoding introduces 2,5 QDU (quantizing distortion units). Therefore, the following values shall be taken into account for network planning purpose:

- 3 QDU if the FP interfaces to a digital line, or 3,5 QDU if the FP interfaces to an analogue line. For further information see ETR 041.

7.6 Out of band signals

7.6.1 Sending (discrimination against out of band input signals)

With any sine-wave signal above 4,6 kHz and up to 8 kHz applied at the MRP at a level of - 4,7 dBPa, the level of any image frequency produced at the digital interface shall be below a reference level obtained at 1 kHz (- 4,7 dBPa at MRP) by at least the amount in dB specified in table 5.

Table 5: Discrimination levels - sending

Applied sine wave frequency	Limit (minimum)
4,6 kHz	30 dB
8,0 kHz	40 dB

The limits at intermediate frequencies lie on a straight line drawn between the given values on a log (frequency) - linear (dB) scale.

7.6.2 Receiving (spurious out of band signals)

With a digitally-simulated sine-wave signal in the frequency range of 300 Hz to 3 400 Hz at a level of -10 dBm0 applied at the digital interface, the level of spurious out-of-band image signals in the frequency range of 4,6 kHz to 8 kHz measured selectively at the ERP shall be lower than the in-band acoustic level produced by a digital signal at 1 kHz set at the level specified in table 6.

Table 6: Discrimination levels - receiving

Image signal frequency	Equivalent input level
4,6 kHz	- 35 dBm0
8,0 kHz	- 45 dBm0

The limits at intermediate frequencies lie on a straight line drawn between the given values on a log (frequency) - linear (dB) scale.

7.7 Noise

7.7.1 Sending

The noise produced by the apparatus in the sending direction shall not exceed - 64 dBm_{0p}.

7.7.2 Narrow-band noise

The narrow-band noise (due to TDMA) produced by the apparatus in the sending direction, and contained within any 10 Hz bandwidth between the frequency limits 300 to 3 400 Hz, shall not exceed - 73 dBm₀.

7.7.3 Receiving

If no user-controlled receiving volume control is provided, or if it is provided, at the setting where the RLR_H is equal to the nominal value, the noise produced by the apparatus and measured at the ERP shall not exceed - 54 dBPa (A).

7.7.4 Level of sampling frequency (receiving)

The level of the 8 kHz measured selectively at the ERP shall be less than - 70 dBPa.

7.8 Acoustic shock

7.8.1 Continuous signal

With a digitally encoded signal representing the maximum possible signal level at the digital interface, the sound pressure level at the ERP shall not exceed 24 dBPa (rms unweighted).

7.8.2 Peak signal

The receiving equipment shall limit the peak sound pressure at the ERP to less than 36 dBPa under any continuous or transient condition.

7.9 Delay

7.9.1 DECT network

The sum of the delays from the MRP to the digital line interface and from the digital line interface to the ERP (round-trip delay) shall not exceed 27,5 ms. If an analogue line interface is provided, the delay shall not exceed 28 ms including the A/D and D/A converters at the interface to the external network.

7.9.2 PP

The sum of the delays from the MRP to the air interface and from the air interface to the ERP (round-trip delay) shall not exceed 18,5 ms. This value includes the 5 ms delay of the reference FP looping back the ADPCM digital signal towards the PP.

7.9.3 FP

The sum of the delays from the digital line interface to the air interface and from the air interface to the digital line interface (round-trip delay) shall not exceed 19 ms. This value includes the 5 ms delay of the reference PP looping back the ADPCM digital signal towards the FP.

7.10 Network echo control

The network echo shall be controlled by inserting into the receiving speech path of the FP an echo loss meeting the requirements as defined in table 7.

Table 7: Network echo control mask

Echo path (2-way)			
Requirement 1	- 0 to 4 ms	TELR	≥ 24 dB
Requirement 2	- 0 to 70 ms	Extra echo loss	≥ 9 dB

Requirement 1 applies only to FP with an analogue 2-wire line interface. Requirement 2 applies for both 2-wire and 4-wire line interfaces. If the echo control device in the FP contains a soft suppressor, it is recommended to not suppress more than 12 dB.

The 24 dB TELR requirement corresponds to 14 dB weighted Echo Loss, LE, at the uniform PCM reference point of the FP. This requirement shall be met for the whole range of 2-wire cable equivalents and termination impedances specified by the national authority. See I-ETS 300 176 [9].

No recommendation is made for any particular implementation of the echo control device. For guidance and illustration, a reference soft suppressor that meets requirement 2 is described in annex A, subclause A.2.1, and a reference echo canceller that meets requirement 1, is described in annex A, subclause A.2.2.

Depending on routing information and on type of service, it shall be possible to connect and disable each of the echo control functions which perform the respective requirements 1 and 2.

The echo device implemented to meet requirement 2 may be disabled, or its loss may be reduced, in accordance with optionally available routing information, e.g. connections within a PABX, or a 4-wire connection via the PSTN/ISDN to an ISDN terminal.

NOTE: The connect/disable function for requirements 1 and 2 is required for approval testing (see I-ETS 300 176 [9]). Messages from the PP with control information are defined in ETS 300 175-5 [5], subclause 7.7.16.

7.11 PP ambient noise rejection

The PP ambient noise rejection performance is defined by the D value as described in CCITT Recommendation G.111 [22]. The D value is not measured, but a value is required for insertion in the FP adaptive volume control algorithm. The D value is derived from the STMR and LSTR specifications.

The FP adaptive volume control shall use the following values:

- a) D = - 3 for PPs without declared noise rejection capability;
- b) D = + 2 for PPs with declared noise rejection capability.

8 Additional features

8.1 Loudspeaking and hand-free facilities

For further study. These features shall follow the relevant (I)-ETS when this is available.

8.2 Tandem with mobile radio network

A tandem of DECT with a mobile radio network shall provide a radio link between the DECT FP and a network, e.g. the PSTN/ISDN.

A speech path shall be provided by connecting a PCM 0dB reference point at the line side of the RFP, with a PCM 0dB speech reference point of a mobile radio transceiver.

For tandeming with analogue mobile communication networks, national planning rules shall be applied. Tandeming with GSM is specified in 8.2.1 (below).

8.2.1 Tandem with GSM

The FP (see figure 3) is interfaced via its uniform PCM interface point to the 0dB PCM X-interface point of a GSM mobile radio. See figure 6.

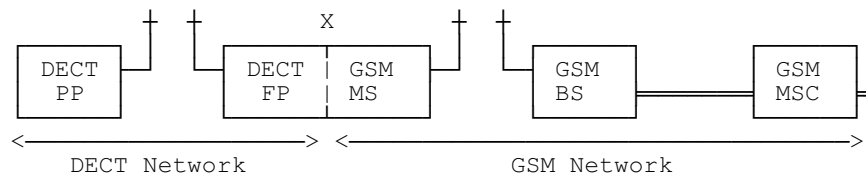

Figure 6: DECT in tandem with the GSM mobile network

8.2.1.1 Network echo control

The network echo control devices inserted in the FP to meet the extra echo loss requirements of subclause 7.10 are not required for tandem connections with GSM. If they are implemented in the FP, they shall be disabled.

NOTE: The echo from the GSM network is controlled by the Mobile Switching Centre (MSC) echo canceller in the GSM fixed network, as stated in ETS 300 540 [23] (GSM 03.50).

8.2.1.2 Terminal coupling loss

There are two cases depending upon the mode of the GSM mobile transmitter operation. The mode may change from call to call.

8.2.1.3 The GSM mobile transmitter operates in continuous mode

An echo device shall be implemented at the FP or the GSM side of the PCM reference point. It shall meet the requirements of subclause 7.4.1.2 b). If the PP has $TCL_w = 46$ dB, the echo device shall be disabled.

8.2.1.4 The GSM mobile transmitter operates in discontinuous mode, DTX

The echo device described in subclause 7.4.1.2 shall be disabled.

The GSM mobile transmitter shall not be activated (double-talk state) by a sending speech signal with a level of less than 30 dB below the receiving speech level.

NOTE: The mobile combination of a DECT FP and a GSM mobile is a specially designed unit. This unit shall meet the 30 dB requirement irrespectively of whether the GSM DTX design itself meets this requirement or not. See annex C for information on GSM, DTX.

8.3 DECT connected to the GSM fixed network

In this application DECT provides a base station sub-system, BSS, to the GSM network. Neither the GSM radio link nor the GSM codec is involved.

The FP, figure 3, is interfaced via its uniform PCM interface point to the 0dB PCM A-interface point of a GSM Network (MSC). See figure 7.

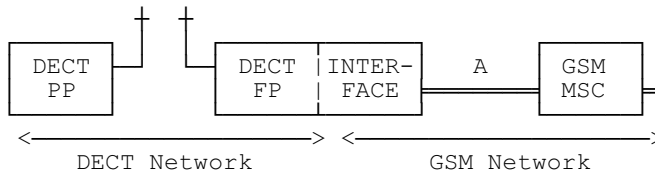

Figure 7: DECT in tandem with the GSM fixed network

8.3.1 Network echo control

The network echo devices inserted in the FP to meet the extra echo loss requirements of subclause 7.10 are not required for tandem connections with GSM. If they are implemented in the FP they shall be disabled.

NOTE: The echo from the GSM network is controlled by the Mobile Switching Centre (MSC) echo canceller in the GSM fixed network, as stated in ETS 300 540 [23] (GSM 03.50).

8.3.2 Terminal coupling loss

An echo device shall be implemented at the FP or the GSM side of the PCM reference point. It shall meet the requirements of subclause 7.4.1.2 b). The echo device may be disabled in accordance with optionally available routing information. If the PP has $TCLw = 46$ dB, the echo device shall be disabled.

8.4 Wireless Relay Stations (WRS)

The connection between the FT and the WRS is wireless via the closest RFP. A WRS is locked to the closest RFP, or closest WRS when cascading WRSs is allowed. An RFP and a WRS, appear equal to a PP. See figure 8.

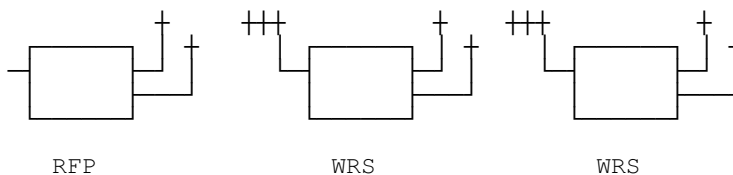

NOTE 1: A WRS is locked to the closest RFP, or closest WRS when cascaded WRSs are allowed. An RFP and WRS, appear equal to a PP.

Figure 8: FT connection to WRSs

Due to the wireless link, a PP connection to a WRS introduces an incremental delay in relation to a connection to an RFP. The incremental average 1-way delay for speech is 5 ms per cascaded CRFP and maximum 2,5 ms for any chain of cascaded REPs.

This incremental delay causes no fundamental limitation for the speech services.

The DECT speech quality requirements are met with the general DECT echo control requirements for the cases : one CRFP link and any chain of cascaded REP links.

NOTE 2: Compared to an RFP, a WRS may introduce capacity restrictions and higher blocking rate to the services offered. The restrictions may increase with the number of cascaded WRS links, especially for REPs. This will in practice limit a REP chain to three links.

When 2 or 3 CRFP links are cascaded, the FP network echo control requirements subclause 7.10 may need to be modified depending on the characteristics of the specific network to which the FP is connected. See below.

NOTE 3: FP approval according to modified network echo control requirements may be made in agreement with national authorities.

8.4.1 Modified FP network echo control requirements for implementation of 2 and 3 CRFP links in cascade

These modifications refer to Requirement 1 and Requirement 2 of subclause 7.10.

Number of cascaded CRFP links:	2	3
Req. 1- 0-4 ms TELR:	>27 dB	>29 dB
Req. 2- 4-70 ms Extra echo loss:	>11 dB	>12 dB

NOTE 1: Requirement 1 does not apply when the FP has a 4-wire through connection to the PSTN/ISDN. Nor do the requirements 1 or 2 apply when the FP is connected to a GSM network, because the corresponding echo control function shall be disabled if implemented. See subclauses 8.2.1.1 and 8.3.1.

NOTE 2: A general solution for the modified Requirements 1 and 2 is to apply an echo canceller for TELR 29 dB and 0-70 ms control range

Annex A (informative): Description of "reference" echo control devices

This annex describes reference echo control devices based upon concepts that are as simple as possible but include a sufficient number of features to give guidance for a wide range of possible implementations. The use of the term "reference" denotes an implementation given for guidance and illustration only. It does not exclude other implementations nor does it imply that the described devices are necessarily the most appropriate realization on any technical, operational or economic grounds. See CCITT Recommendation G.165 [13].

A.1 Handset echo

A.1.1 Overview

A.1.1.1 Connection to the PSTN/ISDN

FPs with 4-wire connection should provide the artificial echo specified in subclause 7.4.1.2 a). It should be disabled if the PP meets the requirements of subclause 7.4.1.1 a), $TCLw > 46$ dB, and may be disabled on available call routing information.

The combined handset and hybrid echo from analogue telephones is considerably higher than the DECT 34 dB $TCLw$ echo. Therefore the international planning rules demand provision of echo control devices in the public network, if the one-way network echo delay exceeds 25 ms. See CCITT Recommendation G.131 [11], Rule M.

A.1.1.1.1 Local and national calls

The 34 dB $TCLw$ for a DECT system will give a $OLR_{ECHO} = TELR$ of about 44 dB. This will meet the echo requirements with good margin for connections with one-way delay (excluding DECT) less than 25 ms. See the 1 % curve of figure 2 in CCITT Recommendation G.131 [11]. The requirement is met for DECT systems at both ends of the connection also with a DECT tethered local loop replacement in the public network.

A.1.1.1.2 Long distance connections with echo control devices in the PSTN/ISDN, e.g. calls via satellites

Echo control devices are provided in the public network for connections with more than 25 ms one-way network delay. Older devices are of echo suppressor type CCITT Recommendation G.164 [12]. Most used are echo cancellers CCITT Recommendation G.165 [13].

These devices are designed to eliminate echoes from analogue telephones when the one-way delay of the national network is less than 12 ms. Late design of echo cancellers allow about 30 ms one-way delay.

However, as long as these devices are active, they will also eliminate the DECT acoustic echo. The 34 dB attenuated echo is low enough not to be detected as break-in speech during single talk condition during speech from the far-end. The DECT echo will therefore be eliminated by an echo suppressor or by the Non-Linear Processor (centre clipper), NLP, or an echo canceller, whichever device is used. Both the suppressor and the NLP have hangover times which will prevent the delayed DECT echo to be heard even at the end of a speech sentence.

The artificial echo, subclause 7.4.1.2 option a) simulates the echo from a very good analog 2-wire telephone. When an echo canceller is used in the network, the artificial echo loss path provides an echo, that is guaranteed in-range for the linear echo estimation process. This will ensure that the echo canceller and its NLP is active. The artificial echo is principally not needed to keep echo suppressors nor all types of echo cancellers active, but it does not hurt either.

A.1.1.2 Connection to the GSM network

When a DECT system is connected in tandem with a GSM mobile network, subclause 8.2.1, or a GSM fixed network, subclause 8.3 the FP provides the echo control function specified in subclause 7.4.1.2 b). It should be disabled if the PP meets the requirements of subclause 7.4.1.1 a), $TCL_w > 46$ dB, and for the case of Discontinuous, DTX, specified in subclause 8.2.1.4.

Echo control function specified in subclause 7.10 should be disabled.

A.1.2 Implementation of the FP echo control function subclause 7.4.1.2 b

The needed extra echo loss can preferably be implemented by using a Non-Linear Processor, NLP, that, when active, clips all sending signals lower than the suppression threshold. See figure A.1.

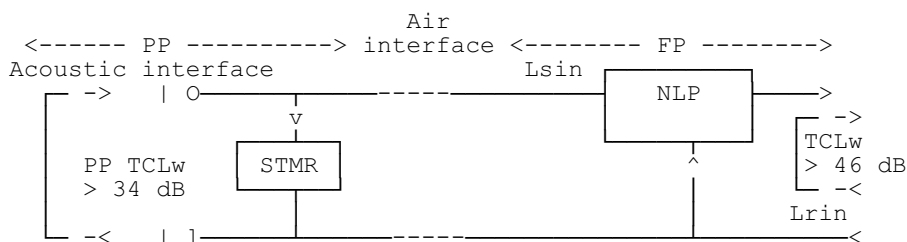

Figure A.1: Implementation of the handset echo control

Such a NLP is described in CCITT Recommendation G.165 [13], annex C. Two variants are included, both based on an analogue centre clipper having the transfer function illustrated in figure A.2.

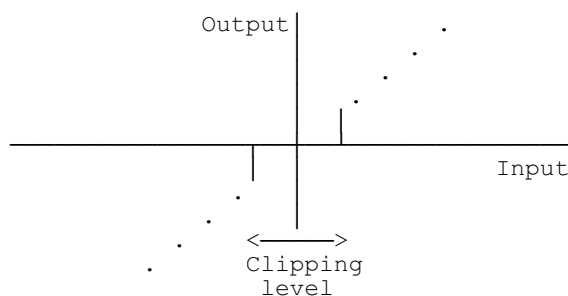

Figure A.2: Transfer function of non-linear processor

In the first case the suppression threshold level is adaptive, adaptation being by reference to L_{rin} . In the second variant the suppression level is fixed.

A.1.2.1 Suppression threshold

The value of the suppression threshold depends on the handset acoustic TCL, below called PTCL:

- Fixed: $V_{sup} = (- PTCL) \text{ dBm}_0$;
- Adaptive: $V_{sup} = (L_{rin} - PTCL + 6) \text{ dBm}_0$.

6 dB is the operation margin that prevents the possible ambient noise to pass through the activated NLP. If the noise is high enough to pass through, it will also be high enough to mask the echo.

PTCL is > 34 dB.

If for example PTCL is set to 30 dB; then

- $V_{sup} = - 30 \text{ dBm}_0$; or
- $V_{sup} = L_{rin} - 24 \text{ dB}$.

A.1.2.2 Static characteristics of activation control

In CCITT Recommendation G.165 [13], annex C, the activation control is defined by reference to L_{rin} . The NLP is active when the level of signal in the sending direction L_{sin} is lower than the activation threshold V_{act} :

Fixed: $V_{act} = (L_{rin} - 6) \text{ dBm0}$;
 Adaptive: $V_{act} = (L_{rin} - PTCL + 6) \text{ dBm0}$.

As we are dealing here with acoustic echo in a terminal equipment instead of electric echo in the network, a simplification seems reasonable and V_{act} can be fixed:

$V_{act} = -31 \text{ dBm0}$.

A.1.2.3 Dynamic characteristics of activation control

Table A.1: Non-linear processor hangover times

Switch from	Vsup variant	Recommended values
active to inactive	fixed	15 - 64 ms
	adaptive	2 ms (echo path delay)
inactive to active	fixed	20 - 120 ms
	adaptive	30 - 50 ms

A.2 Network echo

The requirement on network echo control (see subclause 7.10) can be met with the following implementation, depending on the type of line interface:

- 1) for 4-wire interface, a soft suppressor (figure A.3);
- 2) for 2-wire interface, a soft suppressor and an echo canceller (figure A.4).

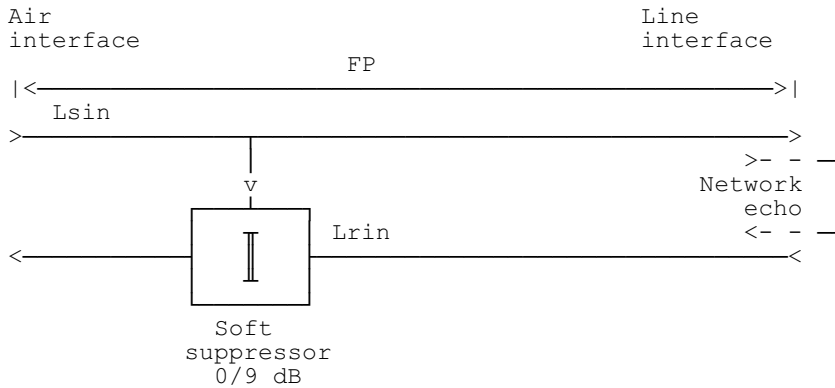

Figure A.3: Implementation of the network echo control 4-wire line interface

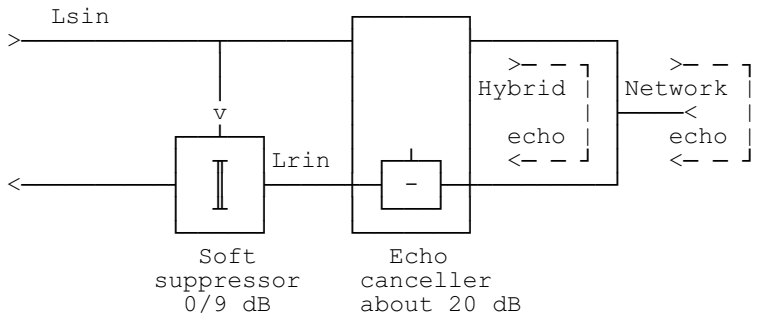

Figure A.4: Implementation of the network echo control 2-wire line interface

A.2.1 Soft suppressor implementation of requirement 2 of subclause 7.10

A 9 dB soft echo suppressor meets the whole requirement for 4-wire connection and a part of the requirement for the 2-wire connection. The principle of operation is similar to the one described in CCITT Recommendation G.164 [12]. Therefore the same operational parameters can be used.

The 9 - 12 dB loss for requirement 2 is intended to cover different foreseen connection cases. It is also a compromise between reduction of echoes from badly matched far-end national hybrids, and low noise contrast requirements.

In most applications the majority of calls will not need any extra echo suppression, and therefore optimization should be made to minimize the noise contrast. Thus the lower 9 dB value is recommended.

The 9 - 12 dB loss is required when no routing information is available. When suitable routing information is available, the operator is allowed to disconnect or reduce the loss below 9 dB to optimize it for specific connections or applications.

This parameter of requirement 2 only effects the DECT user and not the general network planning rules.

A.2.1.1 Static characteristics

The echo suppressor is active if the speech level in the sending direction L_{sin} is greater than the suppression threshold:

- $V_{sup} = -31$ dBm0.

The suppressor becomes inactive if the speech level falls under the release threshold:

- $V_{rel} = V_{sup} (+0$ dB, -3 dB).

A.2.1.2 Dynamic characteristics

The switching characteristics are taken from CCITT Recommendation P.34 [18], that relates to terminal equipment and seems more appropriate than CCITT Recommendation G.164 [12], that relates to network echo suppressor ($T_r \leq 2$ ms and $T_h = 24$ to 36 ms).

- 1) Build-up time: $T_r < 15$ ms, preferably < 10 ms.
- 2) Hang-over time: $T_h > 100$ ms, preferably between 150 and 250 ms.

The soft suppressor may pass a 6 dB state at the switch on and switch off of the 9 - 12 dB attenuation. The 6 dB state should be of less than 15 ms duration.

A.2.2 Additional echo control for a 2-wire interface of requirement 1 of subclause 7.10

For the 2-wire case a Talker's Echo Loudness Rating (TELR) of 24 dB is required for the delayed sidetone from the FP's 2-wire interface. This can be performed in some cases by hybrid matching, or more generally by means of an echo canceller.

In order to meet the requirement of $TELR = 24$ dB for the range of line impedances specified by the national authority, around 20 dB extra loss is estimated to be required for the worst cases of mismatch. This implies that for normal cases when, $TELR > 30$ dB is expected for the delayed sidetone.

$TELR = 24$ dB equates to $LE = 14$ dB at the PCM reference point of the FP.

NOTE: The solution using an adaptive soft suppressor with up to 20 dB attenuation is not now recommended.

Such an echo canceller should be rather simple to implement since the control range is limited to 4 ms. But it is peculiar in the sense that the near-end echo may be equal or even higher than the far-end signal.

The echo canceller is operating on the uniform PCM speech signals. It makes a linear estimate A_{echo} of the echo path A_{echo} (see figure A.5), and subtracts this estimate at the subtractor. The residual echo level after the subtractor is L_{res} . L_{fes} is the level of the far-end speech.

$$\begin{aligned} L_{\text{res}} &= L_{\text{sin}} - A_{\text{echo}} - A_{\text{canc}} \quad (\text{in power}); \\ L_{\text{rout}} &= L_{\text{res}} + L_{\text{fes}} \end{aligned}$$

Since the worst case A_{echo} is -1 dB, the required A_{canc} is about 15 - A dB. Therefore no NLP is needed to further reduce L_{rout} . A is the attenuation of the soft suppressor for requirement 2. If the soft suppressor can be disabled (e.g. for local PABX calls), A is set to zero during type approval testing I-ETS 300 176 [9].

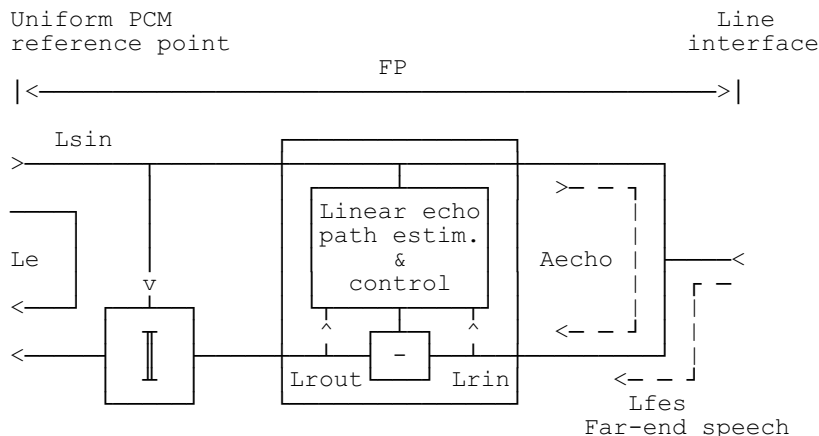

Figure A.5: Echo canceller implementation

Speech detection for e.g. double talk, cannot be made before the subtractor (L_{rin}), as in CCITT Recommendation G.165 [13], because the level of the hybrid echo can be larger than the level of the far-end signal.

Detection of the far-end speech has to be made after the subtractor (L_{rout}), and detection is only possible when the near end echo is cancelled to a certain degree.

Thus at the start (adaptation coefficients = 0), the FES detector is switched off. It is switched on once L_{rout} is below a certain threshold. This will only happen when L_{fes} is very low and the filter adaptation is satisfying (L_{res} low).

At detected double talk, the adaptation cannot be completely switched off, but the adaptation speed should be reduced by a factor of e.g. 4. This allows adaptation during conversation if the echo path suddenly is changed.

A.2.3 Echo canceller used for both requirements 1 and 2

An alternative to implementing a soft suppressor, is to use an echo canceller as described in subclause A.2.2 with the control range prolonged to 70 ms. This solution may be more expensive, but will give better performance for PP reception on a noisy connection.

Annex B (informative): Local loop application

This annex relates to public local loop applications.

A PP is a physical grouping that contains all elements between the user and the DECT air interface. A PP is a generic term that may describe one or several physical pieces.

A PP is logically divided into one PT plus zero or more Terminal Adaptors (TA) plus one or more End Systems (ESs).

The ES can thus be implemented in a handset, or be e.g. a standard ISDN terminal, a standard 2-wire telephone or even a cordless telephone system, tethered to a TA via a standard subscriber's telephone socket.

Below, guidance is given for the case when the ES is connected via a standard 2-wire socket, e.g. in a public local loop evolutionary application.

B.1 DECT tethered local loop replacement with 2-wire PP end system

Below we consider the case when a public operator uses DECT for a local loop replacement.

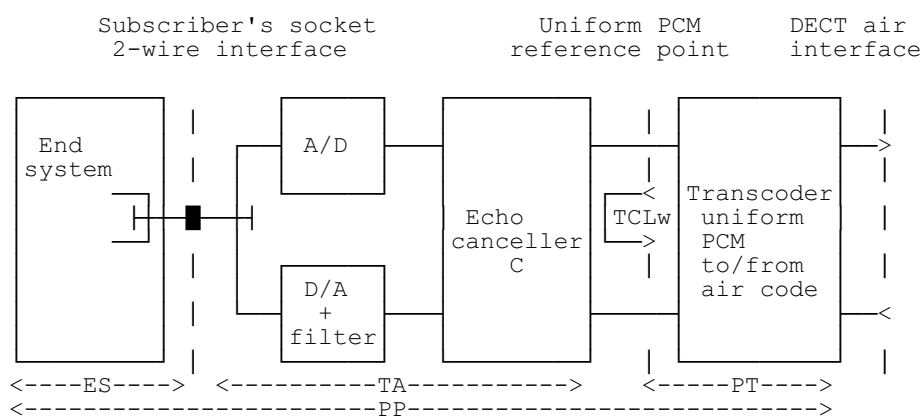

Figure B.1: PP in tethered local loop application

B.1.1 TCLw requirements

If the public operator plans the control range of his echo cancellers at the international gateways to include the hybrids at the subscriber's socket interface and a standard telephone end system, then no extra echo canceller C is needed.

If the hybrids in figure B.1 are outside the control range of the echo cancellers at the international gateways, then the hybrid's echo return loss LE has to be > 34 dB. If this is not met, an echo canceller C, with about 20 dB extra echo attenuation and with a 4 ms control range, of the same type as described in A.2.2 (without the soft suppressor) is needed in the PP TA.

The echo control device may in principle for some installation cases, alternatively be implemented at the FP with a control range of 20 to 28 ms (or more if Wireless Base Stations (WBSs) are implemented). At the FP some trunking gain can be provided on needed number of simultaneous echo control functions.

If the ES has higher loop delay than a standard telephone (2 ms), e.g. a residential DECT system, this system has to meet the normal TCLw requirements of subclause 7.4.1.1. See annex A, subclauses A.1.1.1.1 and A.1.1.1.2.

B.1.2 Network echo

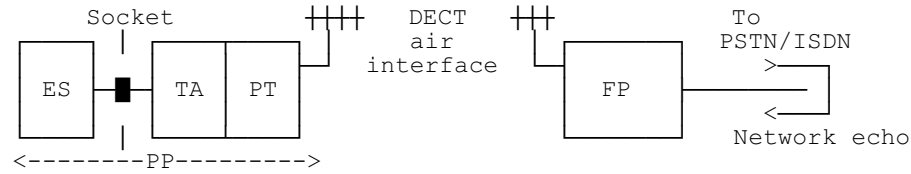

Figure B.2: DECT local loop replacement

The FP of figure B.2 has to meet the normal echo control requirements 1 and 2 of subclause 7.10.

If the ES is a (residential) DECT system, each FP will meet the requirement of subclause 7.11 and take care of its own network echo.

It is however recommended that requirement 2 is realized with an echo canceller, or a soft suppressor with reduced echo loss if the operator has a modern network, see annex A, subclause A.2.1.

This recommendation is to minimize the noise contrast for the case when the ES is a DECT residential system, also implementing requirement 2.

It is allowed to disconnect or reduce requirement 2, when suitable routing information is available. This may be the case for FPs under control of one operator in a local loop application. For instance, if an operator has a modern network where the far-end hybrids have $LE > 20$ dB, a reduction to 6 dB could be suitable if the loss in the FP in figure B.2 is implemented as a soft suppressor and not as an echo canceller.

B.2 Quantization distortion considerations

The number of Quantization Distortion Units (QDUs) accumulated by a connection could potentially exceed the recommended limits for transmission planning, see ETR 041. A 32 kbit/s ADPCM codec introduces about 3 QDUs.

If analogue 2-wire connections are provided in the customers premises, the operator has the options to choose a 32 kbit/s ADPCM bearer or a 64 kbit/s PCM bearer in the DECT local loop link. Choosing the 32 kbit/s ADPCM bearer is more frequency efficient, choosing a 64 kbit/s PCM bearer avoids the potential risk of adding QDUs from two ADPCM codecs when the customer uses a DECT system in his premises.

If only digital 4-wire connections are provided in the customers premises the DECT FP of the customer will incorporate synchronous coding adjustment. Hence the second ADPCM codec on the DECT local loop link will not introduce any additional QDUs. Synchronous coding adjustment should also be implemented in the local loop link if further ADPCM stages are used in the national network.

Annex C (informative): GSM Discontinuous Transmission (DTX), and Voice Activity Detection (VAD)

Discontinuous Transmission (DTX) and Voice Activity Detection (VAD) are mandatory features in a GSM mobile, but not in a GSM base station. A GSM mobile has to be able to operate in both modes.

Without DTX and VAD in the up-link, TCL 34 dB and NLP in the FP meet the requirements.

If VAD and DTX is implemented the DECT TCL echo path is broken except for double talk. At double talk TCL 34 dB should be enough, since the echo level will be 34 dB below the (annoying) double talk and is masked by the double talk. Furthermore double talk occupies only a small fraction of the speech time.

The 34 dB attenuated echo is not interpreted as a speech break-in signal. When DTX is implemented, the normal background speech or music in a public environment should not eliminate the DTX function. For example, in CCITT Recommendations G.164 [12] and G.165 [13] double talk state occurs only if the "sending speech" level is higher than the "receiving speech" level - 6 dB.

The VAD is extracting noise parameters in speech pauses in the signal from the microphone (sending speech). The VAD might need to detect speech pauses at 40 - 45 dBmO levels, in order to deliver clean noise parameters to the GSM base station, for noise insertion in DTX pauses. But these low levels need not be related to levels required to prevent background speech or an acoustic echo to eliminate the DTX function. The VAD is specially designed for traffic and motor noise in a car, and not optimized for an environment with background speech and music.

Therefore it is stated in subclause 8.2.1.2 "that the GSM mobile transmitter shall not be activated (double-talk state) by a sending speech signal with a level of less than 30 dB below receiving speech level". If CCITT Recommendations G.164 [12] and G.165 [13] are used as guidance for an upper level, a threshold may be implemented somewhere in the range - 6 dB to - 30 dB below the level of the speech received from the far-end.

Annex D (informative): Speech levels in relation to ambient room noise and examples of adaptive volume control settings

When room noise is present a higher received speech signal level (lower RLR_H) is required to give the best possible receiving speech quality and intelligibility. The increase in the receiving level is a function of increasing room noise level.

When room noise is present people raise their voice level (talk louder) and the sending speech level will be higher than the optimum level. By decreasing the sending sensitivity (higher SLR_H) the sending level to the line will be around optimum and at the same time the absolute level of the transmitted noise will decrease.

The increase in receiving sensitivity and the decrease in sending sensitivity is approximately linearly related to increasing room noise level. For every dB increase in room noise level there is a corresponding increase in receiver sensitivity and decrease in sending sensitivity of about 0,5 dB.

Table D.1 presents - for guidance and illustration only - three examples of volume control characteristics.

Table D.1: Examples of FP adaptive volume control

	Ambient noise	Volume variation receiving (sending)
Single threshold	between 50 and 55 dBA	8 dB gain (attenuation)
Double threshold	50 dBA 60 dBA	5 dB gain (attenuation) 10 dB gain (attenuation)
Continuous variation	from 30 to 50 dBA from 50 to 70 dBA	3 dB increase (decrease) 8 dB increase (decrease)

Annex E (informative): Bibliography

- ETR 043: "Radio Systems and Equipment (RES); Digital European Cordless Telecommunications (DECT); Common interface; Services and facilities requirements specification".
- ETR 015: "Radio Systems and Equipment (RES); Digital European Cordless Telecommunications (DECT); Reference document".

ETR 056: "Radio Systems and Equipment (RES); Digital European Cordless Telecommunications (DECT); System description document".
- ETR 042: "Radio Systems and Equipment (RES); Digital European Cordless Telecommunications (DECT); A guide to DECT features that influence the traffic capacity and the maintenance of high radio link transmission quality, including the results of simulations".
- ETR 041: "Transmission Multiplexing (TM); Digital European Cordless Telecommunications (DECT); Transmission aspects 3,1 kHz telephony, interworking with other networks".

History

Document history	
October 1992	First Edition
August 1995	Public Enquiry PE 90: 1995-08-21 to 1995-12-15
June 1996	Vote V 106: 1996-06-24 to 1996-08-30
September 1996	Second Edition