



**E**UROPEAN  
**T**ELECOMMUNICATION  
**S**TANDARD

**ETS 300 175-2**

September 1996

Second Edition

---

Source: ETSI TC-RES

Reference: RE/RES-03027-2

ICS: 33.060, 33.060.50

**Key words:** DECT, radio

**Radio Equipment and Systems (RES);  
Digital Enhanced Cordless Telecommunications (DECT);  
Common Interface (CI);  
Part 2: Physical layer (PHL)**

**ETSI**

European Telecommunications Standards Institute

**ETSI Secretariat**

**Postal address:** F-06921 Sophia Antipolis CEDEX - FRANCE

**Office address:** 650 Route des Lucioles - Sophia Antipolis - Valbonne - FRANCE

**X.400:** c=fr, a=atlas, p=etsi, s=secretariat - **Internet:** secretariat@etsi.fr

Tel.: +33 92 94 42 00 - Fax: +33 93 65 47 16

---

**Copyright Notification:** No part may be reproduced except as authorized by written permission. The copyright and the foregoing restriction extend to reproduction in all media.

© European Telecommunications Standards Institute 1996. All rights reserved.



## Contents

Foreword .....		7
1	Scope .....	9
2	Normative references .....	9
3	Definitions and abbreviations .....	10
3.1	Definitions .....	10
3.2	Abbreviations .....	11
4	PHL services .....	12
4.1	RF channels (access in frequency) .....	12
4.1.1	Nominal position of RF carriers .....	12
4.1.2	Accuracy and stability of RF carriers .....	13
4.2	Time Division Multiple Access (TDMA) structure (access in time) .....	13
4.2.1	Frame, full-slot, double-slot, and half-slot structure .....	13
4.2.2	Reference timer accuracy and stability .....	14
4.2.3	RFP transmission jitter .....	14
4.2.4	PP reference timer synchronization .....	15
4.2.5	System synchronization .....	15
4.2.6	Inter-system synchronization .....	15
4.2.7	Reference timer adjustment for synchronization .....	15
4.3	Cells (access in space) .....	16
4.4	Physical packets .....	16
4.4.1	The short physical packet P00 .....	16
4.4.2	The basic physical packet P32 .....	17
4.4.3	The low capacity physical packet P08j .....	17
4.4.4	The high capacity physical packet P80 .....	18
4.5	Physical channels .....	18
4.5.1	Ra(K, L, M, N) notation .....	18
4.5.2	The short physical channel R00(K,L,M,N) .....	19
4.5.3	The basic physical channel R32(K,L,M,N) .....	19
4.5.4	The low-rate physical channel R08j(K,L,M,N) .....	20
4.5.5	The high capacity physical channel R80(K,L,M,N) .....	20
4.6	Synchronization field S .....	21
4.7	D-field .....	21
4.7.1	Physical packet P00 .....	21
4.7.2	Physical packet P32 .....	22
4.7.3	Physical packet P08j .....	22
4.7.4	Physical packet P80 .....	22
4.8	Z-field .....	22
4.9	Bit pattern during ramping .....	23
5	Transmission of physical packets .....	23
5.1	Definitions .....	23
5.1.1	End of the physical packet .....	23
5.1.2	Transmitted power .....	23
5.1.3	Normal Transmitted Power (NTP) .....	23
5.2	Transmission burst .....	23
5.2.1	Transmitter attack time .....	23
5.2.2	Transmitter release time .....	24
5.2.3	Minimum power .....	24
5.2.4	Maximum power .....	24
5.2.5	Maintenance of transmission after packet end .....	24
5.2.6	Transmitter idle power output .....	24
5.3	Transmitted power .....	25
5.3.1	Peak power per transceiver .....	25

	5.3.1.1	PP and RFP with an integral antenna .....	25
	5.3.1.2	PP and RFP with external connections for all antennas .....	25
	5.3.2	Maximum EIRP and number of transceivers .....	25
5.4		RF carrier modulation .....	25
	5.4.1	Modulation method .....	25
	5.4.2	Definition of "1" and "0" .....	25
	5.4.3	Deviation limits .....	25
5.5		Unwanted RF power radiation .....	26
	5.5.1	Emissions due to modulation .....	26
	5.5.2	Emissions due to transmitter transients .....	27
	5.5.3	Emissions due to intermodulation .....	27
	5.5.4	Spurious emissions when allocated a transmit channel .....	27
6		Reception of physical packets .....	28
6.1		Definitions and conditions for clause 6 .....	28
	6.1.1	Power levels and field strength .....	28
	6.1.2	Test conditions .....	28
	6.1.3	Reference DECT radio end point .....	28
6.2		Radio receiver sensitivity .....	28
6.3		Radio receiver reference bit error rate .....	29
6.4		Radio receiver interference performance .....	29
6.5		Radio receiver blocking .....	29
	6.5.1	Owing to signals occurring at the same time but on other frequencies .....	29
	6.5.2	Owing to signals occurring at a different time .....	30
6.6		Receiver intermodulation performance .....	30
6.7		Spurious emissions when not allocated a transmit channel .....	30
	6.7.1	Out of band .....	30
	6.7.2	In the DECT band .....	30
7		Primitives between physical layer and other entities .....	30
7.1		Medium access control layer (D-SAP) .....	30
	7.1.1	PL_TX {req} .....	31
	7.1.2	PL_RX {req,cfm} .....	31
	7.1.3	PL_FREQ_ADJ {req,} .....	32
7.2		Management entity (PM-SAP) .....	32
	7.2.1	PL_ME_SYNC {req,cfm} .....	32
	7.2.2	PL_ME_SIG_STR {req,cfm} .....	33
	7.2.3	PL_ME_TIME_ADJ {req,cfm} .....	33
8		PHL procedures .....	33
8.1		Addition of synchronization field and transmission .....	33
8.2		Packet reception and removal of synchronization field .....	33
8.3		Measurement of signal strength .....	34
8.4		Synchronization pulse detection .....	34
8.5		Timing adjustment .....	34
8.6		Frequency adjustment .....	34
9		Management entity procedures related to PHL .....	34
9.1		List of quietest physical channels .....	35
9.2		Physical channels with greatest field strength (PP only) .....	35
9.3		Extract timing .....	35
Annex A (normative):		Safety requirements .....	36
A.1		Recommendation .....	36
A.2		Safety distances .....	36
Annex B (informative):		Public Access Profile (PAP): mandatory requirements regarding the physical layer .....	37
B.1		Minimum Normal Transmit Power (NTP) .....	37

B.2	Radio receiver sensitivity.....	37
B.3	Z-field .....	37
B.4	Sliding collision detection .....	37
Annex C (normative):	Synchronization Port.....	38
C.1	Synchronization Ports .....	38
C.1.1	External synchronization output port .....	38
C.1.2	External synchronization input port .....	38
C.2	Synchronization.....	39
C.2.1	External synchronization signal .....	40
C.2.2	Envelope synchronization.....	40
C.3	Interconnection cable.....	41
C.4	Propagation delay of synchronization signals .....	41
C.4.1	Calculation of Propagation delay (informative).....	41
C.4.2	Delay compensation .....	42
C.5	Synchronization by a GPS receiver. ....	42
C.5.1	DECT multiframe time synchronization using GPS .....	42
C.5.2	DECT multiframe-number synchronization using GPS .....	43
C.5.3	DECT PSCN synchronization using GPS .....	43
Annex D (normative):	Prolonged preamble .....	44
D.1	Bit pattern .....	44
D.2	The power-time template .....	44
D.3	Procedures for implementing a prolonged preamble .....	44
D.4	Procedures for implementing a switched receiver antenna diversity algorithm relying on a prolonged preamble .....	45
Annex E (informative):	Bibliography.....	46
History.....		47

Blank page

## Foreword

This second edition European Telecommunication Standard (ETS) has been produced by the Radio Equipment and Systems (RES) Technical Committee of the European Telecommunications Standards Institute (ETSI).

This ETS forms part 2 of a series of 9 laying down the arrangements for the Digital Enhanced Cordless Telecommunications (DECT) Common Interface (CI).

Part 1: "Overview".

**Part 2 "Physical layer (PHL)".**

Part 3 "Medium Access Control (MAC) layer".

Part 4 "Data Link Control (DLC) layer".

Part 5: "Network (NWK) layer".

Part 6: "Identities and addressing".

Part 7: "Security features".

Part 8: "Speech coding and transmission".

Part 9: "Public Access Profile (PAP)".

Annexes A, C and D to this ETS are normative. Annex B and E to this ETS are informative.

Further details of the DECT system may be found in ETR 015, ETR 043, and ETR 056.

<b>Transposition dates</b>	
Date of adoption of this ETS:	6 September 1996
Date of latest announcement of this ETS (doa):	31 December 1996
Date of latest publication of new National Standard or endorsement of this ETS (dop/e):	30 June 1997
Date of withdrawal of any conflicting National Standard (dow):	30 June 1997

Blank page



## 1 Scope

This second edition European Telecommunication Standard (ETS) gives an introduction and overview of the complete Digital Enhanced Cordless Telecommunications (DECT) Common Interface (CI).

This part of the DECT CI specifies the physical channel arrangements. DECT physical channels are radio communication paths between two radio end points. A radio end point is either part of the fixed infrastructure or a Portable Part (PP), typically a handset. The assignment of one or more particular physical channels to a call is the task of higher layers.

The Physical Layer (PHL) interfaces with the Medium Access Control (MAC) layer, and with the Lower Layer Management Entity (LLME). On the other side of the PHL is the radio transmission medium which has to be shared extensively with other DECT users and a wide variety of other radio services. The tasks of the PHL can be grouped into five categories:

- a) to modulate and demodulate radio carriers with a bit stream of a defined rate to create a radio frequency channel;
- b) to acquire and maintain bit and slot synchronization between transmitters and receivers;
- c) to transmit or receive a defined number of bits at a requested time and on a particular frequency;
- d) to add and remove the synchronization field and the Z-field used for rear end collision detection;
- e) to observe the radio environment to report signal strengths.

## 2 Normative references

This ETS incorporates, by dated or undated reference, provisions from other publications. These normative references are cited at the appropriate places in the text and the publications are listed hereafter. For dated references, subsequent amendments to, or revisions of, any of these publications apply to this ETS only when incorporated in it by amendment or revision. For undated references the latest edition of the publication referred to applies.

- [1] ETS 300 175-1 (1996): "Radio Equipment and Systems (RES); Digital Enhanced Cordless Telecommunications (DECT); Common Interface (CI); Part 1: Overview".
- [2] ETS 300 175-3 (1996): "Radio Equipment and Systems (RES); Digital Enhanced Cordless Telecommunications (DECT); Common Interface (CI); Part 3: Medium Access Control (MAC) layer".
- [3] ETS 300 175-4 (1996): "Radio Equipment and Systems (RES); Digital Enhanced Cordless Telecommunications (DECT); Common Interface (CI); Part 4: Data Link Control (DLC) layer".
- [4] ETS 300 175-5 (1996): "Radio Equipment and Systems (RES); Digital Enhanced Cordless Telecommunications (DECT); Common Interface (CI); Part 5: Network (NWK) layer".
- [5] ETS 300 175-6 (1996): "Radio Equipment and Systems (RES); Digital Enhanced Cordless Telecommunications (DECT); Common Interface (CI); Part 6: Identities and addressing".
- [6] ETS 300 175-7 (1996): "Radio Equipment and Systems (RES); Digital Enhanced Cordless Telecommunications (DECT); Common Interface (CI); Part 7: Security features".
- [7] ETS 300 175-8 (1996): "Radio Equipment and Systems (RES); Digital Enhanced Cordless Telecommunications (DECT); Common Interface (CI); Part 8: Speech coding and transmission".

- [8] ETS 300 175-9 (1996): "Radio Equipment and Systems (RES); Digital Enhanced Cordless Telecommunications (DECT); Common Interface (CI); Part 9: Public Access Profile (PAP)".
- [9] ETS 300 444: "Radio Equipment and Systems (RES); Digital European Cordless Telecommunications (DECT); Generic Access Profile (GAP)".
- [10] I-ETS 300 176: "Radio Equipment and Systems (RES); Digital European Cordless Telecommunications (DECT); Approval test specification".

### 3 Definitions and abbreviations

#### 3.1 Definitions

For the purposes of this ETS the following definitions apply:

**antenna diversity:** See ETS 300 175-1 [1].

**cell:** See ETS 300 175-1 [1].

**Central Control Fixed Part (CCFP):** See ETS 300 175-1 [1].

**channel:** See ETS 300 175-1 [1].

**cluster:** See ETS 300 175-1 [1].

**Connection Oriented mode (C/O):** See ETS 300 175-1 [1].

**Cordless Radio Fixed Part (CRFP):** See ETS 300 175-1 [1].

**coverage area:** See ETS 300 175-1 [1].

**Dect Network (DNW):** See ETS 300 175-1 [1].

**double duplex bearer:** See ETS 300 175-1 [1].

**double simplex bearer:** See ETS 300 175-1 [1].

**double slot:** One 12th of a TDMA frame which is used to support one high capacity physical channel.

**down-link:** See ETS 300 175-1 [1].

**duplex bearer:** See ETS 300 175-1 [1].

**Fixed Part (DECT Fixed Part) (FP):** See ETS 300 175-1 [1].

**Fixed Radio Termination (FT):** See ETS 300 175-1 [1].

**frame:** See ETS 300 175-1 [1].

**full slot (slot):** See ETS 300 175-1 [1].

**guard space:** See ETS 300 175-1 [1].

**half slot:** See ETS 300 175-1 [1].

**handover:** See ETS 300 175-1 [1].

**intercell handover:** See ETS 300 175-1 [1].

**intracell handover:** See ETS 300 175-1 [1].

**Lower Layer Management Entity (LLME):** See ETS 300 175-1 [1].

**multiframe:** See ETS 300 175-1 [1].

**physical channel (channel):** See ETS 300 175-1 [1].

**Portable Part (DECT Portable Part) (PP):** See ETS 300 175-1 [1].

**Portable radio Termination (PT):** See ETS 300 175-1 [1].

**public access service:** See ETS 300 175-1 [1].

**radio channel:** No defined meaning. See RF channel or physical channel.

**radio end point:** See ETS 300 175-1 [1].

**Radio Fixed Part (RFP):** See ETS 300 175-1 [1].

**Repeater Part (REP):** See ETS 300 175-1 [1].

**RF carrier (carrier):** See ETS 300 175-1 [1].

**RF channel:** See ETS 300 175-1 [1].

**simplex bearer:** See ETS 300 175-1 [1].

**Single Radio Fixed Part (SRFP):** See ETS 300 175-1 [1].

**TDMA frame:** See ETS 300 175-1 [1].

**Wireless Relay Station (WRS):** See ETS 300 175-1 [1].

### 3.2 Abbreviations

For the purposes of this ETS the following abbreviations apply:

ACP	Adjacent Channel Power
ACK	Acknowledgement
CCFP	Central Control Fixed Part
CI	Common Interface (standard)
CRFP	Cordless Radio Fixed Part
dBc	dB relative to the peak power of an unmodulated carrier
dBm	dB relative to 1 milliwatt
DECT	Digital Enhanced Cordless Telecommunications
DLC	Data Link Control layer
EIRP	Effective Isotropic Radiated Power
ERP	Effective Radiated Power
FP	Fixed Part
FT	Fixed radio Termination
GFSK	Gaussian Frequency Shift Keying
GMSK	Gaussian Minimum Shift Keying
LLME	Lower Layer Management Entity
MAC	Medium Access Control layer
PHL	Physical Layer
PHS	Portable HandSet
PP	Portable Part
ppm	parts per million
PT	Portable radio Termination
REP	Repeater Part
RF	Radio Frequency
RFP	Radio Fixed Part
RSSI	Radio Signal Strength Indicator

SAR	Specific Absorbtion Rate
TDD	Time Division Duplex
TDMA	Time Division Multiple Access
WRS	Wireless Relay Station

## 4 PHL services

A physical channel provides a simplex bit-pipe between two radio end points. To establish, for example, a duplex telephone connection, two physical channels have to be established between the endpoints.

Radio spectrum is needed to create a physical channel. The radio spectrum space has three dimensions:

- geometric (geographic) space;
- frequency; and
- time.

Spectrum is assigned to physical channels by sharing it in these three dimensions.

DECT provides a mechanism called "handover", to release a physical channel and to establish another one in any or all of the three dimensions without releasing the end to end connection.

The requirements of this part should be read in conjunction with I-ETS 300 176 [10].

The requirements specified apply for nominal conditions unless extreme conditions are stated. Tests at extreme conditions may include combinations of limit values of extreme temperature and of power supply variation, defined for each case in I-ETS 300 176 [10].

Nominal and extreme temperature ranges are defined below:

- Nominal temperature: PP, FP, RFP, CCFP + 15 °C to + 35 °C
- Extreme temperature: PP 0 °C to + 40 °C  
FP, RFP, CCFP, class E1 + 10 °C to + 40 °C  
FP, RFP, CCFP, class E2 - 10 °C to + 55 °C

The environmental class E1 refers to installation in indoor heated and/or cooled areas allowing for personal comfort, e.g. homes, offices, laboratories or workshops. The environmental class E2 refers to all other installations.

For nominal temperature, each measurement is made at the temperature of the test site, which shall be within + 15 °C to + 35 °C. For extreme temperatures, additional measurements are made, at each limit value of the extreme temperature.

### 4.1 RF channels (access in frequency)

#### 4.1.1 Nominal position of RF carriers

Ten RF carriers shall be placed into the frequency band 1 880-1 900 MHz with centre frequencies  $F_c$  given by:

$$F_c = F_0 - c \times 1,728 \text{ MHz}$$

where:  $F_0 = 1897.344 \text{ MHz}$ ; and  
 $c = 0, 1, \dots, 9$ .

Above this band, additional carriers are defined with centre frequencies  $F_c$  given by:

$F_c = F_9 + c \times 1,728 \text{ MHz}$   
and  $c \geq 10$  and RF band = 00001 (See ETS 300 175-3 [2], subclause 7.2.3.3.1).

The frequency band between  $F_c - 1,728/2$  MHz and  $F_c + 1,728/2$  MHz shall be designated RF channel c.

NOTE: A nominal DECT RF carrier is one whose centre frequency is generated by the formula:

$$F_g = F_0 - g \times 1,728 \text{ MHz ,}$$

where g is any integer.

All DECT equipment shall be capable of working on all 10 RF channels,  $c= 0,1, \dots, 9$ .

#### 4.1.2 Accuracy and stability of RF carriers

At a RFP the transmitted RF carrier frequency corresponding to RF channel c shall be in the range  $F_c \pm 50$  kHz at extreme conditions.

At a PP the centre frequency accuracy shall be within  $\pm 50$  kHz at extreme conditions either relative to an absolute frequency reference or relative to the received carrier, except that during the first 1 s after the transition from the idle-locked state to the active-locked state the centre frequency accuracy shall be within  $\pm 100$  kHz at extreme conditions relative to the received carrier.

NOTE: The above state transition is defined in ETS 300 175-3 [2].

The maximum rate of change of the centre frequency at both the RFP and the PP while transmitting, shall not exceed 15 kHz per slot.

#### 4.2 Time Division Multiple Access (TDMA) structure (access in time)

##### 4.2.1 Frame, full-slot, double-slot, and half-slot structure

To access the medium in time, a regular TDMA structure is used. The structure repeats in frames of 11 520 bits, and the data is transmitted at a bit rate of 1 152 kbit/s. Within this frame 24 full-slots are created, each consisting of two half-slots. A double slot has a length of two full slots, and starts concurrently with an even numbered full slot (see figures 1, 2, and 3).

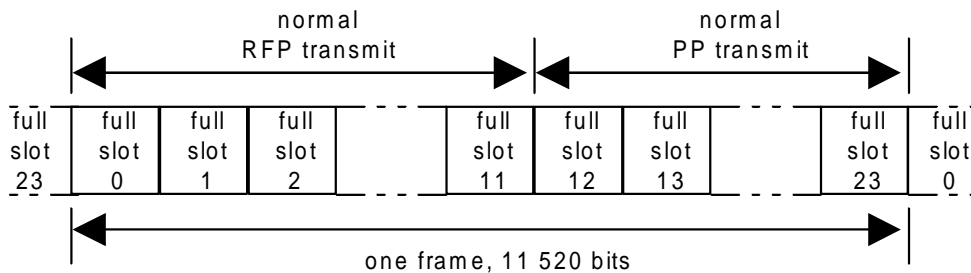

**Figure 1: Full slot format**

Full-slots are numbered from  $K = 0$  to 23, and half-slots are numbered  $L = 0$  or 1, where half-slot 0 occurs earlier than half-slot 1. Normally full-slots  $K = 0$  to 11 are used in the RFP to PP direction, while full slots  $K = 12$  to 23 are normally used in the PP to RFP direction. Double slots are numbered  $K = 0$  to 22 for even values of K.

Each full-slot has a duration of 480 bit intervals. Bit intervals within a full-slot are denoted  $f_0$  to  $f_{479}$  where interval  $f_0$  occurs earlier than interval  $f_1$ . Each half-slot has a duration of 240 bit intervals. Half-slots commence at  $f_0$  or  $f_{240}$  (see figure 2).

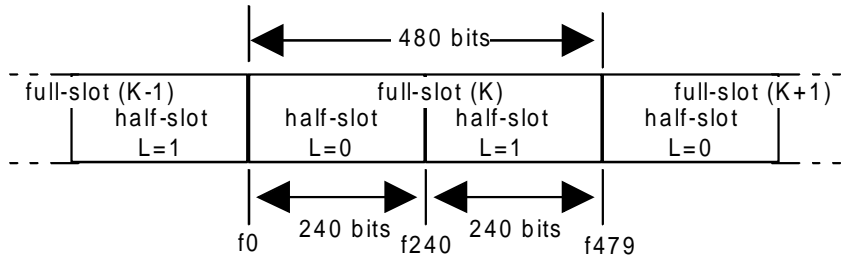

**Figure 2: Half-slot format**

Each double slot has a duration of 960 bit intervals. Bit intervals within a double slot are denoted  $f_0$  to  $f_{959}$ . Bits  $f_0$  to  $f_{479}$  coincide with the same notation for full slots with even  $K$ ,  $K(e)$ .

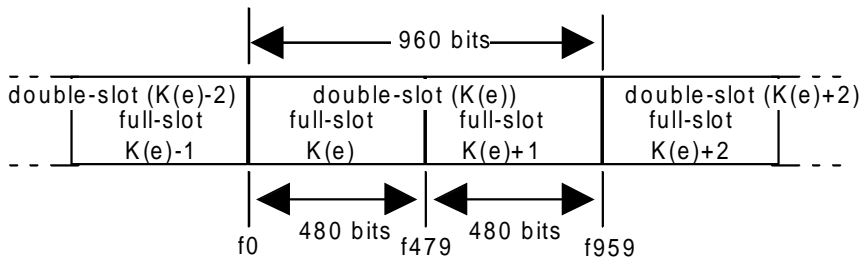

**Figure 3: Double slot format**

NOTE: Each radio end point has its own timing of the TDMA structure due to propagation delay and non-synchronized systems.

**4.2.2 Reference timer accuracy and stability**

The reference timer of a RFP or a PP is a notional clock to which the timing parameters of the TDMA framing are related.

A PP shall have its reference timer stability and accuracy better than 25 ppm at extreme conditions.

RFPs that can work with more than one duplex pair of physical channels per frame are known as multi-channel RFPs. Single channel RFPs can only work with one duplex pair of physical channels per frame (excluding handover situations).

A multi channel RFP shall have its reference timer stability and accuracy better than 5 ppm and better than 10 ppm at extreme conditions.

A single channel RFP shall have reference timer stability and accuracy better than 10 ppm at extreme conditions.

**4.2.3 RFP transmission jitter**

The nominal time when a packet should occur at the RFP antenna is (by this definition) synchronous to the RFP reference timer.

The jitter of a RFP packet transmission in a slot refers to the occurrence at the antenna of the start of bit  $p_0$  of that packet. The jitter is defined in relation to the reference timer of that RFP.

The jitter of a packet transmission shall be less than  $\pm 1 \mu s$  at extreme conditions.

The jitter between  $p_0$  and every other bit in a packet shall be within  $\pm 0,1 \mu s$ .

NOTE:  $0,1 \mu s$  corresponds to 250 ppm.

#### 4.2.4 PP reference timer synchronization

A PP shall take its reference timer parameters, including half-slot, full-slot, frame, multi-frame and receiver scan (see synchronization, ETS 300 175-3 [2]) from any channel of any of the RFPs that it is locked to.

It is allowed (but not required) to have more than one PP reference timer.

The reference timer used for a PP transmission to a RFP shall be synchronized to packets (see subclause 4.4) received from that RFP or from a RFP to which handover (see subclause 4.2.5) is allowed.

This reference timer for packet transmission timing is nominally (by this definition) synchronized to the time when the last packet used for synchronization occurred at the PP antenna.

When a PP transmits a packet, the start of transmission of bit p0 of the packet shall occur at the PP antenna  $\pm 2 \mu\text{s}$  at extreme conditions from the nominal transmission time as given by an ideal PP reference timer with 0 ppm accuracy. An exception is allowed for a dummy bearer change request packet transmission (see ETS 300 175-3 [2], subclause 7.2.5.6), when the nominal transmission time shall be given by the actual PP reference timer.

NOTE: The reason for the exception is that a residential PP may need to send the dummy bearer change request after a sudden slot theft in the idle locked mode. In this case the last synchronization of the reference timer can be more than 16 frame old. For all other packet transmissions, including bearer set up, the synchronization is normally less than one frame old.

The jitter between p0 and every other bit in a packet shall be within  $\pm 0,1 \mu\text{s}$ .

Connections to different RFPs are allowed (but not required) to have different reference timers.

#### 4.2.5 System synchronization

RFPs on the same FP shall be in half-slot, full-slot and frame synchronism. If handover is provided (see ETS 300 175-3 [2] and ETS 300 175-4 [3]), receiver scan and multiframe synchronism is also required.

The difference between reference timers of RFPs of the same FP shall be less than  $4 \mu\text{s}$  if handover is provided between these RFPs.

NOTE 1: Related to its reference timer, the PP or RFP synchronization window (see ETS 300 175-3 [2]) should be at least  $\pm 14$  bits, when expecting a first reception and if intracell handover is provided, else  $\pm 4$  bits.

NOTE 2: The case "handover" covers the general cases when a PP has physical channels to more than one RFP.

#### 4.2.6 Inter-system synchronization

Synchronization between FPs can be provided via an optional synchronization port (see annex C).

NOTE: RFPs of synchronized FPs should have geographically unique Fixed Part MAC Identities (FMIDs) (see ETS 300 175-6 [5]).

#### 4.2.7 Reference timer adjustment for synchronization

To obtain system and inter-system synchronization, a RFP or PP may alter the length of a single frame by any amount, or, it may alter the length of successive frames by up to 2 bits.

NOTE 1: Framelength alterations should be performed in accordance to the reference timer stability and accuracy requirements for RFPs and PPs as specified in subclause 4.2.2.

NOTE 2: If the timing of RFPs is adjusted outside the specification of subclause 4.2.2 then PPs are not expected to remain in the IDLE\_LOCKED state. Therefore such timing adjustments should be made as infrequently as possible by RFP reference timers.

### 4.3 Cells (access in space)

The third dimension to divide spectrum space is the geographical volume. Propagation losses may allow time-frequency combinations to be reused in different places.

### 4.4 Physical packets

Data is transmitted within the frequency, time, and space dimensions using physical packets. Physical packets shall be of one of the following types:

- short physical packet P00;
- basic physical packet P32;
- low capacity physical packet P08j;
- high capacity physical packet P80.

All RFPs shall be capable of transmitting, and all PPs shall be capable of receiving, short physical packets P00. All radio end points shall be capable of transmitting and receiving at least one of the physical packet types P32, P08j, or P80.

Each physical packet contains a synchronization field S and a data field D. The packets P80, P32 and P08j may contain an optional collision detection field, Z.

#### 4.4.1 The short physical packet P00

The short physical packet P00 consists of 96 data bits, used for dummy bearer and short slot connectionless data, transmitted by a RFP.

The data bits are denoted p0 to p95 where p0 occurs earlier than p1. When the packet is transmitted, the beginning of bit p0 coincides with the beginning of bit interval f0 of the full-slot being used (see figure 4).

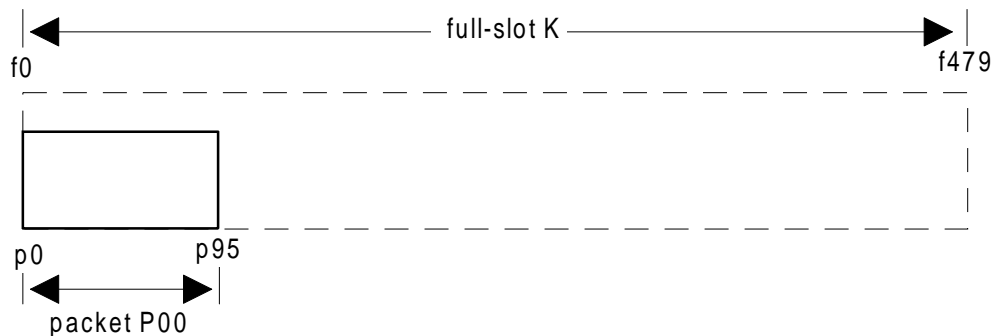

Figure 4: Short packet P00



#### 4.4.2 The basic physical packet P32

The basic physical packet P32, used in the most common types of connection (e.g. telephony), consists of 420 or 424 data bits.

The data bits are denoted  $p_0$  to  $p_{423}$  where  $p_0$  occurs earlier than  $p_1$ . When the packet is transmitted, the beginning of bit  $p_0$  coincides with the beginning of bit interval  $f_0$  of the full-slot being used (see figure 5).

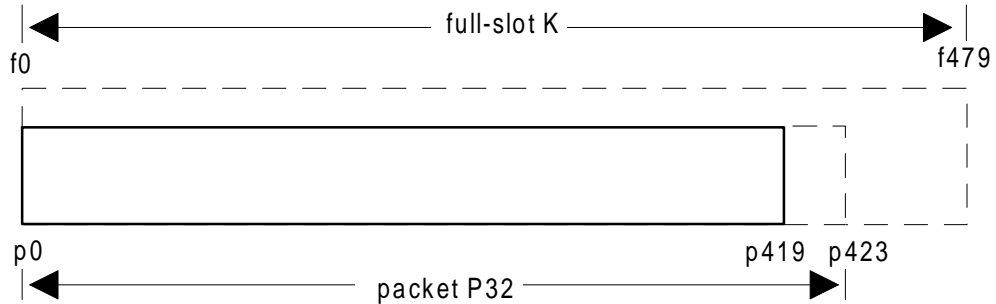

Figure 5: Basic packet P32

#### 4.4.3 The low capacity physical packet P08j

The low capacity physical packet P08j consists of  $180+j$  or  $184+j$  data bits.

The data bits are denoted  $p_0$  to  $p_{(183+j)}$  where  $p_0$  occurs earlier than  $p_1$ . Depending on the half-slot in use, the beginning of bit  $p_0$  coincides either with the beginning of bit interval  $f_0$  or the beginning of bit interval  $f_{240}$  of the full-slot being used (see figure 6).

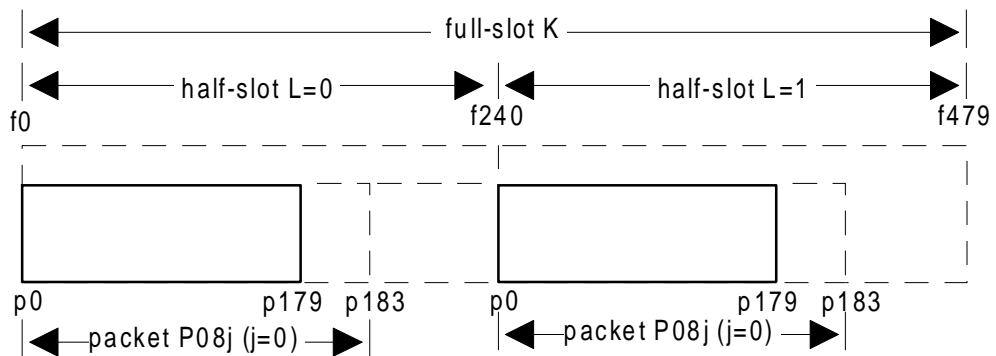

Figure 6: Low capacity packet P08j for  $j=0$ .

NOTE: Values of  $j$ , other than 0, are subject to future standardization.

#### 4.4.4 The high capacity physical packet P80

The high capacity physical packet P80 consists of 900 or 904 data bits.

The data bits are denoted p0 to p903 where p0 occurs earlier than p1. When the packet is transmitted, the beginning of bit p0 coincides with the beginning of bit interval f0 of the double-slot. Only even slot numbers K are defined (see figures 3 and 7).

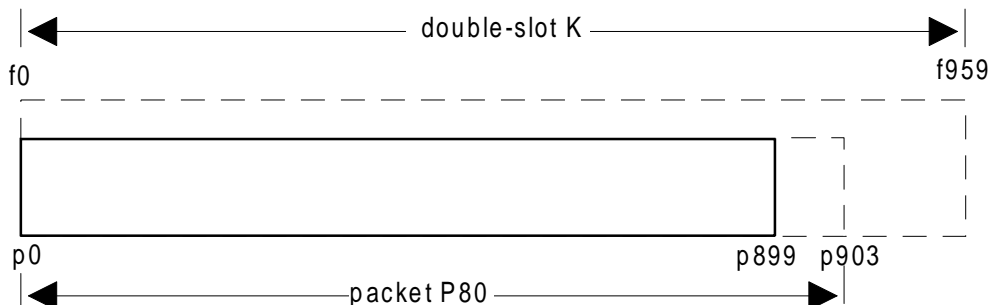

Figure 7: High capacity packet P80

#### 4.5 Physical channels

Physical channels shall be created by transmitting modulated physical packets as described in clause 5 on a particular RF channel, during a particular time in successive frames, at a particular location. Physical channels shall be set up between a PP and a RFP.

One physical channel can provide a connectionless, simplex service, and a pair of physical channels can provide a duplex speech call.

##### 4.5.1 Ra(K, L, M, N) notation

Physical channels shall be denoted as Ra(K,L,M,N). The parameters are:

- a = 00                      physical packet P00 in use;
- a = 32                      physical packet P32 in use;
- a = 08j                     physical packet P08j in use;
- a = 80                      physical packet P80 in use;
- K = {0,...,23}             the number of the full-slot in which transmission of the packet starts;
- L = 0                        packet transmission starts at bit interval f0;
- L = 1                        packet transmission starts at bit interval f240;
- M = {0,...,9}              the number of the RF channel used to transmit the physical packet;
- N                            the number, Radio fixed Part Number (RPN) (= N), of the radio fixed part using the physical channel. This parameter depends on the individual system and may be meaningless in many cases. It is, however, particularly helpful in describing handover algorithms;
- s=0                         normal preamble synchronization field;
- s=16                        prolonged preamble synchronization field;
- z=0                         no Z field;
- z=1                         Z field available.

NOTE: Prolonged preamble is defined in annex D. If a system employs prolonged preamble physical packets P00, P32, P08j and P80 will start at bit p-16. Figures 8, 9, 10 & 11 are drawn for normal preamble.

#### 4.5.2 The short physical channel R00(K,L,M,N)

The short physical channel, given in figure 8, shall be created by transmitting a physical packet P00 during full-slot K on carrier M in cell N, where:

- $0 \leq K \leq 23,$
- $L = 0,$
- $0 \leq M \leq 9,$  and
- N is arbitrary.
- $s = 0/16,$
- $z = 0/1.$

Packet P00 shall only be transmitted on full-slot boundaries.

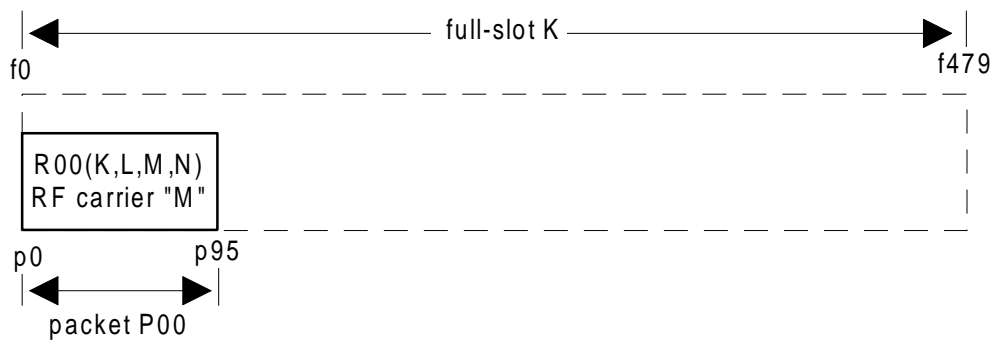

Figure 8: Short physical channel R00

#### 4.5.3 The basic physical channel R32(K,L,M,N)

The basic physical channel, given in figure 9, shall be created by transmitting a physical packet P32 during full-slot K on carrier M in cell N, where:

- $0 \leq K \leq 23,$
- $L = 0,$
- $0 \leq M \leq 9,$  and
- N is arbitrary.
- $s = 0/16,$
- $z = 0/1.$

Packet P32 shall only be transmitted on full-slot boundaries.

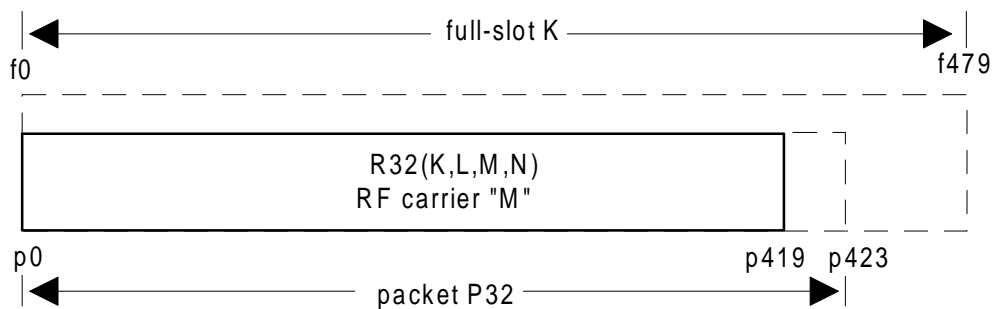

Figure 9: Basic physical channel R32

#### 4.5.4 The low-rate physical channel R08j(K,L,M,N)

The low rate physical channel, given in figure 10, shall be created by transmitting a physical packet P08j during the first or second half-slot of full-slot K on carrier M in cell N, where:

- $0 \leq K \leq 23$ ,
- $L = \{0,1\}$ ,
- $0 \leq M \leq 9$ , and
- N is arbitrary.
- $s = 0/16$ ,
- $z = 0/1$ .

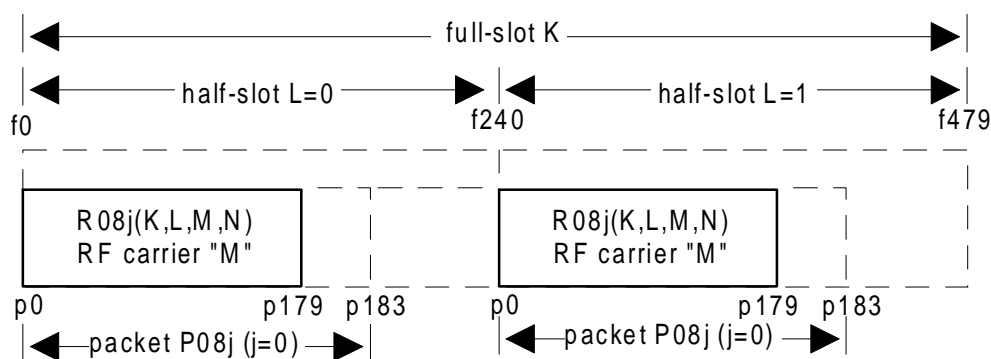

Figure 10: Low rate physical channel R08j for j = 0.

NOTE: Values of j, other than 0, are subject to future standardization.

#### 4.5.5 The high capacity physical channel R80(K,L,M,N)

The high capacity physical channel, given in figure 11, shall be created by transmitting a physical packet P80 during double-slot K on carrier M in cell N, where:

- $0 \leq K \leq 22$  and K is an even number,
- $L = 0$ ,
- $0 \leq M \leq 9$ , and
- N is arbitrary.
- $s = 0/16$ ,
- $z = 0/1$ .

Packet P80 shall only be transmitted on boundaries of a full slot with an even value of K.

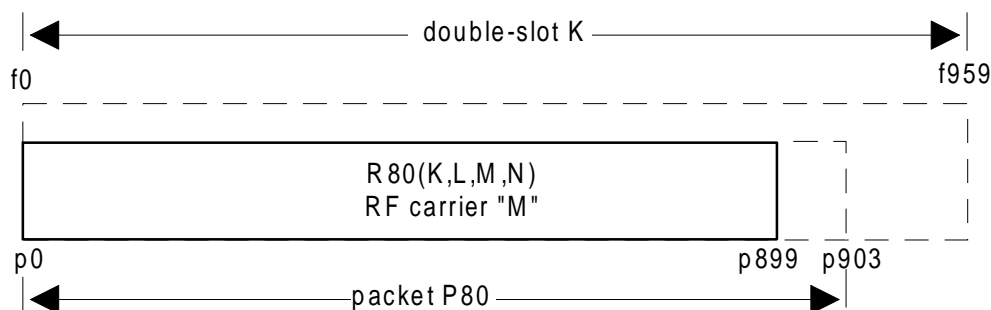

Figure 11: High capacity physical channel R80

#### 4.6 Synchronization field S

The synchronization field S may be used by the receiver for clock and packet synchronization of the radio link. The first 16 bits are a preamble, and the last 16 bits are the packet synchronization word.

The field contains 32 bits denoted s0 to s31 and is transmitted in bits p0 to p31. Starting with s0, the synchronization bits are defined as follows:

RFP transmissions:

1010 1010 1010 1010    1110 1001 1000 1010 (binary)  
 s05                            s15 s16                            s31

PP transmissions:

0101 0101 0101 0101    0001 0110 0111 0101 (binary)  
 s0                            s15 s16                            s31

The two bit sequences s0 - s31 are the inverse of each other.

Annex D outlines an optional prolonged preamble field which extends the preamble bit pattern by 16 bits. This prolonged preamble field may be used by a receiver for implementation of an antenna selection diversity algorithm.

#### 4.7 D-field

##### 4.7.1 Physical packet P00

The D-field contains 64 bits denoted d0 to d63 and is transmitted in bits p32 to p95 (see figure 12).

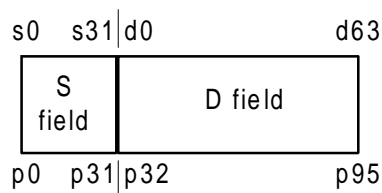
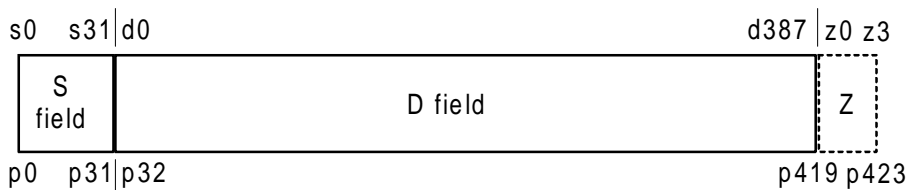

Figure 12: P00 packet

**4.7.2 Physical packet P32**

The D-field contains 388 bits denoted d0 to d387 and is transmitted in bits p32 to p419 (see figure 13).



**Figure 13: Packet P32**

**4.7.3 Physical packet P08j**

The D-field contains 148+j bits denoted d0 to d(147+j) and shall be transmitted in bits p32 to p(179+j) (see figure 14).

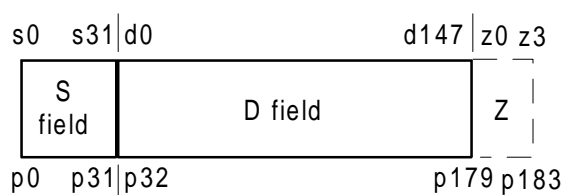
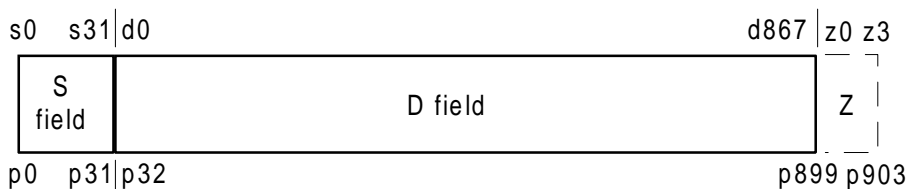

**Figure 14: Packet P08j for j = 0**

NOTE: Values of j, other than 0, are subject to future standardization.

**4.7.4 Physical packet P80**

The D-field contains 868 bits denoted d0 to d867 and is transmitted in bits p32 to p899 (see figure 15).



**Figure 15: Packet P80**

**4.8 Z-field**

The Z-field may be used by the receiver for early detection of an unsynchronized interference sliding into the end of the physical packet P32, P08j, or P80.

NOTE: Unsynchronized interference sliding into the beginning of a physical packet can be detected by monitoring bit errors in the S-field.

The Z-field contains 4 bits, z0 to z3, immediately following the last bit of the D-field (see figure 16).

The bits z0 to z3 shall be set equal to the 4 last bits of the D-field. These last 4 bits are the X-field (see ETS 300 175-3 [2]).

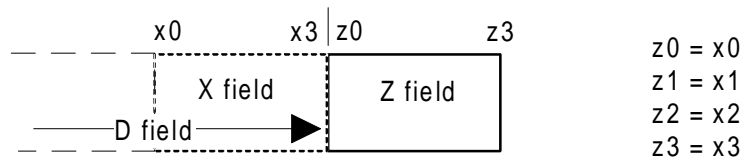

**Figure 16 : The Z-field**

The provision of the Z-field operation is optional, subject to mandatory requirements of profiles (see ETS 300 444 [9]).

**NOTE:** The Z-field is especially useful for the  $I_N$  services like speech (see ETS 300 175- 3 [2]). By comparing the received Z-field with a correctly received X-field, an early sliding interferer (X correct and errors in Z) can be distinguished from an unsynchronized slot theft that also corrupts the D-field, e.g. speech (errors in X). Optimized handover procedures can be applied for each case.

#### 4.9 Bit pattern during ramping

During the intervals before and after the physical packets when the transmitter power is ramped up and down (see subclauses 5.2.1 and 5.2.2) the transmitter bit pattern is not defined. However, it is recommended that during ramp up the modulator generates a bit pattern which is the natural extension of the preamble bit pattern (see subclause 4.6).

## 5 Transmission of physical packets

### 5.1 Definitions

#### 5.1.1 End of the physical packet

The physical packet P00 ends at the end of bit p95.

The physical packet P32 ends at the end of bit p419 or p423.

The physical packet P08j ends at the end of bit p(179+j) or p(183+j).

The physical packet P80 ends at the end of bit p899 or p903.

#### 5.1.2 Transmitted power

This is the mean power delivered over one radio frequency cycle.

#### 5.1.3 Normal Transmitted Power (NTP)

The NTP is the transmitted power averaged from the start of bit p0 of the physical packet, to the end of the physical packet.

### 5.2 Transmission burst

The transmission requirements are defined in subclauses 5.2.1 to 5.2.6 and graphically represented in figure 17.

#### 5.2.1 Transmitter attack time

This is the time taken for the transmitted power to increase from 25  $\mu$ W to the time that the first bit of the physical packet, p0, starts transmission.

The transmitter attack time shall be less than 10  $\mu$ s at extreme conditions.

**5.2.2 Transmitter release time**

This is the time taken from the end of the physical packet for the transmitted power to decrease to 25  $\mu$ W.  
 The transmitter release time shall be less than 10  $\mu$ s at extreme conditions.

**5.2.3 Minimum power**

From the first bit of the packet, p0, to the end of the physical packet, the transmitted power shall be greater than (NTP - 1 dB) at extreme conditions.

**5.2.4 Maximum power**

From 10  $\mu$ s after the start of bit p0 to 10  $\mu$ s after the end of the physical packet, the transmitted power shall be less than (NTP + 1 dB) at extreme conditions.

From 10  $\mu$ s before the start of bit p0 to 10  $\mu$ s after the start of bit p0, the transmitted power shall be less than (NTP + 4 dB) and less than 315 mW at extreme conditions.

**5.2.5 Maintenance of transmission after packet end**

The transmitted power shall be maintained greater than (NTP - 6 dB) for 0,5  $\mu$ s after the end of the physical packet at extreme conditions.

**5.2.6 Transmitter idle power output**

For the time period starting 27  $\mu$ s after the end of the physical packet and finishing 27  $\mu$ s before the next transmission of a data bit p0, the transmitter idle power shall be less than 20 nW, except when p0 of the next transmitted packet occurs less than 54  $\mu$ s after the end of the transmitted physical packet.

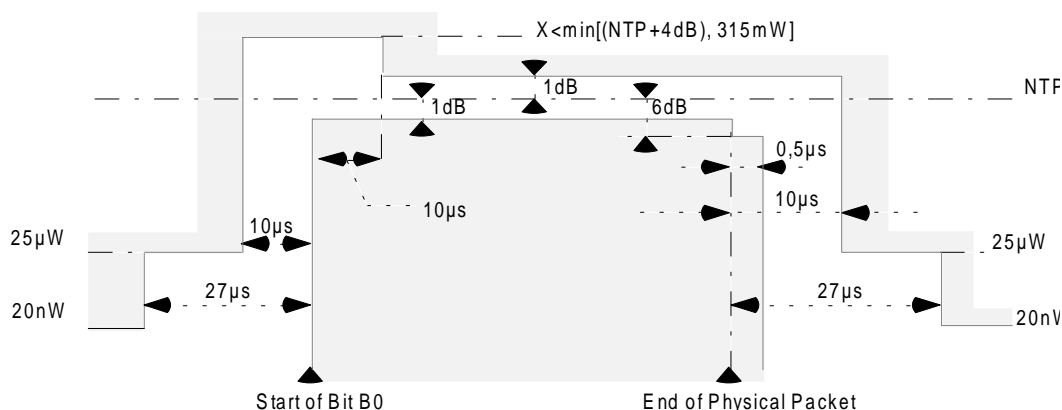

**Figure 17: Physical packet power-time template**



### 5.3 Transmitted power

#### 5.3.1 Peak power per transceiver

##### 5.3.1.1 PP and RFP with an integral antenna

The equivalent isotropically radiated NTP shall be less than  $P_{NTP}$  per simultaneously active transceiver at nominal conditions.

The transmitter power  $P_{NTP}$  is defined in the following table.

Power level	$P_{NTP}$ (mW)
Level 1	2,5
Level 2	250

##### 5.3.1.2 PP and RFP with external connections for all antennas

A matched load is connected to each antenna port of the PP or RFP and the power delivered to these loads is measured.

For a radio end point with more than one antenna port, the instantaneous power from each antenna port shall be added together to give the NTP.

The NTP shall be less than  $P_{NTP}$  per simultaneously active transceiver at extreme conditions.

NOTE: The antenna gain should in the majority of applications be no more than 12 dBi, but may for specific applications be up to 22 dBi. Use of antenna gain values higher than 12 dBi may be subject to agreement with national radio authorities.

#### 5.3.2 Maximum EIRP and number of transceivers

The safety requirements of annex A shall be met.

### 5.4 RF carrier modulation

#### 5.4.1 Modulation method

The modulation method shall be Gaussian Frequency Shift Keying, (GFSK), with a bandwidth-bit period product of nominally 0,5.

#### 5.4.2 Definition of "1" and "0"

A binary "1" is encoded with a peak frequency deviation of (+ f), giving a peak transmit frequency of ( $F_c + f$ ), which is greater than the carrier frequency of ( $F_c$ ). A binary "0" is encoded with a peak frequency deviation of (- f), giving a peak transmit frequency of ( $F_c - f$ ).

The nominal peak deviation (f) shall be 288 kHz.

### 5.4.3 Deviation limits

The achieved deviation in any given PP or RFP may vary from this nominal value as follows:

NOTE 1: These limits apply equally to positive and negative deviations.

Case A: Case A shall apply to the transmission of a repeating binary sequence of four "1"s and four "0"s:

....000011110000111100001111....

The deviation limits for case A shall be:

- peak deviation greater than 259 kHz (90 % of nominal);
- peak deviation less than 403 kHz (140 % of nominal).

Case B: Case B shall apply to the transmission of all other binary sequences (sequences both longer and shorter than case A) that contain a maximum "digital sum variation" (see note 2) with an absolute value equal to or less than sixty four.

The deviation limits for case B shall be:

- peak deviation greater than 202 kHz (70 % of nominal);
- peak deviation less than 403 kHz (140 % of nominal).

NOTE 2: Case B includes the case of a ".1010." sequence.

NOTE 3: "Digital Sum Variation" (DSV) is defined as the cumulative total of all transmitted symbols, counted from the start of the transmission burst. A binary "1" counts as (+ 1); a binary "0" as (- 1). The DSV total indicates the cumulative DC balance of the transmitted symbols.

## 5.5 Unwanted RF power radiation

### 5.5.1 Emissions due to modulation

With transmissions on physical channel Ra(K,L,M,N) in successive frames, the power in physical channel Ra(K,L,Y,N) shall be less than the values in table.

**Table 1**

Emissions on RF channel "Y"	Maximum power level
Y = M ± 1	160 µW
Y = M ± 2	1 µW
Y = M ± 3	40 nW
Y = any other DECT channel	20 nW
NOTE: For Y = "any other DECT channel", the maximum power level shall be less than 20 nW except for one instance of a 500 nW signal.	

The power in RF channel Y is defined by integration over a bandwidth of 1 MHz centred on the nominal centre frequency, Fy, averaged over at least 60 % but less than 80 % of the physical packet, and starting before 25 % of the physical packet has been transmitted but after the synchronization word.

**5.5.2 Emissions due to transmitter transients**

The power level of all modulation products (including Amplitude Modulation (AM) products due to the switching on or off of a modulated RF carrier) arising from a transmission on RF channel M shall, when measured using a peak hold technique, be less than the values given in table 2. The measurement bandwidth shall be 100 kHz and the power shall be integrated over a 1 MHz bandwidth centred on the DECT frequency,  $F_y$ .

**Table 2**

<b>Emissions on RF channel "Y"</b>	<b>Maximum power level</b>
$Y = M \pm 1$	250 $\mu$ W
$Y = M \pm 2$	40 $\mu$ W
$Y = M \pm 3$	4 $\mu$ W
Y = any other DECT channel	1 $\mu$ W

**5.5.3 Emissions due to intermodulation**

The power level of intermodulation products that are on any DECT physical channel when any combination of the transmitters at a radio end point are in calls on the same slot on different frequencies shall be less than 1  $\mu$ W. The power level is defined by integration over the 1 MHz centred on the nominal centre frequency of the afflicted channel and averaged over the time period in subclause 5.5.1.

**5.5.4 Spurious emissions when allocated a transmit channel**

The peak power level of any RF emissions outside the radio frequency band allocated to DECT, as defined in subclause 4.1.1, when a radio end point has an allocated physical channel, shall not exceed 250 nW at frequencies below 1 GHz and 1  $\mu$ W at frequencies above 1 GHz. The power shall be defined in the bandwidths given in table 3. If a radio end point has more than one transceiver, any out of band transmitter intermodulation products shall also be within these limits.

**Table 3**

<b>Frequency offset, <math>f_o</math> from edge of band</b>	<b>Measurement bandwidth</b>
$0 \text{ MHz} \leq f_o < 2 \text{ MHz}$	30 kHz
$2 \text{ MHz} \leq f_o < 5 \text{ MHz}$	30 kHz
$5 \text{ MHz} \leq f_o < 10 \text{ MHz}$	100 kHz
$10 \text{ MHz} \leq f_o < 20 \text{ MHz}$	300 kHz
$20 \text{ MHz} \leq f_o < 30 \text{ MHz}$	1 MHz
$30 \text{ MHz} \leq f_o < 12,75 \text{ GHz}$	3 MHz

Measurements shall not be made for transmissions on the RF channel closest to the nearest band edge for frequency offsets of up to 2 MHz.

In addition, not regarding up to 2 instances of a continuous-wave spurious signal for PPs for which the total peak power level shall be less than 250 nW as measured in a 3 MHz measurement bandwidth, the peak power level shall be less than 20 nW in a 100 kHz measuring bandwidth for the following broadcast bands:

47	-	74 MHz;
87,5	-	108 MHz;
108	-	118 MHz;
174	-	230 MHz;
470	-	862 MHz.

## 6 Reception of physical packets

### 6.1 Definitions and conditions for clause 6

#### 6.1.1 Power levels and field strength

In this subclause, the requirements are given in terms of power levels at the receiver input. Equipment without an external antenna connection may be taken into account by assuming that they have a 0 dBi gain antenna and converting these power level requirements into field strength requirements. This means that the tests on equipment without an external antenna will consider field strengths (E) related to the power levels (P), as specified by the following formula:

$$E \text{ (dB}\mu\text{V/m)} = P \text{ (dBm)} + 142,7$$

derived from:

$$E = P + 20 \log F \text{ (MHz)} + 77,2, \text{ and assuming } F = 1\ 890 \text{ MHz.}$$

#### 6.1.2 Test conditions

Steady state, non-fading conditions are assumed for both wanted and unwanted signals.

#### 6.1.3 Reference DECT radio end point

A "reference DECT radio end point" is a DECT equipment that meets the criteria for a reference DECT radio as given in I-ETS 300 176 [10]. Two of the requirements for the reference DECT radio end point are:

- transmit power of 250 mW  $\pm$  1 dB is maintained from the beginning of bit p0 to the end of the physical packet, as defined in subclause 5.1.1;
- use of GMSK modulation with BT = 0,5, thus giving an adjacent channel interference level of 40 dB below 250 mW.

A reference DECT interferer is a continuous transmission as defined in I-ETS 300 176 [10].

### 6.2 Radio receiver sensitivity

The radio receiver sensitivity is defined as the power level at the receiver input at which the Bit Error Rate (BER) is 0,001 in the D-field.

The radio receiver sensitivity shall be - 83 dBm (i.e. 60 dB $\mu$ V/m), or better. This limit shall be met for a reference DECT radio end point transmitted frequency error of  $\pm$  50 kHz for PPs and RFPs.

This requirement shall be met with the radio end point under test operating in time division duplex mode with a reference DECT radio end point.

Before using a DECT physical channel for transmission or reception, the receiver shall be able to measure the strength of signals on that physical channel, that are received stronger than - 93 dBm (i.e. 50 dB $\mu$ V/m) and weaker than - 33 dBm (i.e. 110 dB $\mu$ V/m) with a resolution of better than 6 dB. Signals that are received weaker than - 93 dBm shall produce a result equal to, or less than that produced by a signal of - 93 dBm. Signals that are received stronger than - 33 dBm shall produce a result equal to, or greater than that produced by a signal of - 33 dBm.

### 6.3 Radio receiver reference bit error rate

The radio receiver reference bit error rate is the maximum allowed bit error rate for a power level at the receiver input of - 73 dBm or greater (i.e. 70 dB $\mu$ V/m).

The reference bit error rate is 0,00001 in the D-field.

### 6.4 Radio receiver interference performance

With a received signal strength of - 73 dBm (i.e. 70 dB $\mu$ V/m) on RF channel M, the BER in the D-field shall be maintained better than 0,001 when a modulated, reference DECT interferer of the indicated strength is introduced on the DECT RF channels shown in table 4.

**Table 4**

Interferer on RF channel "Y":	Interferer signal strength	
	(dB $\mu$ V/m)	(dBm)
Y = M	60	- 83
Y = M $\pm$ 1	83	- 60
Y = M $\pm$ 2	104	- 39
Y = any other DECT channel	110	- 33
NOTE: The RF carriers "Y" shall include the three nominal DECT RF carrier positions immediately outside each edge of the DECT band.		

### 6.5 Radio receiver blocking

#### 6.5.1 Owing to signals occurring at the same time but on other frequencies

The receiver should work in the presence of strong signals on other frequencies. These interferers may be modulated carriers or single frequency signals. The operation in the presence of DECT modulated signals has been described in subclause 6.4.

With the desired signal set at - 80 dBm, the BER shall be maintained below 0,001 in the D-field in the presence of any one of the signals shown in table 5.

**Table 5**

Frequency (f)	Continuous-wave interferer level	
	for radiated measurements (dB $\mu$ V/m)	for conducted measurements dBm
25 MHz $\leq$ f < 1 780 MHz	120	-23
1 780 MHz $\leq$ f < 1 875 MHz	110	-33
f - Fc   > 6 MHz	100	-43
1 905 MHz < f $\leq$ 2 000 MHz	110	-33
2 000 MHz < f $\leq$ 12,75 GHz	120	-23

### 6.5.2 Owing to signals occurring at a different time

With a signal of strength - 14 dBm (i.e. 129 dB/μVm) incident on the receiver in slot "N" on RF carrier "M", the receiver shall be able to receive at - 83 dBm, and with the BER in the D-field maintained better than 0,001, on slot (N + 2) modulo 24 on any DECT RF carrier.

### 6.6 Receiver intermodulation performance

With a call set up on a particular physical channel, two interferers are introduced so that they can produce an intermodulation product on the physical channel already in use.

If RF carrier number "d" is in use, a reference DECT interferer and a continuous wave interferer are introduced on DECT carriers "e" and "f" to produce an intermodulation product on carrier "d". Neither "e" nor "f" shall be adjacent to "d".

With "e" and "f" being received 33 dB greater than "d", and "d" being received at - 80 dBm, the receiver shall still operate with a BER of less than 0,001 in the D-field.

### 6.7 Spurious emissions when not allocated a transmit channel

#### 6.7.1 Out of band

The power level of any spurious emissions when the radio end point has no allocated transmit channel shall not exceed 2 nW between 30 MHz and 1 GHz. Between 1 GHz and 12,75 GHz the power level shall not exceed 20 nW.

The power shall be measured using a peak hold technique with a 100 kHz measurement bandwidth.

#### 6.7.2 In the DECT band

The power level of any spurious emissions within the DECT band shall not exceed 2 nW measured in a 1 MHz bandwidth. The following exceptions are allowed:

- a) in one 1 MHz band, the maximum allowable Effective Radiated Power (ERP) shall be less than 20 nW;
- b) in up to two bands of 30 kHz, the maximum ERP shall be less than 250 nW.

## 7 Primitives between physical layer and other entities

The contents of this clause are provided for information only. This clause is aimed to assist in the description of layer to layer procedures.

These primitives are abstract and their concrete representations may vary from implementation to implementation. Therefore, they shall not be considered to be a testable entity.

In the parameter lists in this clause:

- X = this parameter is present in this primitive;
- = this parameter is not present in this primitive;
- O = this parameter is optional.

## 7.1 Medium access control layer (D-SAP)

The physical layer communicates with the MAC Layer by primitives through the D-SAP (SAP = Service Access Point). The D-SAP is mainly used to exchange D-fields between the PHL and the MAC Layer. In addition this SAP may be used for frequency adjustment purposes and sliding collision information.

D-field segments may be passed through the D-SAP in either direction, depending upon whether the segments have to be transmitted or received by the PHL. The Service Data Unit (SDU) length of primitives carrying one D-field corresponds to the D-field length of the physical packet in use (see subclause 4.7).

The following primitives are exchanged through the D-SAP:

For D-Field transmissions:	PL_TX {req};
for D-Field receptions:	PL_RX {req,cfm};
for frequency adjustment:	PL_FREQ_ADJ {req}.

### 7.1.1 PL\_TX {req}

The MAC layer supplies the physical layer with the D-field, the physical channel number on which it is to be transmitted and an optional command to add the Z-field. The physical channel number defines the length of the D-field.

**Table 6: PL\_TX parameter list**

Parameter	Primitive type	
	Request	Confirm
D-field	X	-
a	X	-
K	X	-
L	X	-
M	X	-
add Z field	O	-
s	O	-

**7.1.2 PL\_RX {req,cfm}**

The MAC layer supplies the physical layer with a physical channel number excluding RPN.

The confirm primitive contains a "valid synchronization word" and the "D-field", and optionally, "frequency error" and "sliding collision information".

**Table 7: PL\_RX parameter list**

Parameter	Primitive type	
	Request	Confirm
a	X	-
K	X	-
L	X	-
M	X	-
valid synchronization word	-	X
D field	-	X
frequency error	-	O
sliding collision information	-	O

**7.1.3 PL\_FREQ\_ADJ {req,}**

With a request primitive the MAC layer instructs the physical layer to increase or decrease the transmit or receive centre frequency by a given small amount (this is not the "change RF channel" command). The physical layer may respond with a confirm primitive which indicates that the function is not supported.

If this function is not supported the physical layer may issue a PL\_FREQ\_ADJ-cfm primitive.

NOTE: The PL-FREQ\_ADJ message is defined in ETS 300 175-3 [2].

**7.2 Management entity (PM-SAP)**

The physical layer communicates with the lower layer management entity by primitives through the PM-SAP. The primitives passed through the PM-SAP are mainly used to invoke and control physical layer processes.

The following primitives are exchanged through the PM-SAP:

PL\_ME\_SYNC {req,cfm};

PL\_ME\_SIG\_STR {req,cfm};

PL\_ME\_TIME\_ADJ {req,cfm}.

**7.2.1 PL\_ME\_SYNC {req,cfm}**

The ME requests the physical layer to search, over a time and frequency period, for a synchronization pulse.



### 7.2.2 PL\_ME\_SIG\_STR {req,cfm}

The ME requests the physical layer to provide a measure of the signal strength on physical channel Ra(K,L,M,N). The signal strength is measured according to the description in subclause 8.3.

The confirm primitive contains the measured signal strength relative to some internal standard.

### 7.2.3 PL\_ME\_TIME\_ADJ {req,cfm}

The ME requests the physical layer to lengthen or shorten a single frame by a given amount.

An RFP uses this timing adjustment for intra-system or inter-system synchronization. A PP uses this timing adjustment to lock to an RFP.

## 8 PHL procedures

### 8.1 Addition of synchronization field and transmission

When the PHL receives a PL\_TX-req primitive, the appropriate synchronization field, defined in subclause 4.6, shall be added and the Z-field, subclause 4.8, may be added and the complete physical packet shall be transmitted on the next slot of physical channel Ra(K,L,M,N).

If the Z-field is added, it shall be transmitted during the entire existence of a simplex bearer.

### 8.2 Packet reception and removal of synchronization field

When the PHL receives a PL\_RX-req primitive it shall:

- a) receive the specified physical packet in the next occurrence of the specified physical channel;
- b) acquire and confirm slot synchronization using the synchronization field.

NOTE 1: Different parameters may be used for initial slot acquisition and slot maintenance. For example synchronization window size and required synchronization pulse height may differ.

NOTE 2: The time of the derived synchronization pulse maybe used to adjust the PP reference timer.

NOTE 3: One correlator can detect and distinguish the related PP and RFP synchronization words (see subclause 4.6).

- c) deliver the D-field data to the MAC layer.

NOTE 4: The size of the D-field depends on the specified physical channel.

- d) optionally report the frequency error of the received channel to the MAC layer.

NOTE 5: This is used by an RFP to operate frequency control of PPs.

- e) report sliding collision information to the MAC layer. This is optional subject to mandatory requirements of profiles.

NOTE 6: It is not mandatory to understand the Z-field or to have the receiver active to receive it, except when mandated in a profile. The Z-field is compared with the X-field in order to detect Z-field errors.

Whether or not a Z-field is transmitted could be detected by 2 consecutive receptions of "Z-field = X-field" during the first 8 frames of a bearer transmission. Sliding collision information parameters could be "Zack" if  $Z = X$ , "Znack" if Z not equal to X, and "Zno" if the Z-field is not transmitted. Collision at the beginning of a slot can be detected by monitoring errors in the synchronization field and could be reported e.g. as "SN", where N is the number of consecutive error free bits in the last part of the preamble of the S-field, or report deviation from a "stable" N. Requirements for sliding collision detection for a profile is given in annex B.

NOTE 7: When sliding collision indication using the Q1 bit is sent from the RFP to the PP, Q1 may be set to 1, e.g. if there are errors in the S-field or the-Z field, while the A-field is correct (see ETS 300 175-3 [2], annex F).

### 8.3 Measurement of signal strength

On receipt of a PL\_ME\_SIG\_STR-req primitive, the physical layer measures the signal strength on the requested physical channel.

When using this primitive, the signal strength is the peak value obtained from a circuit with a time constant of between 10  $\mu$ s and 40  $\mu$ s.

The peak measurement shall extend over the complete packet (packet P00, P32 or P08j depending upon the intended use) and should also include a pre-packet interval of at least 10  $\mu$ s and a post-packet interval of at least 10  $\mu$ s.

The signal strength is integrated over a bandwidth of nominally 1 MHz centred on the received RF carrier centre frequency.

### 8.4 Synchronization pulse detection

When the PHL receives a PL\_ME\_SYNC-req primitive, the PHL searches for a valid synchronization pulse.

### 8.5 Timing adjustment

When the PHL receives a PL\_ME\_TIME\_ADJ-req primitive, it may adjust the length of the next frame by the requested amount.

### 8.6 Frequency adjustment

The PHL may receive a PL\_FREQ\_ADJ-req primitive in order to adjust its local oscillator. The PHL may react upon this primitive by adjusting its oscillator. Adjusting the oscillator shall be done within 30 ms after transmission of the PL-FREQ\_ADJ message by the FT.

If this function is not supported the PHL may issue a PL\_FREQ\_ADJ-cfm primitive.

NOTE: The PL-FREQ\_ADJ message is defined in ETS 300 175-3 [2].

## **9 Management entity procedures related to PHL**

### **9.1 List of quietest physical channels**

Using the signal strength measurements obtained with the PL\_ME\_SIG\_STR primitives, the LLME produces an ordered list of least interfered channels.

The resolution of the signal strengths is specified in subclause 6.2.

Physical channels with actual signal strengths that differ by less than this resolution may be listed in any order.

Physical channels with actual signal strengths that differ by greater than this resolution shall be listed in their actual order.

NOTE: This subclause does not prevent a PP or RFP from considering the interference on physical channel pairs.

### **9.2 Physical channels with greatest field strength (PP only)**

Using the signal strength measurements obtained with the PL\_ME\_SIG\_STR primitives, the LLME in a PP produces an ordered list of physical channels with the greatest signal strength.

The resolution of the signal strengths is specified in subclause 6.2.

Physical channels with actual signal strengths that differ by less than this resolution may be listed in any order.

Physical channels with actual signal strengths that differ by greater than this resolution shall be listed in their actual order.

NOTE: This information is used with higher layer information to identify the strongest RFPs.

### **9.3 Extract timing**

Using the PL\_ME\_SYNC primitives, and interworking with higher layer detection of slot numbers, the LLME shall establish the slot and frame timing.

## Annex A (normative): Safety requirements

The contents of this annex is based upon the following documents:

"Guidelines on limits of exposure to radio frequency electromagnetic fields in the frequency range from 100 kHz to 300 GHz";

"Proposed revision of the Canadian recommendations on radio frequency-exposure protection".

This annex may be subject to change as new European safety norms on radio equipment are introduced.

### A.1 Recommendation

The electric field exposure limit of 60 V/m shall not be exceeded, when averaged over a period of 6 minutes. This limit can be exceeded, if the following demands are satisfied:

- a) the Specific Absorption Rate (SAR) averaged over any 0,2 kg of the body mass does not exceed 0,2 W/kg;
- b) the local SAR in the eye does not exceed 0,4 W/kg;
- c) the local SAR averaged over any gram of tissue does not exceed 4 W/kg, except on the body surface or in the limbs (arms and legs), where the maximum SAR is 12 W/kg;
- d) all above limits are averaged over 6 minutes.

In the case of pulsed fields, the peak field strength shall not exceed 32 times the continuous wave limit of 60 V/m.

### A.2 Safety distances

From the above recommendation the following safety distances can be derived, where safety distance means the recommended minimum distance of any part of the body to the antenna:

- a) if the maximum Effective Isotropic Radiated Power (EIRP), averaged over 1 frame, is below 240 mW, no safety distance is needed.

NOTE: This means that, if the duration of one burst is not longer than 400  $\mu$ s, then in the 10 ms frame you could transmit for example 24 such bursts with a maximum peak EIRP of 250 mW each, or one burst with a maximum peak EIRP of up to 6 W.

- b) if the maximum EIRP, averaged over 1 frame, is between 240 mW and 1 W, a safety distance of 10 cm is recommended;
- c) if the maximum EIRP, averaged over 1 frame, exceeds 1 W a safety distance of:

$$d[\text{m}] = 0,1 \times \sqrt{\text{maximum average EIRP}[\text{W}]}$$

is recommended.

## **Annex B (informative): Public Access Profile (PAP): mandatory requirements regarding the physical layer**

This annex is a reprint from clause 10 of ETS 300 175-9 [8] and contains the elements specified in this part of the ETS. In the event of any conflict between this annex and ETS 300 175-9 [8], the text in the latter shall be the prime source (i.e. part 9 is normative).

Public access equipment shall provide at least all of the elements stated below.

### **B.1 Minimum Normal Transmit Power (NTP)**

The nominal NTP shall be greater than 80 mW per simultaneously active transmitter as shown by the test verdict criteria and declaration of I-ETS 300 176 [10], subclauses 10.2.3, 10.2.4 and 10.2.5.

### **B.2 Radio receiver sensitivity**

The RFP radio receiver sensitivity shall be - 86 dBm, or better.

### **B.3 Z-field**

The Z-field shall be transmitted and received by RFPs and PTs.

### **B.4 Sliding collision detection**

PT and FT shall be able to detect sliding collision on received packets.

Minimum criteria for sliding collision is defined as S- or Z-field failure. Early sliding collision detection may be supported by other means e.g. signal strength measurements in the guard band.

The Z-field is defined to have failed if the received X- and Z-fields are not identical.

S-field failure is defined with some tolerance in order not to restrict the physical implementation of the word synchronization detector.

S-field failure may be indicated if there are 1 or more bit errors in bits s12 to s31 (errors in bits s0 to s11 shall be ignored). In all cases, S-field failure shall be indicated if 3 or more bit errors occur in bits s16 to s31.

### Annex C (normative): Synchronization Port

Frame synchronization between adjacent DECT FPs is possible if they are provided with a "DECT Synchronization Port".

Depending on application, the port shall meet the requirements of Class 1 or Class 2. Class 1 is intended for mutually increased traffic capacity of adjacent systems by aligning guard bands. Class 2 is intended for the case when handover is to be provided between the systems.

#### C.1 Synchronization Ports

##### C.1.1 External synchronization output port

The external synchronization output port shall conform to RS422 section 4.1 (see Annex E).

The external synchronization output port shall be marked "SYNC OUT".

If connection terminals are used, one terminal shall be marked **A** (corresponding to A in RS422) and the other terminal shall be marked **B** (corresponding to B in RS422).

If a connector is used, it shall be a modular telephone jack with 6 contacts (such as RJ12 series). The **A** wire shall connect to pin 3. The **B** wire shall connect to pin 4. The pins 1 and 6 should be connected to the circuit ground and these may be used for the shield of the interconnecting cable if it is provided. The usage of pins 2 and 5 is not standardized in this ETS, and they may be used for auxiliary proprietary signalling.

(See subclause C.2.1 for relation between the wiring and the synchronization signal polarity.)

##### C.1.2 External synchronization input port

The external synchronization input port shall conform to RS422 section 4.2 (see Annex E) and shall present a termination impedance of  $100 \Omega \pm 10 \%$ .

The external synchronization input port shall be marked "SYNC IN".

If connection terminals are used, one terminal shall be marked **A'** (corresponding to A' in RS422) and the other terminal shall be marked **B'** (corresponding to B' in RS422).

If a connector is used, it shall be a modular telephone jack with 6 contacts (such as RJ12 series). The **A'** wire shall connect to pin 3. The **B'** wire shall connect to pin 4. The pins 1 and 6 shall not be connected. The usage of pins 2 and 5 is not standardized in this ETS, and they may be used for auxiliary proprietary signalling.

(See subclause C.2.1 for relation between the wiring and the synchronization signal polarity.)

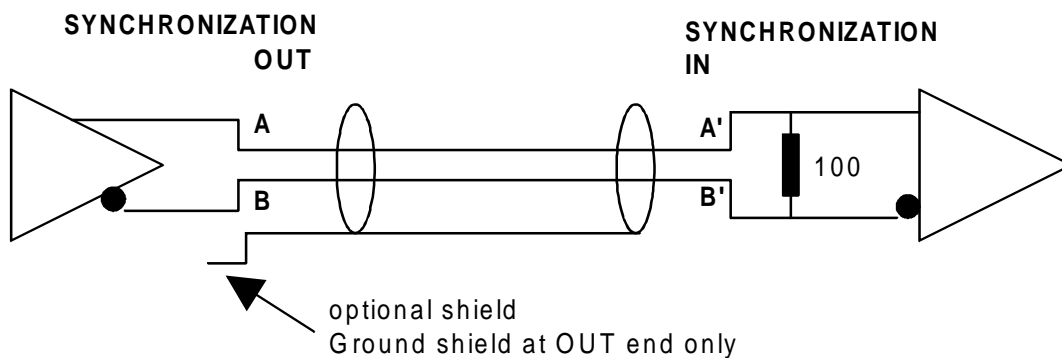

Figure C.1: Interconnection of synchronized devices

## C.2 Synchronization

The device to be synchronized shall monitor the external synchronization input port for a valid input synchronization signal. The device may consider any input signal not meeting the requirements of subclause C.2.1 (except polarity) as invalid. If an input synchronization signal is detected that has the incorrect polarity but otherwise meets the requirements of this annex, the device should maintain the correct synchronization (i.e. synchronize to positive pulse edges rather than negative) and its regenerated output signal shall have the correct polarity.

The detection or loss of an input synchronization signal should result in the minimum of disruption to established radio operations and to the synchronization signal provided to the output synchronization port.

NOTE: The valid signal threshold level is not necessarily equal to the sensitivity level of the receiver circuit.

If a valid synchronization signal is detected, the device shall regenerate that signal at its output synchronization port. The propagation delay in the regenerated signal, between the input and output synchronization ports shall not exceed 200 ns. The propagation delay shall be measured at the zero crossing points of the differential input and output signals. The regeneration circuit should incorporate input hysteresis (the difference between positive going and negative going input threshold voltages) of nominally 50 mV.

When no valid input synchronization signal is detected, the device may cease generation of its output synchronization signals. Alternatively, when no valid input synchronization signal is detected and if it is capable of doing so, the CCFP may generate its own synchronization signal at its output synchronization port meeting the requirements of subclause C.2.1.

The transition times of the synchronization signal at the output synchronization port, either generated or regenerated within the device, from the 10 % to 90 % points and from the 90 % to 10 % points shall not exceed 120 ns when measured into a  $100 \Omega \pm 10 \%$  load (see figure C.2).

The amplitude of the synchronization signal, either generated or regenerated within the device, or an externally generated synchronization signal, shall conform to the specifications of RS422 section 4.1 (see Annex E).

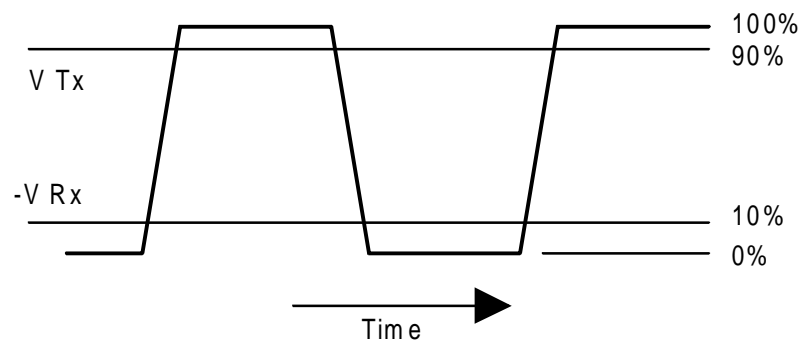

Figure C.2: Transition timing of synchronization signal

### C.2.1 External synchronization signal

The synchronization signal illustrated in figure 3 is a 100 Hz signal having positive pulses of width between  $5 \mu\text{s}$  and  $1 \text{ ms}$ , except for frame 0 (every 16th pulse), which has a pulse width between  $2 \text{ ms}$  and  $5 \text{ ms}$ . This signal establishes the  $10 \text{ ms}$  frame interval and the  $160 \text{ ms}$  "multiframe" interval. As the wave form is asymmetric devices can establish proper timing relations in the event that the differential pair of input signal wires is (improperly) connected (pair inversion).

The synchronization signal shall have a long term frequency accuracy of better than  $\pm 5 \text{ ppm}$  (nominal conditions) or  $\pm 10 \text{ ppm}$  (extreme conditions).

The synchronization signal shall be considered to be a positive signal (as illustrated in figure C.3) when the **A** terminal is positive with respect to the **B** terminal (see subclause C.1.1 and C.1.2).

The random phase jitter on the falling edge of the synchronization signal shall not exceed  $0,5 \mu\text{s rms}$ . The differential amplitude shall be greater than  $400 \text{ mV}$  peak to peak.

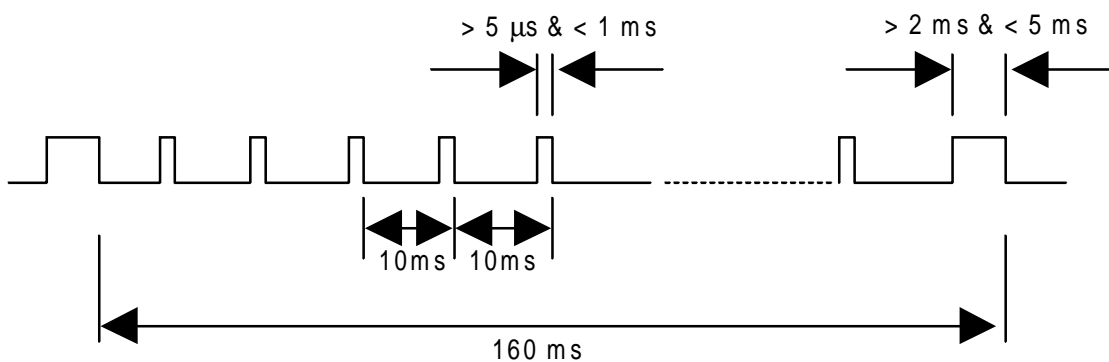

Figure C.3 Synchronization signal timing

In some specific cases, such as synchronization using a GPS time reference, it may be needed to use the signal described in figure 3 to identify the start of a hyperframe (25 multiframe). In such a case, every 25<sup>th</sup> multiframe pulse has a width between  $4 \text{ ms}$  and  $5 \text{ ms}$ . The falling edge of this pulse relates to the start of the hyperframe, which contains 25 multiframe. All the other multiframe pulses have a width between  $2 \text{ ms}$  and  $3 \text{ ms}$ . The distinction between hyperframes and multiframe is optional.

### C.2.2 Envelope synchronization

For any RFP,  $T_0$  is defined as the time when the start of bit p0 of a packet occurs or should occur at the antenna of this RFP, if being transmitted on slot  $K=0$ .

The rear falling edge of a transmitted synchronization pulse shall occur at the output port of the master FP  $15 \mu\text{s} \pm T_t \mu\text{s}$  before  $T_0$  of one RFP on the master FP.

$T_t = 5 \mu\text{s}$  for Class 1;

$T_t = 2 \mu\text{s}$  for Class 2.

$T_0$  of one of the RFPs on a slave FP shall occur  $T_d \mu\text{s}$  after the rear edge of synchronization pulses occurs at the input port of a slave FP.

$T_d$  is nominally  $15 \mu\text{s} \pm 5 \mu\text{s}$ .



### C.3 Interconnection cable

Where interconnecting cable is used to provide synchronization between systems or devices to be synchronized, it shall provide two independent signal paths, neither of which is grounded. The type and length of interconnecting cable used for synchronization shall ensure that during the transition period, the signal wave form (measured at the input synchronization port) shall change monotonically between the 10 % and 90 % points and shall not cross the 10 % and 90 % thresholds again until the next state transition point. The interconnection cable shall ensure that the input signal meets the requirements of subclause C.2.1.

If shielded cable is used for the interconnection of synchronized equipment, then only the end of the cable connected to the output synchronization port may be grounded.

### C.4 Propagation delay of synchronization signals

#### C.4.1 Calculation of Propagation delay (informative)

The purpose of this informative subclause is to show a derivation of the maximum synchronization signal propagation delay, and to illustrate the trade off between the number of devices which may be connected in a cluster and the total length of interconnecting cable.

Let the maximum propagation delay of the synchronization signal from the first device in a cluster to the final device be  $D_{\max}$ . The time  $D_{\max}$  is derived as follows:

$$D_{\max} = G - J - S - T$$

where  
G = guard time  
J = portable timing jitter  
S = synchronization accuracy  
T = ramp down time

The maximum number of regenerations,  $R_{\max}$ , with no cable delay is:

$$R_{\max} = D_{\max} / T_{\text{reg}}$$

Where  $T_{\text{reg}}$  = regeneration delay in a device  
(= 200 ns see subclause C.2)

The maximum cable length,  $L_{\max}$ , with no regenerations, is given by:

$$L_{\max} = c \times VF \times D_{\max}$$

where  
c = speed of light =  $3 \times 10^8$  metres per second  
VF = cable velocity factor = in the range 0.6 to 0.7

This calculation indicates the maximum total length of cable between two devices to be synchronized. The maximum practical length for an individual section of cable between two devices will also be restricted by transmission line effects (see subclause C.3).

Neither the maximum cable length nor the maximum number of regenerations derived above will be achievable in any practical system. There will always be a trade-off between the number of synchronized devices or systems (i.e. regenerations) and the length of cable needed to interconnect them.

**C.4.2 Delay compensation**

In order to compensate for installation dependent synchronization signal delays (e.g. as a result of cable propagation delays) between devices to be synchronized, it is recommended that it be possible for slave devices to be capable of adjusting  $T_d$  (see subclause C.2.2) between 0 and 20  $\mu$ s to a resolution of at least 2  $\mu$ s. Means of making this timing adjustment shall be provided by class 2 equipment.

**C.5 Synchronization by a GPS receiver.**

The signal transmitted by a Global Positioning System (GPS) satellite indicates the GPS time, which is related but not equal to the Universal Time Coordinated (UTC). The GPS time should be considered as the standard time of the GPS system. In contrast with the UTC, the GPS time is not subject to leaped seconds. The GPS time provides an absolute time reference. This makes the GPS receiver time suitable for multiframe synchronization of DECT systems. Also multiframe number synchronization and Primary receiver Scan Carrier Number (PSCN) synchronization is derivable. Network layer messages are available to provide information on the level of synchronisation provided between two FPs (ETS 300 175-5 [4], subclauses 7.7.20, 7.7.51).

DECT systems are synchronized by relating the start of the first frame of a multiframe to the GPS time. Since the time duration of a DECT multiframe is 160 ms, this implies that once every 4 seconds the start of a DECT multiframe coincides with an integer GPS second. For convenience, this is called a DECT hyperframe. The DECT hyperframe has a duration of 4 seconds and contains 25 DECT multiframes.

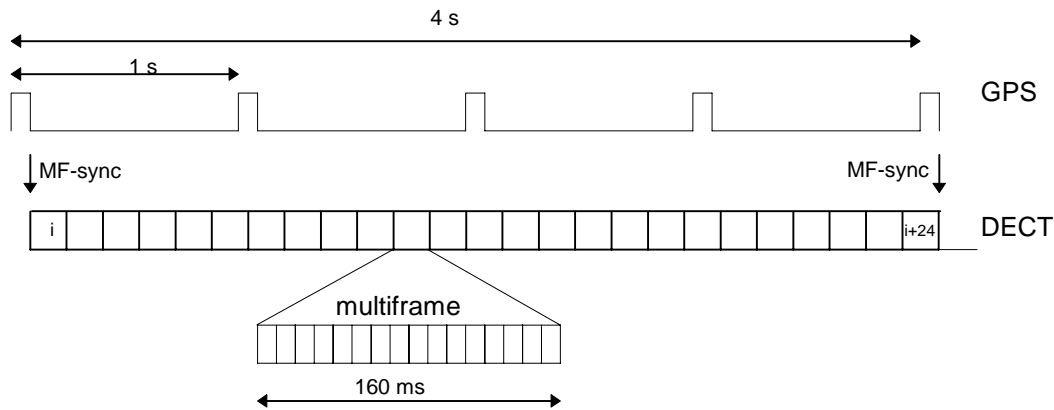

**Figure C.4. Relation between DECT and GPS timing**

**C.5.1 DECT multiframe time synchronization using GPS**

The start of a DECT multiframe shall be related to the GPS time as follows:

$$T_{GPS} \text{ mod } 4 = 0.$$

This marks the start of a DECT hyperframe.

A synchronization solution containing a GPS receiver shall furthermore meet the timing requirements for the DECT SYNC port stated in subclauses C.1 and C.12. The DECT SYNC port interface requirements are not relevant.

### C.5.2 DECT multiframe-number synchronization using GPS

Multiframe number synchronization can only be established between two adjacent systems if they also have multiframe time synchronization. The Multi Frame Number of the first multiframe of a DECT hyperframe (starting at  $T_{GPS} \bmod 4 = 0$ ) shall be related to the corresponding GPS time as follows:

$$MFN = \left( \frac{25}{4} T_{GPS} \right) \bmod 2^{24}$$

NOTE: The multiframe number consists of 24 bits in a MAC Q<sub>T</sub> message (ETS 300 175-3 [2], subclause 7.2.3.7).

### C.5.3 DECT PSCN synchronization using GPS

The PSCN message (ETS 300 175-3 [2], 7.2.3.2.12) defines the RF carrier on which one receiver will be listening on the next frame when only one receiver is idle.

NOTE: PSCN synchronization is only possible if two systems use the same set of RF carriers and if the systems are at least multiframe time synchronized.

Assuming that  $N_C$  carriers are being used by both systems, this implies that all  $N_C$  carriers are scanned within a sequence of  $N_C$  frames (one carrier per frame). Since a hyperframe contains 400 frames, the minimum number of hyperframes at which the PSCN sequence repeats itself is given by:

$$N_H = \frac{N_C}{\text{LCD}(N_C, 400)}$$

where the notation  $\text{LCD}(N_C, 400)$  denotes the Largest Common Denominator of  $N_C$  and 400.

When using GPS for synchronization of the PSCN, the PSCN of the first frame of the hyperframe starting at  $T_{GPS} \bmod (4 \cdot N_H) = 0$  shall be equal to the RF carrier number corresponding with the lowest carrier frequency used by the system. Currently only 10 carriers in the frequency band 1880 - 1900 MHz are applied so  $N_C=10$  and  $RF_L = 0$  (see ETS 300 175-3 [2], subclause 7.2.3.2.12).

EXAMPLE 1:  $N_C=10$ , Carrier no. 0 - 9. (current situation).

$N_H = 1$ ; In the first frame of each hyperframe at  $T_{GPS} \bmod 4 = 0$ , PSCN=0. It takes a maximum of 4 seconds before the PSCN can be synchronized.

EXAMPLE 2:  $N_C=13$ , Carrier no. 17-29 (fictitious future situation).

$N_H = 13$ ; In the the first frame of each hyperframe at  $T_{GPS} \bmod 52 = 0$ . It takes a maximum of 52 seconds before the PSCN can be synchronized.

## Annex D (normative): Prolonged preamble

Implementing this provision is optional.

Prolonged preamble transmissions are intended to be used in combination with a preamble switched antenna instant receiver selection diversity algorithm implemented at the receiving end. This algorithm implies that the receiver during a first part of the preamble makes a first link quality estimate using one antenna, and during a second part makes a second estimate using the other antenna, and then, for a third (the last) part of the preamble and the rest of the packet, selects the antenna which gave the highest quality estimate. This algorithm can provide a performance improvement corresponding to 10 dB increased link budget in a mobile or moving environment. Traditional means to provide this performance improvement requires two complete radio receivers. The prolonged preamble helps implementing low-cost and efficient means for the quality estimates needed in the algorithm.

NOTE 1: Normal procedures carried out during the preamble when this algorithm is implemented will thus be sliding slot detection, bit synchronization, two quality estimations and two antenna switchings.

NOTE 2: The  $M_T$  "Quality control" advance timing command message is intended to facilitate the implementation of the prolonged preamble option for distances beyond 1 km (see ETS 300 175-3 [2] subclause 7.2.5.5, command 0110).

### D.1 Bit pattern

The extension of the preamble is 16 bits, s-16 to s-1, and the bit pattern is a continuous advance extension of the bit patterns defined for the preamble in subclause 4.6, Synchronization field S.

RFP transmissions: 1010 1010 1010 1010  
                          s-16                          s-1

PP transmissions: 0101 0101 0101 0101  
                          s-16                          s-1

### D.2 The power-time template

Packets with prolonged preamble are subject to the definitions and requirements of subclauses 5.1 and 5.2 with the notation p0 generally changed to p-16.

### D.3 Procedures for implementing a prolonged preamble

The prolonged preamble option may be implemented on FT and/or PT transmissions.

For FTs, the implementation of this option is only allowed if indicated in the "Extended fixed part capabilities", "Synchronization field options" (see ETS 300 175-3 [2], subclause 7.2.3.5.2.2).

For PTs, the implementation of this option is only allowed if indicated by a  $M_T$  "Quality control" prolonged preamble information message. It should be transmitted from the PT as the first possible  $M_T$  message after bearer set up (see ETS 300 175-3 [2], subclause 7.2.5.5, command code 0111, and ETS 300 175-3 [2] subclause 10.5). The prolonged preamble field may be used starting with the first PT transmission on the bearer, but it shall not begin later than the first physical packet immediately after the transmission of the  $M_T$  "Quality control" prolonged preamble information message.

#### **D.4 Procedures for implementing a switched receiver antenna diversity algorithm relying on a prolonged preamble**

The receiving side may or may not have implemented switched receiver antenna diversity algorithm relying on a prolonged preamble. The antenna selected when implementing this algorithm may be used for the next transmission, and may thus at the FT (RFPs) override any "Antenna switch request (Q1=1)" from a PT.

If such a receiver diversity algorithm is available, it shall only be used if the receiving side knows that the transmitting side has a prolonged preamble. Thus such a PT shall understand the extended FP capabilities, Synchronization field options message. If such a FT does not know which preamble is transmitted from a PT, then for each connection, the FT receiving side shall suppose that there is a standard preamble.

## Annex E (informative): Bibliography

- CEPT Recommendation T/SGT SF2 (89) 6/0: "Draft Recommendation T/SF Services and Facilities of Digital European Cordless Telecommunications".
- ETR 043: "Radio Equipment and Systems (RES); Digital European Cordless Telecommunications (DECT) Common interface Services and facilities requirements specification".
- ETR 015: "Digital European Cordless Telecommunications Reference Document".
- ETR 042: "Radio Equipment and Systems (RES); Digital European Cordless Telecommunications (DECT); A guide to DECT features that influence the traffic capacity and the maintenance of high radio link transmission quality, including results of simulations".
- ETR 056: "Radio Equipment and Systems (RES); Digital European Cordless Telecommunications (DECT); System description document".
- International Non-Ionizing Radiation Committee of the International Radiation Protection Association (IRPA 1988): "Guide-lines on limits of exposure to radio frequency electromagnetic fields in the frequency range from 100 kHz to 300 GHz".
- M.A. Stuchly (1987): "Proposed revision of the Canadian recommendations on radio frequency-exposure protection" (Health Physics, Vol. 53, N° 6).
- EIA 422-A-78: "Electrical characteristics of balanced voltage digital interface circuits".

## History

Document history	
October 1992	First Edition
July 1995	Public Enquiry PE 88: 1995-07-24 to 1995-11-17
June 1996	Vote V 106: 1996-06-24 to 1996-08-30
September 1996	Second Edition